

Progress on REBCO studies at UNIGE

Carmine SENATORE, Romain BABOUCHE, Celia LUCAS, Marco BONURA, Damien ZURMUEHLE



Department of Quantum Matter Physics, University of Geneva, Switzerland
Department of Nuclear and Particle Physics, University of Geneva, Switzerland

Tatsunori OKADA, Yuji TSUCHIYA, Satoshi AWAJI



High Field Laboratory for Superconducting Materials, University of Tohoku, Japan

Gianluca VERNASSA, Bernardo BORDINI, Luca BOTTURA



CERN, Switzerland





Outline

- **Commercial REBCO coated conductors: present performance**
 - Main characteristics of the examined tapes
 - Transport I_c measurements and scaling relations
 - Results of the measurement campaign on the angular dependence of I_c
- **An update on the experiment to test the Electromechanical Delamination Strength**
- **Summary and conclusions**





Outline

- **Commercial REBCO coated conductors: present performance**
 - Main characteristics of the examined tapes
 - Transport I_c measurements and scaling relations
 - Results of the measurement campaign on the angular dependence of I_c
- An update on the experiment to test the Electromechanical Delamination Strength
- Summary and conclusions





What has been tested – Catalogue of the Tapes

	Width	REBCO Type	REBCO Thickness	Deposition Method	Pinning Type	Hastelloy Thickness	Cu Stabilizer	$I_c(77K,s.f.)$	
	4 mm	EuBCO	2.5 μm	IBAD/PLD	BHO columns (artificial)	50 μm	2 x 40 μm electroplated	420 A/cm	
							2 x 20 μm electroplated	380 A/cm	
	2 x 10 μm electroplated						▲ 650 A/cm 558 A/cm 515 A/cm		
	2 mm						2 x 20 μm electroplated	555 A/cm	
 	4 mm	YBCO	▲ 3.1 μm	IBAD/PLD	Y_2O_3 particles (native)	▲ 100 μm	2 x 20 μm electroplated	550 A/cm	
			2.7 μm				40 μm	2 x 5 μm electroplated	490 A/cm
			2.5 μm						420 A/cm
	3 mm	EuBCO	3 μm	IBAD/PLD	BHO columns (artificial)	▼ 30 μm		590 A/cm	
	4 mm		2 μm				50 μm	2 x 10 μm electroplated	428 A/cm 645 A/cm 632 A/cm
 SCS4050-HM <small>A Furukawa Company</small>	4 mm	YBCO	▼ 1.5 μm	IBAD/MOCVD	BZO columns (artificial)	50 μm	2 x 5 μm electroplated	▼ 148 A/cm	





What has been tested – Catalogue of the Tapes

	Width	REBCO Type	REBCO Thickness	Deposition Method	Pinning Type	Hastelloy Thickness	Cu Stabilizer	$I_c(77K,s.f.)$	
	4 mm	EuBCO	2.5 μm	IBAD/PLD	BHO columns (artificial)	50 μm	2 x 40 μm electroplated	420 A/cm	
							2 x 20 μm electroplated	380 A/cm	
	2 x 10 μm electroplated						▲ 650 A/cm 558 A/cm 515 A/cm		
2 mm	2 x 20 μm electroplated						555 A/cm		
 	4 mm	YBCO	▲ 3.1 μm	IBAD/PLD	Y ₂ O ₃ particles (native)	▲ 100 μm	2 x 20 μm electroplated	550 A/cm	
			2.7 μm				40 μm	2 x 5 μm electroplated	490 A/cm
			2.5 μm						420 A/cm
	3 mm	EuBCO	3 μm	IBAD/PLD	BHO columns (artificial)	▼ 30 μm		590 A/cm	
	4 mm		2 μm				50 μm	2 x 10 μm electroplated	428 A/cm 645 A/cm 632 A/cm
 SCS4050-HM	4 mm	YBCO	▼ 1.5 μm	IBAD/MOCVD	BZO columns (artificial)	50 μm	2 x 5 μm electroplated	▼ 148 A/cm	





What has been tested – Catalogue of the Tapes

	Width	REBCO Type	REBCO Thickness	Deposition Method	Pinning Type	Hastelloy Thickness	Cu Stabilizer	$I_c(77K,s.f.)$	
	4 mm	EuBCO	2.5 μm	IBAD/PLD	BHO columns (artificial)	50 μm	2 x 40 μm electroplated	420 A/cm	
							2 x 20 μm electroplated	380 A/cm	
	2 x 10 μm electroplated	▲ 650 A/cm 558 A/cm 515 A/cm							
2 mm	2 x 20 μm electroplated	555 A/cm							
 	4 mm	YBCO	▲ 3.1 μm		Y ₂ O ₃ particles (native)	▲ 100 μm	2 x 20 μm electroplated	550 A/cm	
			2.7 μm			40 μm	2 x 5 μm electroplated	490 A/cm	
			2.5 μm					420 A/cm	
	3 mm	EuBCO	3 μm		BHO columns (artificial)	▼ 30 μm	2 x 10 μm electroplated	590 A/cm	
	4 mm		2 μm					50 μm	428 A/cm 645 A/cm 632 A/cm
 SCS4050-HM	4 mm	YBCO	▼ 1.5 μm			IBAD/MOCVD	BZO columns (artificial)	50 μm	2 x 5 μm electroplated

What has been tested – Catalogue of the Tapes

	Width	REBCO Type	REBCO Thickness	Deposition Method	Pinning Type	Hastelloy Thickness	Cu Stabilizer	$I_c(77K,s.f.)$
	4 mm	EuBCO	2.5 μm	IBAD/PLD	BHO columns (artificial)	50 μm	2 x 40 μm electroplated	420 A/cm
	2 mm						2 x 20 μm electroplated	380 A/cm
							2 x 10 μm electroplated	▲ 650 A/cm 558 A/cm 515 A/cm
							2 x 20 μm electroplated	555 A/cm
 	4 mm	YBCO	▲ 3.1 μm	IBAD/PLD	Y_2O_3 particles (native)	▲ 100 μm	2 x 20 μm electroplated	550 A/cm
			2.7 μm			40 μm	2 x 5 μm electroplated	490 A/cm
			2.5 μm					420 A/cm
	3 mm	EuBCO	3 μm	IBAD/PLD	BHO columns (artificial)	▼ 30 μm	2 x 10 μm electroplated	590 A/cm
	4 mm		2 μm			50 μm		428 A/cm 645 A/cm 632 A/cm
 <small>A Furukawa Company</small> SCS4050-HM	4 mm	YBCO	▼ 1.5 μm	IBAD/MOCVD	BZO columns (artificial)	50 μm	2 x 5 μm electroplated	▼ 148 A/cm

What has been tested – Catalogue of the Tapes

	Width	REBCO Type	REBCO Thickness	Deposition Method	Pinning Type	Hastelloy Thickness	Cu Stabilizer	$I_c(77K,s.f.)$
	4 mm	EuBCO	2.5 μm	IBAD/PLD	BHO columns (artificial)	50 μm	2 x 40 μm electroplated	420 A/cm
							2 x 20 μm electroplated	380 A/cm
	2 x 10 μm electroplated						▲ 650 A/cm 558 A/cm 515 A/cm	
	2 mm						2 x 20 μm electroplated	555 A/cm
 	4 mm	YBCO	▲ 3.1 μm	IBAD/PLD	Y_2O_3 particles (native)	▲ 100 μm	2 x 20 μm electroplated	550 A/cm
			2.7 μm			40 μm	2 x 5 μm electroplated	490 A/cm
			2.5 μm					420 A/cm
	3 mm	EuBCO	3 μm	IBAD/PLD	BHO columns (artificial)	▼ 30 μm	2 x 10 μm electroplated	590 A/cm
	4 mm		2 μm			50 μm		428 A/cm
								645 A/cm 632 A/cm
 SCS4050-HM	4 mm	YBCO	▼ 1.5 μm	IBAD/MOCVD	BZO columns (artificial)	50 μm	2 x 5 μm electroplated	▼ 148 A/cm

Comparison of the performance: I_c / width

The best performing tapes from each manufacturer



$T = 4.2 \text{ K}$

$T = 20 \text{ K}$

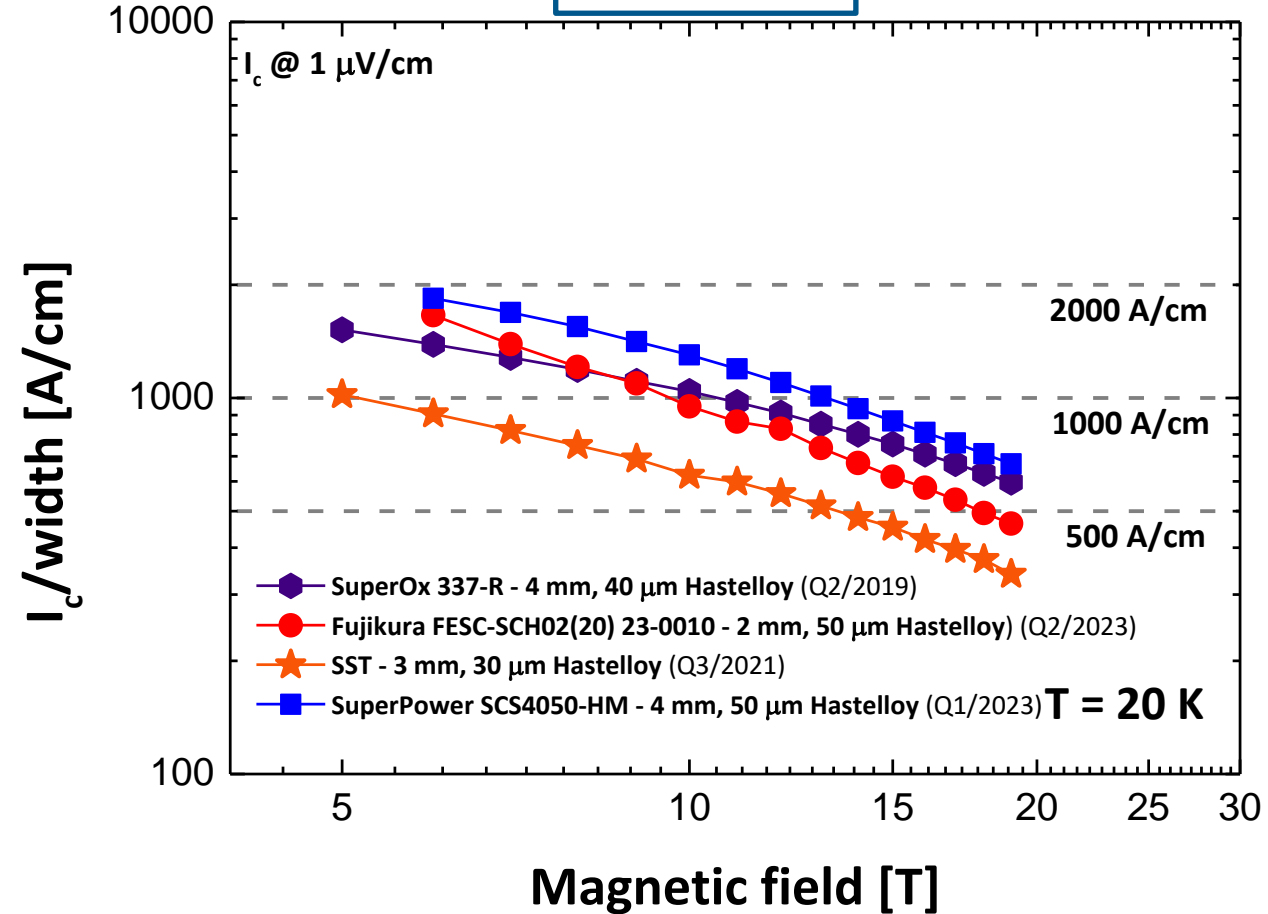
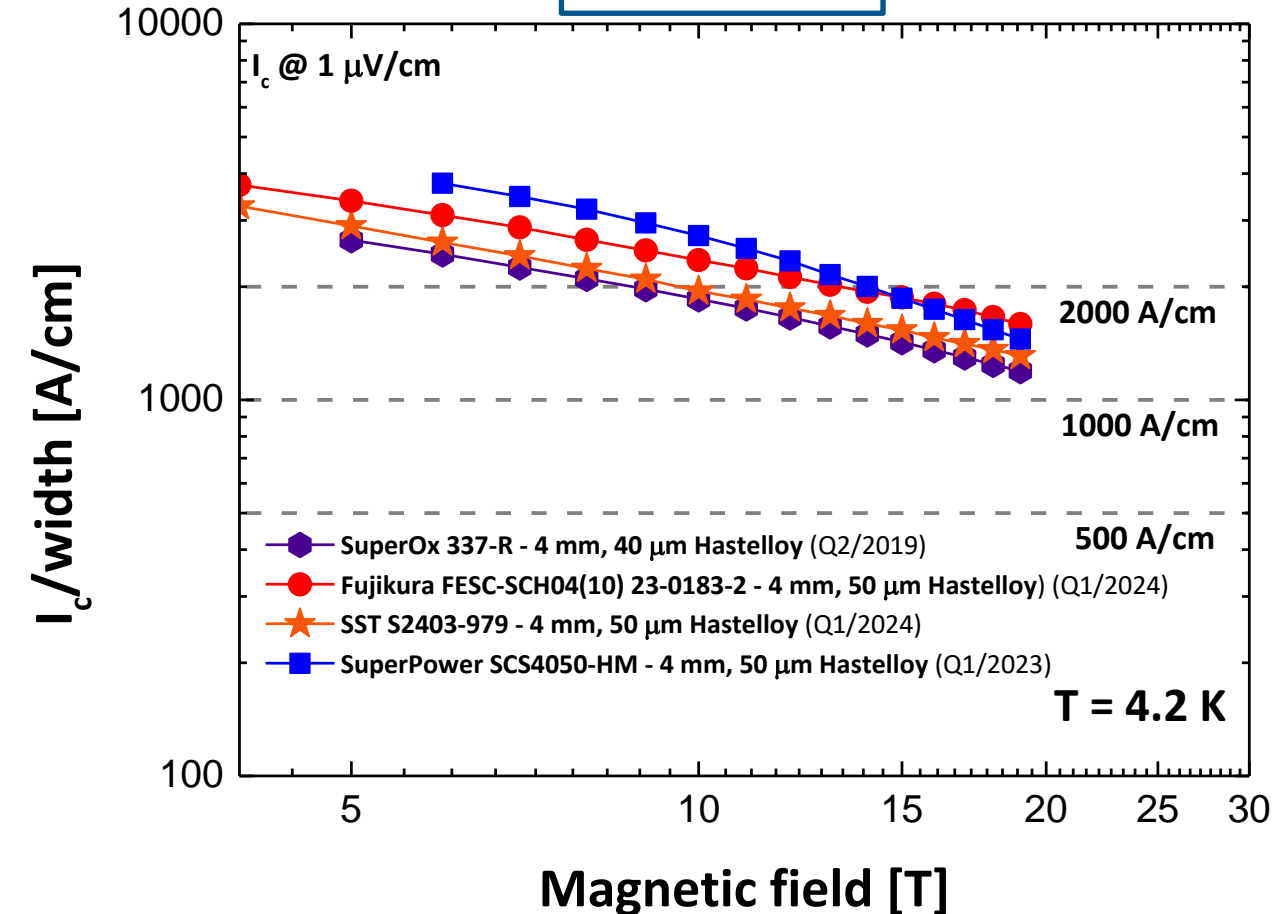

The highest I_c at 4.2 K, 19 T is reached with the tapes having the highest and the lowest I_c (77 K, s.f.)

Comparison of the performance: I_c / width

Batch-to-batch variability

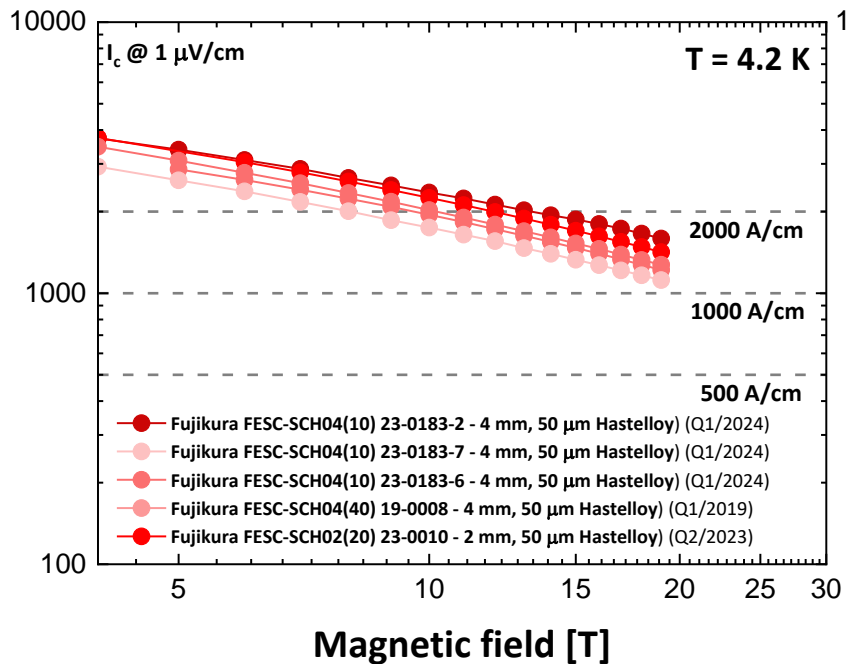

$$I_c(4.2 \text{ K}, 19 \text{ T})_{\text{LOW}} = 1100 \text{ A/cm}$$

$$I_c(4.2 \text{ K}, 19 \text{ T})_{\text{HIGH}} = 1600 \text{ A/cm}$$

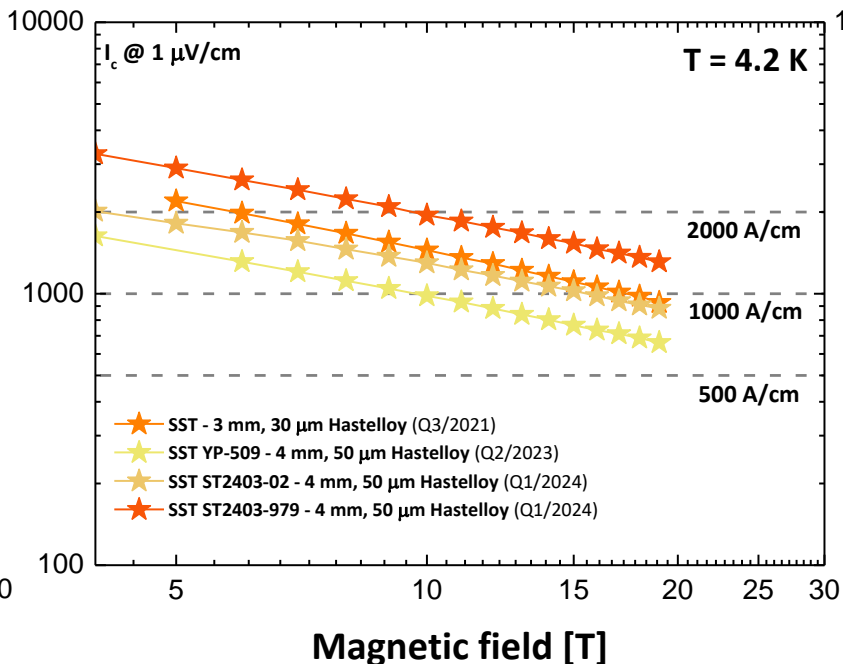

$$I_c(4.2 \text{ K}, 19 \text{ T})_{\text{LOW}} = 660 \text{ A/cm}$$

$$I_c(4.2 \text{ K}, 19 \text{ T})_{\text{HIGH}} = 1310 \text{ A/cm}$$

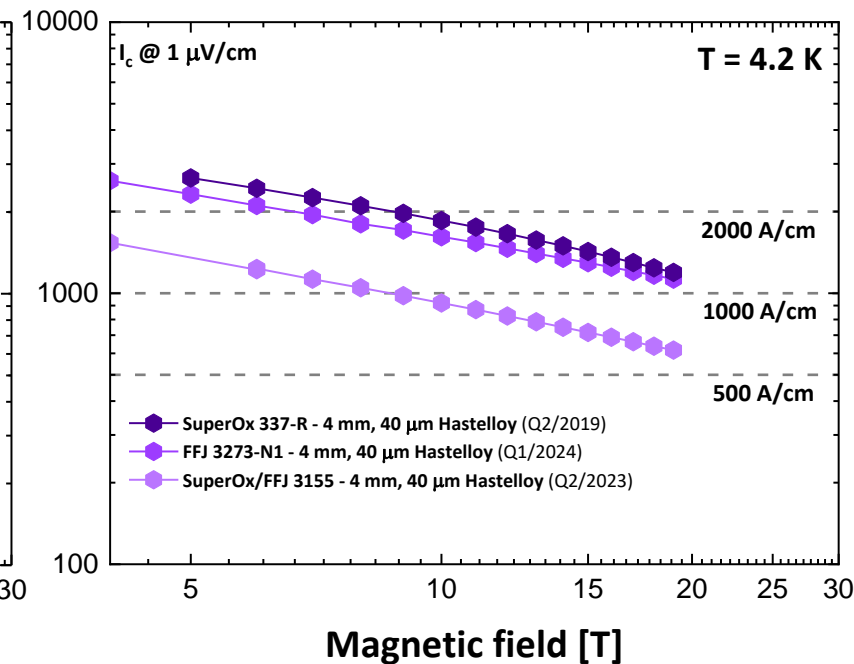

$$I_c(4.2 \text{ K}, 19 \text{ T})_{\text{LOW}} = 620 \text{ A/cm}$$

$$I_c(4.2 \text{ K}, 19 \text{ T})_{\text{HIGH}} = 1200 \text{ A/cm}$$

Scaling of the pinning force: $f_p \propto b^p(1-b)^q$

Normalized pinning force vs B / B_{peak} from magnetic and transport measurements



Fujikura

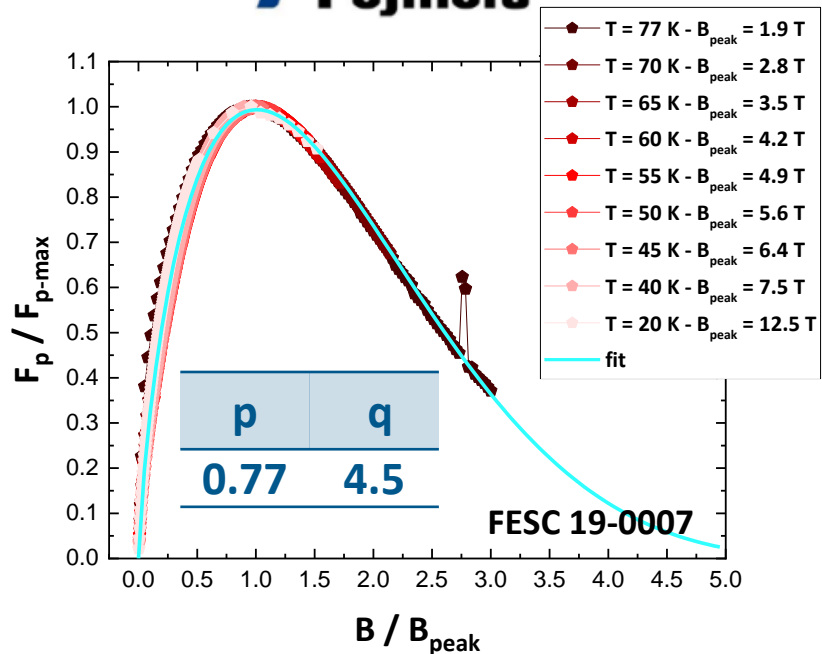

Pinning: Artificial - BHO columns

上海超导™
SHANGHAI SUPERCONDUCTOR

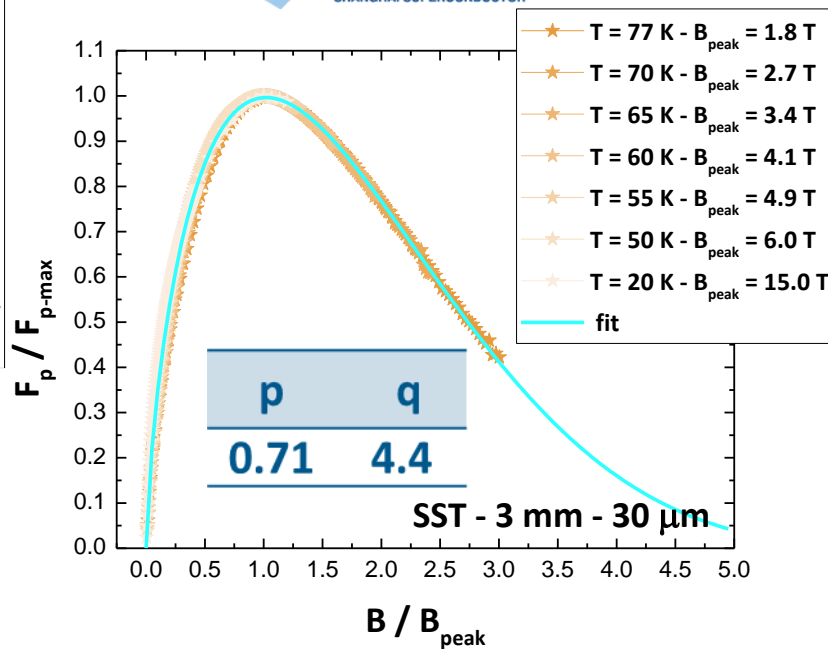

Pinning: Artificial - BHO columns

SuperOx JAPAN FARADAY FACTORY

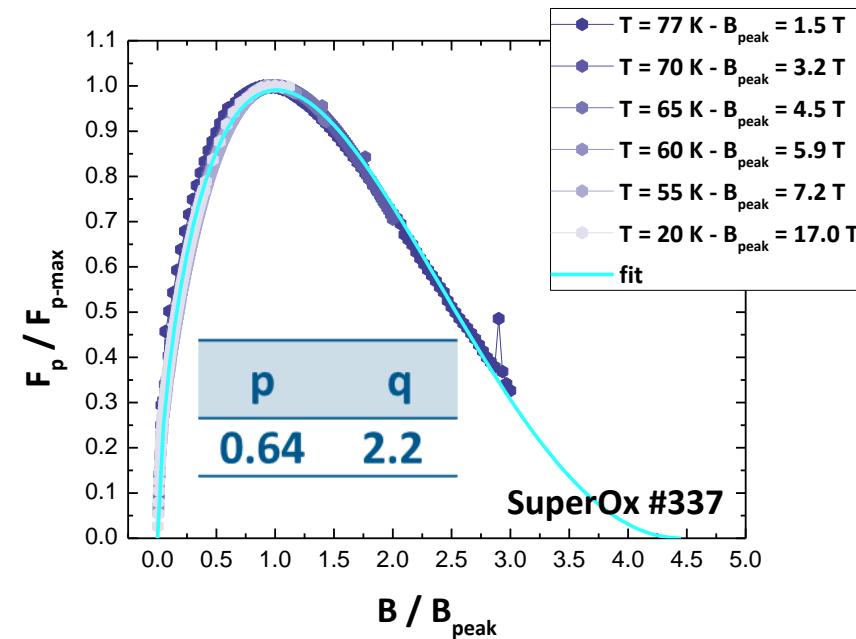

Pinning: Native - Y_2O_3 particles

Scaling of the pinning force: $f_p \propto b^p(1-b)^q$

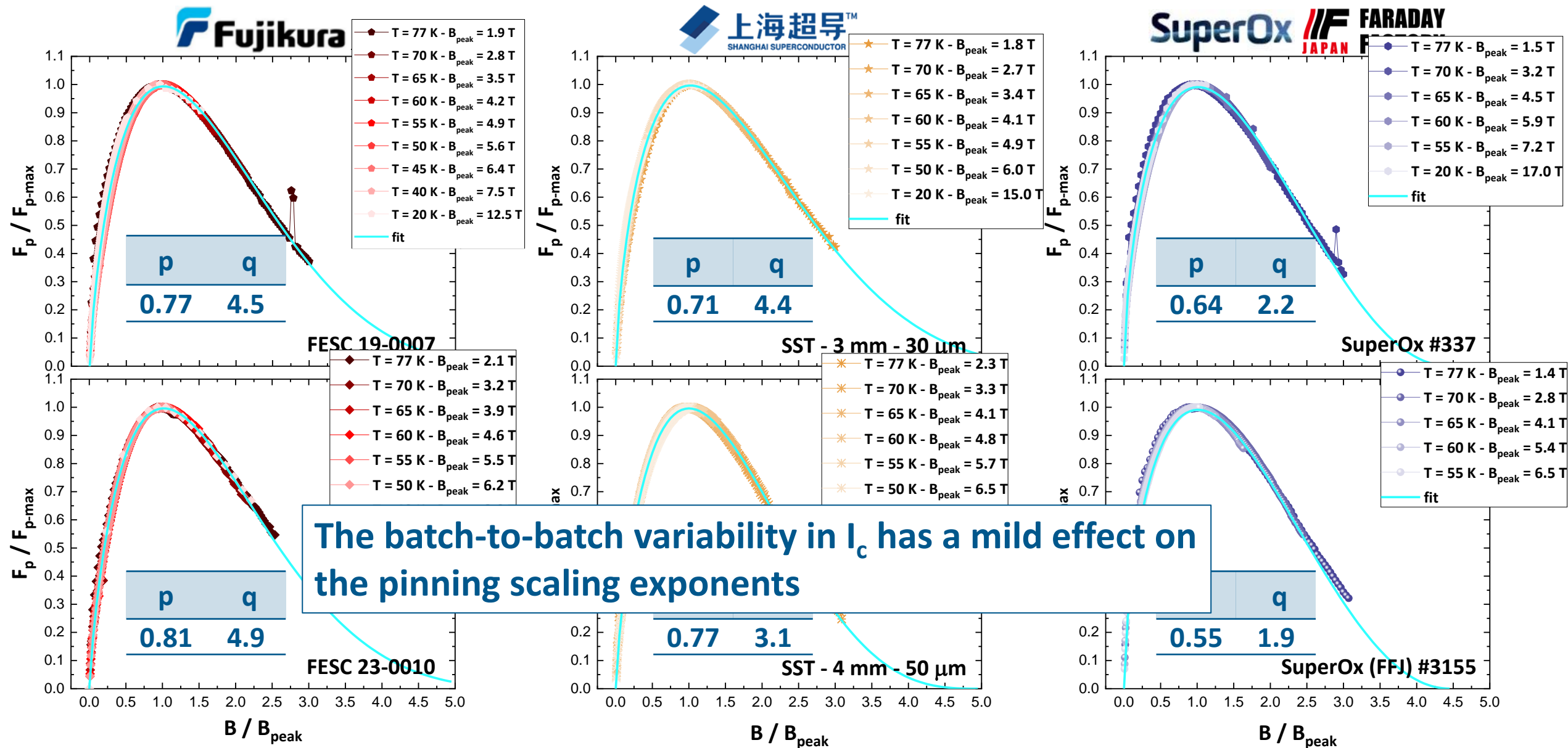

There is a robust scaling behavior in perpendicular field ...

... but REBCO anisotropy adds a layer of complexity

Measurement campaign on the angular dependence of I_c

Results on full-width tapes and microbridges

Setup at  UNIVERSITÉ DE GENÈVE
FACULTÉ DES SCIENCES

Experiments in Sendai at  TOHOKU UNIVERSITY



TOHOKU UNIVERSITY

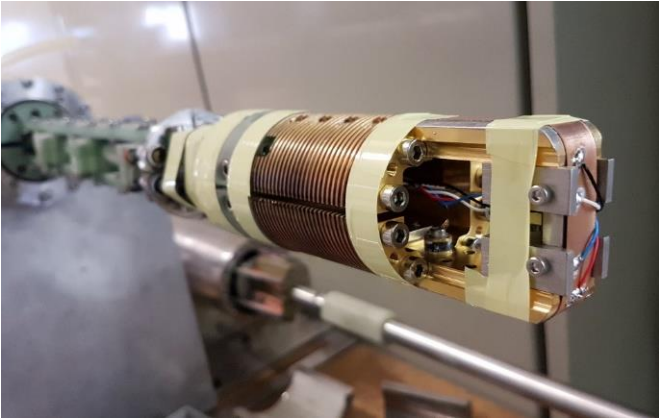

max current	2400 A
T range	4.2 – 40 K
B range	0 – 19 T (21 T)
Sample length	150 mm
Sample width	2 – 12 mm

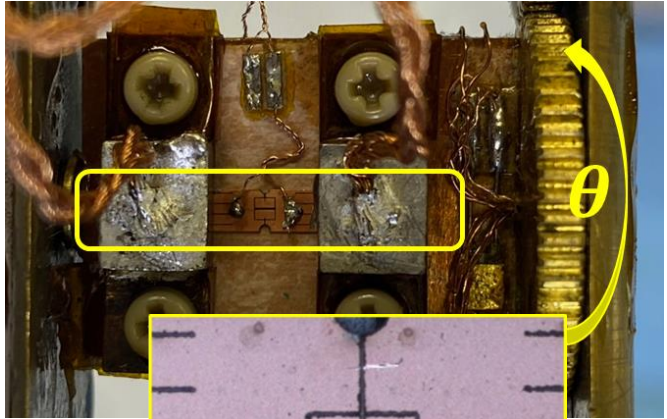

max current	20 A
T range	5 – 77 K
B range	0 – 24 T (15 T)
Bridge length	1 mm
Bridge width	30 μm

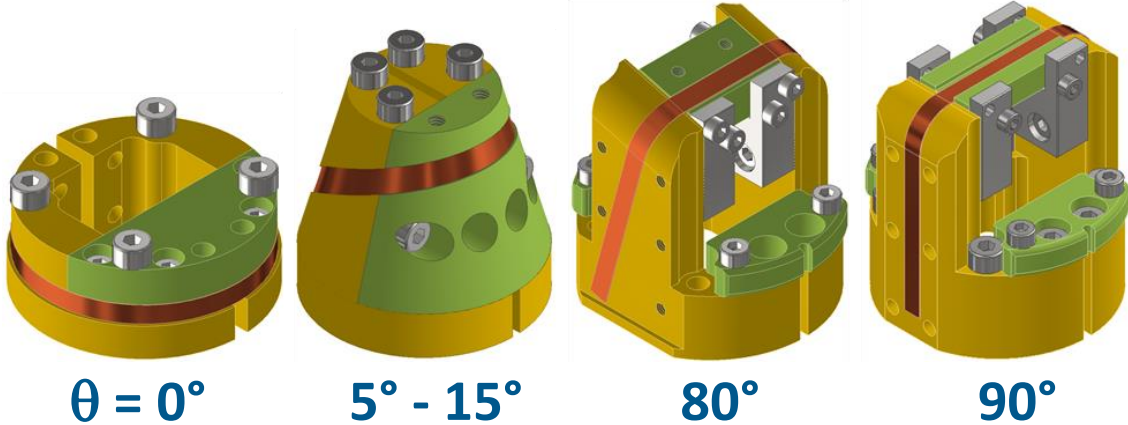

$\theta = 0^\circ$ $5^\circ - 15^\circ$ 80° 90°
Adapters with fixed orientation
A fresh sample is tested at each angle

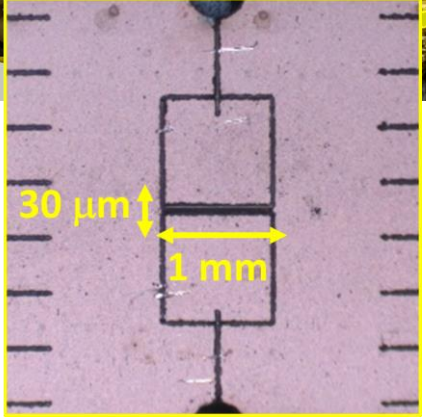

Continuous rotation between -20° and 115°
Microbridges patterned by laser machining

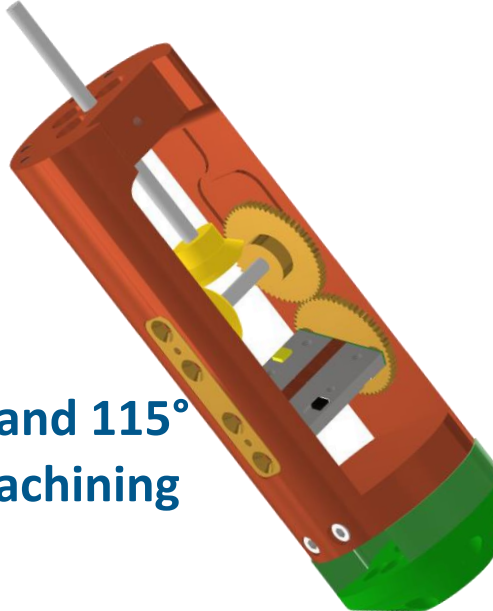

Measurement campaign on the angular dependence of I_c

Comparison of the results:



vs



UNIVERSITÉ
DE GENÈVE

FACULTÉ DES SCIENCES



TOHOKU
UNIVERSITY

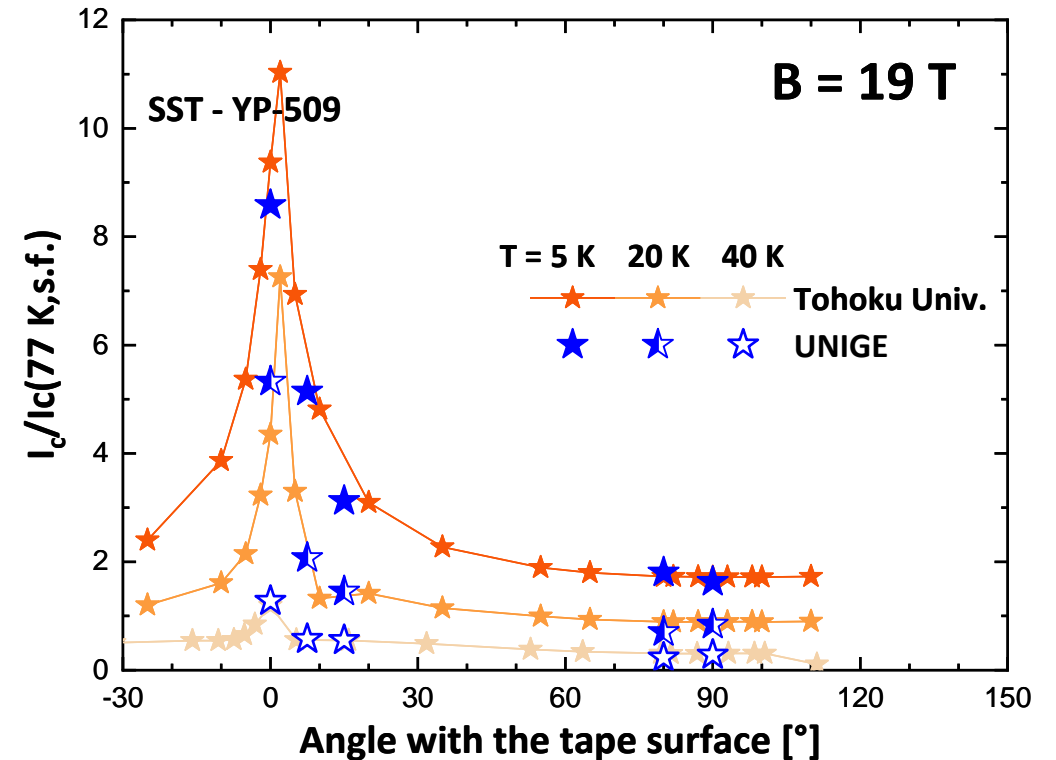
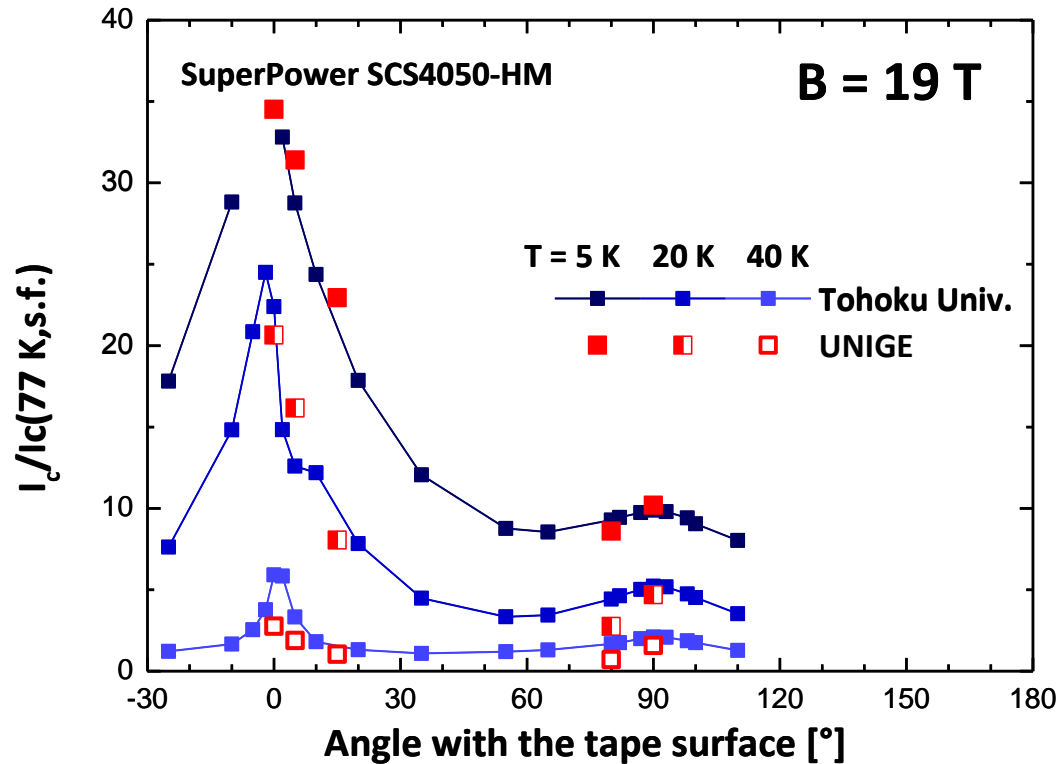

Good match of the results when comparing $I_c/I_c(77\text{ K, s.f.})$

In both experiments $I_c(77\text{ K, s.f.})$ is measured on the actual sample mounted on the probe

$I_c(B, \theta, T)$ does not exhibit universal behaviour

Comparison of the results on tapes from three manufacturers

SuperPower
Inc.
A Furukawa Company

上海超导™
SHANGHAI SUPERCONDUCTOR

SuperOx **IF** FARADAY
JAPAN FACTORY

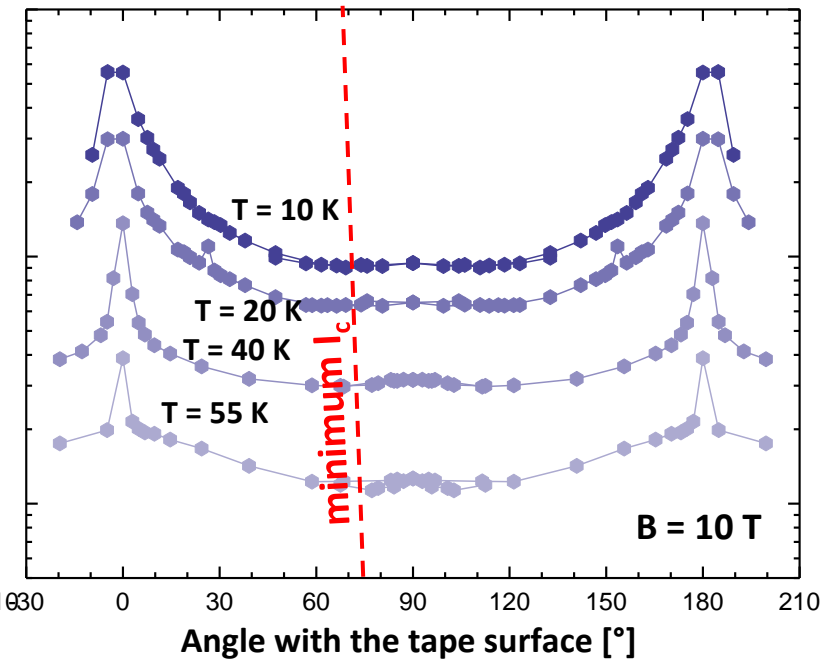
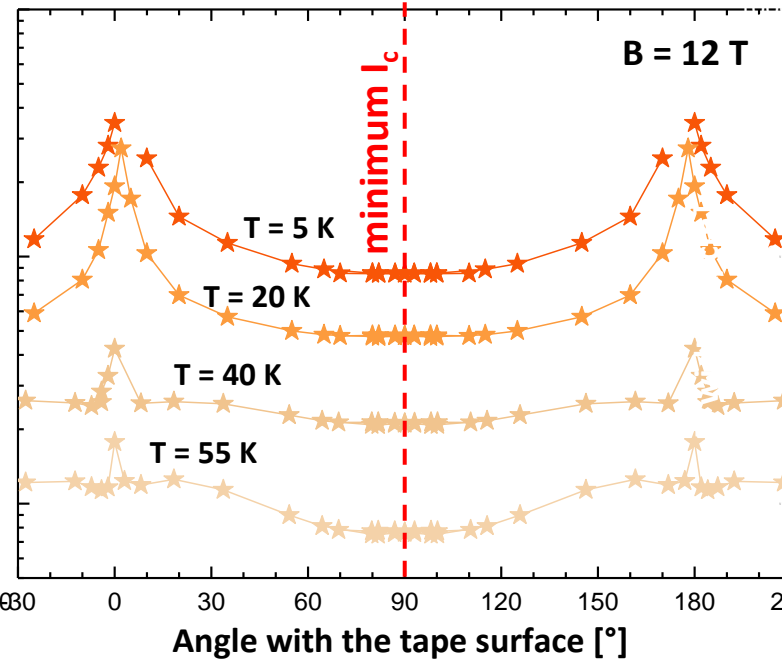
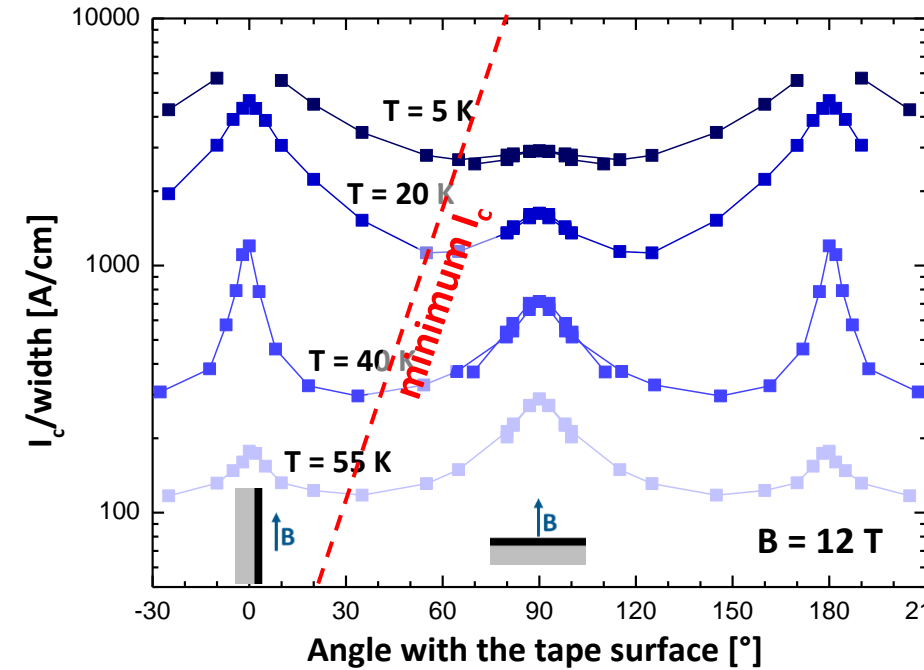

Outline

- **Commercial REBCO coated conductors: present performance**
 - Main characteristics of the examined tapes
 - Transport I_c measurements and scaling relations
 - Results of the measurement campaign on the angular dependence of I_c
- **An update on the experiment to test the Electromechanical Delamination Strength**
- Summary and conclusions

A short note on the mechanical properties

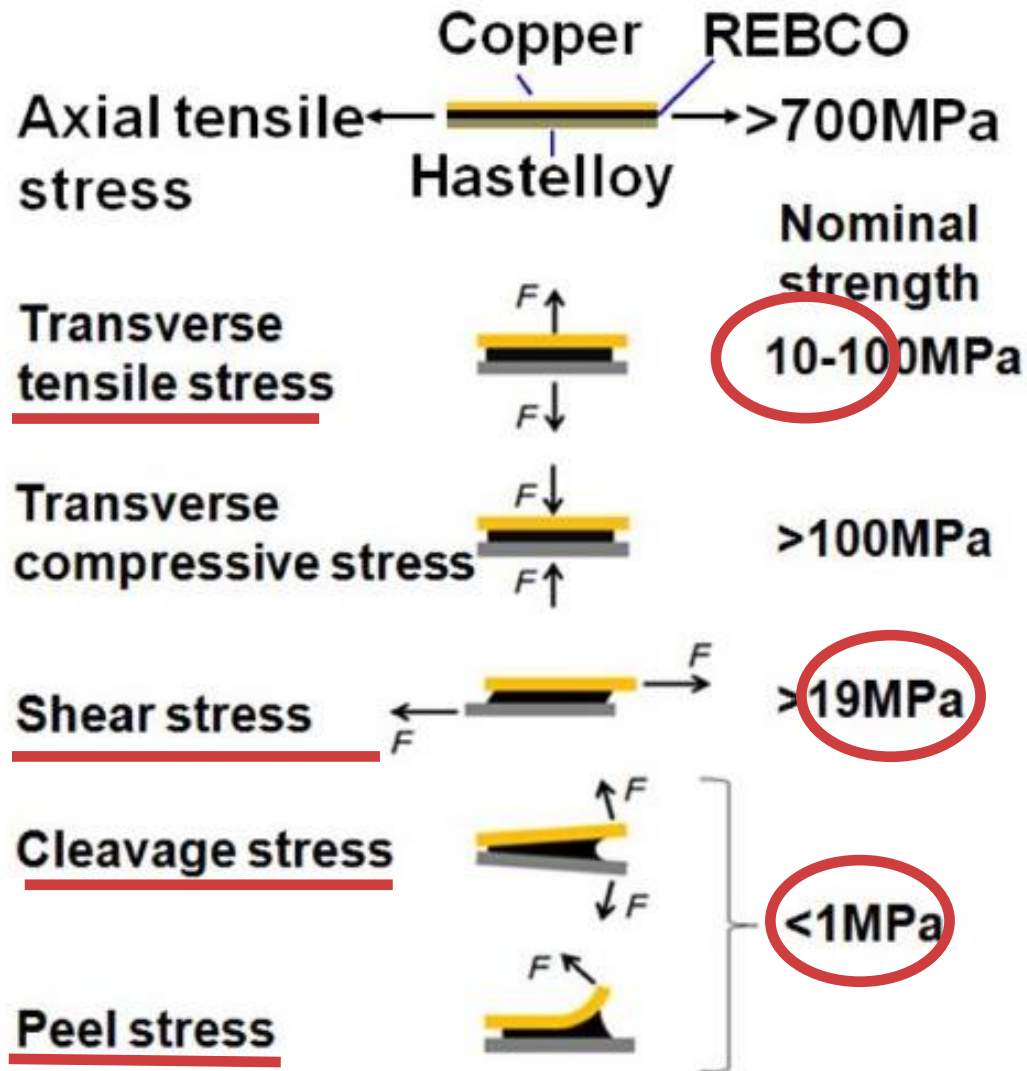

- REBCO tapes are inherently prone to delamination
- Adhesion between layers seems to be process dependent
- A standardized process to determine the properties of the tapes is missing

Electromechanical Delamination Strength measurement

A direct measurement of conductor degradation under I x B force

REBCO layer on the outside

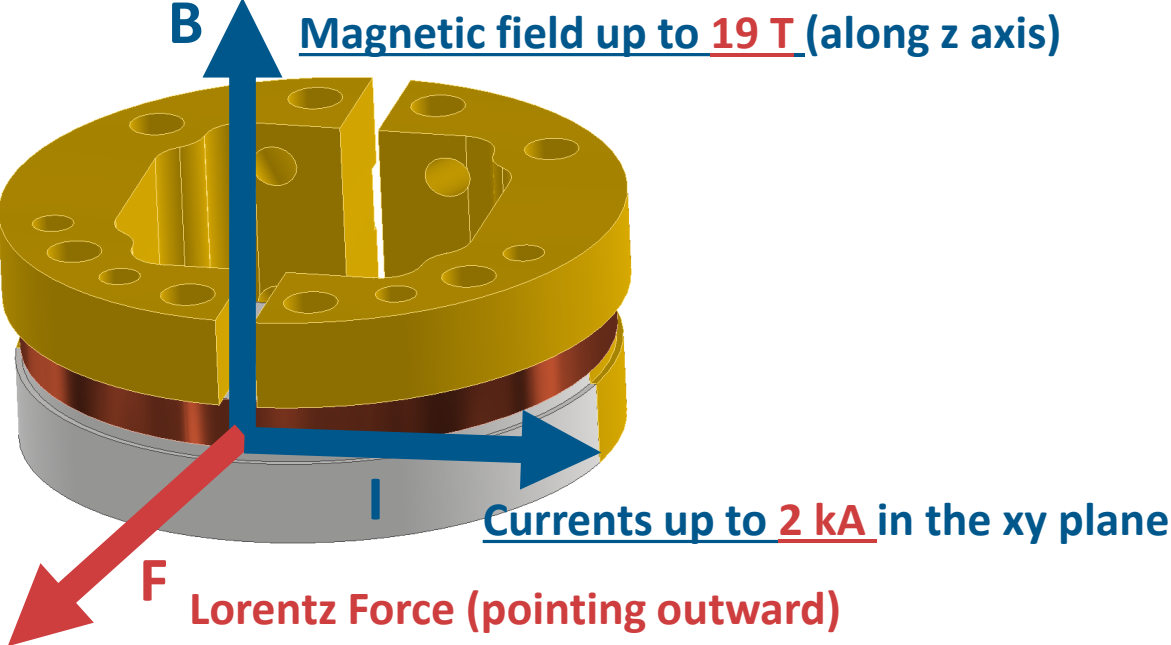

The average delamination stress is $\bar{\sigma}_T = \frac{F_R}{S} = \frac{I B}{w}$

Simulations from Gianluca Vernassa, CERN

Tape soldered only at the current injection

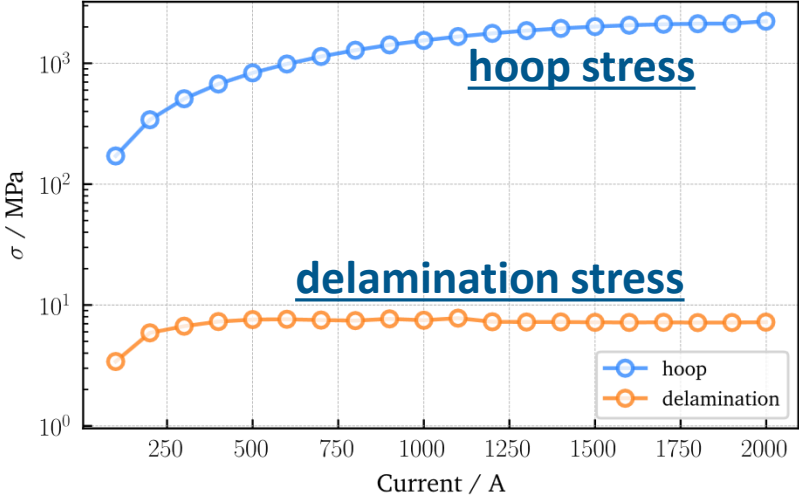

Tape soldered on the entire length

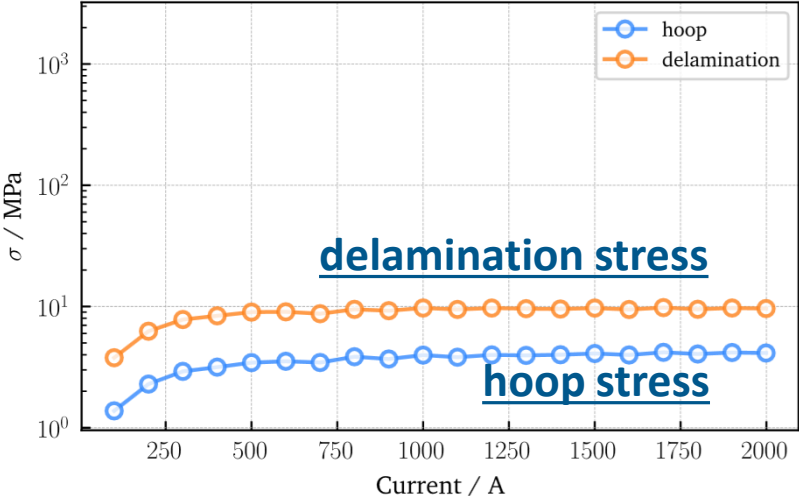

Electromechanical Delamination Strength measurement

A direct measurement of conductor degradation under $I \times B$ force

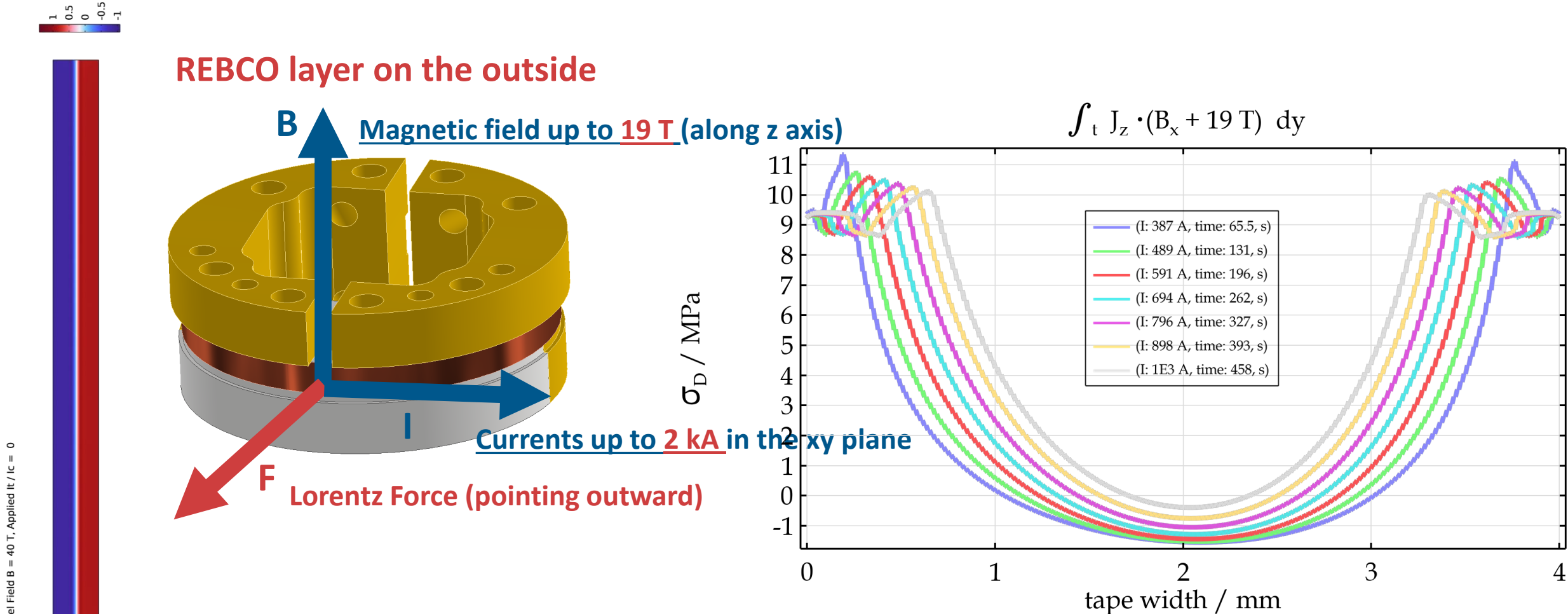

Evolution of the stress profile within the REBCO layer when current increases

Electromechanical Delamination Strength measurement

A direct measurement of conductor degradation under $I \times B$ force

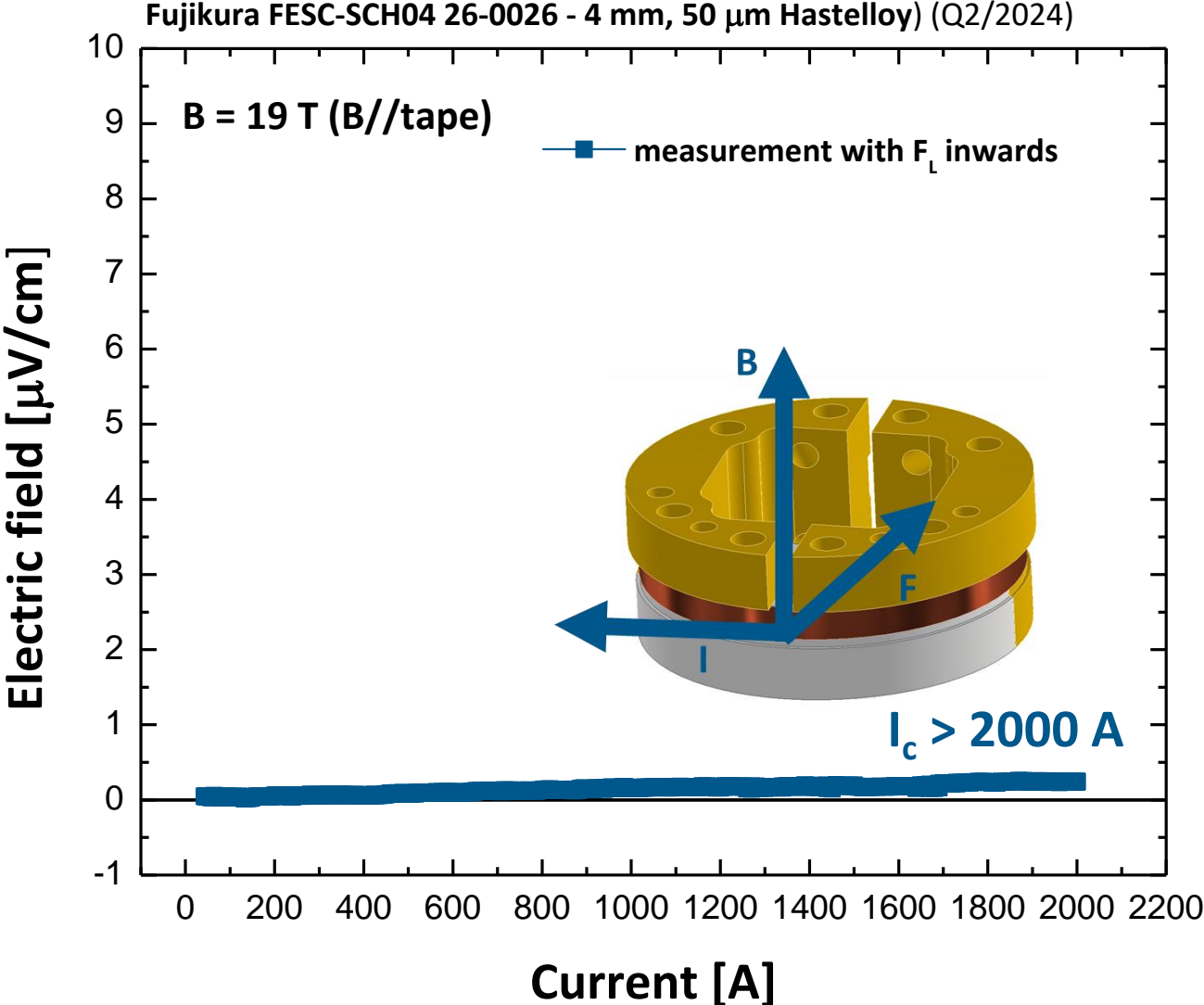

Electromechanical Delamination Strength measurement

A direct measurement of conductor degradation under $I \times B$ force

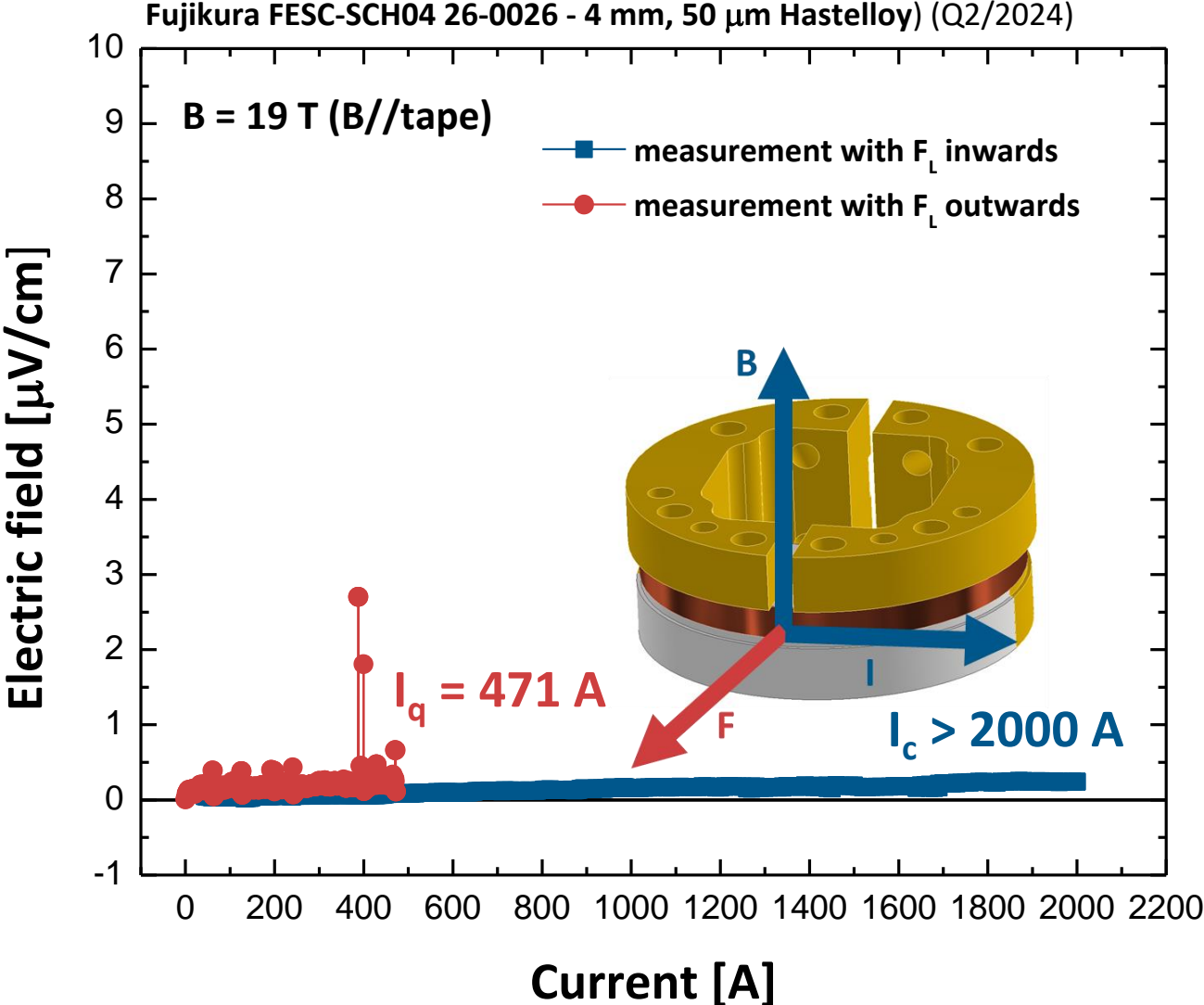

Electromechanical Delamination Strength measurement

A direct measurement of conductor degradation under $I \times B$ force

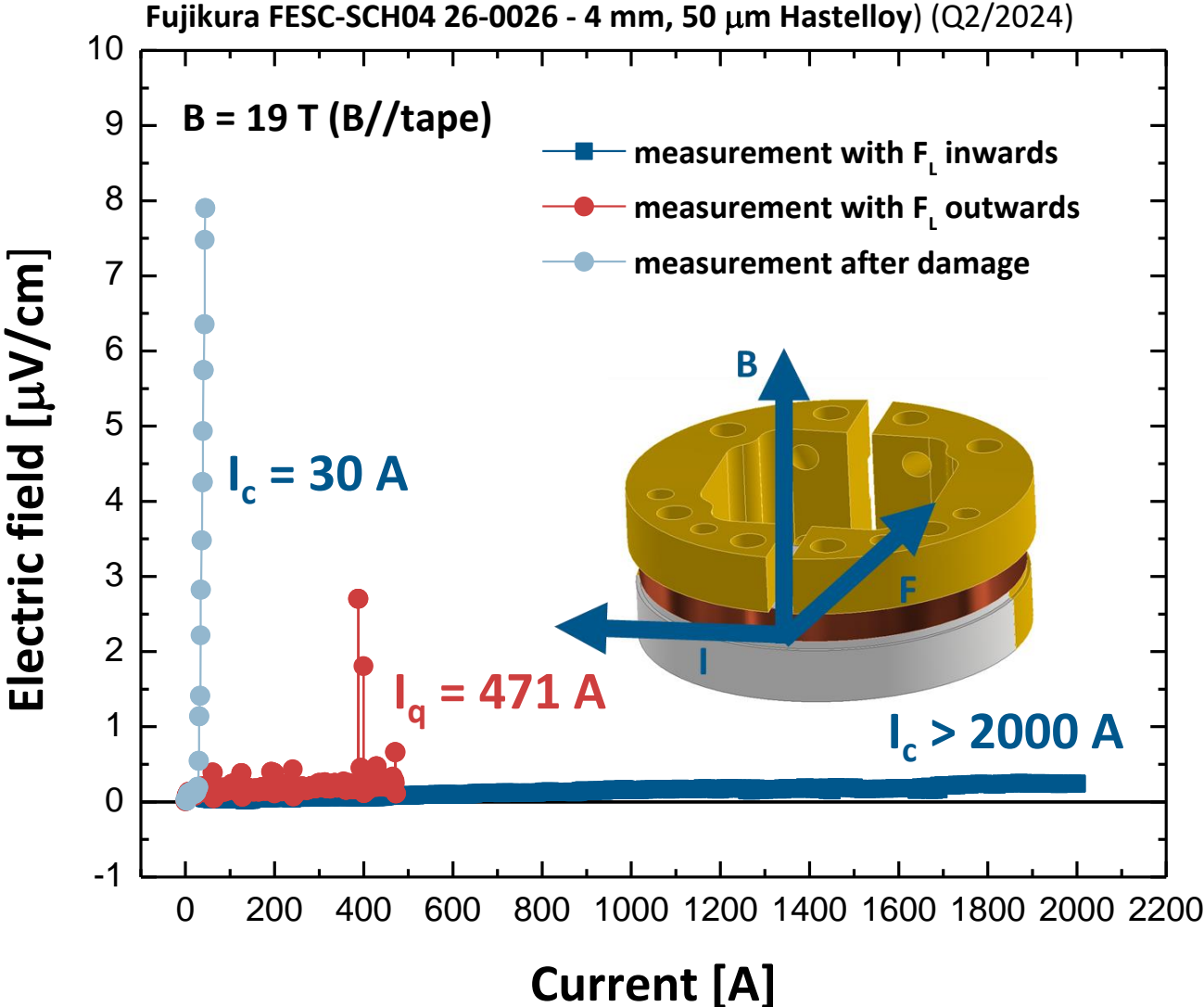

Electromechanical Delamination Strength measurement

Forensic studies

$J_c(77K)$ map of the sample before delamination experiment

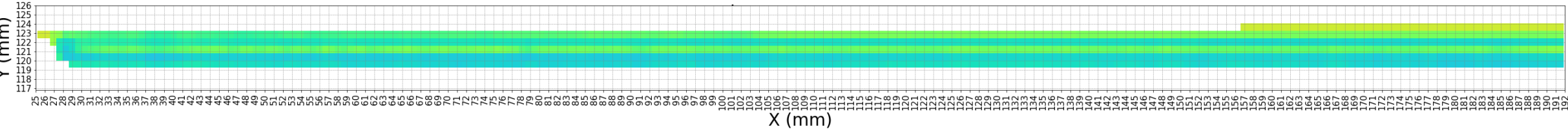

$J_c(77K)$ map after delamination

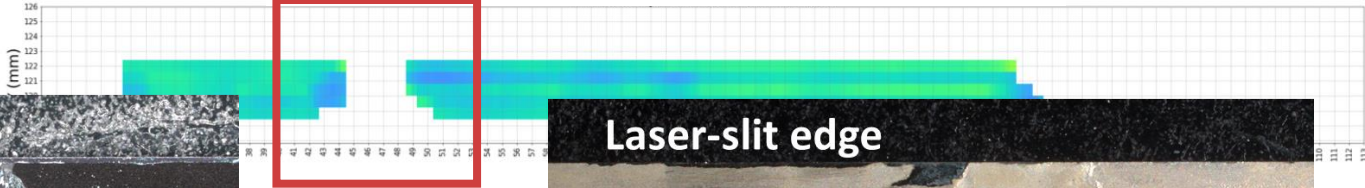

after Silver etching

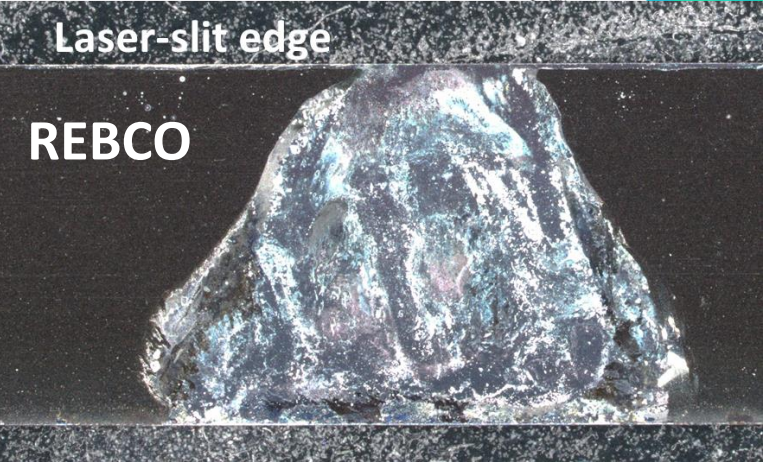

after Cu etching

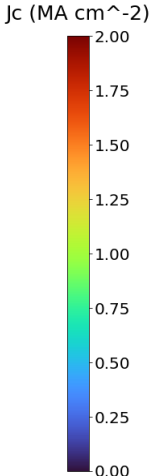

Electromechanical Delamination Strength measurement

Forensic studies

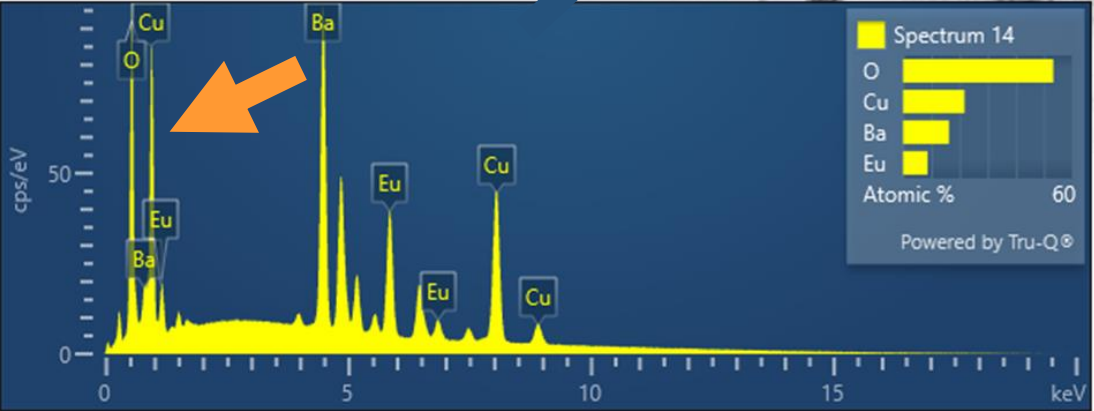
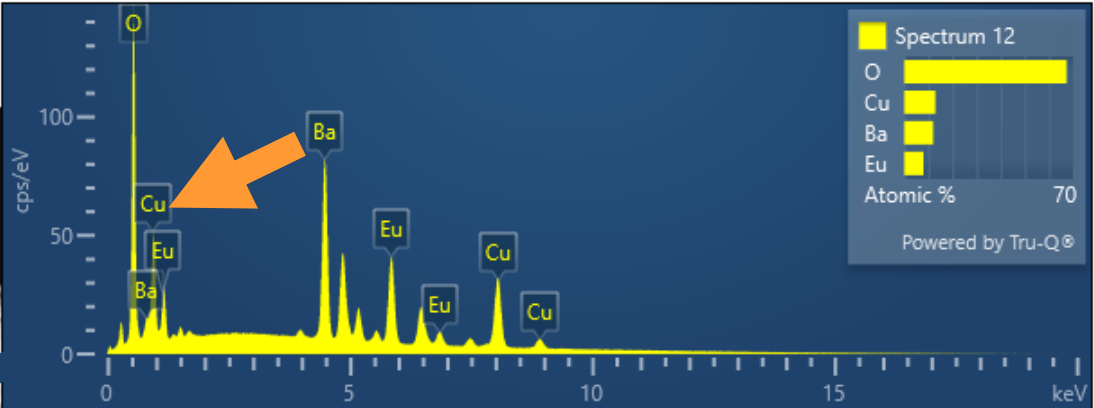
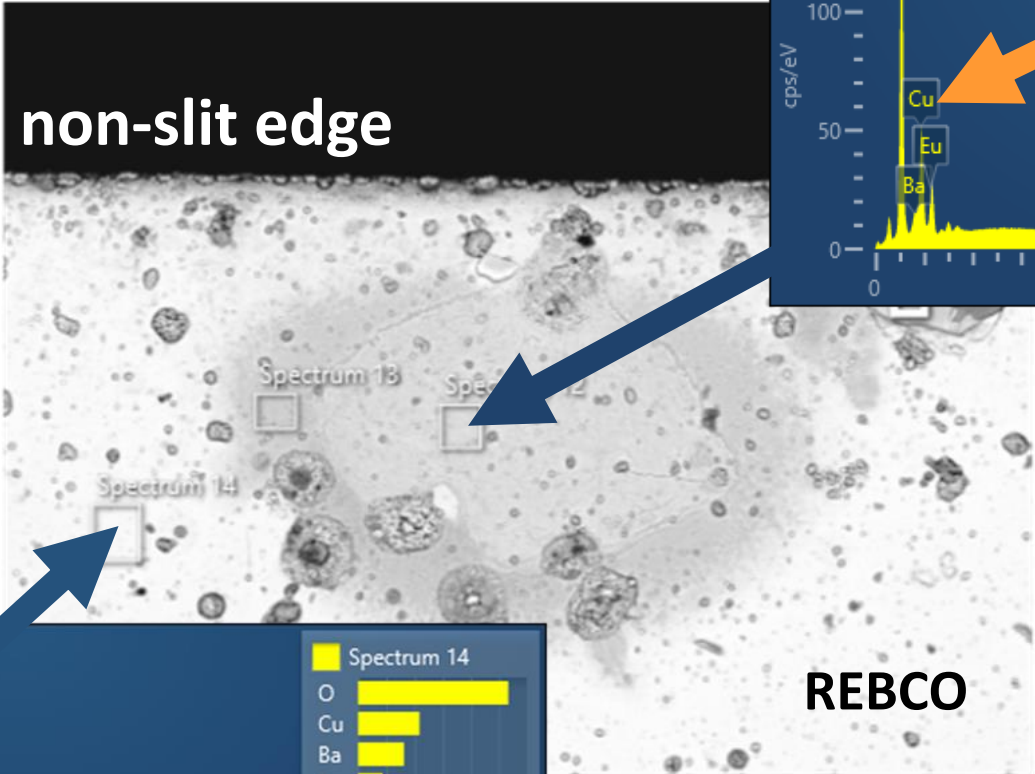

Summary and outlook

- The I_c values at low temperature/high field of commercial REBCO tapes in perpendicular orientation are quite close. And pinning forces scale reasonably well over a wide range of temperatures.
- Things change when we examine the angular dependence of I_c . It is strongly influenced by process, composition and pinning landscape.
- A complementary approach that combines a limited number of experiments on full-width tapes with detailed angular scans of microbridges would be an effective method for obtaining a high-fidelity description of the critical surface.
- The experiment to measure Electromechanical Delamination Strength has evolved thanks to insights from FEM studies. The results of the transport measurements are correlated with visual and compositional analyses (including optical and SEM imaging) as well as magnetic mapping.
- The procedure for EDS tests is being consolidated and will become a routine characterization method for tapes from all manufacturers.

Thank you for the attention !

Carmin SENATORE
carmine.senatore@unige.ch
<http://supra.unige.ch>

Acknowledgments: Financial support was provided by the State Secretariat for Education, Research and Innovation (SERI) for the Swiss participation to the Horizon Europe project MuCol.