

Direct calculation of Partonic Functions in Minkowski space

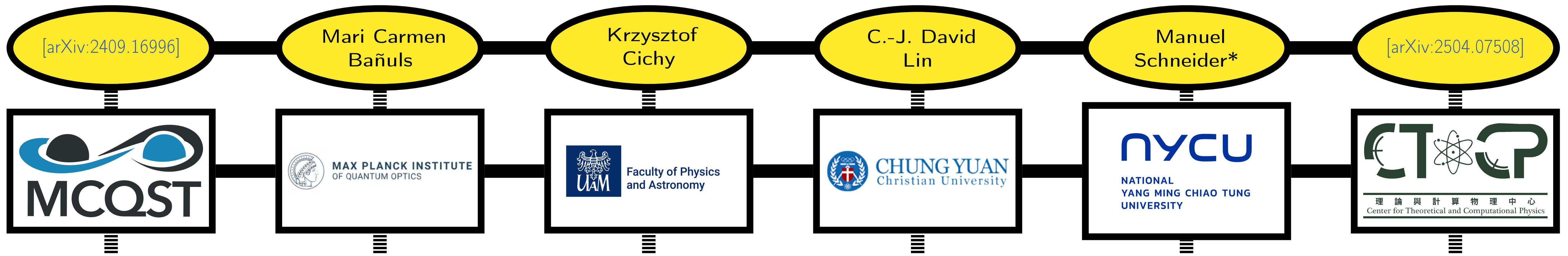

Abstract

Universal properties about the inner structure of hadrons can be described by parton distribution functions (PDFs) and lightcone distribution amplitudes (LCDAs). Their calculation involves the evaluation of matrix elements with a Wilson line in a light-cone direction. In contrast to Monte Carlo methods in Euclidean spacetime, these matrix elements can be directly obtained in Minkowski space using the Hamiltonian formalism. The necessary spatial- and time-evolution can be efficiently applied using tensor network methods. We calculate PDFs and LCDAs in the Schwinger model with matrix product states.

Hadron structure and partonic functions

- inner structure of hadrons can be tested by deep inelastic scattering (DIS): scattering of electron on a hadron
- exchanged photon has large momentum $Q^2 = -q^2$
- QCD is asymptotically free: photon scatters on free constituent (parton)
- scattering amplitude factorizes: perturbative part \times PDF
- PDF: probability of finding a parton with momentum fraction ξ
- fermion PDF of a hadron $|P\rangle$ with momentum P :

$$f_{\psi}(\xi) = \int \frac{dz^-}{4\pi} e^{-i\xi P^+ z^-} \langle P | \bar{\psi}(z^-) \gamma^+ W(z^- \leftarrow 0) \psi(0) | P \rangle$$

- momentum distribution of partons in decays/hadronization \rightarrow lightcone distribution amplitude (LCDA):

$$\phi(u) = \frac{1}{if} \int \frac{dz^-}{4\pi} e^{iuP^+ z^-} \langle 0 | \bar{\psi}(z^-) \gamma^+ \gamma_5 W(z^- \leftarrow 0) \psi(0) | P \rangle$$

- large $Q^2 \rightarrow$ light cone physics \rightarrow integration along light-front coordinate z^-
- lattice QCD in euclidean space: light cone \sim point \Rightarrow no access to z^-
- Hamiltonian formalism: light cone well-defined in Minkowski space \checkmark

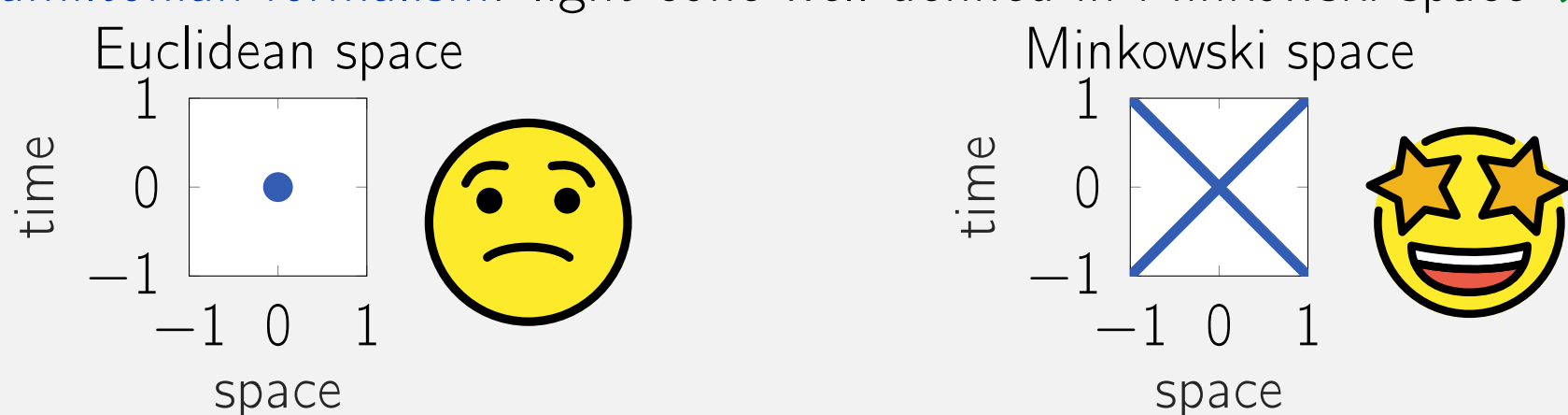

- \rightarrow tensor network states/quantum devices for direct computation of light-front matrix elements

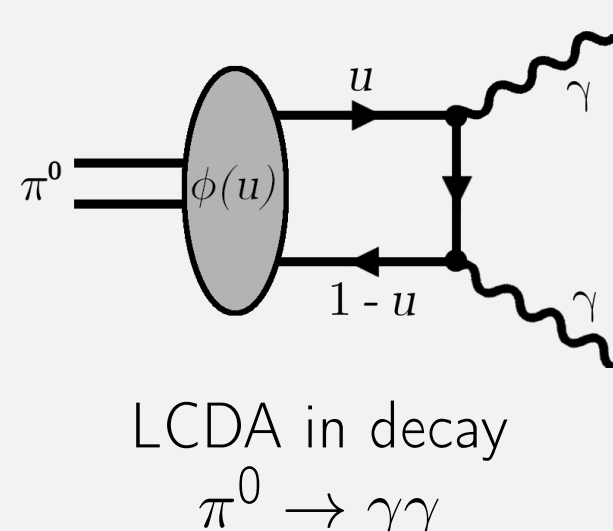
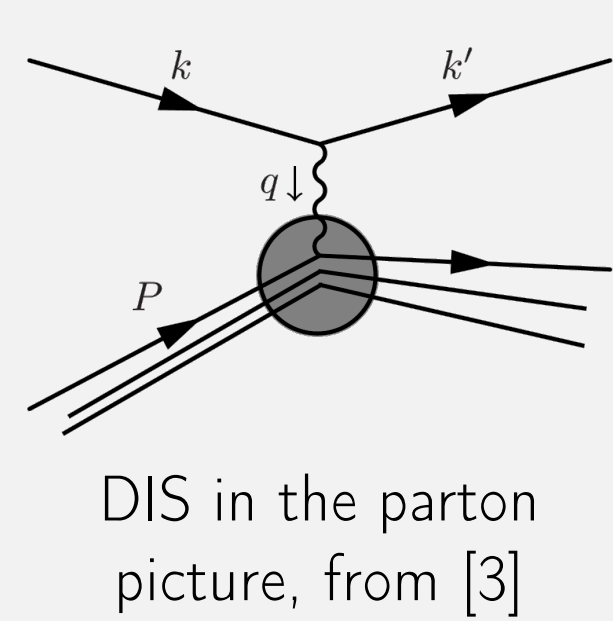
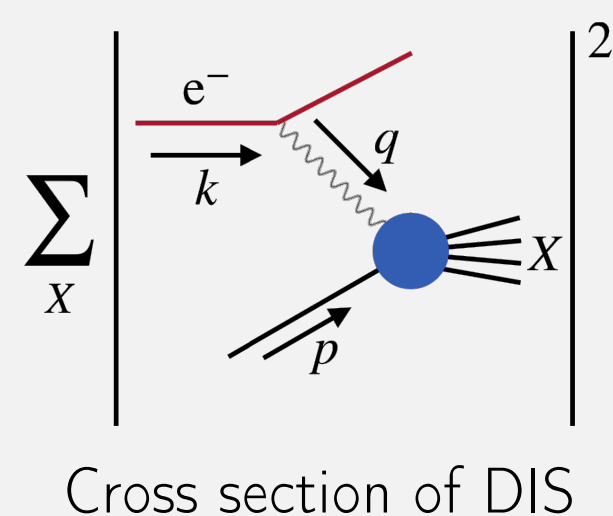

The Schwinger model

- quantum electrodynamics in 1+1 dimensions, $U(1)$ gauge symmetry
- shares many similarities with QCD: confinement, asymptotic freedom, dynamical mass generation
- fermion couples to gauge boson (\rightarrow partons), bound states (\rightarrow hadrons) [4] \Rightarrow can calculate PDF [5]
- Lagrange density:

$$\mathcal{L} = \bar{\Psi}(i\cancel{\partial} - g\hat{A} - m)\Psi - \frac{1}{4}F_{\mu\nu}F^{\mu\nu}$$

- in Hamiltonian formalism equivalent to spin-model ($x = \frac{1}{a^2 g^2}$, $\mu = \frac{2m}{ag^2} - \frac{1}{4}$ with lattice spacing a):

$$H = x \sum_{n=0}^{N-2} [\sigma_n^+ \sigma_{n+1}^- + \sigma_n^- \sigma_{n+1}^+] + \frac{\mu}{2} \sum_{n=0}^{N-1} [1 + (-1)^n \sigma_n^z] + \sum_{n=0}^{N-2} \left[\sum_{k=0}^n \left(\frac{1}{2} \left((-1)^k + \sigma_k^z \right) + q_n \right) \right]^2$$

Matrix elements consist of four contributions due to the staggered fermions, e.g.:

$$\langle P | \bar{\Psi}(z^-) \gamma^+ W(z^- \leftarrow 0) \Psi(0) | P \rangle \rightarrow \mathcal{M} = \mathcal{M}_{(e,e)} + \mathcal{M}_{(o,o)} - \mathcal{M}_{(o,e)} - \mathcal{M}_{(e,o)}$$

$$\mathcal{M}_{(e,e)} \propto \langle P | \sigma^+(z_e^-) W_{z^- \leftarrow 0} \sigma^-(0) | P \rangle$$

- evolution along light cone \rightarrow small time- and space-like steps
- time evolution with $N_T = \frac{T}{\delta\tau}$ Trotter steps:

$$e^{-i\tau H} \approx \left(e^{-i\delta\tau H_{eo}} e^{-i\delta\tau H_{oe}} e^{-i\delta\tau H_L} \right)^{N_T}$$

- spatial evolution: insert static charge q_n by operator Q_n^\dagger and move stepwise

$$\mathcal{M}_{(e,e)}(2n, 2m) = \langle P | e^{it_n H} \prod_{d < 2n} (-i\sigma_d^z) \sigma_{2n}^+ Q_{2n+1} \dots Q_{2m-3} \sigma_{2m-1}^- e^{-i\tau H_q} Q_{2m-1}^\dagger \prod_{d' < 2m} (i\sigma_{d'}^z) \sigma_{2m}^- | P \rangle$$

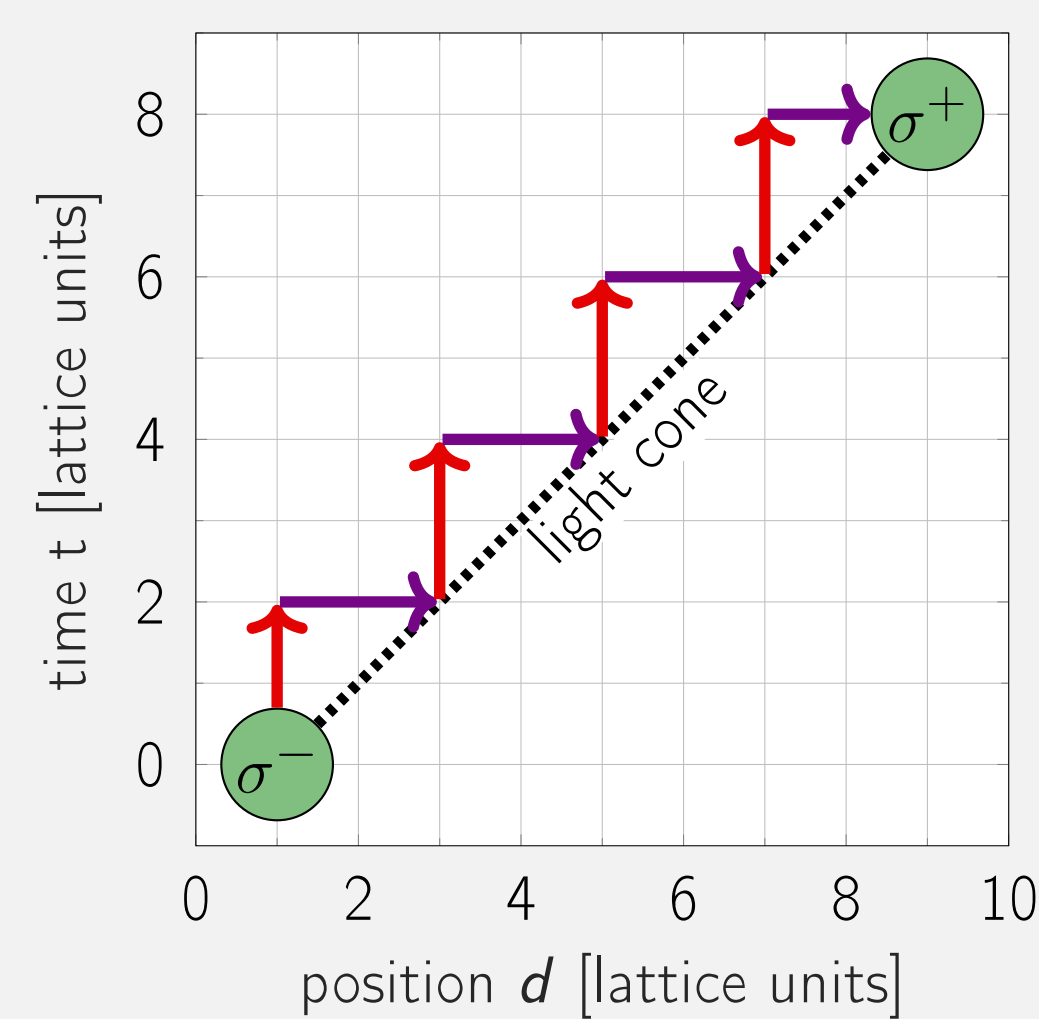

Tensor network states

- number of coefficients of state in Hilbert space grows exponentially:

$$|\psi\rangle = \sum_{s_1, s_2, \dots, s_N} \Psi^{s_1 s_2 \dots s_N} |s_1\rangle \otimes |s_2\rangle \otimes \dots \otimes |s_N\rangle$$

- tensor network state: local tensors as ansatz with polynomial resource scaling

$$\Psi^{s_1 s_2 \dots s_N} = \sum_{\{i_k\}=1}^D A_{i_1}^{s_1} \cdot A_{i_1, i_2}^{s_2} \cdot A_{i_2, i_3}^{s_3} \dots A_{i_{N-1}}^{s_N} = \bigcirc A^1 \bigcirc A^2 \bigcirc A^3 \bigcirc A^4 \dots \bigcirc A^N$$

- expressivity systematically controlled by bond dimension D
- matrix product state (MPS) in one spatial dimension: good approximation for low energy states
- Hamiltonian as matrix product operator (MPO):

$$H = \text{---} \bigcirc \text{---} \bigcirc \text{---} \bigcirc \text{---} \bigcirc \text{---}$$

- ground state (vacuum) and first excited state (vector meson) calculated by DMRG
- time evolution with tMPS:

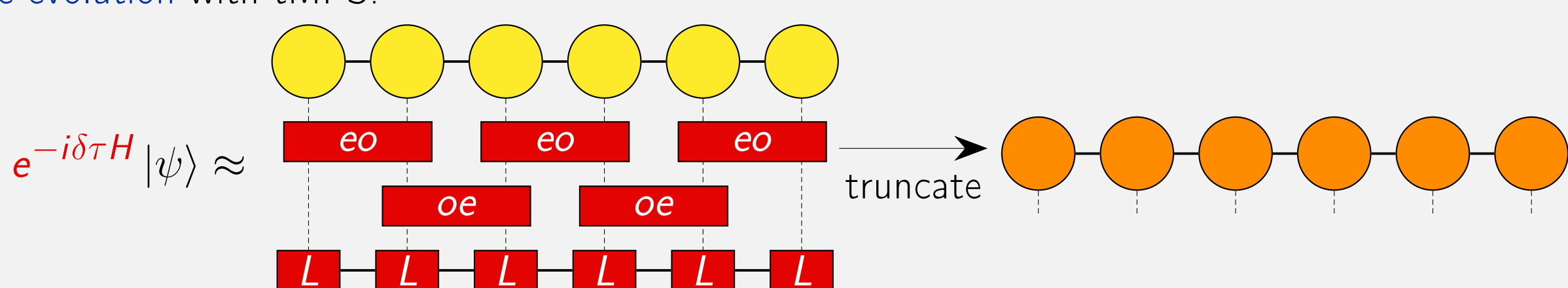

Results

Matrix elements for PDF:

- real part vanishes, imaginary part is antisymmetric \Rightarrow PDF is real as required
- vanishes for large distances \Rightarrow PDF can be obtained for arbitrary ξ by a continuous Fourier transform

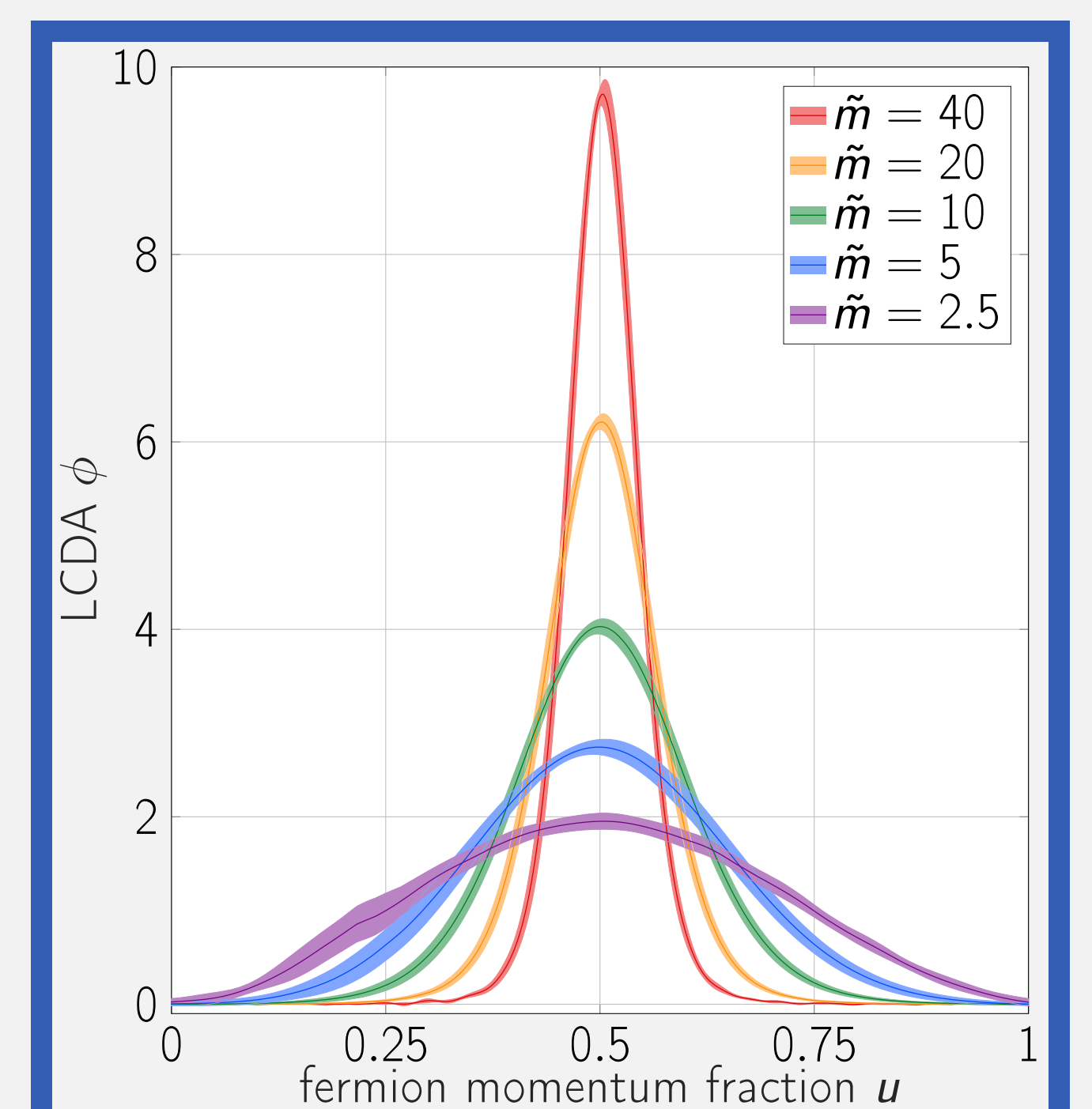
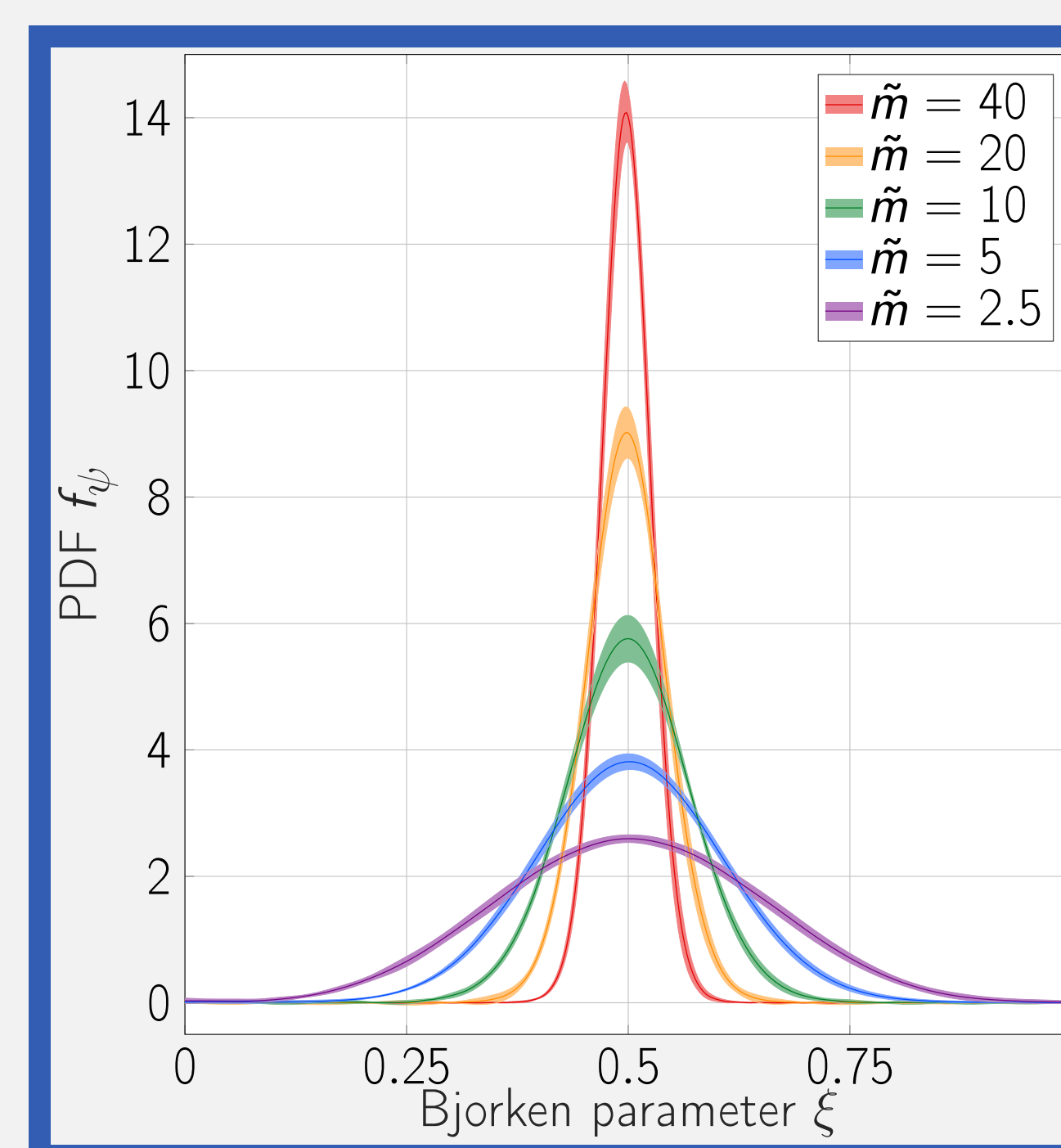
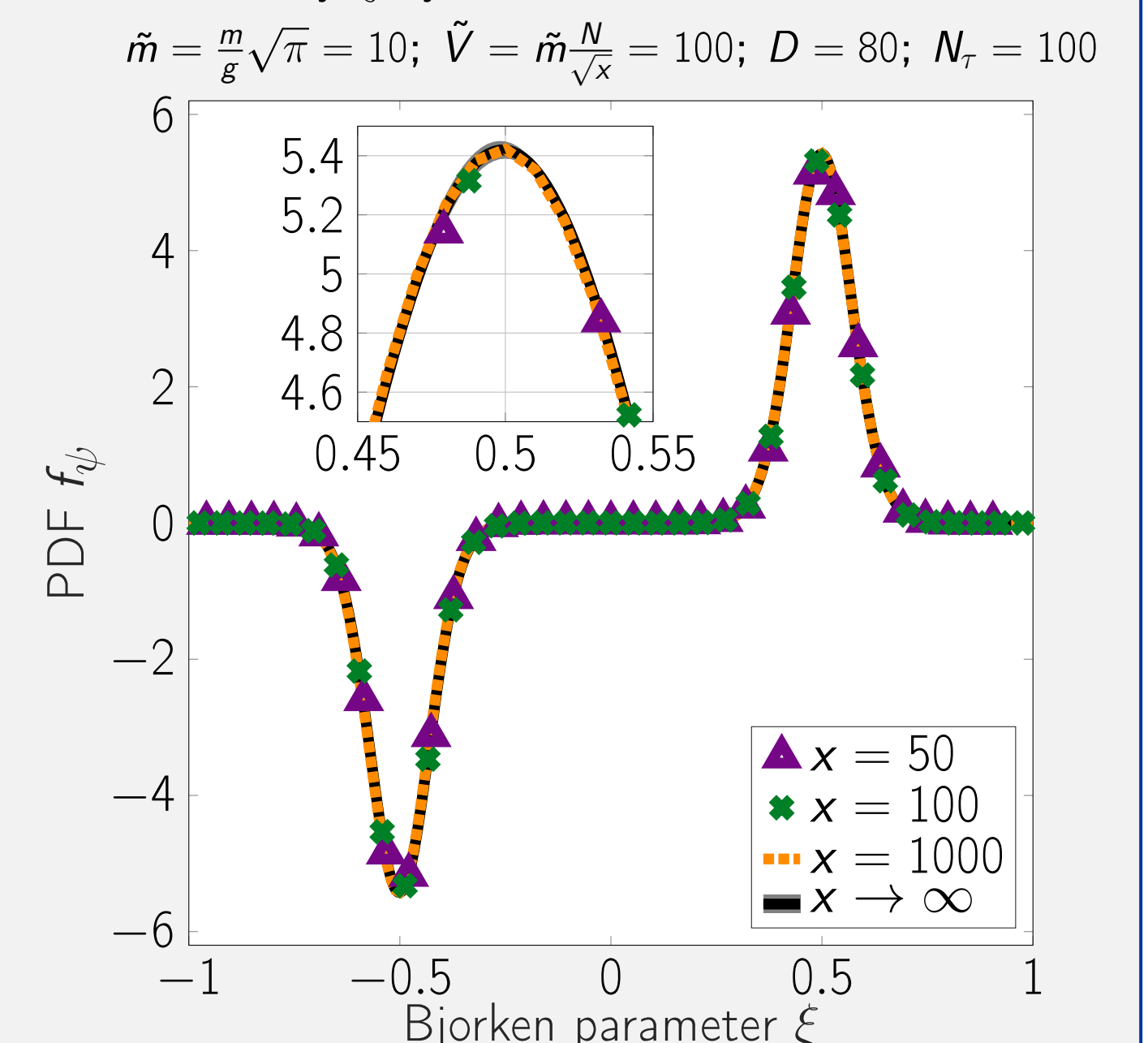
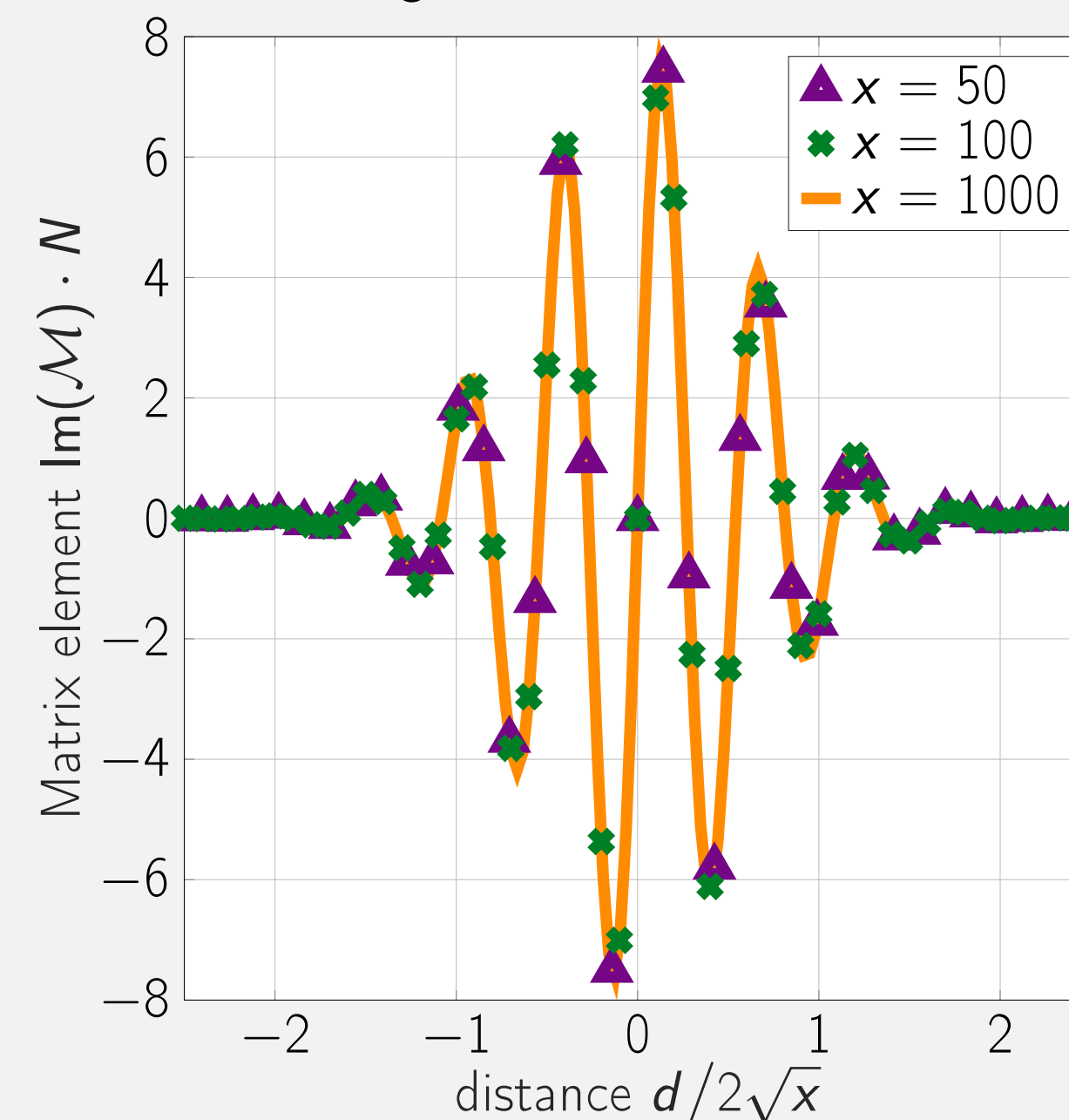

Results confirm physical properties of a meson:

- $0 \leq \xi \leq 1$: $f_{\psi} \approx$ symmetric around $\xi = 0.5 \Rightarrow$ fermions carry half of the meson momentum \checkmark
- $-1 \leq \xi \leq 0$: antiparticle PDF from negative ξ through $f_{\bar{\psi}}(\xi) = -f_{\psi}(-\xi)$.
- observed symmetry: $f_{\bar{\psi}}(\xi) = f_{\psi}(\xi)$: PDFs of fermion and anti-fermion are equal for a meson \checkmark
- peaks broaden with decreasing fermion mass; in agreement with $m \rightarrow 0$ where the PDF becomes a step function [5] and $m \rightarrow \infty$ where the PDF is a delta function. \checkmark
- all systematic errors well controlled (due to finite D , x , \tilde{V} , N_T and electric-field cutoff), see error bands
- LCDA: wider \rightarrow more sensitive to lattice artifacts \rightarrow extrapolate in x , estimate other errors
- PDF: narrower \rightarrow more sensitive to volume effects \rightarrow extrapolate in \tilde{V} , estimate other errors

Conclusion and outlook

We calculate parton distribution functions and lightcone distribution amplitudes in the Schwinger model from a direct evaluation of the light-cone matrix elements. This is not possible with Monte Carlo simulations in euclidean spacetime, where access to partonic functions is challenging and indirect methods need to be applied. Our approach provides a complementary way to obtain PDFs directly in Minkowski space. The Hamiltonian approach can be implemented on quantum computations as well.

Good accuracies are achieved in numerical simulations with tensor network states. The states can be expressed by an MPS with moderate bond dimensions of $D \sim 80$. The Wilson line is evolved along the light cone with a time evolution of the MPS. Systematic errors are controlled and the continuum- or thermodynamic limits can be reached. This demonstrates the applicability of tensor networks for dynamics of gauge theories. We obtain the PDFs of the fermion and anti-fermion as well as the LCDA for different fermion masses, and find the expected properties for the vector meson. This study marks a first step for parton physics in the Hamiltonian approach with tensor networks and lays a foundation towards higher dimensional gauge theories.

References

- M. C. Bañuls, K. Cichy, C.-J. D. Lin, and M. Schneider, "Parton distribution functions in the schwinger model from tensor network states", arXiv e-prints (2025) doi: 10.48550/arXiv.2504.07508, arXiv:2504.07508 [hep-lat].
- M. Schneider, M. C. Bañuls, K. Cichy, and C.-J. D. Lin, "Parton Distribution Functions in the Schwinger Model with Tensor Networks", in Proceedings of the 41st international symposium on lattice field theory — pos(lattice2024), Vol. 466 (2025), p. 024, doi:10.22323/1.466.0024, arXiv:2409.16996 [hep-lat].
- M. D. Schwartz, *Quantum Field Theory and the Standard Model*, (Cambridge University Press, Mar. 2014), doi:10.1017/9781139540940.
- M. C. Bañuls, K. Cichy, J. I. Cirac, and K. Jansen, "The mass spectrum of the schwinger model with matrix product states", *Journal of High Energy Physics* 2013, 158 (2013) doi:10.1007/JHEP11(2013)158, arXiv:1305.3765.
- J. Dai, J. Hughes, and J. Liu, "Perturbative analysis of the massless schwinger model", *Phys. Rev. D* 51, 5209–5215 (1995) doi:10.1103/PhysRevD.51.5209.



manuel.schneider@nycu.edu.tw

