

PoD: dynamically create and use remote PROOF clusters

A thin client concept

PROOF

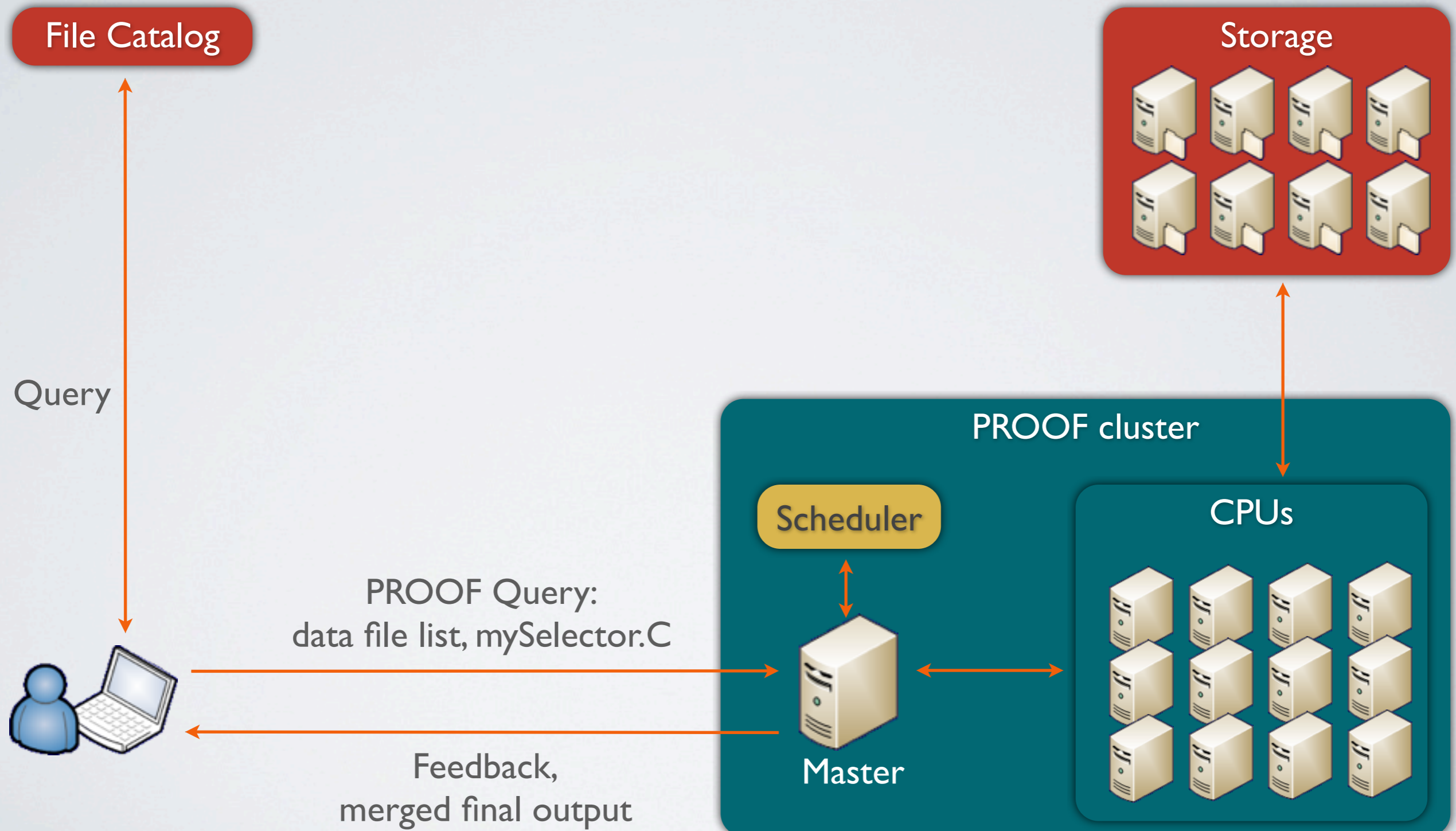

POD

PROOF on Demand

PROOF on Demand

POD

Different job managers



PoD is shipped with a number of plug-ins to cover all major RMSs, such as local cluster systems and Grid.

If there is no RMS available, then the SSH plug-in can be used.

The SSH plug-in is also used to setup PROOF clusters on Clouds.

Set your private PROOF cluster up

Start
PoD Server

pod-server start

Set your private PROOF cluster up



pod-server start

pod-submit -r [lsf | pbs | condor | ...] -q myqueue -n 100

or

pod-ssh -c pod_ssh.cfg submit

Set your private PROOF cluster up



`pod-server start`

`pod-submit -r [lsf | pbs | condor | ...] -q myqueue -n 100`

or

`pod-ssh -c pod_ssh.cfg submit`

`pod-info -l -n`

PoD vs “Static” approach

a User

- can entirely control his/her dynamic cluster,
- can setup and use it on demand,
- can dynamically change an amount of WNs,
- can select a preferable master host,
- doesn't need admins to take an action,
- doesn't disturb other users,
- is free to choose a ROOT ver. for services.

Binary Payload Attachment

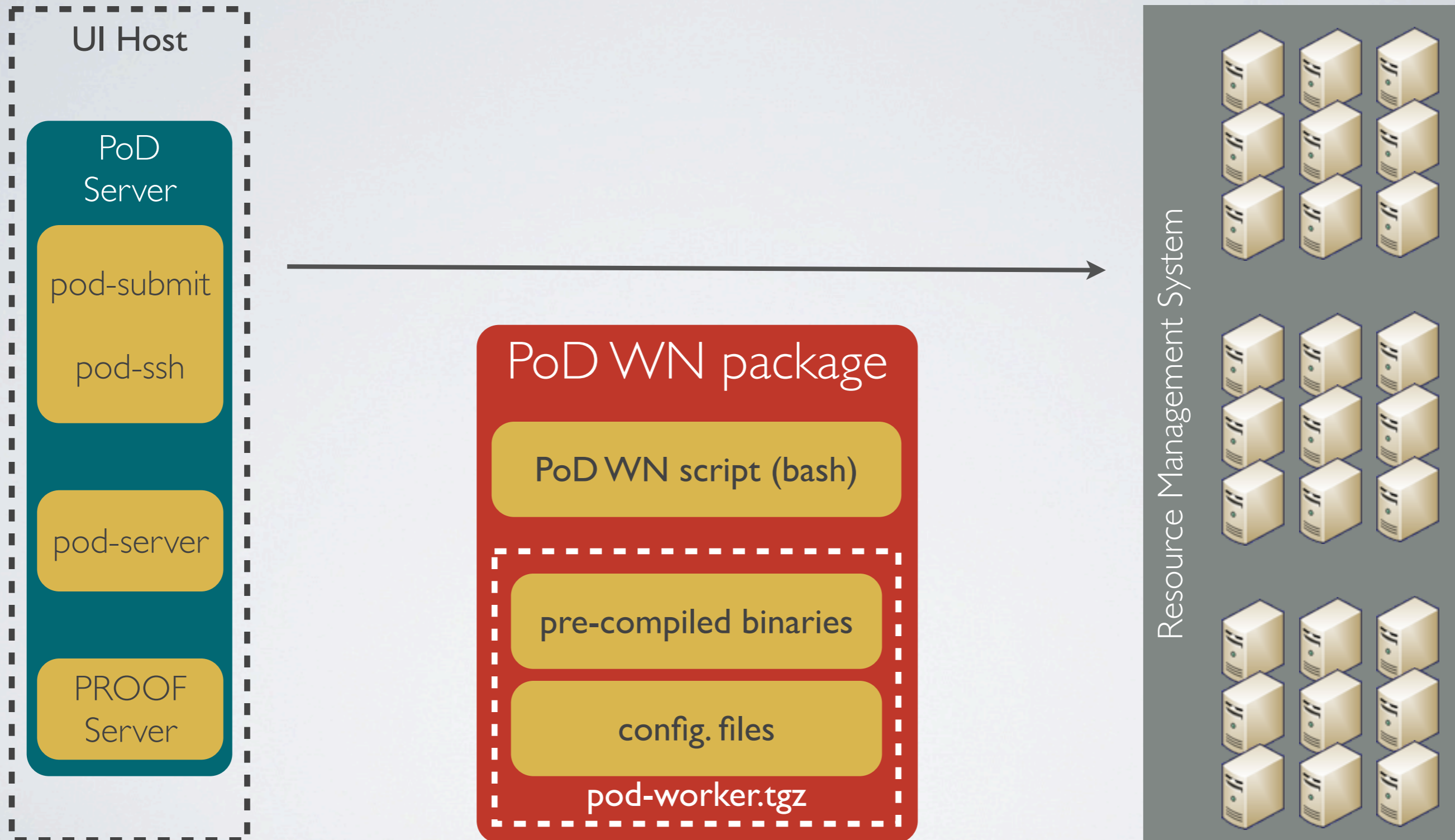

Binary Payload Attachment

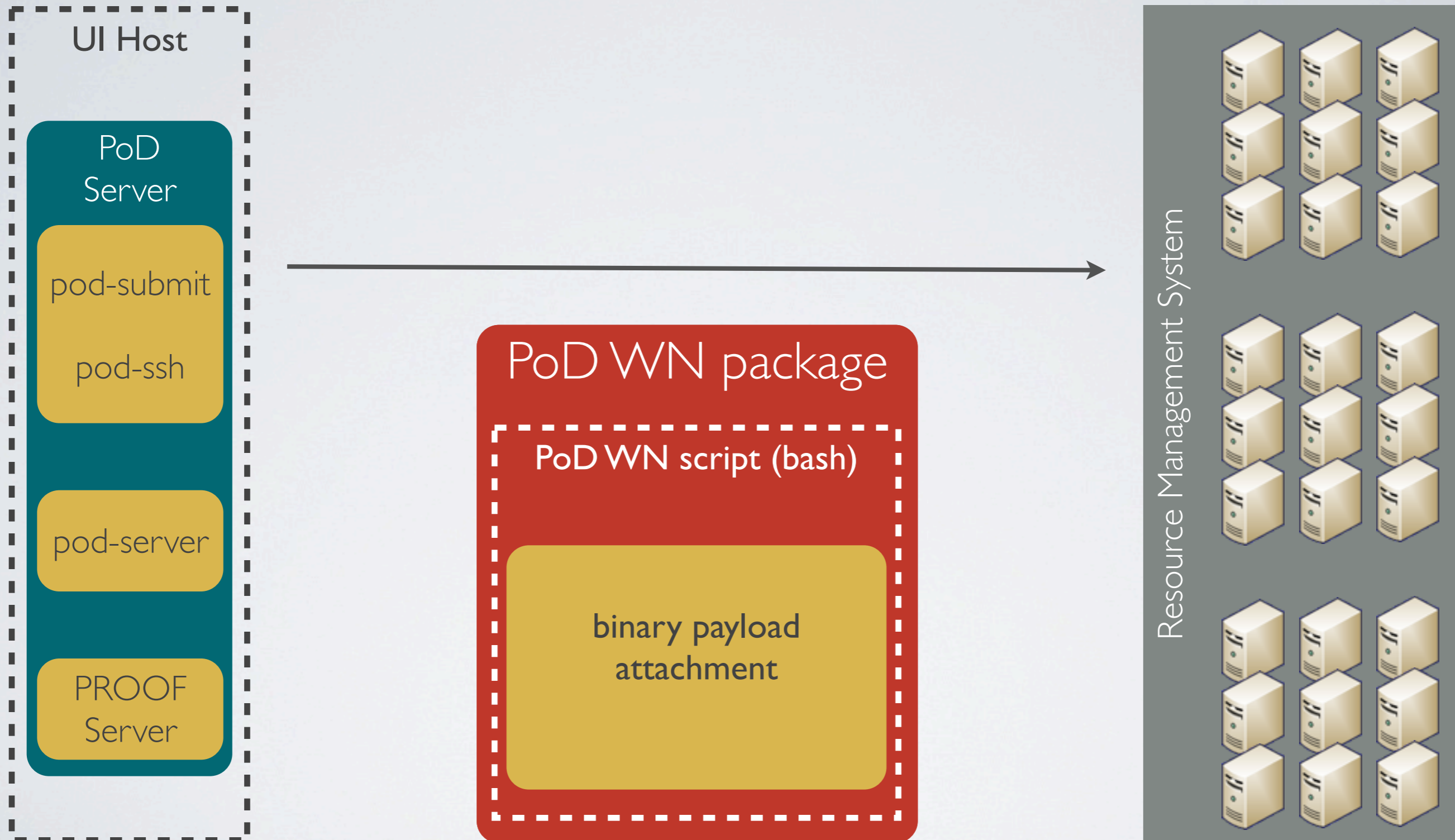

PoD SSH

a simple CSV file as an input to the plug-in:

ID,	login@host,	ssh params,	WN work dir,	num of proof WNs
r1,	anar@lxcg27.gsi.de,	-p24,	/tmp/test,	10
a2,	user@lxi001.kkk.es,		~/pod_wn,	
l4,	doom@host.my,	-p22,	/opt/pod/,	

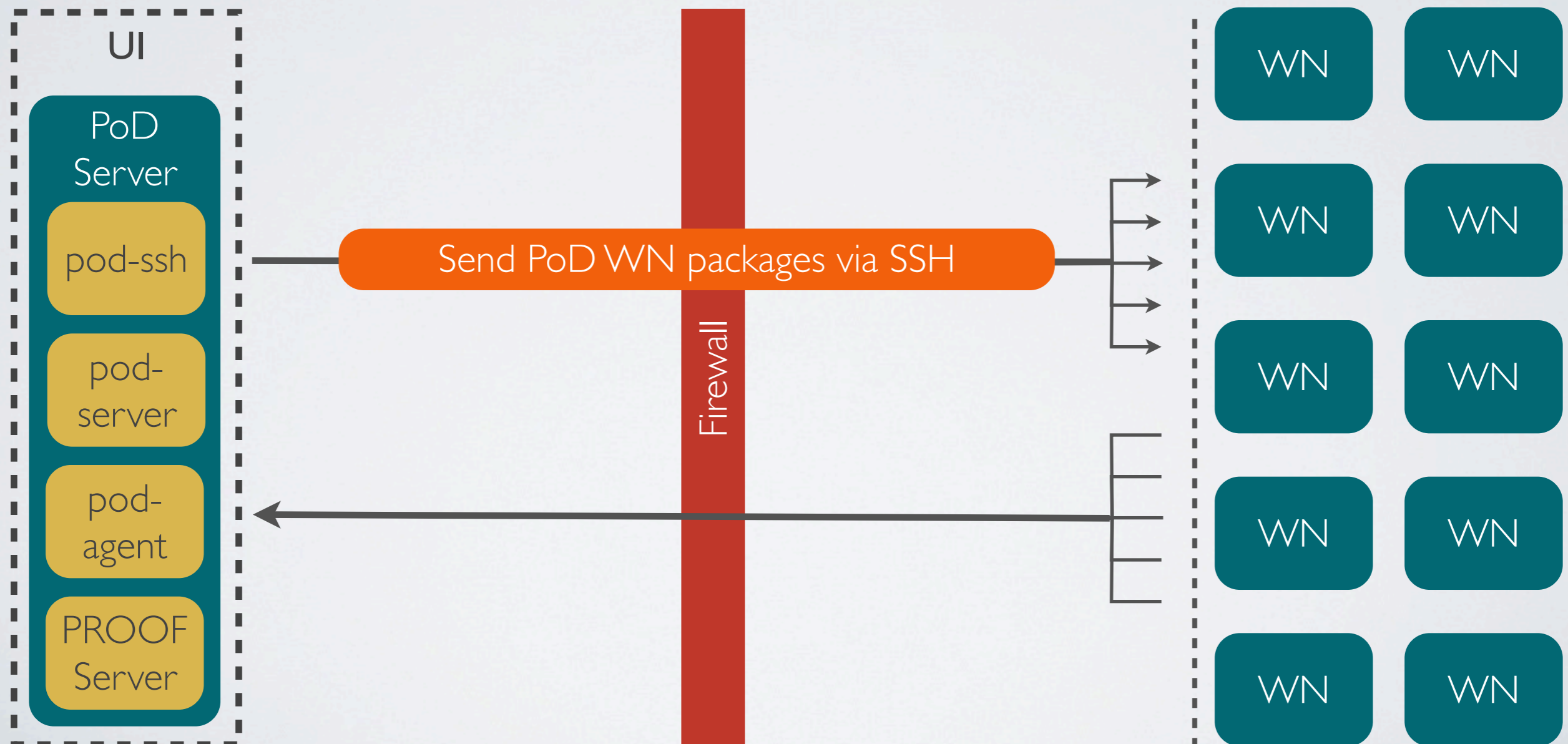

pod-remote: a thin client concept



pod-remote

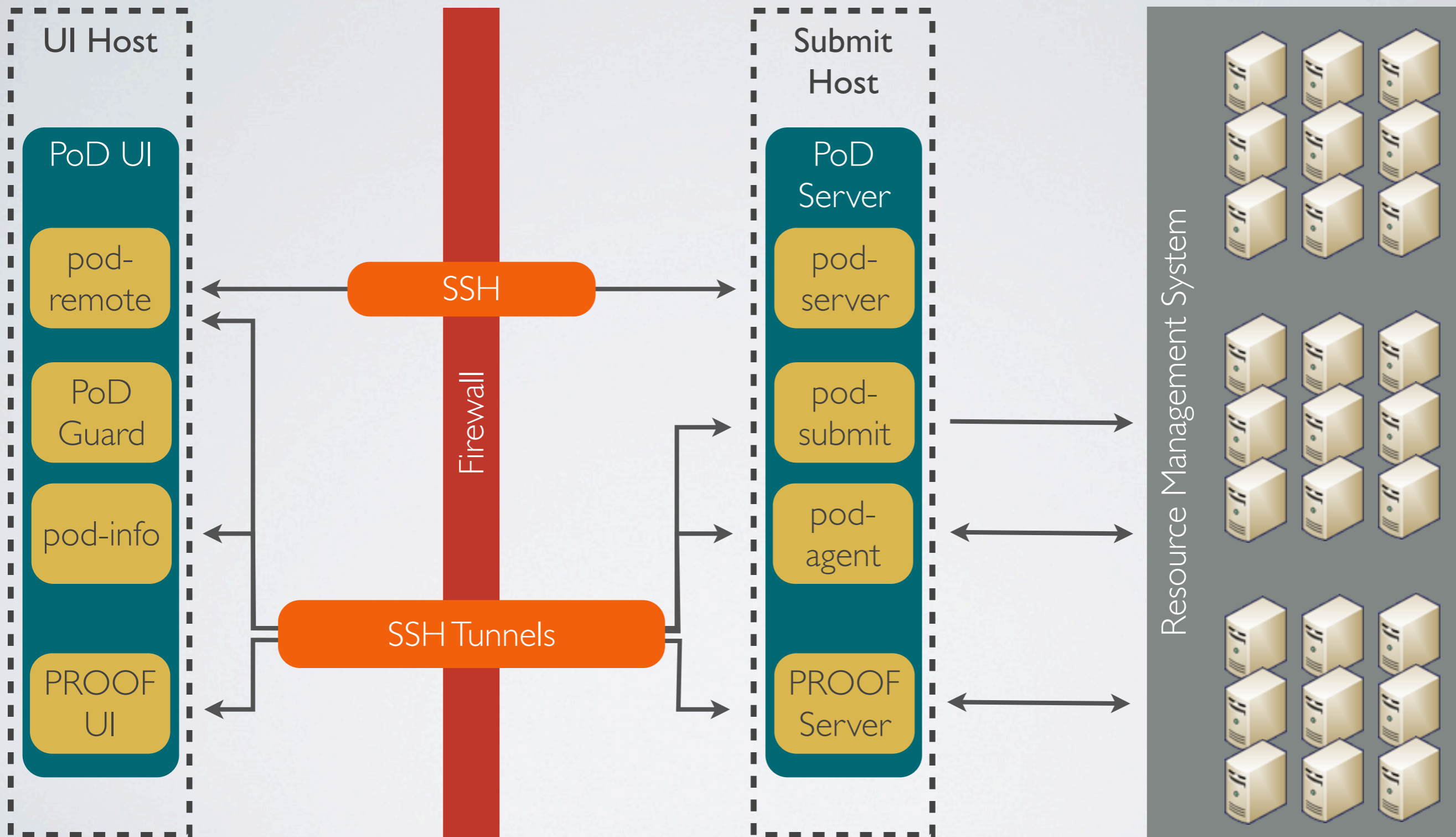

```
pod-remote --start \  
  --remote anar@host.gsi.de:/PoD/3.11 \  
  --env-local env_demac012.sh
```



```
pod-remote --start \  
            --remote anar@host.gsi.de:/PoD/3.11 \  
            --env-local env_demac012.sh
```

```
pod-info -sd
```

```
PoD Server Type: remote (managed by pod-remote)  
XPROOFD [47445] port: 21001  
PoD agent [47450] port: 22001  
PoD agent port is forwarded via local port: 22001  
XPROOFD port is forwarded via local port: 21001
```

```
pod-remote --start \  
            --remote anar@host.gsi.de:/PoD/3.11 \  
            --env-local env_demac012.sh
```

```
pod-info -sd
```

```
PoD Server Type: remote (managed by pod-remote)  
XPROOFD [47445] port: 2100 |  
PoD agent [47450] port: 2200 |  
PoD agent port is forwarded via local port: 2200 |  
XPROOFD port is forwarded via local port: 2100 |
```

```
pod-info -c
```

```
anar@localhost:2100 |
```



```
pod-remote --command "pod-ssh -c /home/etc/ssh_hst.cfg submit"
```

```
pod-remote --command "pod-ssh -c /home/etc/ssh_hst.cfg submit"
```

```
pod-info -ln
```

```
64
```

```
worker manafov@lxi049.gsi.de:21001 (direct connection) startup: 1s  
worker manafov@lxi049.gsi.de:21001 (direct connection) startup: 1s  
worker manafov@lxi049.gsi.de:21001 (direct connection) startup: 1s  
worker manafov@lxi049.gsi.de:21001 (direct connection) startup: 1s  
worker manafov@lxi049.gsi.de:21001 (direct connection) startup: 1s  
worker manafov@lxi049.gsi.de:21001 (direct connection) startup: 1s  
worker manafov@lxi049.gsi.de:21001 (direct connection) startup: 1s  
worker manafov@lxi049.gsi.de:21001 (direct connection) startup: 1s  
worker manafov@lxi054.gsi.de:21001 (direct connection) startup: 2s  
worker manafov@lxi054.gsi.de:21001 (direct connection) startup: 2s  
worker manafov@lxi054.gsi.de:21001 (direct connection) startup: 2s  
worker manafov@lxi054.gsi.de:21001 (direct connection) startup: 2s
```

```
...
```



```
TProof::Open(gSystem->GetFromPipe("pod-info -c"));
```

```
TProof::Open(gSystem->GetFromPipe("pod-info -c"));
```

```
TProof::Open("pod://")
```



```
TProof::Open(gSystem->GetFromPipe("pod-info -c"));
```

```
TProof::Open("pod://")
```

```
pod-remote --stop
```

no need to write all arguments when using
pod-ssh, pod-remote

```
pod-remote --start \  
  --remote anar@host.gsi.de:/PoD/3.11 \  
  --env-local env_demac012.sh
```

```
pod-remote --command "pod-ssh -c /home/etc/ssh_hst.cfg submit"
```

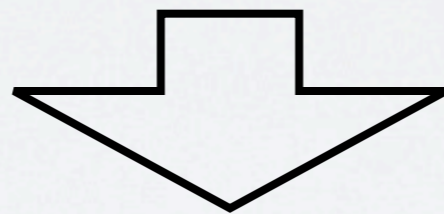

```
pod-remote --start  
pod-remote --command "pod-ssh submit"
```

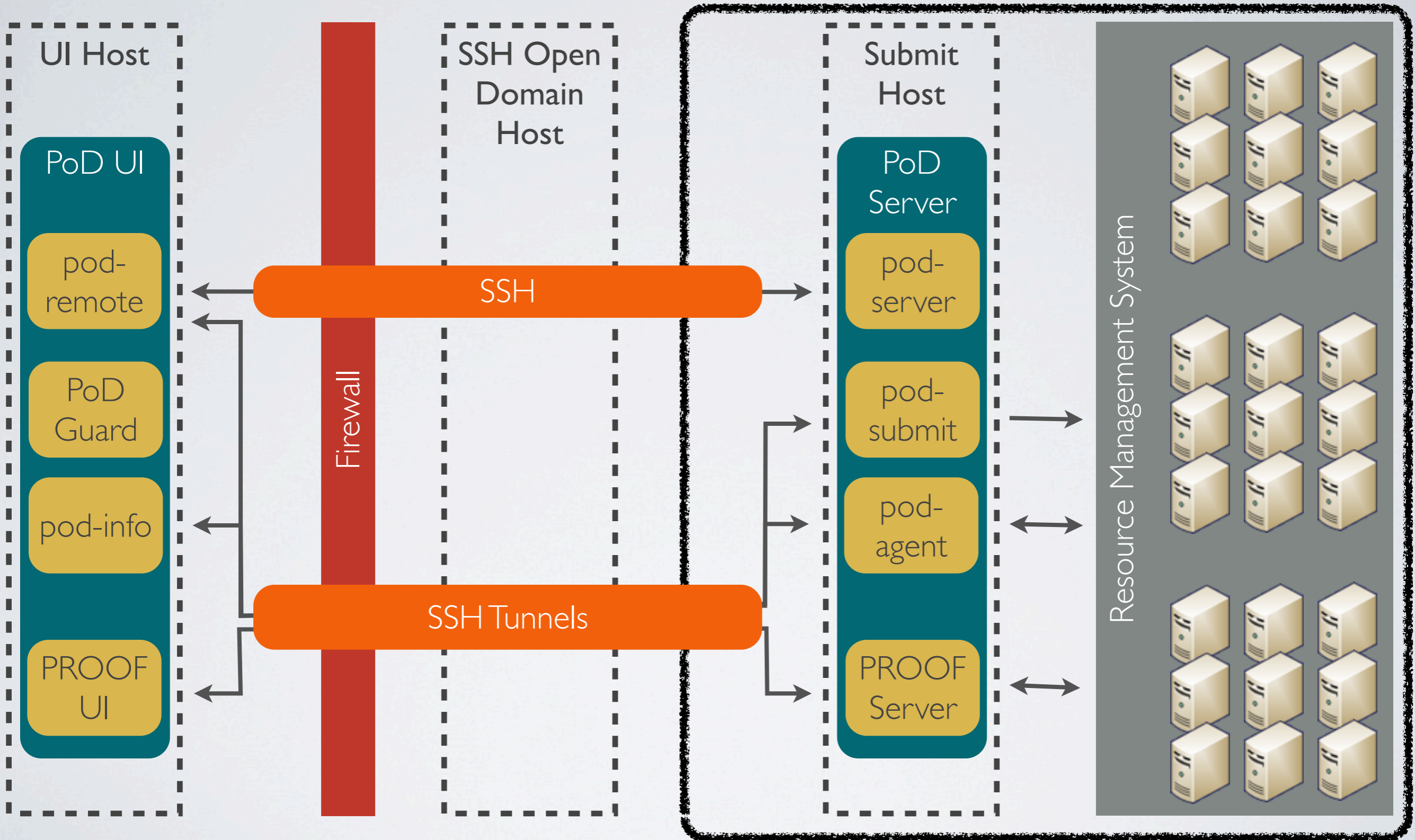

pod-remote: via open domain

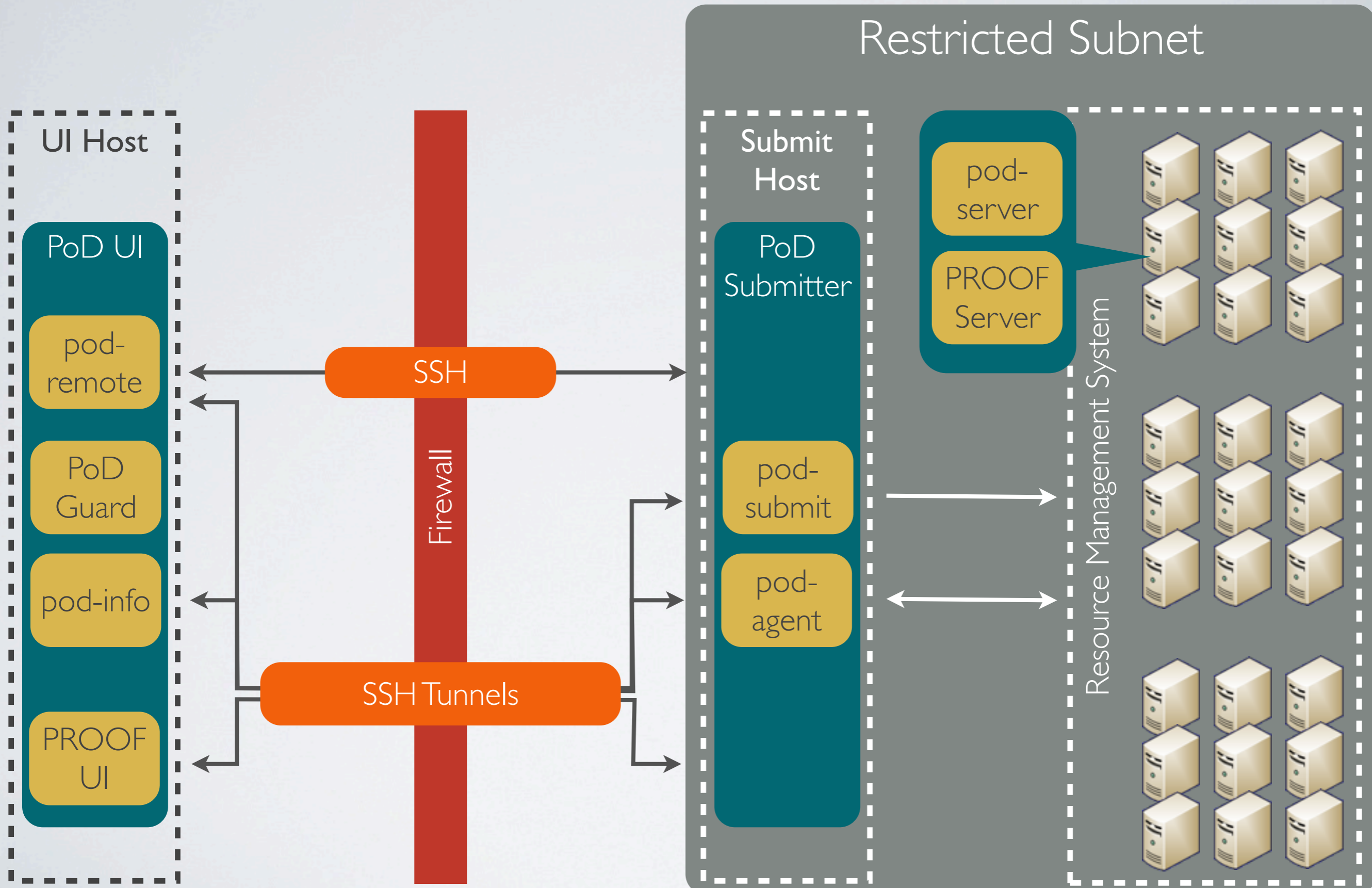

Dynamic Master architecture

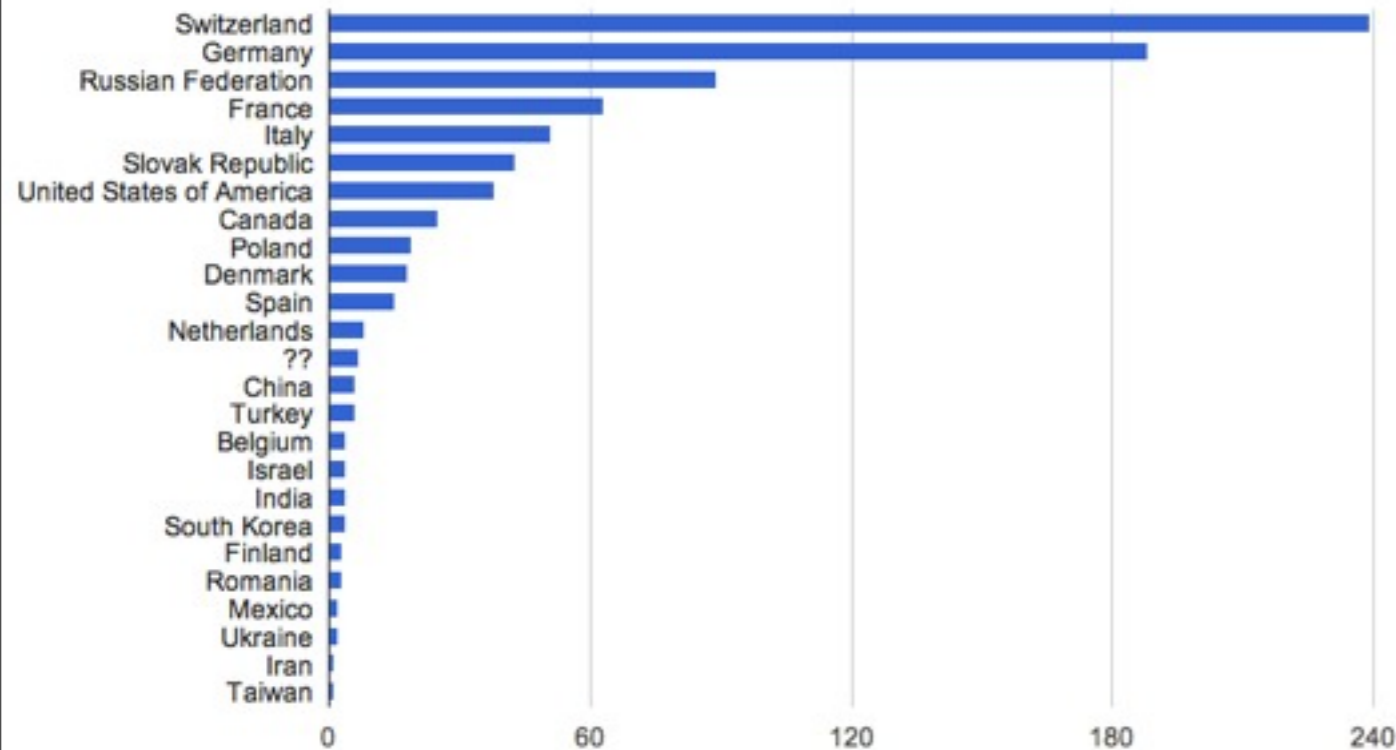

Downloads by Country



~**900** Downloads since June, 2010
24 countries
~**200** Unique Downloads per year

Downloads by Versions (accumulated by minor numbers)

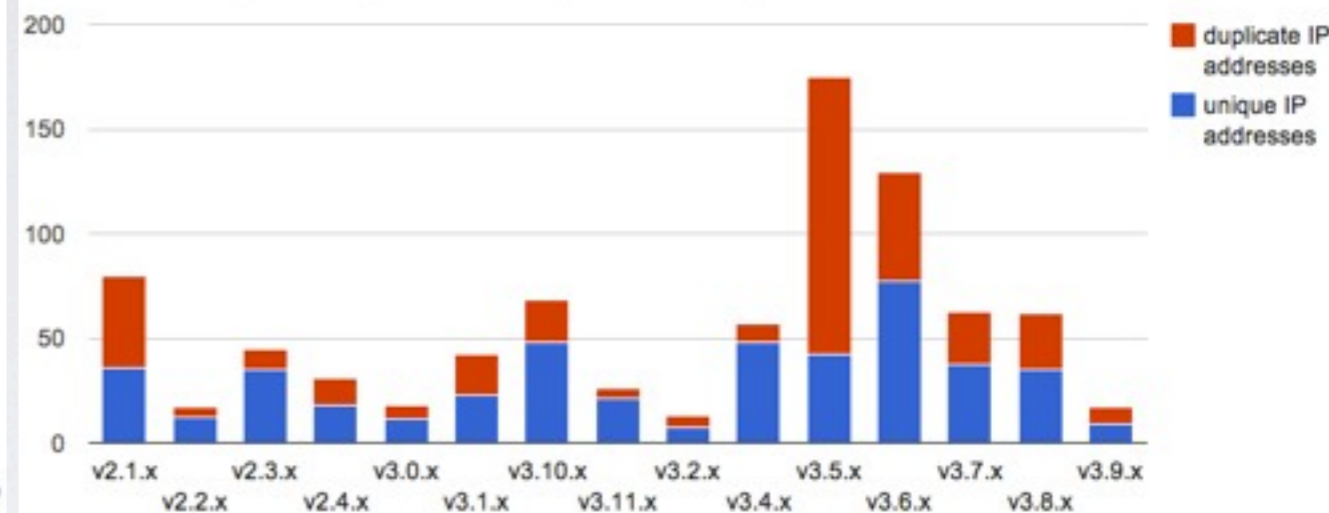

PoD is now officially a part of ATLASLocalRootBase package:

https://twiki.atlas-canada.ca/bin/view/AtlasCanada/ATLASLocalRootBase#Using_PROOF_on_Demand_PoD

PoD related Posters (Track 3, CHEP 2012)

- **Computing On Demand: Dynamic Analysis Model** >> **with LIVE DEMOs!!!**
- Dynamic parallel ROOT facility clusters on the Alice Environment
- Enabling data analysis à la PROOF on the Italian ATLAS-Tier2's using PoD
- Integrating PROOF Analysis in Cloud and Batch Clusters
- PEAC - A set of tools to quickly enable PROOF on a cluster