

# Ion Source Requirements

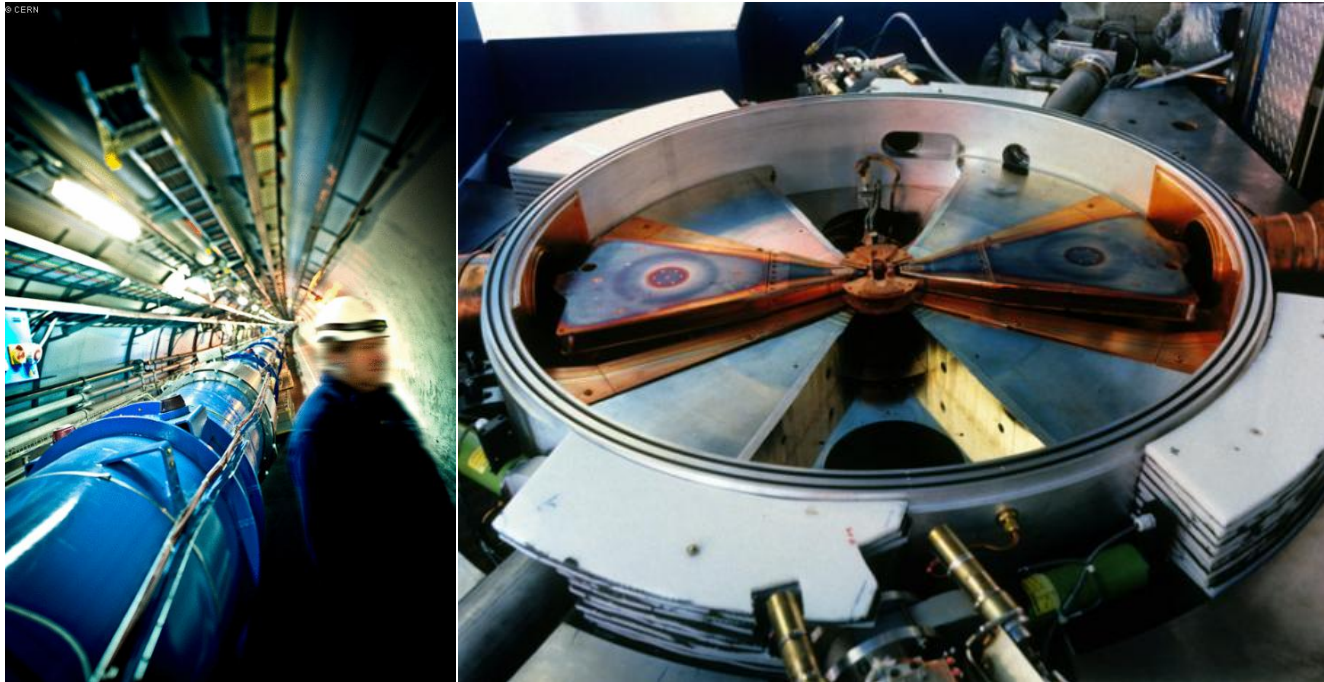

Richard Scrivens

CERN

CAS on Ion Sources, May 2012

# Layout

What is an ion source?

What do we need to make them work?

What are the requirements (parameters)?

Some basics of plasma dynamics – to understand sources.

# What are we going to discuss

Ion sources have many uses.

We are going to concentrate on the ion sources used for particle accelerators (this is the CERN Accelerator School).

# What are we going to discuss

From the small  
and beautiful...

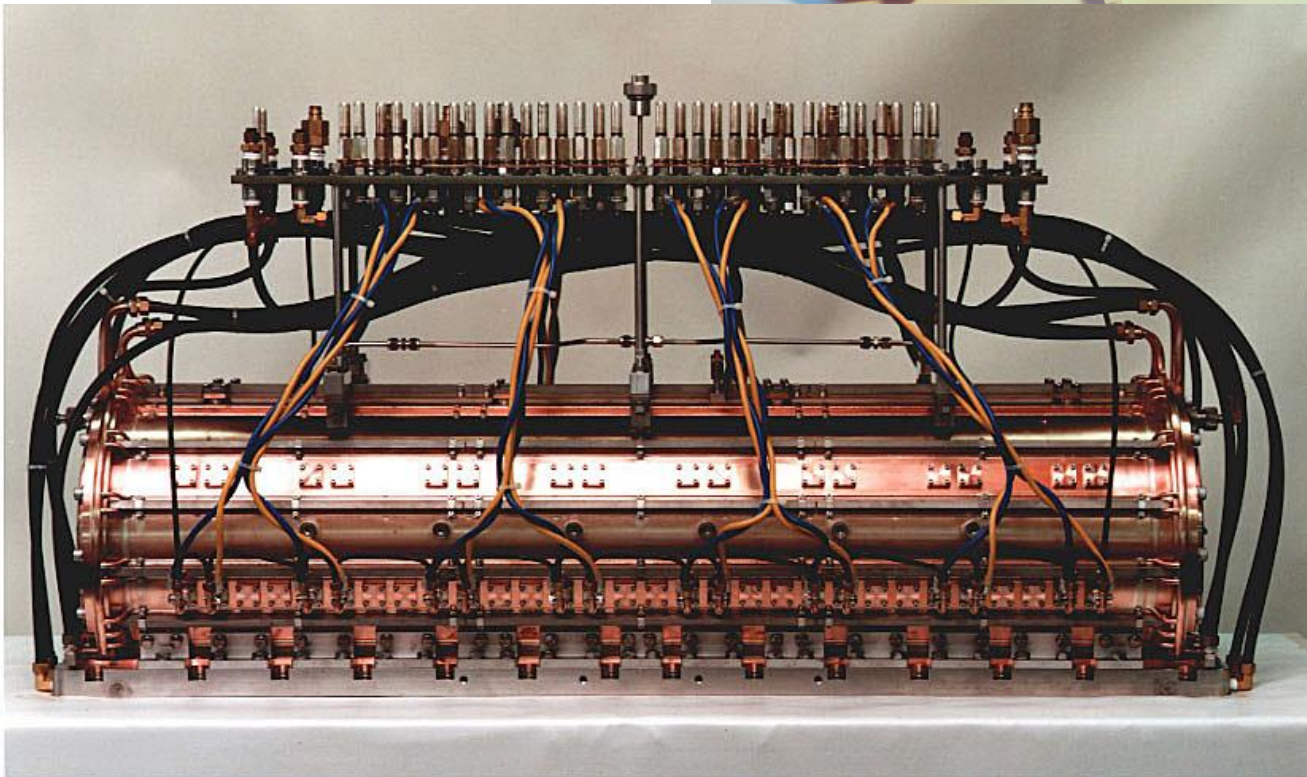
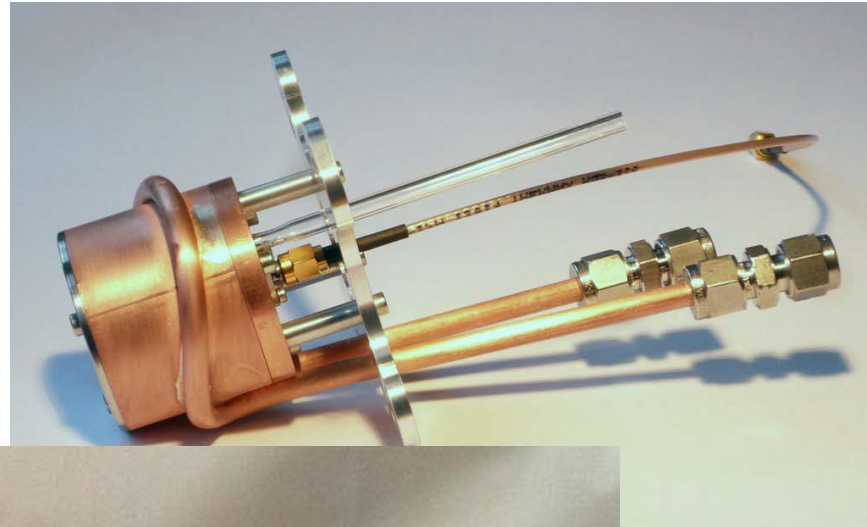

to the large  
and impressive

# An Ion?

An atom or molecule with a charge.

i.e. with the removal or addition of one or more electrons.

Electric and magnetic fields then apply strong forces to the ion.

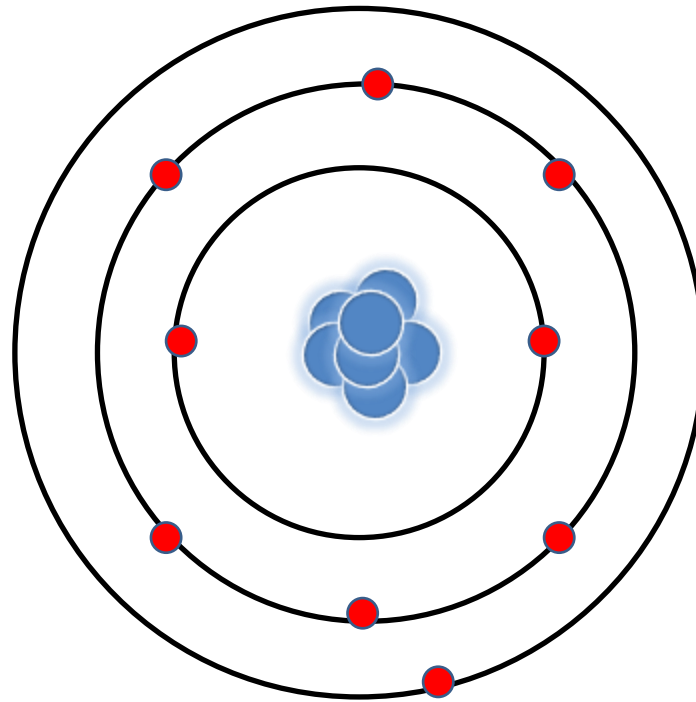

# What is a source made of?

There is no single drawing of an ion source, such are the variations in their approaches. But typically.

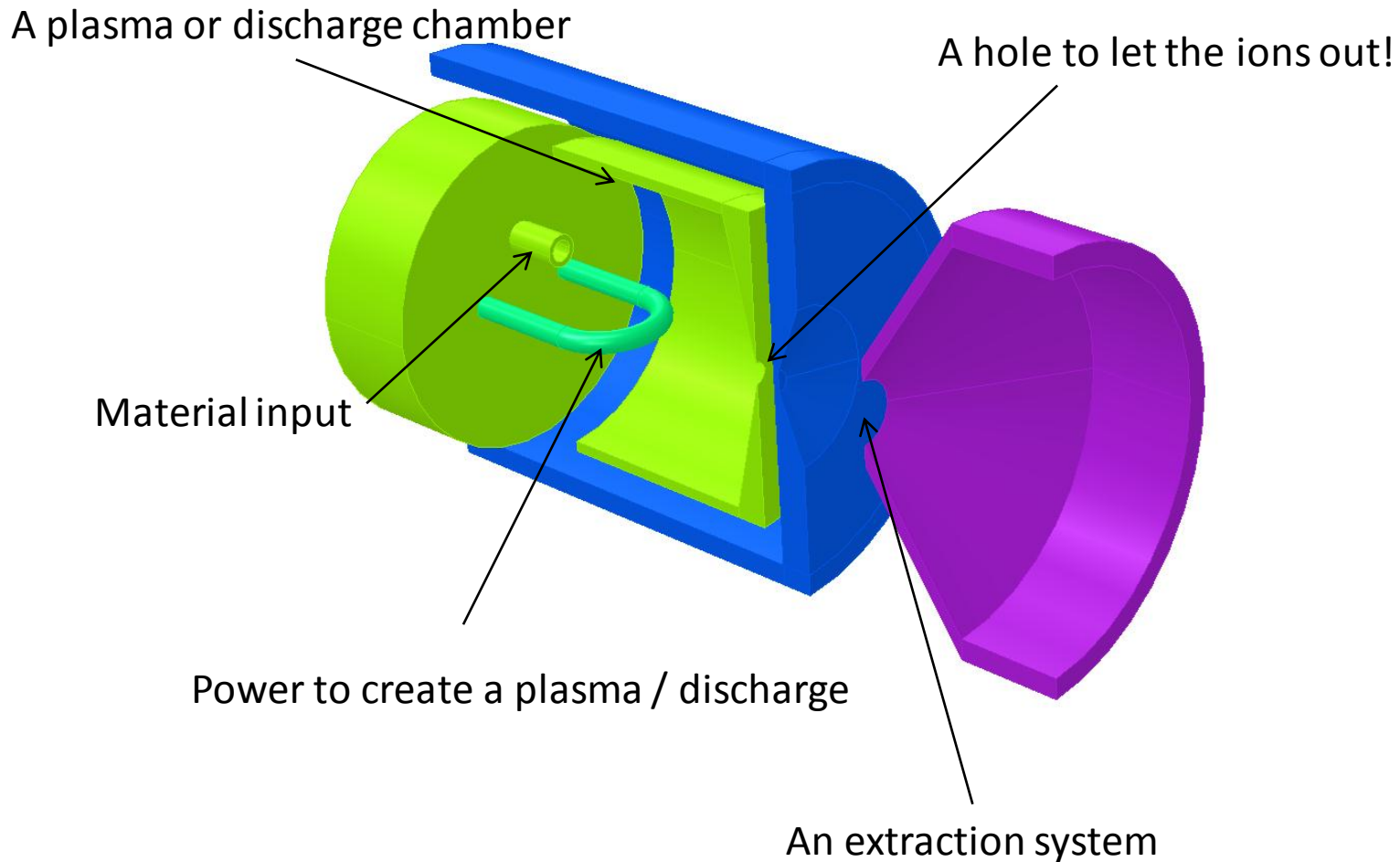

# What Else Is Needed...

Power Source  
Power Supplies / RF / Laser



Vacuum Pumping



Cooling



Plasma diagnostics

Beam diagnostics



Interlocking +  
Safety Systems



# Particle Type

The most fundamental parameter of your source – End of story

Or is it?

Protons ... or  $H^-$  ... or  $H_2^+$ ,  $H_3^+$  ...

C ...  $C^+$  ...  $C^{n+}$

Or  $CO^+$

Does the user need a range of types, how often and quickly do they need to change...

And in the end the experiment might be more flexible ... Si might be negotiated to Ar...



# Energy 1

$^{20}\text{Ne}^{5+}$   
100kV

Total ion energy after extraction

$$E_{total} = qeV$$

500keV

$8 \times 10^{-14}$  J

Energy per nucleon

$$E/nucleon = qeV/A$$

25.01keV

Defines a charge and mass independent velocity  
(if A is the real mass number)

For RF Linacs: It is easy to work out V for a given  
q & A (linear scaling).

The above are normally quoted in eV  
the electron charge is in the units

Extraction voltage

$$E_{extraction} = V$$

100kV

# Energy 2

Does the user have a specific energy in mind from the source, for a specific application (surface modification for example).

## High Beam Energy Advantages

- Space Charge Reduced – Higher beam currents possible.
- Reduces energy spread ratio ( $\Delta E/E$ ).
- Reduces the geometrical emittance => smaller apertures?
- Higher velocity makes it easier to inject into an RF accelerator (e.g. DTL).

## High Beam Energy Disadvantages

- Technically Difficult.
- Higher risk of sparking
- Longer RFQ (input cells become longer)
- Higher fields for beam devices.
- Higher Energy = Higher Beam Power => consequences for beam intercepting devices.

# Intensity

Beam intensity from source (and Linacs) are almost always quoted in terms of the beam current.

$$I_{electric\_current} = \frac{qeN_{ions}}{t}$$

Multiple charge state sources can be quoted in terms of the particle current, which eases comparison of sources of different charge states.

$$I_{particle\_current} = \frac{eN_{ions}}{t} = \frac{I_{electrical\_current}}{q}$$

It is usual to give the beam peak current for a pulses source, along with its time structure.

# Repetition Rate

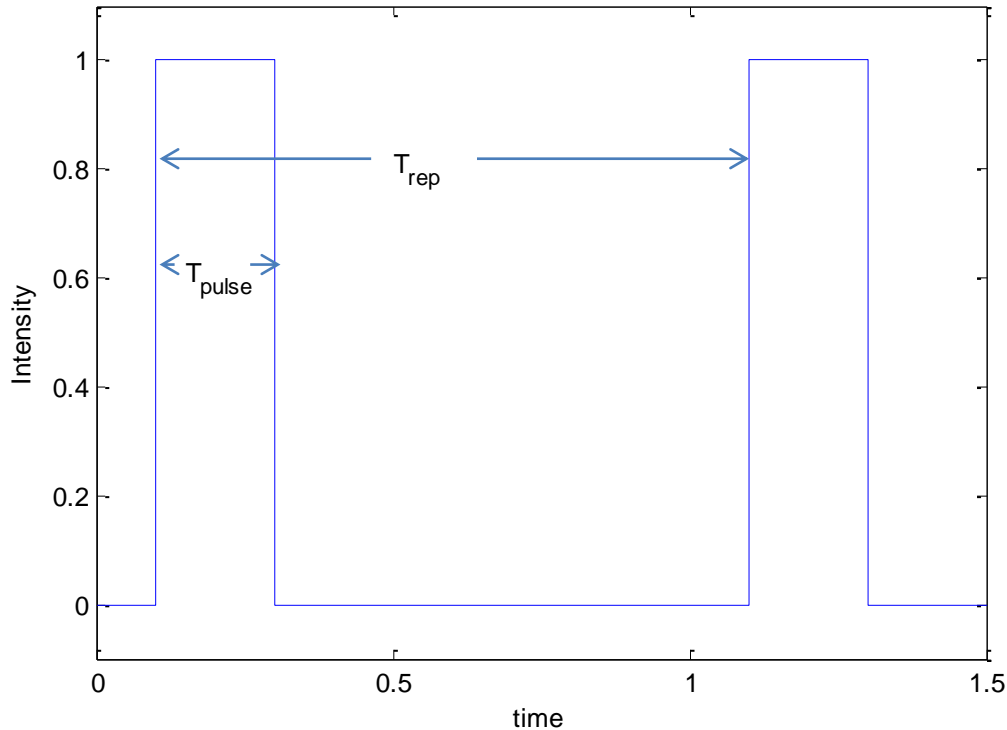

$$\text{Repetition Rate} = \frac{1}{T_{rep}}$$

$$\text{Pulse length} = T_{pulse}$$

$$\text{Duty factor} = \frac{T_{pulse}}{T_{rep}}$$

Beam currents are usually quoted as the average over the pulse.  
(But can sometimes be an average – if in doubt, ask!)

# Space Charge

The beam is repulsed by its own space charge.

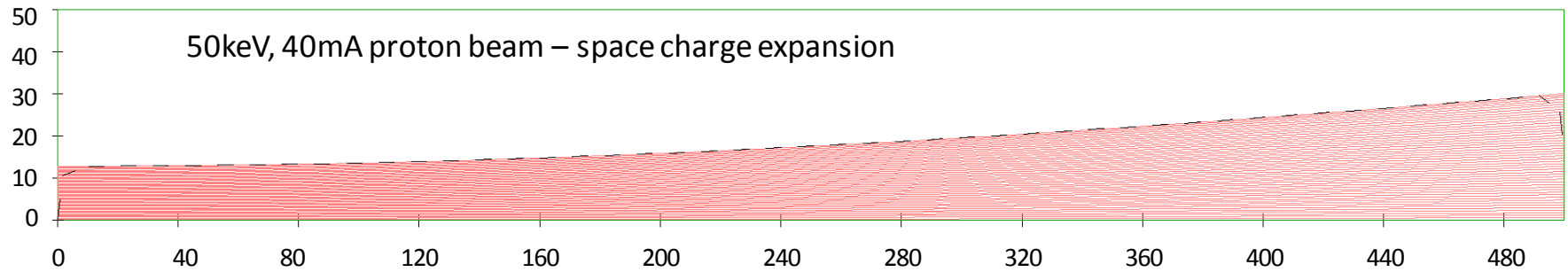

# Space Charge

Beams can be compared through several definitions:

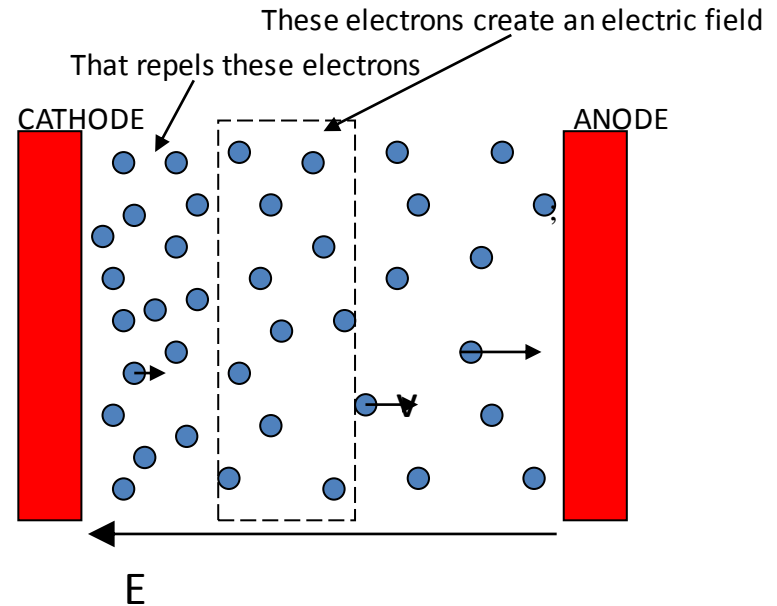
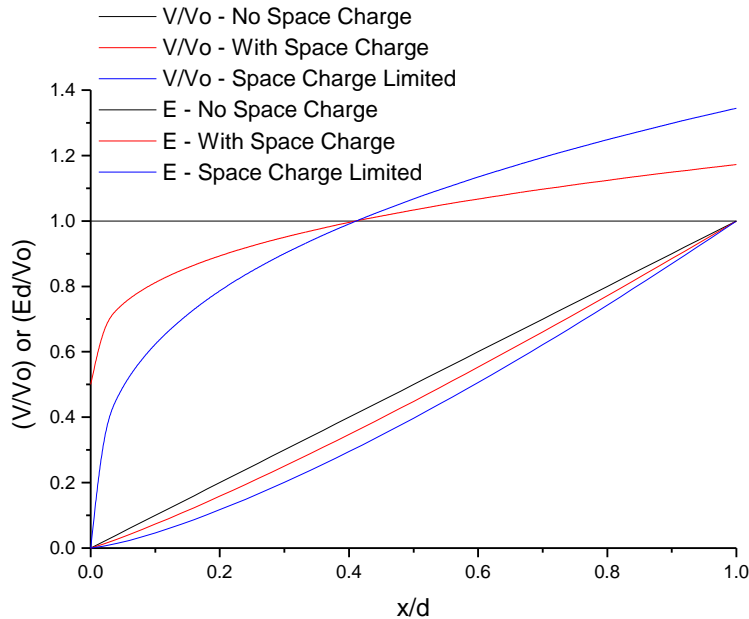

$$J_{CL} = \frac{4}{9} \epsilon_0 \sqrt{\frac{2qe}{m}} \cdot \frac{U_d^{3/2}}{d^2}$$

- Child-Langmuir limit comes from the maximum current density of electrons that can be extracted from an (infinite) plane surface, to an anode distance  $d$  away.
- Correcting for the ion mass, the same formula indicates the voltage and distance necessary for your ion source.

# Space Charge

- The propagation of an electron beams due to space charge is only dependent on the beam perveance.

$$P = \frac{I}{U^{3/2}}$$

- For ions we need to take into account the ion mass.
- Therefore the perveance is “normalised” using the Child-Lagmuir constant ... giving rise the poissance

$$\Pi = \frac{9}{4\epsilon_0} \frac{I}{U^{3/2}} \sqrt{\frac{m}{2qe}} \cdot \frac{a}{b}$$

$\frac{a}{b}$  Ratio of the beam  
width to height

- If  $\Pi = 1$  you already have a beam with significant space charge!
- Some counter-intuitive conclusions, for a given  $I$ ,  $U$  and  $m$ , poissance decreases with  $q$  (attention, the particle current decreased!)
- Scaling we see a 40mA, 50keV proton beam has the same  $\Pi$  as a 0.2mA, 5keV Ar+

# Space Charge - Compensation

Nature has been kind to low energy beam transport of high intensity beams.

The particle beams can ionize the residual gas left in the beam line.

The resulting electrons and ions are contained by the potential of the beam.

The trapped particles suppress the beams own space charge, allowing it to be more easily transported.



# Emittance 1

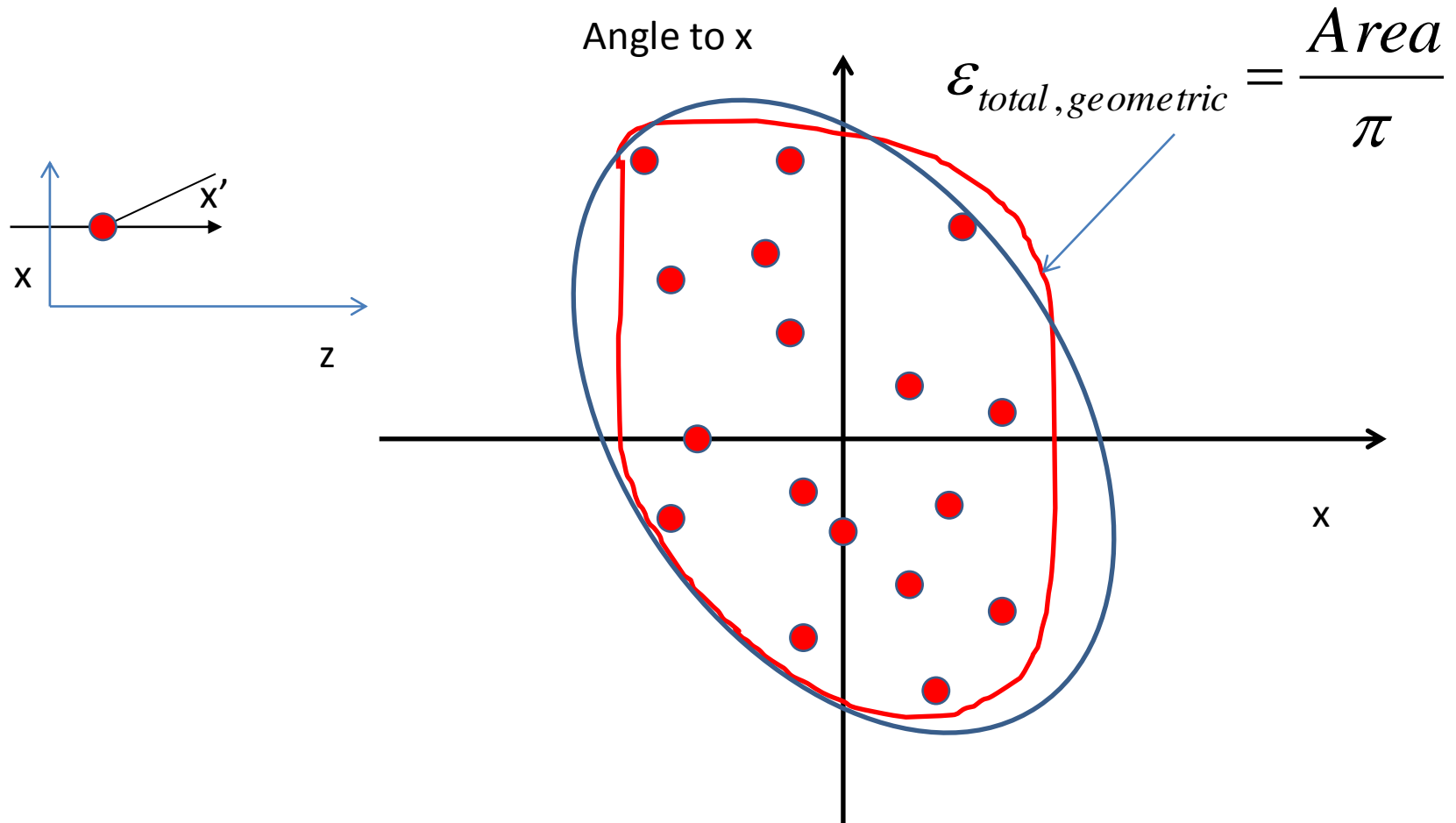

If you see  $100 \pi$  mm.mrad, the AREA is  $100\pi$ , and the emittance is 100  
If you see 100 mm.mrad, the AREA is  $100\pi$ , and the emittance is 100

# Emittance 1b

Even clever people continue to add to the confusion...

CAS proceedings – Transverse Beam Dynamics – E.J. Wilson

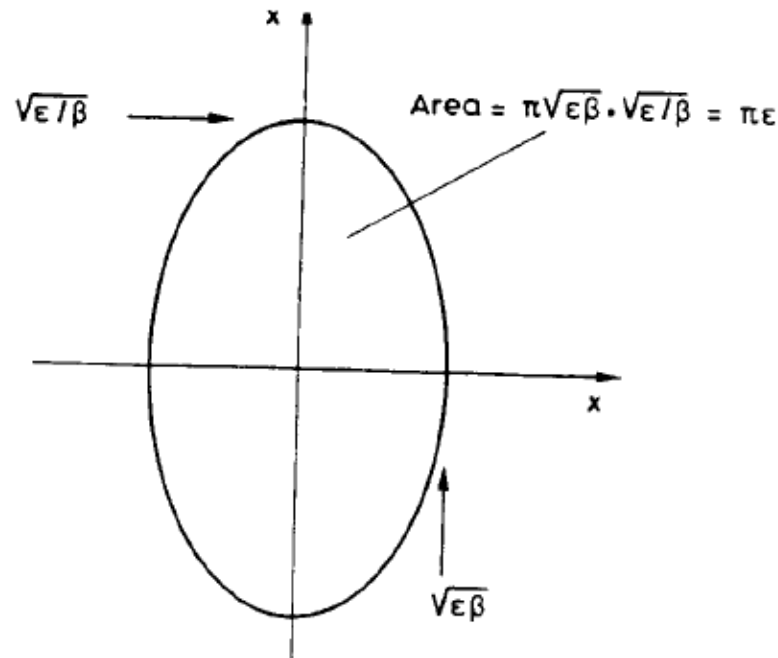

The area within the contour is proportional to the emittance of the beam. At constant energy we express this as the area  $\epsilon = \int y' dy$  in units of  $\pi$ .mm.milliradians. We have shown

# Emittance 2

The beam emittance requirement can come for the use:

- In a collider it leads to the luminosity.
- Smallest spot size for particle beam at and experiment target (or beam diagnostic).
- In an accelerator, it defines the aperture requirement (which can increase the size and cost of quadrupoles, RF cavities...)
- Definition of the RMS emittance (geometric).

$$\epsilon_{rms} = \frac{1}{N^2} \left\{ N \sum x^2 - (\sum x)^2 \left[ N \sum x'^2 - (\sum x')^2 \right] - \left[ N \sum xx' - \sum x \sum x' \right]^2 \right\}^{1/2}$$

$$\epsilon_{rms} = \frac{1}{N} \left( \sum x^2 \sum x'^2 - (\sum xx')^2 \right)^{1/2}; \quad \bar{x} = \bar{x}' = 0$$

$N$ : Total number of particles

$$\beta_x \epsilon_{rms} = \langle x^2 \rangle \quad \alpha_x \epsilon_{rms} = \langle xx' \rangle \quad \gamma_x \epsilon_{rms} = \langle x'^2 \rangle$$

Twiss parameter – for calculating beam transport  
Note: Subscripted are Twiss, not relativistic

# Emittance 3

$$\mathcal{E}_{normalised} = \beta\gamma\mathcal{E}_{geometric}$$

Normalised emittance conserved with acceleration

$$\mathcal{E}_{rms} = \mathcal{E}_{\sigma}$$

Produces an ellipse that extends to +/- 1  $\sigma$ ,  
not all of the beam.

$$\mathcal{E}_{4rms} = 4\mathcal{E}_{rms} = \mathcal{E}_{2\sigma}$$

and yet another definition trap...

# Emittance 4

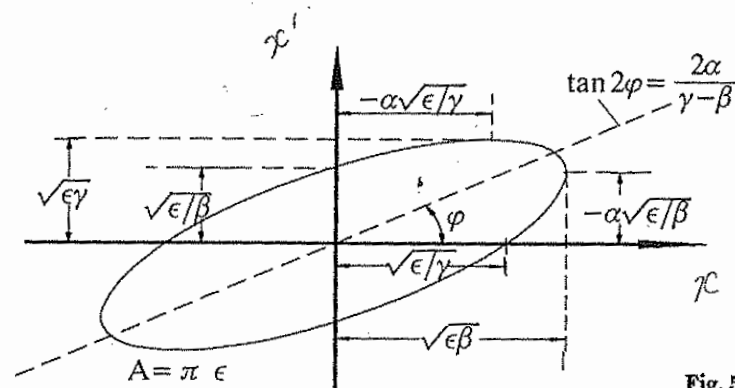

Fig. 5.22. Phase space ellipse

152

$$\gamma x^2 + 2\alpha x x' + \beta x'^2 = \epsilon$$

Emittance ellipse

For plasma sources the ion temperature and source outlet aperture give the minimum emittance.

$$\epsilon_n = \beta \gamma \sigma_{x'} \sigma_x \quad \epsilon_n = \frac{\gamma (\beta m_0 c \sigma_{x'}) \sigma_x}{m_0 c} \quad \epsilon_{th} = r_{out} \sqrt{\frac{2E_{th,ion}}{3m_0 c^2}}$$

Small apertures and low (ion) temperature plasmas are good.

# Brightness

$$B_b = \frac{I_b}{\pi^2 \varepsilon_x \varepsilon_y}$$

- The beam brightness is a measure of the intensity per emittance in both transverse planes.
- Considering all the difference in emittance definition, and almost universal inconsistency in the pre-factor used for calculating brightness means it is rarely quoted as a value.
- It can be used for comparison (e.g. reducing both emittances by 10% increases the brightness by ~20%).

# Material Efficiency

The conversion efficiency from atom to ion:

$$\eta = \frac{N_{ions}}{N_{atoms}}$$

There can be several reasons why efficiency is important:

- The raw material is expensive, e.g.  $^{208}\text{Pb}$   $\sim$  1k\$/gramme,  $^{130}\text{Xe}$   $\sim$  7k\$/litre
- The atoms are limited (e.g. radioactive atoms from a target).
- The raw material is dangerous or polluting (e.g. U).

# Beam Purity

For some applications, the minimization of beam impurities is very important e.g.:

- Medical applications.
- Experiments requiring high purity beams to reduce background.

$$\kappa = \frac{N_{ions}}{N_{beam}}$$

Some source types can already minimize contamination, e.g. selective ionization with lasers.

The beam purity requirements may not be possibly using the source alone.

It can be further improved by using:

- Electro-static and magnetic spectrometers (and combined in Wein filters)
- RF acceleration (will only accept a narrow band of A/q values)
- Stripper foils producing charge states out of reach of contaminants e.g. suppression of  $^{17}\text{O}$  from  $^{17}\text{F}$  by stripping to  $^{17}\text{O}^{8+}$  and  $^{17}\text{F}^{7+}$  .  
Or breaking up contaminant molecules ( $\text{H}_2^+$  background on  $\text{D}^+$ )



# Operating Pressure

Pressure inside ion sources can vary dramatically depending on the type.

CERN's REX EBIS operates at  $10^{-10}$  mbar (to avoid contamination of rest gas ions over the radioactive beam, and reduces charge exchange with highly charged ions).

High intensity single charged ion sources can run up to 1mbar.

High pressures in the source can lead to high pressures in the beam transfer:

- > Recombination or stripping losses.
- > Breakdowns in extraction system and other accelerating fields.

# High Charge States – Ionization Potential

High charge states can also be produced from ion sources.

They require sufficient electron energy for ionization & sufficient time to be bred.

Ionization potentials have been calculated for all states of all elements:

Carlson, Nestor, Wasserman and McDowell,

[http://dx.doi.org/10.1016/S0092-640X\(70\)80005-5](http://dx.doi.org/10.1016/S0092-640X(70)80005-5)

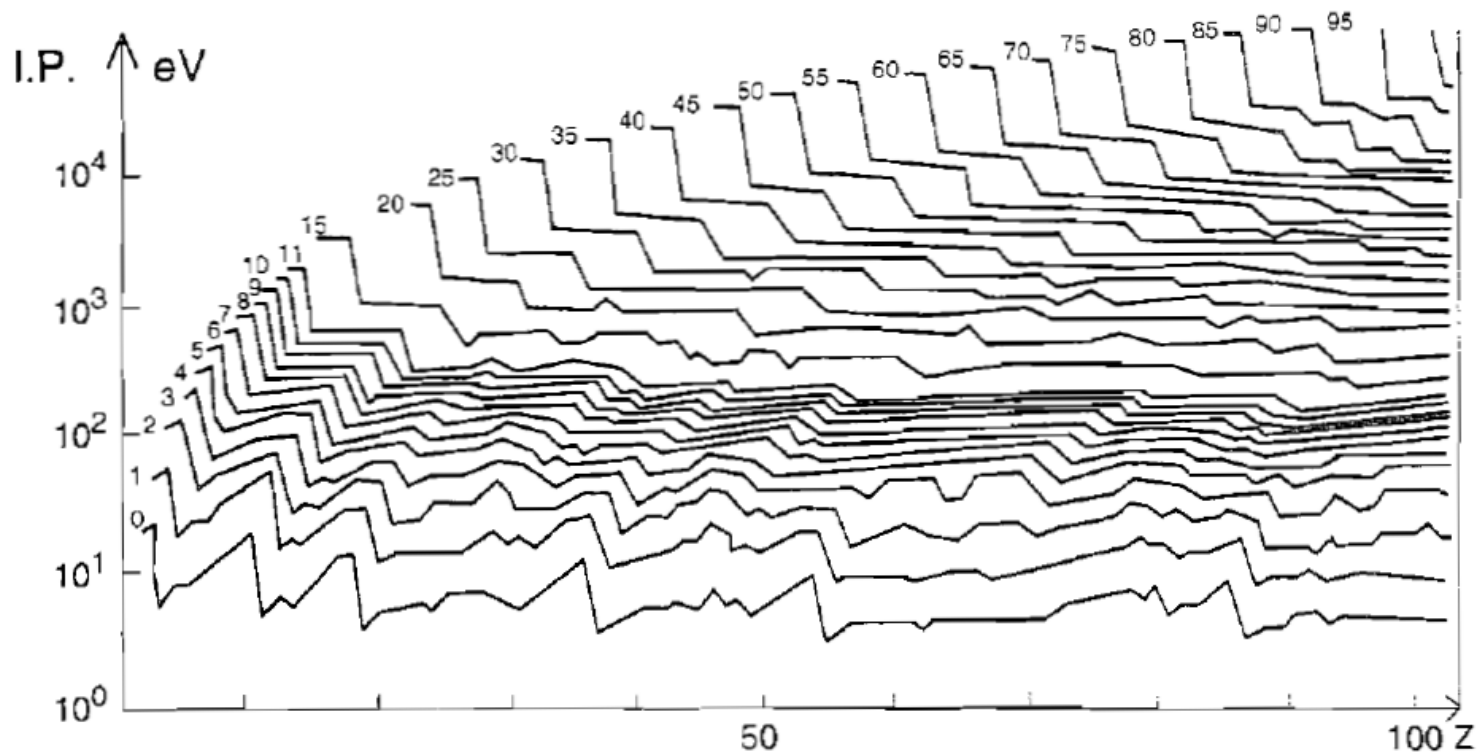

# High Charge States – Confinement Time

For highly charged ion creation through electron impact ionization, the ions need to be confined for a sufficient time to undergo enough collisions to reach the required charge state.

$$\text{confinement time} = n_e \tau_{ion}$$

High electron density and/or long confinement time.

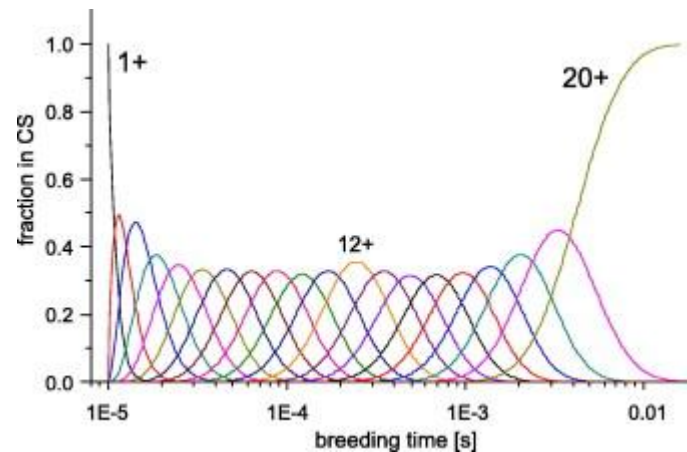

Charge state evolution for  $\text{Ti}^+$ -ions in an EBIT with a current density of  $10^4 \text{ A/cm}^2$  and an electron energy of 5 keV.

# Reliability 1

Any stop of the beam can possibly be an issue, depending on the application.

- A day without beam to the LHC is frustrating.
- But cancelling a cancer patients treatment is worse.

Faults generally fall into the following classes:

- Intermittent – beam performance changes “dramatically” but returns without intervention. (Seconds of downtime).
- Source sub-systems switch off due to interlocks/protection circuits, requiring a resetting. (Minutes of downtime).
- Sub system breaks outside the vacuum, not affecting the vacuum or thermal stability. (Minutes to hours).
- Sub system inside the vacuum, or heating system fails (hours).

The reliability can be characterized by:

Uptime / Availability

Mean time between failures (MTBF)

Mean Time To Repair (MTTR)

# Reliability 2

In many cases the ion sources are an important contributor to the overall reliability of the installation

- or more bluntly: the source is often a big cause of downtime.

Improving source reliability is often a pre-occupation of the source engineer.

All sorts of improvements can be made:

- Improving EMI sensitivity to avoid trips due to breakdowns.
- Using UPS to reduce sensitivity to power cuts.
- Keeping installations clean (inside and out).
- Keeping spares – maintaining and testing them.
- Cold-spare sources (fully built, tested and ready for installation).
- Hot-spare sources (2 installed sources, with a switch-yard).

# Stability

Variation in the beam performance, affecting any of the beams specification parameters can be a problem.

Are some characteristics more critical than others for the user?

Improvements can be made by (for example):

- Adding feedback loops on critical parameters.
- Over-specifying (not running equipment at the maximum).

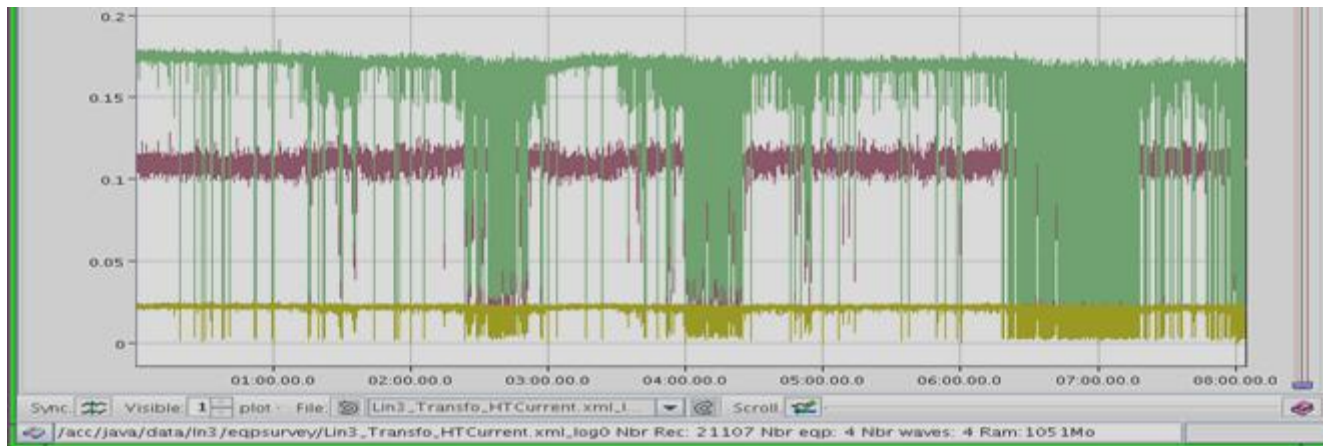

The CERN Linac3 ion source, average beam current per pulse over a period of 8hrs.

Beam peak intensity changes, and many periods of intensity jumping can be seen (from 2009 – now much more stable).

# Space

Constraints on the available space for a source can strongly influence the design.

Examples:

- Internal sources in cyclotrons.
- Compact target ion sources (RIBS facilities)

There is often a big difference between the paper concept of a source...

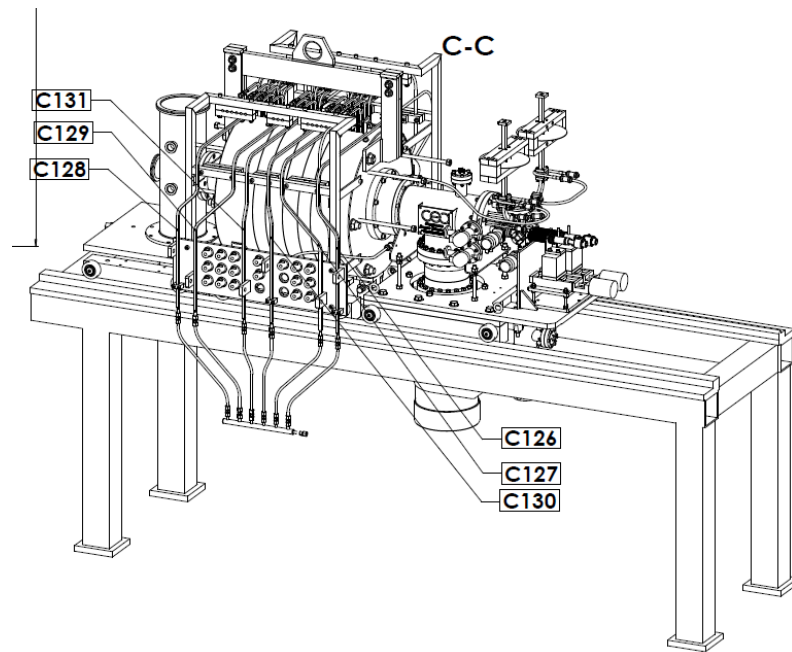

... and its implementation

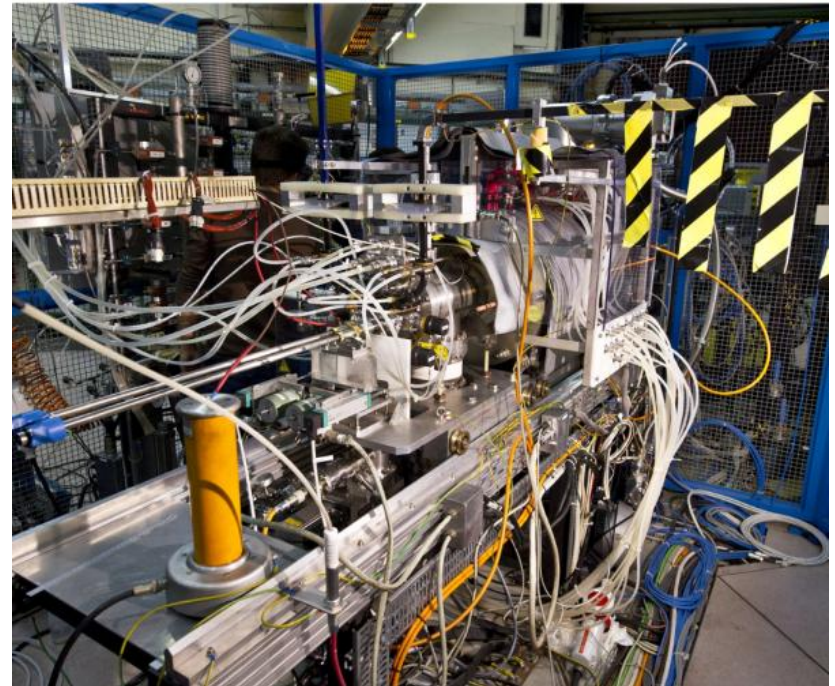

# Material Choices

Sources usually employ a wide range of materials in their construction.

A whole range of material properties are used for Ion Source Engineering:

- Electrical Insulators and Conductors.
- Thermal Conductivity.
- Magnetic properties.
- Melting and boiling points.
- Thermal expansion.
- Mechanical strength, embrittlement, creep.
- Secondary electron yield.
- Work function (affects electron emission)
- Thermal Emissivity.
- Sputtering rate.
- Ease of construction – welding – brazing – surface finish.



# Negative ions – Why?

- Negative ions are (generally) much harder to produce than positive ions.
- Their benefits for the following accelerator are:
  - They have the opposite charge (so are oppositely affected by E and V fields).
  - They are easily stripped to positive ions or neutrals (normally at higher energies).

## Tandem

- Negative accelerated to foil, positive ion back to ground.

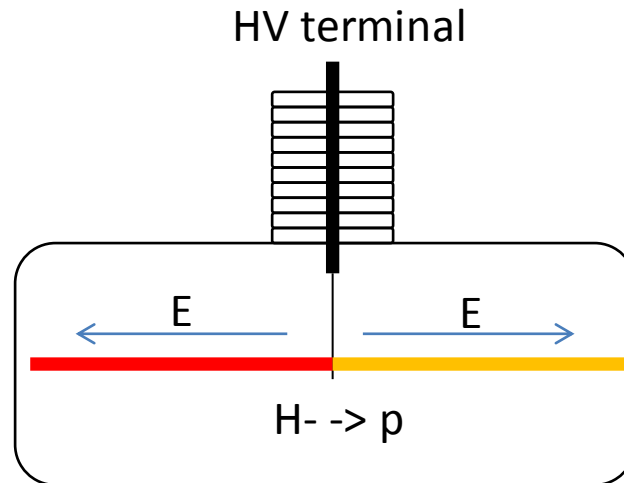

# Negative ions – Why?

Extraction (from cyclotrons)

- Change the charge in a foil, and the positive ion extracts itself

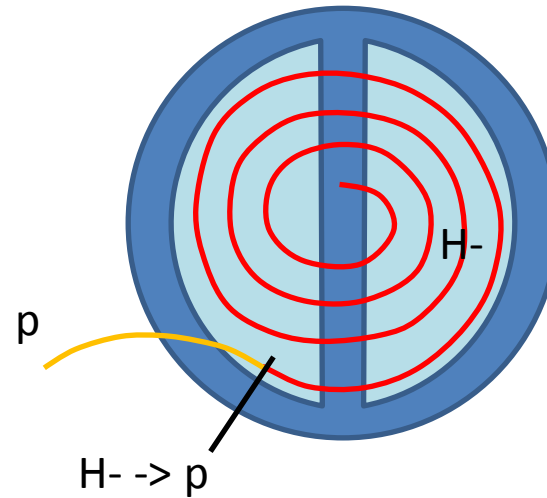

Charge exchange injection (to synchrotron).

- Overlap the negative and (circulating) positive ions – strip to positive – overcome Louiville!

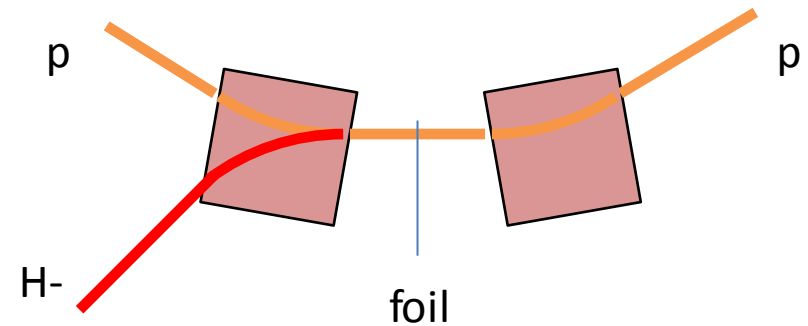

High Energy Neutral Beams (Magnetic Confinement Fusion)

- Efficient stripping to neutrals – to inject through a magnetic field.

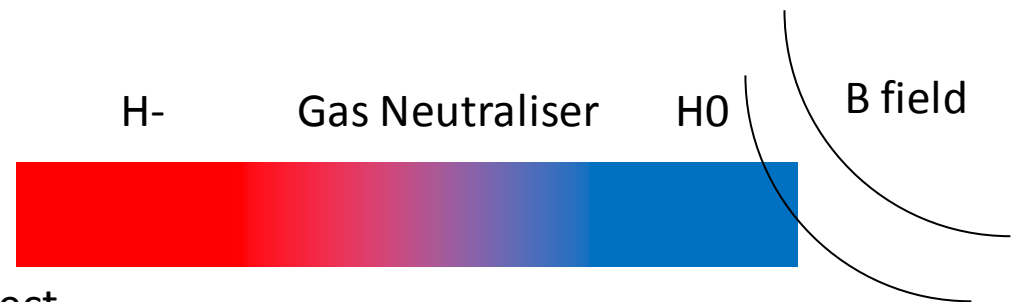

# Charged Particle and Plasma Basics

Start with a few basic concepts for motion of charged particles in a plasma, that will help to understand how sources are working :

- Charged particles in a magnetic field
- $E$  cross  $B$  drift
- Collisional Drift
- Magnetic Mirror

# Plasma Particle Motion

$$\vec{v} \times \vec{B} = v.B.\cos\theta.\vec{n}$$

$$\vec{F} = qe(\vec{E} + \vec{v} \times \vec{B})$$

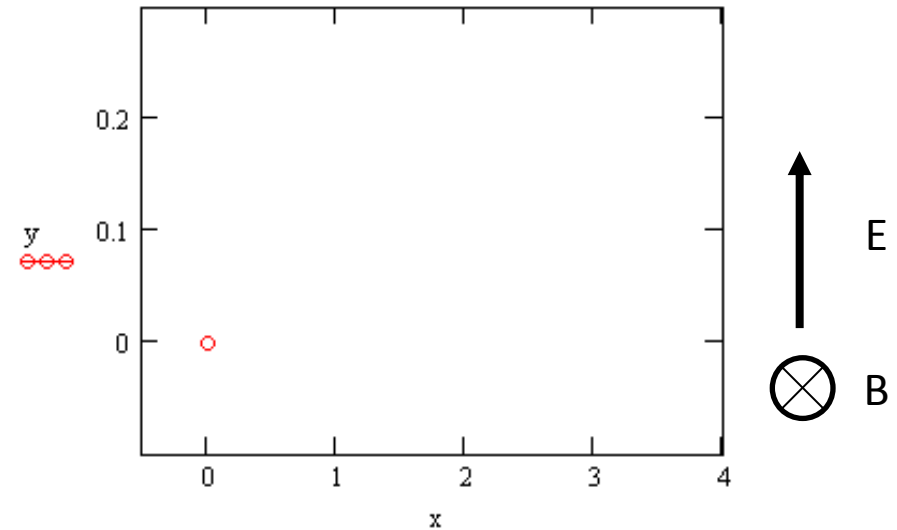
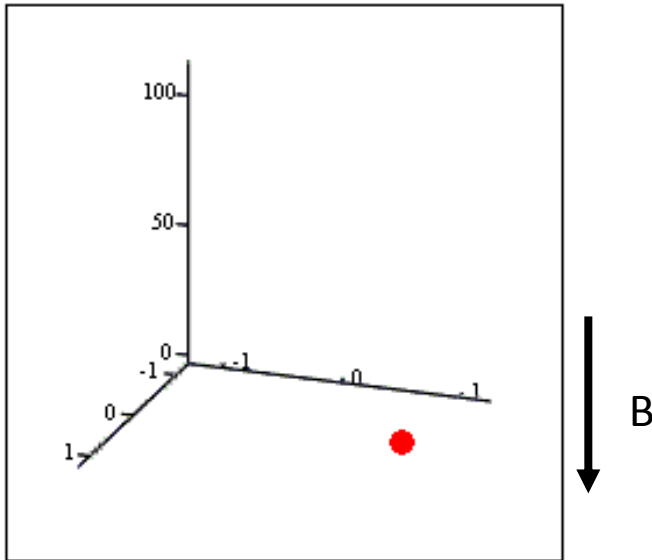

$$\rho_L = \frac{\sqrt{2mE_{\perp}}}{qeB}, \omega_L = \frac{qeB}{m}$$

$$v_{drift} = \frac{\vec{E} \times \vec{B}}{B^2}$$

# Collisional Drift

$$D \sim \rho_L^2 v_c \sim \left( \frac{\sqrt{2m_p E_\perp}}{eB} \right)^2 \frac{1}{T^{3/2}} \left( \frac{m_e}{m_p} \right)^{1/2} \sim \frac{m_p^{1/2}}{T^{1/2}}$$

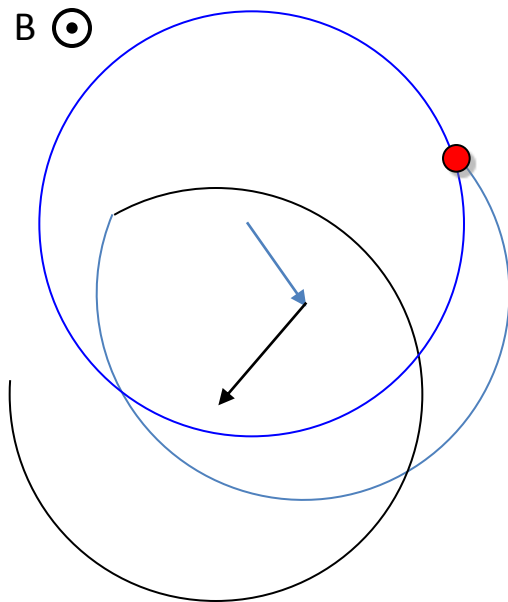

cf: opposite to classical  
energy – velocity equation !

$$v = \left( \frac{2E}{m} \right)^{1/2}$$

# Magnetic Mirror

A force acts in the opposite direction to the  
Increasing B field

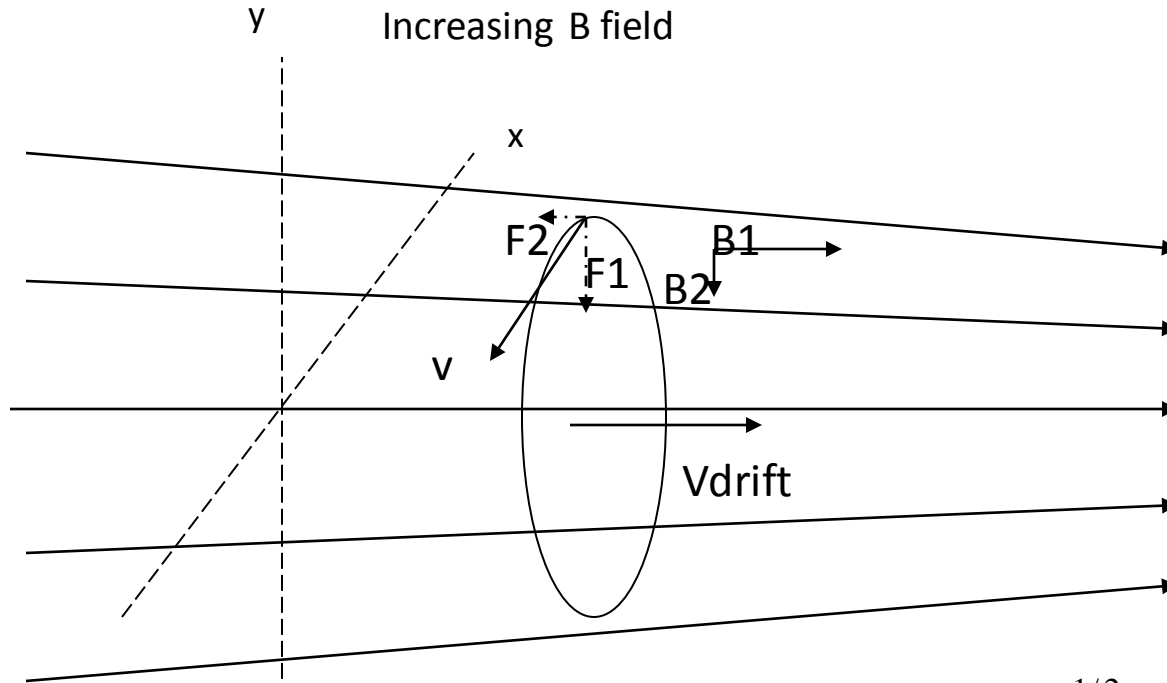

Energy is transferred  
from  $v_{drift}$  to  $v_{\perp}$

$$v_{drift} = \left\{ \frac{2}{m} (K - \mu B) \right\}^{1/2}$$

$$\mu = \frac{mv_{\perp}^2}{2B}$$

$\mu$  = magnetic moment  
K = total kinetic energy

# What's Next...

- We have seen some of the parameters we have to think about for an ion source.
- In the next lecture we will overview the types of source that exist

# Symbols

B: Magnetic field  
 $B_b$ : Beam Brightness  
d: A distance (gap for example)  
D: Diffusion velocity  
e: Electron charge  
E: Electric field  
J: Current Density  
 $J_{CL}$ : Child Langmuir Current Density  
k: Boltzman constant  
m: Mass  
N : Number of particles  
q: Charge State (1..2..3)  
x : Position  
 $x'$  : Angle – px/pz  
T: Temperature  
 $U_d$ : Voltage applied  
V: Voltage used to accelerate a charge

$\alpha_x$  : Twiss alpha  
 $\beta_x$  : Twiss beta  
 $\beta$  : relativistic beta  
 $\gamma_x$  : Twiss gamma  
 $\gamma$  : relativistic gamma  
 $\varepsilon$ : Emittance (geometric)  
 $\varepsilon_{rms}$  : Emittance (geometric , rms)  
  
 $\varepsilon_{4rms}$  :  $4 \times \varepsilon_{rms}$   
 $\nu_c$ : Collision frequency  
 $\rho$ : Bending radius  
 $\rho_L$ : Larmor/cyclotron radius  
 $\omega_L$ : Larmor/cyclotron frequency