

CERN ACCELERATOR SCHOOL 2012:

TECHNICAL ASPECTS: MAGNETIC SYSTEM DESIGN

Thomas Thuillier
LPSC,
53 rue des Martyrs
38026 Grenoble cedex
France
E-mail: thuillier@lpsc.in2p3.fr



OUTLINE

- **Basics of Magnetostatic**
- **Permanent Magnets**
- **Room Temperature Coils**
- **Superconducting Coils**

Biot - Savard Law

- An electrical current flow I in a wire of length $d\vec{l}$ generates an elementary magnetic field $d\vec{B}$ at point M :

- $$d\vec{B}(M) = \frac{\mu_0 I}{4\pi} \frac{d\vec{l}(P) \times \overrightarrow{PM}}{PM^3}$$

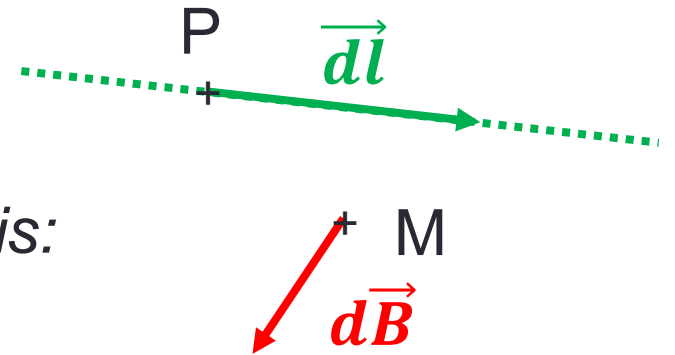

- For an arbitrary curve C , the magnetic Field is:

- $$\vec{B}(M) = \frac{\mu_0 I}{4\pi} \int_C \frac{d\vec{l}(P) \times \overrightarrow{PM}}{PM^3}$$

- where point P follows C and $d\vec{l}(P)$ is the local tangent to the curve C

- For a Volumic conductor V , we define a volumic current density \vec{J} :

- $$\vec{B}(M) = \iiint_V \frac{\mu_0}{4\pi} \frac{\vec{J} dV \times \overrightarrow{PM}}{PM^3}$$

Magnetic Field Generated by a wire

- For a finite wire:

$$\vec{B}(M) = \frac{\mu_0 I}{4\pi d} (\sin \alpha_2 - \sin \alpha_1) \vec{u}_\theta$$

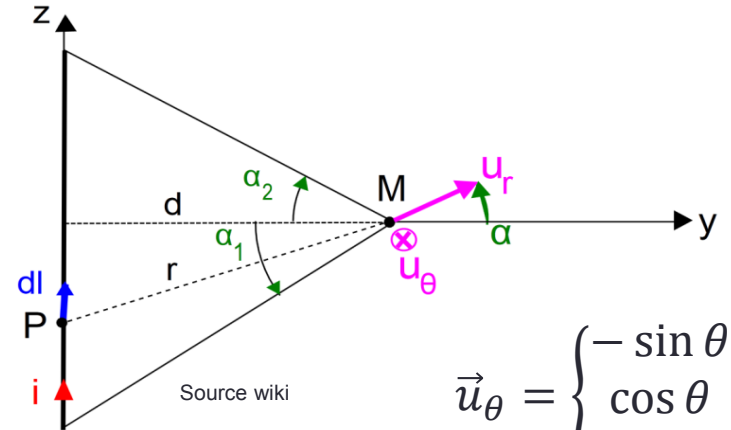

$$\vec{u}_\theta = \begin{cases} -\sin \theta \\ \cos \theta \\ 0 \end{cases}$$

- For an Infinite wire:

$$\vec{B}(M) = \frac{\mu_0 I}{2\pi d} \vec{u}_\theta$$

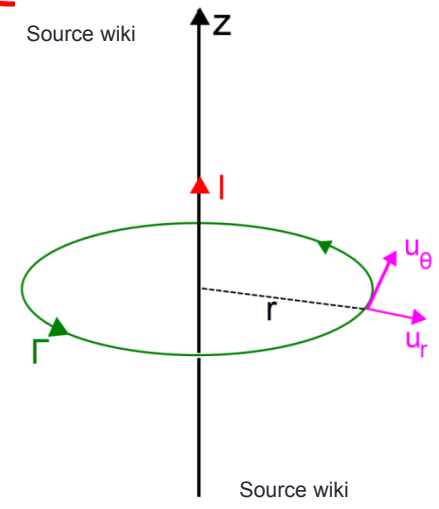
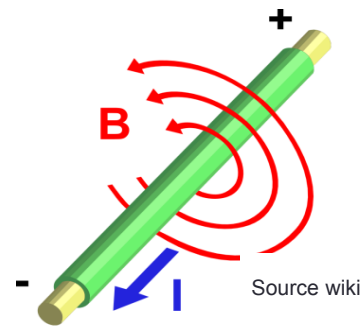

Magnetic Field generated by a single loop

- Magnetic field intensity on the loop axis:

$$\vec{B}(M) = \frac{\mu_0 I}{2R} \sin^3 \alpha \vec{Z} = \frac{\mu_0 I}{2R} \frac{1}{\left(1 + \left(\frac{z}{R}\right)^2\right)^{3/2}} \vec{Z}$$

$$\bullet B(O) = \frac{\mu_0 I}{2R}$$

$$\bullet B(z_{1/2}) = \frac{B(O)}{2} \rightarrow 2z_{1/2} \sim 1.53R$$

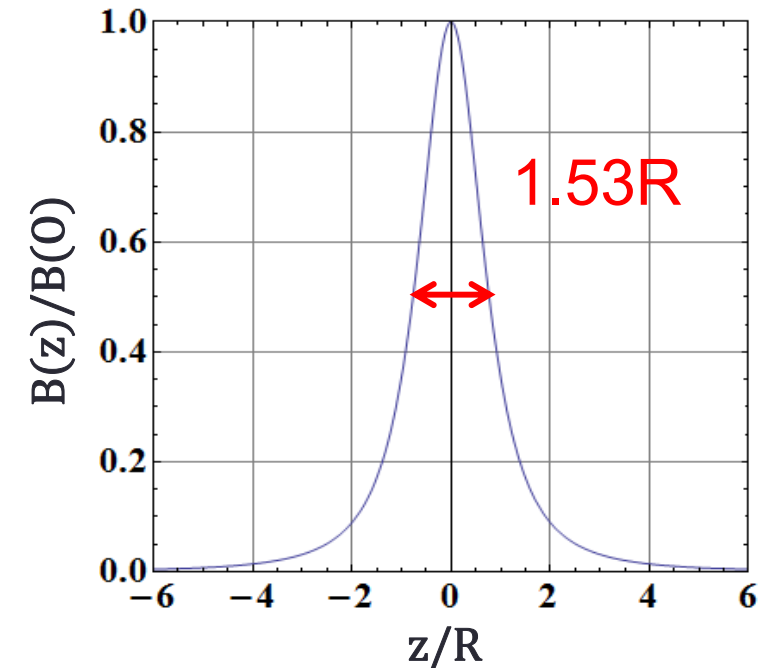
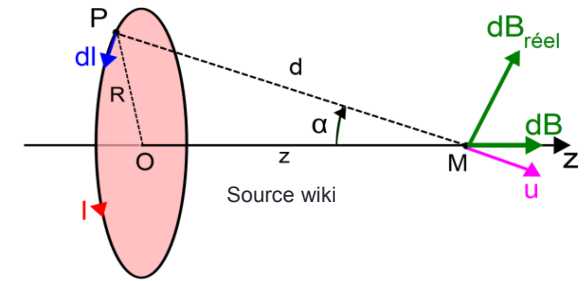
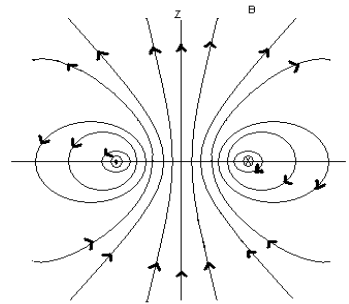

- Magnetic Field out of the axis: non trivial formula

Magnetic Field Generated by a flat solenoid

- Consider an axial Coil with N turns covering $2a$ along Z
- Total loop current in the coil is defined by the **Ampere.turns= $N \times I$**

- $B(z) = \frac{\mu_0 NI}{2R} (\cos \alpha_2 - \cos \alpha_1) \vec{z}$

- Field Intensity at the Coil center

- $B(0) = \frac{\mu_0 NI}{2R} \frac{1}{\sqrt{1+(a/R)^2}}$

- Inductance

- $L = \mu_0 N^2 \frac{\pi R^2}{2a}$

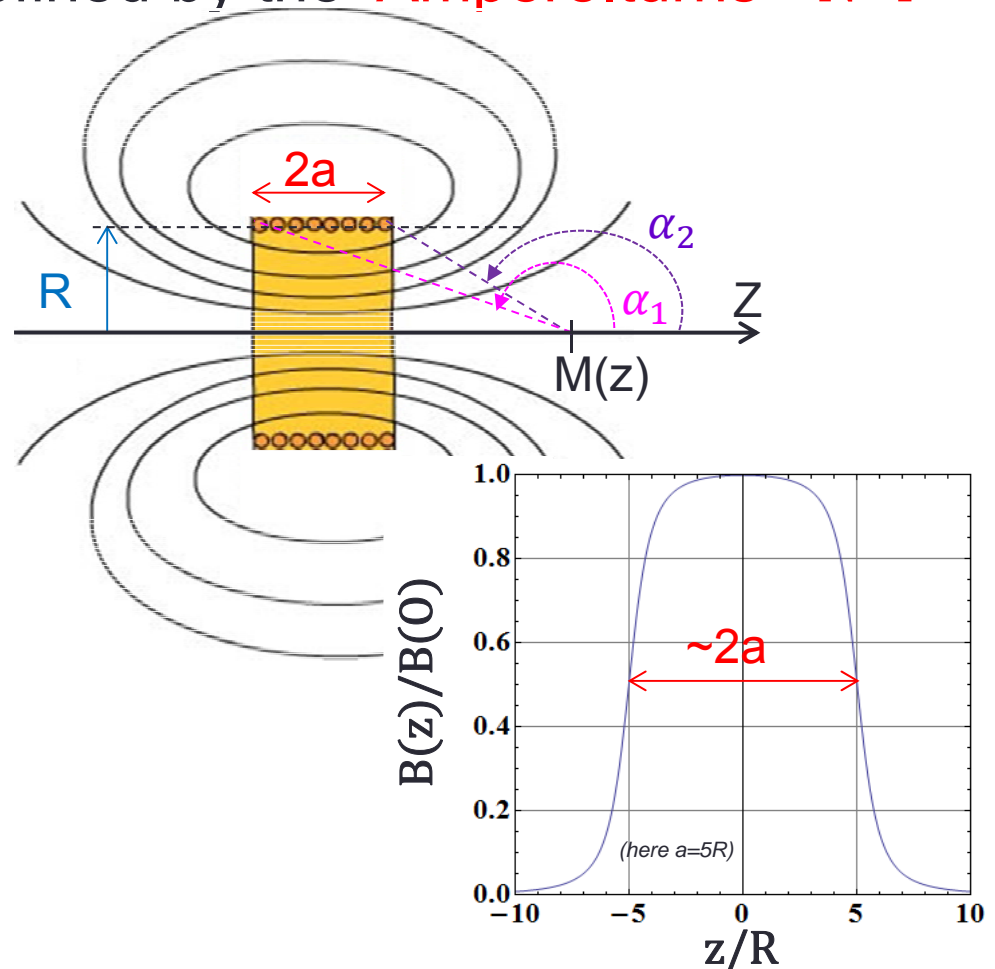

Magnetic Field Generated by a Thick Coil

- A rough analytical estimate of $B(0)$:
 - $B(0) = \frac{\mu_0 NI}{2\langle R \rangle} \frac{1}{\sqrt{1+(a/\langle R \rangle)^2}}$
 - $N=N_z \times N_R$
 - $\langle R \rangle = (R_1 + R_2)/2$
- Real Field should be studied by simulation
 - 2D FreeWare: Poisson Superfish, FEMM...

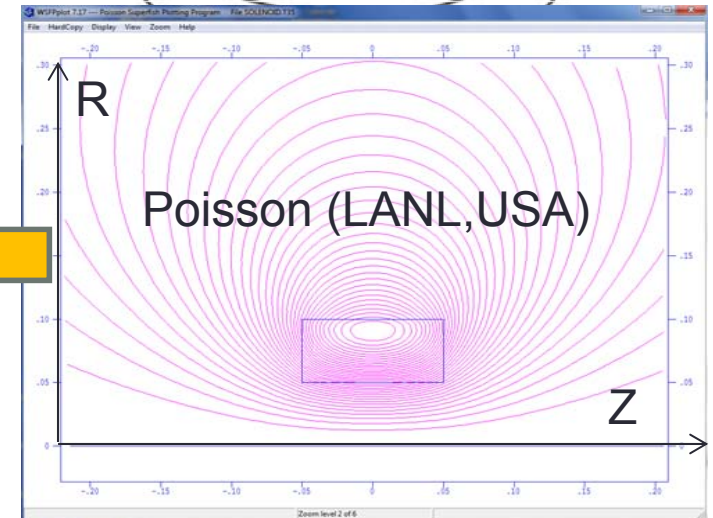
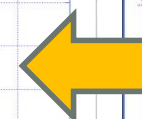
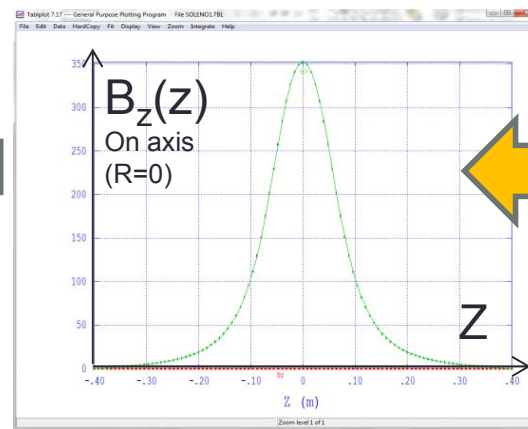
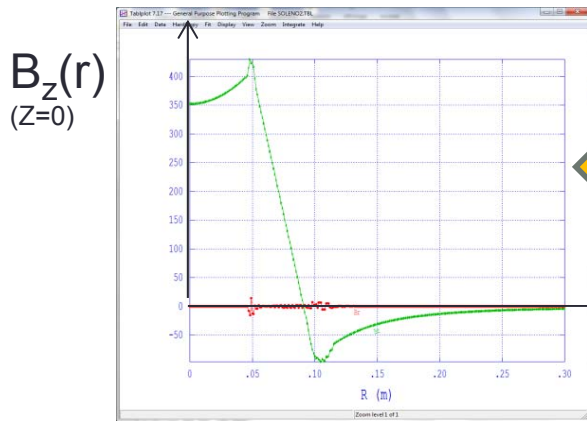
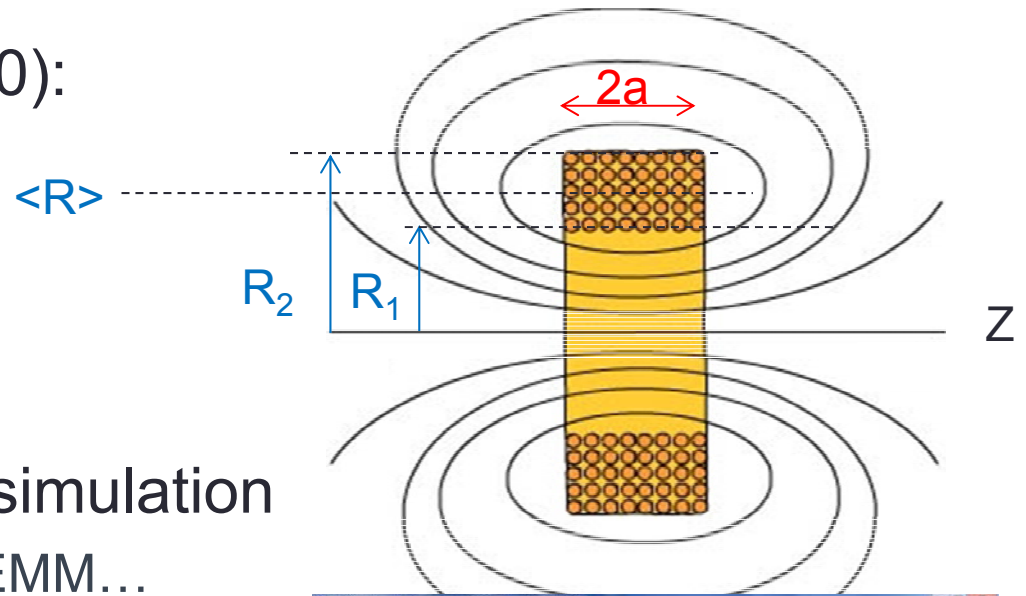

Forces on Coil

- Any magnetic Field B acting on a wire crossed by a volumic current generates a magnetic Force:

- $$F = \int J \vec{dl} \times \vec{B} dV$$

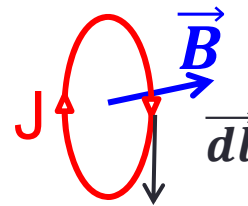

- The force is exerted locally and globally
- Usually, the wire coil is epoxy impregnated to hold these forces AND isolate the coil turn one from each other
- When several coils are set together to build a complicated system, each coil may suffer a global non null net force and torque
- Forces must be computed at the time of conception to carefully choose the material able to hold this force field

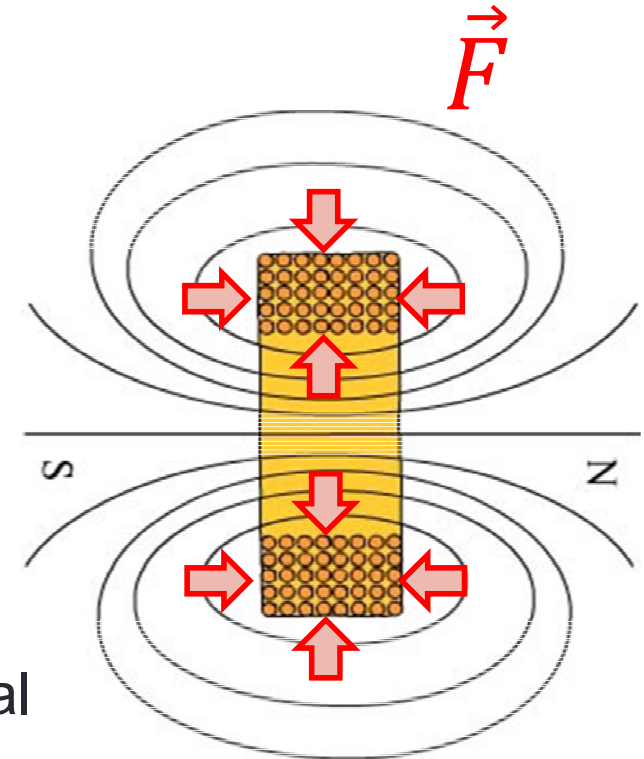

Magnetic Properties of Materials: Permeability μ

- Magnetic permeability μ
 - μ Depicts the way a material acts in presence of an externally applied auxilliary magnetic Field H
 - B is the resulting magnetic field intensity inside the material
 - $B = \mu H = \mu_0 \mu_r H$
 - $\mu_0 = 4\pi \times 10^{-7} \frac{\text{Henry}}{\text{m}}$ is the permeability of vacuum ($B = \mu_0 H$ in vacuum)
 - $\mu_r = \frac{\mu}{\mu_0}$ is the relative permeability of a material
- The magnetic property of a material is defined by its internal magnetization M :
 - $B = \mu H = \mu_0 \mu_r H = \mu_0 (H + M)$
 - $M = \frac{\mu - \mu_0}{\mu_0} H = (\mu_r - 1)H$
- Magnetic Susceptibility: X_m
 - $X_m = \mu_r - 1 \rightarrow M = X_m H$
- The magnetization **M** modifies the local magnetic field H intensity outside the material

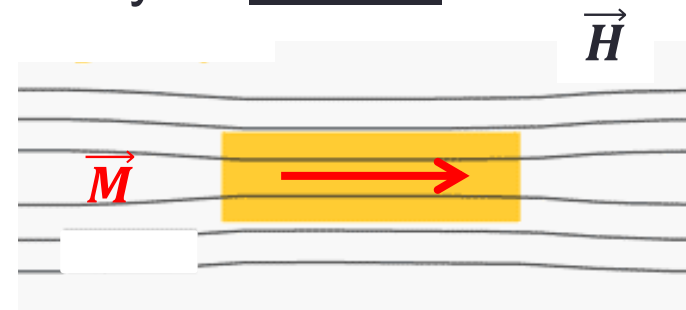

Microscopic origin of magnetism

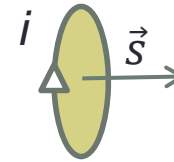

- The Ampère Model

- A magnetic material can be modeled by a set of microscopic individual dipolar magnetic moments $\vec{\mu} = i\vec{S}$ generated by electron circulation around atoms
 - i current in the loop
 - \vec{S} oriented area of the loop
- Each individual current loop generates an infinitesimal magnetic field B
- A global magnetization of a material appears if the elementary magnetic dipole moments are aligned in the same direction

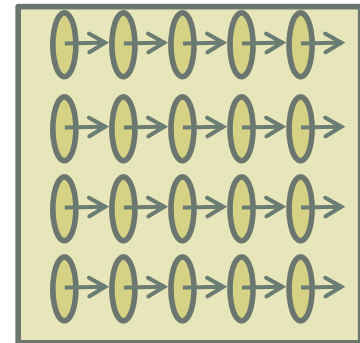

Material with all Individual magnetic moments aligned
=> High magnetization

Diamagnetism - Paramagnetism

- $B = \mu_0 \mu_r H = \mu_0 (H + M)$
- $M = X_m H$

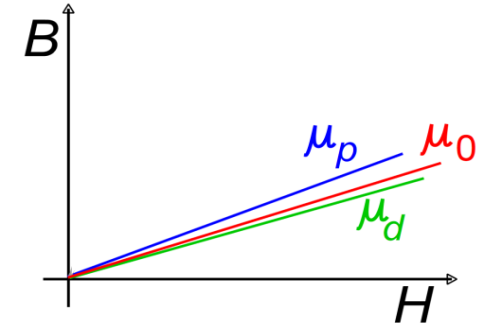

- **Diamagnetism:** the material tends to expell the field lines $\rightarrow X_m < 0$

- M is opposed to H
- The local magnetic field is increased out of the material
- Water, earth, Cu, Hg, Au, Bi...
($|X_m| \ll 1$)
- Superconductors: $X_m = -1!!!$

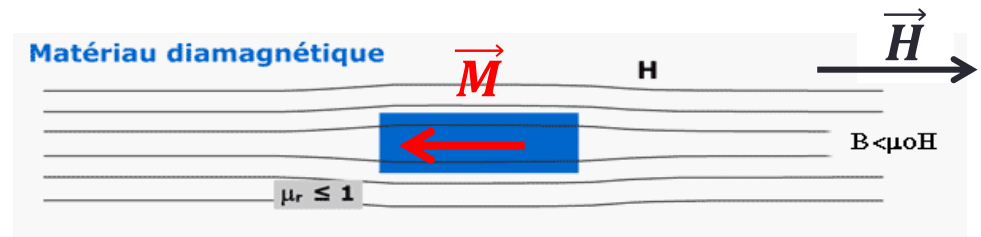

- **Paramagnetism:** the material sucks up the field lines $\rightarrow X_m > 0$

- M in the same direction as H
- Au, Cs, W, Mg... ($X_m \ll 1$)
- The resulting magnetic field is increased out of the material

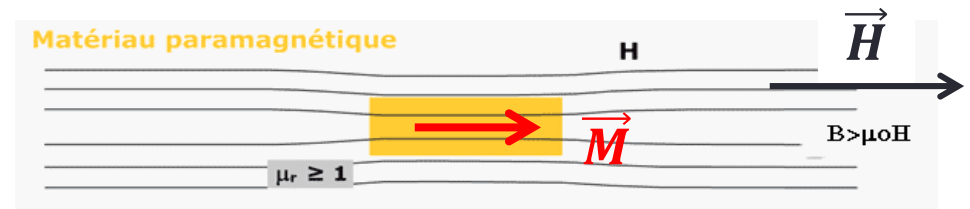

Ferromagnetism

- $B = \mu_0\mu_r H = \mu_0(H + M)$
- $M = X_m H$
- Ferromagnetic materials feature a high capacity to suck up magnetic field lines ($\mu_r \gg 1, so X_m \gg 1$)
- M saturates above a given H
- M is a function of Temperature: $X_m = f(T)$
- Ferromagnetism damps to paramagnetism above the Curie Temperature T_c

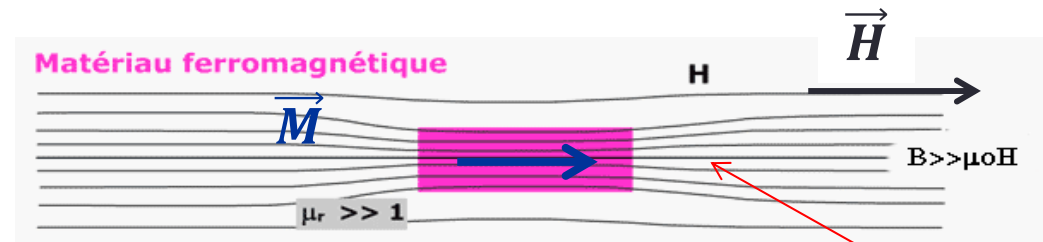

Near to a ferromagnetic Material, B intensity can be highly amplified

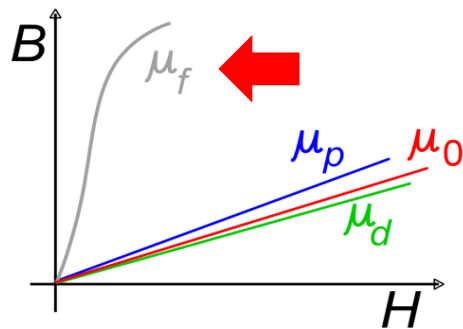

Ferromagnetic Material	μ_r	Curie Temp. °C
Co	250	1 115
Fe	10 000	770
Mu-metal	150 000	420
Ni	600	358

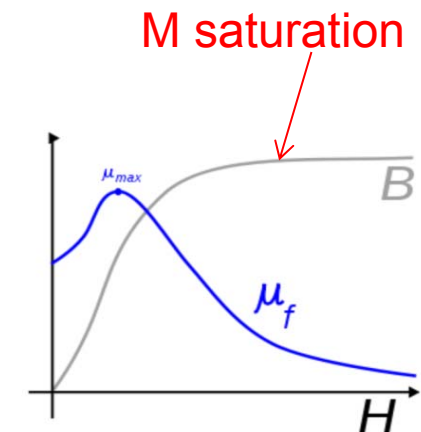

Ferromagnetism

- Hysteresis Curve:
 - A ferromagnetic material keeps the memory of its former magnetization state

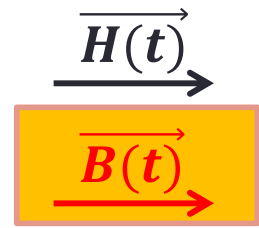

3 Remanence B_r :
When $H \rightarrow 0$, The material keeps a part of its magnetization: **the Remanent field B_r**

2 Saturation of magnetization:
Above $H > H_s$, the magnetization saturates to B_s

4 Coercivity H_c :
The absolute value of $H < 0$ for which the magnetization $B \rightarrow 0$ from the magnetization saturation

1 First magnetization curve:
If $B=0$ prior to applying H , the material magnetizes following the curve A

5 Magnetization reversal:
When $H < -H_c$, the elementary spins of material orientates toward the new H opposite direction and magnet saturates to $-B_s$

6. And so on...

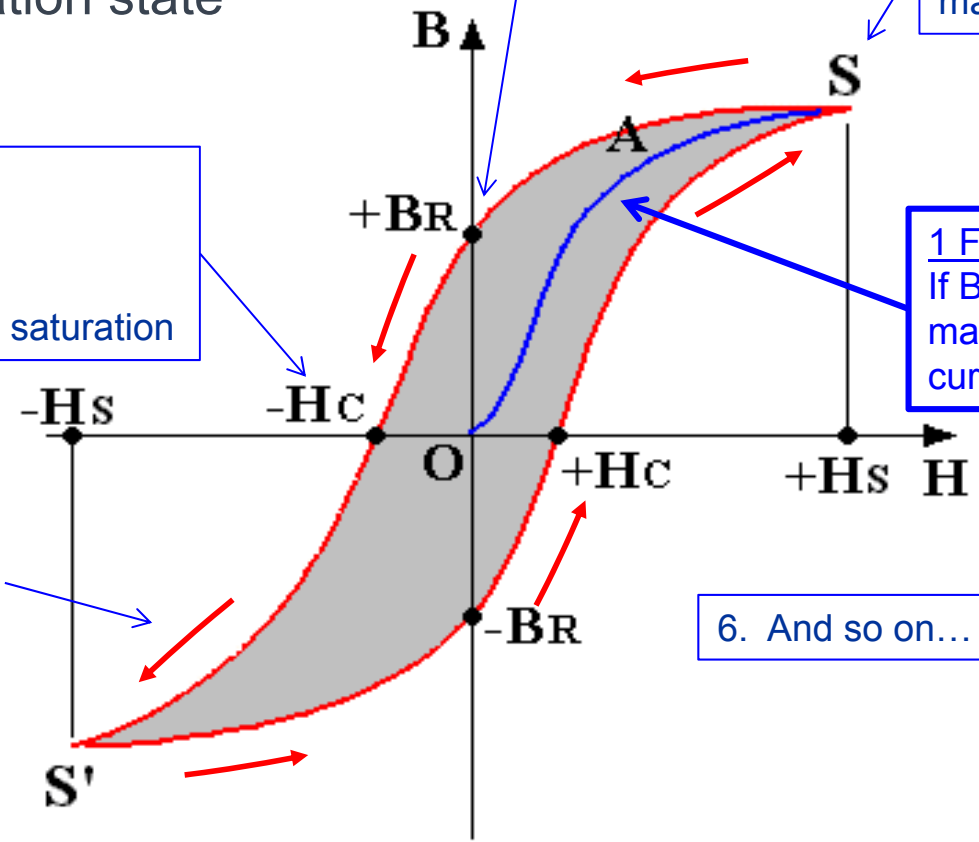

Permanent Magnets

- Permanent magnets are ferromagnetic materials with High Coercivity and High Magnetization values along an Easy Axis
 - Easy Magnetization axis is fixed at the time of industrial construction
 - Permanent magnets are anisotropic materials
- $\text{Sm}_2\text{Co}_{17}$ magnets
 - $B_r \sim 0.9-1.1\text{T}$
 - $H_{cJ} \sim 2.5-0.8\text{T}$
 - $T < 200^\circ\text{C}$
- FeNdB magnets
 - $B_r \sim 1.1-1.5\text{T}$
 - $H_{cJ} \sim 3.3-1.1\text{T}$
 - $T \sim 20-60^\circ$ for reliable operation

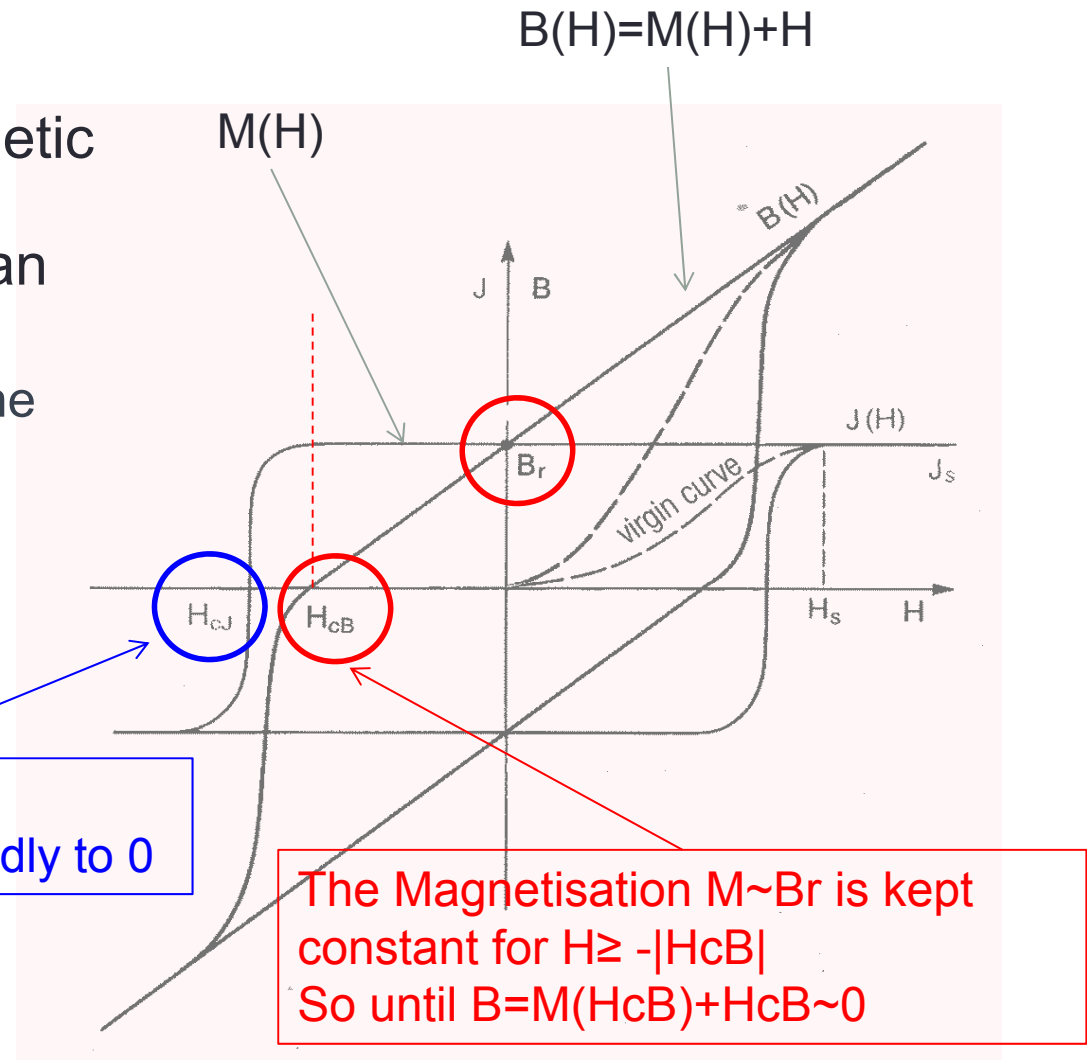

Plot extracted from Vacuumschmelze documentation

Temperature dependance of Permanent Magnets

- The ability of a magnet to keep a high coercivity strongly depends on its temperature
 - The higher the temperature, the higher the thermal vibration in the magnet lattice and the larger the probability that an individual dipolar magnetic moments flips over to the wrong direction.
 - As stated before, ferromagnetism disappears at the Curie Temperature

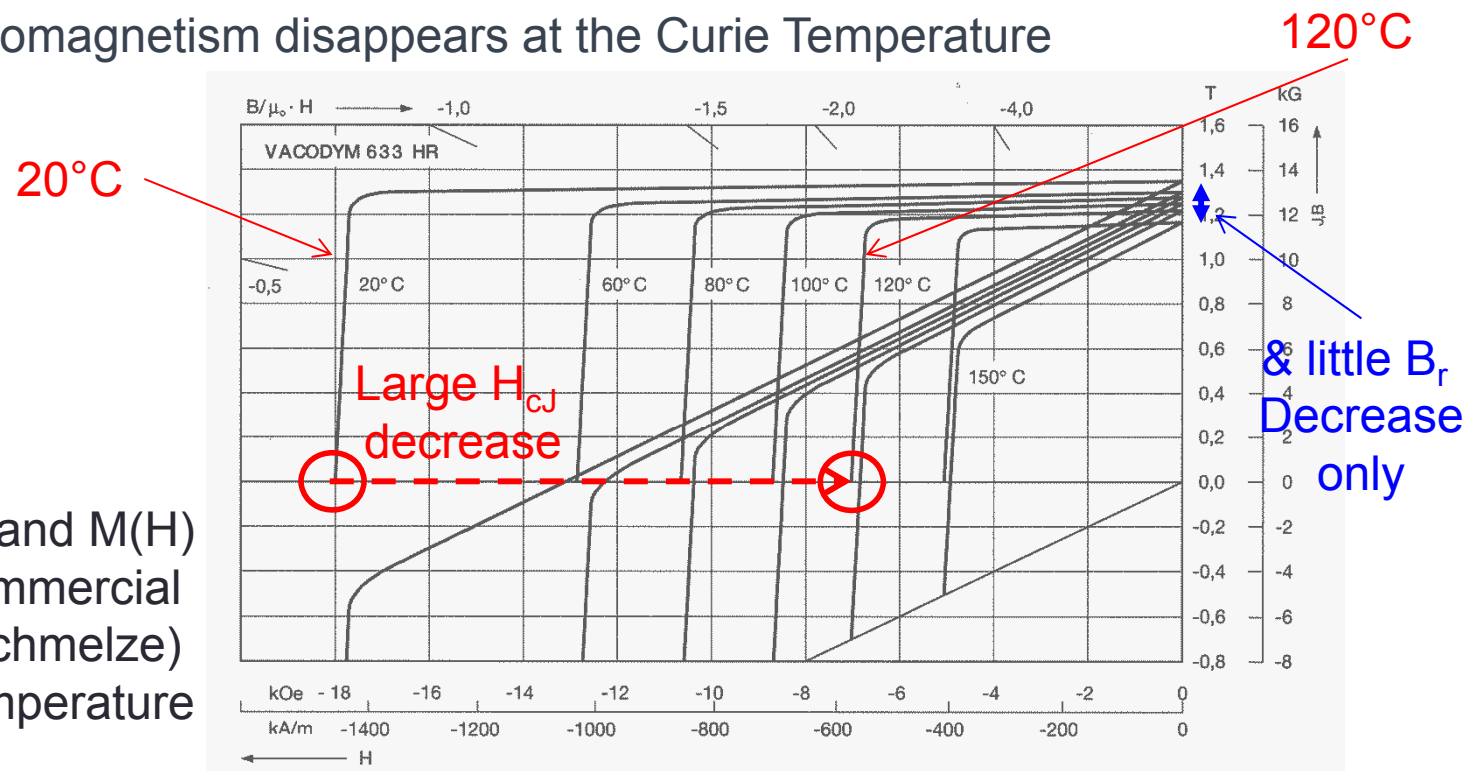

B(H) and M(H)
Evolution of a commercial
FeNdB Magnet (VacuumSchmelze)
As a function of its temperature

Properties of Permanent Magnets at cryogenic temperatures

- Permanent Magnets feature interesting properties at cryogenic temperatures

+10% Remanence at 100-150 K
+15-20% below if FePrB

+300 to +400% Coercivity at 100-150 K

**NO Spin Rotation
Transition Phase
For FePrB**

**Spin Rotation
Transition Phase
For FeNdB**

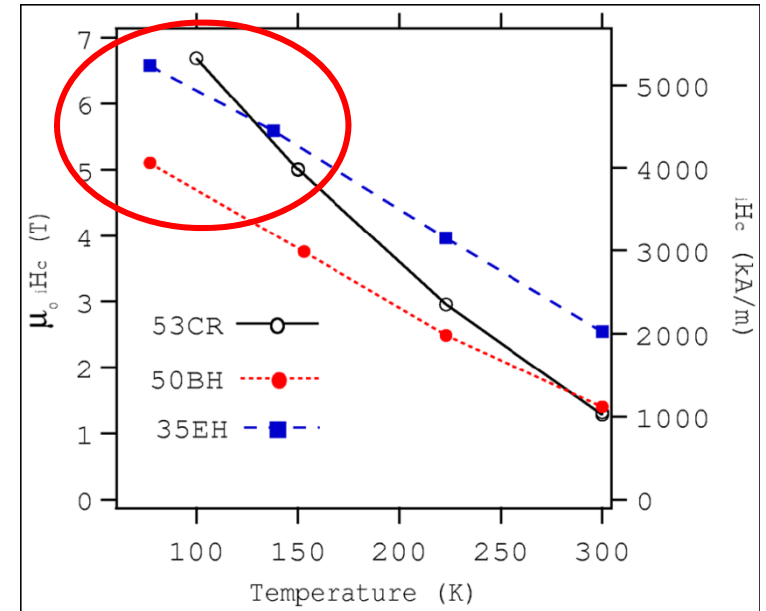
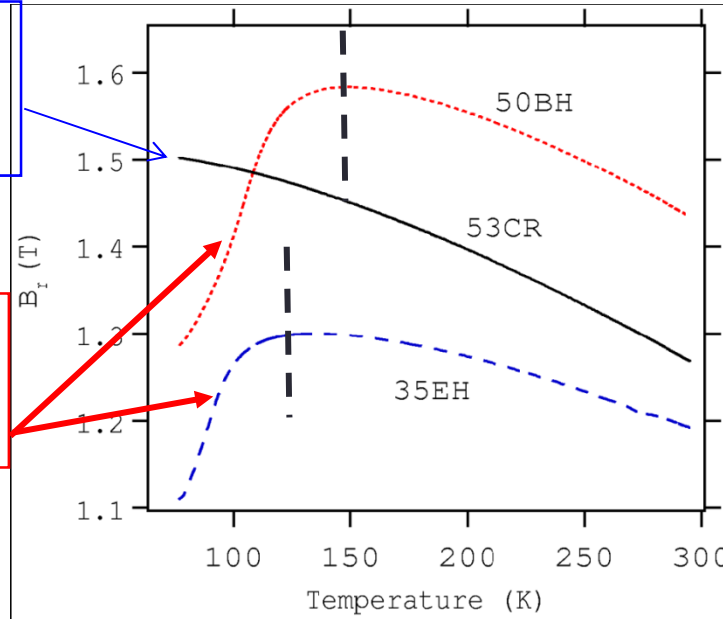

Ref: T. Hara et al., Phys. Rev. ST Accel. Beams 7, 050702 (2004)

- Cryogenic Magnet are used to build intense WIGGLERS in synchrotron facilities
- They can be used to design high magnetic field multipole under high magnetic constraint

Designing a structure with a set of permanent magnets

- The working point of each individual magnet must be carefully checked
 - 3D Magnetic Simulation is necessary to Check the working point of each individual magnet vs T°
 - 3D Freeware: Radia (ESRF, requires Mathematica)
 - 3D © Software: Vector Field, Ansys...

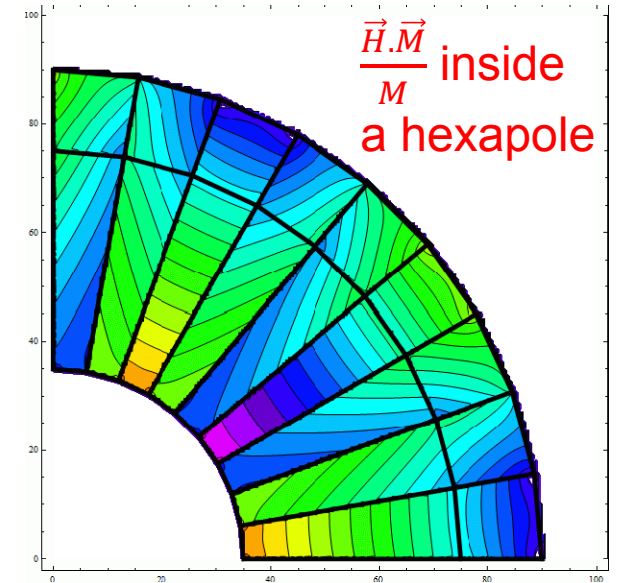
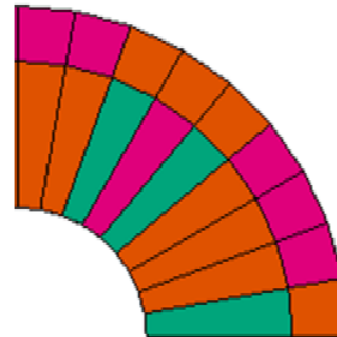

1/4 hexapole simulated with Radia/Mathematica

The magnet 1 generates an auxiliary field H_1 in the surrounding space
 In the magnet 2, $B_2 = M_2 - |H_1|$.
 One must check that $|H_1| < H_{cB}$

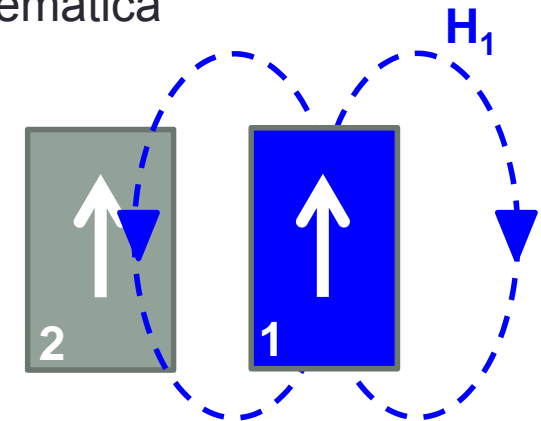

Forces on magnets

- The force acting on a magnetic material volume V is:
 - $\vec{F} = \iiint \vec{J}_m \times \vec{B} dV$
 - J_m is the magnetization current density caused by aligning atomic magnetic dipoles.
 - $\vec{J}_m = \vec{\nabla} \times \vec{M}$
- The global magnetic force for a mixture of electromagnet and ferromagnet is :
 - $\vec{F} = \iiint (\vec{J}_m + \vec{J}) \times \vec{B} dV$
 - J is the electrical current density in an electromagnet
- The force should be computed numerically
 - Poisson 2D, Tosca/Opera 3D, Radia...

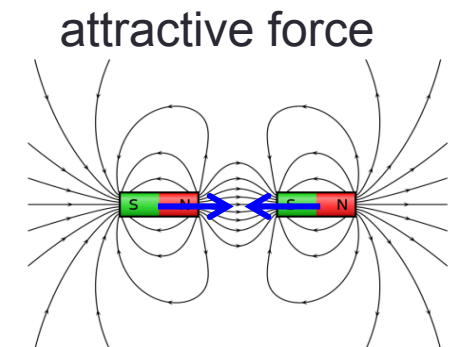
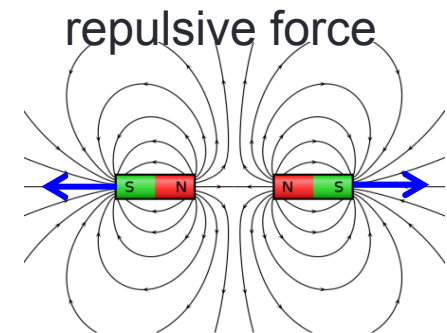

Copper Coil at room temperature

- Three families for three range of magnetic field
 - If $J < 4 \text{ A/mm}^2 \Rightarrow$ no cooling required
 - Eg: magnetic Steerer
 - Right picture: hexapole to correct dipole aberrations
 - Generates field up to $\sim 0.01\text{-}0.02$ Tesla
 - $J \sim 10\text{-}20 \text{ A/mm}^2 \Rightarrow$ water cooling with 2-10 l/min
 - Classical electro-magnet
 - $B \sim 0.1\text{-}1$ Tesla
 - $J \sim 100\text{-}300 \text{ A/mm}^2 \Rightarrow$ high flow watercooling (20-100 l/min)
 - Bitter Coil, polyhelix coil
 - $B \sim 1\text{-}35$ Tesla (!)

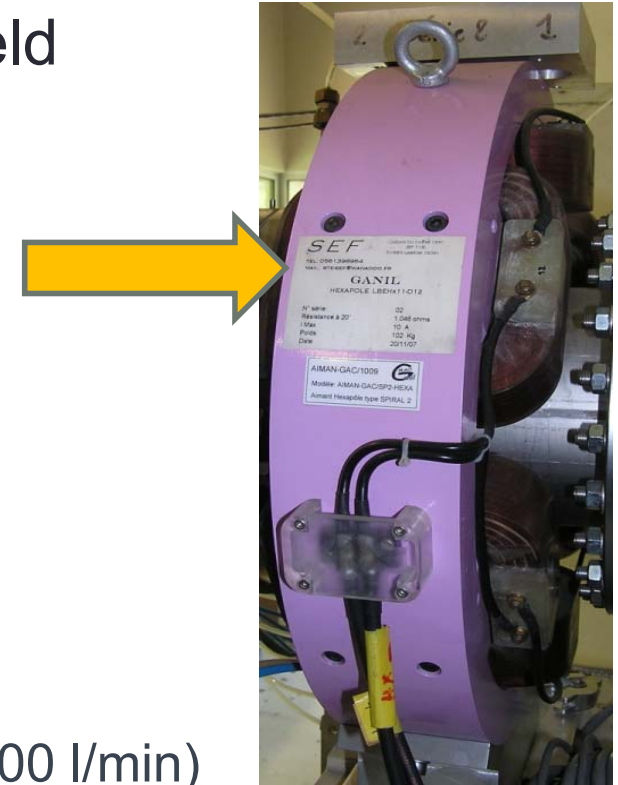

Classical water cooled Copper Coil technology

- $J \sim 10\text{-}20 \text{ A/mm}^2$
- Copper tube with inner cooling water to compensate the Joule Effect
- Epoxy impregnated to insulate and hold electromagnetic forces
- High intensity (200-2000 A)
- Low resistance (1-50 m Ω)
- Small turn number (10-300)
- $B \sim 0.1\text{-}0.5 \text{ T}$ on axis



4 double pancake coil

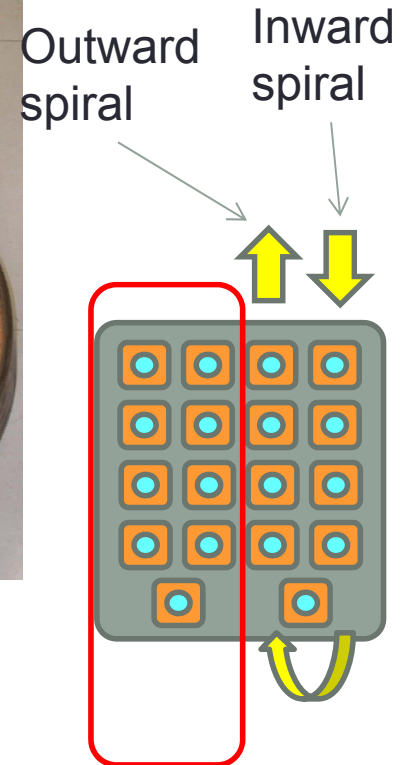

1 double
pancake coil
= 1 copper tube



Passing from inward spiral to outward spiral, keeping same direction of coil rotation

Classical Copper Coil – Electric properties

Electrical engineering:

- Coil Length : $L \sim 2\pi \langle R \rangle \times N_{turn}$ (see slide 7)
- Coil Resistance:
 - $R = \frac{\rho L}{s} \sim 10\text{-}100 \text{ m}\Omega$
 - Copper resistivity $\rho(20^\circ\text{C}) \sim 1.7 \times 10^{-8} \Omega \cdot m$
- Dissipated power (Joule effect):
 - $P = RI^2 \sim 10 - 100 \text{ kW!}$
- Forces on coil to be computed
 - $F \sim 100\text{-}1000 \text{ N}$
- Coil Inductance to be computed from the stored magnetic energy
 - $\frac{1}{2} LI^2 = \frac{1}{2} \iiint \vec{B} \cdot \vec{H} dV$
 - $L \sim 1\text{-}100 \text{ mH}$

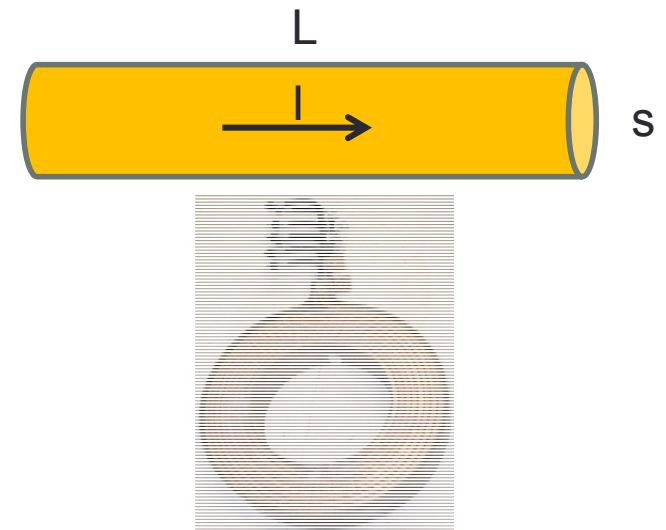

Classical Copper coil – Water flow and pressure drop

- Waterflow engineering

- De-ionized water is mandatory
- Volume Flow rate and Pressure drop in the coil given by the Poiseuille law:

- $Q = \frac{\pi R^4}{8\eta L} \Delta P$

- $Q = \frac{dV}{dt}$ volume flow rate

- η fluid viscosity ($\eta = f(T)$ see table)

- R, L are pipe radius, pipe length

- ΔP pressure drop through the pipe,

- usually fixed by the water pump

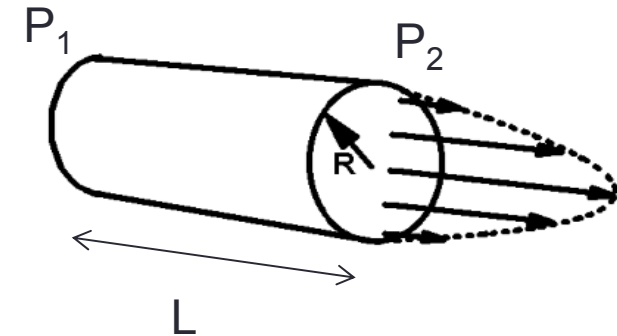

Water temperature (°C)	Water Viscosity (Pa.s)
0	1.8×10^{-3}
20	1.0×10^{-3}
50	0.55×10^{-3}
100	0.28×10^{-3}

Heat Exchange in a water cooled copper coil

- Water is an excellent cooler
- The heat exchange balance in the coil is performed by forced convection:

- $W = hS\Delta T$ power dissipated in the fluid

- S surface of exchange $S = L \times p = L \times 2\pi R$
- ΔT elevation of temperature in the coil
- h mean coefficient of heat exchange $W/m^2/^\circ C$
- $h \sim 5000$ for liquid water
- h can be calculated from engineering tables

- A well balanced water cooled copper coils features a $\Delta T \sim 20 - 30^\circ C$

- Another approach to calculate the dissipated power:

- $W = \dot{m}C_p\Delta T$
- $\dot{m} = \rho \frac{dV}{dt}$ is the mass flow rate water
- $C_p = 4,18kJ /kg/K$ is the specific heat of water

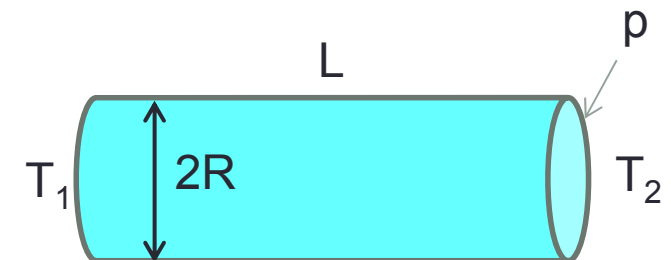

Copper Coil Interlocks

- Interlocks are there to check the good cooling of the coil
 - Water flow threshold (on the low pressure side)
 - Thermoswitch 60-70°C set in serial
- The power supply is stopped in case of a lack of cooling

Example of Waterflow switch

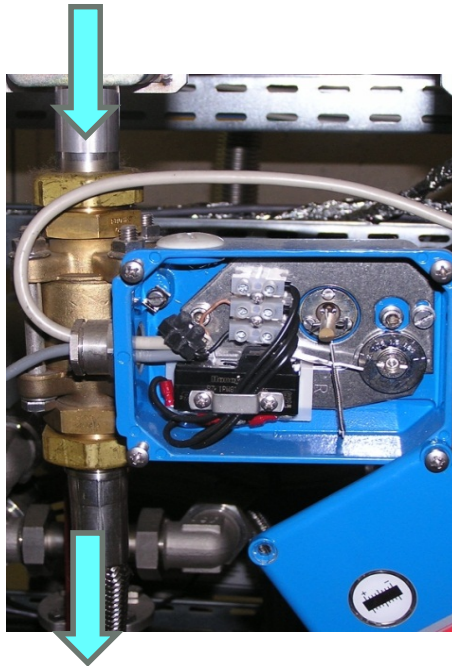

Thermoswitch



Combining coils and ferromagnetic materials

- The high magnetization saturation $M \sim 2.15$ T of low carbon Iron Alloy is very useful to design relatively high magnetic fields structure using room temperature magnets
 - Dipole, quadrupoles, ECR Ion sources...

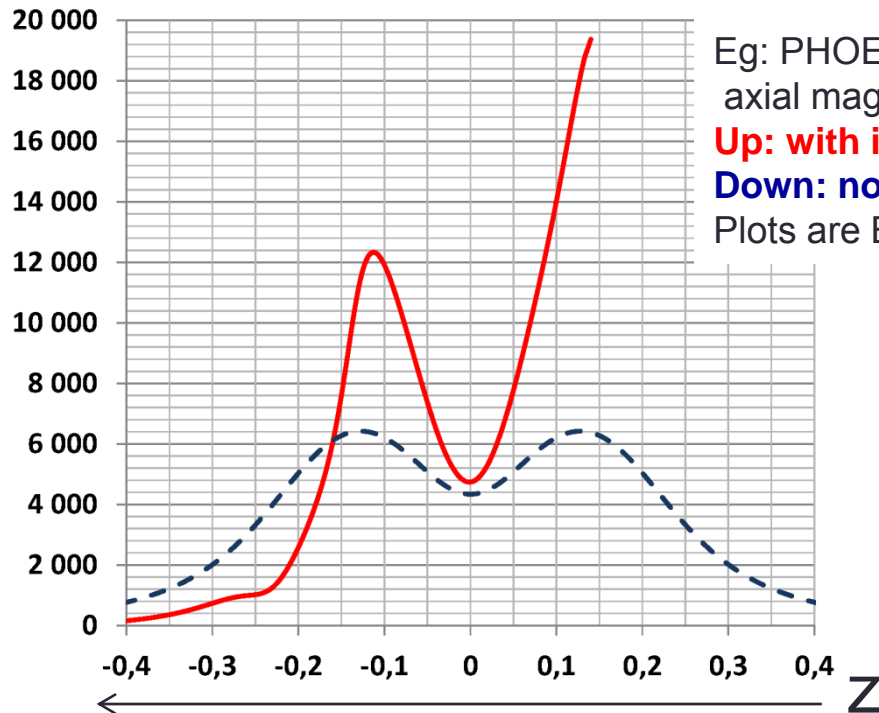

Eg: PHOENIX V2 ion source axial magnetic structure
Up: with iron
Down: no iron
 Plots are $B_z(z)$ on axis (Gauss)

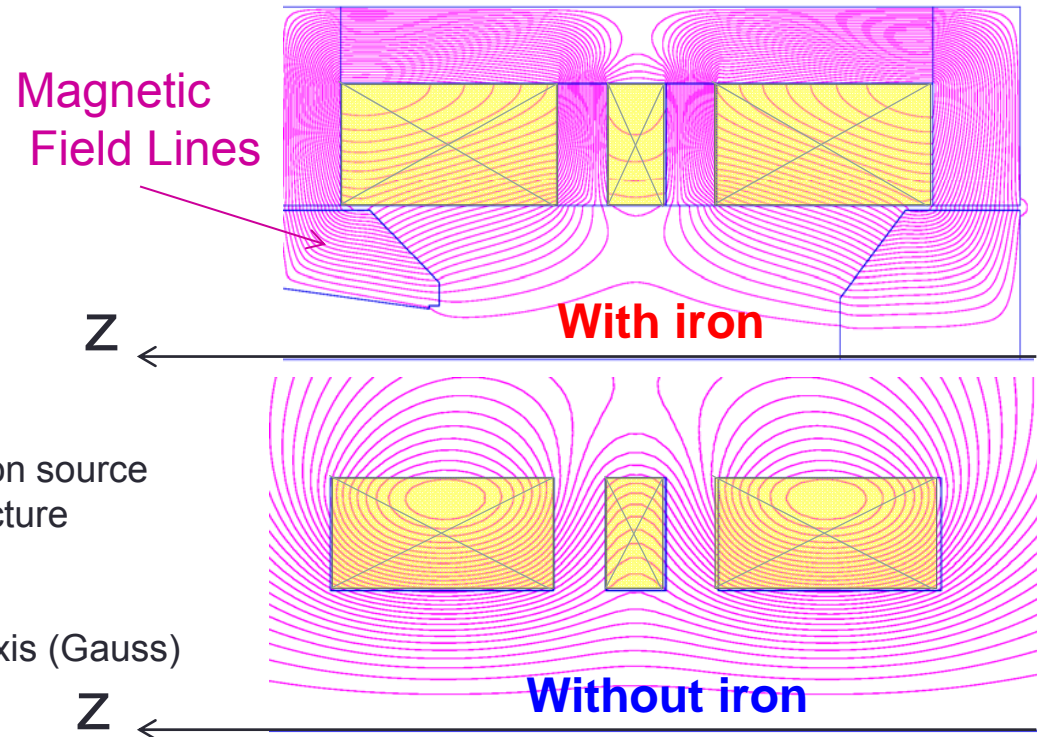

- The magnetic flux generated by the coils is totally canalized by a well optimized soft iron geometry to reach higher magnetic field intensity
 - Magnet Designers are surfing on $div(\vec{B}) = 0$

High magnetic Field Copper Coil

- The Bitter Coil technology
 - Thin (punched) Cu discs are stacked one on each other, separated by an electrical insulator
 - The stack is mechanically clamped to allow a good electrical contact between Cu discs and magnetic force containment
 - The water cooling is done axially through holes performed in the discs
 - Heat exchange through forced convection is highly optimized ($h > 10000-30000$)
 - $J \sim 100-300 \text{ A/mm}^2$
 - $B \sim 20-35 \text{ Tesla!}$
 - $P \sim 5-20 \text{ MW!}$
 - $Q \sim 100-400 \text{ l/s!}$
 - Works better at high field (risk of loosy contact between discs for low J => destructive arc)

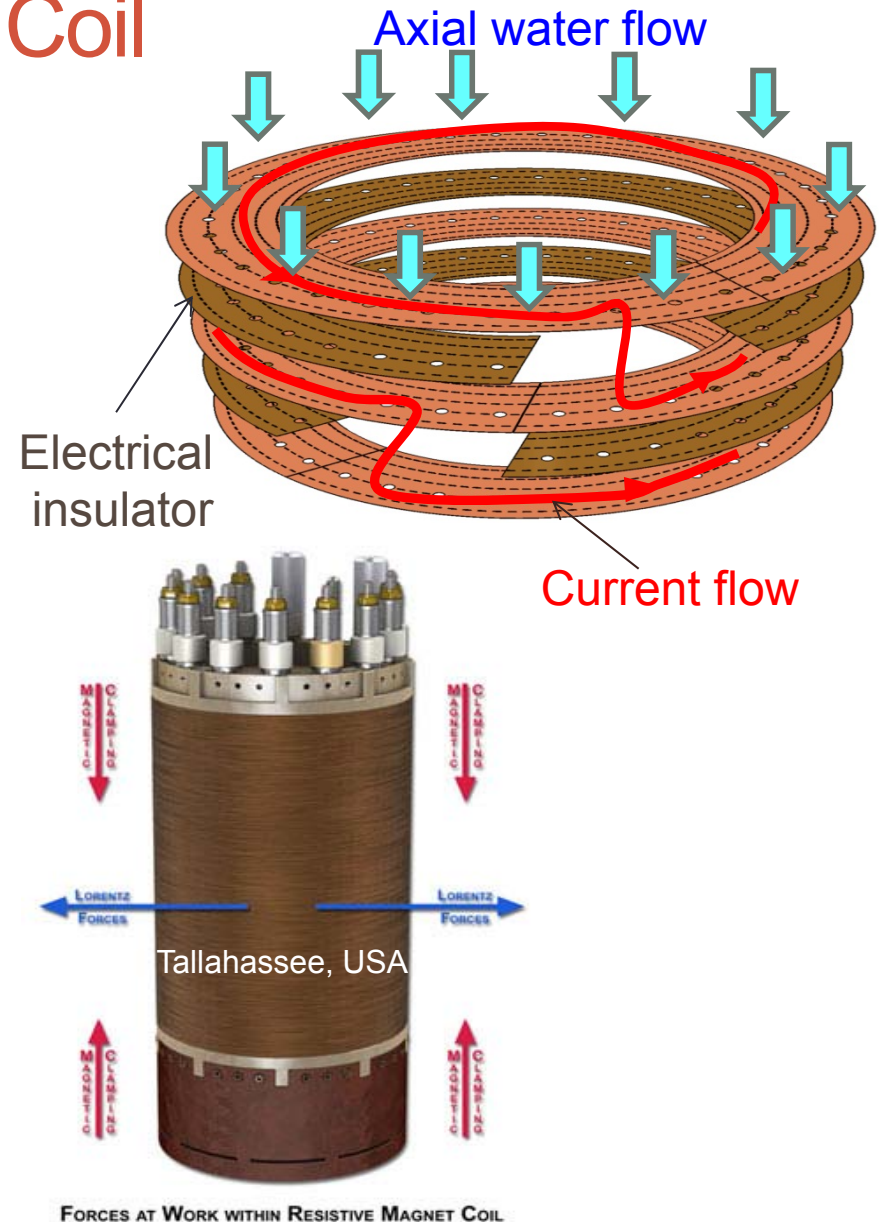

High magnetic Field Copper Coil

- The PolyHelix Technique

- The coil is directly produced in a raw Cu cylinder (electro-discharge machining)
- The coil is radially cooled
- The current density can be continuously changed
- The continuous change of the helix pitch allows a local adaptation of the current density and enables to tune the magnetic field profile finely
- The small gaps are spaced with kapton insulators
- $J \sim 100\text{-}300 \text{ A/mm}^2$
- $B \sim 20\text{-}35 \text{ Tesla!}$
- $P \sim 5\text{-}20 \text{ MW!}$
- $Q \sim 100\text{-}400 \text{ l/s!}$

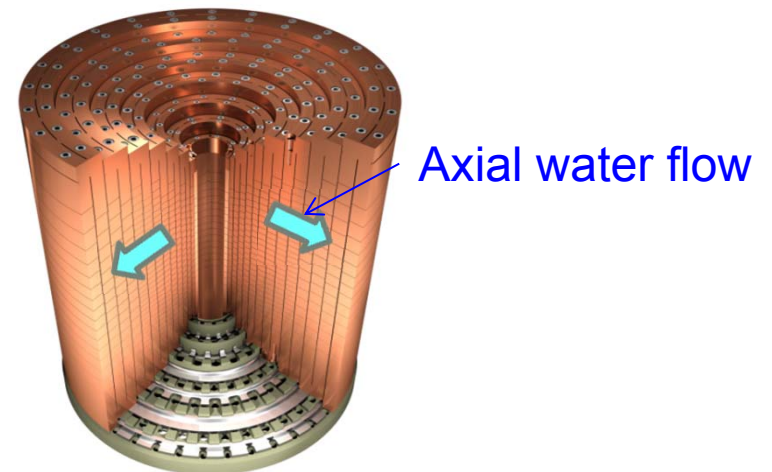
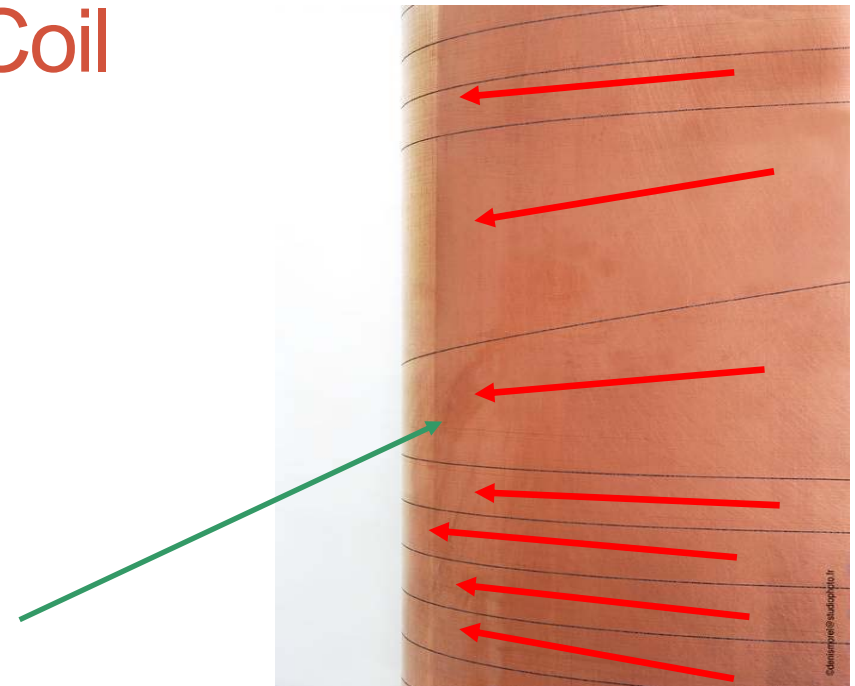

Grenoble, France



High magnetic Field Coil environnement

- Schematic of a DC High Field Facility (Nijmegen, Tallahassee, Grenoble, Tsukuba...)

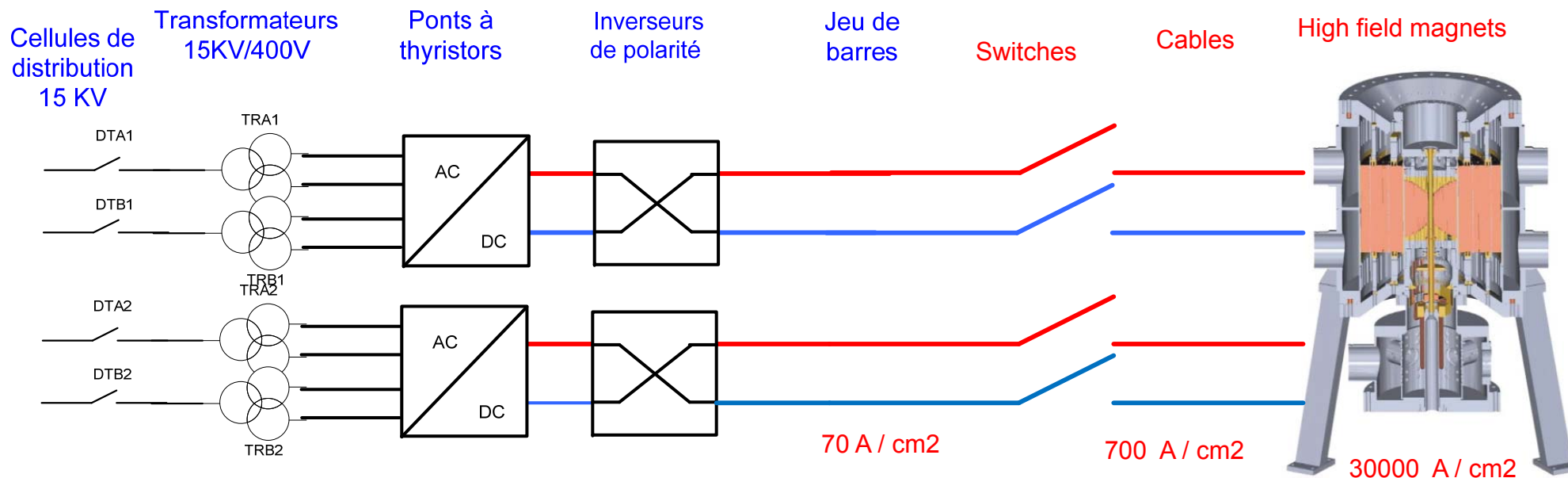

$I = 16000 \text{ A (20 ppm)}$
 $U = 400 \text{ V}$

Aluminum bars to bring the current

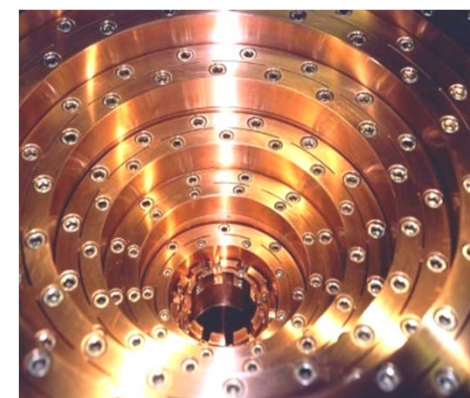

Superconductivity

- Superconductivity (SC) is a state of matter characterized by two specific properties:
 - **A zero electrical DC resistance:** the current flows without any Joule effect loss, so with a zero voltage drop => electrical power saving
 - **The Meissner effect:** When the material makes the transition between normal to SC state, it expells out all its magnetic field lines
 - Large currents are flowing on the surface of the SC that exactly compensate the externally applied magnetic field to reach $B=0$ inside
 - The penetration depth of currents inside the SC is $\lambda \sim 100$ nm! (λ =London penetration depth)

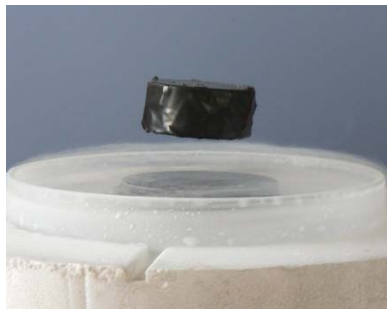

Spontaneous levitation of a SC above a magnet, Induced by the surface currents Generated by the Meissner effect
(Source: wikipedia)

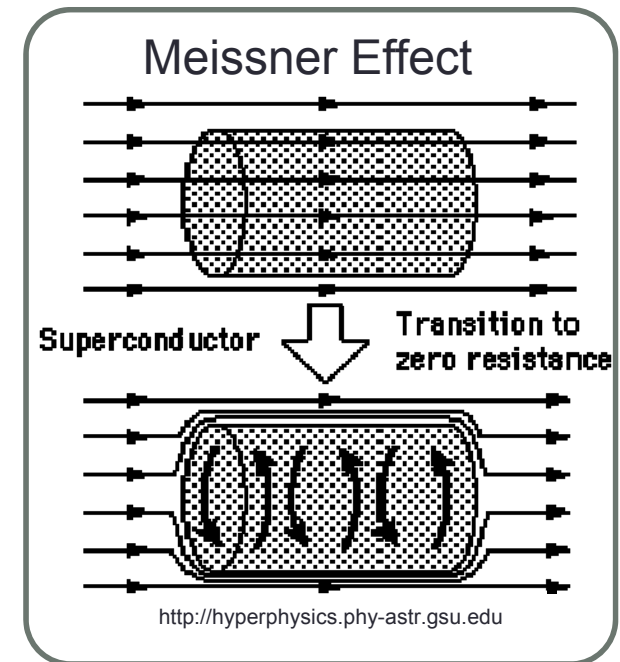
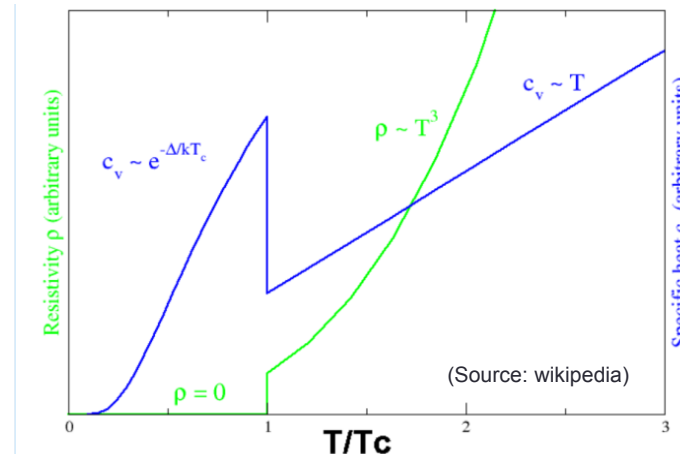

Condition to keep Superconductivity State

- Threshold temperature T_c :
 - $T < T_c(J, H)$
 - $T \sim 4-20$ K
- Threshold Magnetic Field H_c :
 - $H < H_c(T, J)$
 - $H \sim 2-12$ T
- Limited Current density J_c :
 - $J < J_c(H, T)$
 - $J \sim 0.1-10$ kA/mm²
- SC transition = 2D surface in (T, B, J) space

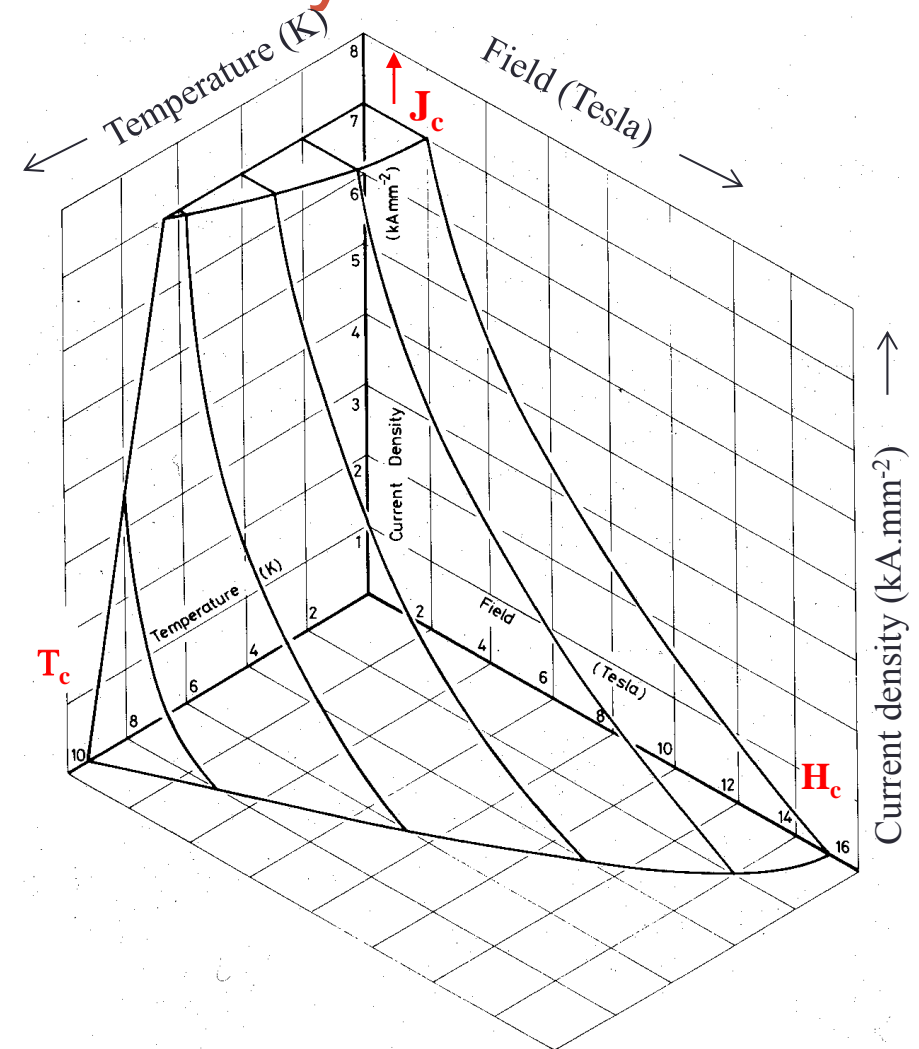

Source: M. Wilson, JUAS 2006

Type I & II Superconductors

• Type I: Low Temperature SC (LTS)

- NbTi, Nb₃Sn...

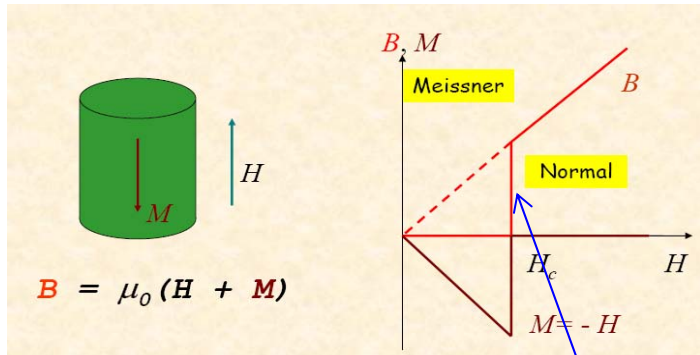

- one critical T_c
- one critical H_c

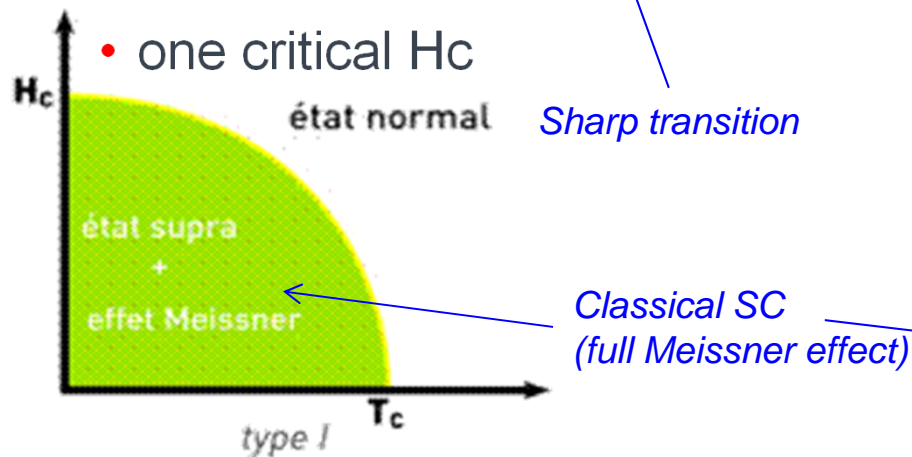

• Type II: High(er) Temperature SC (HTS)

- YBCO, Bi-2223, MgB₂...

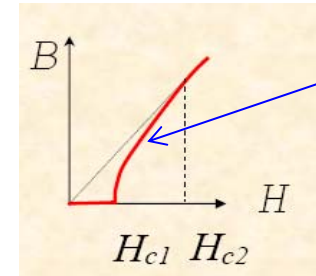

- H < H_{c1} classical Meissner effect
- H_{c1} < H < H_{c2} some magnetic vertexes penetrates the HTS

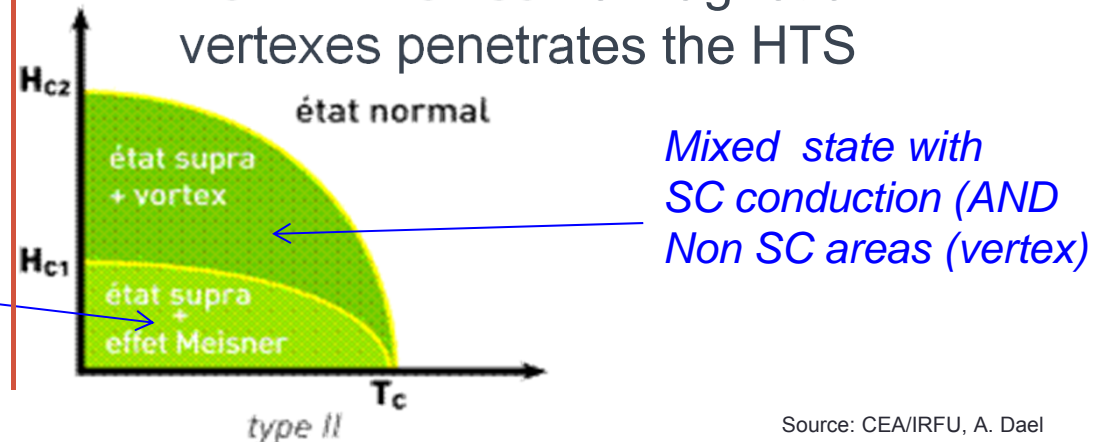

Source: CEA/IRFU, A. Dael

SC wires

- Strand Wire
 - Usually combined with Cu
 - Cu is a good conductor and reduces heat when NbTi is not in SC state
- Cable
 - A set of strands to produce high current cables
 - e.g. LHC cable

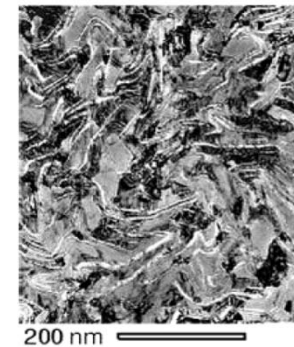
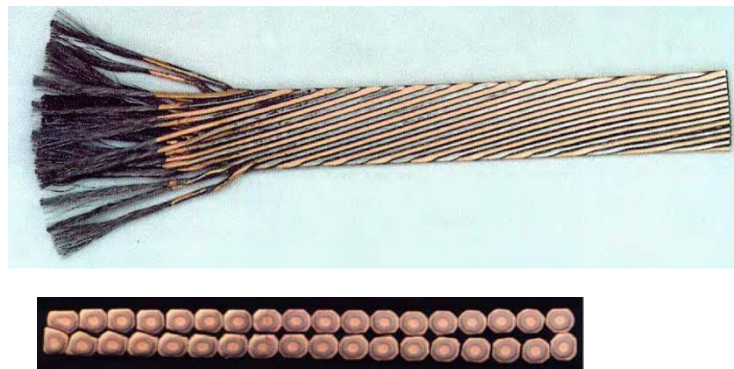

200 nm

Rutherford cable

6 μm

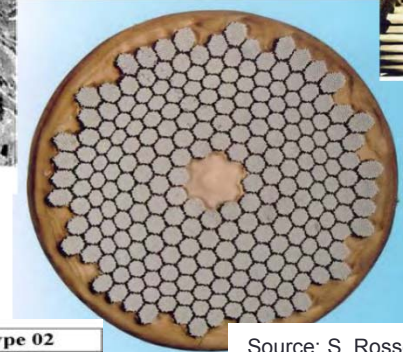
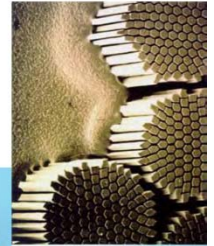

1 mm

LHC SC cable

STRAND	Type 01	Type 02
Diameter (mm)	1.065	0.825
Cu/NbTi ratio	1.6-1.7 ± 0.03	1.9-2.0 ± 0.03
Filament diameter (μm)	7	6
Number of filaments	8800	6425
J _c (A/mm ²) @1.9 K	1530 @ 10 T	2100 @ 7 T
μ ₀ M (mT) @1.9 K, 0.5 T	30 ±4.5	23 ±4.5
CABLE	Type 01	Type 02
Number of strands	28	36
Width (mm)	15.1	15.1
Mid-thickness (mm)	1.900 ±0.006	1.480 ±0.006
Keystone angle (degrees)	1.25 ±0.05	0.90 ±0.05
Cable I _c (A) @ 1.9 K	13750 @ 10T	12960 @ 7T
Interstrand resistance (μΩ)	10-50	20-80

Source: S. Rossenckuck, JUAS

Conductor for NMR magnet

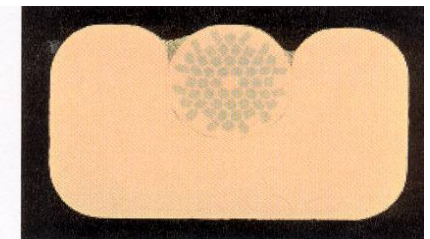
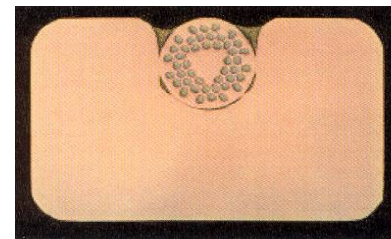

Wire in Channel

a x b = 1.10 x 1.70 mm² : 2.15 x 4.25 mm², Cu : NbTi ratio 10 to 20

Source: A. Dael, IRFU

Challenges to design a SC coil

- Electromagnetic Design
 - Design the appropriate magnetic field with an appropriate current density
- Mechanical engineering
 - compute magnetic forces, design a technique to clamp the coil efficiently at low temperature
- Material Science, superconductivity
 - Use a SC cable in an appropriate way
- Cryogenic and vacuum engineering
 - Design the cryogenic system to ensure an appropriate temperature and cooling working point, able to resist to ANY accidental problem
- Electronic engineering
 - Design the room and low temperature instrumentation part
 - Build up a quench protection system (see next slides) to damp the huge stored energy

Critical Lines at 4.2 K

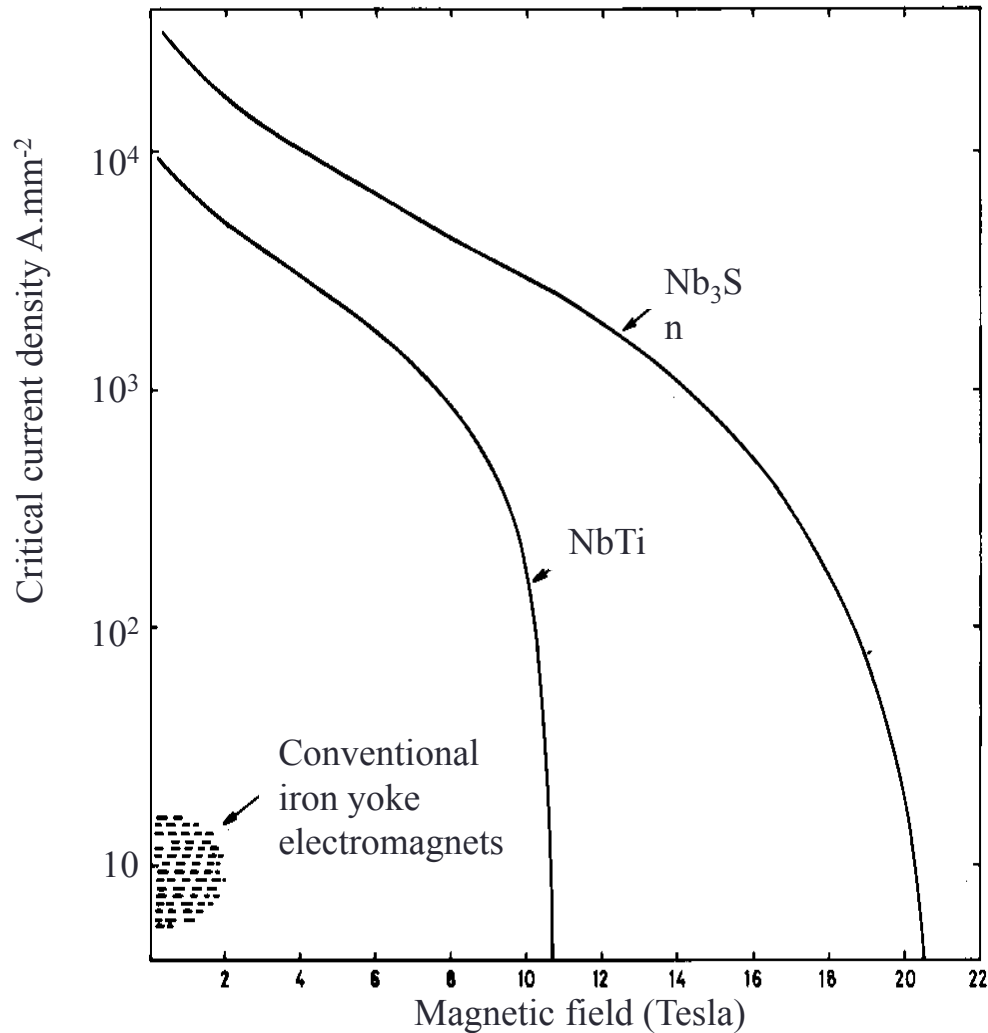

- because magnets usually work in boiling liquid helium, the critical surface is often represented by a curve of current versus field at 4.2K
- niobium tin Nb₃Sn has a much higher performance in terms of critical current field and temperature than NbTi
- but it is brittle intermetallic compound with poor mechanical properties
- note that both the field and current density of both superconductors are way above the capability of conventional electromagnets

M. Wilson Lecture – JUAS 2006

SC cable Quench

- A quench is the name for a local transition of a cable from SC to normal conducting state
 - Once the quench occurred, the cable becomes locally resistive: the heat generated may possibly enlarge the non SC area and the quench may propagate and increase dramatically the cable temperature because of Joule Heating
 - RISK OF CABLE DESTRUCTION
 - The Magnet should be designed to resist to a quench
 - Once the quench has occurred, the magnetic energy stored is converted into heat. The coil temperature increases and one needs to wait for the cryostat cooling down to magnetize again the coil

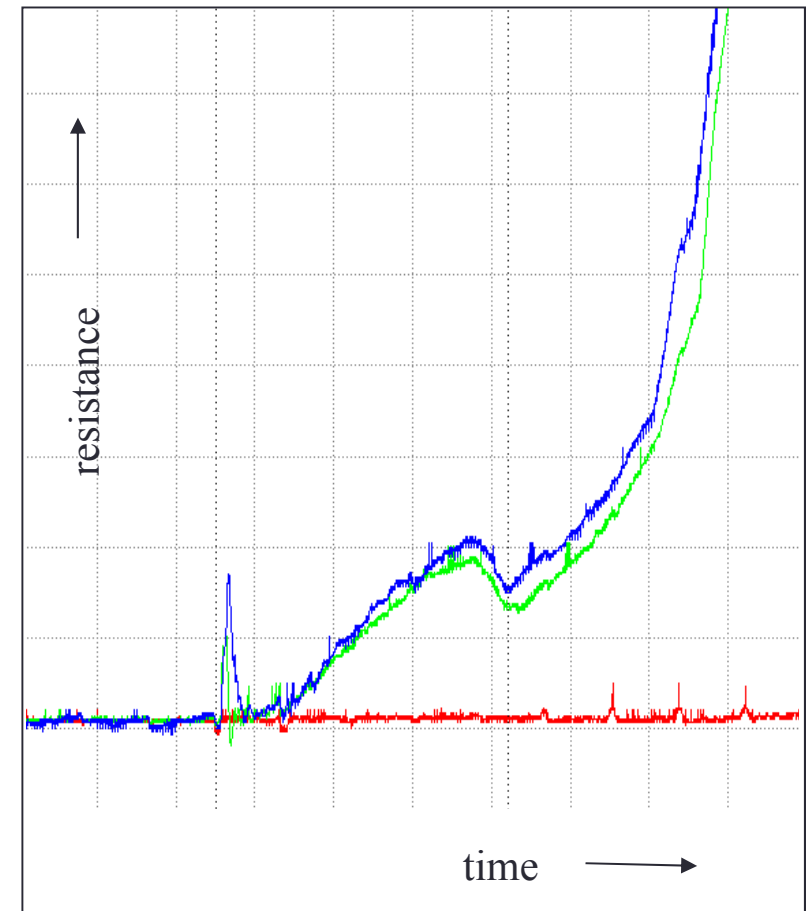

Quench initiation in LHC dipole

Source: M. Wilson Lecture – JUAS 2006

Causes of SC cable Quench

- Training quench
 - **A new coil does not reach directly reach its designed operation current, but undergoes several quenches before reaching it, at currents intensities lower than the expected SC cable properties**
 - The coils epoxy impregnation may crack a little when is it cooled down to low temperature, due to difference in mechanical contraction with the surrounding metal. At early magnetization cycles, micrometric imperfections in the epoxy impregnation of the coil may locally uncomensate the local force acting on the wire $F \sim J \cdot B \cdot R$. The local crack of epoxy dissipates a local energy that heats the wire which switches to normal conducting state.
 - A micrometric move of the conductor may also generate a quench.
 - Usually, after several training quenches, the coil reaches its nominal value.
 - Sometimes, it doesn't... This is very bad: The coil is good for garbage!
 - **$H > H_c$ or $J > J_c$ or $T > T_c$**
 - if the SC cable sees locally a thermodynamic/electromagnetic condition that overtakes its capability, it quenches. It is always the direct, or indirect cause of the quench



Source: M. Wilson Lecture – JUAS 2006

Coil Load Line – Safety margin

- Magnets are usually designed to work with a current density at 50-80% of the SC limit

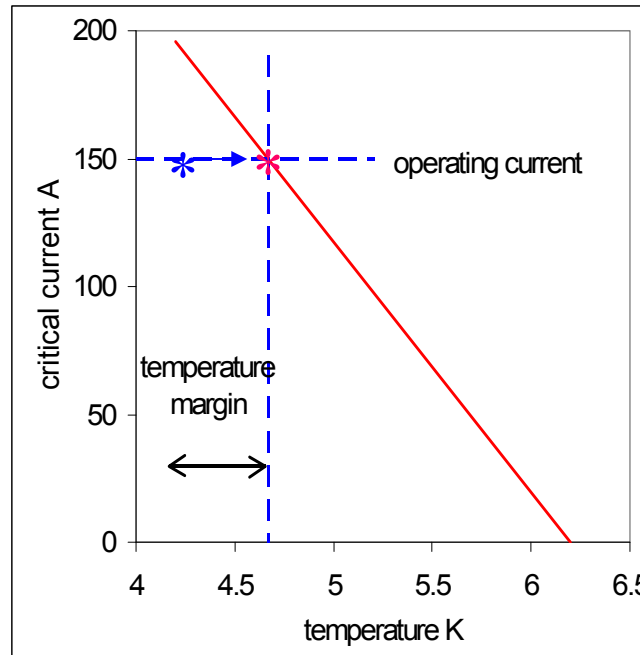
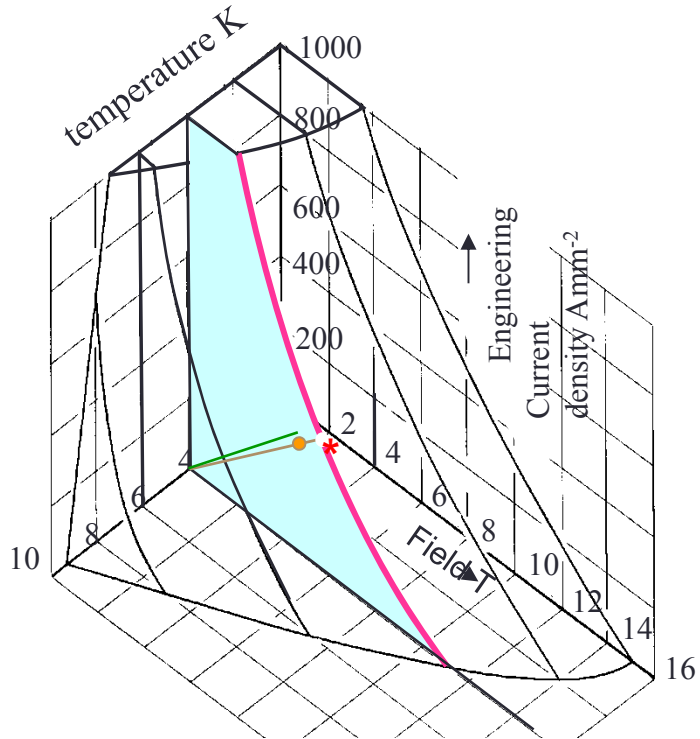

M. Wilson Lecture – JUAS 2006

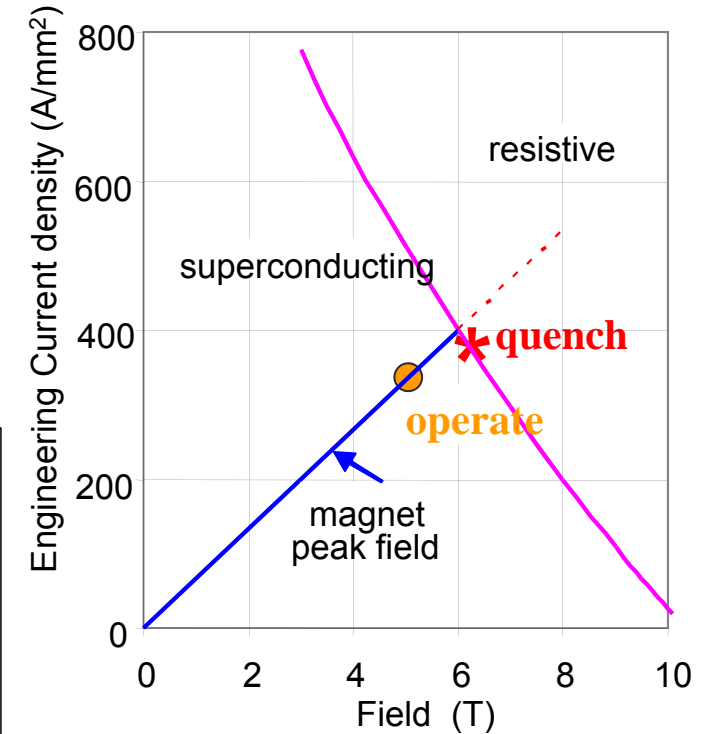

- As a consequence, this gives a temperature margin that reduces risk of quenching

Heat generated by a quench – Cu stabilization

- At low temperature ($T \sim T_c$)
 - $\rho_{Cu} \ll \rho_{NbTi}$
 - $\lambda_{Cu} \gg \lambda_{NbTi}$
- If a quench occurs in NbTi, the current will flow in Cu ($\rho_{Cu} \ll \rho_{NbTi}$), and the Joule heat will be much smaller
- The high Cu thermal conductivity will allow the local heat dissipation and the quench may not propagate

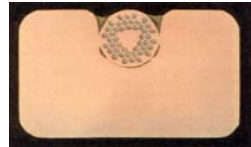

	Cu	NbTi
Electrical Resistivity ρ ($\Omega \cdot m$)	3×10^{-10}	7×10^{-7}
Thermal conductivity λ (W/mK/m ²)	350	0.1

Resistive coil (Cu)

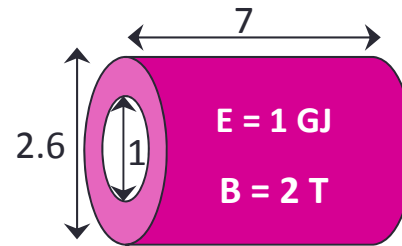

SC coil (no Cu)

Resistive part induced by quench

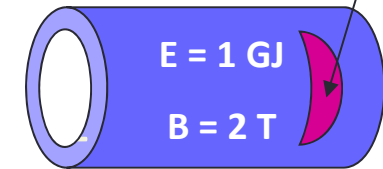

	Resistive Coil	SC Coil
Energy stored	1 GJ	1 GJ
J (A/mm ²)	2	$2 \times 10 \Rightarrow$ thickness/10
Total Volume (m ³)	32	1.9
Electromagnetic Energy \rightarrow Heat (J/m ³)	32×10^6	$V_{resistive} \sim V_{tot}/10$ $E/V_{res.} \sim 5 \times 10^9$
Final temperature Of resistive part	\Downarrow 65 K	\Downarrow 1400 K

Adapted from :A. Dael, IRFU, Journees accenerateur 2011

Basics of Quench detection / Protection System

- Quench protection with a dump resistor:

- The stored energy $E = \frac{1}{2}LI^2$ is dumped in an external resistance

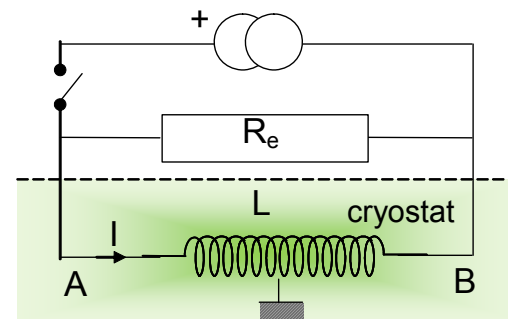

$$I = I_0 e^{-\frac{t}{\tau}}$$

$$\tau = \frac{L}{R_e}$$

- Quench detection:

- $V_{coil} = L \frac{dI}{dt} + rI$ ← Quench effect
- Wheatstone Bridge Circuit
 - No quench: bridge equilibrated: $V=0$
 - Quench: $V_{bridge} \sim rI \Rightarrow$ detection

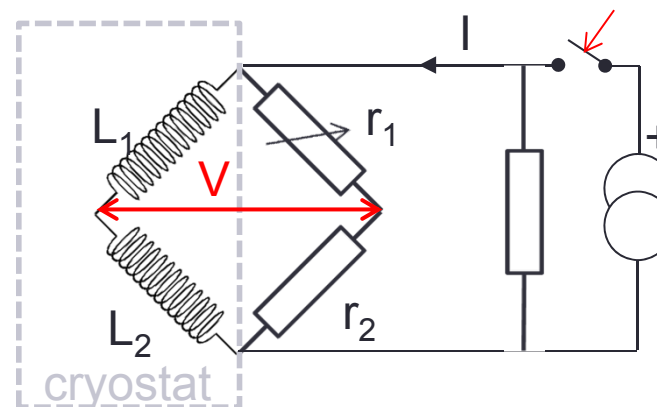

- Many other system exists

The World's Largest : CMS Superconducting Coil

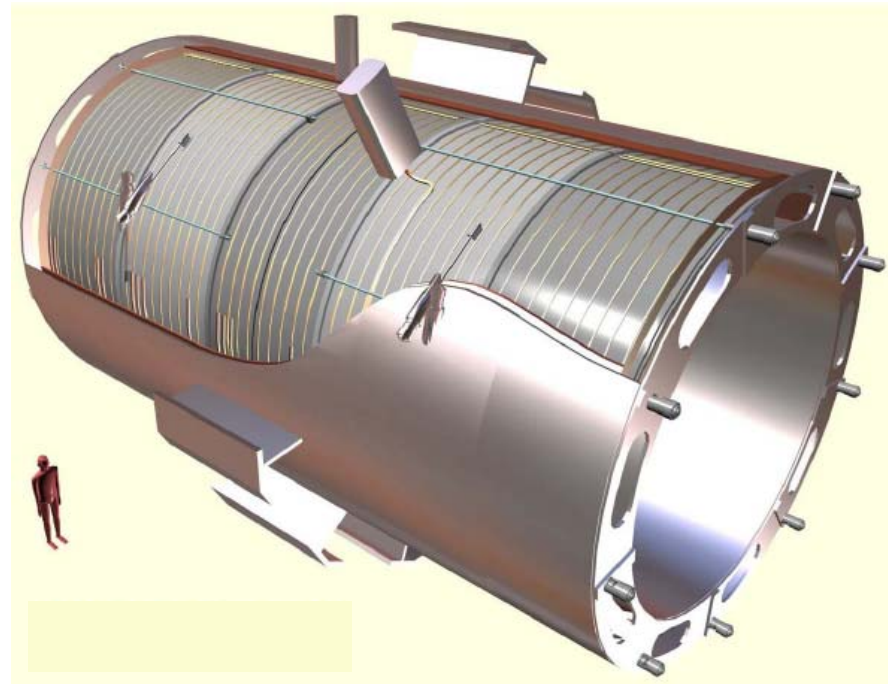

CMS solenoid

4T at 20,000A

6 m diameter 12.5m long

stored energy 27000MJ

Source: M. Wilson Lecture – JUAS 2006

Design of a simple HTC Coil (type II)

- Example of a 2.2 T HTC Coil (LPSC)
 - Bi-2223 tape
 - $J \sim 100 \text{ A/mm}^2$
 - $T \sim 15 \text{ K}$
 - Coil is under vacuum (no convection)
 - Cooling is done with a cryocooler cooling is transferred to coil through a Cu Braid
 - Superinsulation to reduce radiation heat
 - $I \sim 160 \text{ A}$, $L \sim 1 \text{ Henry}$, $B = 2.2 \text{ T}$ on axis

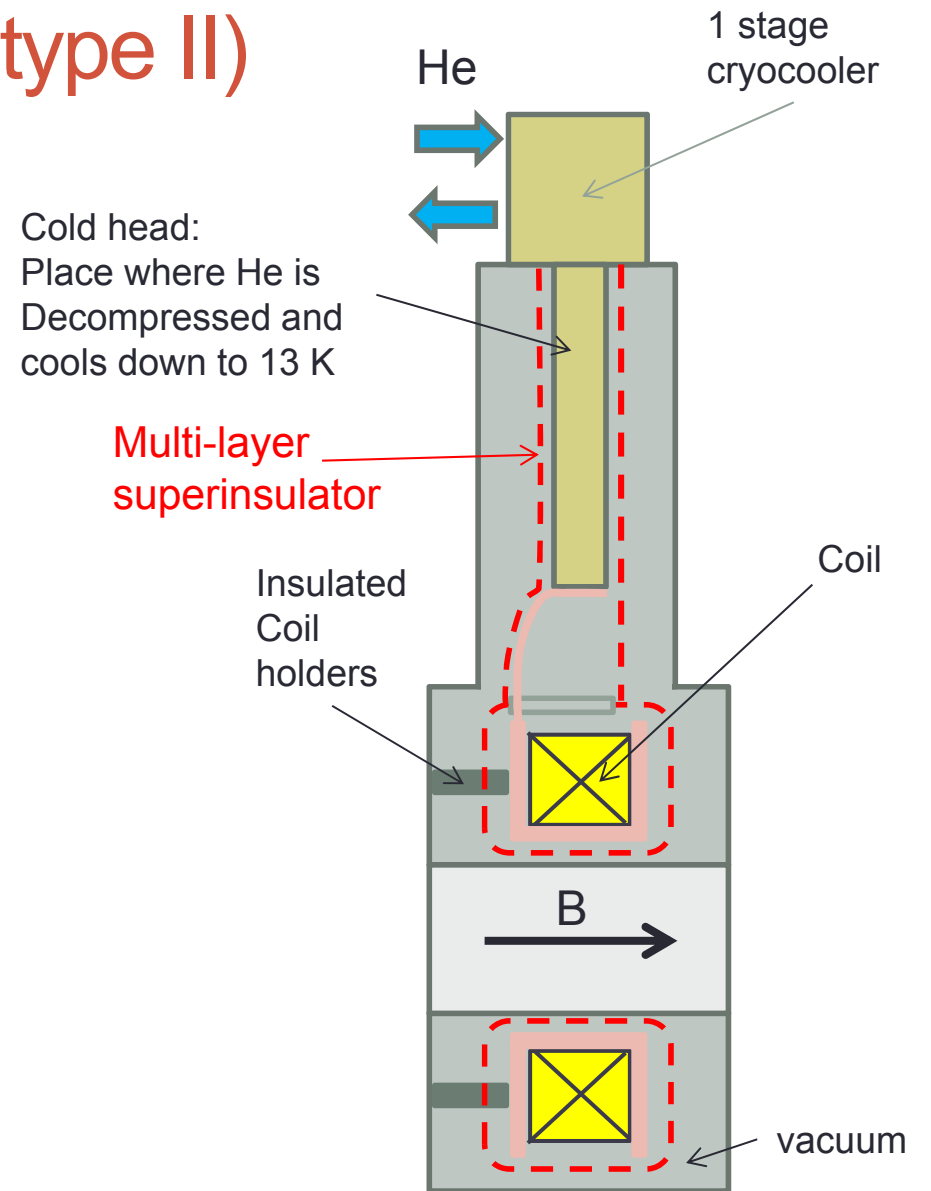
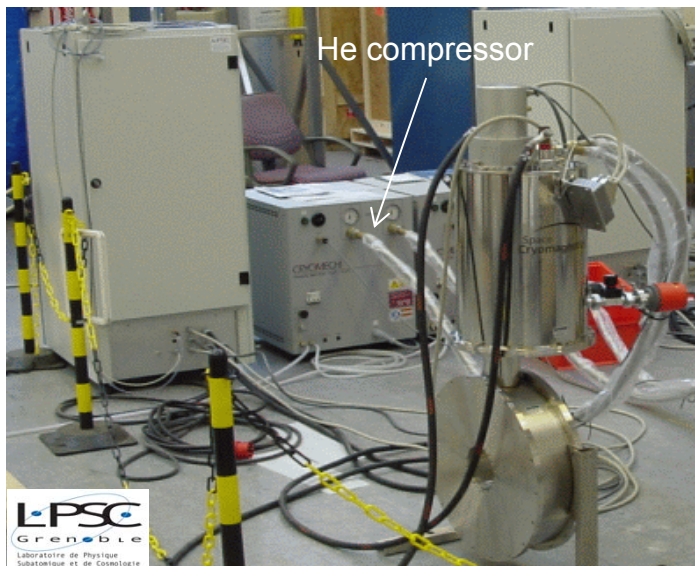

Liquid Helium Free HTC Coil at LPSC

Design of a sophisticated NbTi SC magnet cryostat

- VENUS ECR Ion Source Cryostat (LBNL)

- Axial Mirror 4-0.4-2.5 T
- Hexapole 2.2 T
- NbTi:Cu wire
- LHe bath
- 50 K shielding
- 2 stage cryocoolers

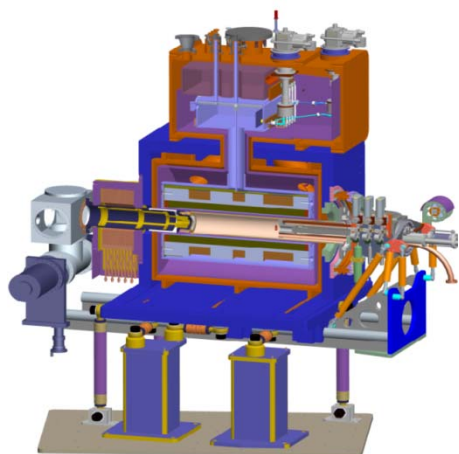
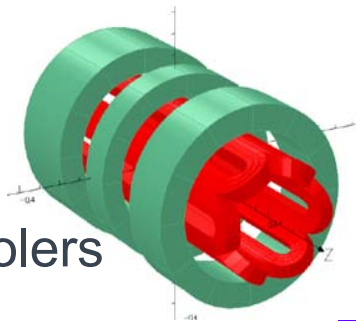

VACUUM VESSEL
275 K
50k Shield
4.2k liquid He vessel

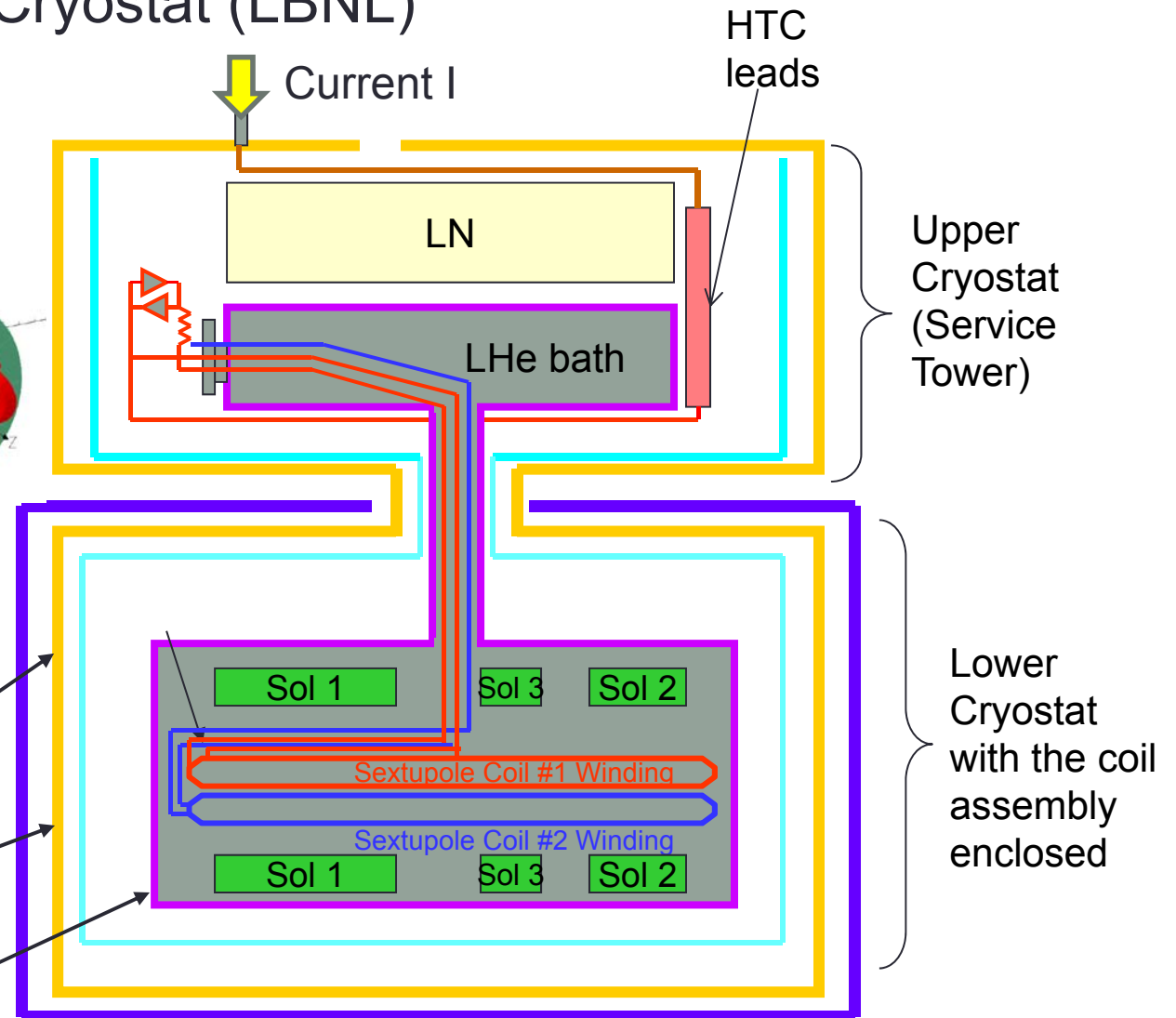

Techniques used to wind and clamp VENUS coils (LBNL)

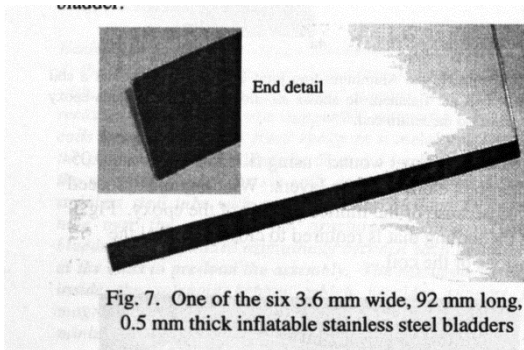

Bladders inserted here, then inflated

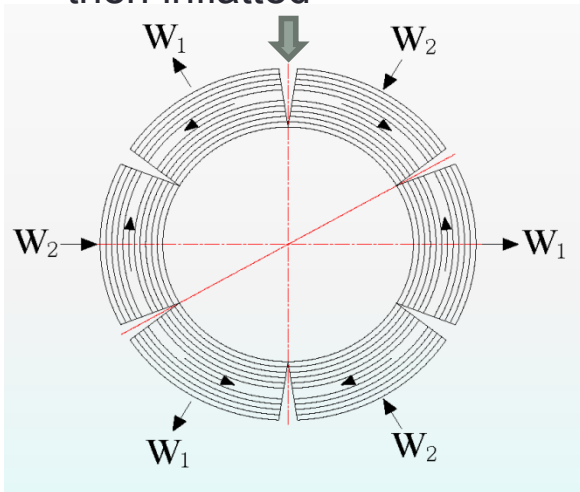

Once bladders inflated, coils are pre stressed

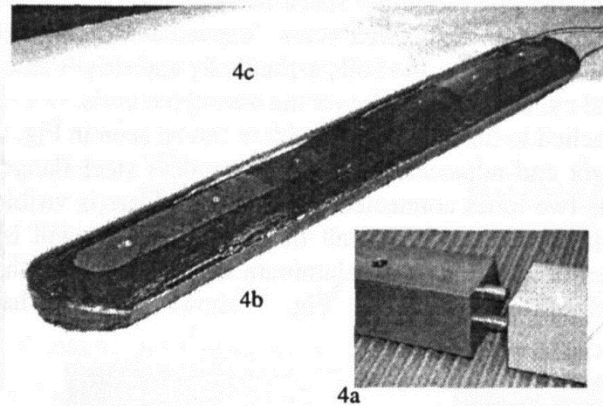

Hexapole Coil with central Iron yoke(magnetic boost) +Al part to adapt to magnet contraction @ 4K

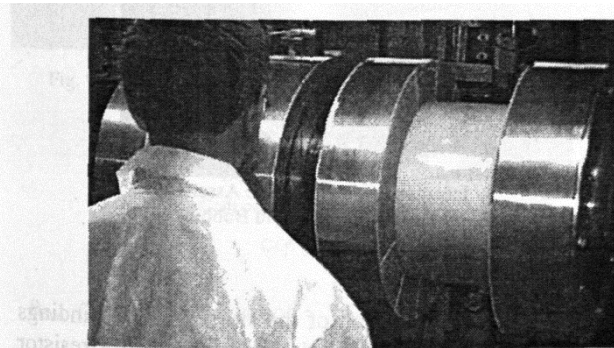

Fig. 3 Winding of the solenoid coils

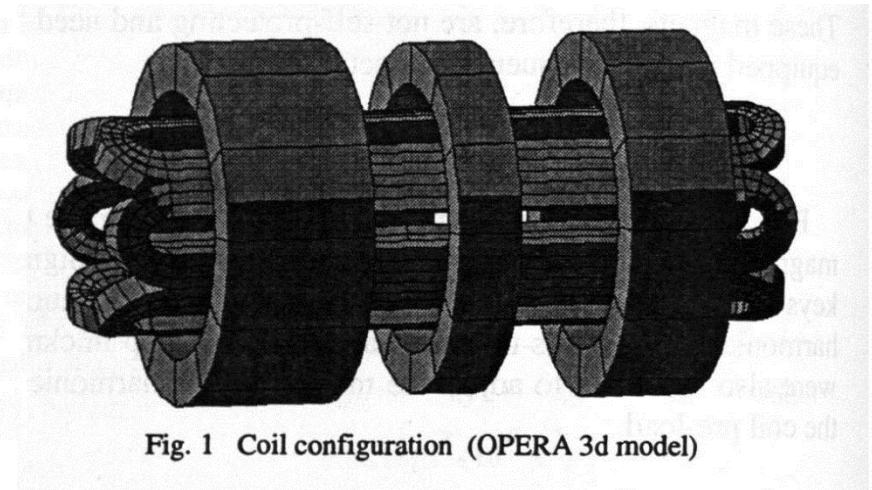

Fig. 1 Coil configuration (OPERA 3d model)

Source: IEEE Trans.Apl.Supercond.100,224(2000)

dimensions of the coil.

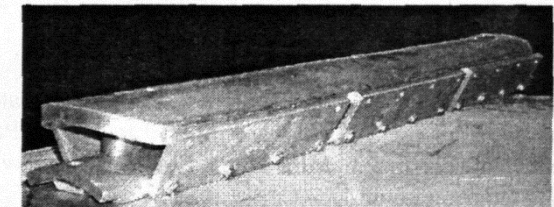

Fig.5 Sextupole Tooling

IV. ASSEMBLY OF THE SEXTUPOLE COILS

The six sextupole coils are placed around the 20 cm OD

Modern hexapole clamping (LBNL)

- Key insertion

Shell structure, bladders and keys to pre-stress the magnet structure
Advanced version of pre-stress first used successfully on VENUS

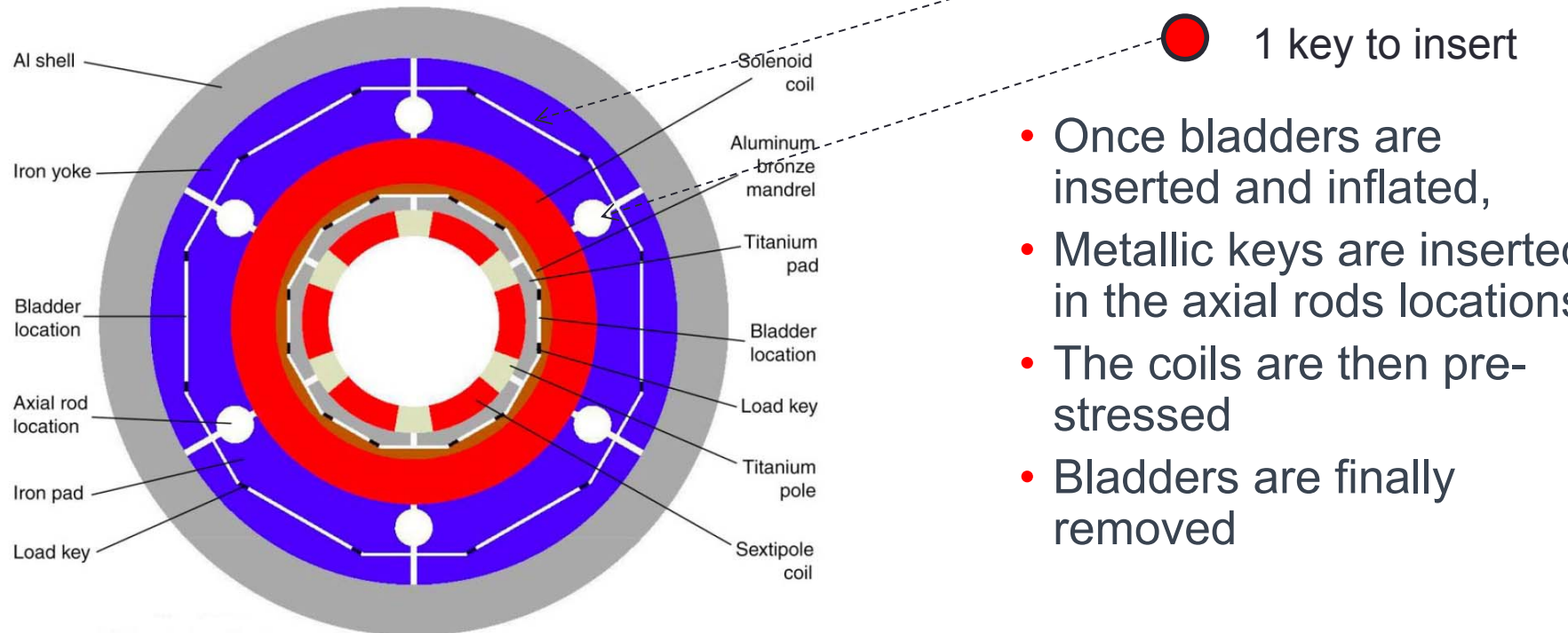

- Once bladders are inserted and inflated,
- Metallic keys are inserted in the axial rods locations
- The coils are then pre-stressed
- Bladders are finally removed



Source: ICIS 2011 9/16/11 C. Lyneis

Example of Stress on a modern SC coil

- 56 GHz ECRIS design study (7 T axial, 4 T radial field) LBNL

Source C.Lyneis, A. Hodginson, P. Ferracin, LBNL

coil stresses when the pre-load is sufficient to avoid coil-pole separation. In the "axial center" region (see Fig. 10, top), the coil reaches a pre-compressive stress of -84 MPa after interference key insertion.

Deformed shape of sextupole under combined e.m forces

(rigid support structure model)

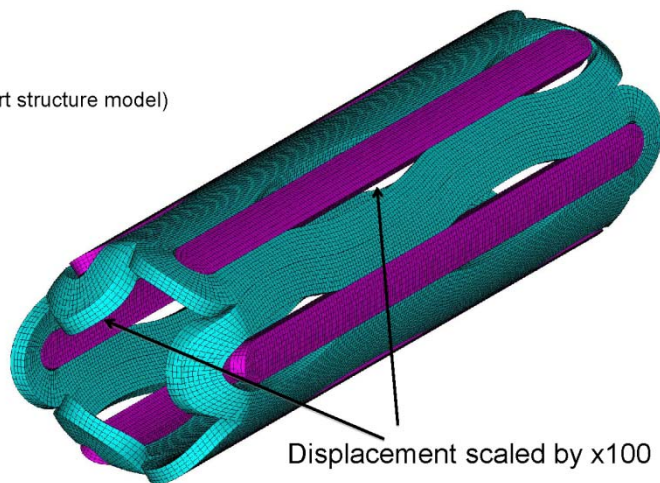

ICIS 2011 9/16/11 C. Lyneis

25

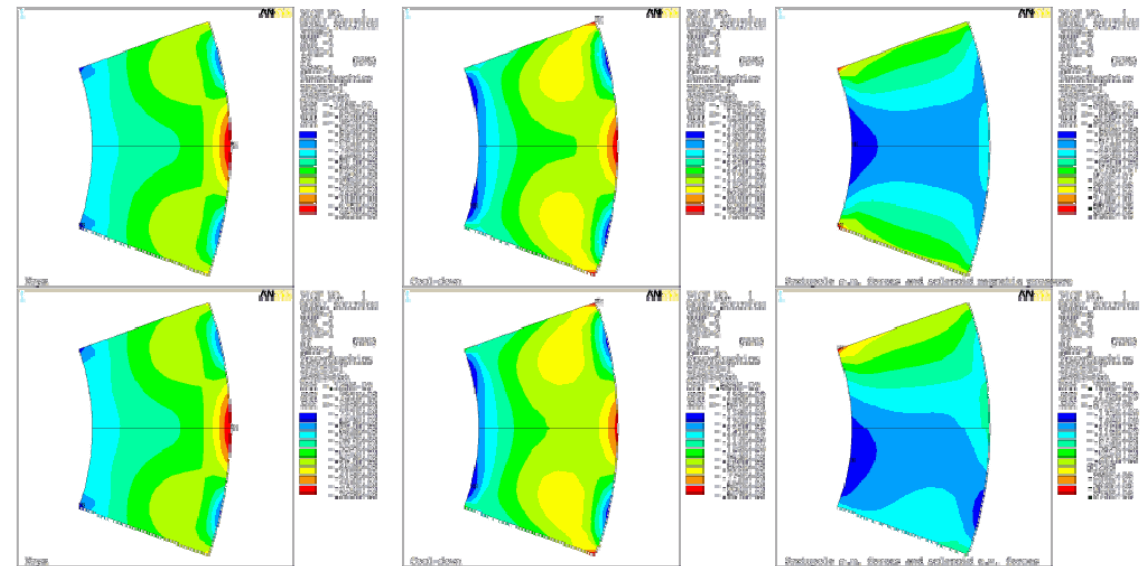
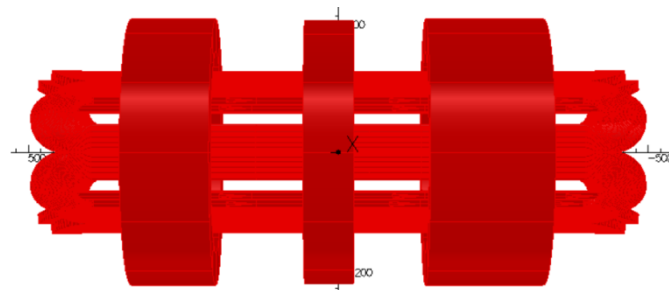

Fig. 10. Sextupole coil azimuthal stress (MPa) in the "axial center" (top) and "end region" (bottom).

axial coils generate extra forces on hexapolar coils



Hexapole Coils stress:
 -84 Mpa azimuthally
 ~135 Mpa axially