

Outcome of WebEx discussion with Tarkmet 2.9.2011

- **Pre-machining of accelerating structure (AS) discs** for Juha Väyrynen, North Karelia University of Applied Sciences (NKUAS).
- **Machining of parts for the PETS on-off system.**
- **Laser welding tests of vacuum manifolds for AS.**
Alternative to EBW.

PETS on-off system

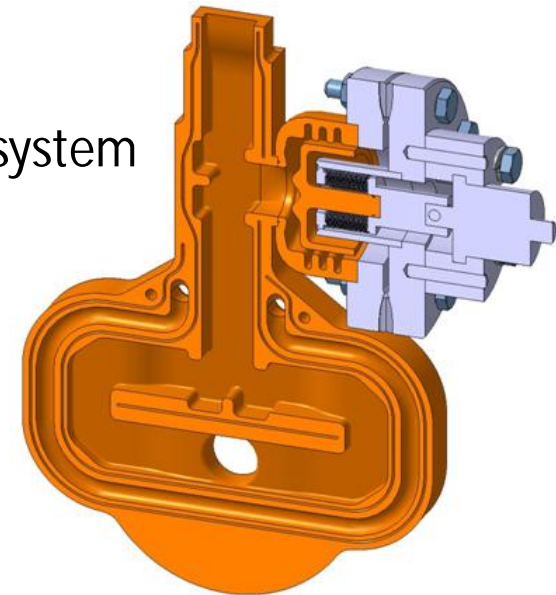

EBW welding of manifold covers and vacuum flanges

