

# Mid-circuit measurements in quantum simulations of lattice gauge theories: from the quantum Zeno effect to error correction

Matteo Wauters

CERN, 27<sup>th</sup> May 2025



Funded by  
the European Union

NeXST



UNIVERSITÀ  
DI TRENTO



Istituto Nazionale  
di Fisica Nucleare  
TIFPA  
Trento  
Institute for  
Fundamental  
Physics and  
Applications



Funded by the European Union. Views and opinions expressed are however those of the author(s) only and do not necessarily reflect those of the European Union or the European Commission. Neither the European Union nor the granting authority can be held responsible for them.

# Quantum simulations of lattice gauge theories

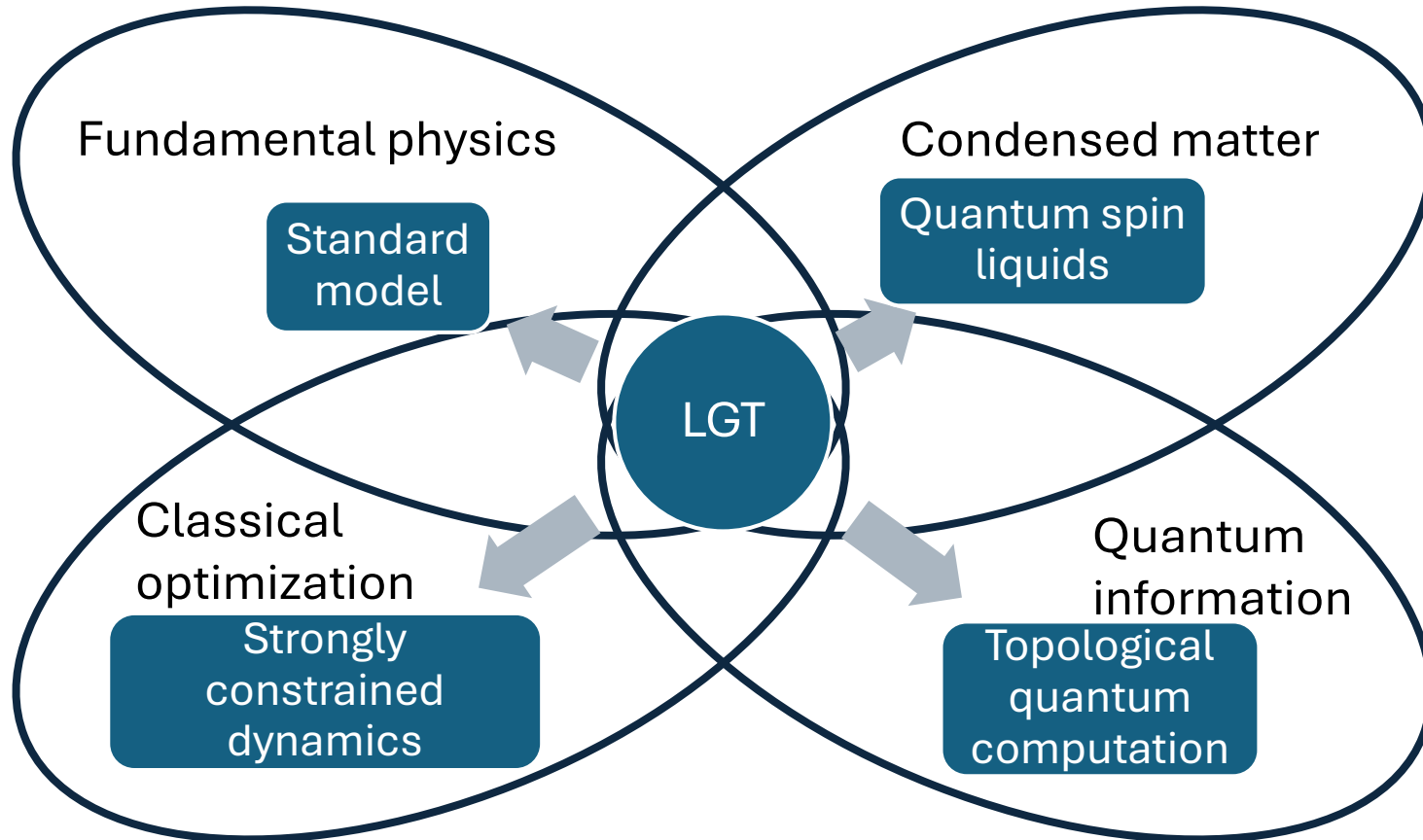

# Quantum simulations of lattice gauge theories

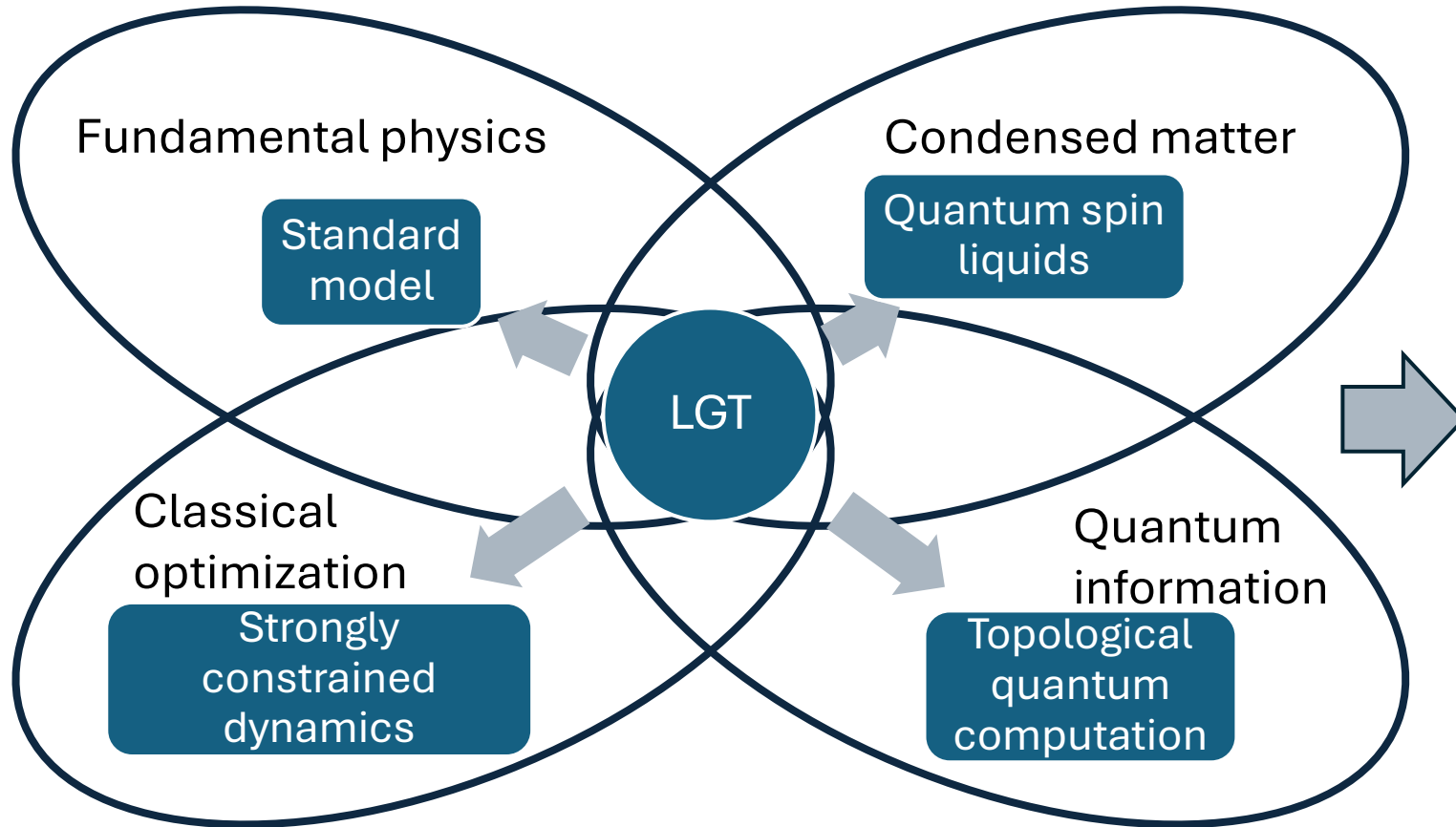

Quantum simulations of many-body physics

1. Go beyond classical methods
2. Hardware and software benchmark
3. Synthetic quantum systems

# Quantum simulations of **monitored** lattice gauge theories

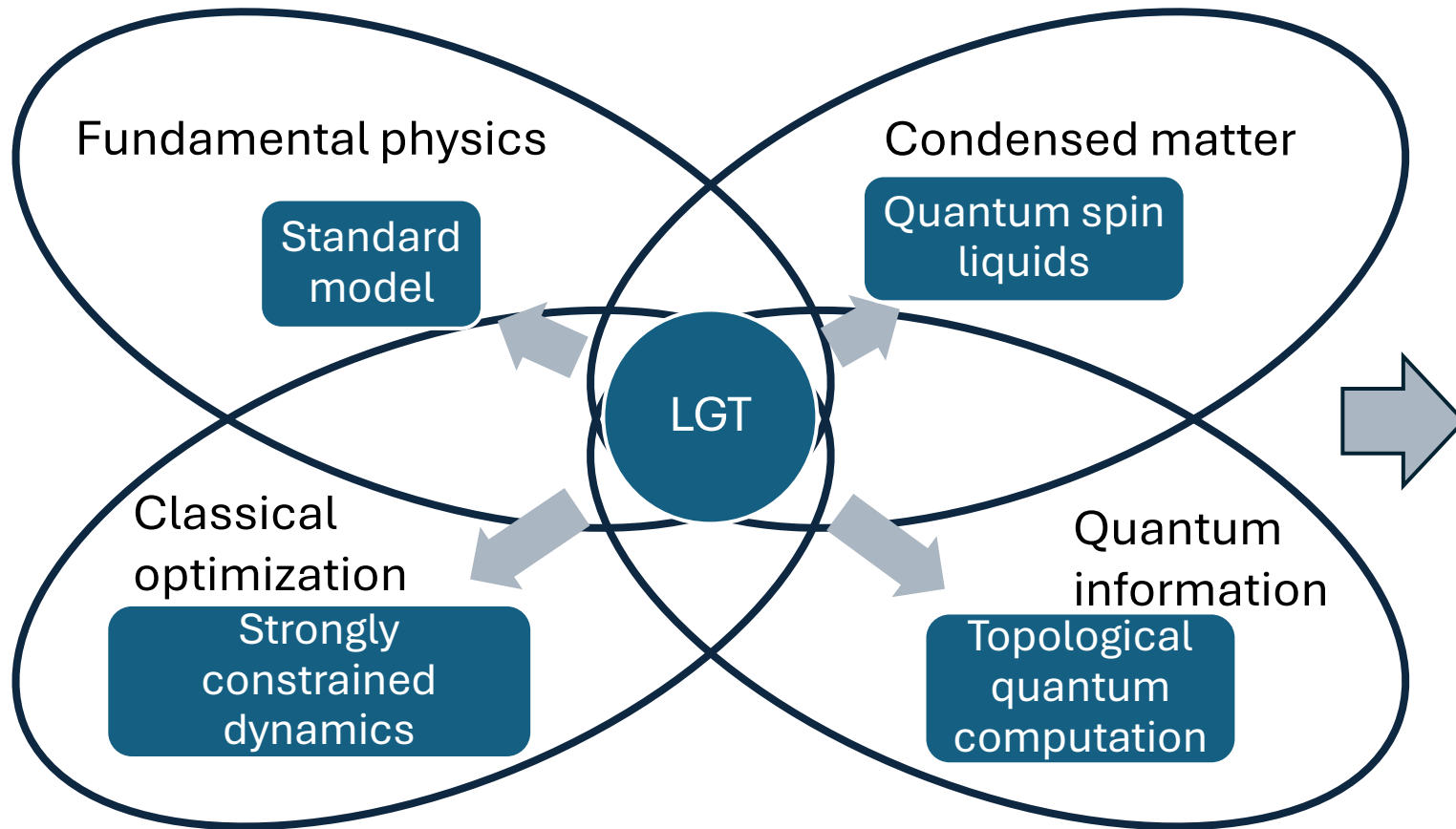

Quantum simulations of many-body physics

1. Go beyond classical methods
2. Hardware and software benchmark
3. Synthetic quantum systems



4. Interplay between simulation errors and measurements
5. Quantum error correction

# Quantum simulations of **monitored** lattice gauge theories

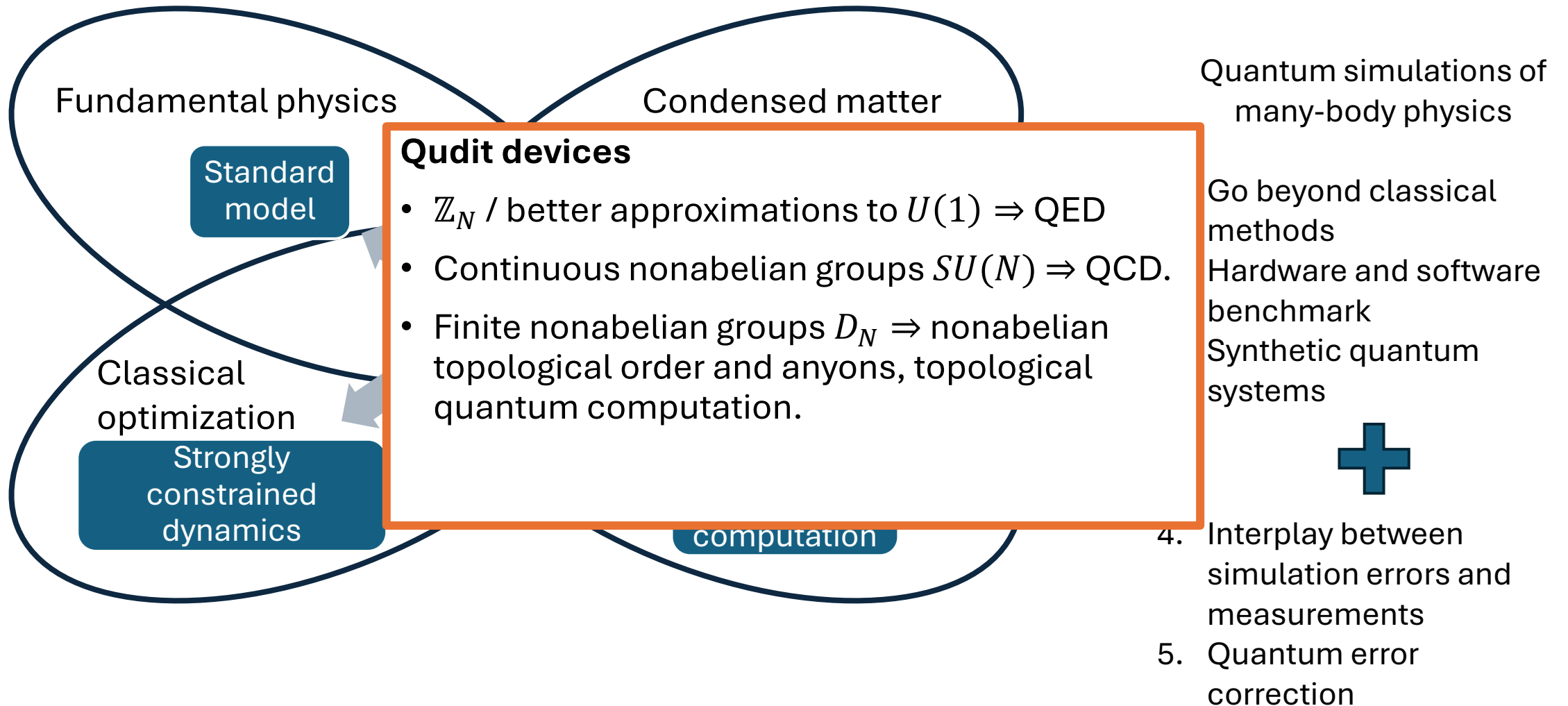

# Quantum simulations of lattice gauge theories

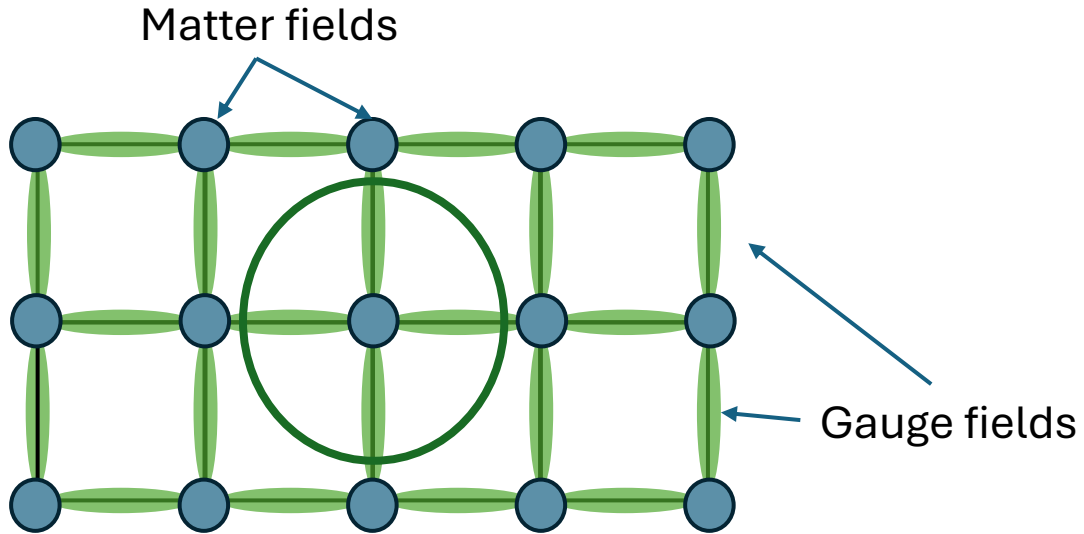

Local symmetry

$$U(1): \nabla \cdot \mathbf{E} = -\rho$$

$$\text{Lattice} \Rightarrow \sum_k (E_{\mathbf{r}+\mathbf{e}_k} - E_{\mathbf{r}-\mathbf{e}_k}) + \psi_{\mathbf{r}}^\dagger \psi_{\mathbf{r}} = 0$$

Gauge group  $G$

$$\Theta_{\mathbf{r}}(g) H \Theta_{\mathbf{r}}^\dagger(g) = H \quad \forall \mathbf{r} \in \mathbb{Z}^d, \forall g \in G$$

**Extensive number of symmetries**

# Quantum simulations of lattice gauge theories

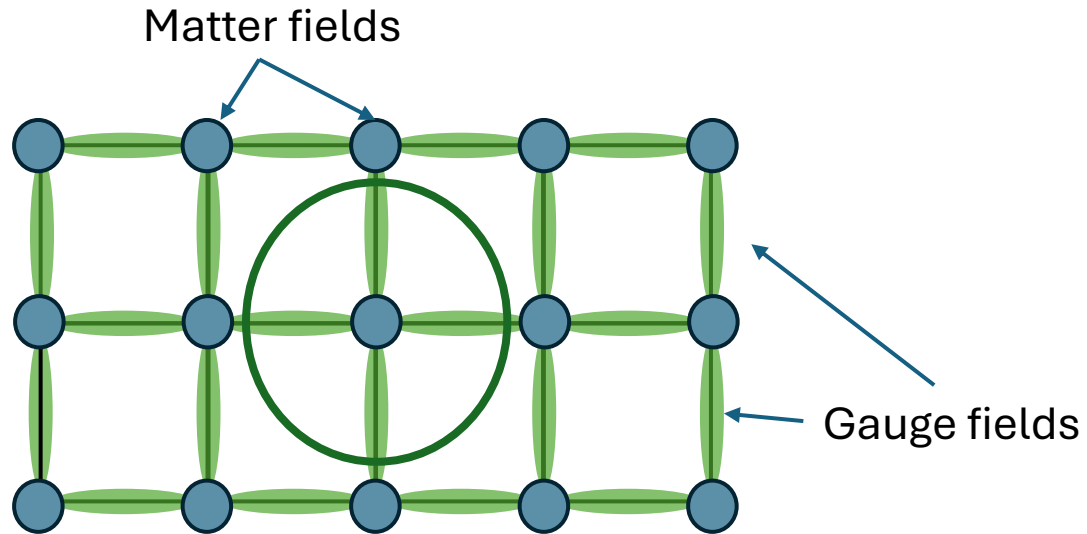

## Local symmetries to restrict to physical states?

Do: smaller Hilbert space, possibly nonlocal Hamiltonian, multi-body interactions

Don't: larger Hilbert space, local Hamiltonian, gauge symmetry breaking

### Local symmetry

$$U(1): \nabla \cdot \mathbf{E} = -\rho$$

$$\text{Lattice} \Rightarrow \sum_k (E_{\mathbf{r}+\mathbf{e}_k} - E_{\mathbf{r}-\mathbf{e}_k}) + \psi_{\mathbf{r}}^\dagger \psi_{\mathbf{r}} = 0$$

### Gauge group $G$

$$\Theta_{\mathbf{r}}(g) H \Theta_{\mathbf{r}}^\dagger(g) = H \quad \forall \mathbf{r} \in \mathbb{Z}^d, \forall g \in G$$

**Extensive number of symmetries**

# Quantum simulations of lattice gauge theories

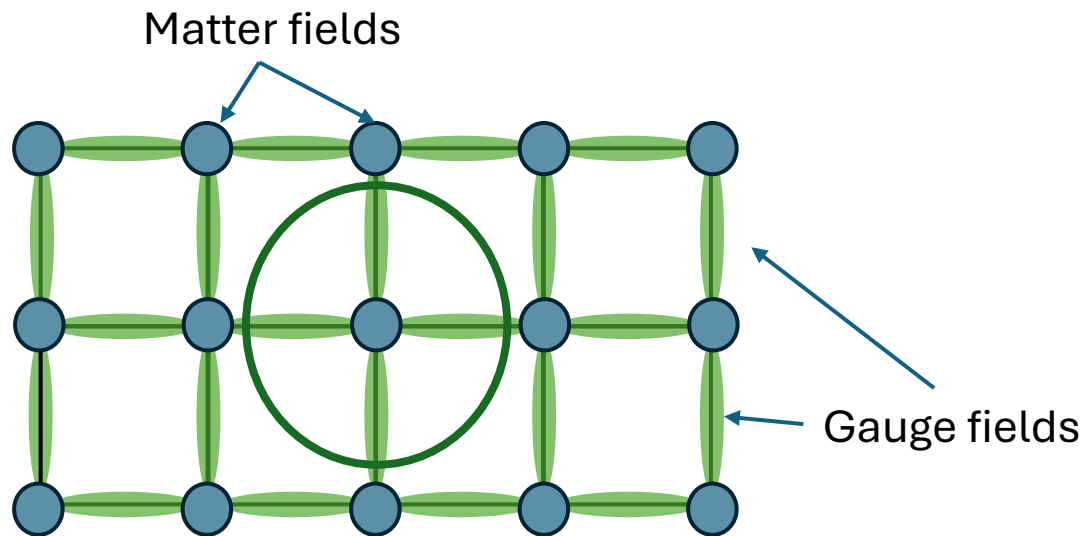

Local symmetry

$$U(1): \nabla \cdot \mathbf{E} = -\rho$$

$$\text{Lattice} \Rightarrow \sum_k (E_{\mathbf{r}+\mathbf{e}_k} - E_{\mathbf{r}-\mathbf{e}_k}) + \psi_{\mathbf{r}}^\dagger \psi_{\mathbf{r}} = 0$$

Gauge group  $G$

$$\Theta_{\mathbf{r}}(g) H \Theta_{\mathbf{r}}^\dagger(g) = H \quad \forall \mathbf{r} \in \mathbb{Z}^d, \forall g \in G$$

**Extensive number of symmetries**

## Local symmetries to restrict to physical states?

Do: smaller Hilbert space, possibly nonlocal Hamiltonian, multi-body interactions

Don't: larger Hilbert space, local Hamiltonian, gauge symmetry breaking

$$H = \begin{bmatrix} \text{Phys} & 0 \\ 0 & \text{non Phys} \end{bmatrix} \xrightarrow{+\text{errors}} \tilde{H} = \begin{bmatrix} \text{Phys} & \cdot & \cdot & \cdot \\ \cdot & \cdot & \cdot & \cdot \\ \cdot & \cdot & \cdot & \cdot \\ \cdot & \cdot & \cdot & \text{non Phys} \end{bmatrix}$$

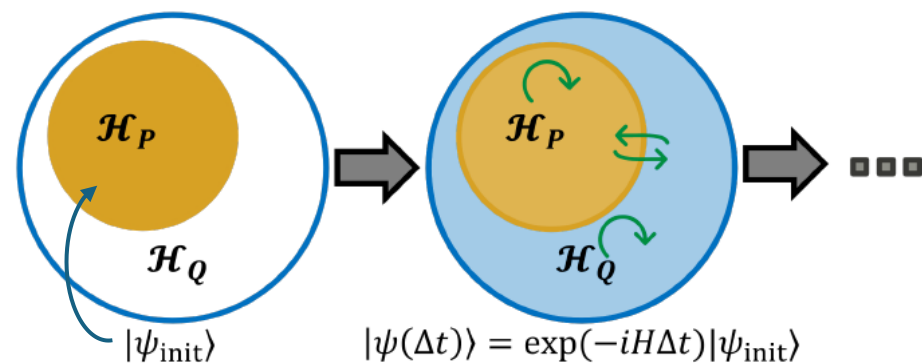

# Quantum simulations of lattice gauge theories

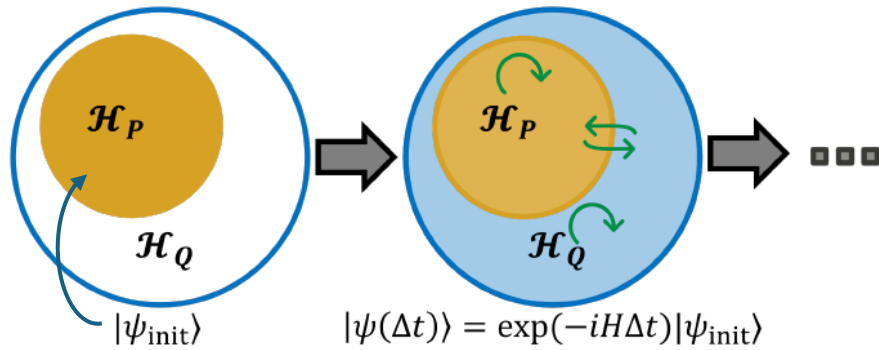

## How do we detect and suppress errors?

Qubits, abelian LGT:

Post-selection

Engineered dissipation

Effective Hamiltonian

Nonabelian LGT:

**Local symmetry generators do not commute**

Post-selection?

# Quantum simulations of lattice gauge theories

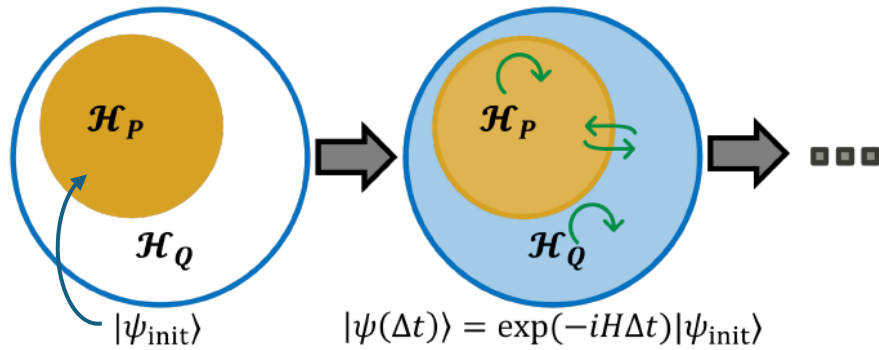

## How do we detect and suppress errors?

Qubits, abelian LGT:

Post-selection

Engineered dissipation

Effective Hamiltonian

Nonabelian LGT:

**Local symmetry generators do not commute**

Post-selection?

Why post-selection?

- Works with any error channel
- Building block for error correction



1. **Dynamical post-selection**
2. **Post-processed symmetry verification**

# Quantum simulations of lattice gauge theories

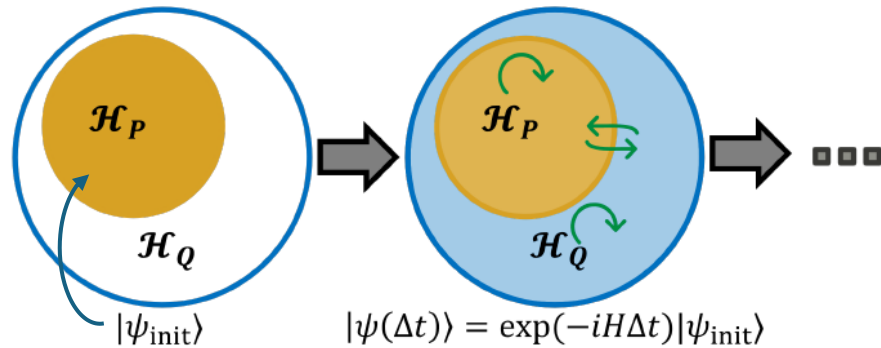

## How do we detect and suppress errors?

Qubits, abelian LGT:

Post-selection

Engineered dissipation

Effective Hamiltonian

Nonabelian LGT:

**Local symmetry generators do not commute**

Post-selection?

## Monitored LGT

- ? Interplay between unitary dynamics and measurements
- ? Trajectory statistics with different measurement schemes
- ? Conditional operations  $\Rightarrow$  towards error-corrected simulations
- ? Measurement-based control for qudits

## Why post-selection?

- Works with any error channel
- Building block for error correction

1. **Dynamical post-selection**
2. **Post-processed symmetry verification**

# Dynamical post-selection: warmup on $\mathbb{Z}_2$

Z2 LGT in one dimension (Fermionic matter + JW)

$$\hat{H}_0 = -J \sum_n (\sigma_n^+ \tau_{n,n+1}^z \sigma_n^- + \text{h.c.}) + \mu \sum_n (-1)^n \sigma_n^z - f \sum_n \tau_{n,n+1}^x$$

Local gauge charge  $\hat{G}_n = -\tau_{n-1,n}^x \sigma_n^z \tau_{n,n+1}^x \quad [\hat{H}_0, \hat{G}_n] = 0 \quad \forall n$

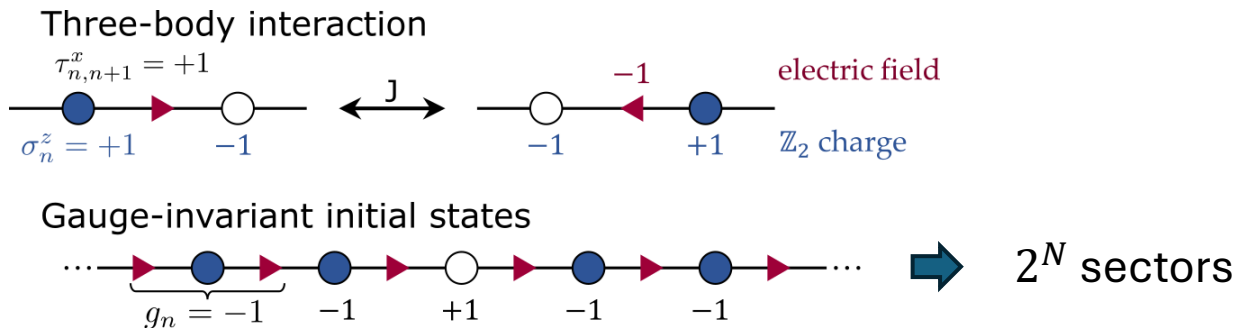

# Dynamical post-selection: warmup on $\mathbb{Z}_2$

Z2 LGT in one dimension (Fermionic matter + JW)

$$\hat{H}_0 = -J \sum_n (\sigma_n^+ \tau_{n,n+1}^z \sigma_n^- + \text{h.c.}) + \mu \sum_n (-1)^n \sigma_n^z - f \sum_n \tau_{n,n+1}^x$$

Local gauge charge  $\hat{G}_n = -\tau_{n-1,n}^x \sigma_n^z \tau_{n,n+1}^x \quad [\hat{H}_0, \hat{G}_n] = 0 \quad \forall n$

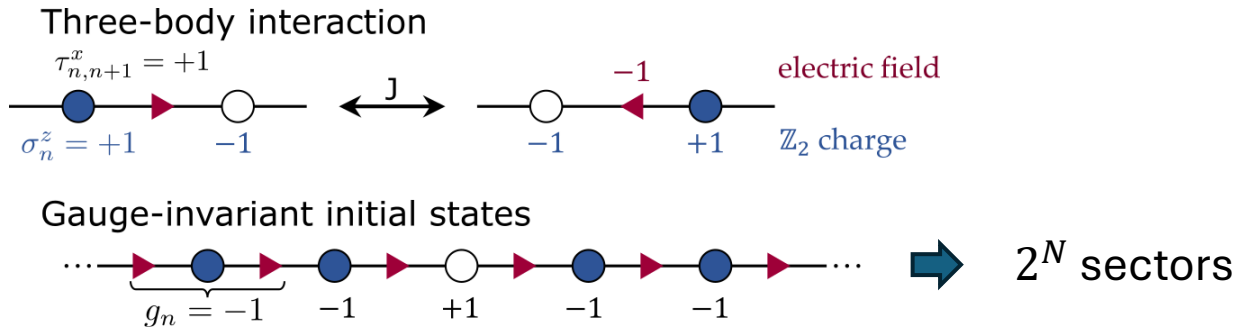

Gauge-symmetry breaking coherent error

$$\hat{H}_{\text{err}} = \lambda \sum_n (\sigma_n^+ \sigma_{n+1}^- + \text{h.c.}) + \lambda \sum_n \tau_{n,n+1}^z$$

$$[\hat{H}_{\text{err}}, \hat{G}_n] \neq 0$$

# Dynamical post-selection: warmup on $\mathbb{Z}_2$

Z2 LGT in one dimension (Fermionic matter + JW)

$$\hat{H}_0 = -J \sum_n (\sigma_n^+ \tau_{n,n+1}^z \sigma_n^- + \text{h.c.}) + \mu \sum_n (-1)^n \sigma_n^z - f \sum_n \tau_{n,n+1}^x$$

Local gauge charge  $\hat{G}_n = -\tau_{n-1,n}^x \sigma_n^z \tau_{n,n+1}^x$       $[\hat{H}_0, \hat{G}_n] = 0 \quad \forall n$

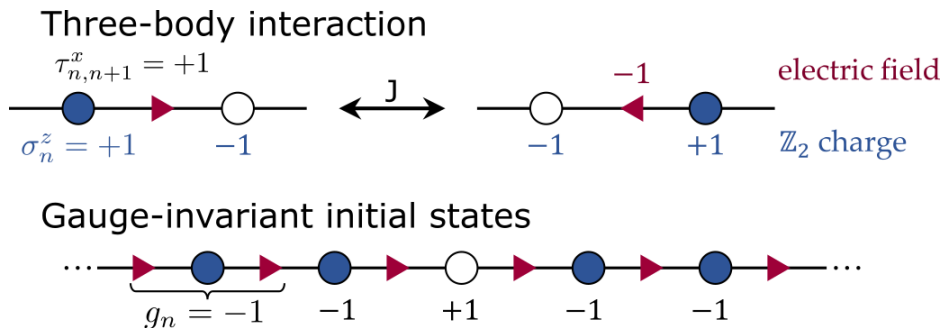

Gauge-symmetry breaking coherent error

$$\hat{H}_{\text{err}} = \lambda \sum_n (\sigma_n^+ \sigma_{n+1}^- + \text{h.c.}) + \lambda \sum_n \tau_{n,n+1}^z$$

$[\hat{H}_{\text{err}}, \hat{G}_n] \neq 0$

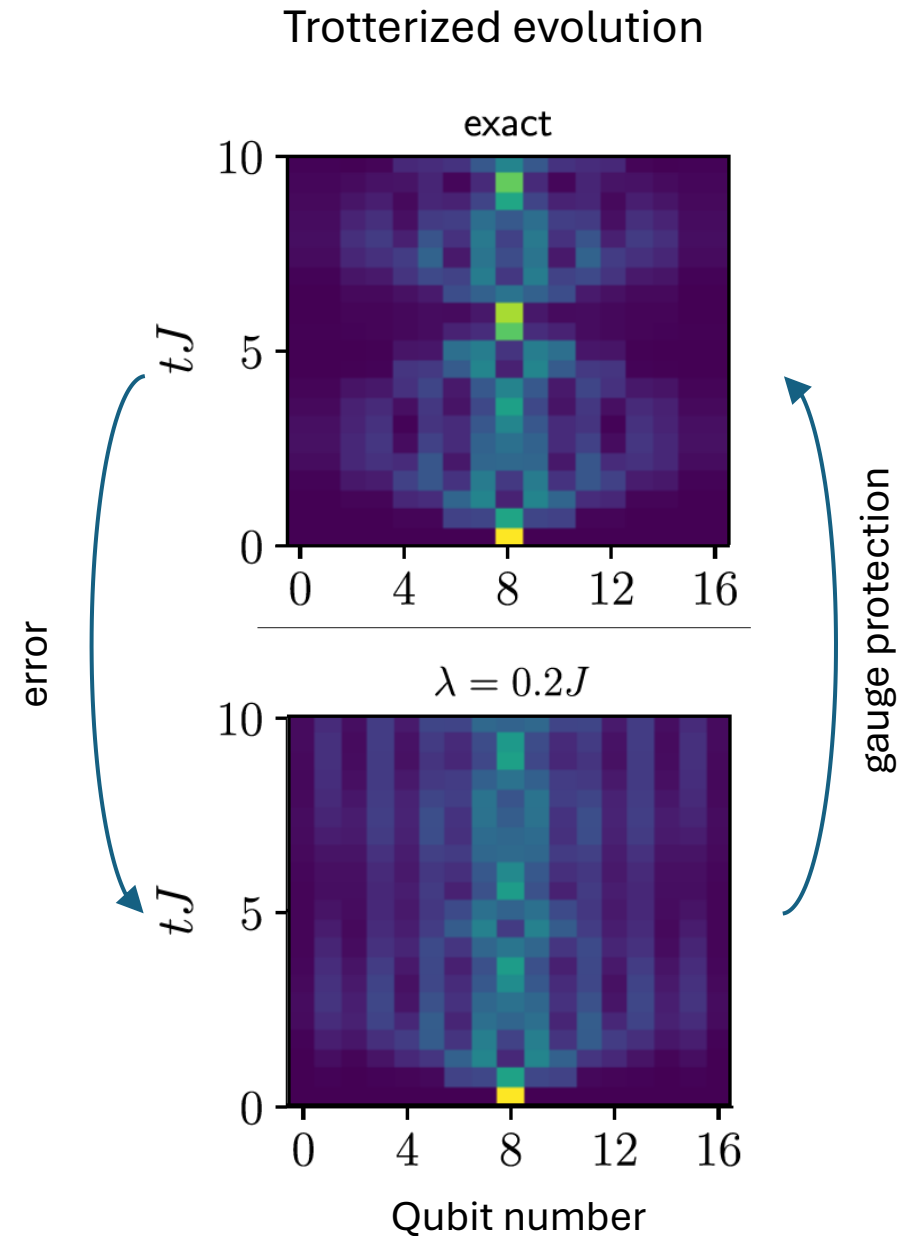

# Measurement-induced gauge protection in digital quantum simulations

## Dynamical post-selection approach

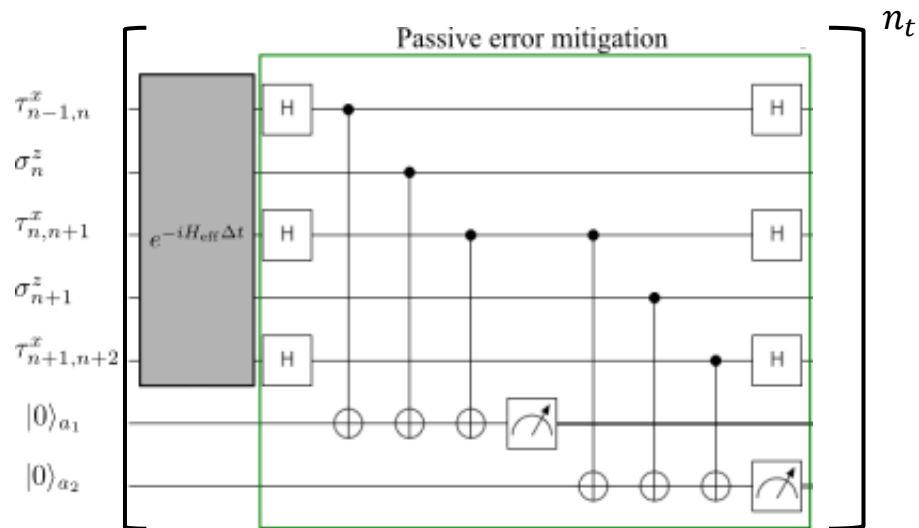

- At each Trotter step  $\hat{G}_n$  is encoded in an ancillary qubit
- Requires  $O(N)$  ancilla qubits
- No reset of  $|a\rangle$

# Measurement-induced gauge protection in digital quantum simulations

## Dynamical post-selection approach

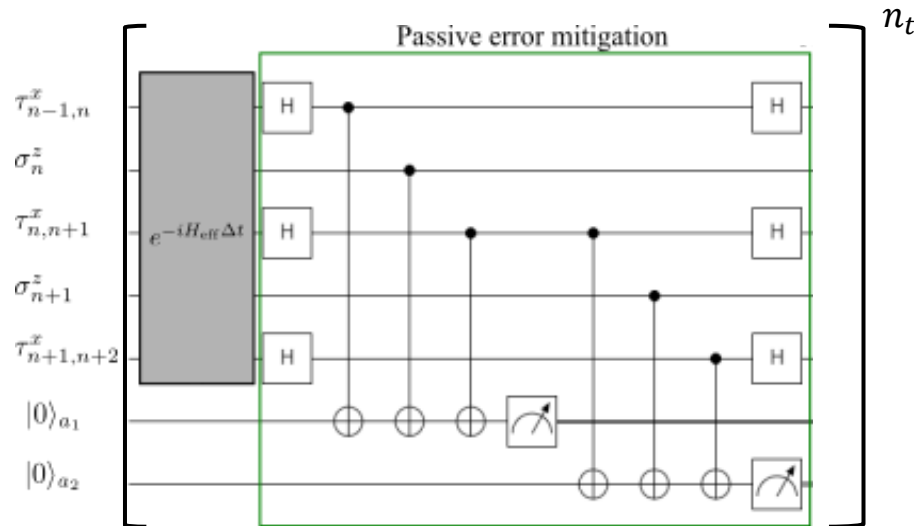

$$|\psi(t)\rangle = |\psi\rangle_{\text{phys}} \Rightarrow |\psi(t + \Delta t)\rangle = \alpha|\psi\rangle_{\text{phys}} + \beta|\psi\rangle_{\text{np}}$$

Coupling with the ancilla  $|a\rangle$

$$|\psi, a\rangle = \alpha|0\rangle_a|\psi\rangle_{\text{phys}} + \beta|1\rangle_b|\psi\rangle_{\text{np}}$$

Measure  $|a\rangle$

$$|\tilde{\psi}(t + \Delta t)\rangle = \begin{cases} |\psi\rangle_{\text{phys}} & \text{with probability } \alpha^2 \rightarrow \text{keep} \\ |\psi\rangle_{\text{np}} & \text{with probability } \beta^2 \rightarrow \text{discard} \end{cases}$$

- At each Trotter step  $\hat{G}_n$  is encoded in an ancillary qubit
- Requires  $O(N)$  ancilla qubits
- No reset of  $|a\rangle$

# Measurement-induced gauge protection in digital quantum simulations

## Dynamical post-selection approach

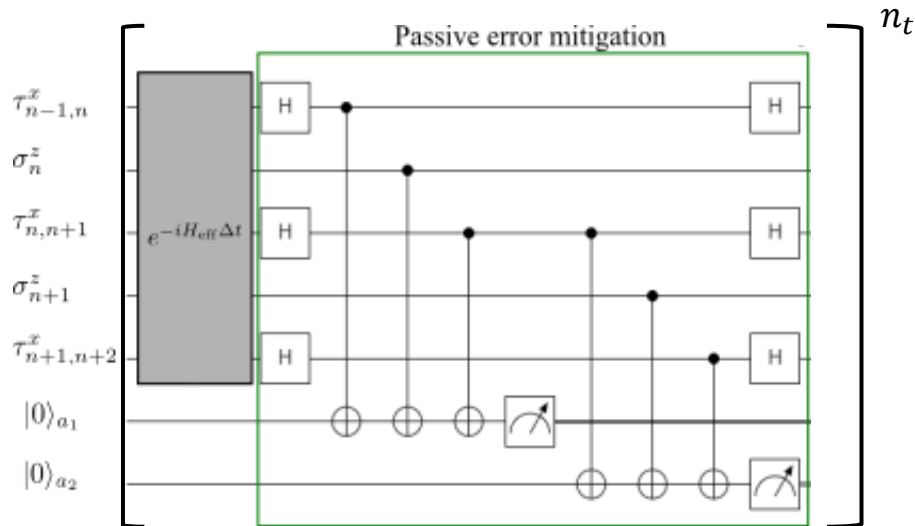

- At each Trotter step  $\hat{G}_n$  is encoded in an ancillary qubit
- Requires  $O(N)$  ancilla qubits
- No reset of  $|a\rangle$

$$|\psi(t)\rangle = |\psi\rangle_{\text{phys}} \Rightarrow |\psi(t + \Delta t)\rangle = \alpha|\psi\rangle_{\text{phys}} + \beta|\psi\rangle_{\text{np}}$$

Coupling with the ancilla  $|a\rangle$

$$|\psi, a\rangle = \alpha|0\rangle_a |\psi\rangle_{\text{phys}} + \beta|1\rangle_b |\psi\rangle_{\text{np}}$$

Measure  $|a\rangle$

$$|\tilde{\psi}(t + \Delta t)\rangle = \begin{cases} |\psi\rangle_{\text{phys}} & \text{with probability } \alpha^2 \rightarrow \text{keep} \\ |\psi\rangle_{\text{np}} & \text{with probability } \beta^2 \rightarrow \text{discard} \end{cases}$$



Equation for the density matrix in the “continuous time limit”

$$\dot{\rho} = -i\hbar[\hat{H}, \rho] + \frac{1}{2\tau} \sum_n \hat{G}_n \rho \hat{G}_n^\dagger - \frac{1}{2} \{ \hat{G}_n^\dagger \hat{G}_n, \rho \} = \mathcal{L}\rho$$

Time between measurements

# Measurement-induced gauge protection in digital quantum simulations

$$\dot{\rho} = -i\hbar[\hat{H}, \rho] + \gamma \sum_n \hat{G}_n \rho \hat{G}_n^\dagger - \frac{1}{2} \{ \hat{G}_n^\dagger \hat{G}_n, \rho \} = \mathcal{L}\rho$$

Possible implementations:

- Engineered dissipation [1]
- Random gauge transformations [2]
- Continuous measurements
- Continuous limit for DPS

[1] Stannigel et al. PRL **112** (2014)

[2] Lamm et al. arxiv:2005.12688

# Measurement-induced gauge protection in digital quantum simulations

$$\dot{\rho} = -i\hbar[\hat{H}, \rho] + \gamma \sum_n \hat{G}_n \rho \hat{G}_n^\dagger - \frac{1}{2} \{ \hat{G}_n^\dagger \hat{G}_n, \rho \} = \mathcal{L}\rho$$

Possible implementations:

- Engineered dissipation [1]
- Random gauge transformations [2]
- Continuous measurements
- Continuous limit for DPS

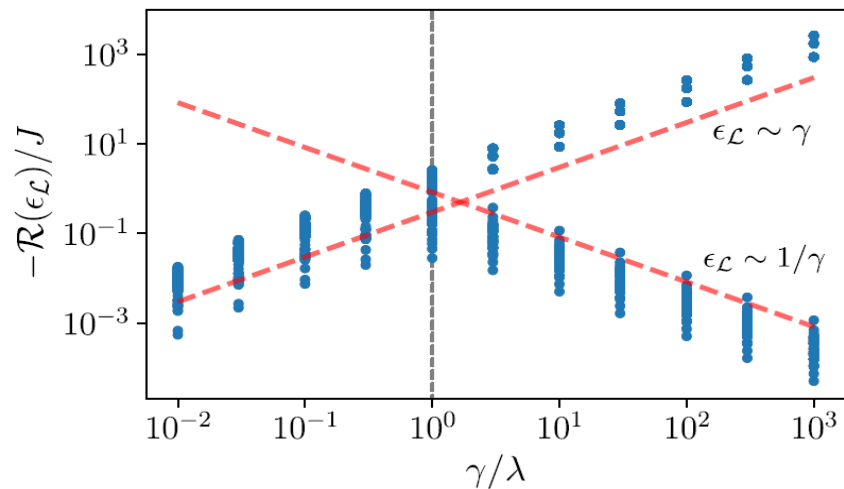

[1] Stannigel et al. PRL **112** (2014)

[2] Lamm et al. arxiv:2005.12688

# Measurement-induced gauge protection in digital quantum simulations

$$\dot{\rho} = -i\hbar[\hat{H}, \rho] + \gamma \sum_n \hat{G}_n \rho \hat{G}_n^\dagger - \frac{1}{2} \{ \hat{G}_n^\dagger \hat{G}_n, \rho \} = \mathcal{L}\rho$$

Possible implementations:

- Engineered dissipation [1]
- Random gage transformations [2]
- Continuous measurements
- Continuous limit for DPS

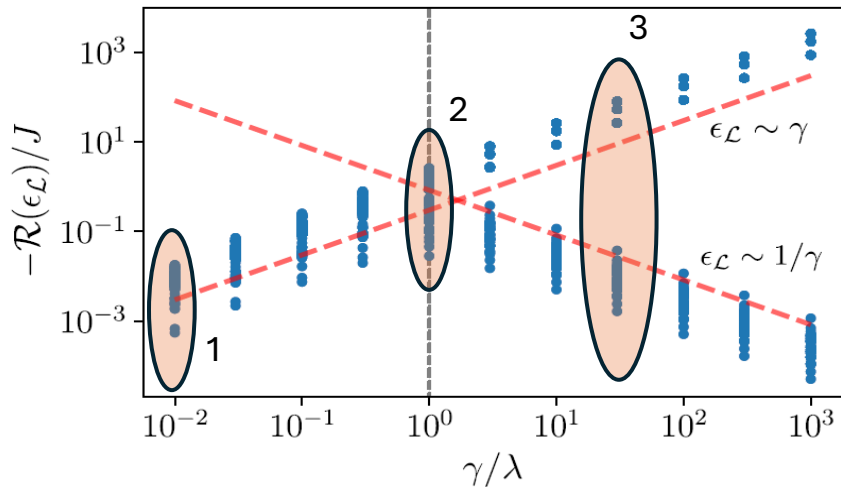

**Quantum Zeno transition between protected and chaotic phases**

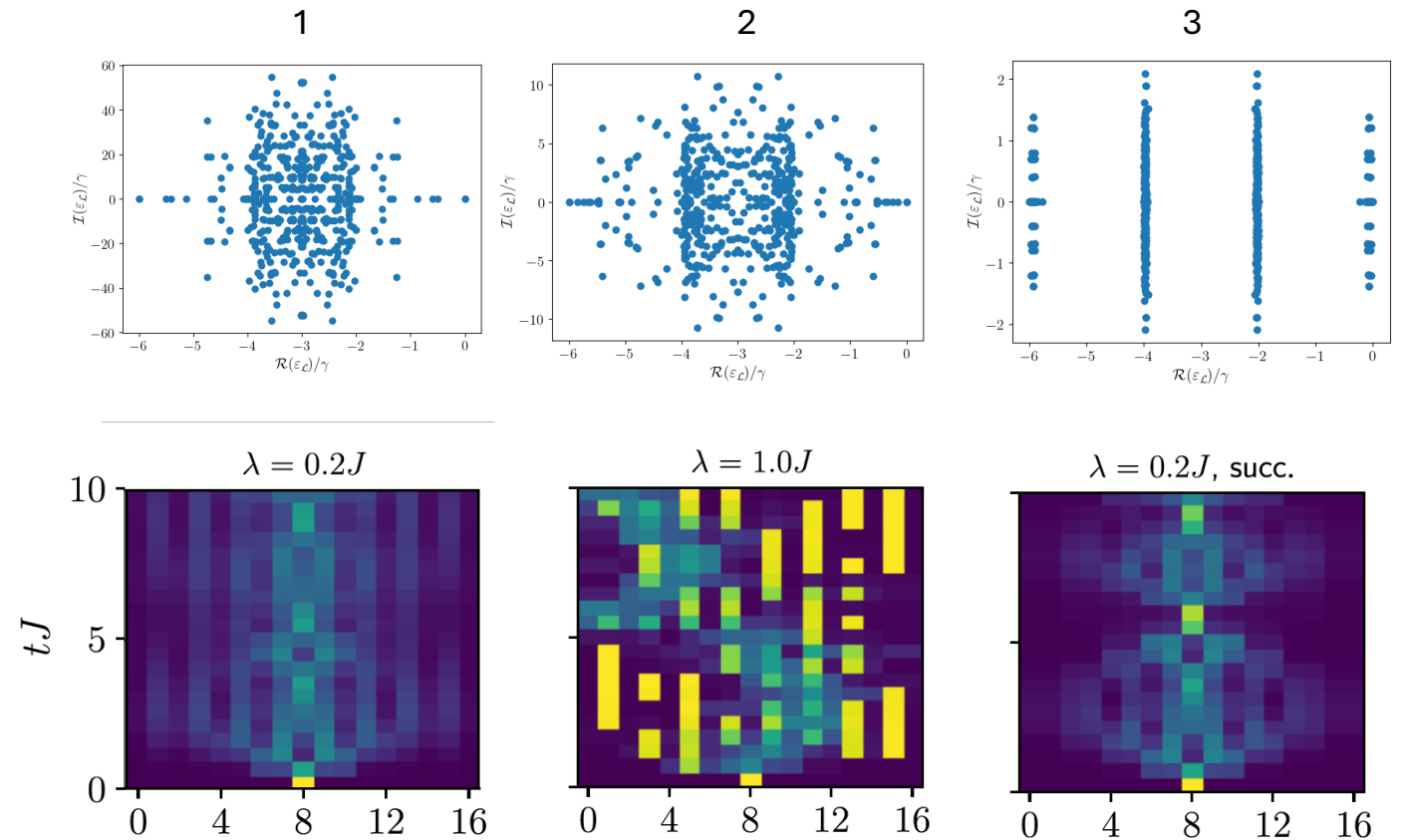

[1] Stannigel et al. PRL **112** (2014)

[2] Lamm et al. arxiv:2005.12688

# Measurement-induced gauge protection in digital quantum simulations

$$\dot{\rho} = -i\hbar[\hat{H}, \rho] + \gamma \sum_n \hat{G}_n \rho \hat{G}_n^\dagger - \frac{1}{2} \{ \hat{G}_n^\dagger \hat{G}_n, \rho \} = \mathcal{L}\rho$$

Possible implementations:

- Engineered dissipation [1]
- Random gage transformations [2]
- Continuous measurements
- Continuous limit for DPS

**Quantum Zeno transition between protected (QZP) and chaotic phases**

**Importance of unraveling: same ensemble average, different stochastic trajectories**

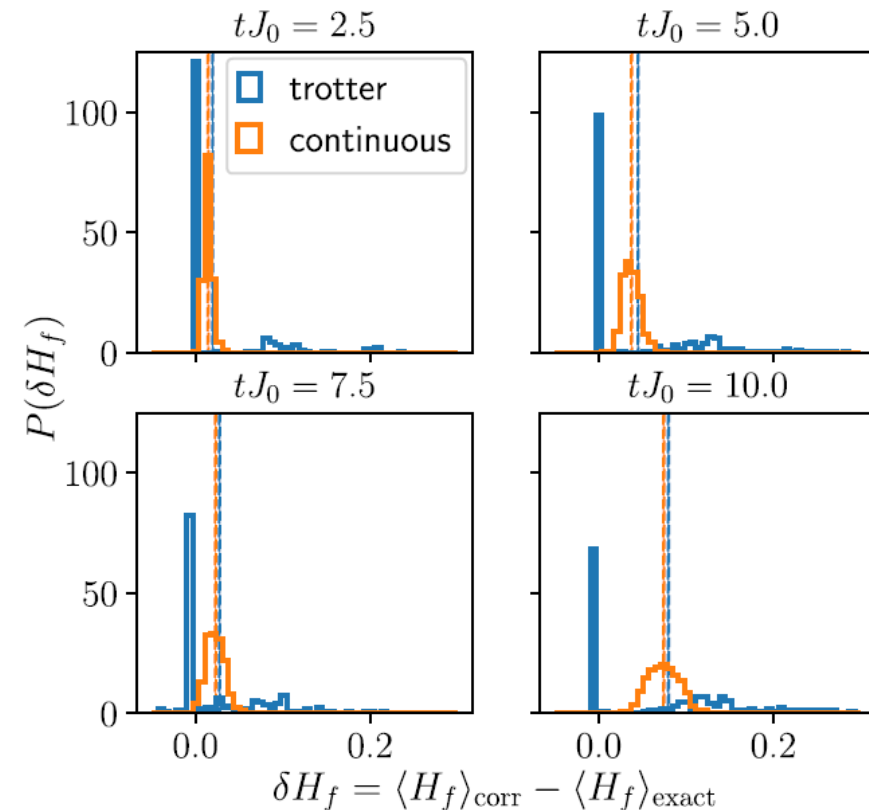

[1] Stannigel et al. PRL **112** (2014)

[2] Lamm et al. arxiv:2005.12688

# Measurement-induced gauge protection in digital quantum simulations

$$\dot{\rho} = -i\hbar[\hat{H}, \rho] + \gamma \sum_n \hat{G}_n \rho \hat{G}_n^\dagger - \frac{1}{2} \{ \hat{G}_n^\dagger \hat{G}_n, \rho \} = \mathcal{L}\rho$$

Possible implementations:

- Engineered dissipation [1]
- Random gage transformations [2]
- Continuous measurements
- Continuous limit for DPS

**Quantum Zeno transition between protected (QZP) and chaotic phases**

**Importance of unraveling: same ensemble average, different stochastic trajectories**

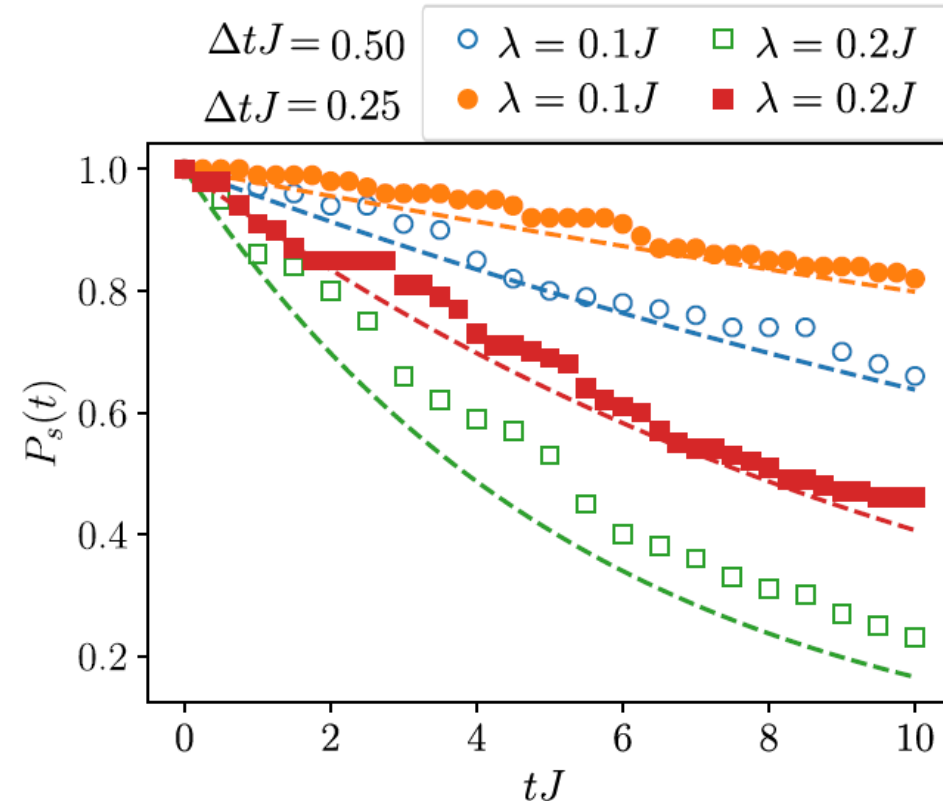

[1] Stannigel et al. PRL **112** (2014)

[2] Lamm et al. arxiv:2005.12688

# Nonabelian LGT: benchmark on $D_3$

## $D_3$ gauge symmetry group

- Smallest discrete nonabelian group  $\Rightarrow$  “fits” Ca trapped ion qudit platform\*
- Topological order and universal anyons

2+1 dimensional square lattice , pure gauge:

$$\hat{H}_0 = \boxed{-\frac{1}{g^2} \sum_p \mathcal{R} \left[ \text{Tr} \left( \hat{U}_{p_1}^j \hat{U}_{p_2}^j \hat{U}_{p_3}^{j\dagger} \hat{U}_{p_4}^{j\dagger} \right) \right]} + \hat{H}_E$$

$\hat{H}_B$

$$[\hat{H}_B, \hat{H}_E] \neq 0$$

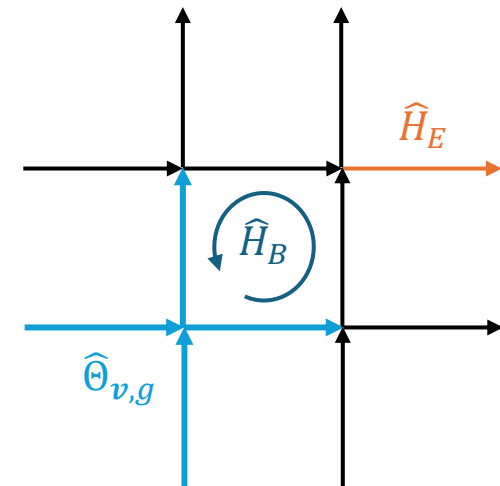
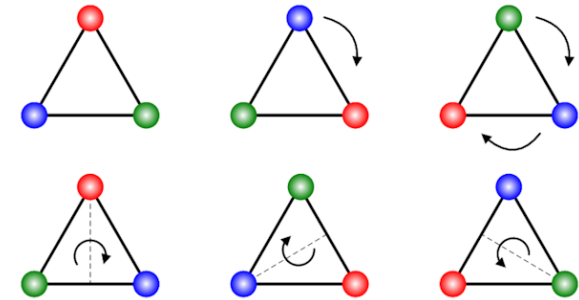

# Nonabelian LGT: benchmark on $D_3$

## $D_3$ gauge symmetry group

- Smallest discrete nonabelian group  $\Rightarrow$  “fits” Ca trapped ion qudit platform\*.
- Topological order and universal anyons

2+1 dimensional square lattice , pure gauge:

$$\hat{H}_0 = \underbrace{-\frac{1}{g^2} \sum_p \mathcal{R} \left[ \text{Tr} \left( \hat{U}_{p_1}^j \hat{U}_{p_2}^j \hat{U}_{p_3}^{j\dagger} \hat{U}_{p_4}^{j\dagger} \right) \right]}_{\hat{H}_B} + \hat{H}_E$$

$$[\hat{H}_B, \hat{H}_E] \neq 0$$

Gauge transformation on vertex  $v$

$$\hat{\Theta}_{v,g} = \hat{\Theta}_{3,g}^L \hat{\Theta}_{4,g}^L \hat{\Theta}_{1,g}^R \hat{\Theta}_{2,g}^R, \quad [\hat{\Theta}_{v,g}, \hat{\Theta}_{v,h}] \neq 0 \text{ but } \Pi_s [\hat{\Theta}_{v,g}, \hat{\Theta}_{v,h}] \Pi_s = 0$$

$$\hat{\Theta}_{v,g} |\psi_{\text{phys}}\rangle = |\psi_{\text{phys}}\rangle \quad \forall g \in G, v$$

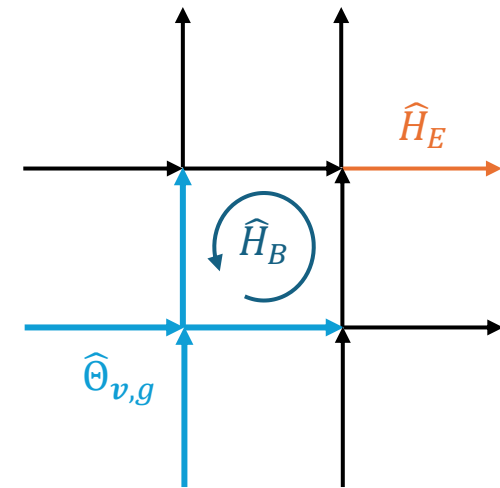
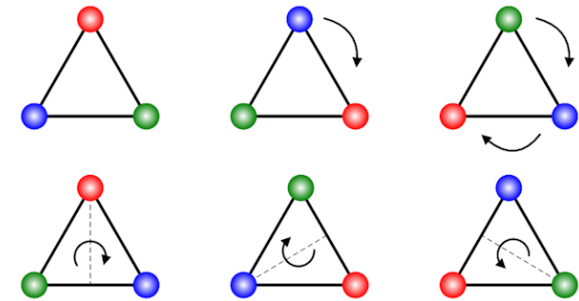

# Nonabelian LGT: benchmark on $D_3$

## $D_3$ gauge symmetry group

- Smallest discrete nonabelian group  $\Rightarrow$  “fits” Ca trapped ion qudit platform[1].
- Topological order and universal anyons

2+1 dimensional square lattice , pure gauge:

$$\hat{H}_0 = \underbrace{-\frac{1}{g^2} \sum_p \mathcal{R} \left[ \text{Tr} \left( \hat{U}_{p_1}^j \hat{U}_{p_2}^j \hat{U}_{p_3}^{j\dagger} \hat{U}_{p_4}^{j\dagger} \right) \right]}_{\hat{H}_B} + \hat{H}_E$$

$$[\hat{H}_B, \hat{H}_E] \neq 0$$

Gauge transformation on vertex  $v$

$$\hat{\Theta}_{v,g} = \hat{\Theta}_{3,g}^L \hat{\Theta}_{4,g}^L \hat{\Theta}_{1,g}^R \hat{\Theta}_{2,g}^R, \quad [\hat{\Theta}_{v,g}, \hat{\Theta}_{v,h}] \neq 0$$

$$\hat{\Theta}_{v,g} |\psi_{\text{phys}}\rangle = |\psi_{\text{phys}}\rangle \quad \forall g \in G, v$$

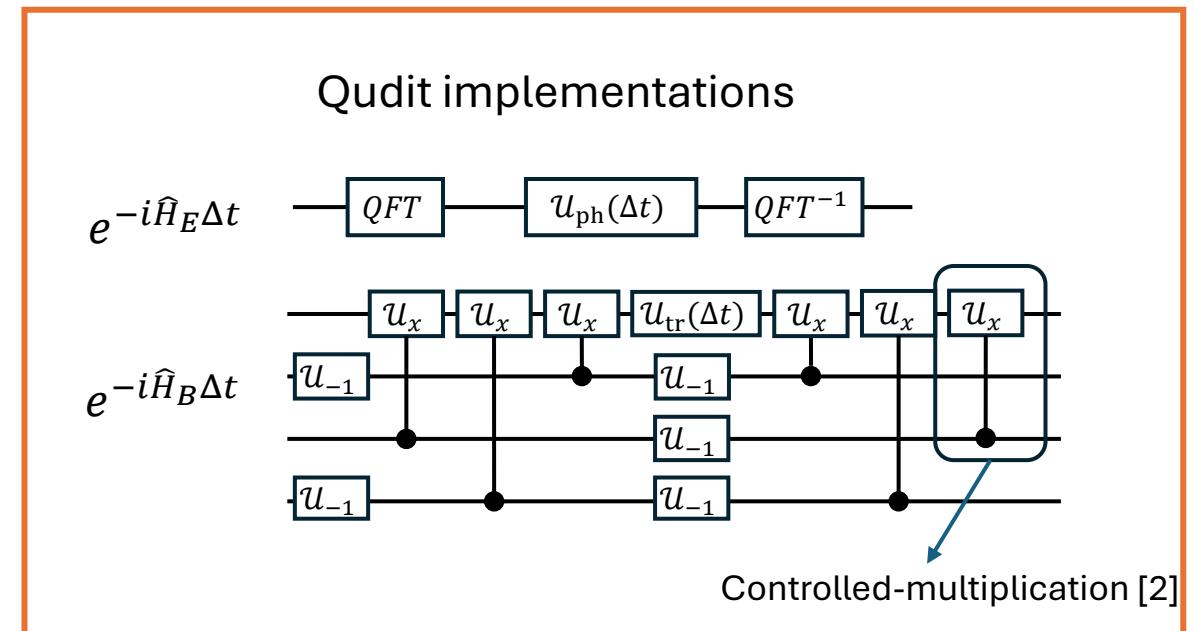
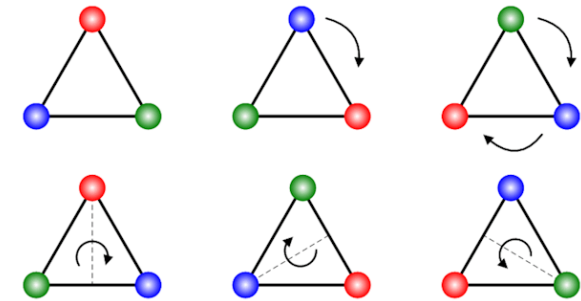

[1] Ringbauer et al, Nat Phys 18 (2022)

[2] González-Cuadra et al. PRL 129 (2022)

## $D_3$ Dynamical post-selection

What do we measure?

Computational basis

- ✓ Plaquette operator
- ✗ Local gauge charge

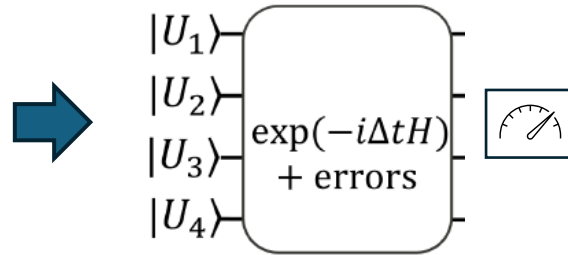

## $D_3$ Dynamical post-selection

What do we measure?

Computational basis

- ✓ Plaquette operator
- ✗ Local gauge charge

Eigenbasis of  $\hat{\Theta}_{v,g}$

- ✗ Plaquette operator
- ✗ Gauge transformations do not commute
- ✓ Local gauge charge

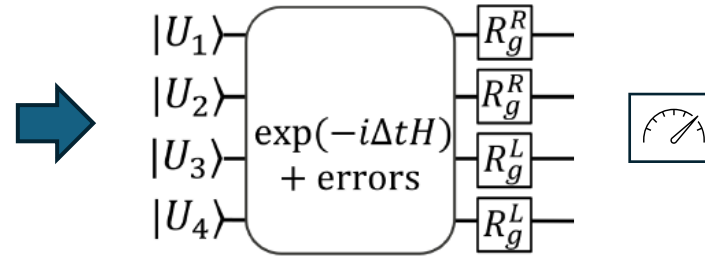

# $D_3$ Dynamical post-selection

What do we measure?

Computational basis

- ✓ Plaque operator
- ✗ Local gauge charge

Eigenbasis of  $\hat{\Theta}_{v,g}$

- ✗ Plaque operator
- ✗ Gauge transformations do not commute
- ✓ Local gauge charge

Digital post-selection

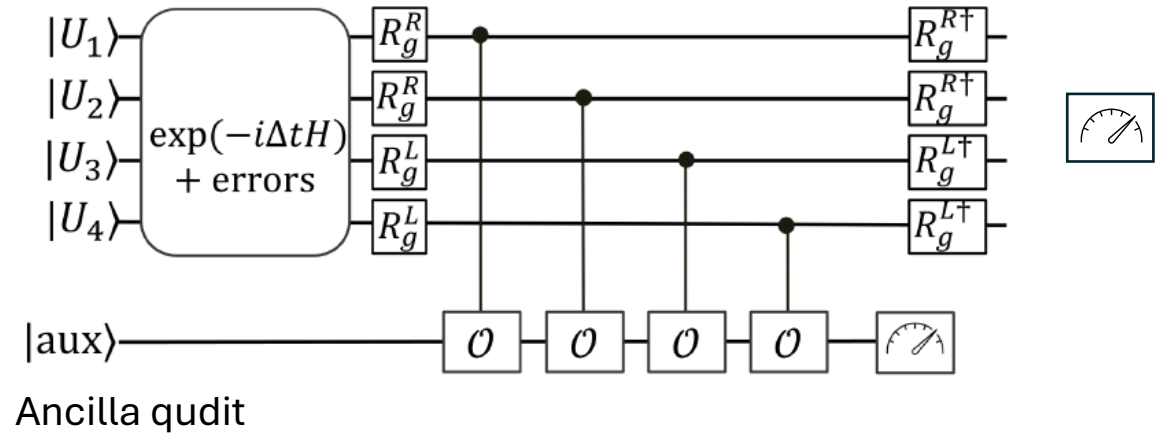

# $D_3$ Dynamical post-selection

What do we measure?

Computational basis

- ✓ Plaquette operator
- ✗ Local gauge charge

Eigenbasis of  $\hat{\Theta}_{v,g}$

- ✗ Plaquette operator
- ✗ Gauge transformations do not commute
- ✓ Local gauge charge

Digital post-selection

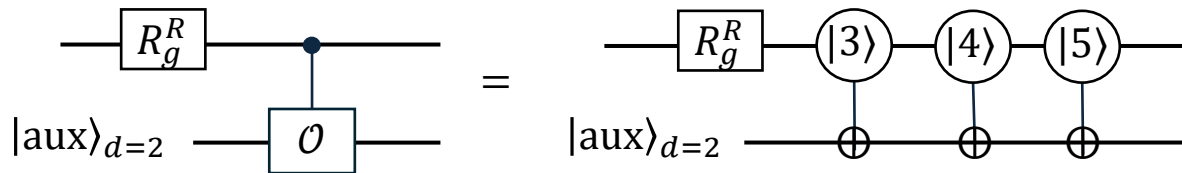
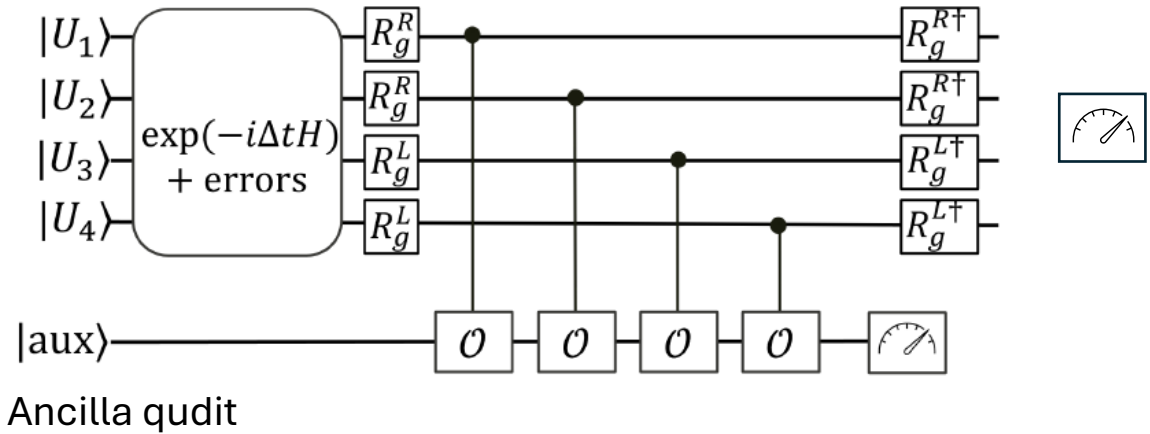

$g$  is a reflection

$$R_g^{R\dagger} \hat{\Theta}_g^R R_g^R = \text{diag}(1, 1, 1, -1, -1, -1)$$

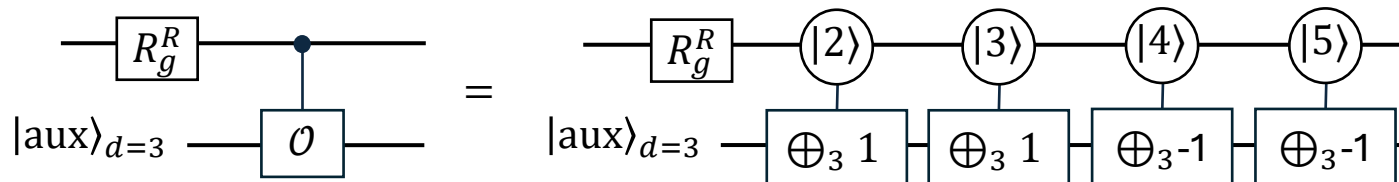

$g$  is a rotation

$$R_g^{R\dagger} \hat{\Theta}_g^R R_g^R = \text{diag}(1, 1, e^{i2\pi/3}, e^{i2\pi/3}, e^{-i2\pi/3}, e^{-i2\pi/3})$$

# $D_3$ post-Processed Symmetry Verification (PSV)

$\Pi_s$  = projector on gauge-symmetric sector

$\rho$  = density matrix after noisy evolution

$$\rho_s = \frac{\Pi_s \rho \Pi_s}{\text{Tr}[\Pi_s \rho]}$$

Symmetry-projected expectation value of gauge-invariant observable

$$\text{Tr}(O \rho_s) = \frac{\text{Tr}[O \Pi_s \rho \Pi_s]}{\text{Tr}[\Pi_s \rho]} = \frac{\text{Tr}[O_s \rho]}{\text{Tr}[\Pi_s \rho]}, \quad \text{with } O_s = \Pi_s O \Pi_s = \Pi_s O$$

# $D_3$ post-Processed Symmetry Verification (PSV)

$\Pi_s$  = projector on gauge-symmetric sector

$\rho$  = density matrix after noisy evolution

$$\rho_s = \frac{\Pi_s \rho \Pi_s}{\text{Tr}[\Pi_s \rho]}$$

Symmetry-projected expectation value of gauge-invariant observable

$$\text{Tr}(O \rho_s) = \frac{\text{Tr}[O \Pi_s \rho \Pi_s]}{\text{Tr}[\Pi_s \rho]} = \frac{\text{Tr}[O_s \rho]}{\text{Tr}[\Pi_s \rho]}, \quad \text{with } O_s = \Pi_s O \Pi_s = \Pi_s O$$

Discrete groups

$$\Pi_s = \prod_{v \in V} \left[ \frac{1}{|G|} \sum_{g \in G} \Theta_{g,v} \right] = \frac{1}{|G|^{n_v}} \sum_{g \in G^{n_v}} \prod_{v \in V} \Theta_{g_v,v}$$

# $D_3$ post-Processed Symmetry Verification (PSV)

$\Pi_s$  = projector on gauge-symmetric sector

$\rho$  = density matrix after noisy evolution

$$\rho_s = \frac{\Pi_s \rho \Pi_s}{\text{Tr}[\Pi_s \rho]}$$

Symmetry-projected expectation value of gauge-invariant observable

$$\text{Tr}(O \rho_s) = \frac{\text{Tr}[O \Pi_s \rho \Pi_s]}{\text{Tr}[\Pi_s \rho]} = \frac{\text{Tr}[O_s \rho]}{\text{Tr}[\Pi_s \rho]}, \quad \text{with } O_s = \Pi_s O \Pi_s = \Pi_s O$$

Discrete groups

$$\Pi_s = \prod_{v \in V} \left[ \frac{1}{|G|} \sum_{g \in G} \Theta_{g,v} \right] = \frac{1}{|G|^{n_v}} \sum_{g \in G^{n_v}} \prod_{v \in V} \Theta_{g_v, v}$$

$$\text{Tr}(O \rho_s) = \frac{\text{Tr}[O \Pi_s \rho]}{\text{Tr}[\Pi_s \rho]} = \frac{\sum_{g \in G^{n_v}} \text{Tr}[\rho O \Pi_{v \in V} \Theta_{g_v, v}]}{\sum_{g \in G^{n_v}} \text{Tr}[\rho \Pi_{v \in V} \Theta_{g_v, v}]}$$

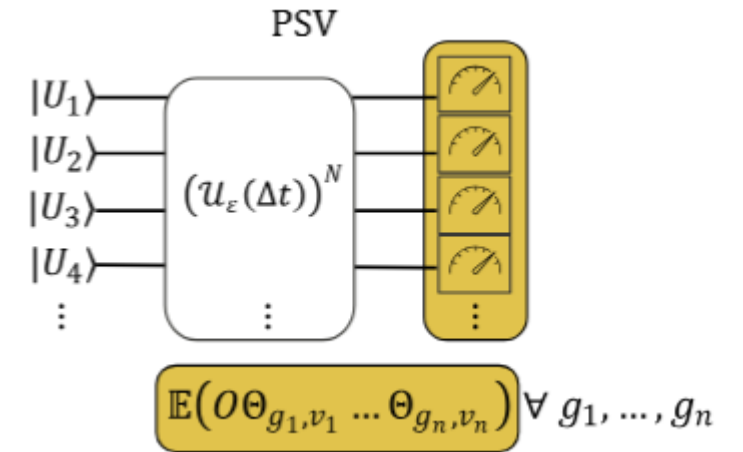

Effective group symmetrization  
by averaging over multiple  
observables

# $D_3$ post-Processed Symmetry Verification (PSV)

$\Pi_s$  = projector on gauge-symmetric sector

$\rho$  = density matrix after noisy evolution

$$\rho_s = \frac{\Pi_s \rho \Pi_s}{\text{Tr}[\Pi_s \rho]}$$

Symmetry-projected expectation value of gauge-invariant observable

$$\text{Tr}(O \rho_s) = \frac{\text{Tr}[O \Pi_s \rho \Pi_s]}{\text{Tr}[\Pi_s \rho]} = \frac{\text{Tr}[O_s \rho]}{\text{Tr}[\Pi_s \rho]}, \quad \text{with } O_s = \Pi_s O \Pi_s = \Pi_s O$$

Discrete groups

$$\Pi_s = \prod_{v \in V} \left[ \frac{1}{|G|} \sum_{g \in G} \Theta_{g,v} \right] = \frac{1}{|G|^{n_v}} \sum_{g \in G^{n_v}} \prod_{v \in V} \Theta_{g_v, v}$$

$$\text{Tr}(O \rho_s) = \frac{\text{Tr}[O \Pi_s \rho]}{\text{Tr}[\Pi_s \rho]} = \frac{\sum_{g \in G^{n_v}} \text{Tr}[\rho O \prod_{v \in V} \Theta_{g_v, v}]}{\sum_{g \in G^{n_v}} \text{Tr}[\rho \prod_{v \in V} \Theta_{g_v, v}]}$$

Ugly sum with exponentially many terms

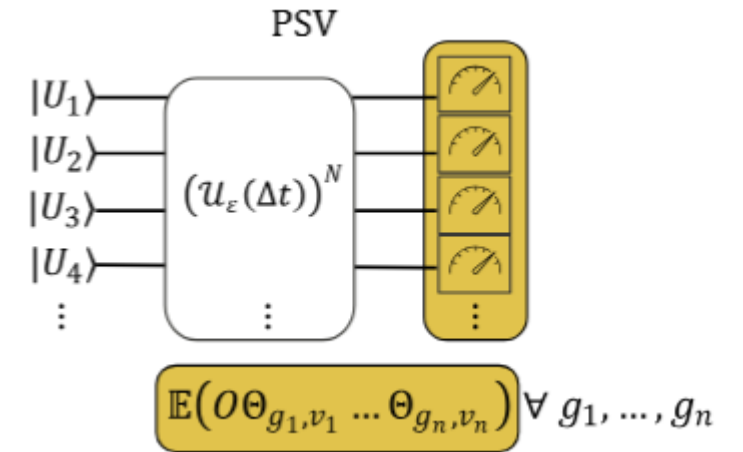

Effective group symmetrization by averaging over multiple observables

Operator dressed with local gauge transformation

# Numerical Results

Two plaquettes with PBC

$$\dim \mathcal{H}_{\text{tot}} = 6^4 = 1296$$

$$\dim \mathcal{H}_{\text{phys}} = 49$$

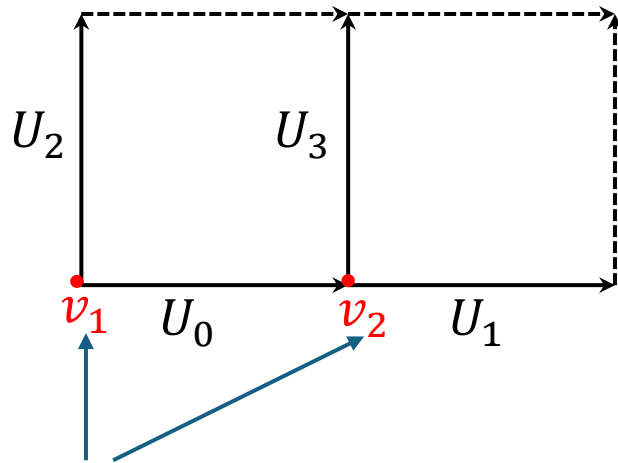

Two vertices

$$\widehat{\Theta}_{v_1, g} = \widehat{\Theta}_{0, g}^L \widehat{\Theta}_{2, g}^L \widehat{\Theta}_{0, g}^R \widehat{\Theta}_{1, g}^R$$

$$\widehat{\Theta}_{v_2, g} = \widehat{\Theta}_{1, g}^L \widehat{\Theta}_{3, g}^L \widehat{\Theta}_{0, g}^R \widehat{\Theta}_{3, g}^R$$

Noise model: random unitaries close to the identity

$$|\psi(t)\rangle = \exp(-iHt) |\psi(0)\rangle$$

$$\cong \left[ \mathcal{U}_{\varepsilon(\gamma)} \exp\left(-\frac{iH_E t}{N}\right) \exp\left(-\frac{iH_B t}{N}\right) \right]^N |\psi(0)\rangle$$

$$\widehat{H}_0 = -\frac{1}{g^2} \sum_p \mathcal{R} \left[ \text{Tr} \left( \widehat{U}_{p_1}^j \widehat{U}_{p_2}^j \widehat{U}_{p_3}^{j\dagger} \widehat{U}_{p_4}^{j\dagger} \right) \right] + \widehat{H}_E$$

# Numerical Results

Two plaquettes with PBC

$$\dim \mathcal{H}_{\text{tot}} = 6^4 = 1296$$

$$\dim \mathcal{H}_{\text{phys}} = 49$$

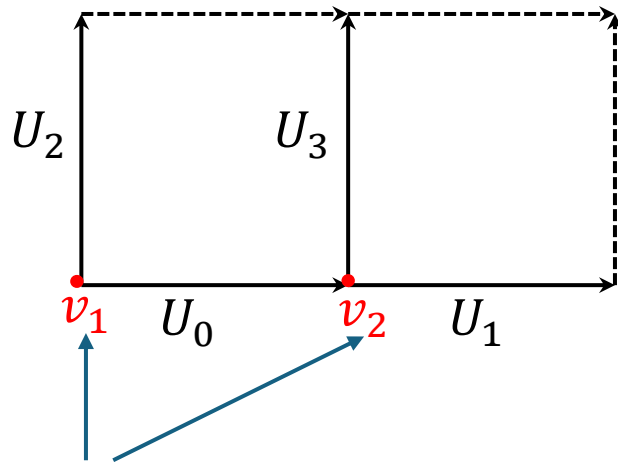

Two vertices

$$\widehat{\mathcal{O}}_{v_1, g} = \widehat{\mathcal{O}}_{0, g}^L \widehat{\mathcal{O}}_{2, g}^L \widehat{\mathcal{O}}_{0, g}^R \widehat{\mathcal{O}}_{1, g}^R$$

$$\widehat{\mathcal{O}}_{v_2, g} = \widehat{\mathcal{O}}_{1, g}^L \widehat{\mathcal{O}}_{3, g}^L \widehat{\mathcal{O}}_{0, g}^R \widehat{\mathcal{O}}_{3, g}^R$$

Noise model: random unitaries close to the identity

$$|\psi(t)\rangle = \exp(-iHt) |\psi(0)\rangle$$

$$\cong \left[ \mathcal{U}_{\varepsilon(\gamma)} \exp\left(-\frac{iH_E t}{N}\right) \exp\left(-\frac{iH_B t}{N}\right) \right]^N |\psi(0)\rangle$$

$$\widehat{H}_0 = -\frac{1}{g^2} \sum_p \mathcal{R} \left[ \text{Tr} \left( \widehat{U}_{p_1}^j \widehat{U}_{p_2}^j \widehat{U}_{p_3}^{j\dagger} \widehat{U}_{p_4}^{j\dagger} \right) \right] + \widehat{H}_E$$

Quench protocol:

- **DPS:** Each trotter step, measure **one** local charge
- **PSV:** 16 independent observables to sample

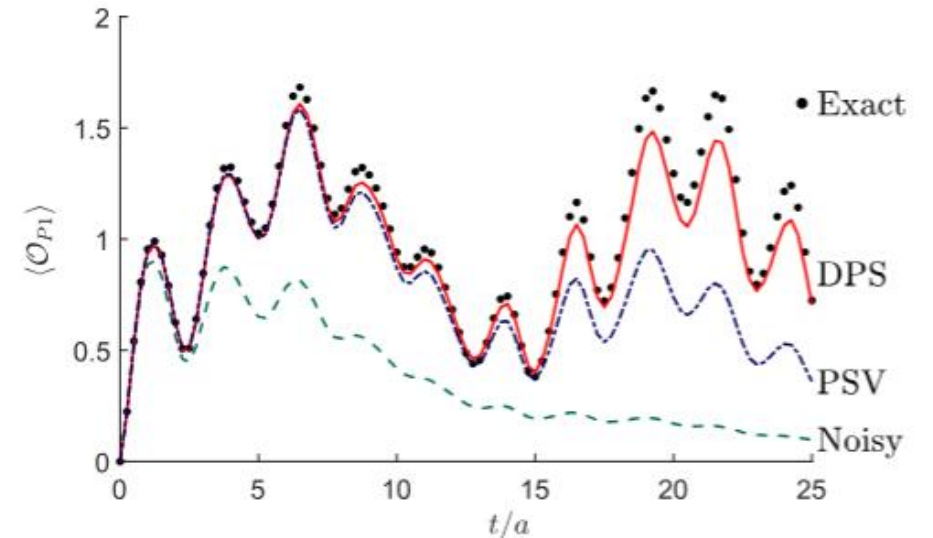

# Numerical Results

Two plaquettes with PBC

$$\dim \mathcal{H}_{\text{tot}} = 6^4 = 1296$$

$$\dim \mathcal{H}_{\text{phys}} = 49$$

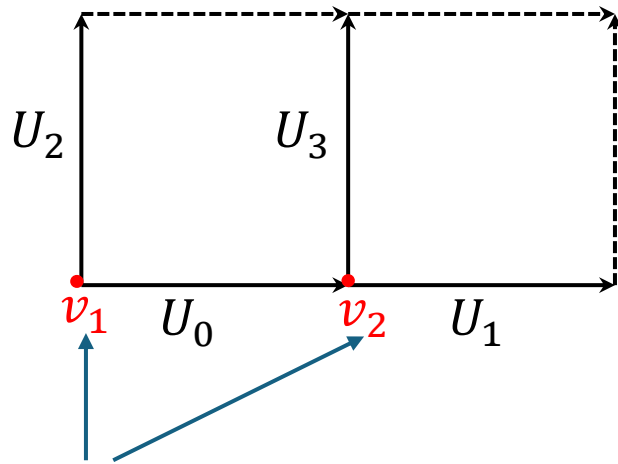

Two vertices

$$\widehat{\Theta}_{v_1, g} = \widehat{\Theta}_{0, g}^L \widehat{\Theta}_{2, g}^L \widehat{\Theta}_{0, g}^R \widehat{\Theta}_{1, g}^R$$

$$\widehat{\Theta}_{v_2, g} = \widehat{\Theta}_{1, g}^L \widehat{\Theta}_{3, g}^L \widehat{\Theta}_{0, g}^R \widehat{\Theta}_{3, g}^R$$

Quench protocol:

- **DPS:** Each trotter step, measure **one** local charge
- **PSV:** 16 independent observables to sample

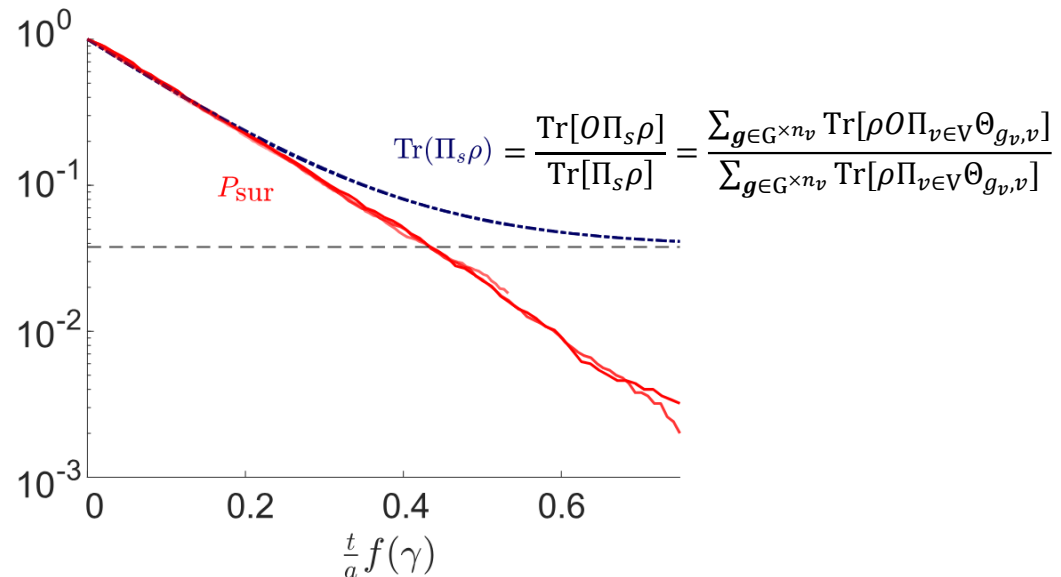
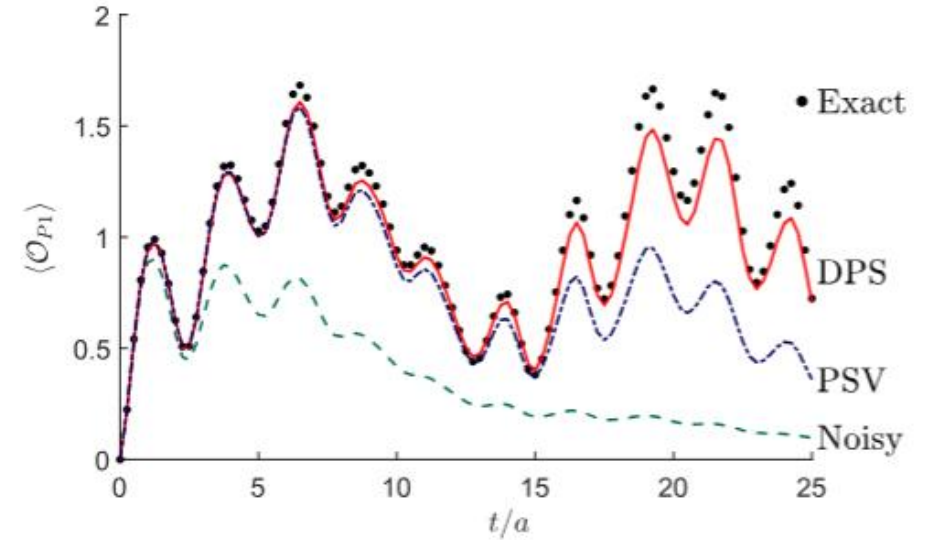

# Numerical Results

Two plaquettes with PBC

$$\dim \mathcal{H}_{\text{tot}} = 6^4 = 1296$$

$$\dim \mathcal{H}_{\text{phys}} = 49$$

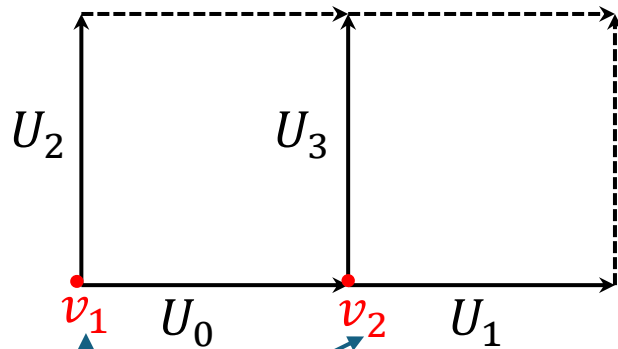

Two vertices

$$\widehat{\Theta}_{v_1, g} = \widehat{\Theta}_{0, g}^L \widehat{\Theta}_{2, g}^L \widehat{\Theta}_{0, g}^R \widehat{\Theta}_{1, g}^R$$

$$\widehat{\Theta}_{v_2, g} = \widehat{\Theta}_{1, g}^L \widehat{\Theta}_{3, g}^L \widehat{\Theta}_{0, g}^R \widehat{\Theta}_{3, g}^R$$

Quench protocol:

- **DPS:** Each trotter step, measure **one** local charge
- **PSV:** 16 independent observables to sample

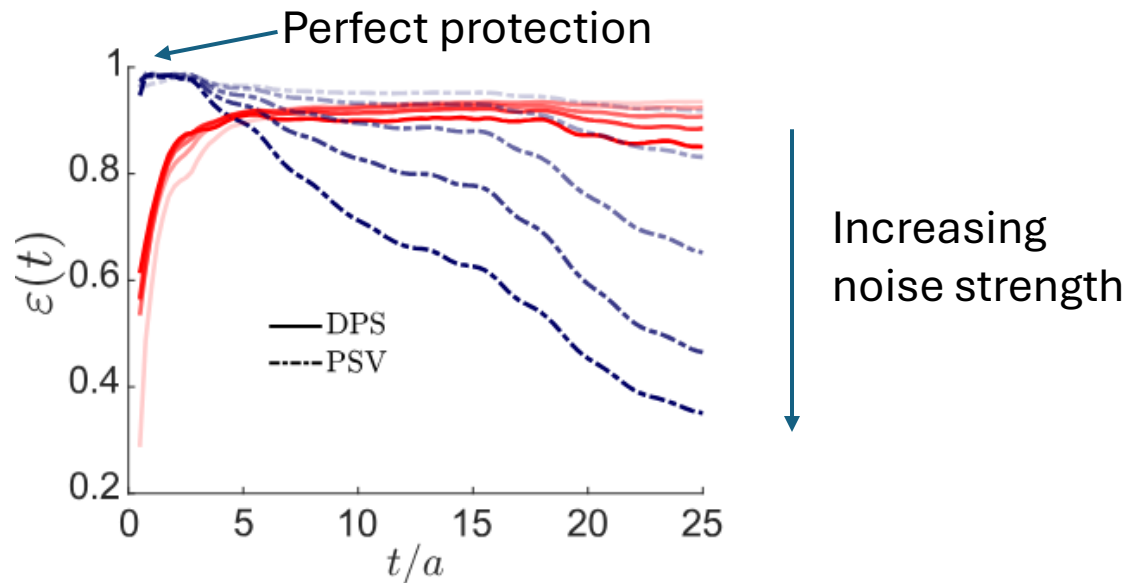
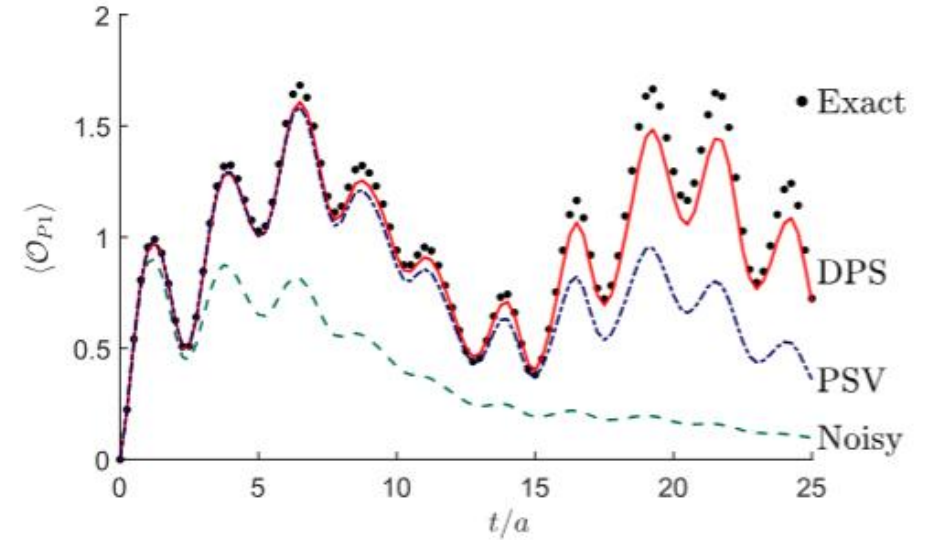

# Conclusions & outlook

## Take home messages

- Quantum Zeno effect and gauge protection: Digital vs analog quantum simulations.

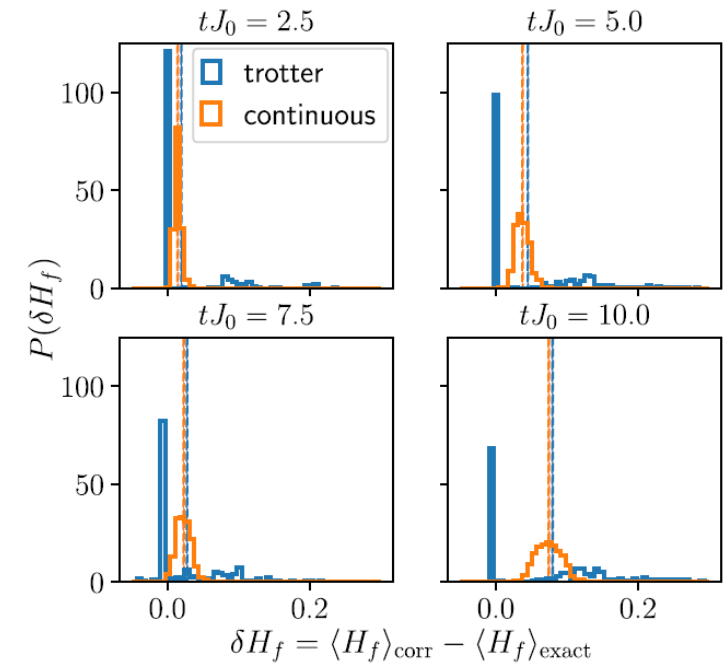

# Conclusions & outlook

## Take home messages

- Quantum Zeno effect and gauge protection: Digital vs analog quantum simulations.
- Dynamical post selection: promising tool for qudit/nonabelian LGT.
- Extension of symmetry verification to qudit and nonabelian groups

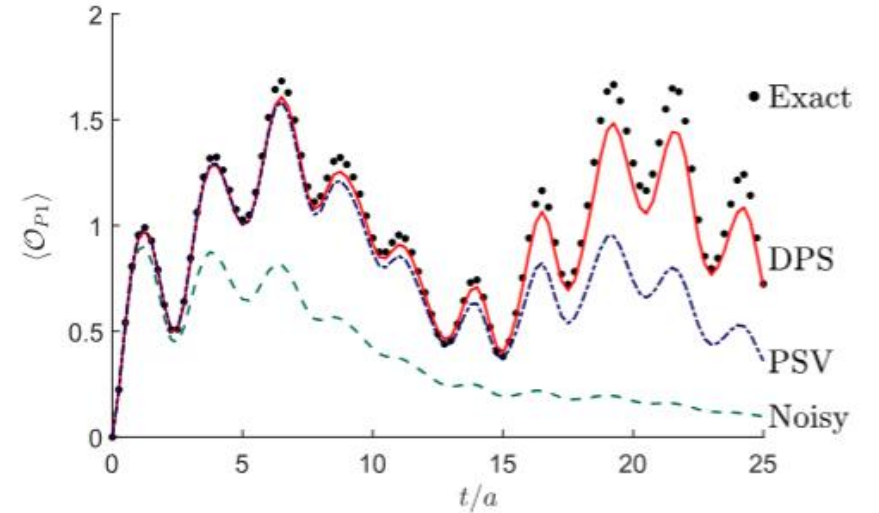

# Conclusions & outlook

## Take home messages

- Quantum Zeno effect and gauge protection: Digital vs analog quantum simulations.
- Dynamical post selection: promising tool for qudit/nonabelian LGT.
- Extension of symmetry verification to qudit and nonabelian groups
- $\mathbb{Z}_2$  LGT  $\Rightarrow$  DPS+error correction

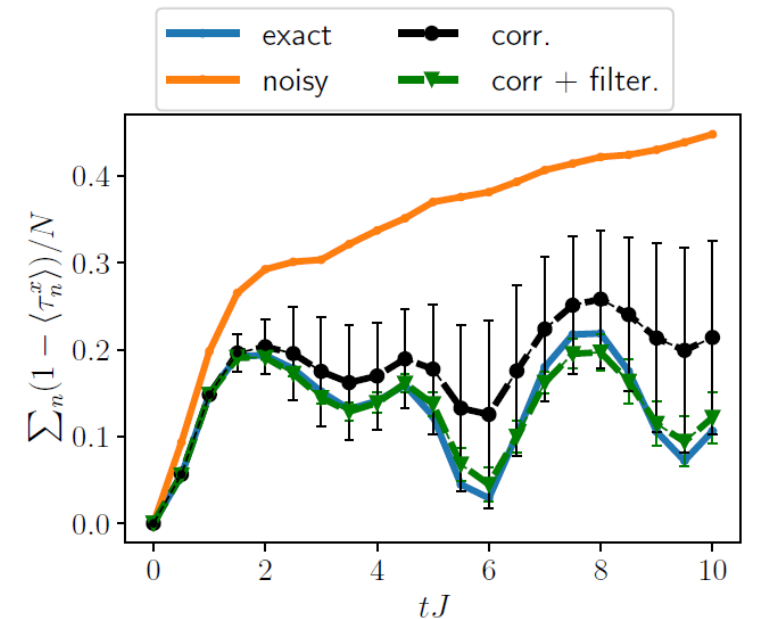
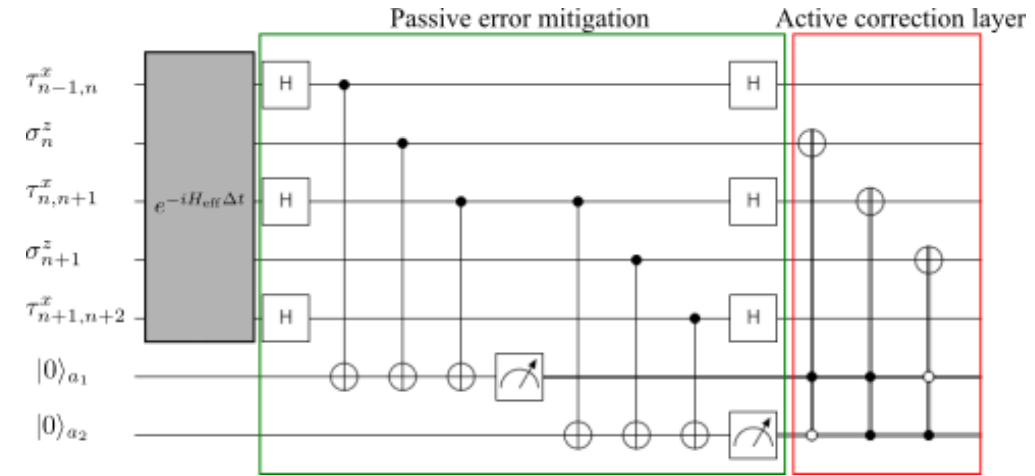

# Conclusions & outlook

## Take home messages

- Quantum Zeno effect and gauge protection: Digital vs analog quantum simulations.
- Dynamical post selection: promising tool for qudit/nonabelian LGT.
- Extension of symmetry verification to qudit and nonabelian groups
- $\mathbb{Z}_2$  LGT  $\Rightarrow$  DPS+error correction

## What's next?

- Measurement-induced chaos / chaos-integrability transition in the trajectory statistics
- Adapt to specific LGT model and hardware
- Generalize of PSV in qudits + workable approximations

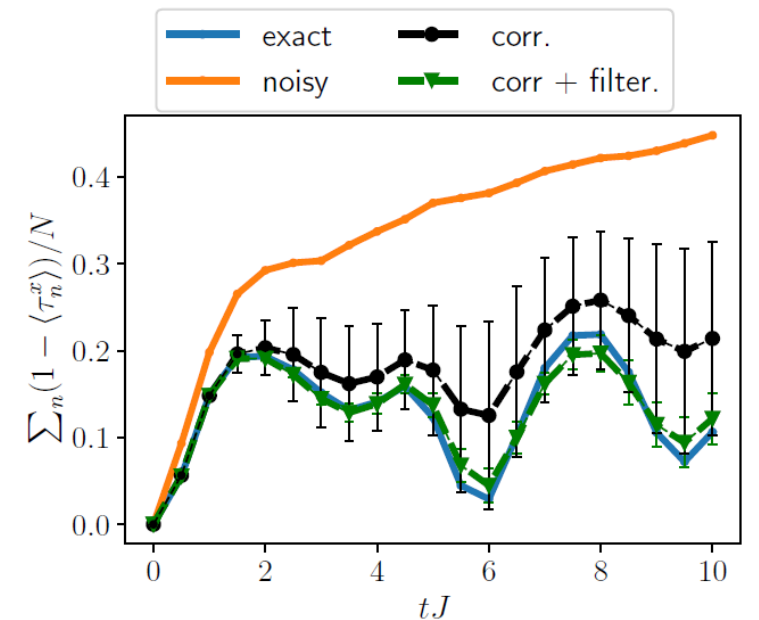
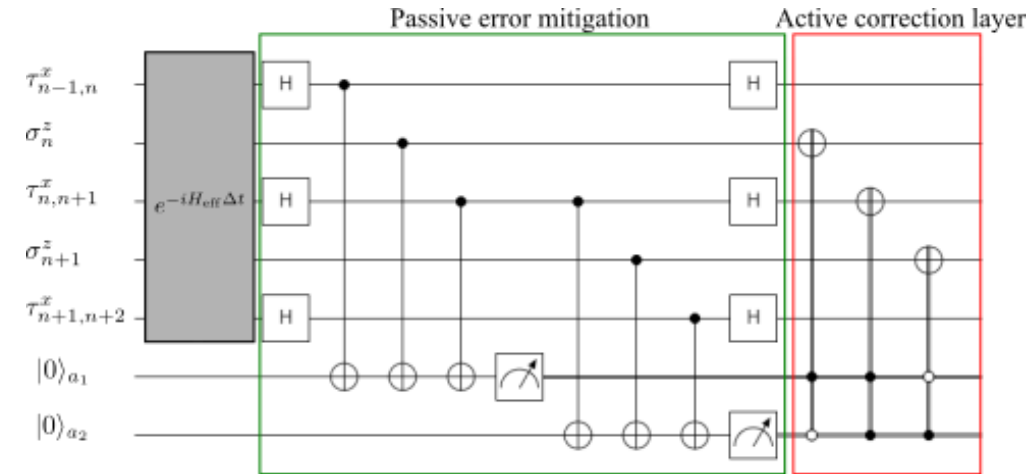

# Acknowledgements

Philipp Hauke



Edoardo Ballini

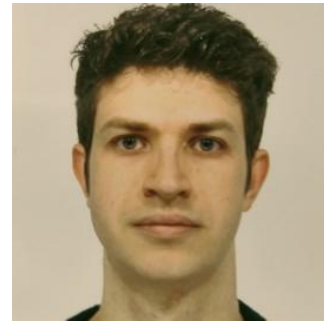

Alberto Biella



Julius Mildenberger



**MW**, E. Ballini, A Biella, P Hauke Phys. Rev. B 111 (2025)

E Ballini, J Mildenberger, **MW**, P Hauke arxiv: 2412.07844



UNIVERSITÀ  
DI TRENTO



BEC



Istituto Nazionale  
di Fisica Nucleare  
**TIFPA**  
Trento  
Institute for  
Fundamental  
Physics and  
Applications



Funded by the European Union. Views and opinions expressed are however those of the author(s) only and do not necessarily reflect those of the European Union or the European Commission. Neither the European Union nor the granting authority can be held responsible for them.

# Noisy measurements

Imperfect coupling between computational qubits and ancilla

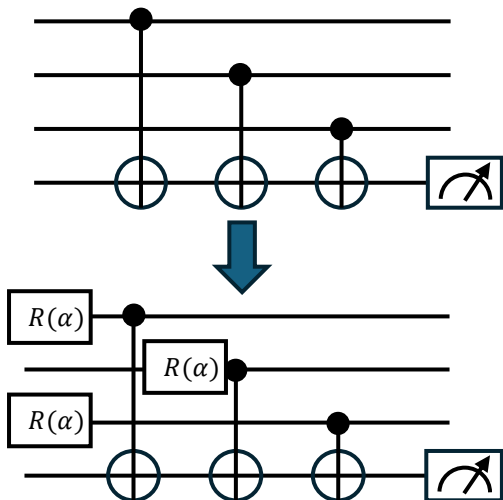

$$R(\alpha) = e^{-i\alpha_z Z} e^{-i\alpha_x X}, \quad \alpha_{x/z} \in \left[-\frac{\eta}{2}, \frac{\eta}{2}\right]$$

$$\text{Measurement fidelity } \mathcal{F}(\eta) \approx 1 - 3\eta^2$$

- ? Does the Zeno gauge-protection survive?
- ? Is there any advantage in DPS?

$$\mathcal{L}[\rho] \rightarrow \mathcal{L}_{\mathcal{F}=1}[\rho] + \gamma\eta^2 \sum_l \sum_{C=X,Z} C_l \rho C_l^\dagger - \frac{1}{2} \{C_l^\dagger C_l, \rho\}$$

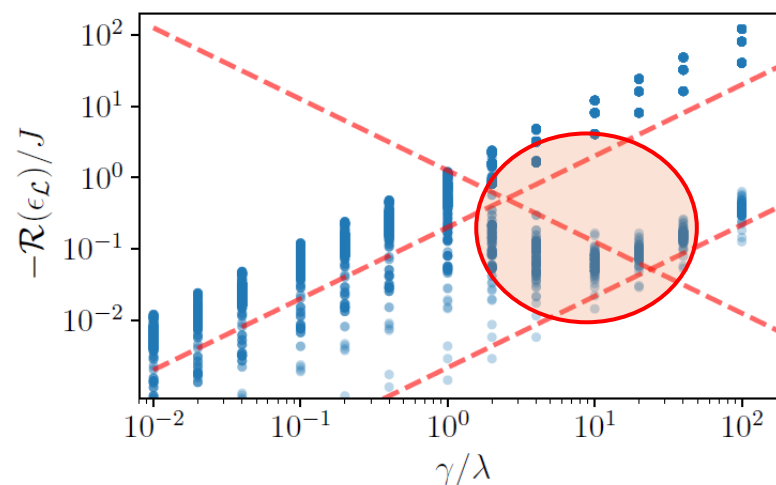

# Noisy measurements

Imperfect coupling between computational qubits and ancilla

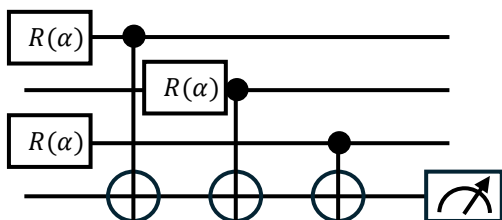

Liouvillian spectrum

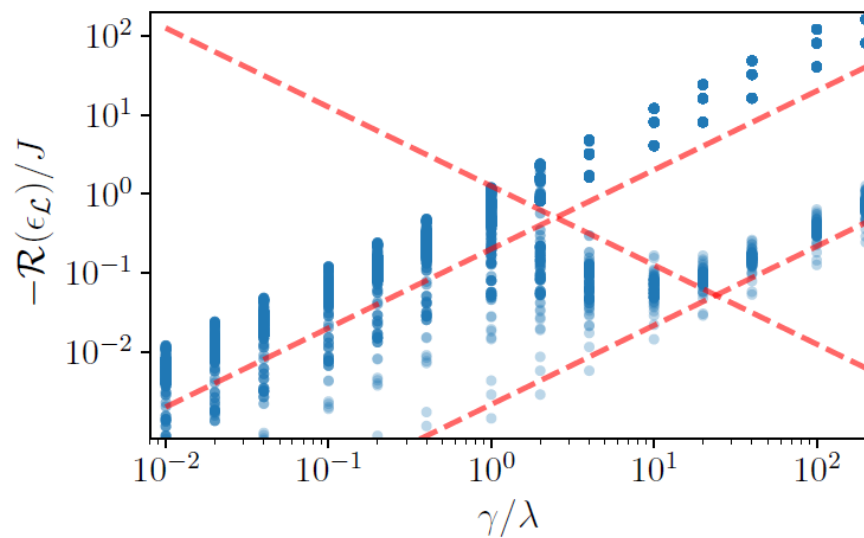

- ? Does the Zeno gauge-protection survive?
- ? Is there any advantage in DPS?

Trotterized dynamics with measurement frequency  $1/\tau$ ,  $\tau = m\Delta t$

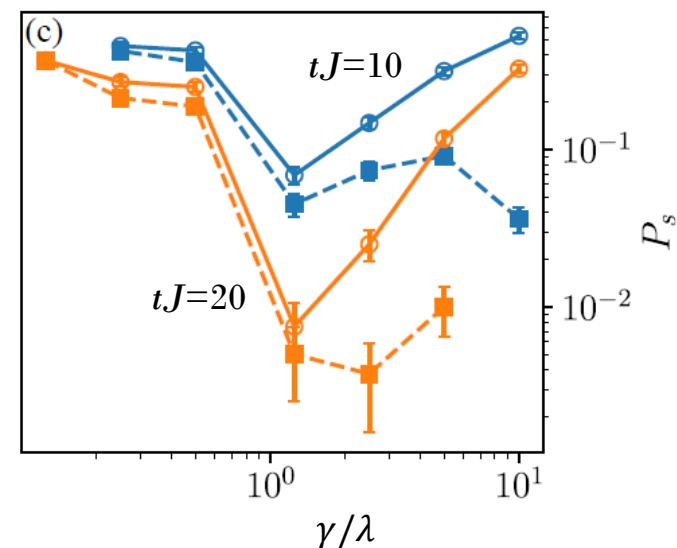
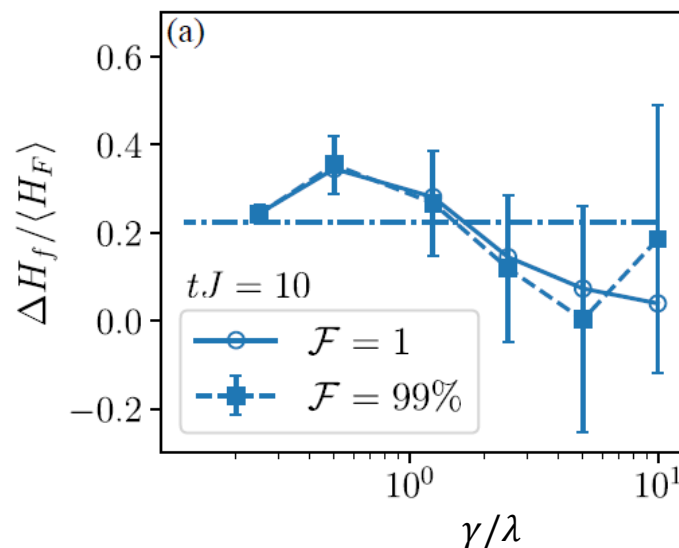

# Towards error correction

Add bit-flip ( $X$ ) error channel

$$\rho(t + \Delta t) = (1 - Lp_{\text{err}})U(\Delta t)\rho(t)U^\dagger(\Delta t) + p_{\text{err}} \sum_n U(\Delta t)X_n\rho(t)X_nU^\dagger(\Delta t)$$

$p_{\text{err}}$  = bit-flip error probability per Trotter step

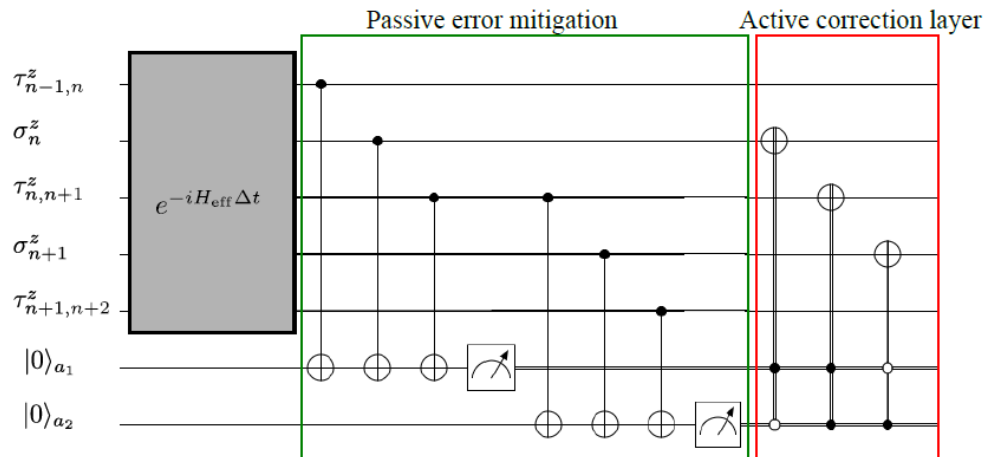
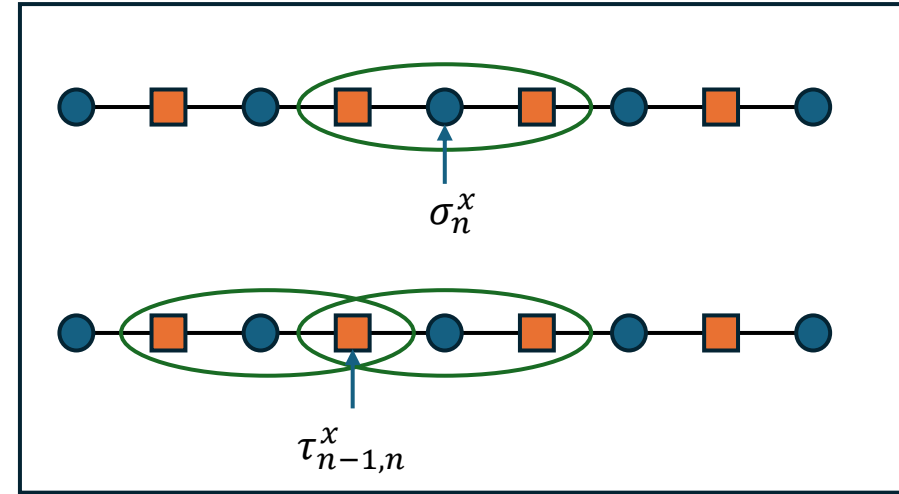

# Towards error correction

Add bit-flip ( $X$ ) error channel

$$\rho(t + \Delta t) = (1 - Lp_{\text{err}})U(\Delta t)\rho(t)U^\dagger(\Delta t) + p_{\text{err}} \sum_n U(\Delta t)X_n\rho(t)X_nU^\dagger(\Delta t)$$

$p_{\text{err}}$  = bit-flip error probability per Trotter step

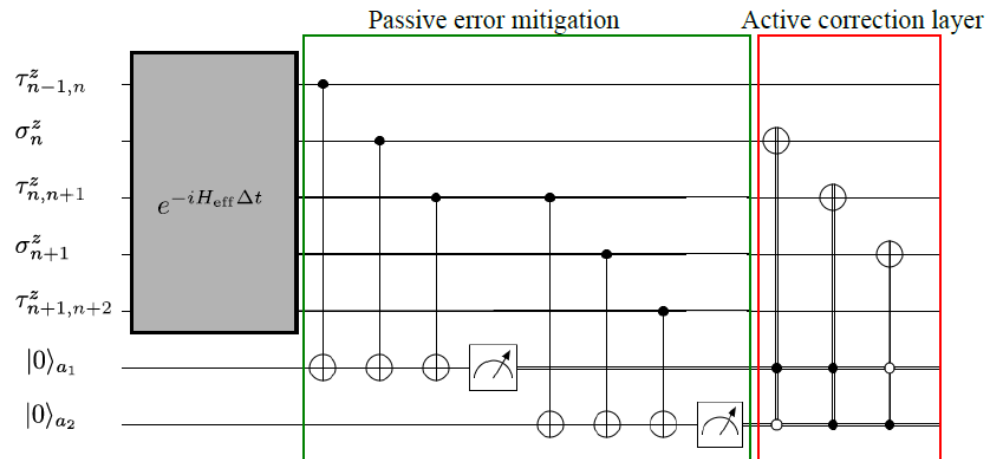
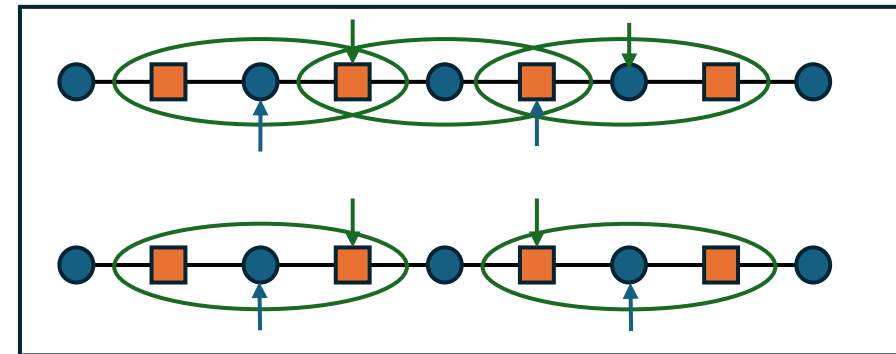
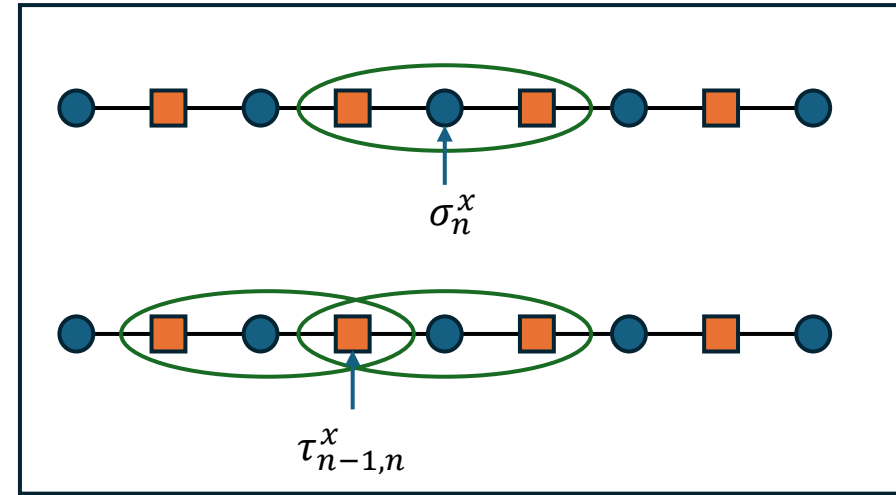

# Towards error correction

Add bit-flip ( $X$ ) error channel

$$\rho(t + \Delta t) = (1 - Lp_{\text{err}})U(\Delta t)\rho(t)U^\dagger(\Delta t) + p_{\text{err}} \sum_n U(\Delta t)X_n\rho(t)X_nU^\dagger(\Delta t)$$

$p_{\text{err}}$  = bit-flip error probability per Trotter step

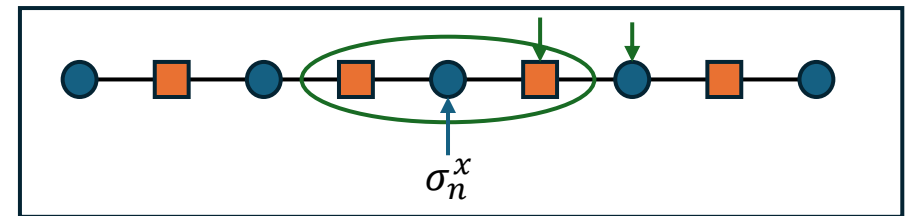
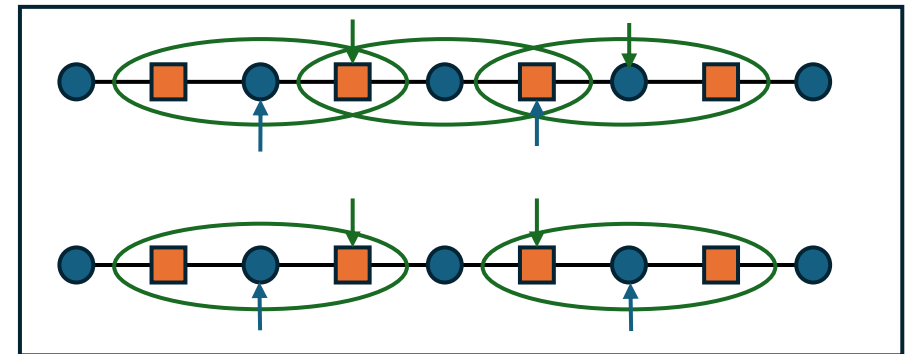
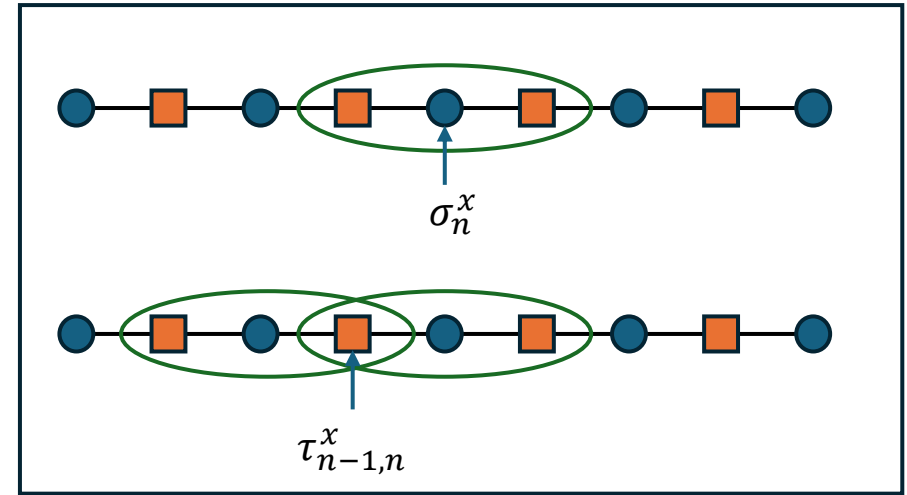
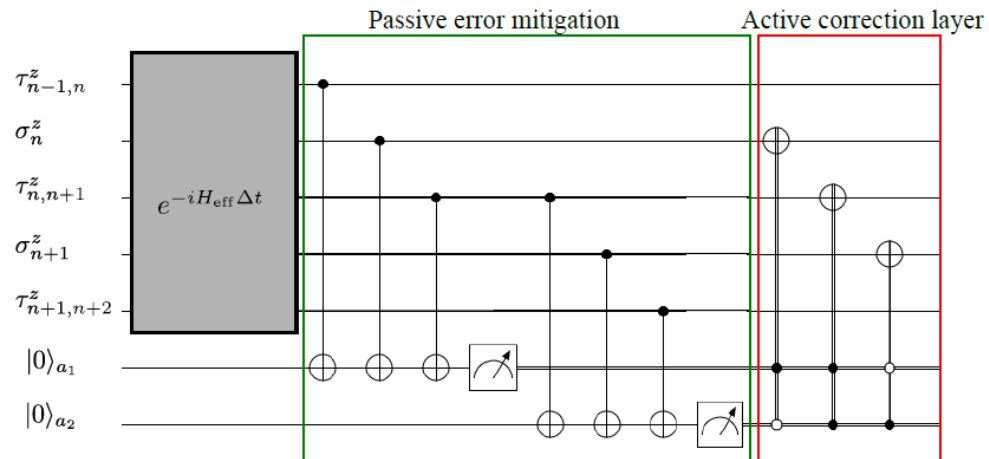

# Towards error correction

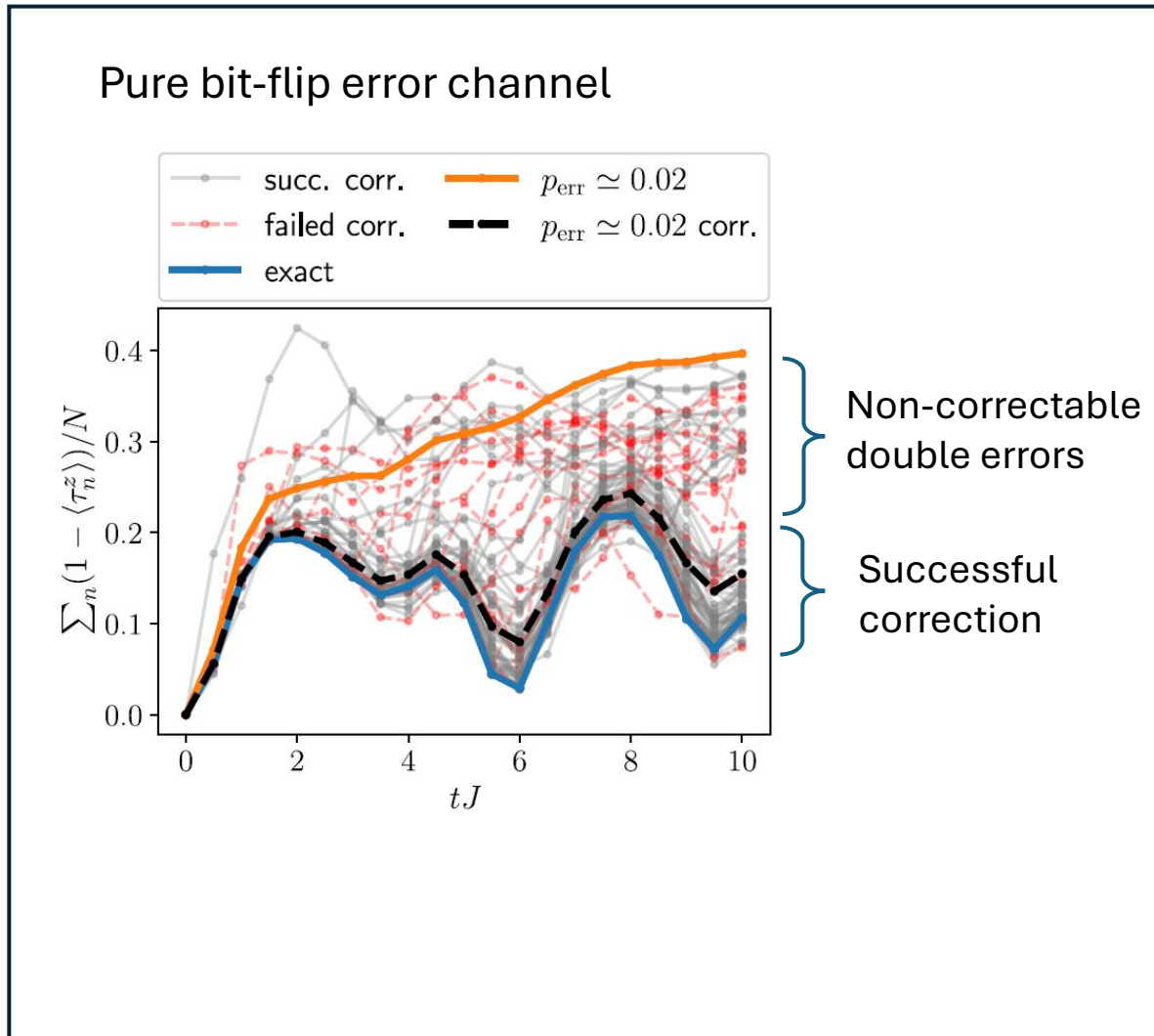

# Towards error correction

Pure bit-flip error channel

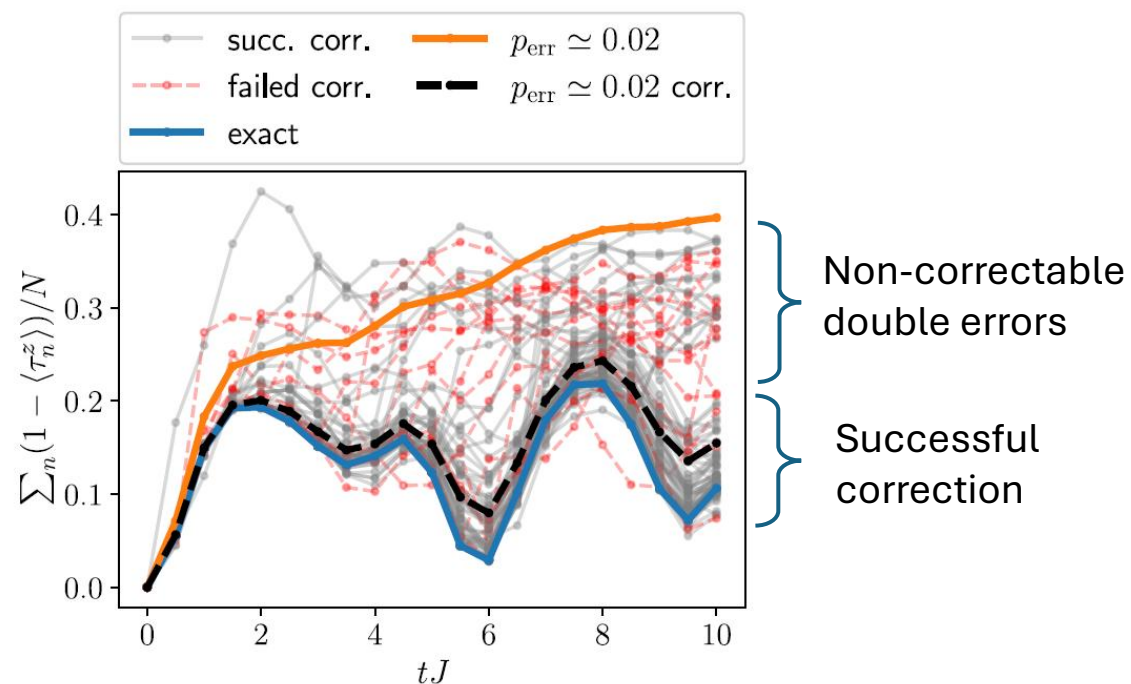

Bit flip + coherent error

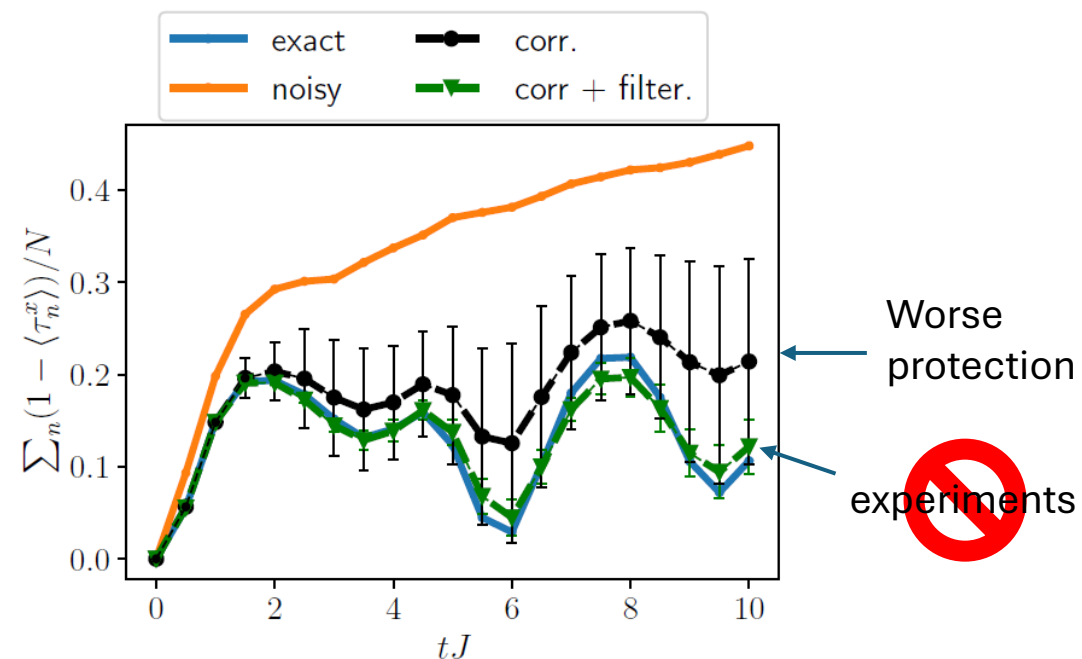

Quantum Zeno effect suppresses coherent gauge drift.  
 Conditional operations correct incoherent bit flips.

# Measurement-induced gauge protection in digital quantum simulations

$$\dot{\rho} = -i\hbar[\hat{H}, \rho] + \gamma \sum_n \hat{G}_n \rho \hat{G}_n^\dagger - \frac{1}{2} \{ \hat{G}_n^\dagger \hat{G}_n, \rho \} = \mathcal{L}\rho$$

Possible implementations:

- Engineered dissipation [1]
- Random gage transformations [2]
- Continuous measurements
- Continuous limit for DPS

**Quantum Zeno transition between protected (QZP) and chaotic phases**

**Importance of unraveling: same ensemble average, different stochastic trajectories**

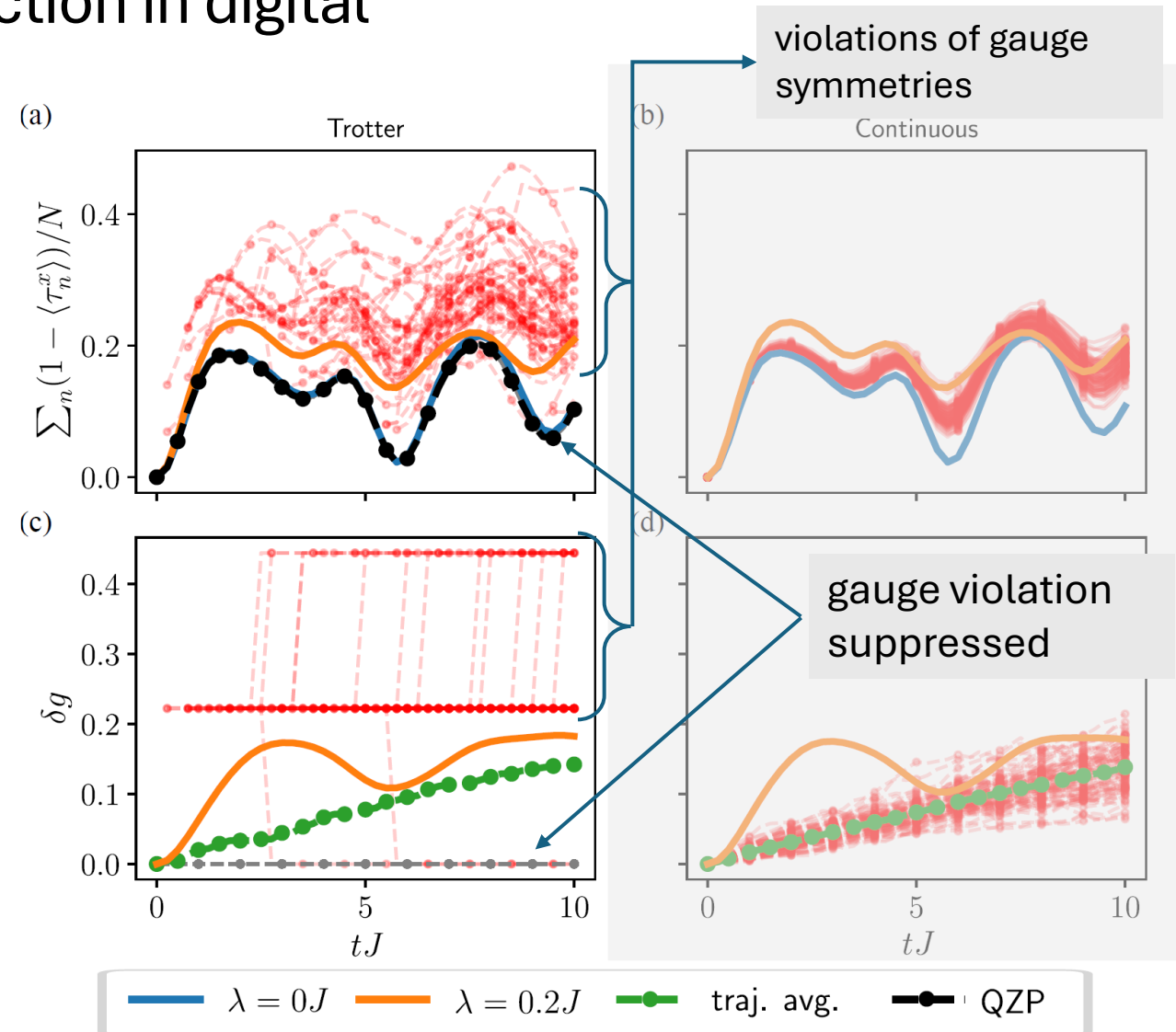

[1] Stannigel et al. PRL **112** (2014)

[2] Lamm et al. arxiv:2005.12688

# Measurement-induced gauge protection in digital quantum simulations

$$\dot{\rho} = -i\hbar[\hat{H}, \rho] + \gamma \sum_n \hat{G}_n \rho \hat{G}_n^\dagger - \frac{1}{2} \{ \hat{G}_n^\dagger \hat{G}_n, \rho \} = \mathcal{L}\rho$$

Possible implementations:

- Engineered dissipation [1]
- Random gage transformations [2]
- Continuous measurements
- Continuous limit for DPS

**Quantum Zeno transition between protected (QZP) and chaotic phases**

**Importance of unraveling: same ensemble average, different stochastic trajectories**

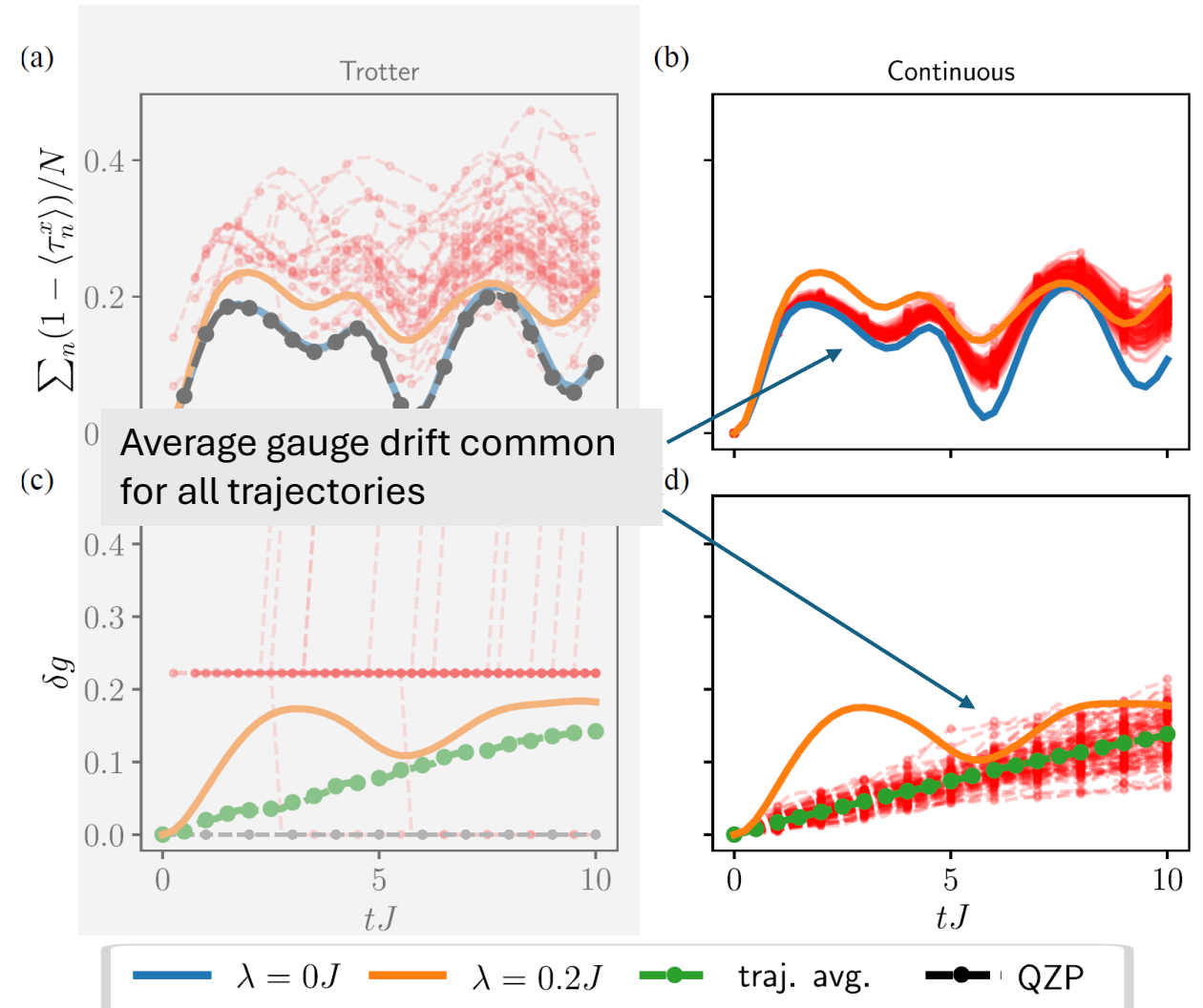

[1] Stannigel et al. PRL **112** (2014)

[2] Lamm et al. arxiv:2005.12688

# Measurement-induced gauge protection in digital quantum simulations

$$\dot{\rho} = -i\hbar[\hat{H}, \rho] + \gamma \sum_n \hat{G}_n \rho \hat{G}_n^\dagger - \frac{1}{2} \{ \hat{G}_n^\dagger \hat{G}_n, \rho \} = \mathcal{L}\rho$$

Possible implementations:

- Engineered dissipation [1]
- Random gage transformations [2]
- Continuous measurements
- Continuous limit for DPS

**Quantum Zeno transition between protected (QZP) and chaotic phases**

**Importance of unraveling: same ensemble average, different stochastic trajectories**

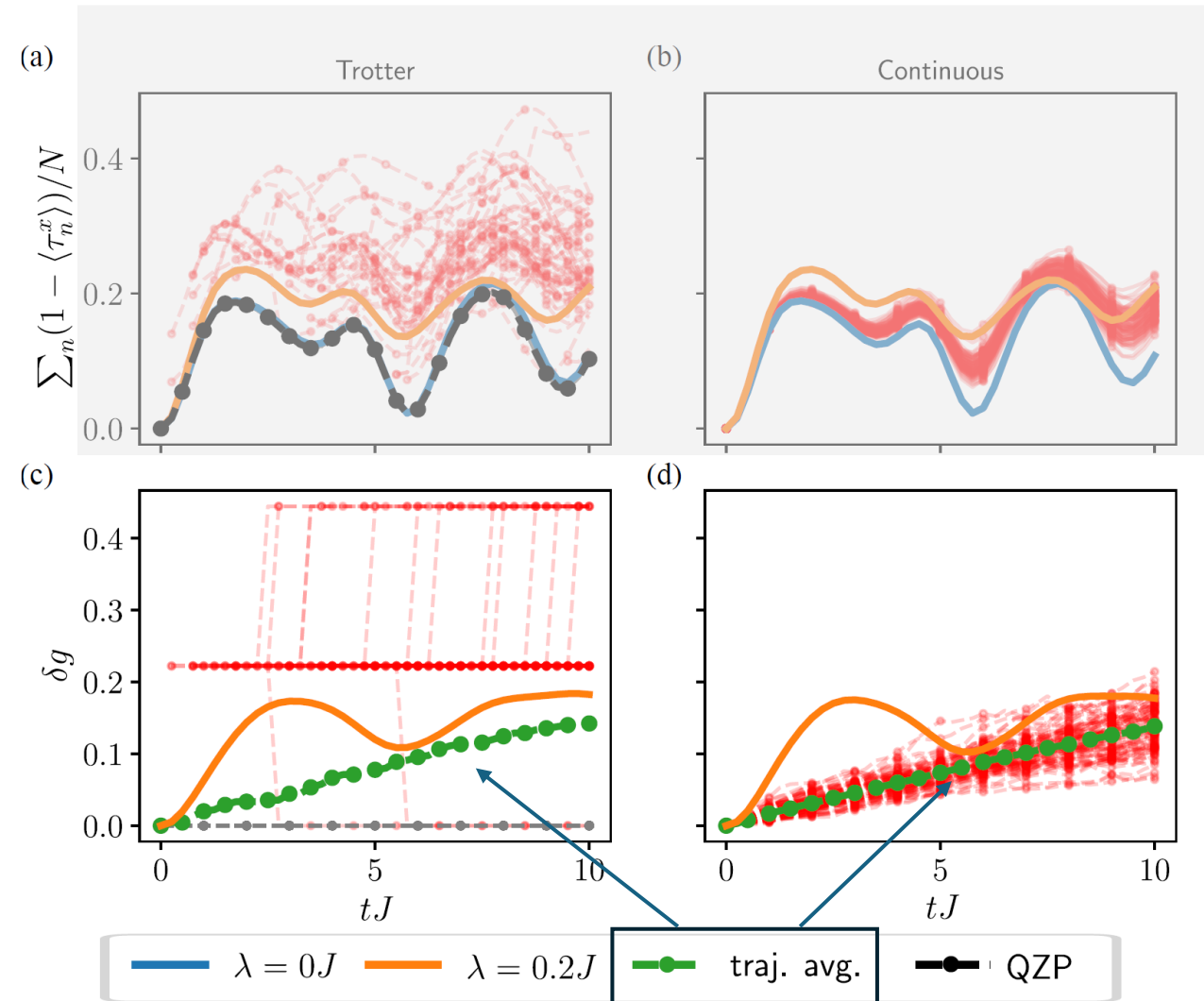

[1] Stannigel et al. PRL **112** (2014)

[2] Lamm et al. arxiv:2005.12688