



Funded by
the European Union
NextGenerationEU



Luca Tagliacozzo

S. Carignano (BSC), C. Ramos (UB) arXiv:2307.11649 PRL 2024
M. Piani (evolutionQ) J. Surace (ICFO) arXiv:1810.01231 PRB 2019
M. Frias-Perez (MPQ) MC. Bañuls (MPQ) arXiv:2308.04291
G. Lami (CYU), J. De Nardis (CYU)

Overcoming the entanglement barrier,
I) MC sampling of amplitudes
II) Trading entanglement for mixture



Plan de Recuperación,
Transformación y Resiliencia

PGC2018-095862-B-C22
PID2021-127968NB-I00
TED2021-130552B-C22



- 
- Out of equilibrium
 - Spatio-temporal tensor networks
 - Entanglement barrier
 - MC sampling and transverse contraction
 - Sampling amplitudes
 - The boundary states
 - Scaling of generalized temporal entropies with time(CFT)
 - Trading entanglement for mixture
 - Unveiling local equilibration
 - Identifying fast degrees of freedom
 - Relation with decoherence
 - Conclusions

- 
- Out of equilibrium
 - Spatio-temporal tensor networks
 - Entanglement barrier
 - MC sampling and transverse contraction
 - Sampling amplitudes
 - The boundary states
 - Scaling of generalized temporal entropies with time(CFT)
 - Trading entanglement for mixture
 - Unveiling local equilibration
 - Identifying fast degrees of freedom
 - Relation with decoherence
 - Conclusions

Classical:

Kapitsa pendulum

Quantum:

Light induced superconductor

Bukov

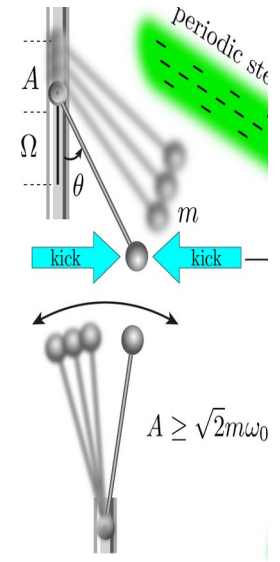

Cavalleri

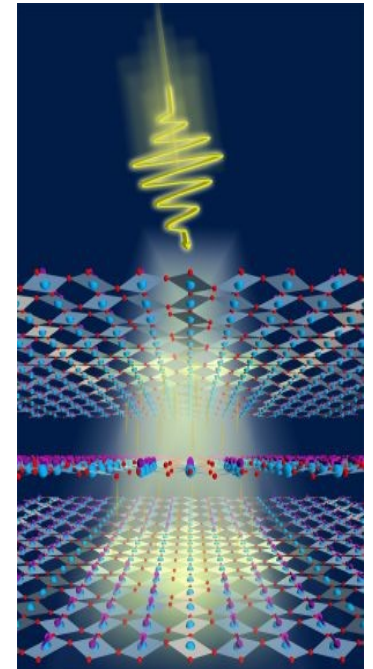
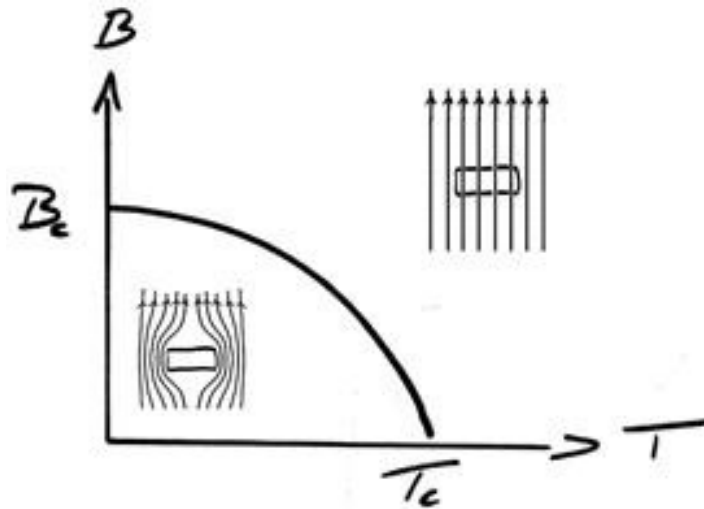



Tensor Networks

$$A = \begin{bmatrix} A_1 \\ A_2 \\ \vdots \\ A_m \end{bmatrix} \quad B = \begin{bmatrix} B_{11} & \cdots & B_{1n} \\ \vdots & \ddots & \vdots \\ B_{m1} & \cdots & B_{mn} \end{bmatrix} \quad C = \begin{bmatrix} \begin{bmatrix} C_{111} & \cdots & C_{1n1} \end{bmatrix}^1 \\ \vdots \\ \begin{bmatrix} C_{m11} & \cdots & C_{mn1} \end{bmatrix}^2 \end{bmatrix}^3$$

$$\text{---} \bigcirc_C \text{---} = \text{---} \bigcirc_A \text{---} \bigcirc_B \text{---}$$

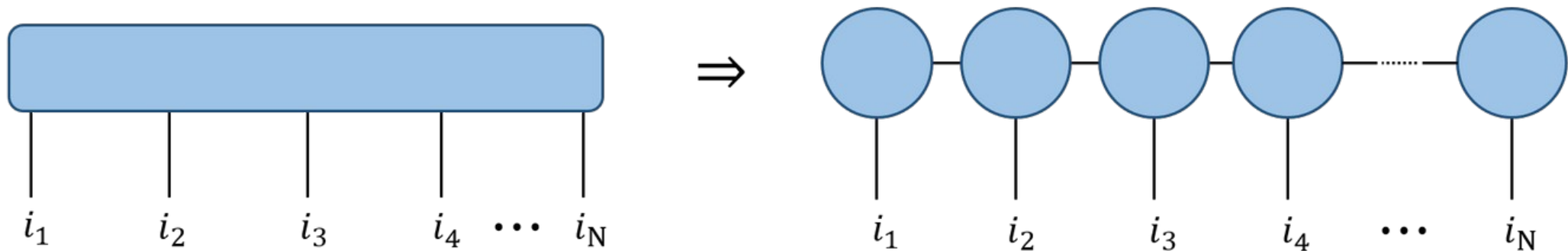
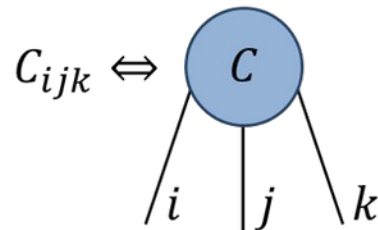
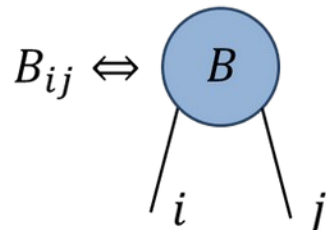
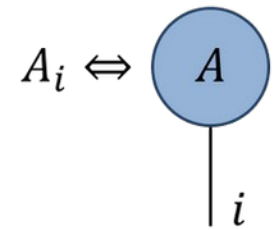
$$\Leftrightarrow C_{ik} = \sum_j A_{ij} B_{jk}$$



- 
- Out of equilibrium
 - Spatio-temporal tensor networks
 - Entanglement barrier
 - MC sampling and transverse contraction
 - Sampling amplitudes
 - The boundary states
 - Scaling of generalized temporal entropies with time(CFT)
 - Trading entanglement for mixture
 - Unveiling local equilibration
 - Identifying fast degrees of freedom
 - Relation with decoherence
 - Conclusions



Esperanza Lopez (CSIC-IFT),
Sergio Cerezo (CSIC-IFT),
Aleix Bou (CSIC-IFF).
Jan Schneider (CSIC-IFF),
Stefano Carignano (BSC).



Review on Spatio-Temporal Tensor Networks

arXiv:2502.20214

Luca Tagliacozzo, OED for HEP CERN 25

$$H = \sum_i h_i$$

$$U(T) = \exp(-iHT)$$

$$O(T) = U^\dagger(T) O_i U(T)$$

$$\langle \psi_0 | O(T) | \psi_0 \rangle$$

$$U(T) = \exp(-iHT)$$

$$\delta t = t/N \ll 1$$

$$U(T) \simeq U(\delta t)^N$$

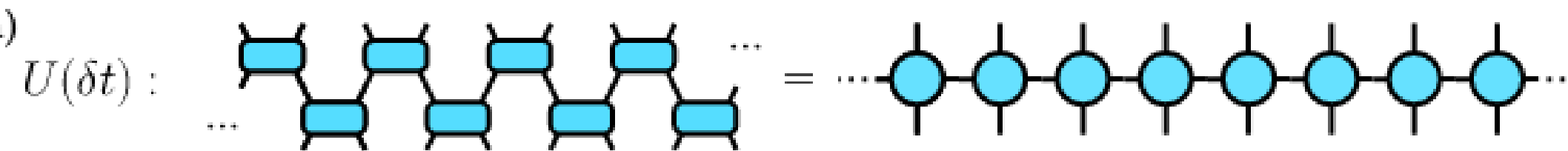

.. ≡





(c)

$\langle O_i(T) \rangle :$

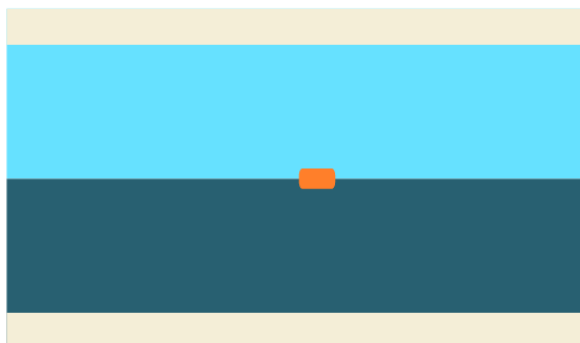
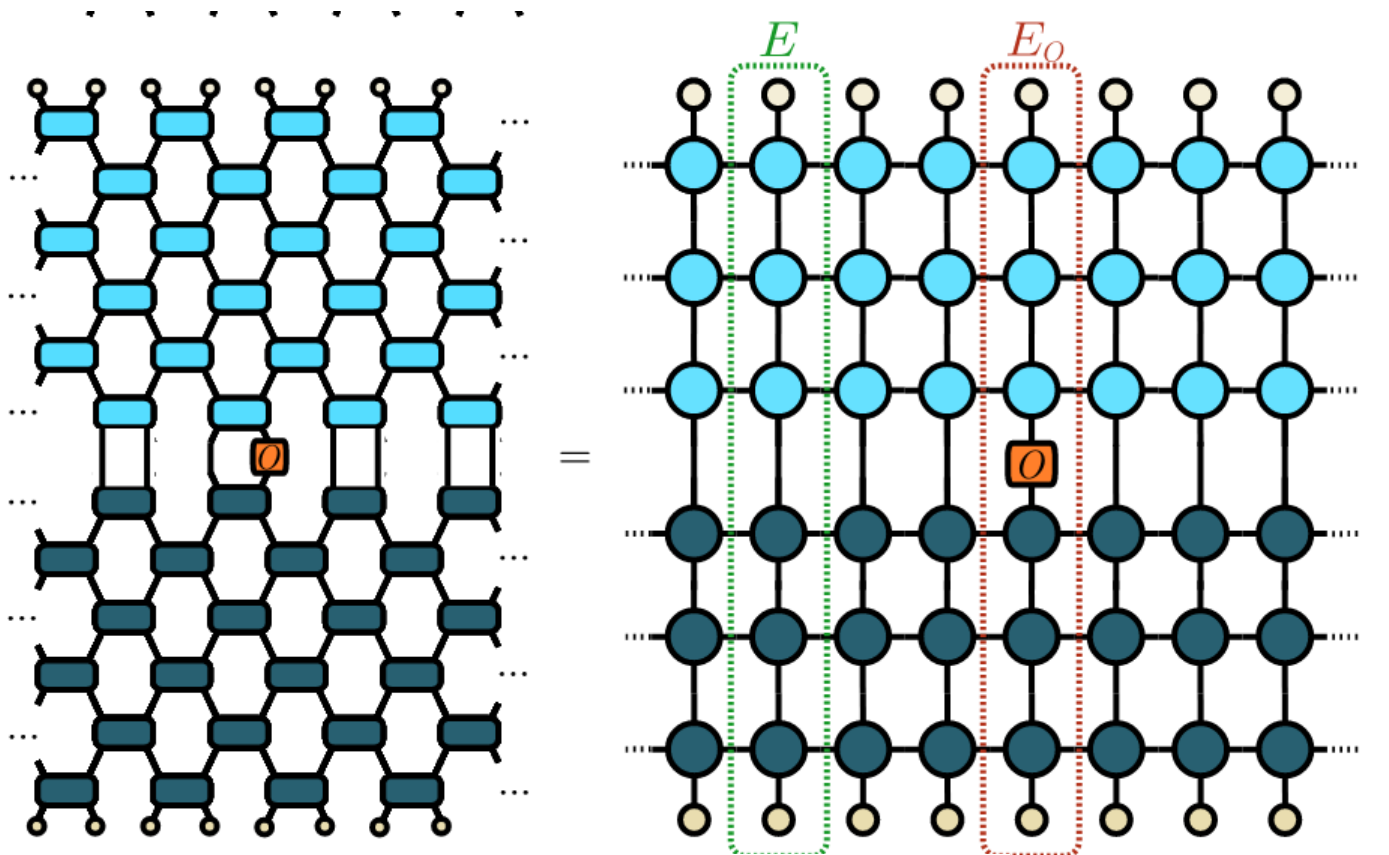

- 
- Out of equilibrium
 - Spatio-temporal tensor networks
 - **Entanglement barrier**
 - MC sampling and transverse contraction
 - Sampling amplitudes
 - The boundary states
 - Scaling of generalized temporal entropies with time(CFT)
 - Trading entanglement for mixture
 - Unveiling local equilibration
 - Identifying fast degrees of freedom
 - Relation with decoherence
 - Conclusions

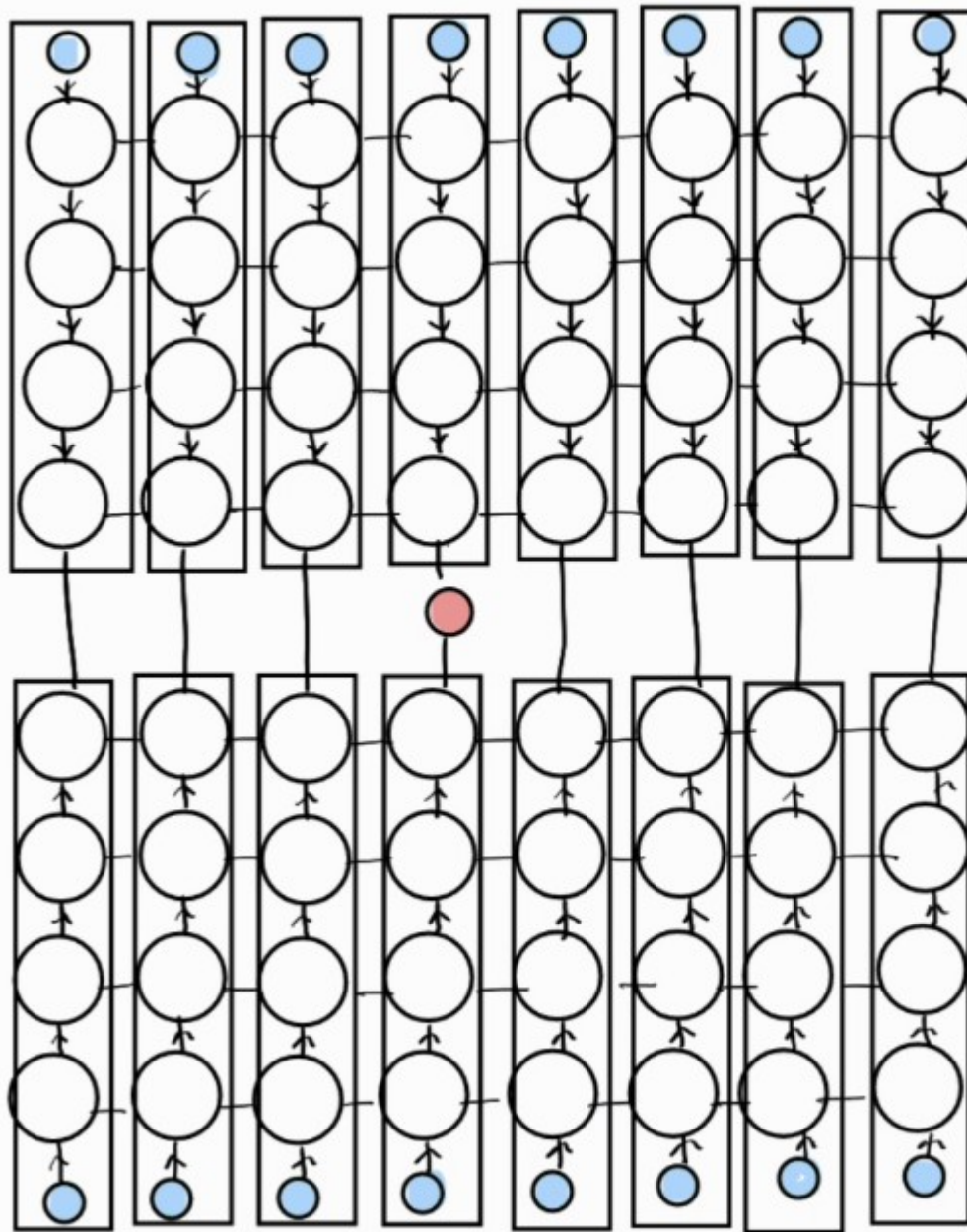

$|\psi(t)\rangle$

θ_i

$\langle\phi(t)|$

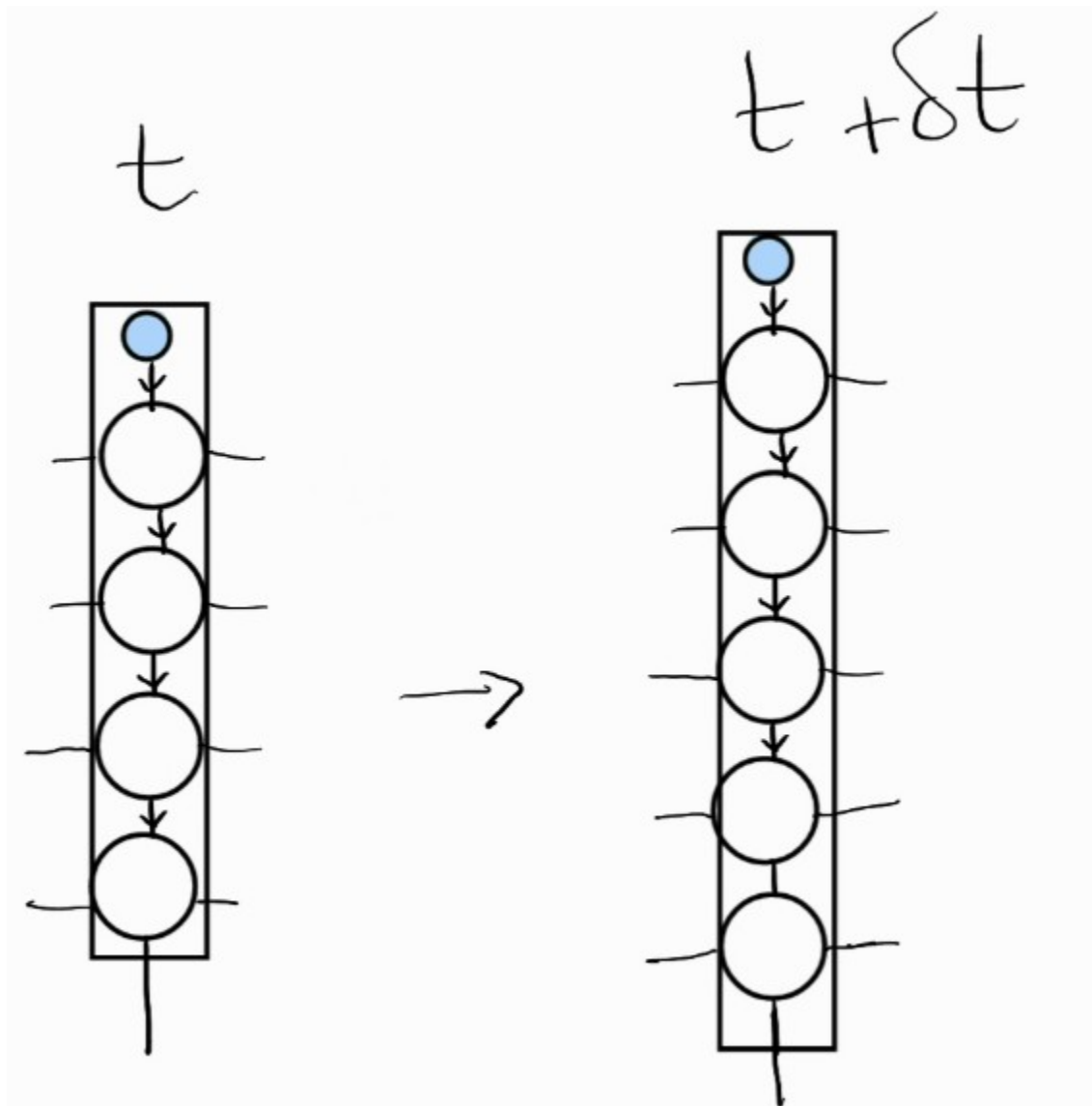

What is the actual computational cost?

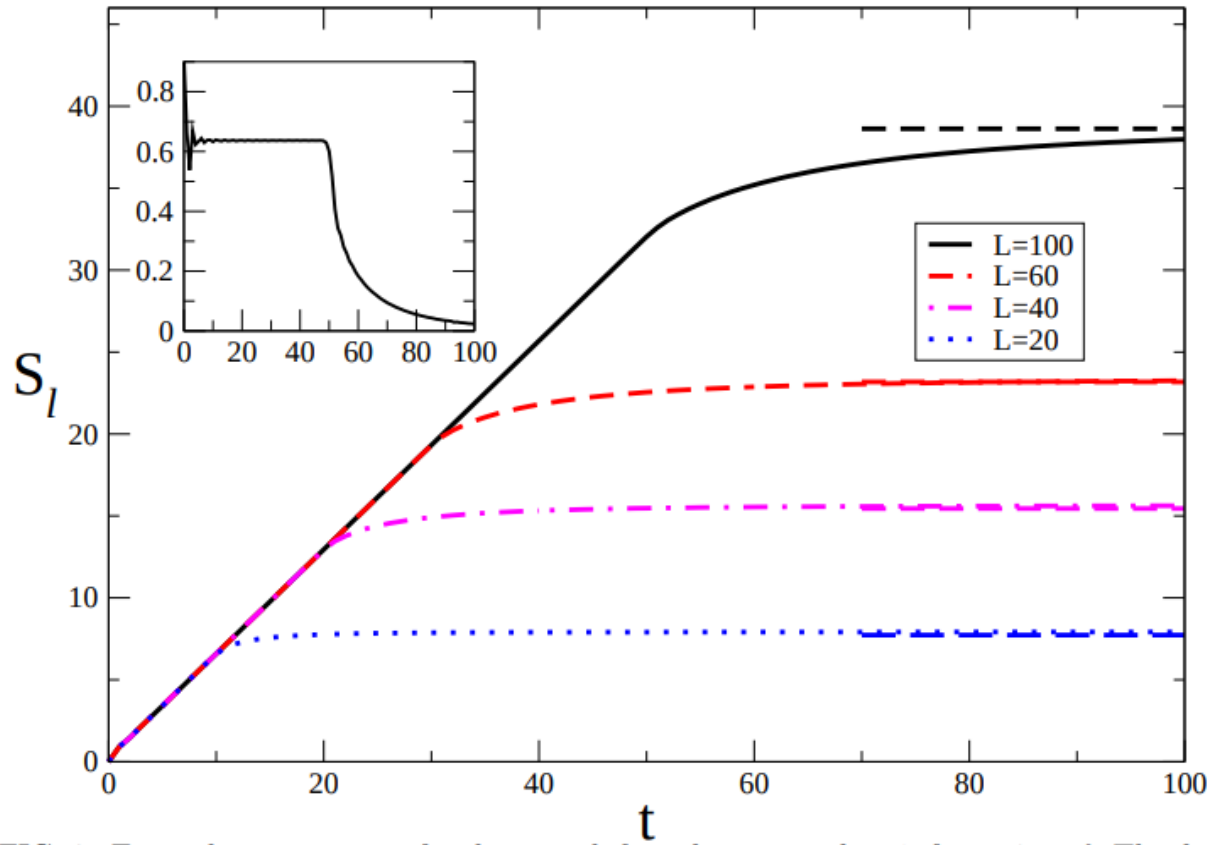
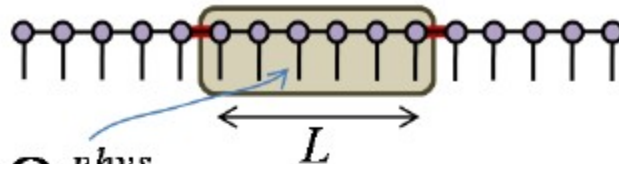

from Calabrese Cardy 2005

$$S \leq n_{AB} \log(\chi)$$

$$\chi^{n_{AB}} \geq \exp S \propto \exp(t)$$



Stefano Carignano (BSC), Guglielmo Lami (CYU-FR),
Jacopo De Nardis (CYU-FR)

Overcoming the entanglement barrier with sampled tensor networks

arXiv:2505.09714

- 
- Out of equilibrium
 - Spatio-temporal tensor networks
 - Entanglement barrier
 - **MC sampling and transverse contraction**
 - Sampling amplitudes
 - The boundary states
 - Scaling of generalized temporal entropies with time(CFT)
 - Trading entanglement for mixture
 - Unveiling local equilibration
 - Identifying fast degrees of freedom
 - Relation with decoherence
 - Conclusions



(c)

$\langle O_i(T) \rangle :$

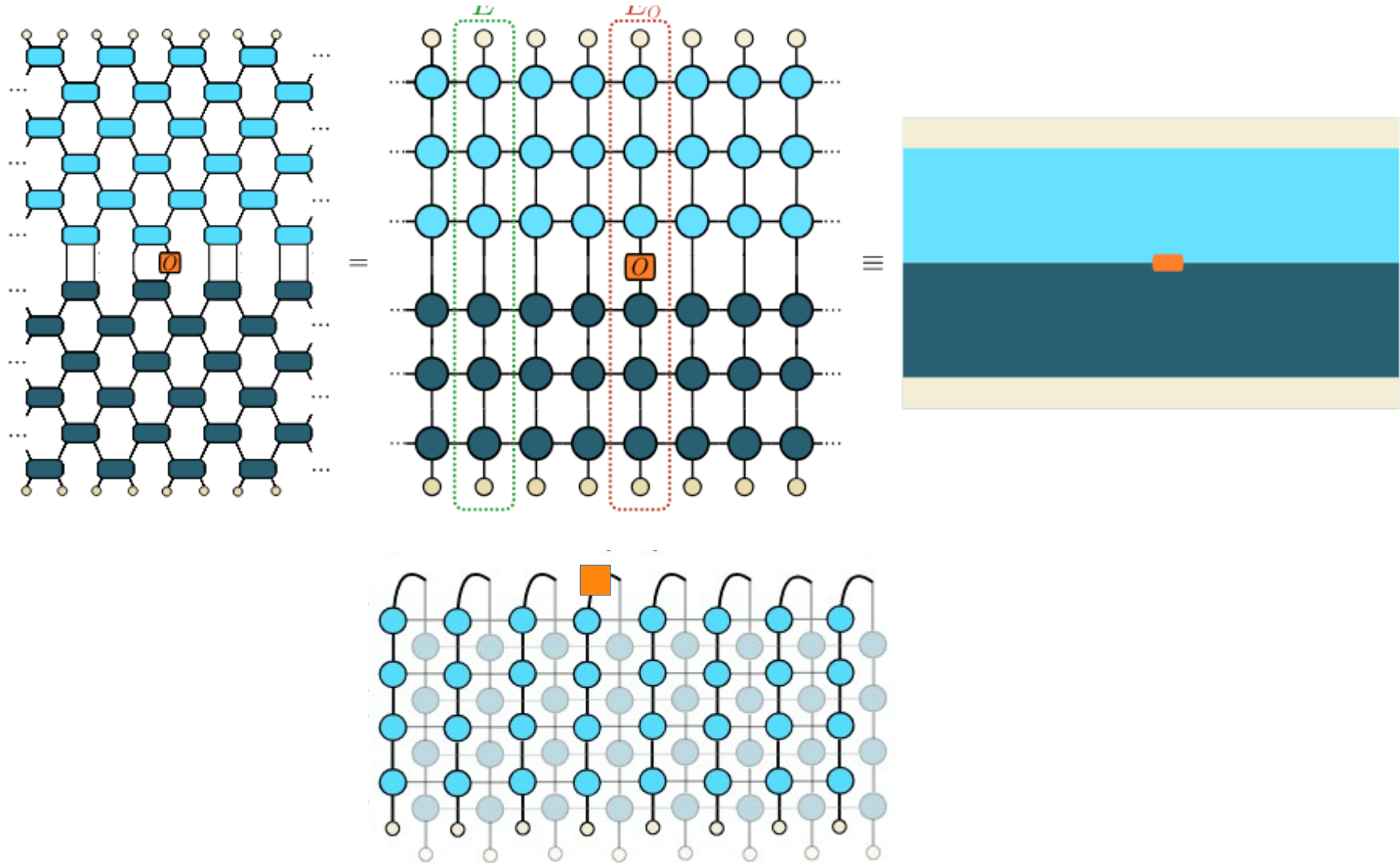

- 
- Measure all physical spins
 - Separate backwards from forward contour
 - Single sheet path integral, or
Single sheet tensor network

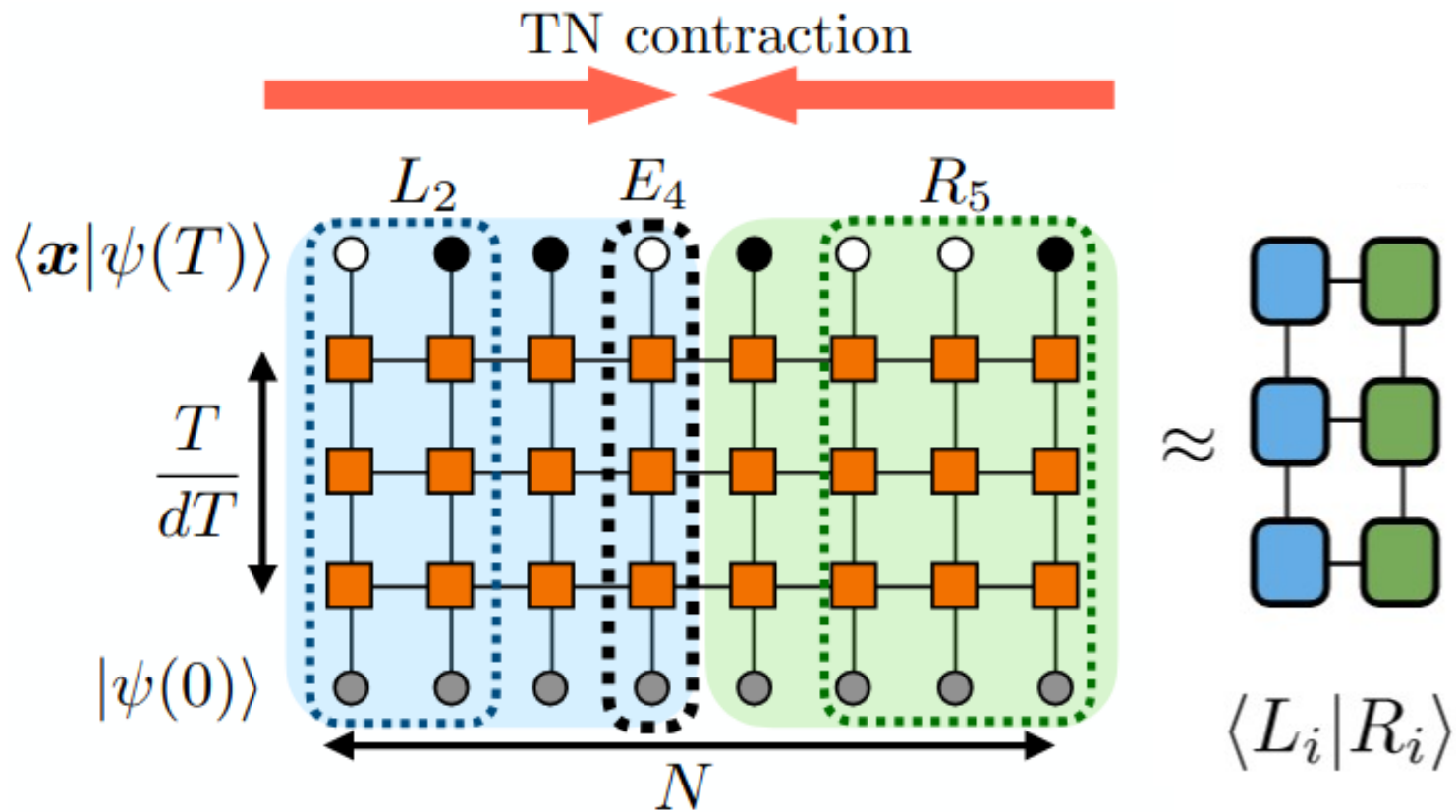

$$\langle O \rangle = \sum_{\mathbf{x}} p(\mathbf{x}) O_{\text{loc}}(\mathbf{x}), \quad p(\mathbf{x}; T) = |\langle \mathbf{x} | \psi(T) \rangle|^2,$$

- 
- Out of equilibrium
 - Spatio-temporal tensor networks
 - Entanglement barrier
 - MC sampling and transverse contraction
 - Sampling amplitudes
 - The boundary states
 - Scaling of generalized temporal entropies with time(CFT)
 - Trading entanglement for mixture
 - Unveiling local equilibration
 - Identifying fast degrees of freedom
 - Relation with decoherence
 - Conclusions

$$O_{\text{loc}}(\mathbf{x}) = \sum_{\mathbf{x}'} \frac{\langle \mathbf{x}' | \psi(T) \rangle}{\langle \mathbf{x} | \psi(T) \rangle} \langle \mathbf{x} | \hat{O} | \mathbf{x}' \rangle,$$

$$\langle O \rangle = \sum_{\mathbf{x}} p(\mathbf{x}) O_{\text{loc}}(\mathbf{x}), \quad p(\mathbf{x}; T) = |\langle \mathbf{x} | \psi(T) \rangle|^2,$$

Monte Carlo

$$\mathbf{x}^{(m)} \rightarrow \mathbf{x}^{(m+1)}$$

$$p_{\text{acc}} = \min\left(1, p(\mathbf{x}^{(m+1)}; T) / p(\mathbf{x}^{(m)}; T)\right).$$



Numerical results

$$\hat{H} = \sum_j (X_j X_{j+1} + h_z Z_j + h_x X_j),$$

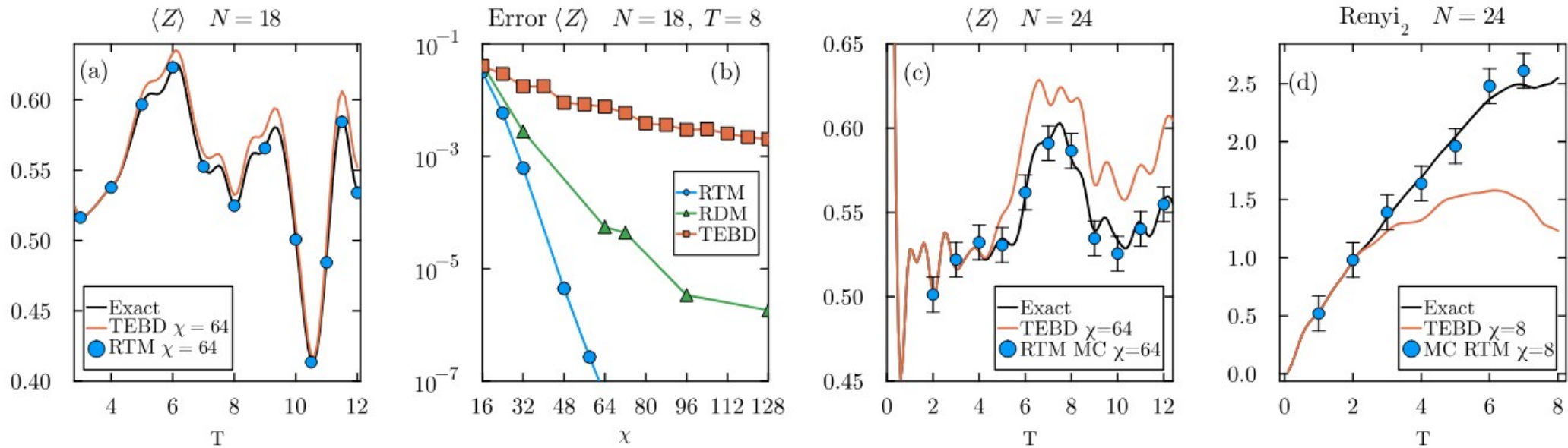

$$h_z = -1.05 \text{ and } h_x = 0.50.$$

- 
- Out of equilibrium
 - Spatio-temporal tensor networks
 - Entanglement barrier
 - MC sampling and transverse contraction
 - Sampling amplitudes
 - **The boundary states**
 - Scaling of generalized temporal entropies with time(CFT)
 - Trading entanglement for mixture
 - Unveiling local equilibration
 - Identifying fast degrees of freedom
 - Relation with decoherence
 - Conclusions

$$\langle \mathbf{x} | \psi(T) \rangle = \langle L_i | R_i \rangle,$$

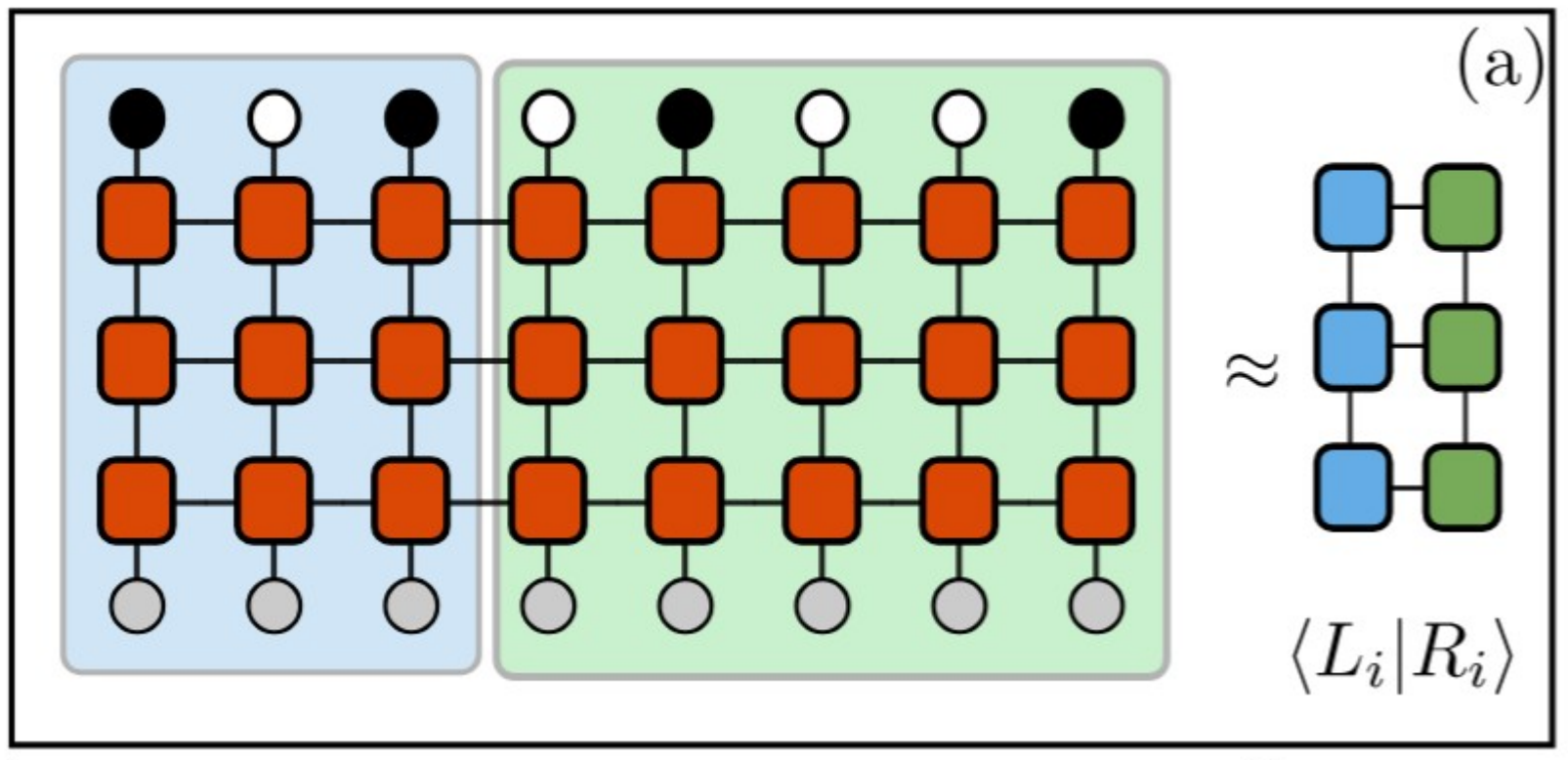

- 
- Out of equilibrium
 - Spatio-temporal tensor networks
 - Entanglement barrier
 - MC sampling and transverse contraction
 - Sampling amplitudes
 - The boundary states
 - **Scaling of generalized temporal entropies with time (CFT)**
 - Trading entanglement for mixture
 - Unveiling local equilibration
 - Identifying fast degrees of freedom
 - Relation with decoherence
 - Conclusions



Loschmidt echos and generalized temporal entropies from CFT

- with S. Carignano [arXiv:2405.14706](https://arxiv.org/abs/2405.14706)



$$\mathcal{L} = | \langle \psi_0 | e^{-iHT} | \psi_0 \rangle |, \quad l = -\frac{\log \mathcal{L}}{TL}.$$

H is a critical spin model Hamiltonian, e.g.
Ising, Potts

a) $|\psi_0\rangle$:

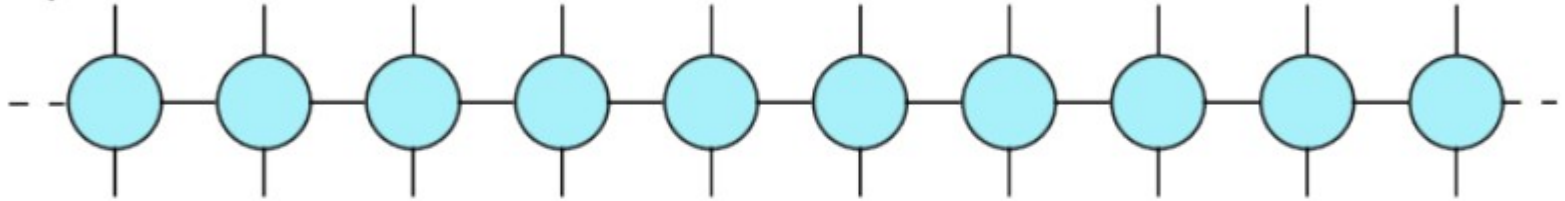

b) $U(\delta t)$:



c) $\langle \psi_0 | U(T) | \psi_0 \rangle_{\text{lat}}$:

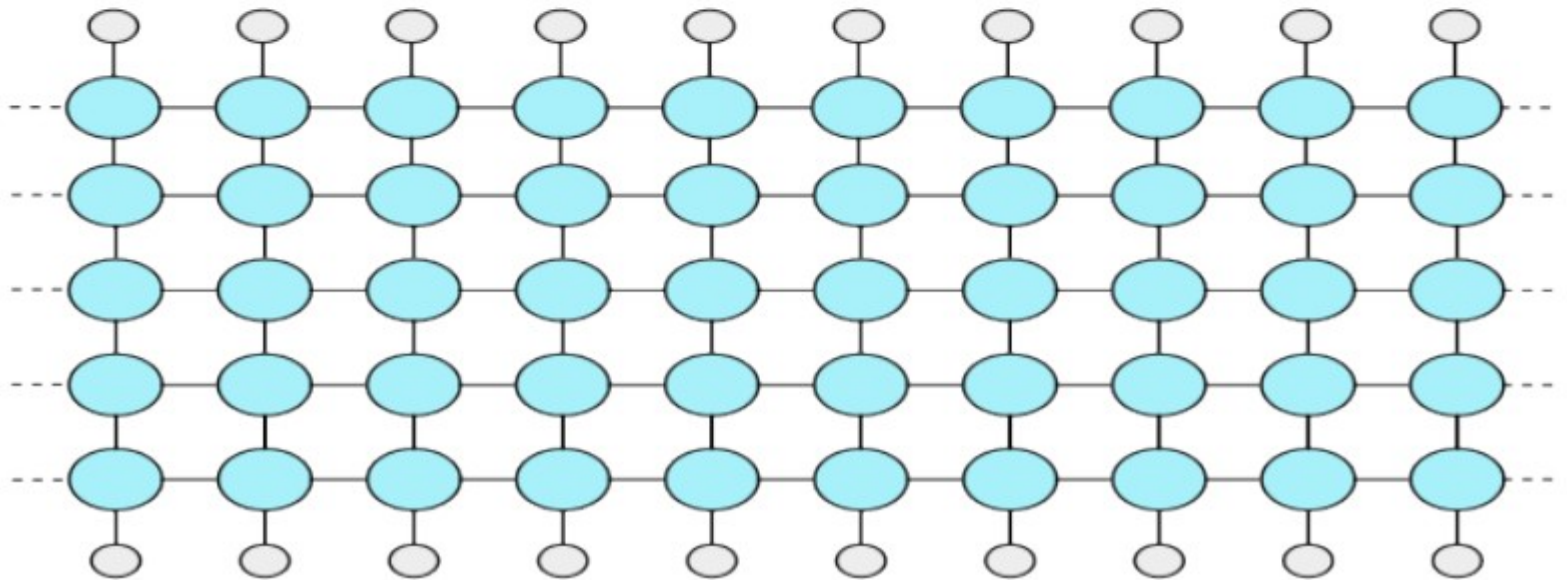

TN contraction

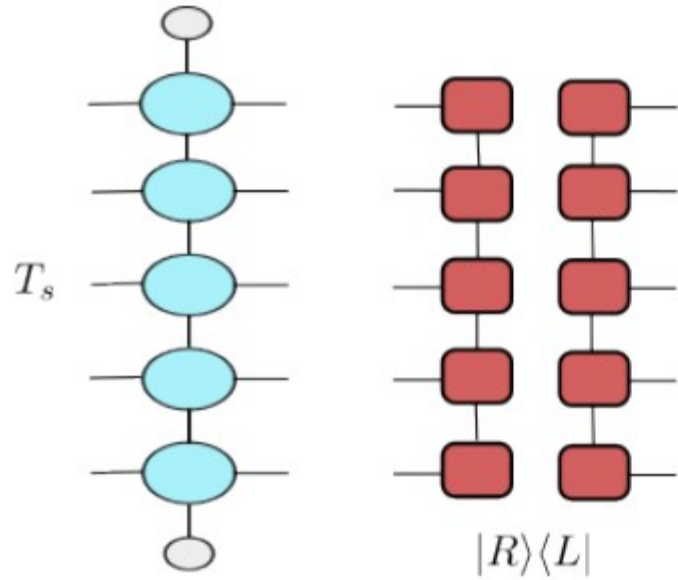

$$T_s = \sum_i e^{\lambda_i} |R_i\rangle\langle L_i|$$

$$l \sim -\frac{|\lambda_0|}{T}$$

$$\mathcal{T}_t^{L|R} = \text{tr}_{N_t-t} [\mathcal{T}^{L|R}], \quad \mathcal{T}^{L|R} = \frac{|R\rangle\langle L|}{\langle L|R\rangle},$$

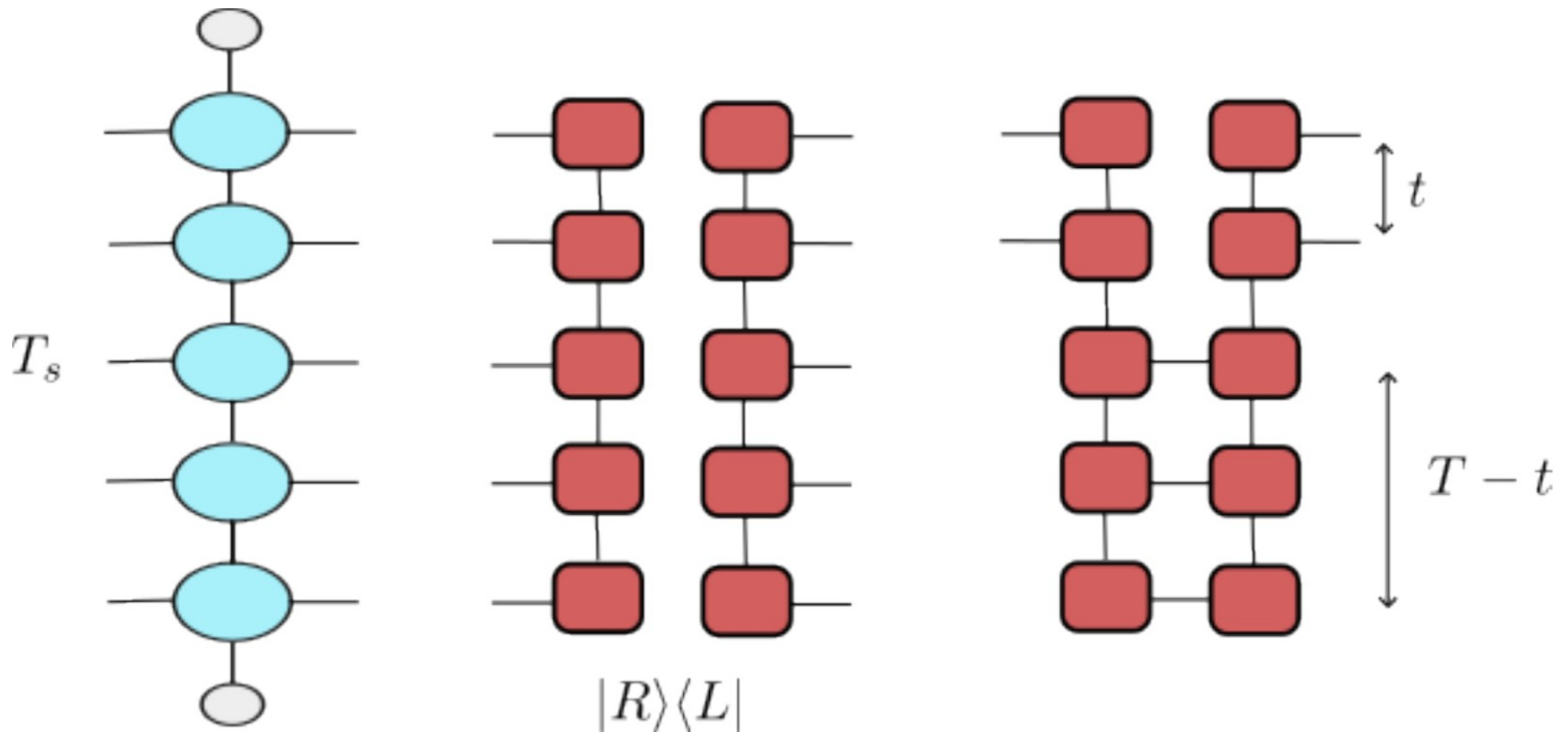



Upper bounding the rank of the reduced transition matrices

with S. Carignano C. Ramos arXiv:2307.11649 (PRR 2024)

d) $\langle \psi_0 | U(T) | \psi_0 \rangle_{\text{CFT}}$:

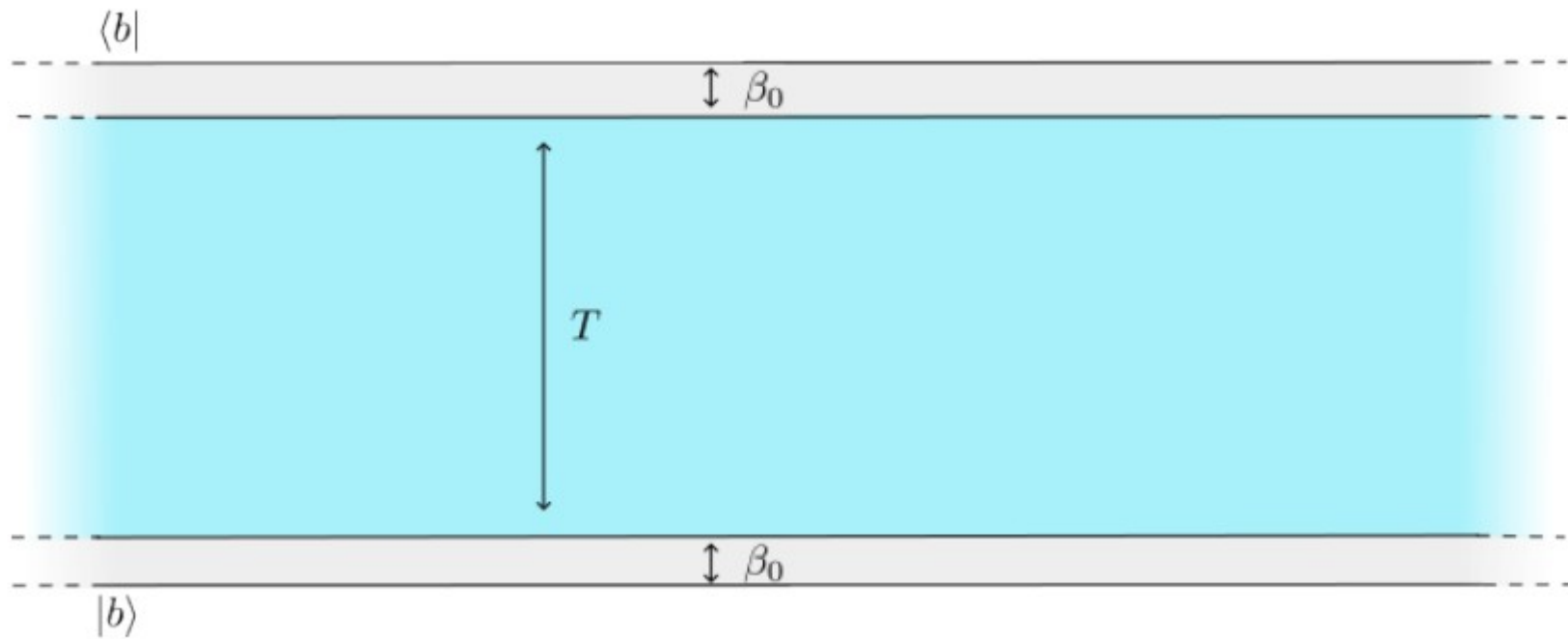

Temporal entropies

$$\mathcal{T}_t^{L|R} = \text{tr}_{N_t-t} \left[\mathcal{T}^{L|R} \right],$$

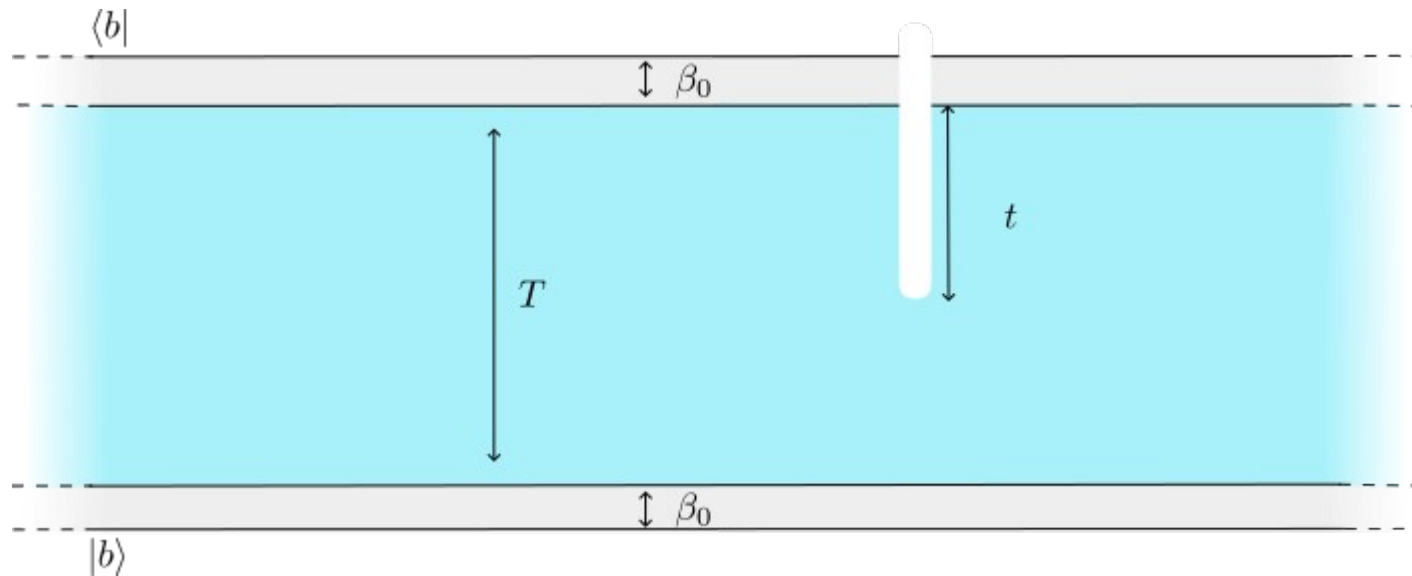

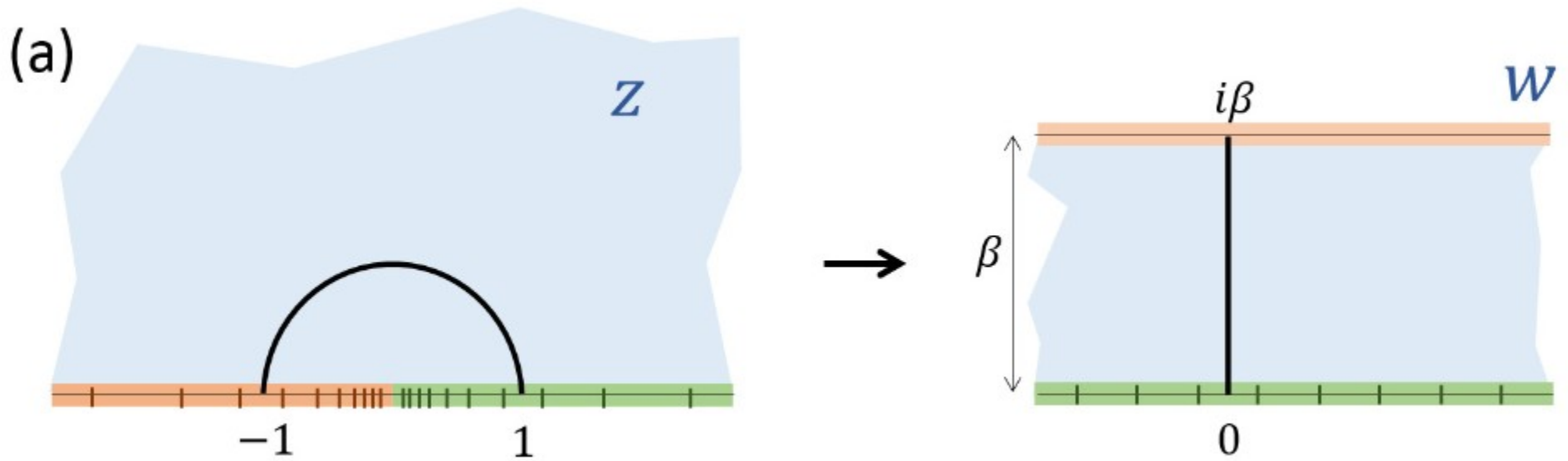

$$w = \beta/\pi \log(z)$$

Czech et al 2015

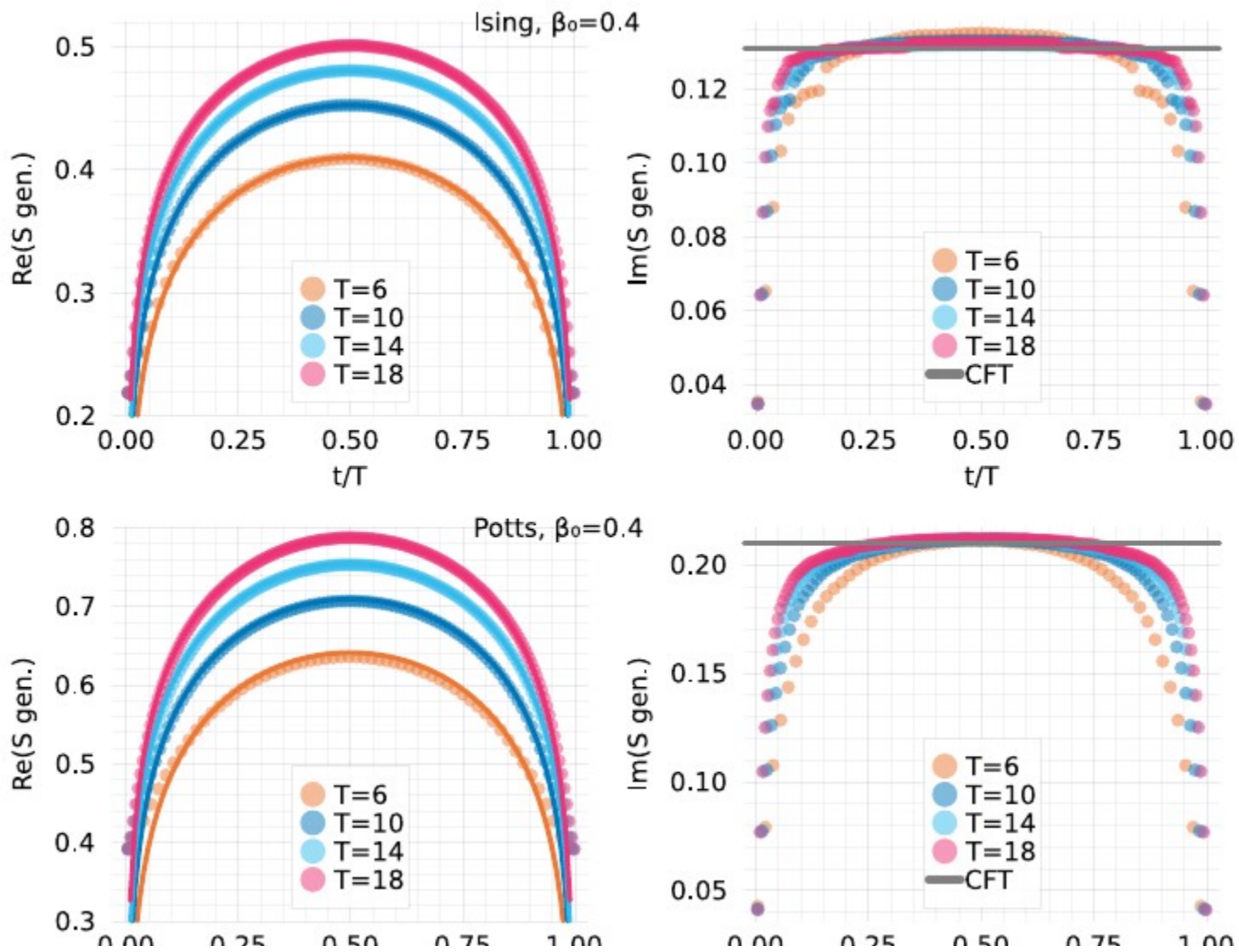

$$S_{gen} = s_0 + \frac{i\pi c}{12} + \frac{c}{6} \log \left[\frac{2T}{\pi} \sin \left(\frac{\pi t}{T} \right) \right],$$

Area Law of temporal entropies

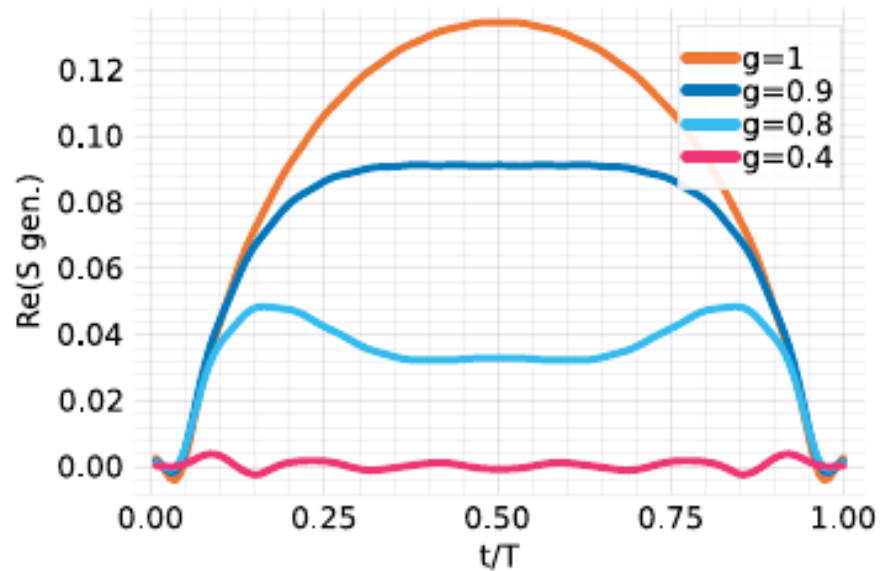
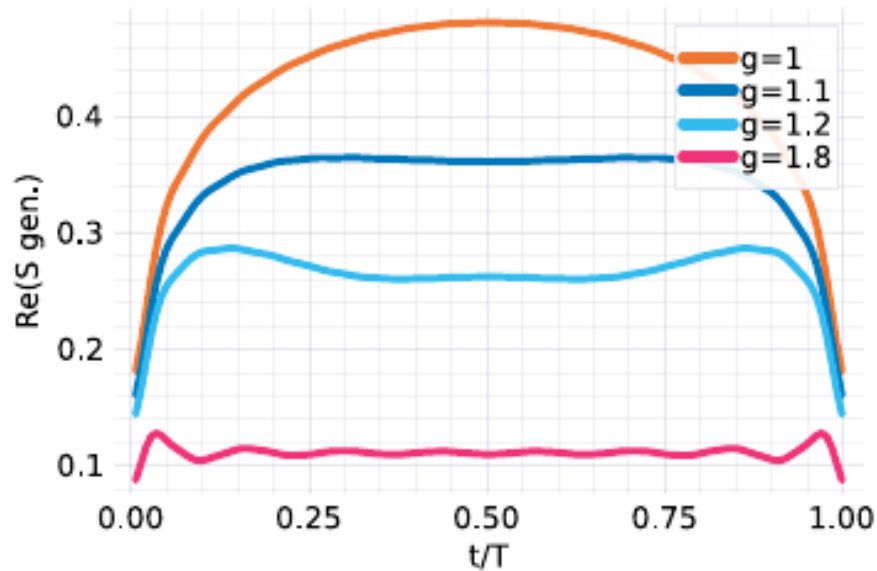

- 
- Generalized temporal entropies grow at most logarithmically
 - LE can be simulated for long time with polynomial resources,
 - Wave function amplitudes behave similarly to LE, their GTE increase at most logarithmically
 - Thus we can efficiently contract them and perform MC sampling [arxiv:2505.09714](https://arxiv.org/abs/2505.09714)

- 
- Out of equilibrium
 - Spatio-temporal tensor networks
 - Entanglement barrier
 - MC sampling and transverse contraction
 - Sampling amplitudes
 - The boundary states
 - Scaling of generalized temporal entropies with time(CFT)
 - Trading entanglement for mixture
 - Unveiling local equilibration
 - Identifying fast degrees of freedom
 - Relation with decoherence
 - Conclusions

Trading entanglement for mixture

- Surace Piani Tagliacozzo PRB2019

Luca Tagliacozzo, OED for HEP CERN 25



$$\lambda_{dB} = \frac{h}{mv}$$

$$mv^2 \sim k_B T$$

$$\lambda_{dB} \sim \frac{h}{\sqrt{mk_B T}} \cdot$$

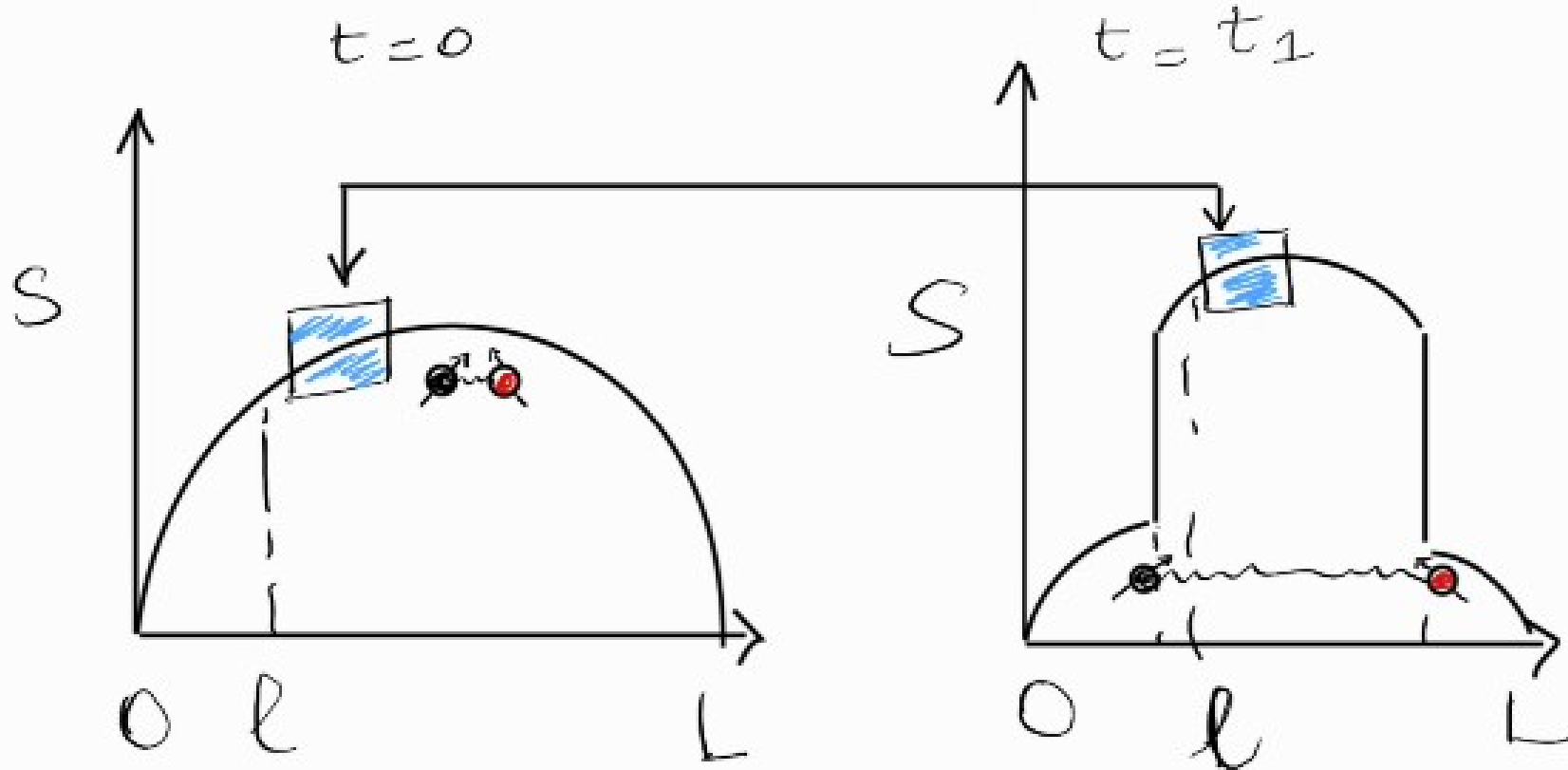



TN and local equilibration

with M Frias-Perez and MC Bañuls (MPQ),
arXiv:2308.04291 (PRL 2024)

- 
- Out of equilibrium
 - Spatio-temporal tensor networks
 - Entanglement barrier
 - MC sampling and transverse contraction
 - Sampling amplitudes
 - The boundary states
 - Scaling of generalized temporal entropies with time(CFT)
 - Trading entanglement for mixture
 - Unveiling local equilibration
 - Identifying fast degrees of freedom
 - Relation with decoherence
 - Conclusions

$$|\Psi\rangle = \sum_{\alpha s_\ell \beta} C_{\alpha\beta}^{s_\ell} |\Phi_\alpha^L\rangle |s_\ell\rangle |\Phi_\beta^R\rangle$$

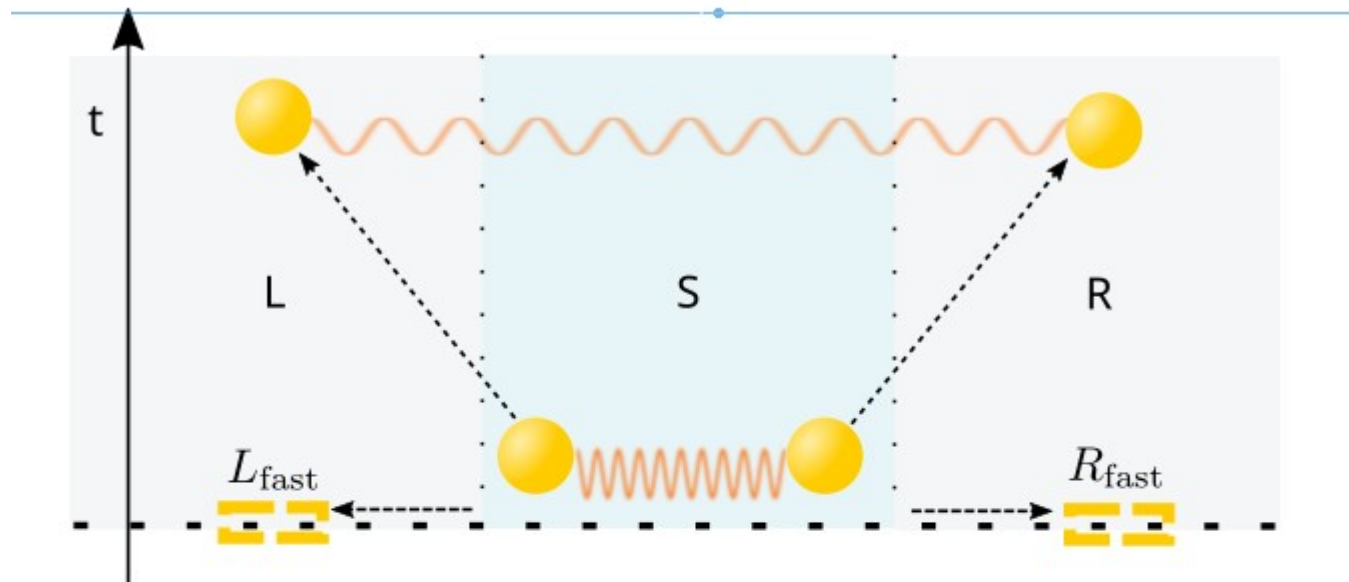
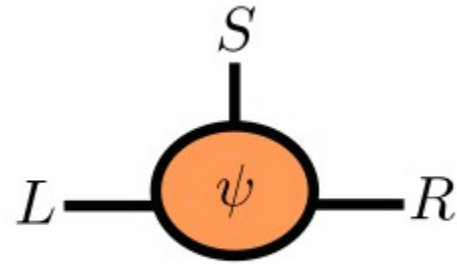

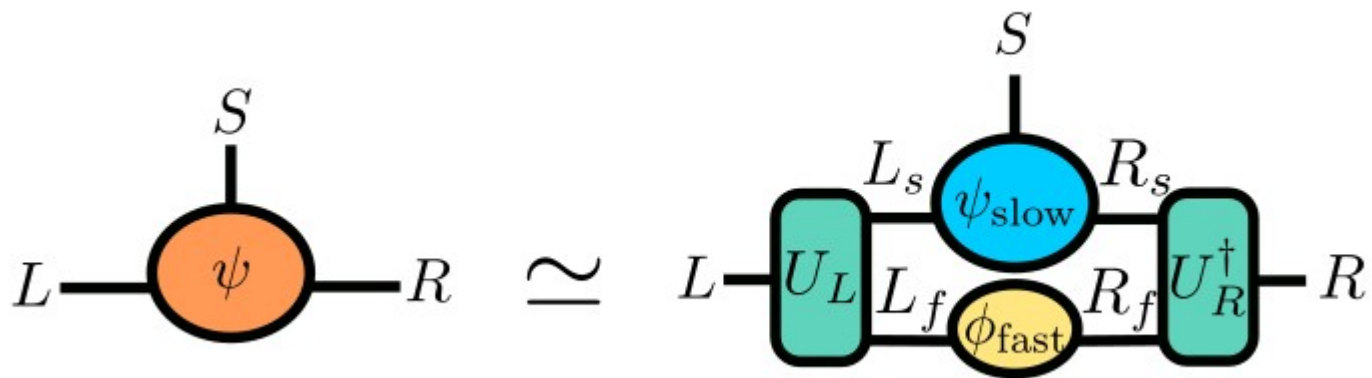
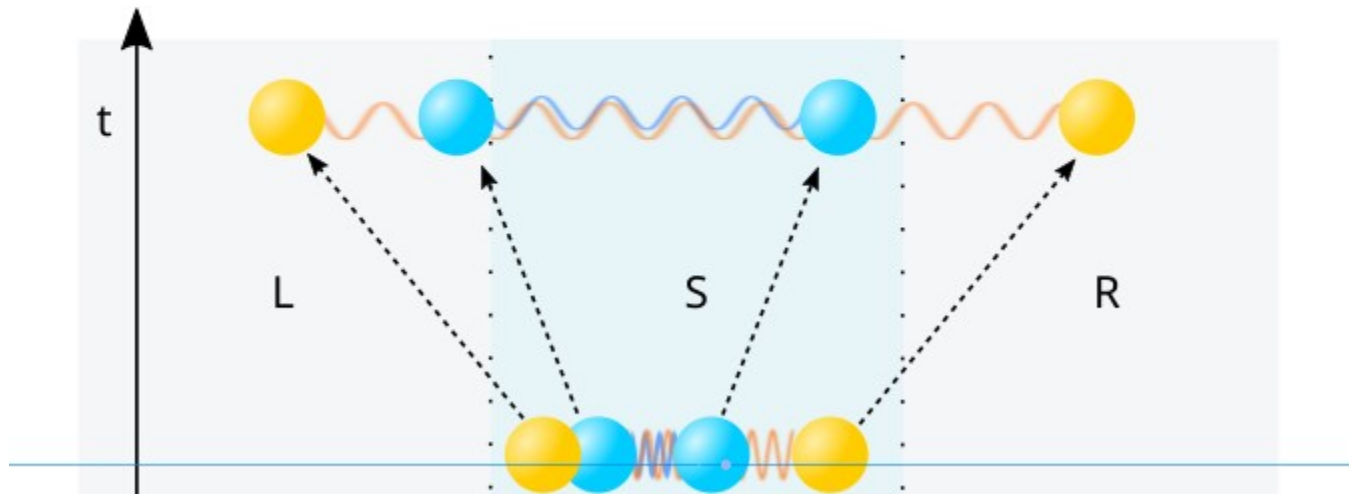

$$U_L^\dagger \otimes \mathbb{1}_S \otimes V_R^\dagger |\Psi\rangle = |\psi_{L_s} S R_s\rangle \otimes |\phi_{L_f} R_f\rangle$$

- 
- Out of equilibrium
 - Spatio-temporal tensor networks
 - Entanglement barrier
 - MC sampling and transverse contraction
 - Sampling amplitudes
 - The boundary states
 - Scaling of generalized temporal entropies with time(CFT)
 - Trading entanglement for mixture
 - Unveiling local equilibration
 - Identifying fast degrees of freedom
 - Relation with decoherence
 - Conclusions

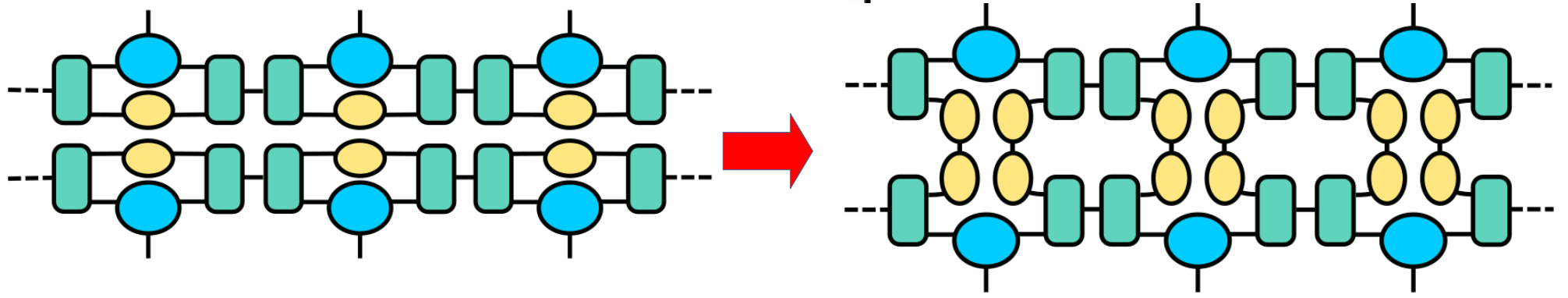
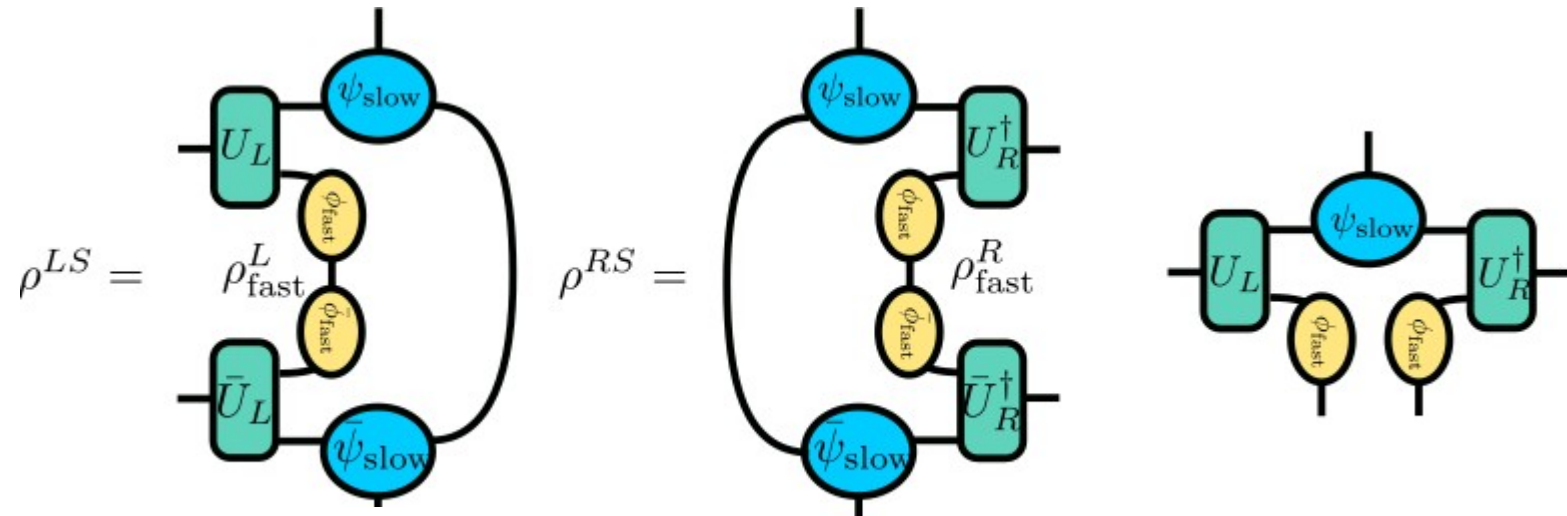
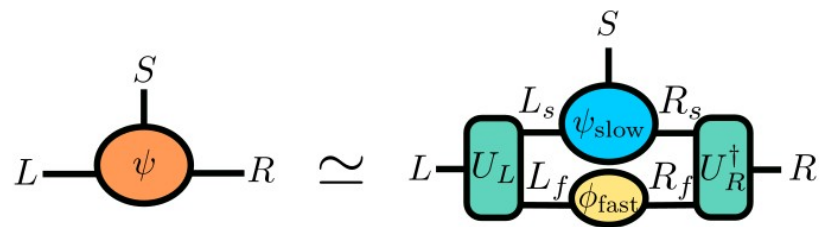



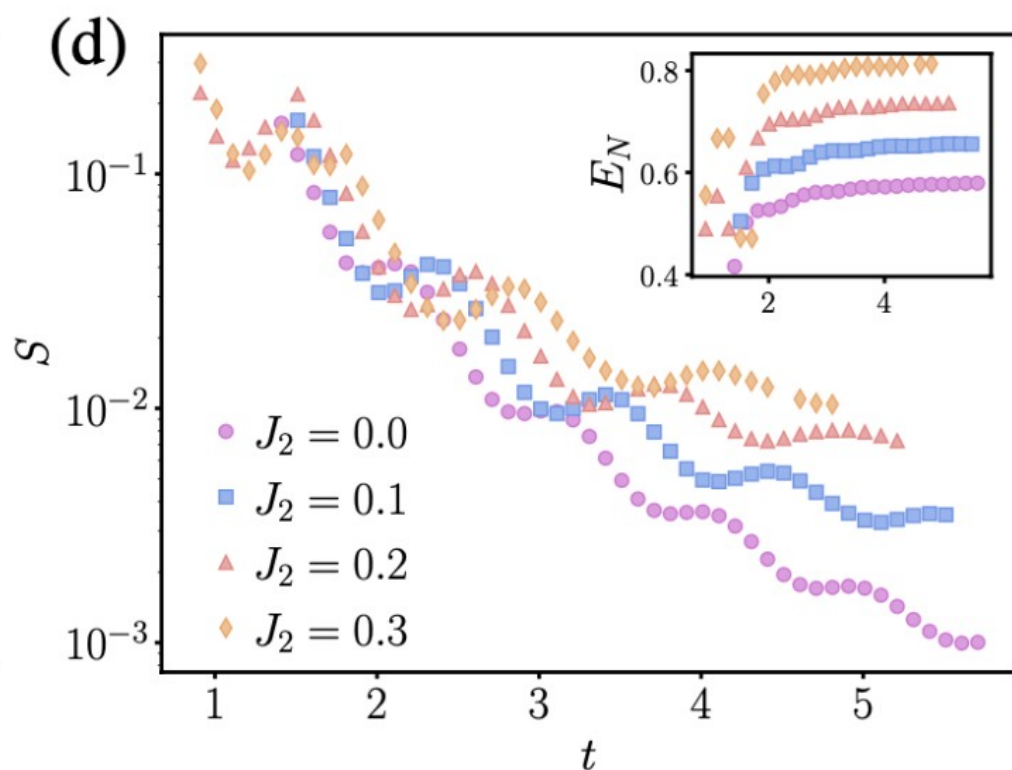
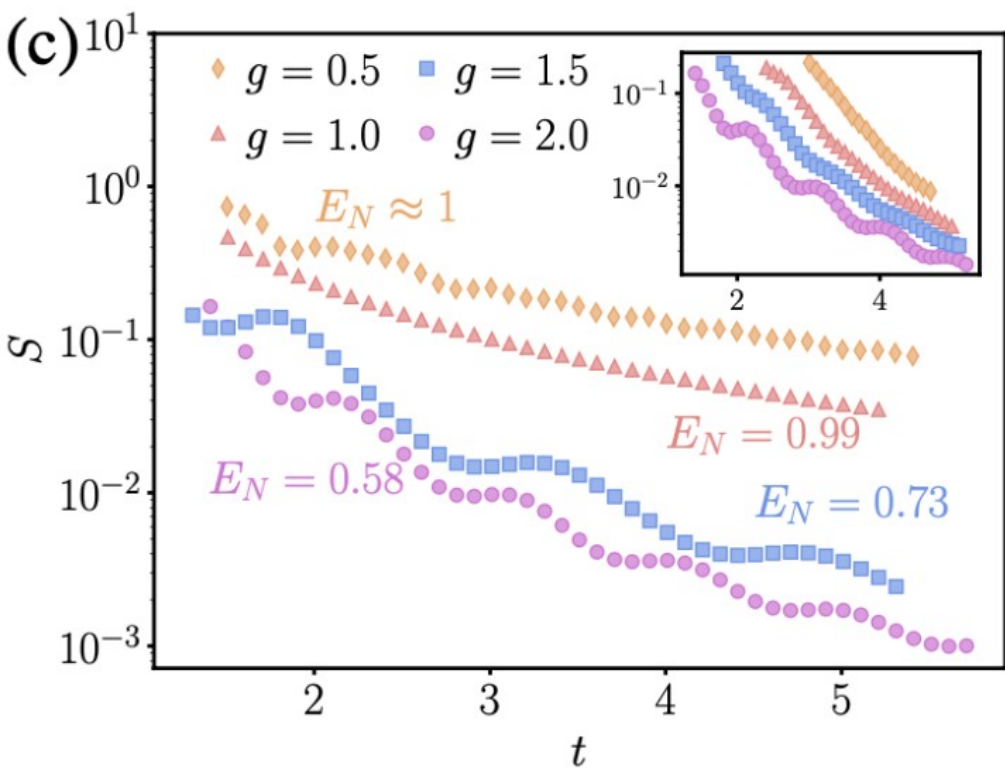
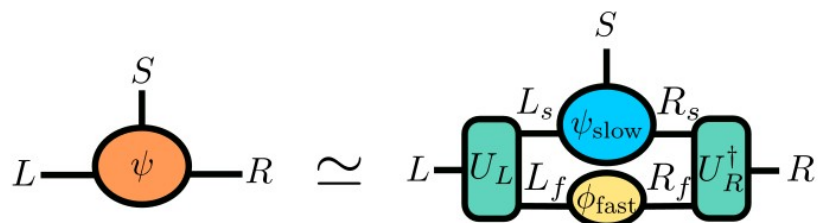
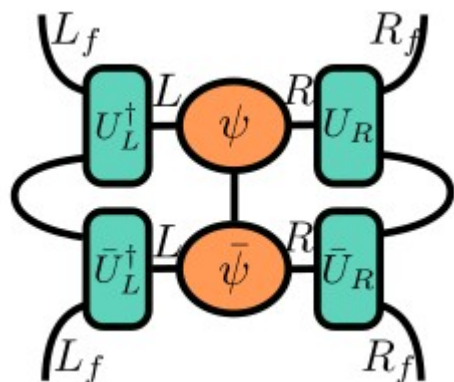

Numerical results

$$H = - \sum_i \left(\sigma_i^z \sigma_{i+1}^z + g \sigma_i^x + J_2 \sigma_i^z \sigma_{i+2}^z \right)$$

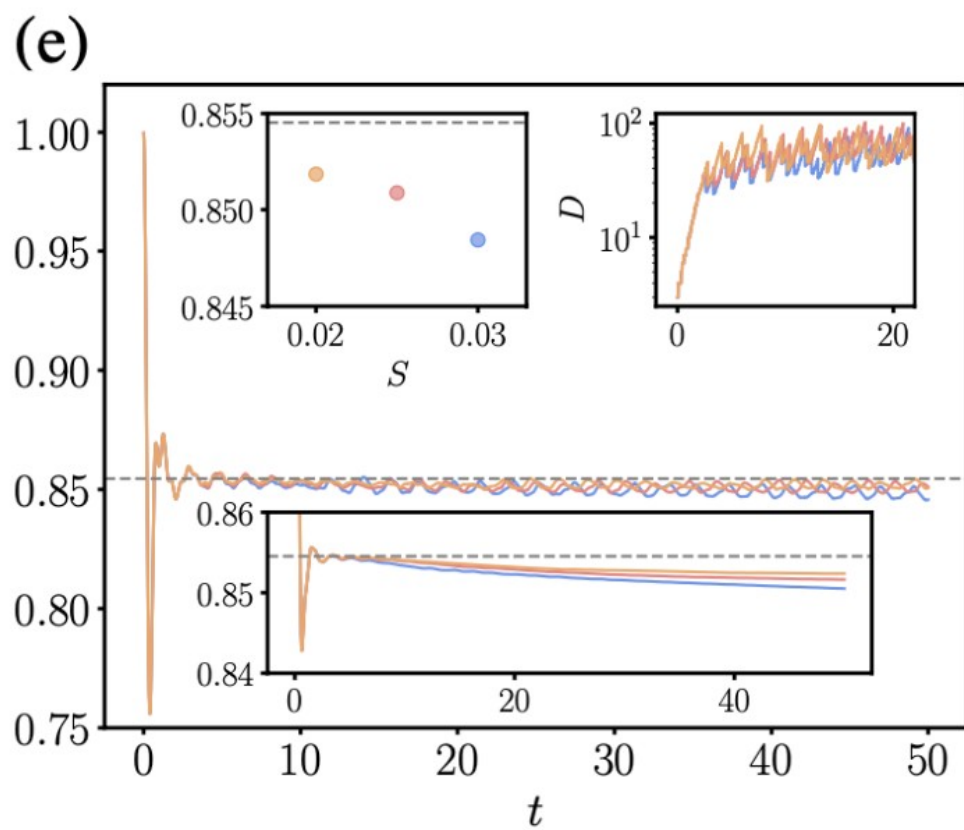
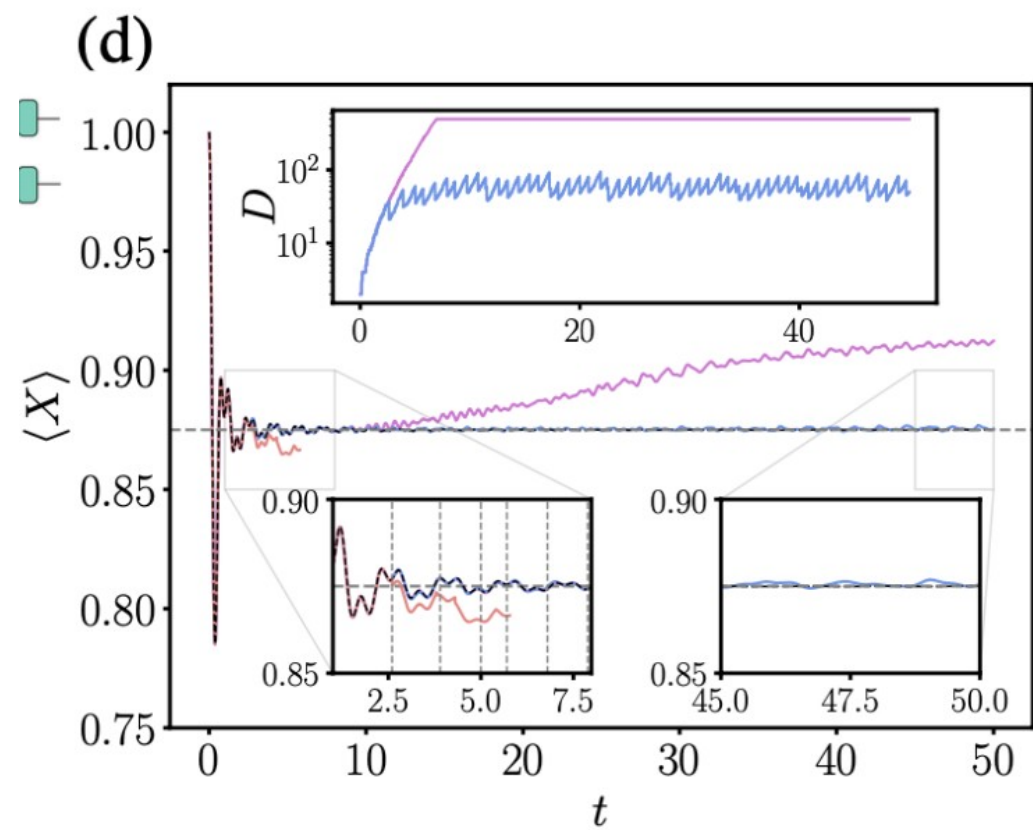



- 
- The entanglement barrier in 1D **can be circumvented**
 - Either we need to perform MC sampling of wavefunction amplitudes and find a strategy to contract those efficiently
 - Add **Decoherence**, which allows to reach long times at finite computational resources

Happy to host MC fellows, JdC, RyC



luca.tagliacozzo@iff.csic.es



Luca Tagliacozzo, OED for HEP CERN
25



Upper bounding temporal entanglement

with S. Carignano C. Ramos arXiv:2307.11649

$$\langle \psi_0 | O(T) | \psi_0 \rangle$$

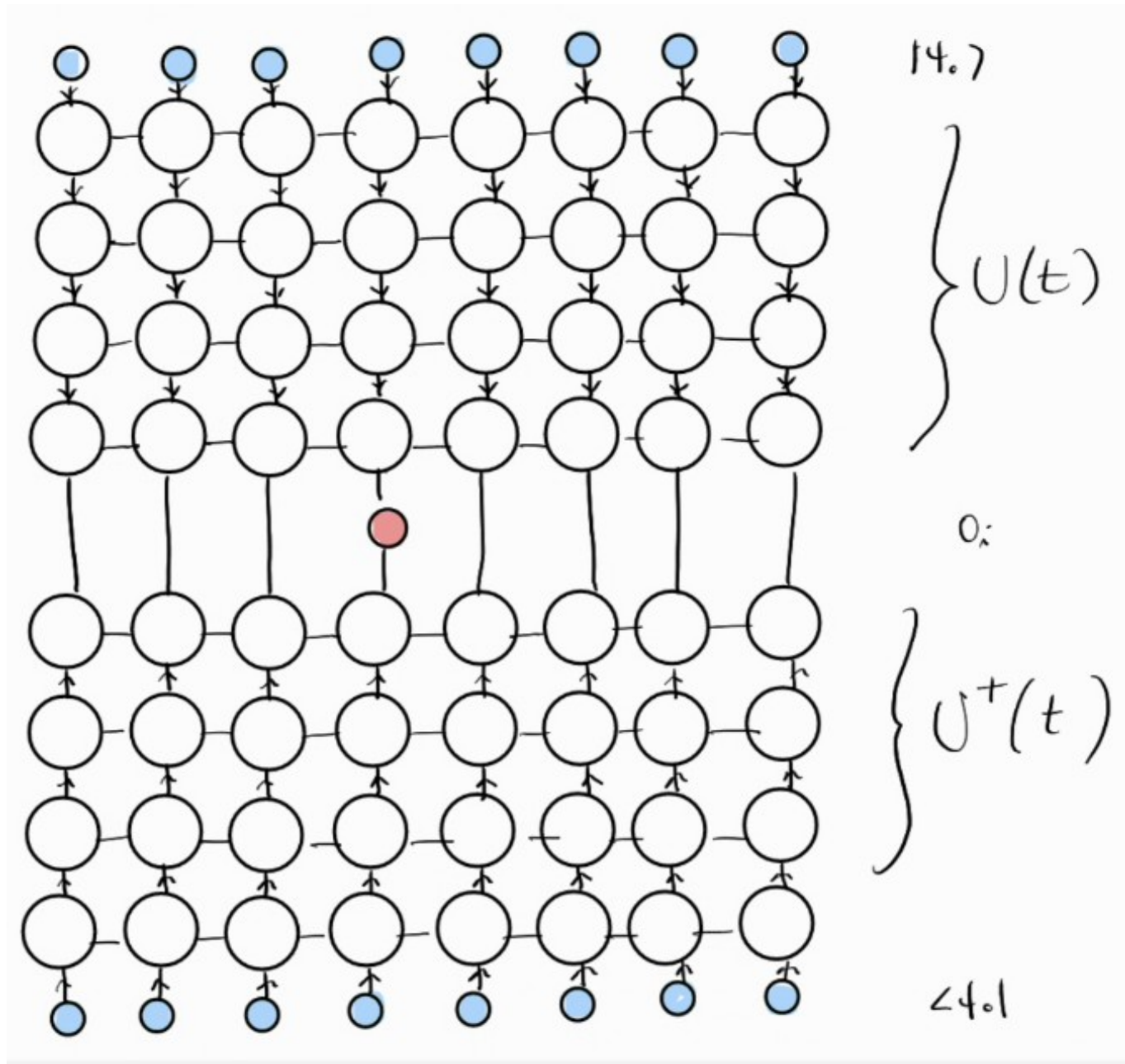

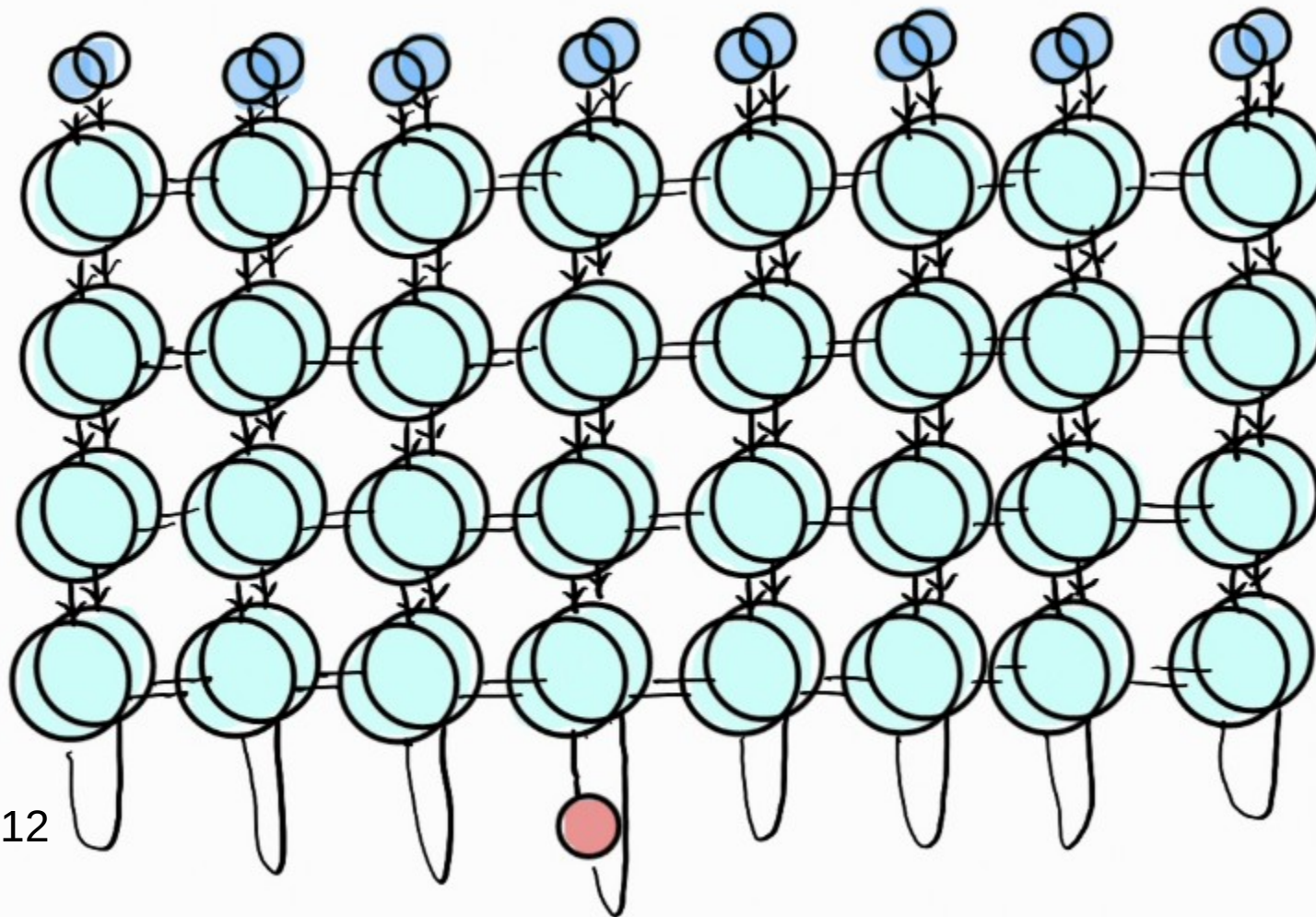

Bañuls et al. 2009
Muller Hermes et al 2012
Hastings et al. 2015
Tirrito et al (LT) 2018
Lerose et al 2021
Giudice et al 2021....

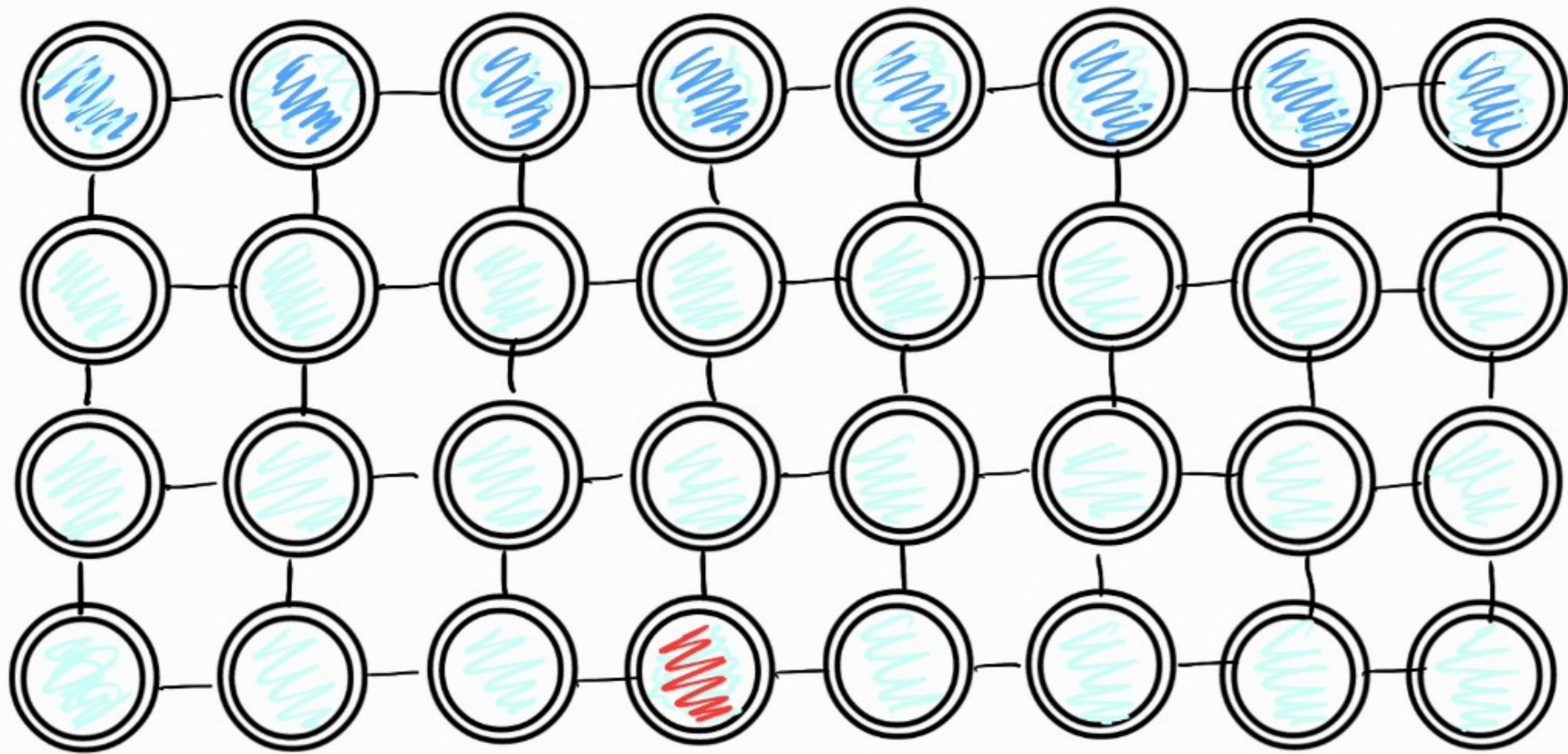

$$\langle \psi_0 | U^\dagger(t) O_i U(t) | \psi_0 \rangle$$

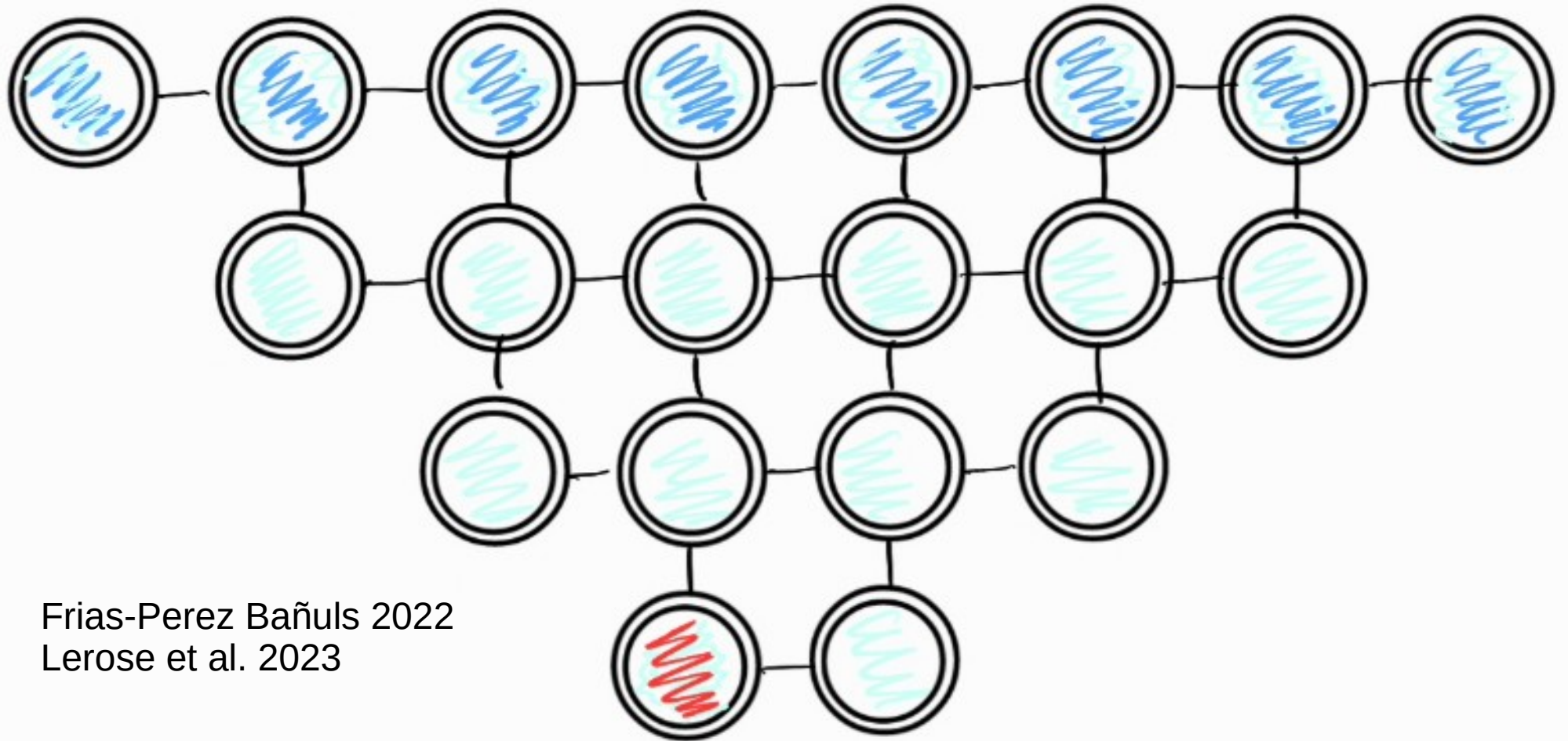

Frias-Perez Bañuls 2022
Lerose et al. 2023

$$\langle \psi_0 | U^\dagger(t) Q U(t) | \psi_0 \rangle$$

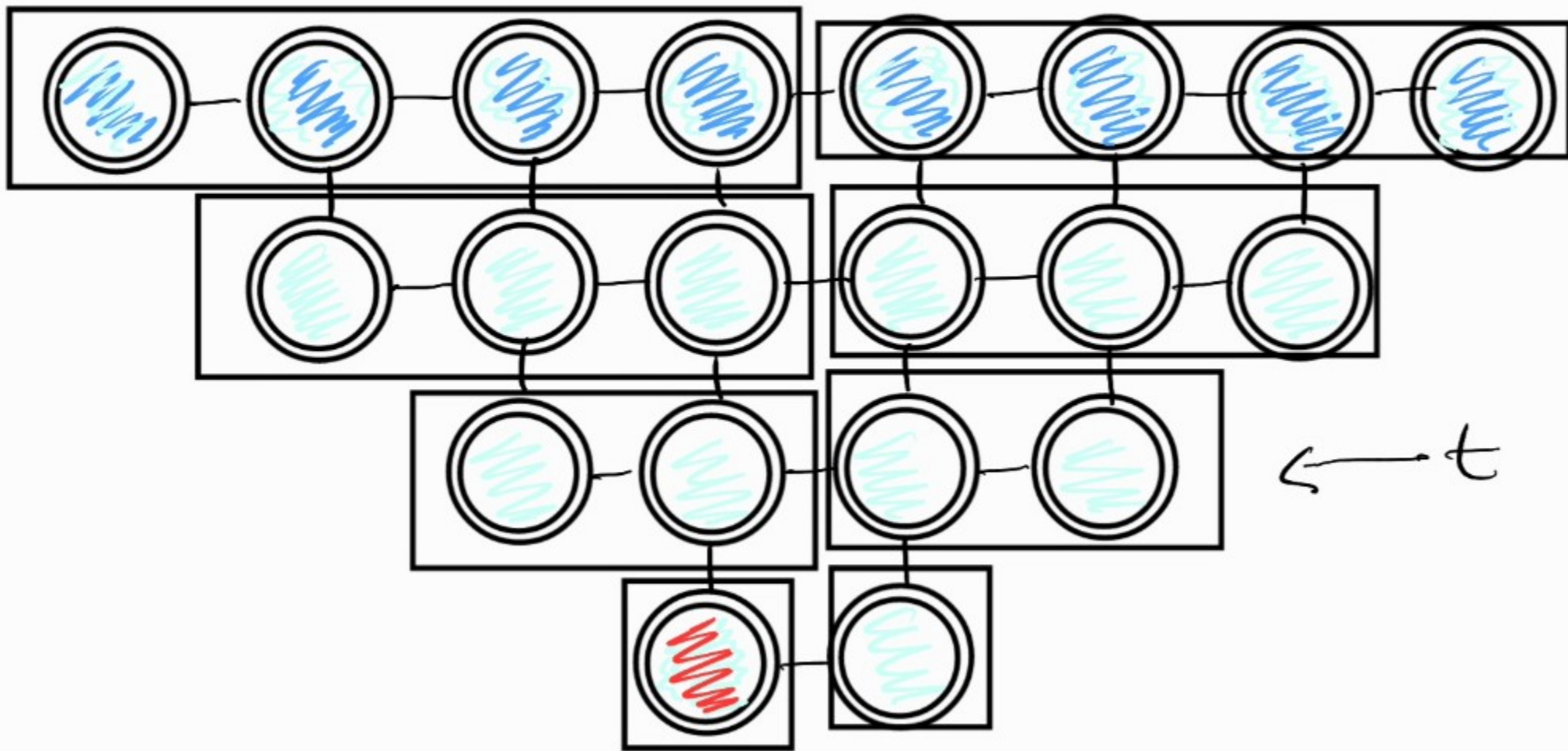

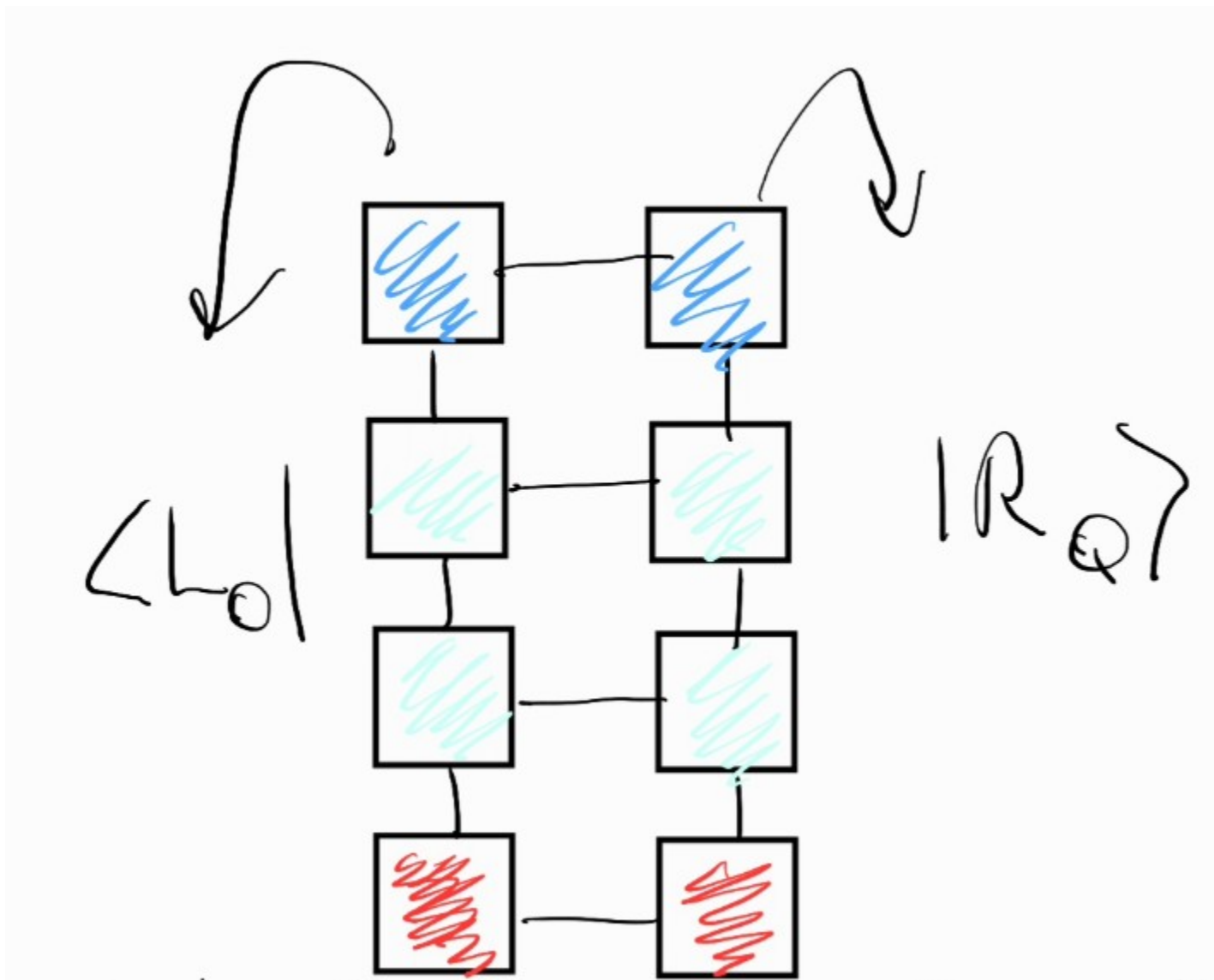

temporal MPS, tMPS



t

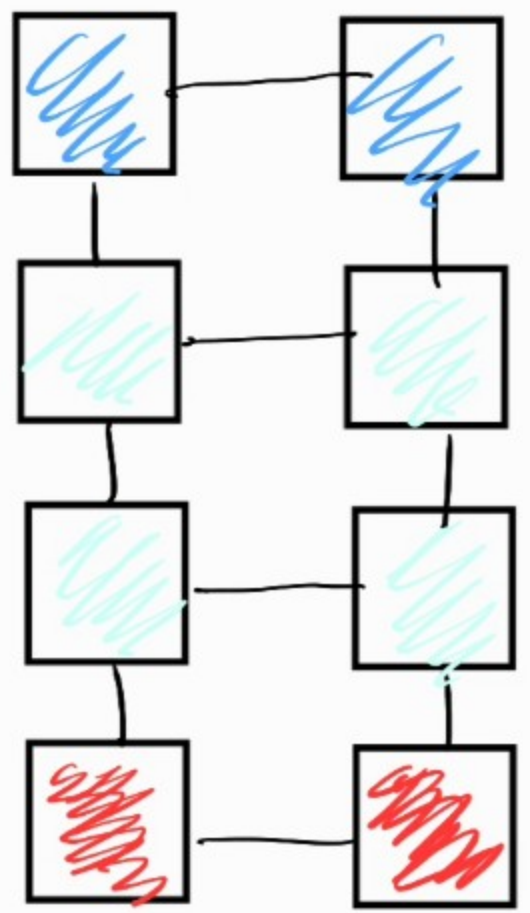

$t + \delta t$

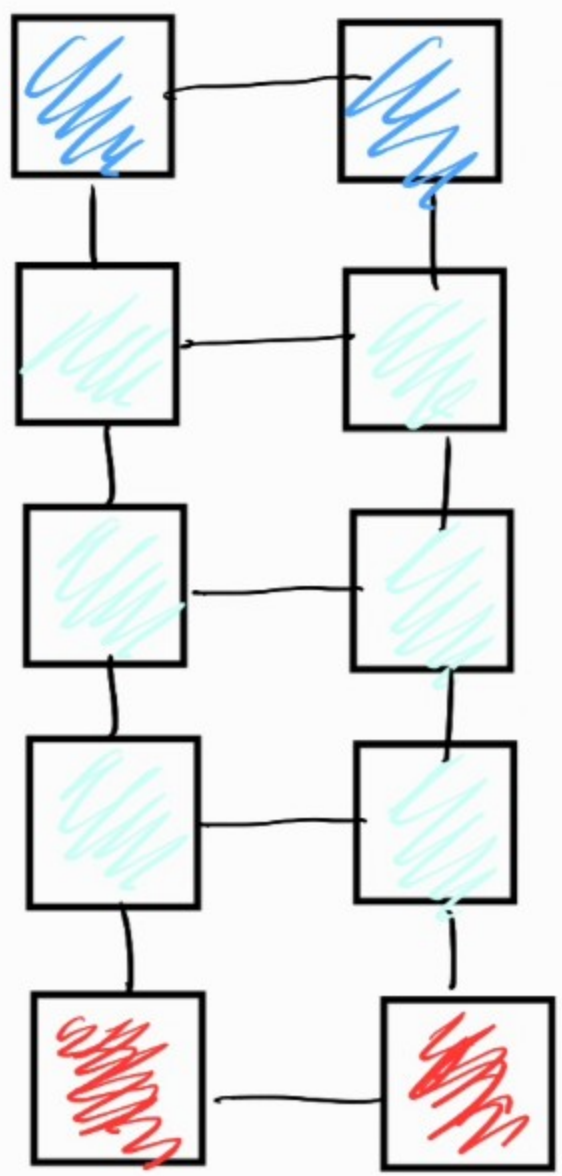

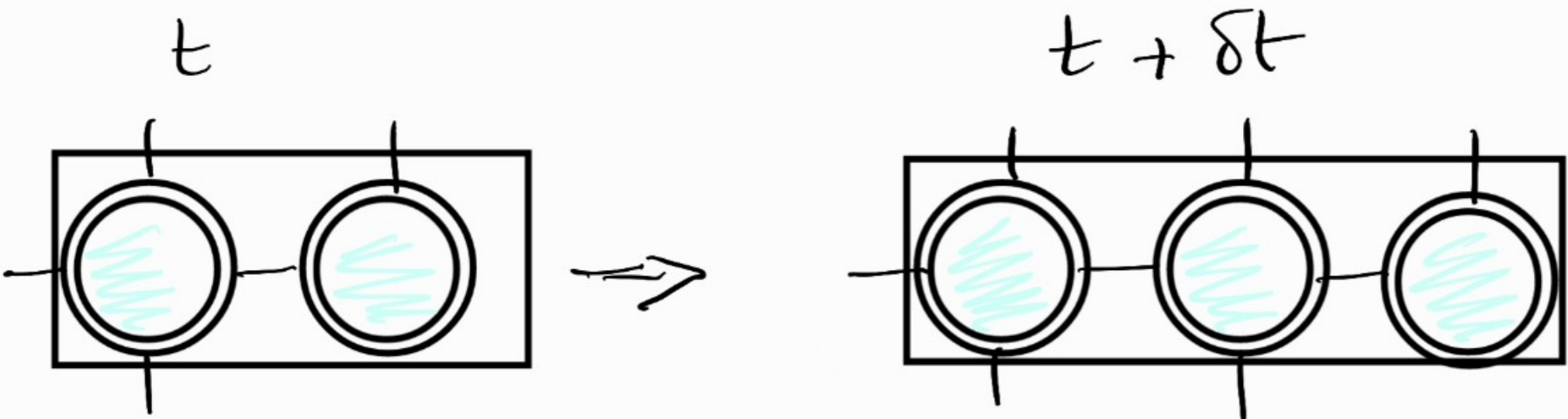

What is the actual computational cost?

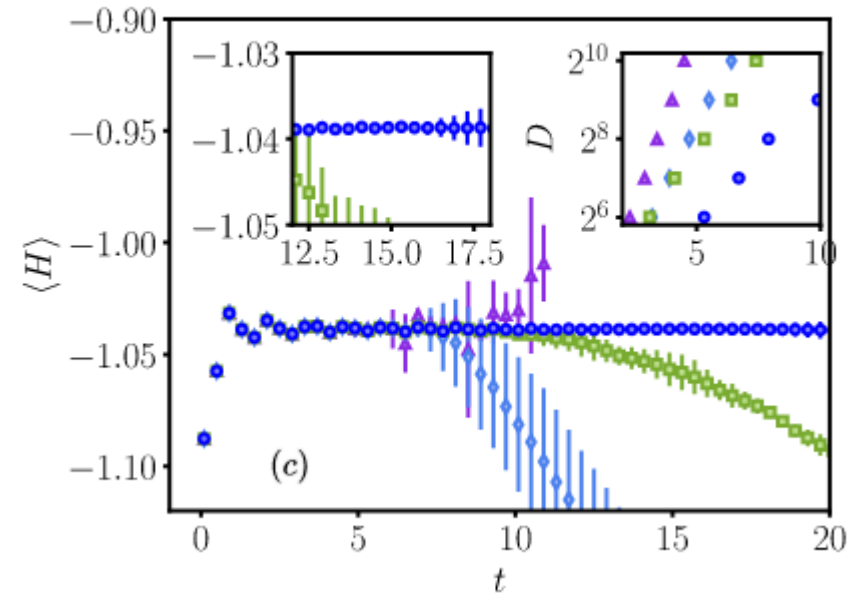
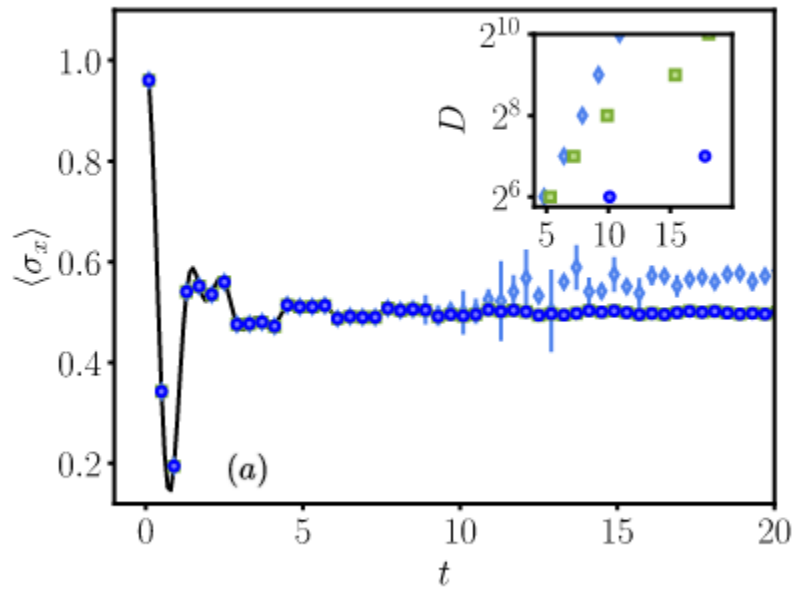

from Frias-Perez Bañuls 2022

- 
- Out of equilibrium
 - Entanglement barrier
 - On temporal entanglement
 - The transition matrix T
 - T low rank approximation
 - The upper bound to the rank of T
 - Quasi-particles
 - Trading entanglement for mixture
 - Unveiling local equilibration
 - Identifying fast degrees of freedom
 - Relation with decoherence

Transition Matrix

$$Z_{\text{Rpice}} \times L_{\text{oil}} =$$

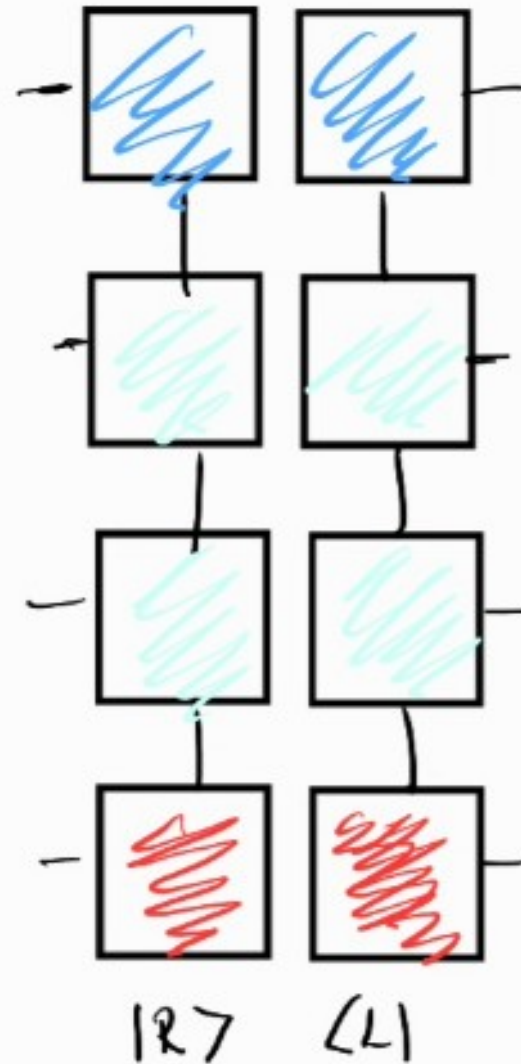

Generalized entropies

$$\tau^t = \tau \sum_{(I-t)} \frac{\sigma}{R_0 \times L_0}$$

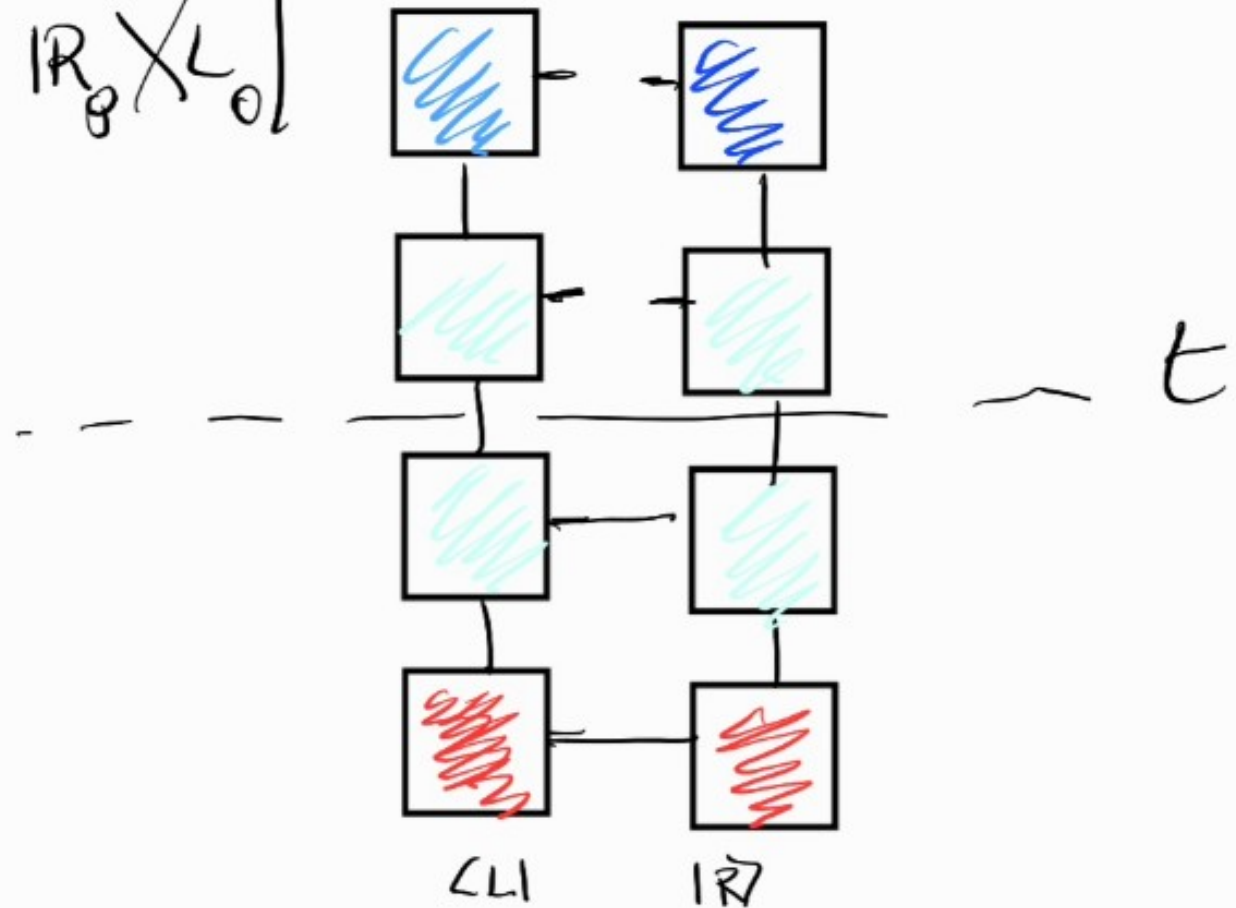

- 
- Out of equilibrium
 - Entanglement barrier
 - On temporal entanglement
 - The transition matrix T
 - T low rank approximation
 - The upper bound to the rank of T
 - Quasi-particles
 - Trading entanglement for mixture
 - Unveiling local equilibration
 - Identifying fast degrees of freedom
 - Relation with decoherence

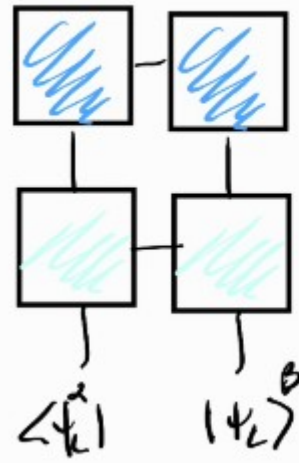
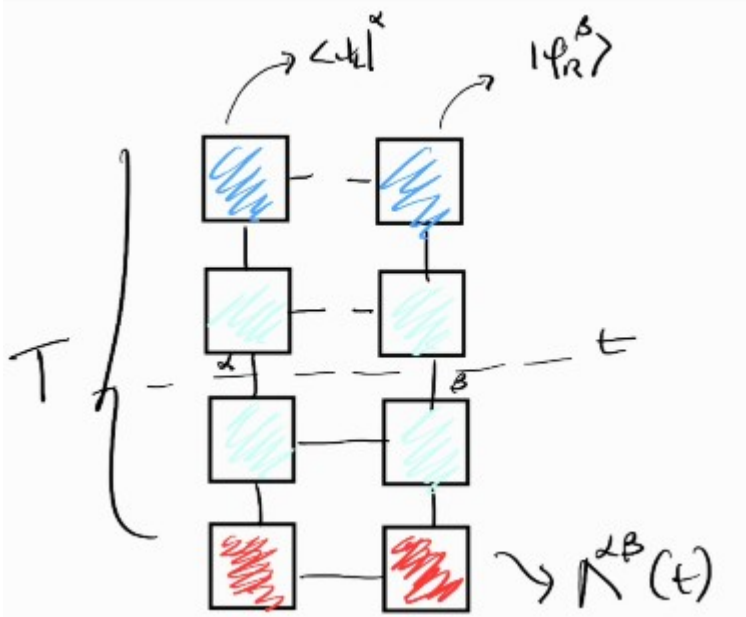

$\bar{\Lambda}_L$

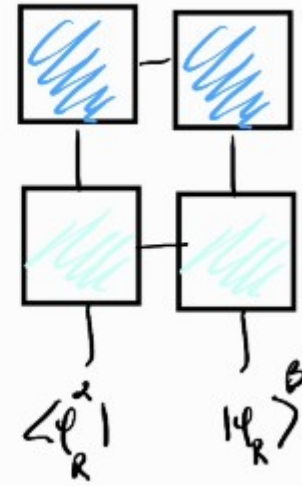

$\bar{\Lambda}_R$

$$\mathcal{T}^t \simeq \sqrt{\bar{\Lambda}_L} \Lambda_t \sqrt{\bar{\Lambda}_R}$$

$$\bar{\Lambda}_L = \bar{\Lambda}_R$$

$$\text{rank}(\mathcal{T}^t) \leq \min \{ \text{rank}(\Lambda_t), \text{rank}(\bar{\Lambda}_L) \}$$

$$\bar{\Lambda}_L$$

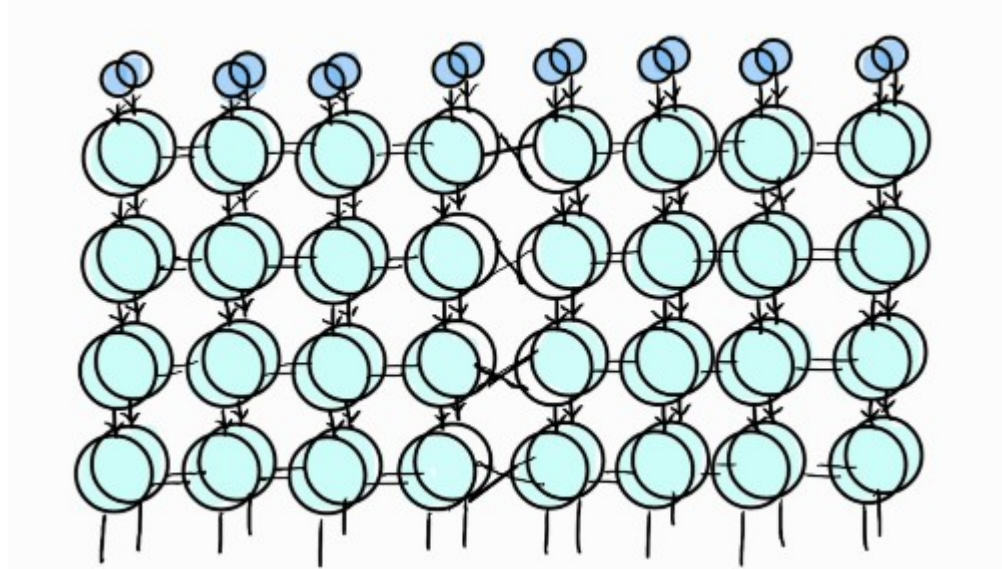

$$\rho(t) T_R$$

$$\text{rank} \left(\bar{\Lambda}_L \right) \propto \exp(t)$$

Λ_t

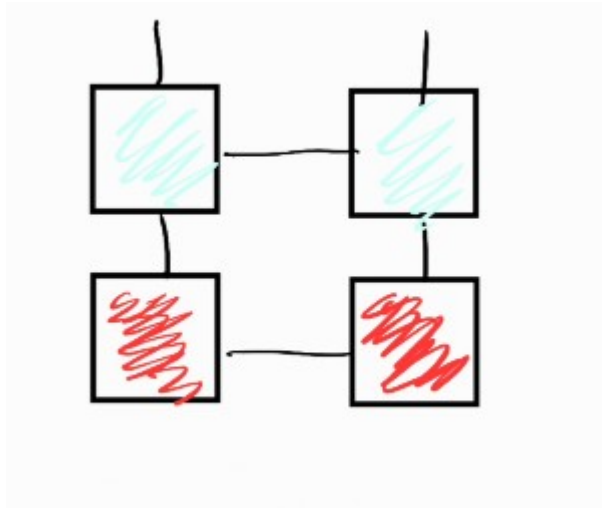

$$O_i(t) = U^\dagger(t) O_i U(t)$$

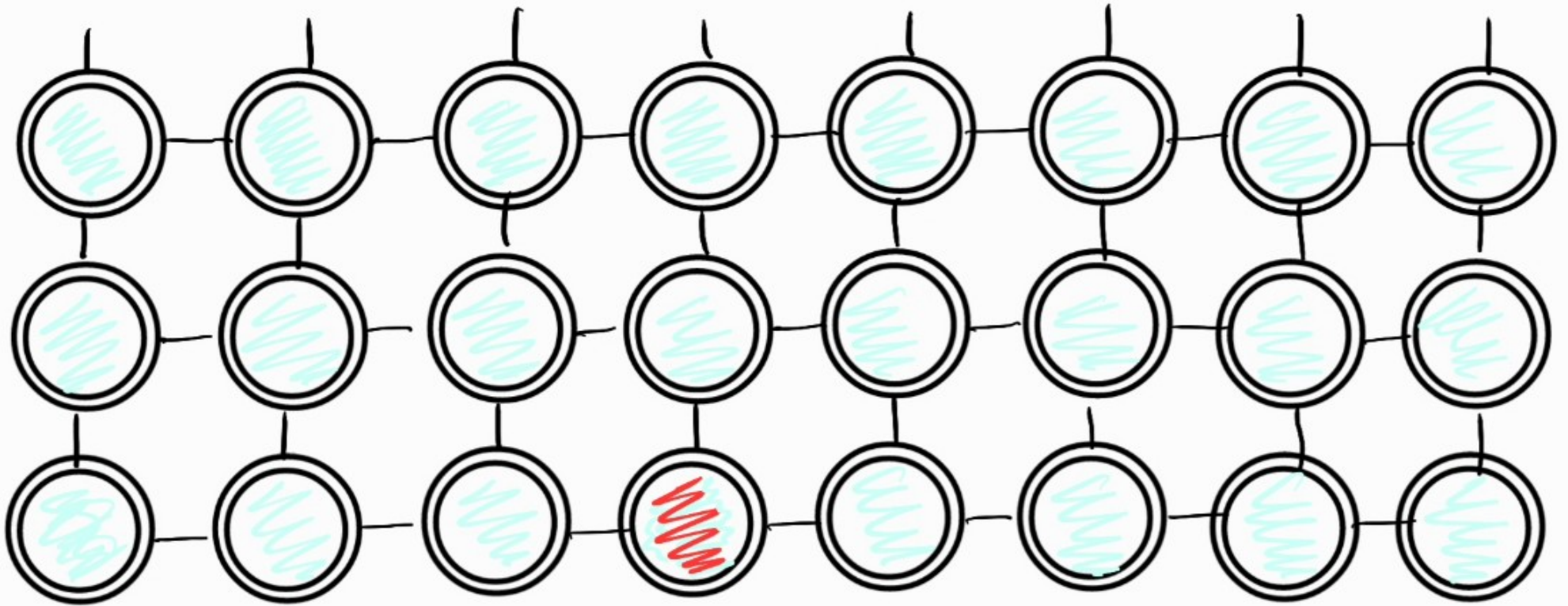

$$O_i(t) = U^T(t) O_i U(t)$$

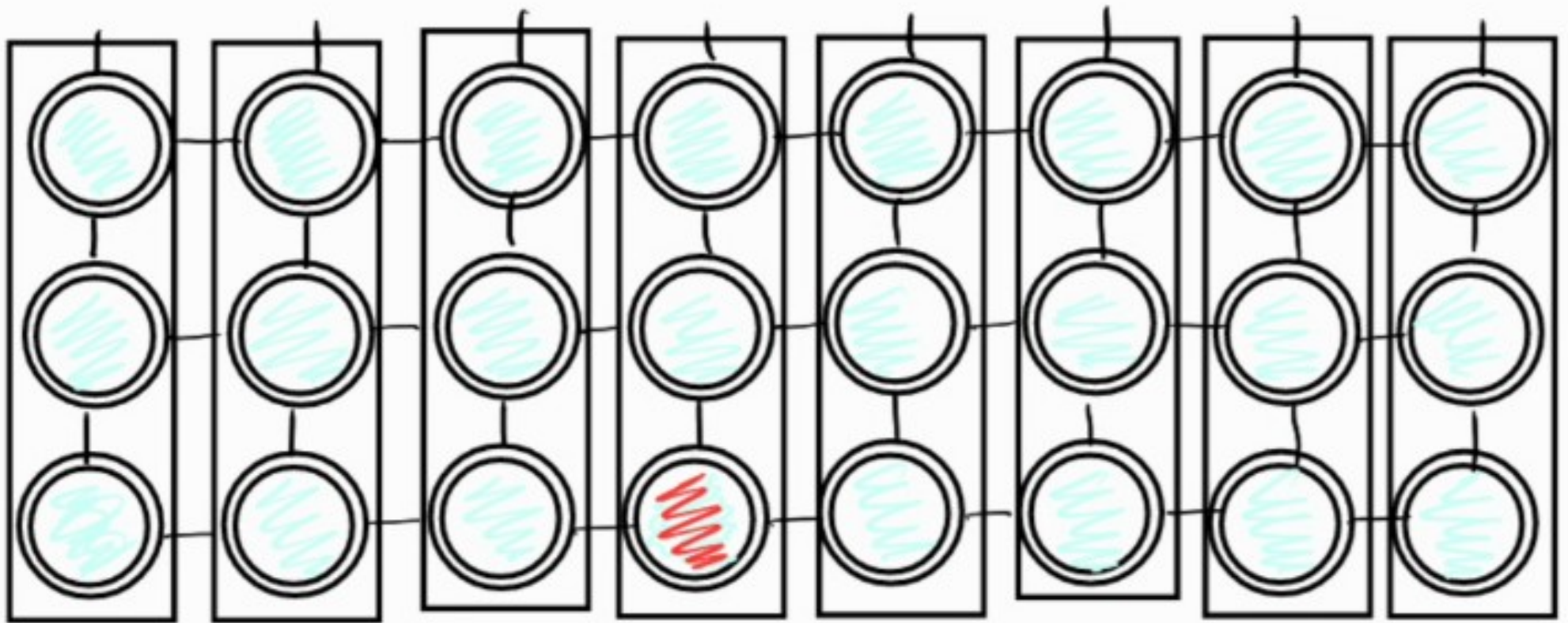

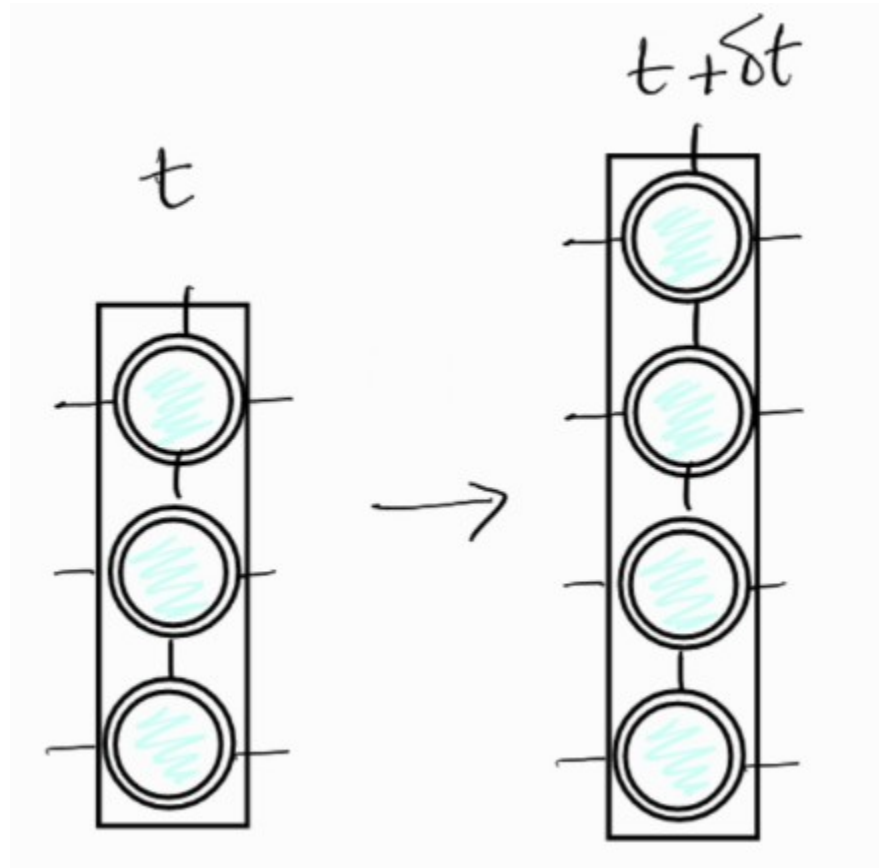

What is the actual computational cost?

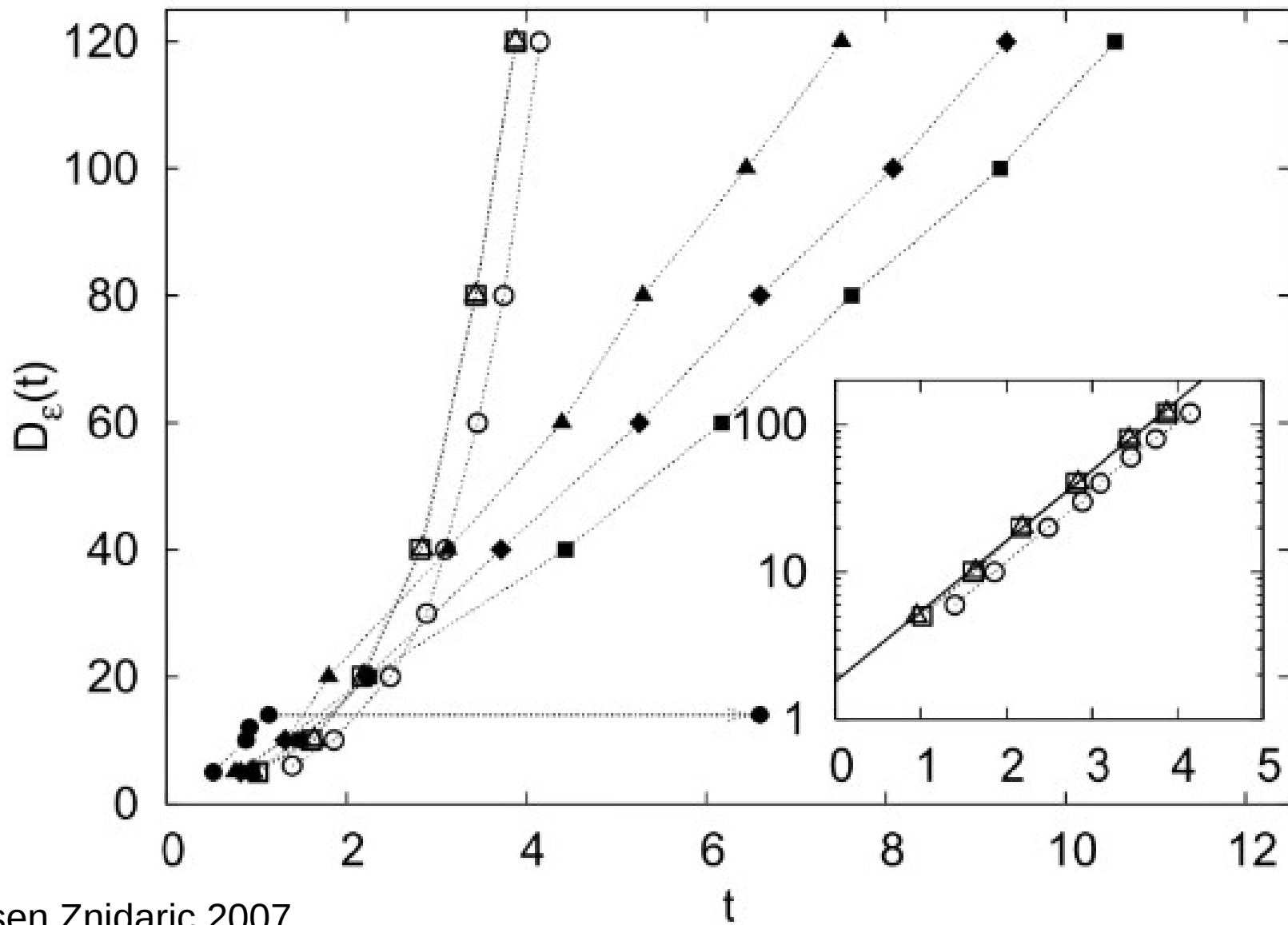

Prosen Znidaric 2007

$$\text{rank} (\mathcal{T}^t) \leq \min \{ \text{rank} (\Lambda_t), \text{rank} (\bar{\Lambda}_L) \}$$

$$\text{rank} (\Lambda^t) \propto t^\alpha$$

$$\text{rank} (\bar{\Lambda}_L) \propto \exp(t)$$



Prosen Znidaric 2007
Pizorn Prosen 2009
Dubail 2017.....

$$\text{rank} (\mathcal{T}^t) \leq t^\alpha$$

$$\text{rank} (\mathcal{T}^t) \leq \min \{ \text{rank} (\Lambda_t) , \text{rank} (\bar{\Lambda}_L) \}$$

$$\text{rank} (\Lambda^t) \propto \exp (t) \qquad \text{rank} (\bar{\Lambda}_L) \propto \exp(t)$$



$$\text{rank} (\mathcal{T}^t) \leq \exp(t)$$

$$H = \sum_i (-X_i X_{i+1} - gZ_i - hX_i)$$

Integrable quench:

$$\{g = \infty, h = 0\} \rightarrow \{g = 0.7, h = 0\}$$

Non-integrable quench:

$$\{g = \infty, h = 0\} \rightarrow \{g = -1.05, h = 0.5\}$$

