



Science and  
Technology  
Facilities Council

RAL Space

**IMPERIAL**



# A high flux Sr source for atom interferometry

Anna Marchant

3<sup>rd</sup> TVLBAI workshop  
Hannover, August 2025

# Why a Sr source?

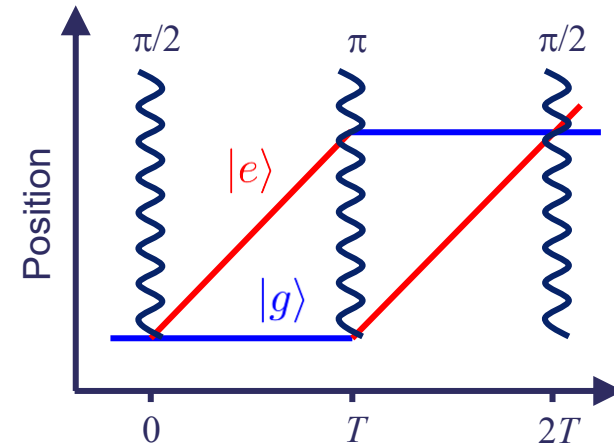
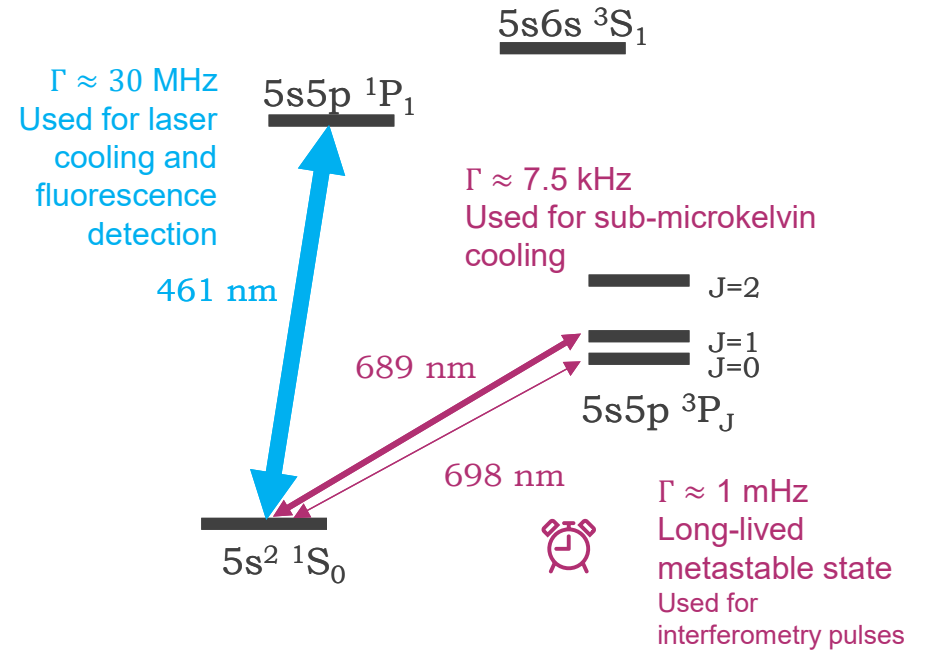
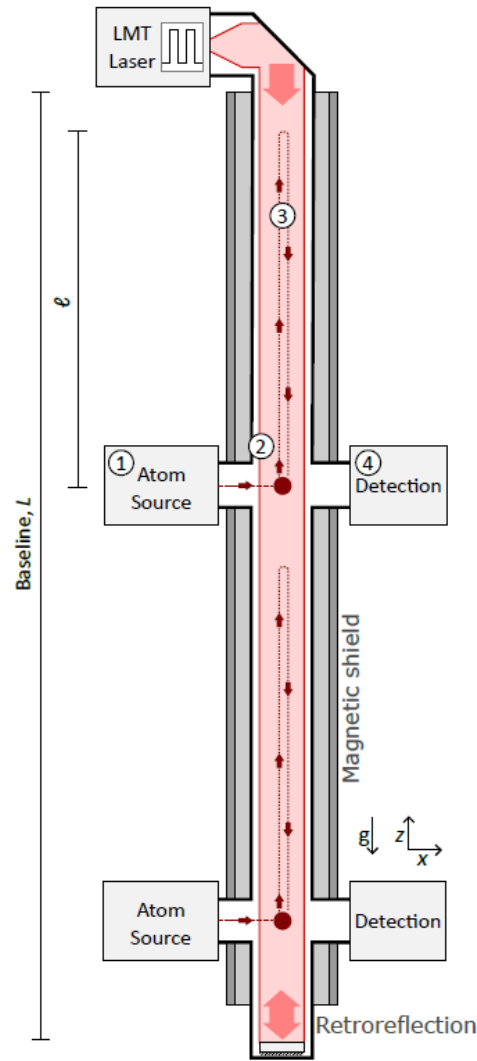
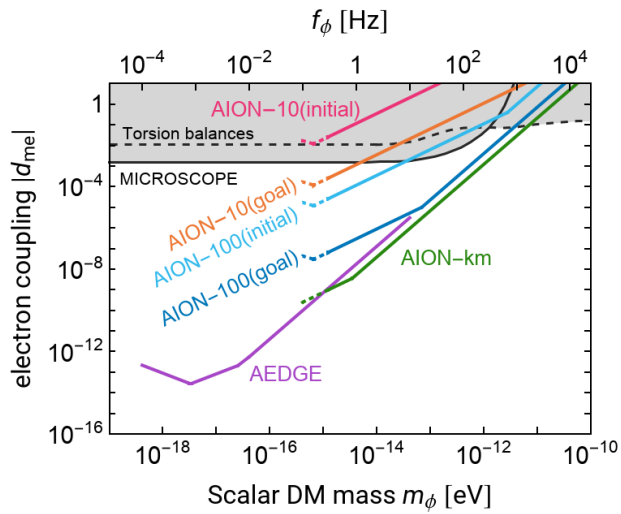
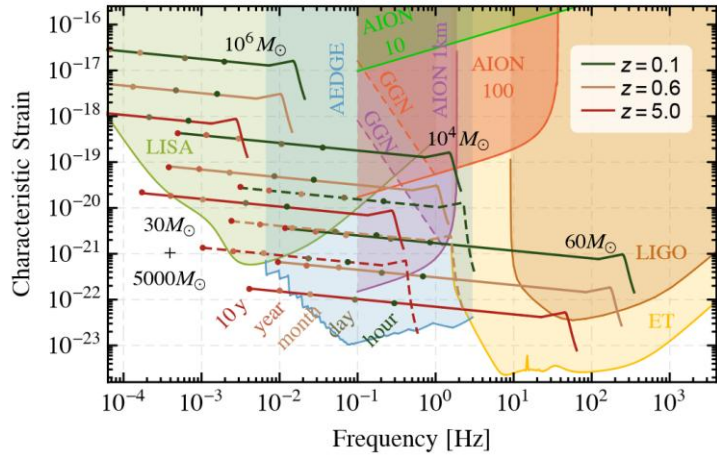

Use single photon clock transition to reduce laser phase noise

# AION – Atom Interferometer Observatory and Network

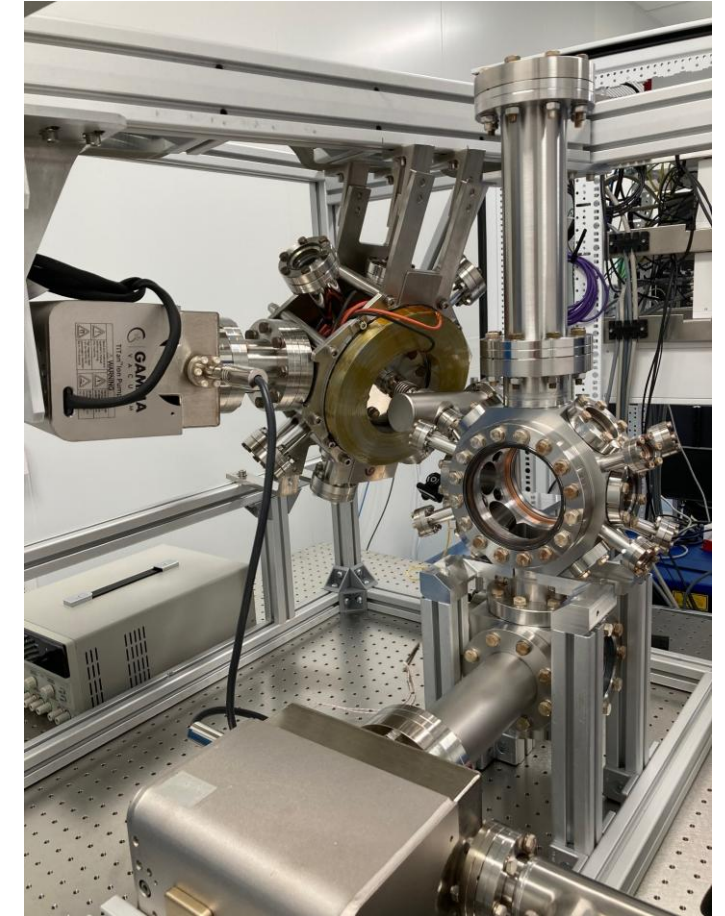
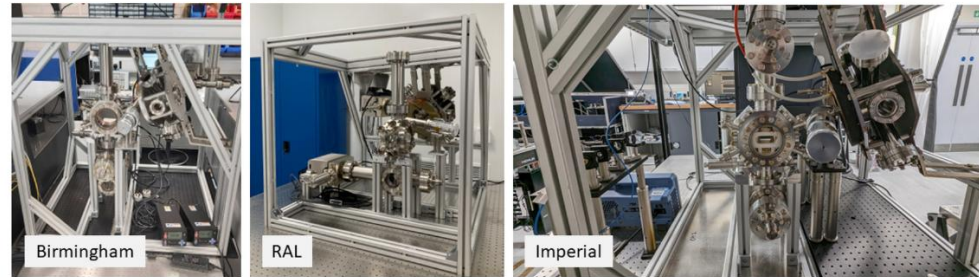
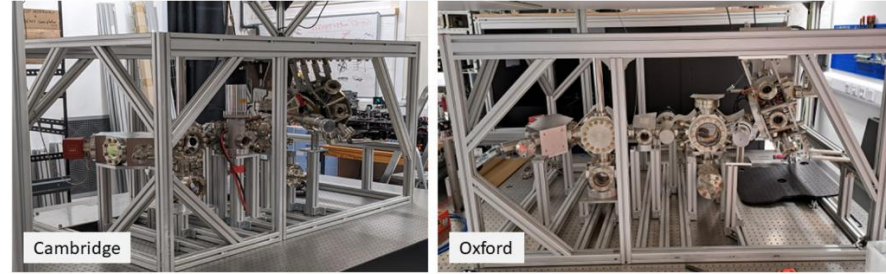

- 5 similar systems
- Independent development of specific areas
- Exchange of knowledge between systems

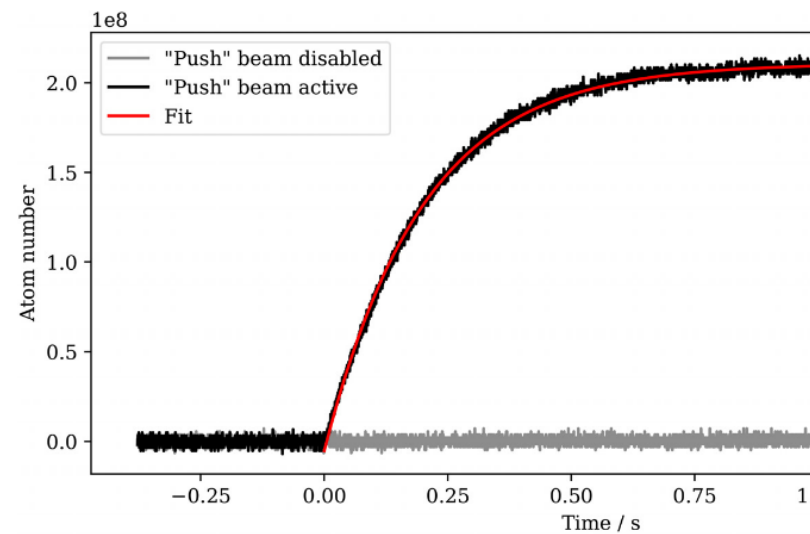

Stray et al., AVS Quantum Sci. 6, 014409 (2024)  
E. Pasatembou et al., AVS Quantum Sci. 6, 014408 (2024)

# Motivation – device sensitivity

$$\text{Sensitivity} \sim \left(\frac{1}{T}\right)^{\frac{5}{4}} \frac{1}{Cn\Delta r} \left(\frac{\Delta t}{N_{atom}}\right)^{\frac{1}{2}} \left(\frac{1}{T_{int}}\right)^{\frac{1}{4}}$$

|            |  |
|------------|--|
| $T$        | Interferometer duration                          |
| $C$        | Contrast   |
| $n$        | Number of LMT                                    |
| $\Delta r$ | Separation between interferometers               |
| $\Delta t$ | Time between successive interferometer sequences |
| $N_{atom}$ | Number of atoms                                  |
| $T_{int}$  | Total integration time                           |

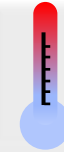

Colder atoms

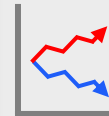

Large momentum transfer



Reliability



More atoms

# Experimental sequence: Sr

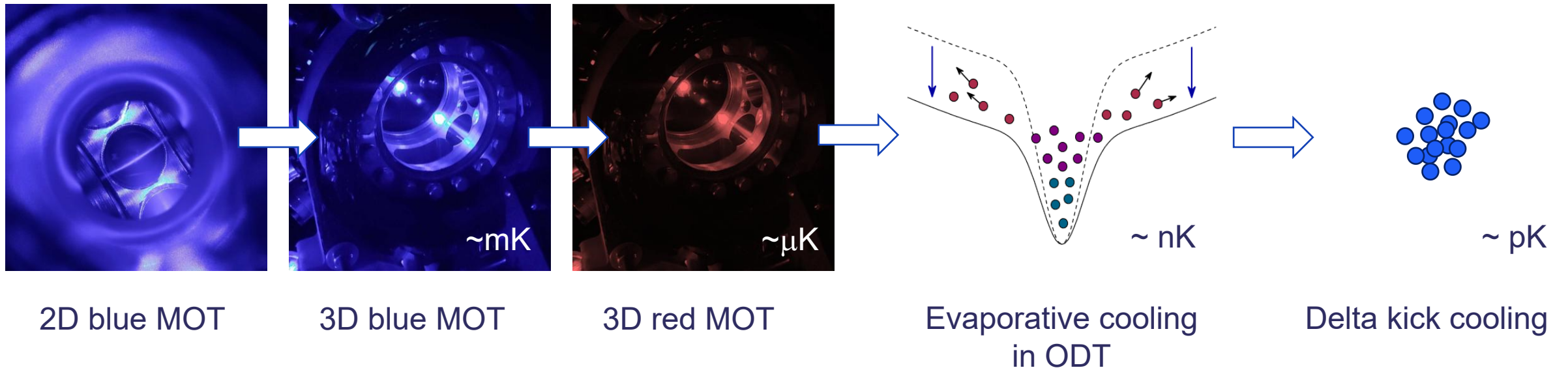

# Existing source examples

High flux

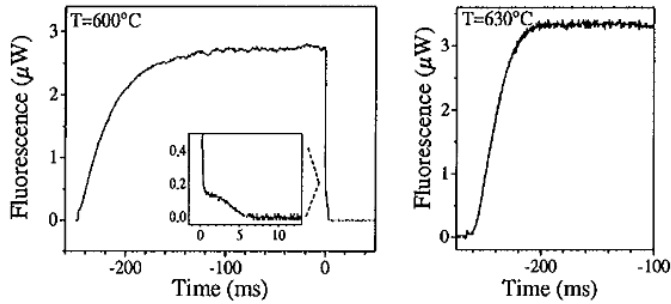

Courtillot et al., *Optics Letters* Vol. 28, Issue 6, pp. 468-470 (2003)

Commercial system

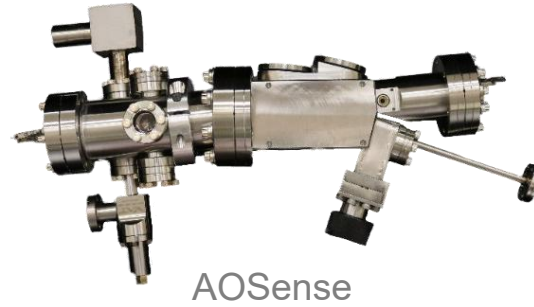

AOSense

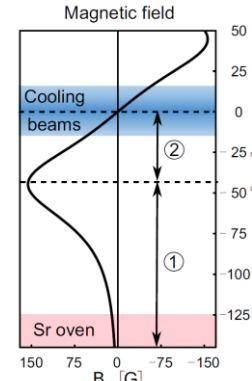

No additional ZS magnets

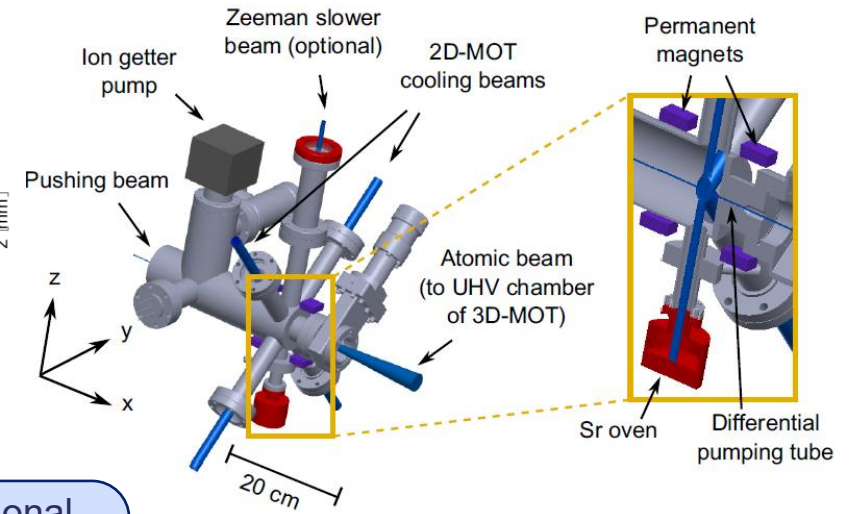

Nosske et al., *Phys. Rev. A* 96, 053415 (2017)

Compact source

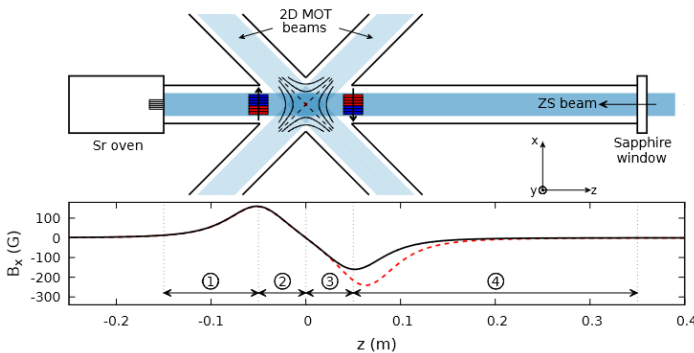

C-H Feng et al *Quantum Sci. Technol.* 9 025017 (2024)

Boughdachi et al., arXiv:2507.23617 (2025)

Quasi-continuous

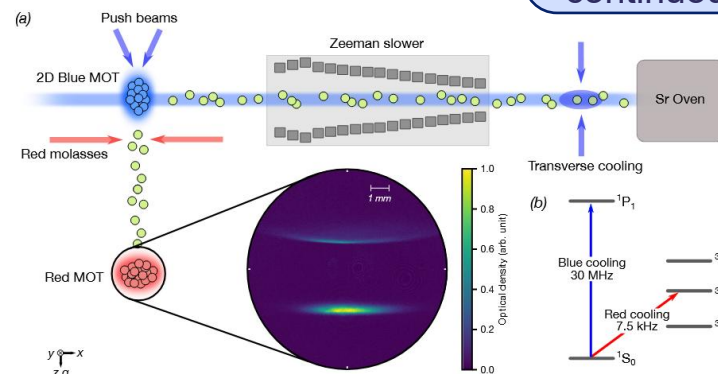

2D MOT deflector

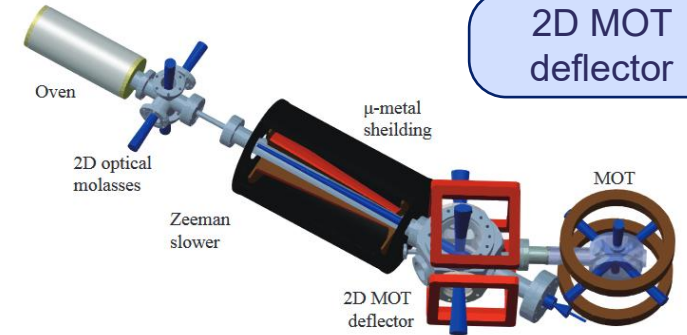

Yang et al., *Eur. Phys. J. D* 69, 226 (2015)

# Chamber design

Oven • Zeeman slower • 2D MOT • Push beam

Foot group

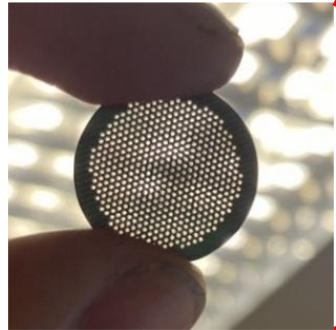

RAL Space

0.3mm diameter  
3mm long

Oven output collimated  
by steel nozzle

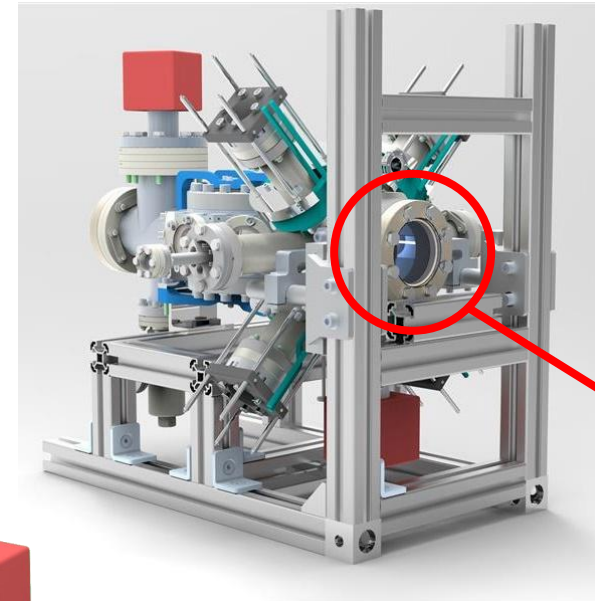
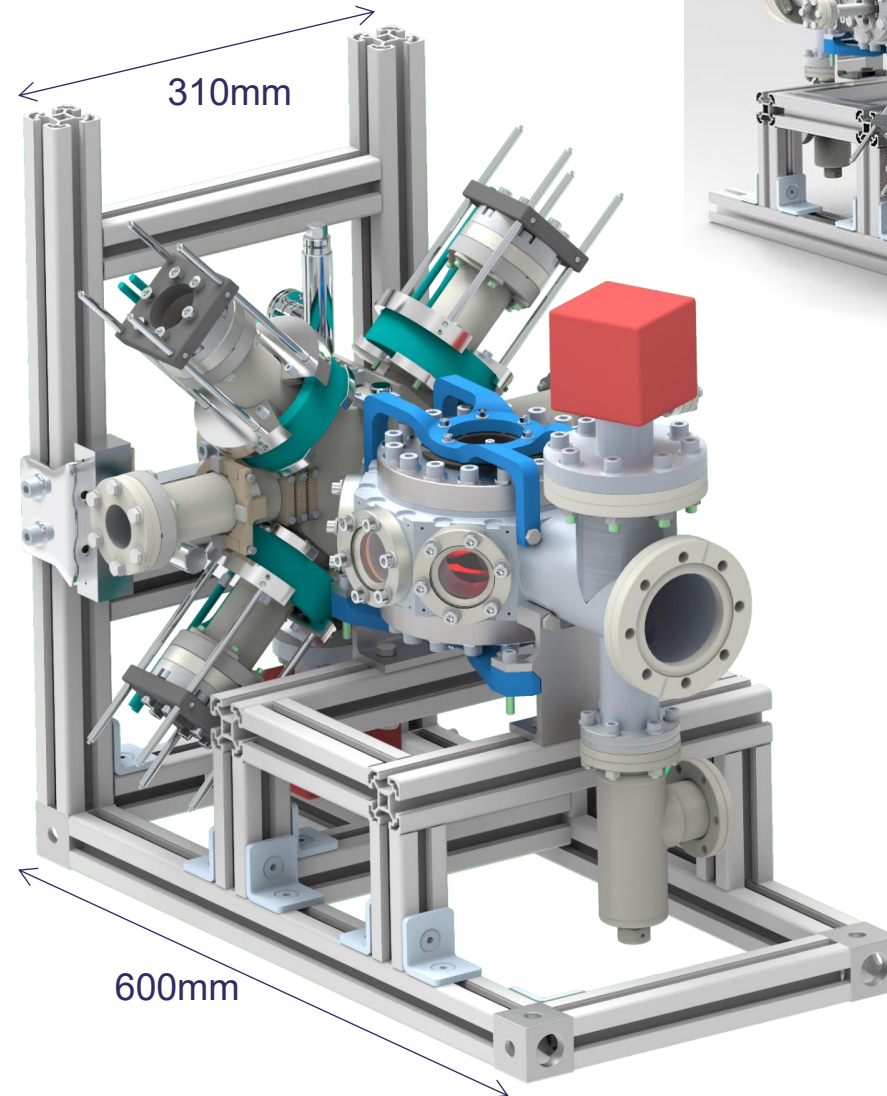
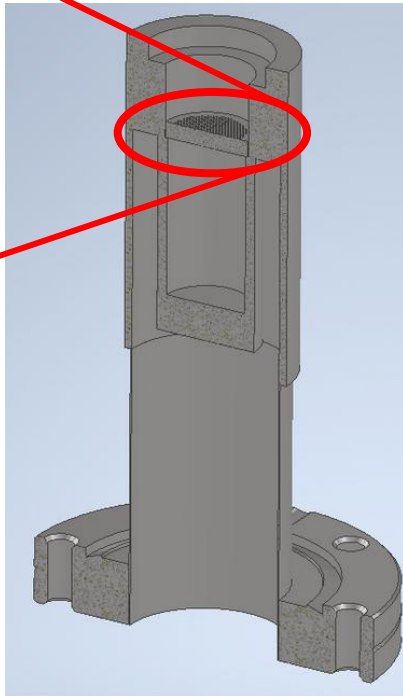

Good optical  
access for push  
beam/ diagnostics

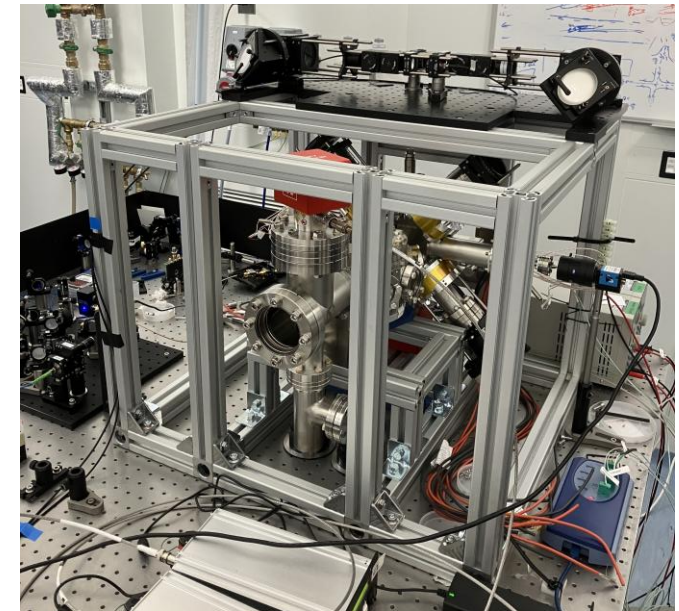
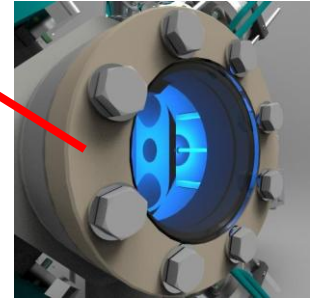

# Chamber design

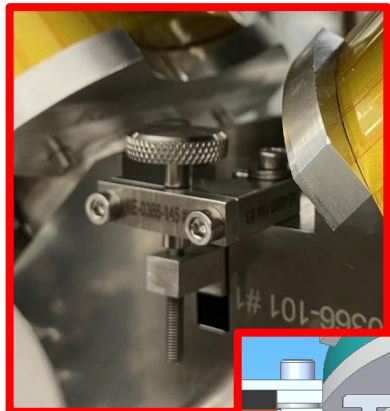

Adjustable magnet positioning

$\Delta = 1\text{G/cm/mm}$

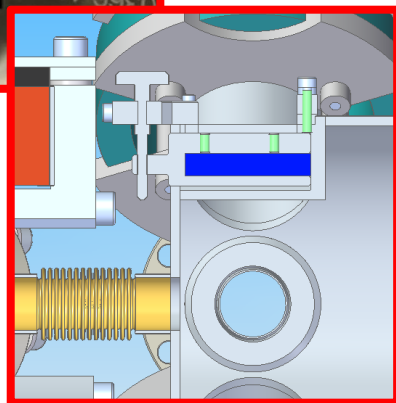

2D MOT field

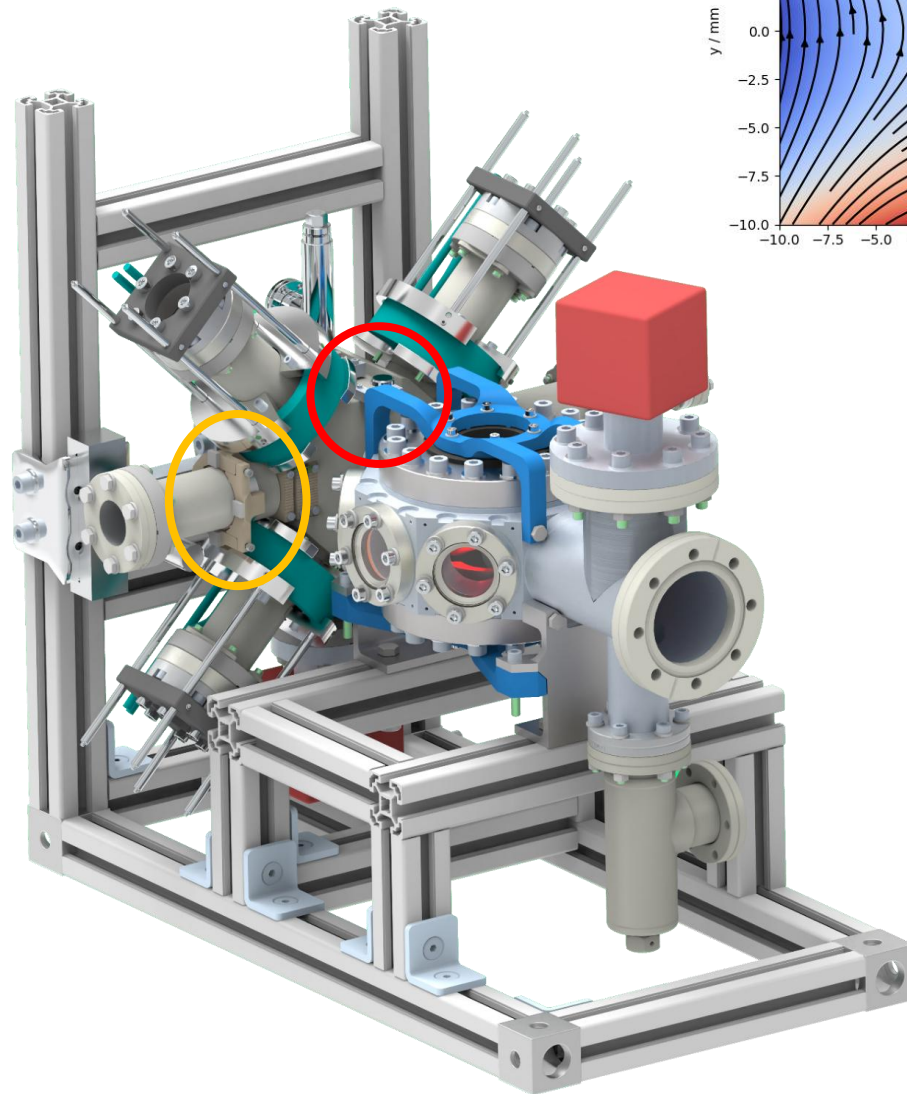
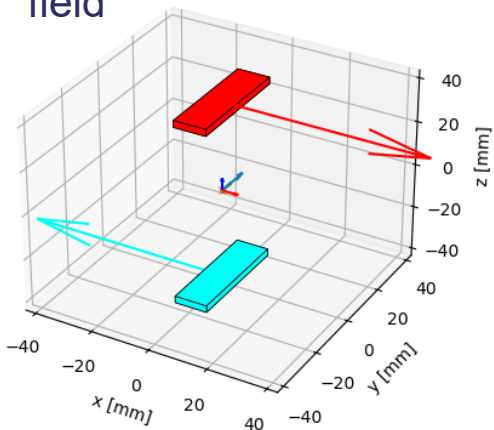

2D MOT field gradient

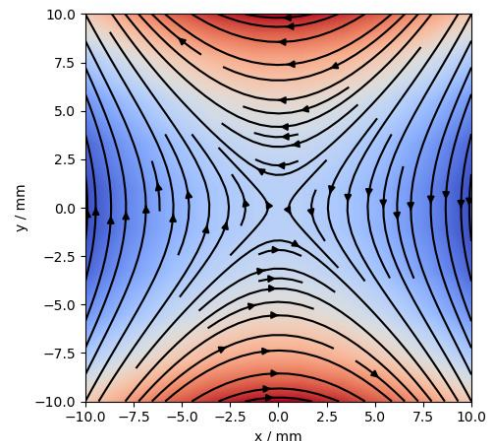

Zeeman field supplemented with additional, adjustable magnets

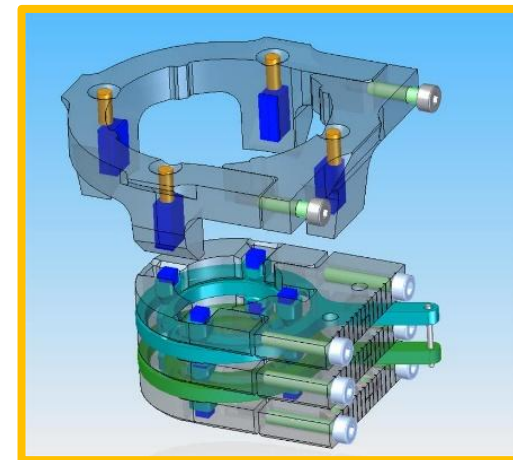

Zeeman slowing field

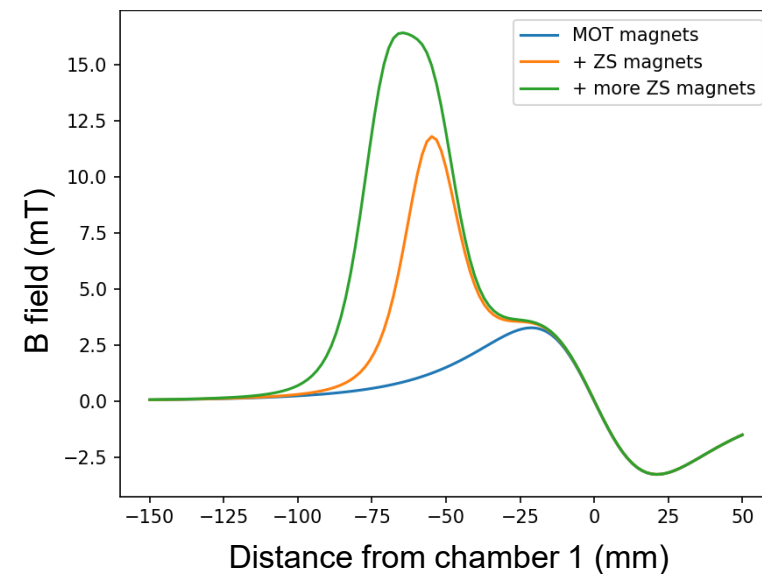

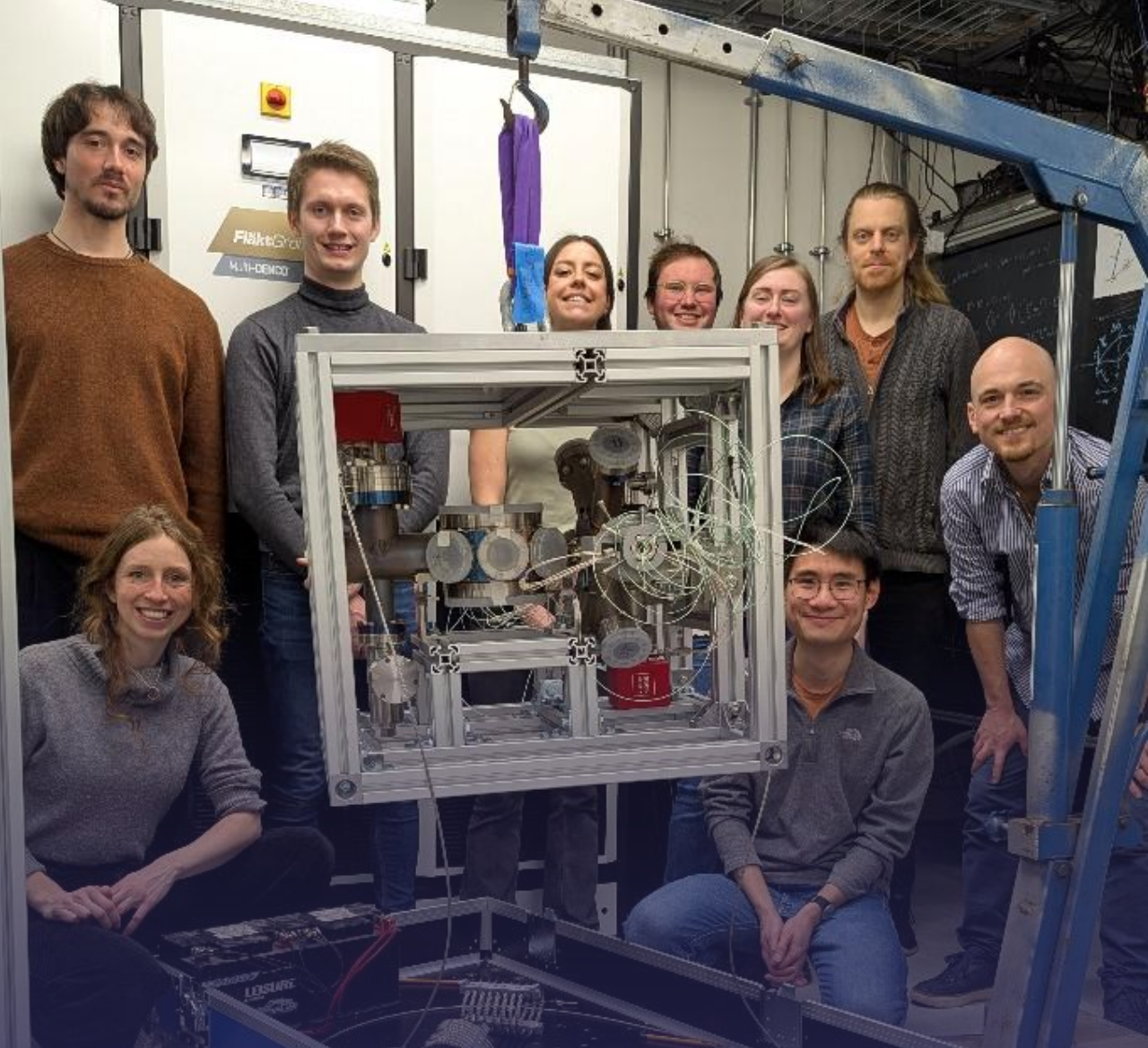

Science and  
Technology  
Facilities Council

RAL Space

**IMPERIAL**

# Oven spectroscopy

Transverse spectroscopy along push beam direction

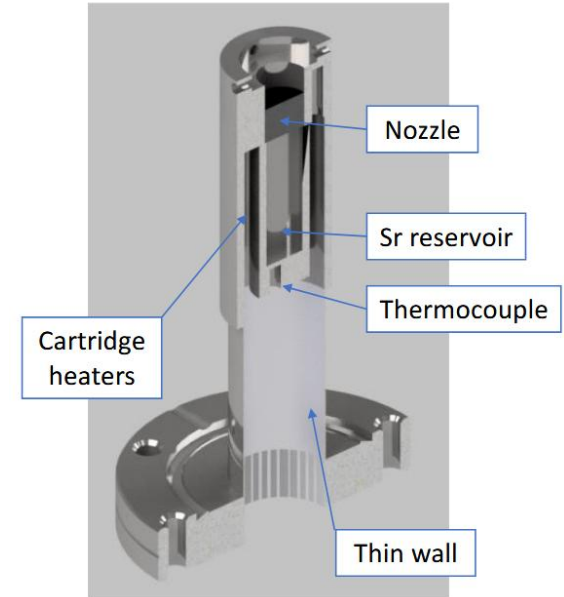
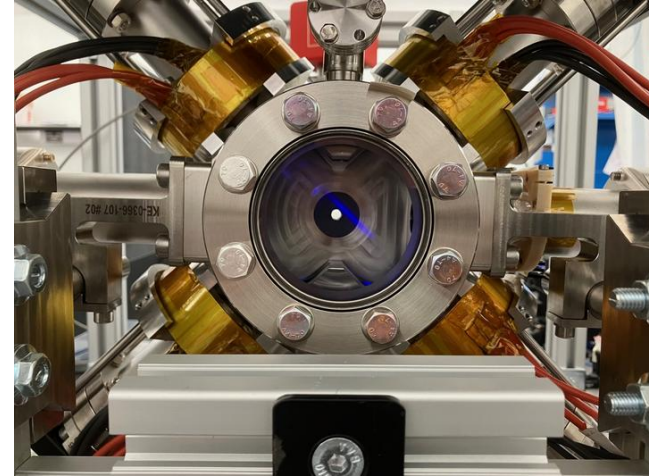
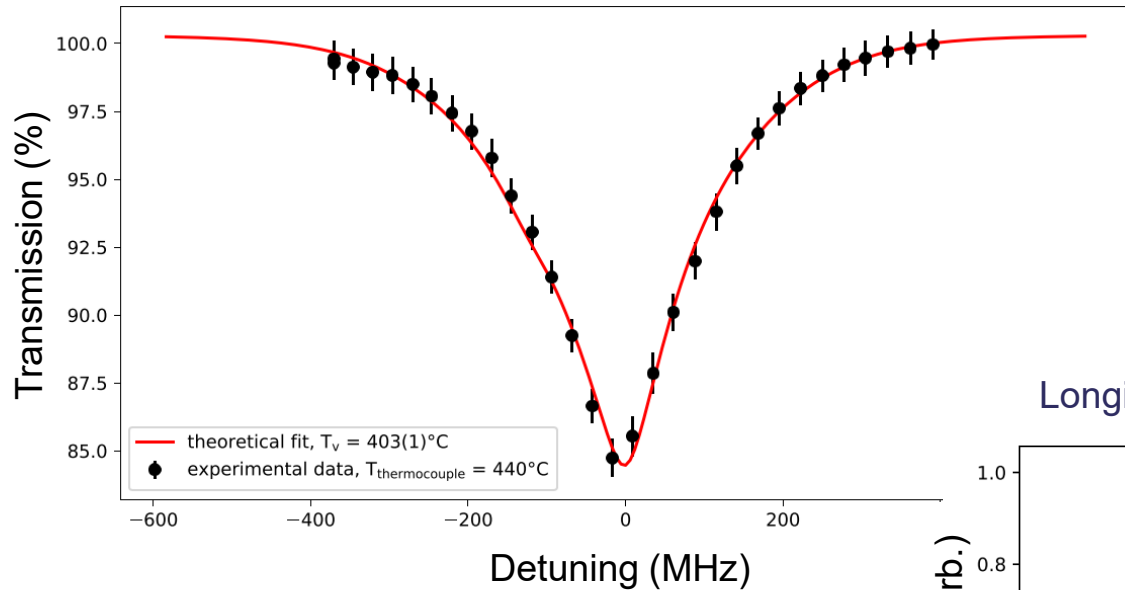

Oxford oven design

Longitudinal spectroscopy across 2D MOT axis

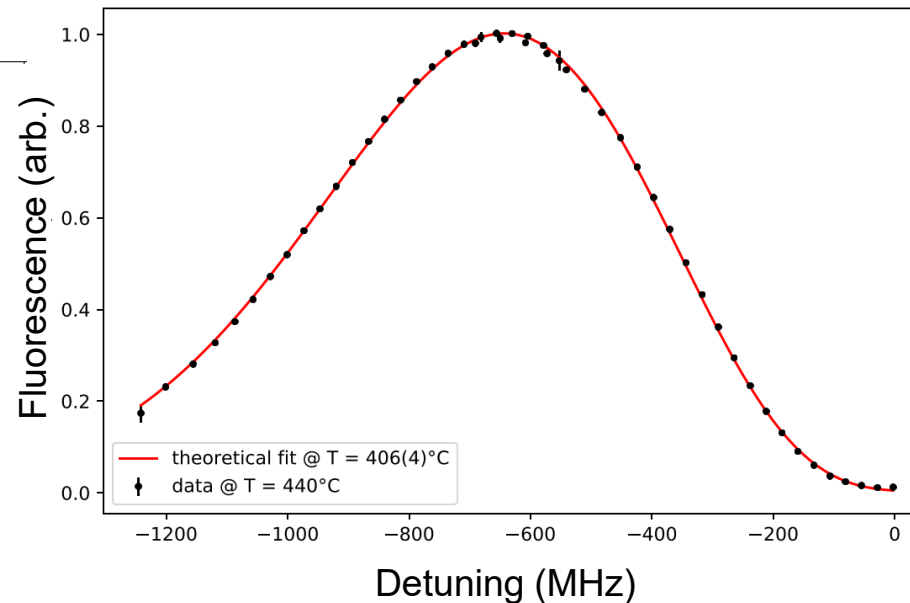

Agreement between thermocouples and modelling to within  $\sim 10\%$

# 2D MOT flux

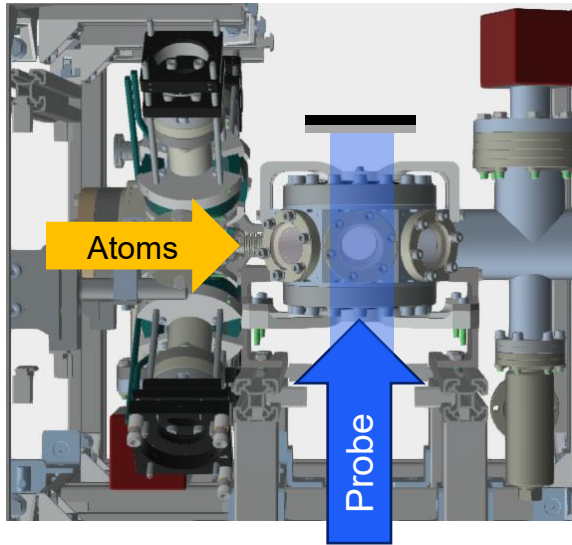

- Probe transverse velocity profile at 3D MOT position
- Probe beam retro-reflected

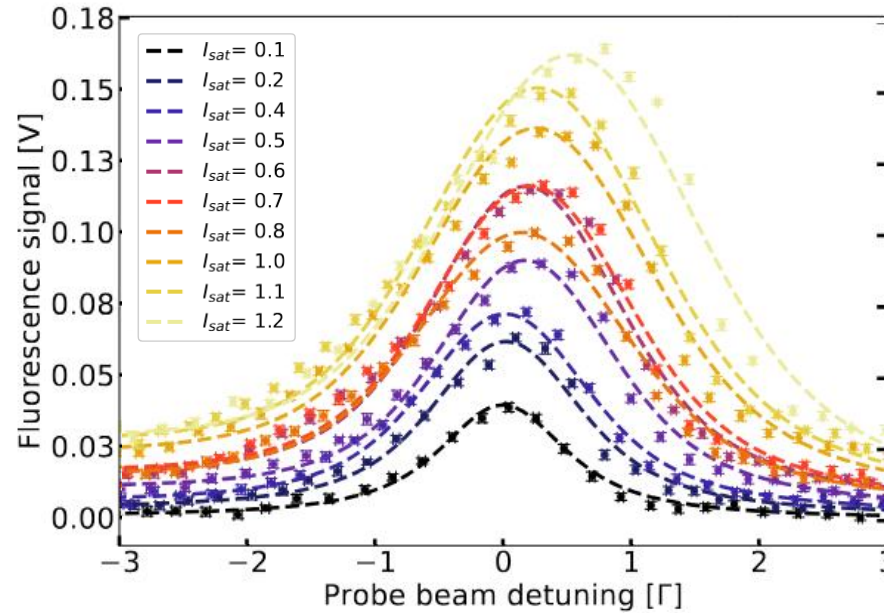

Blue shifting of signal for increasing probe intensity  
→ Atoms pushed away

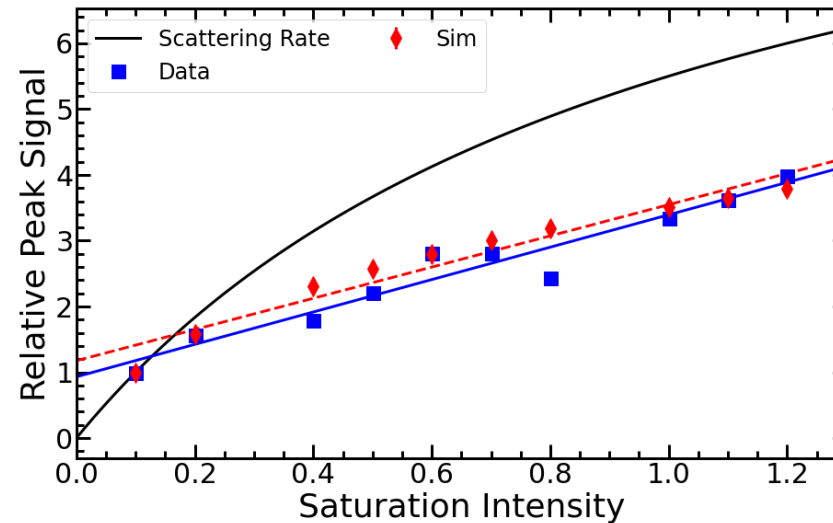

Deviation of scattering rate from expected value

- Loss from field of view
- Doppler shifting

# 2D MOT flux

→ Maximise useable flux for 3D MOT

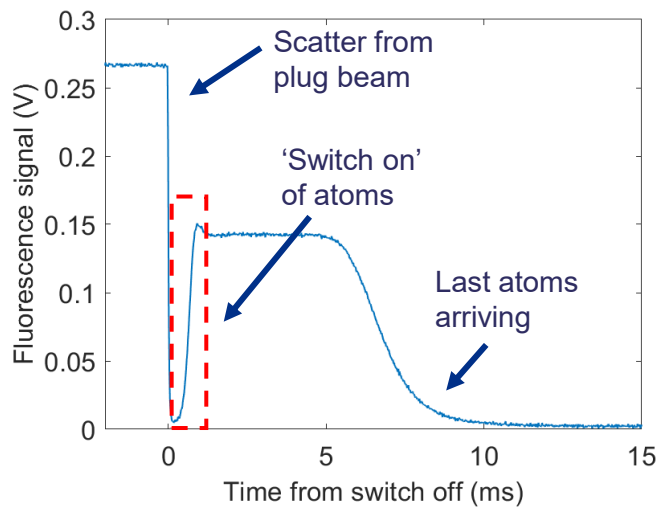
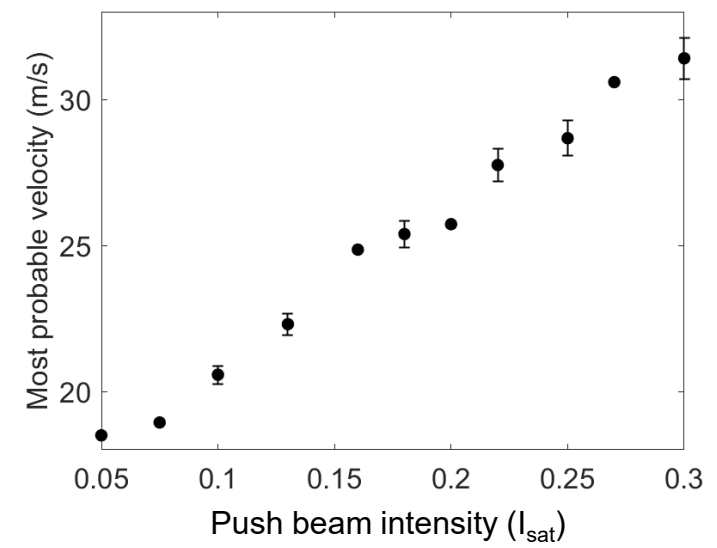
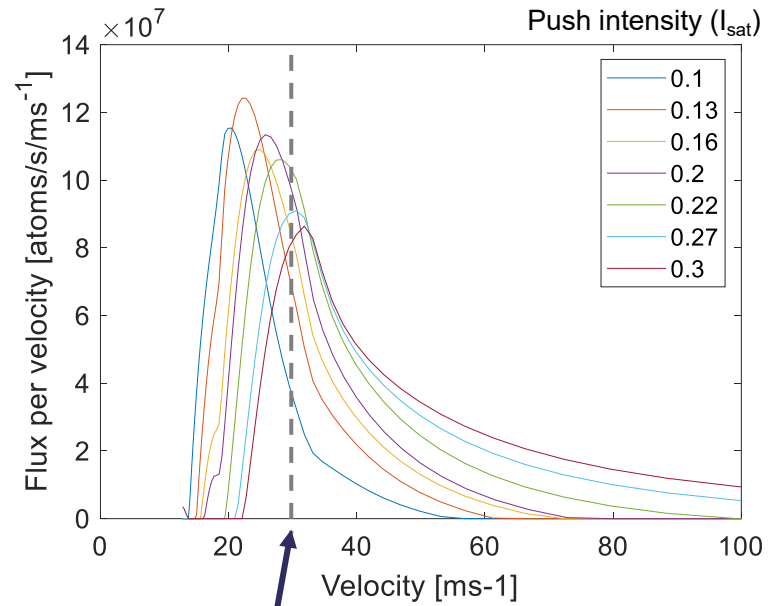
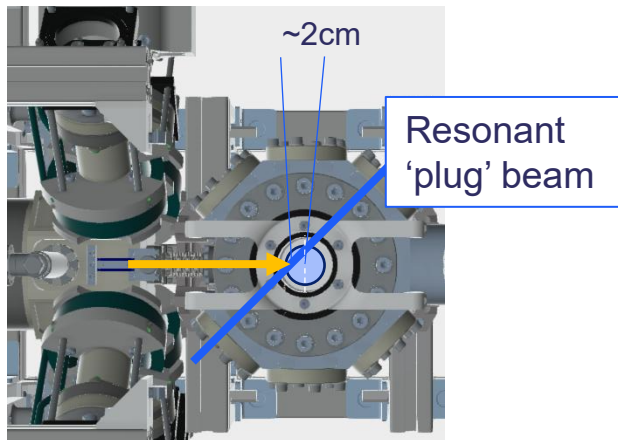

$$v_{cap} (max) = \sqrt{2 \frac{\hbar k \Gamma}{2m} D}$$

3D MOT capture velocity

~ 30m/s for a typical Sr 3D MOT setup

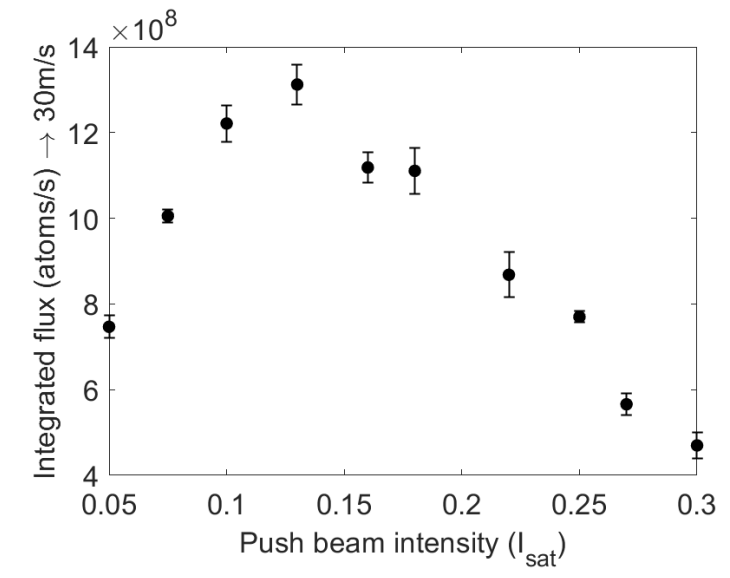

# 3D MOT loading

Ultimate metric is the loading rate of the 3D MOT

- Compact chamber design
  - Oven close to 2D MOT
  - 2D MOT close to 3D MOT
- Sideband added to 2D MOT beams
- Repump added to 2D MOT (~30% gain)

Initial loading rate:  $\sim 4 \times 10^{10}$  atoms/s

- Operating typically at  $\sim 410^\circ\text{C}$
- Increased source lifetime
- Less experimental downtime for refilling

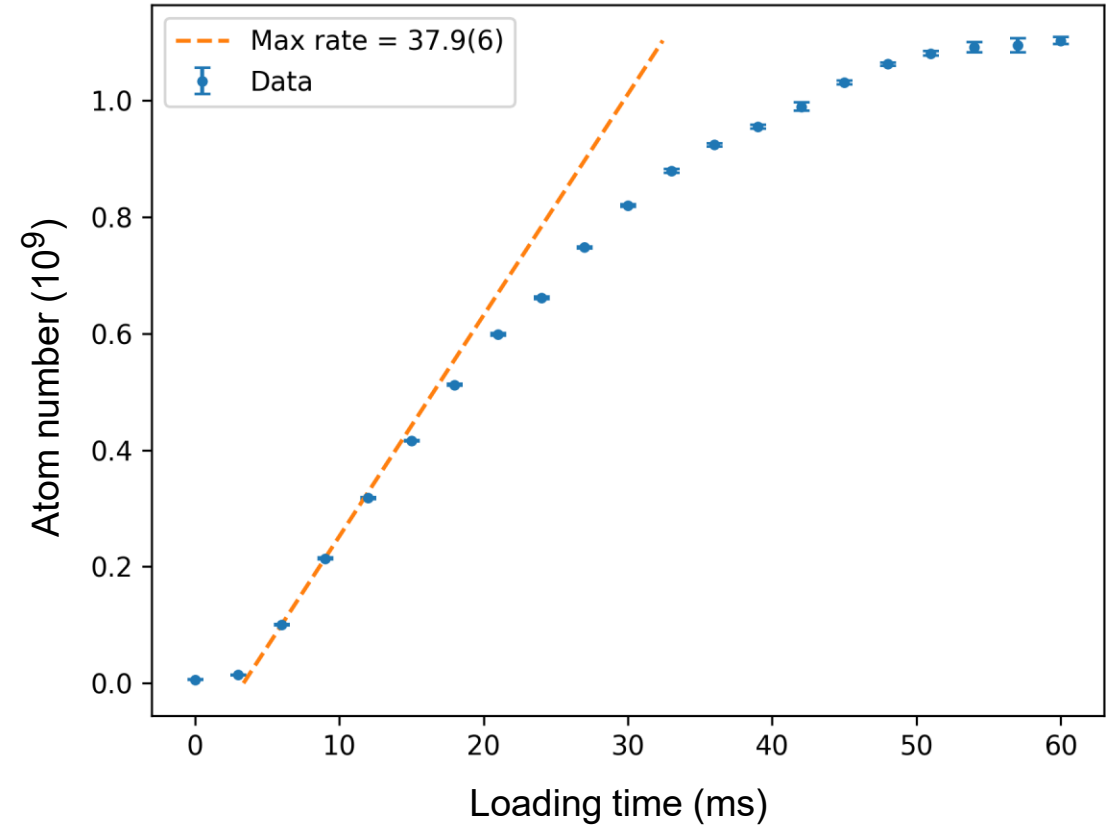

Comparable flux to highest literature values  
but operating at **much lower  $T$**   $\rightarrow$  longer  
lifetime

Courtillot et al., Optics Letters Vol. 28, Issue 6,  
pp. 468-470 (2003)

# Outlook

# IMPERIAL

## Continuous source

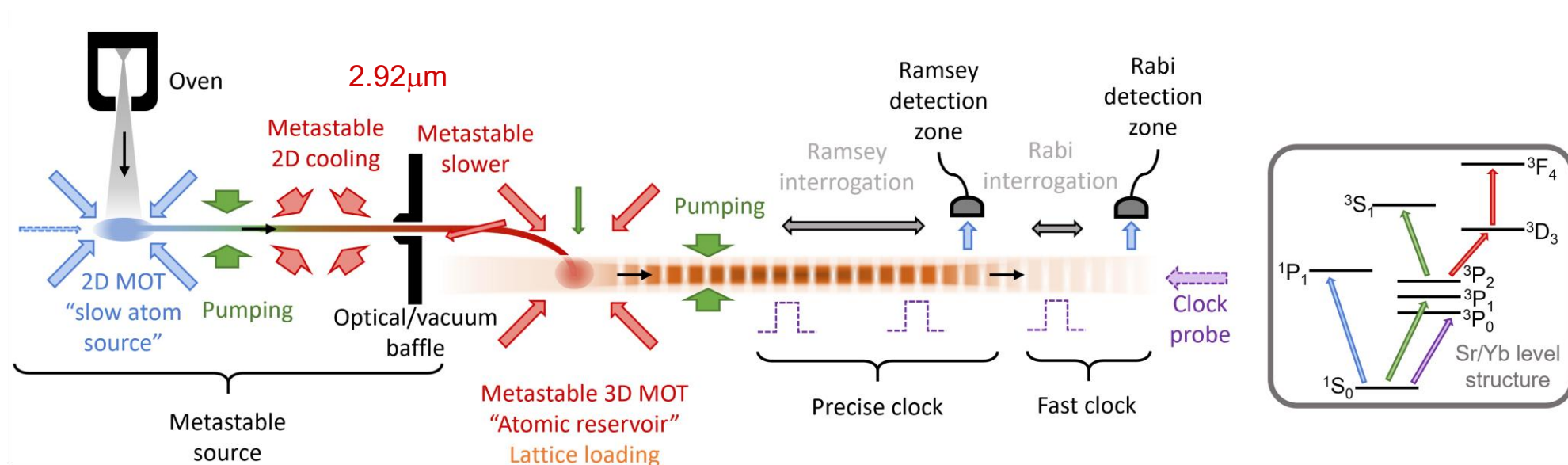

**Goal:** Continuous source for high repetition rate, interleaved AI, clocks...

# Towards a metastable source

# IMPERIAL

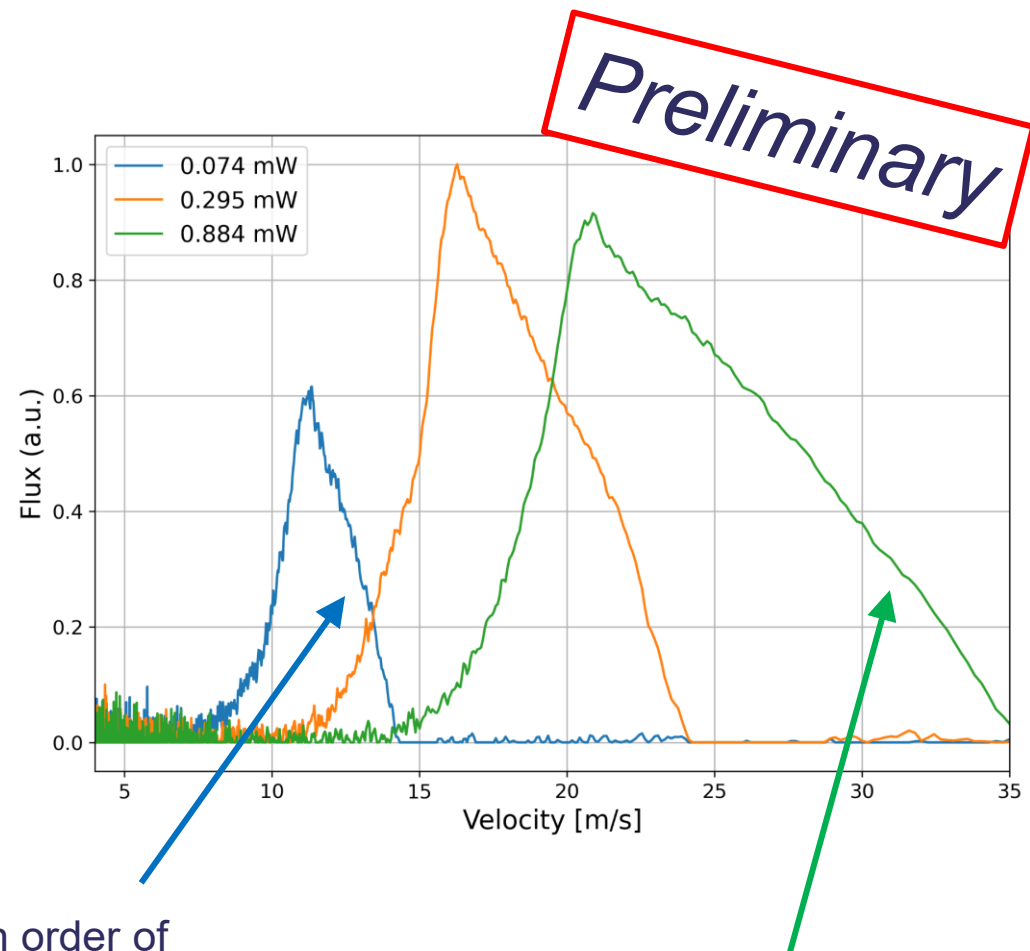
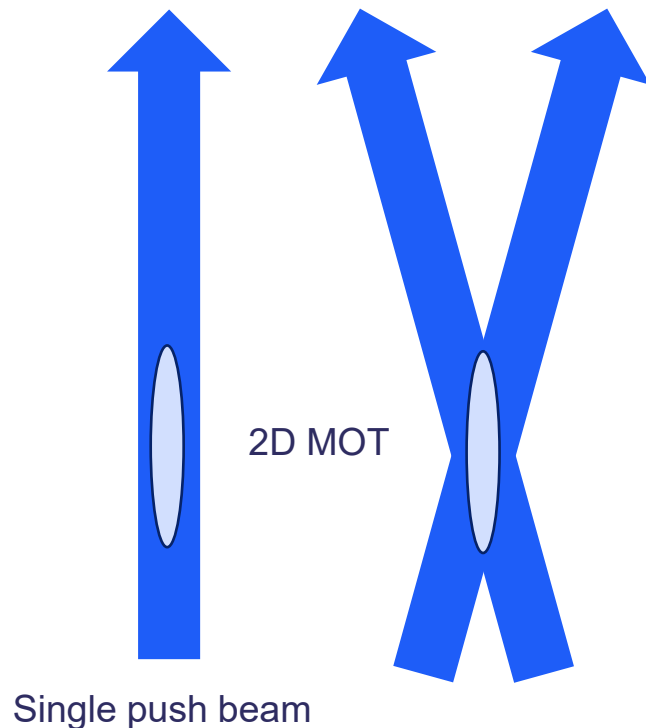
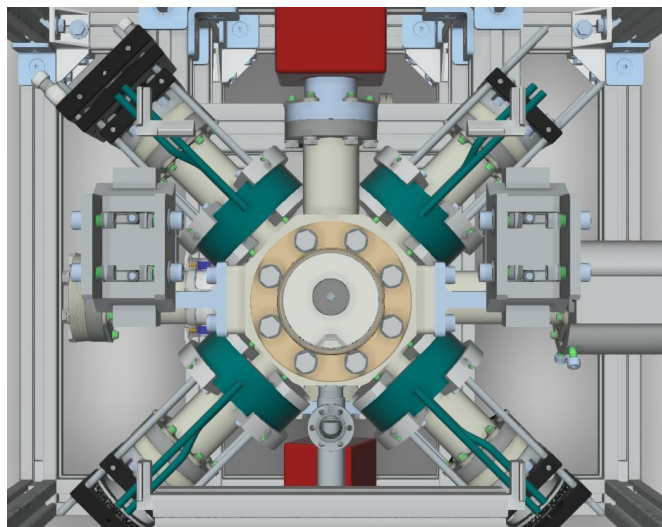

Less than an order of magnitude reduction in flux but possibility to reach ~ 10m/s

Comparable 3D loading rate to single beam case

**STFC:**  
**RAL Space**  
**Particle Physics**  
**Daresbury Laboratory**

Hamza Labiad  
Tim Thornton  
Mark Bason  
Kamran Hussain  
Katy Clarke  
Andrew Vick  
Maurits van der Grinten  
Tristan Valenzuela

**Imperial**

Tom Walker  
Leonie Hawkins  
Ludovico Iannizzotto Venezze  
Charles Baynham  
Richard Hobson  
Oliver Buchmueller

**Oxford**

Kenneth Hughes  
Chris Foot

**Thank you**

