



LINAC 4 - DTL - Drift tube Assembly procedure

**Mini Workshop on DTL Design
13.09.2011**

**Y. Cuvet, A. Dallocchio, S. Ramberger, M. Vretenar,
T. Tardy, G. Favre, F. Carra, I. Sexton, J.M. Geisser, J.M. Giguët**

This document describes the assembly stages of a drift tube.

Description of DT assembly stages:

- Complements drawings**
- Describes the order of fabrication**
- Makes sure that no stage is forgotten**

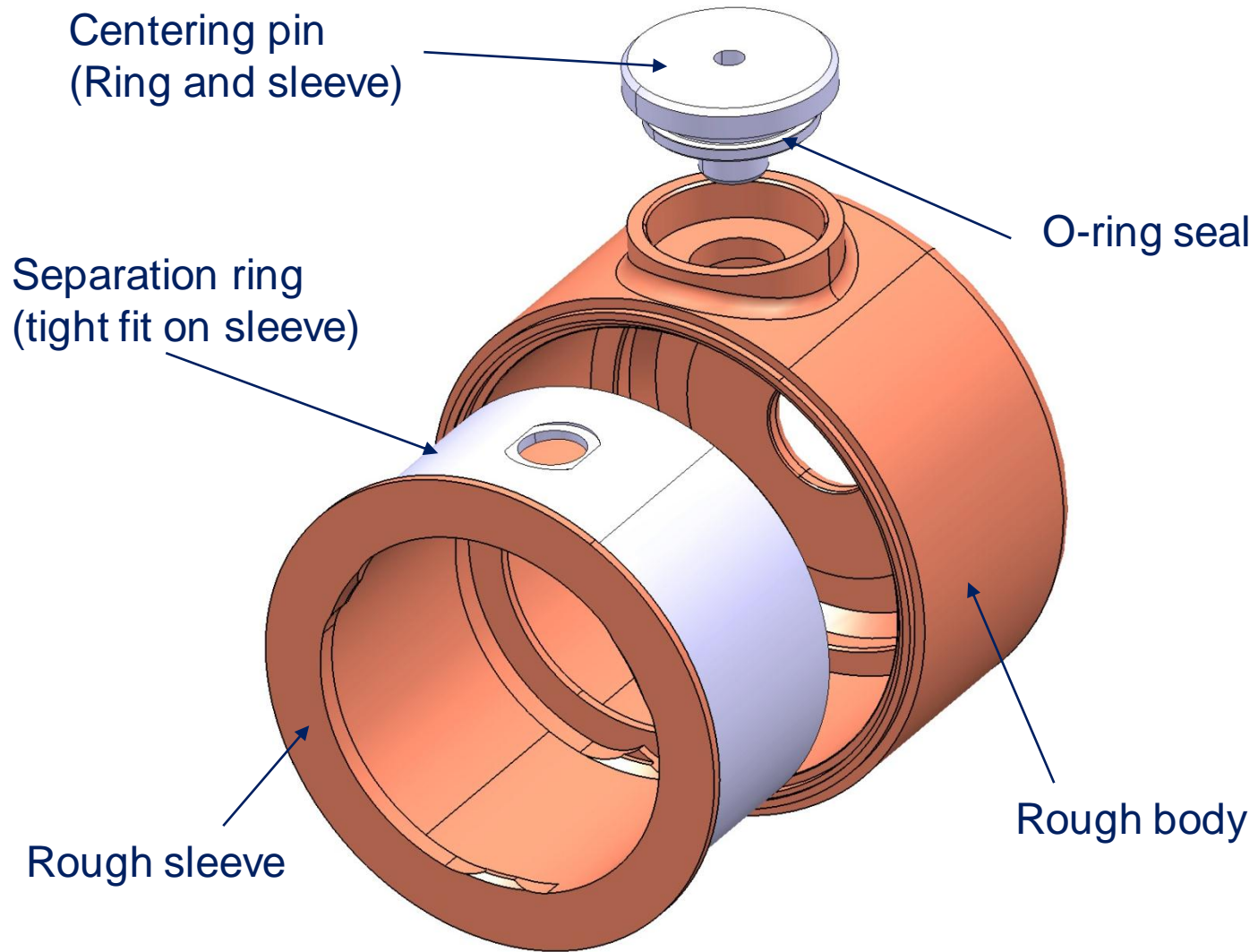

EB WELDING 1 & 2

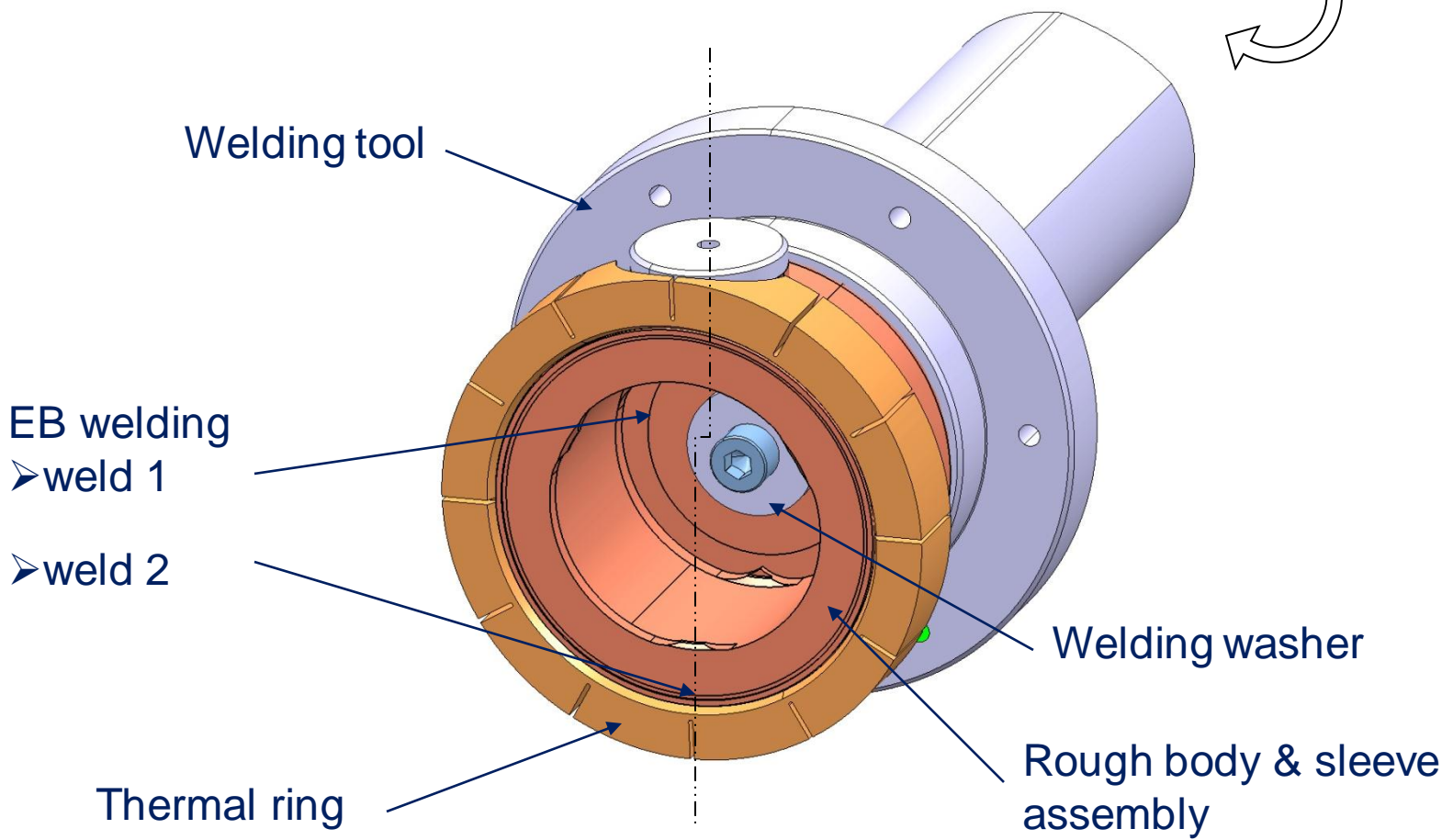

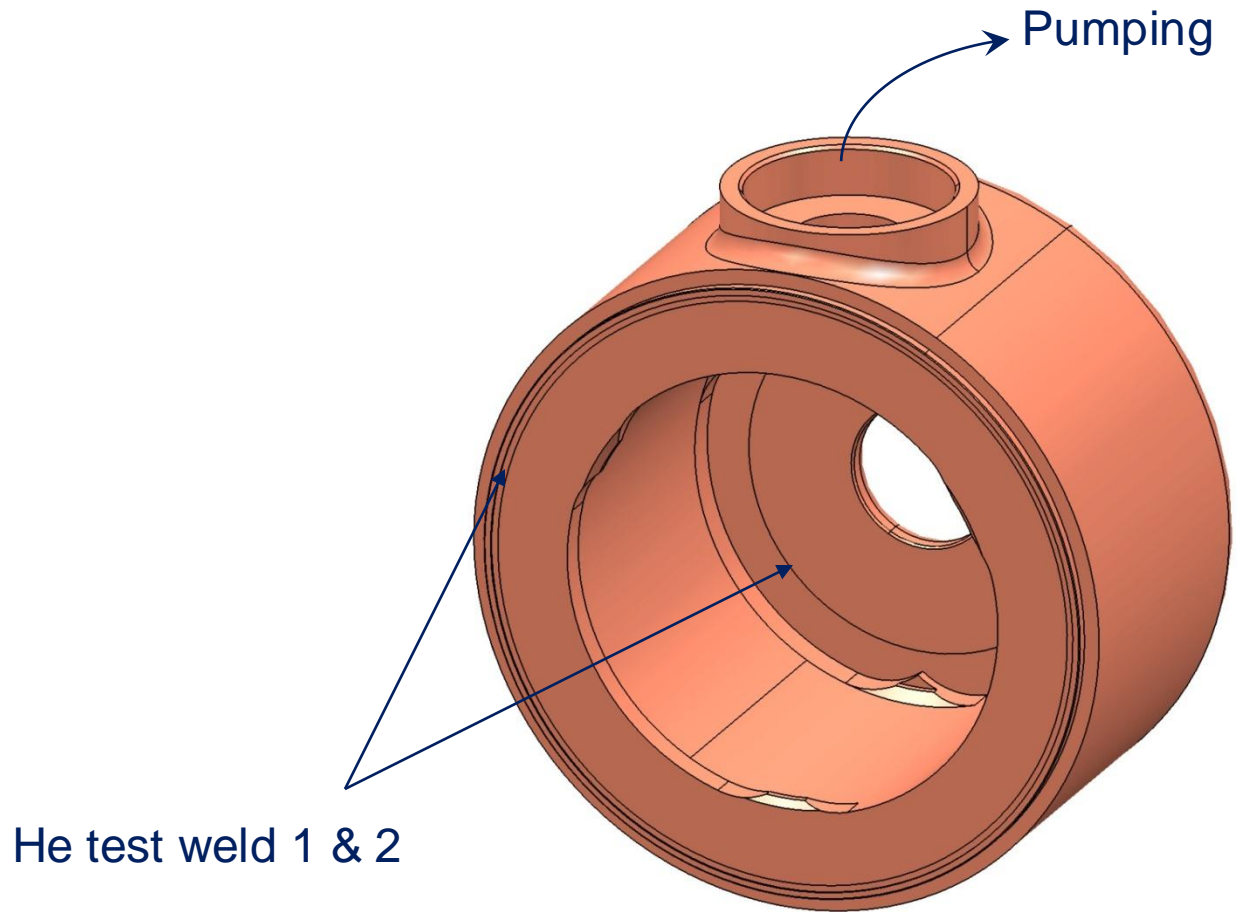

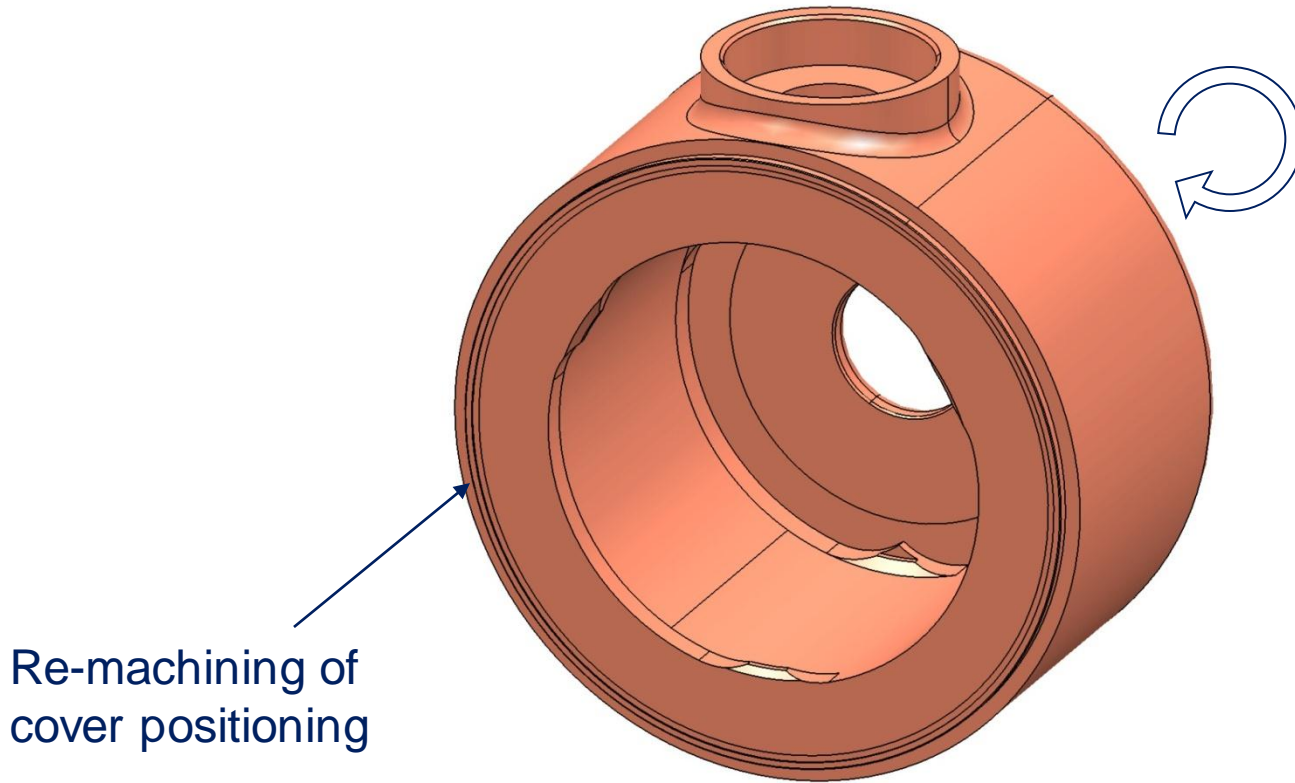

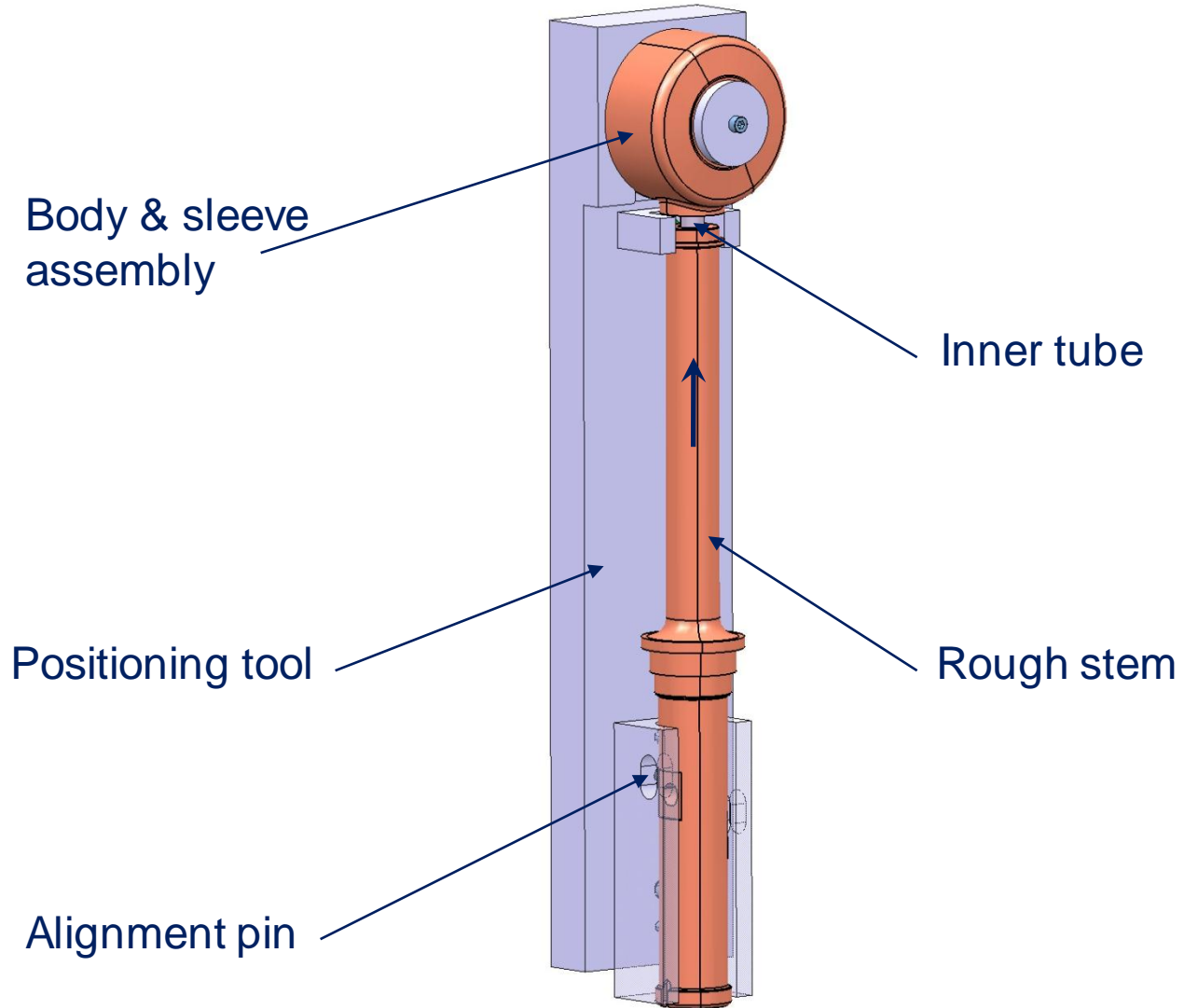

EB WELDING 3

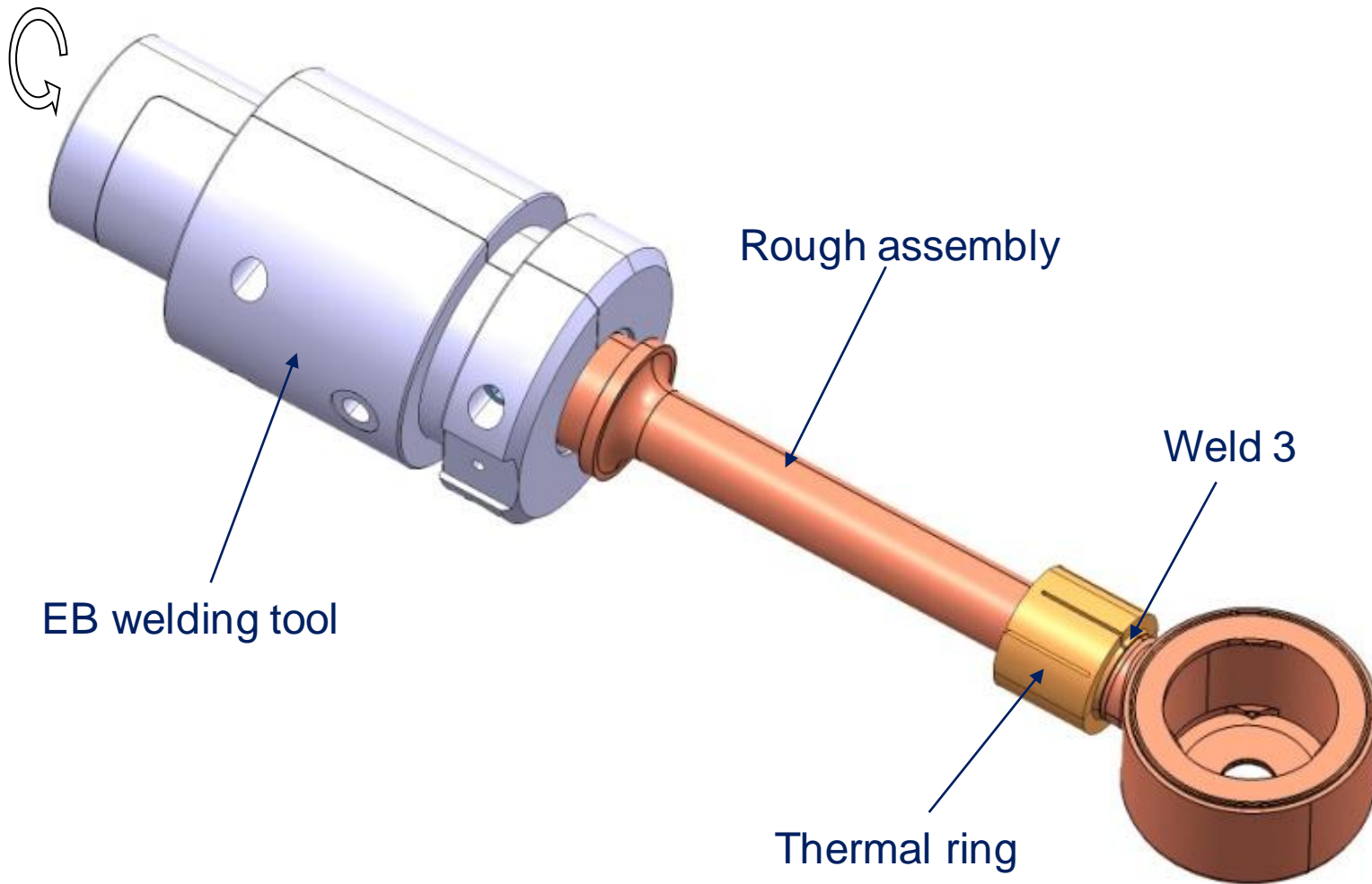

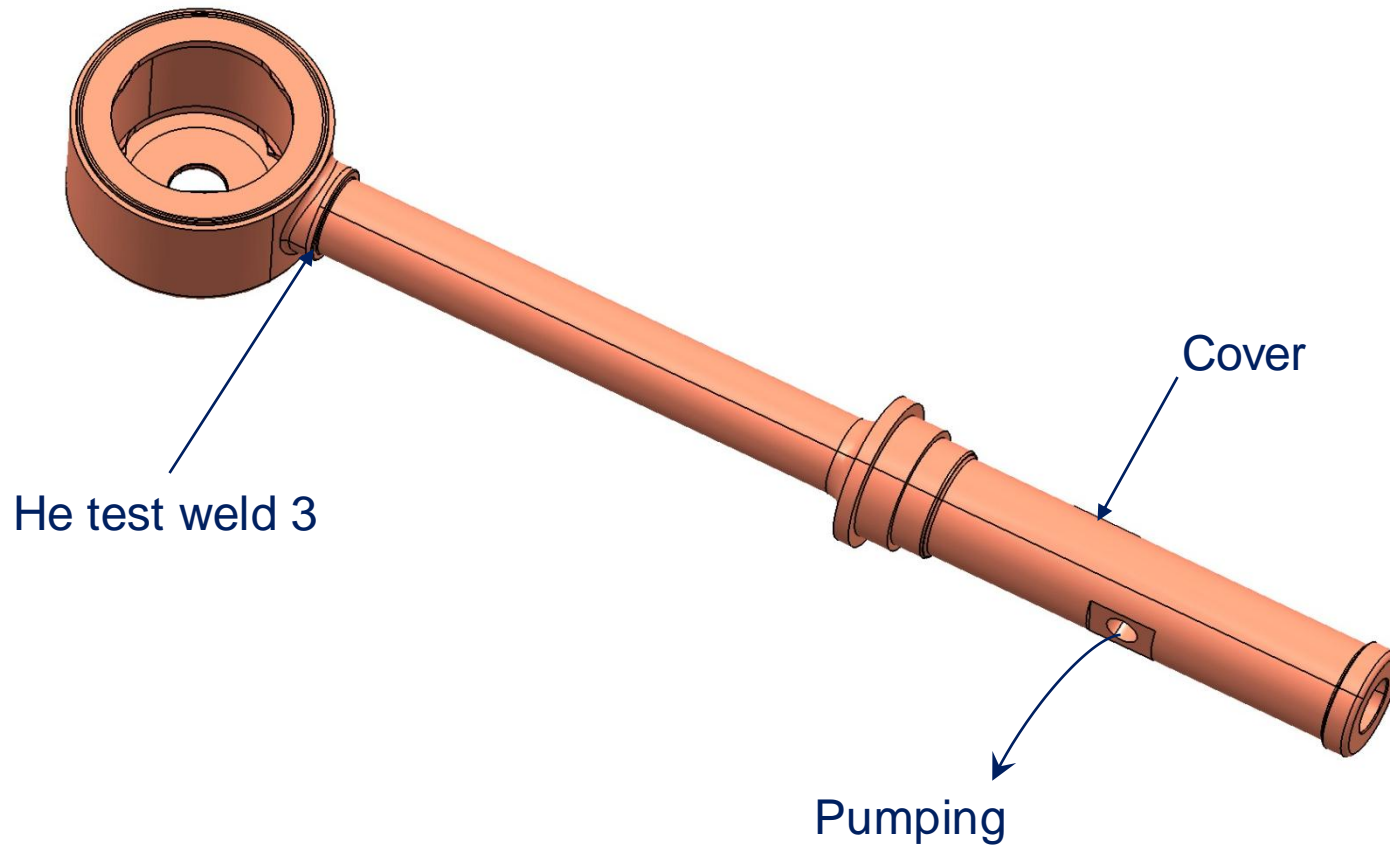

RE-MACHINING

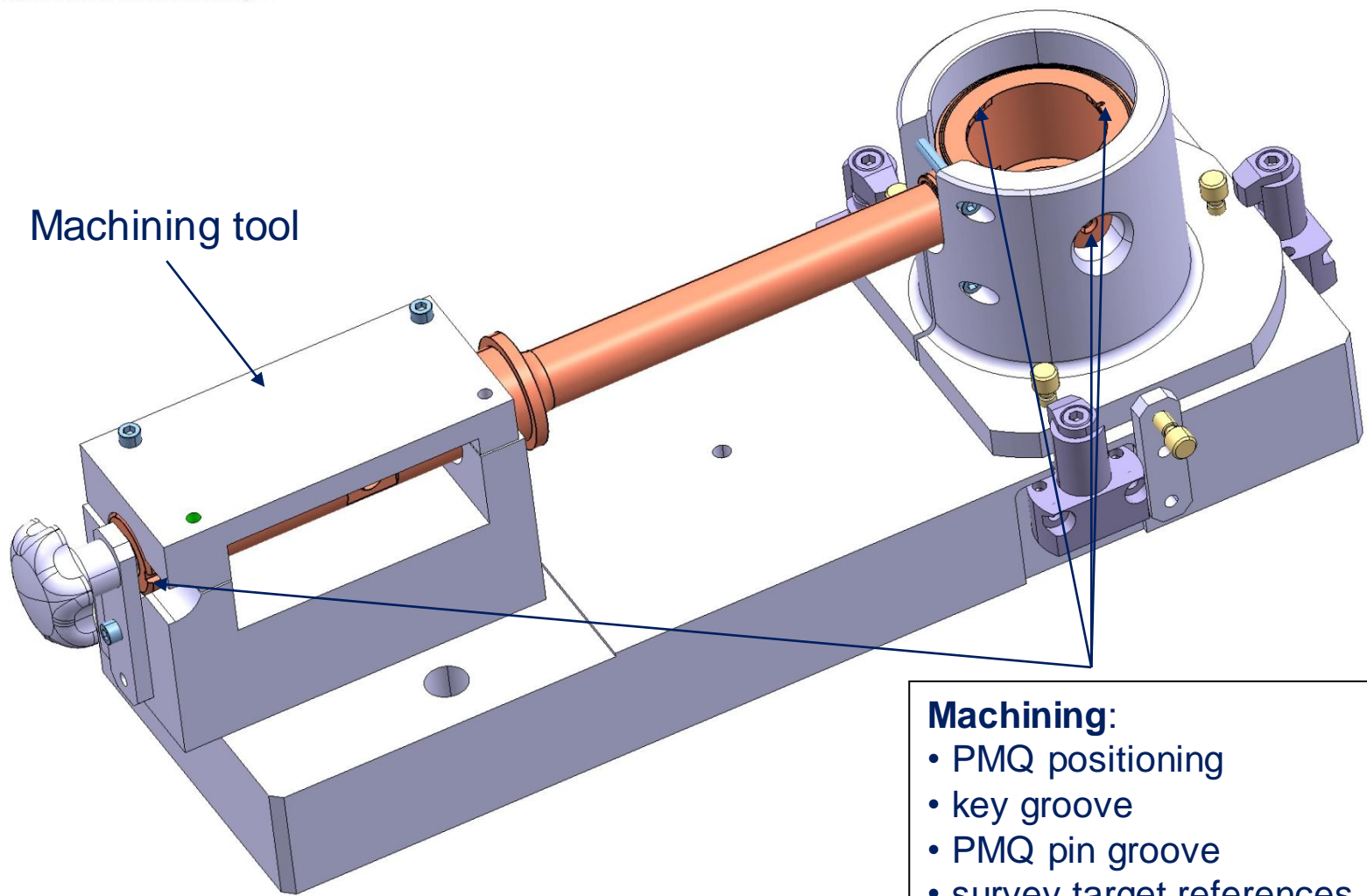

Machining tool

- Machining:**
- PMQ positioning
 - key groove
 - PMQ pin groove
 - survey target references

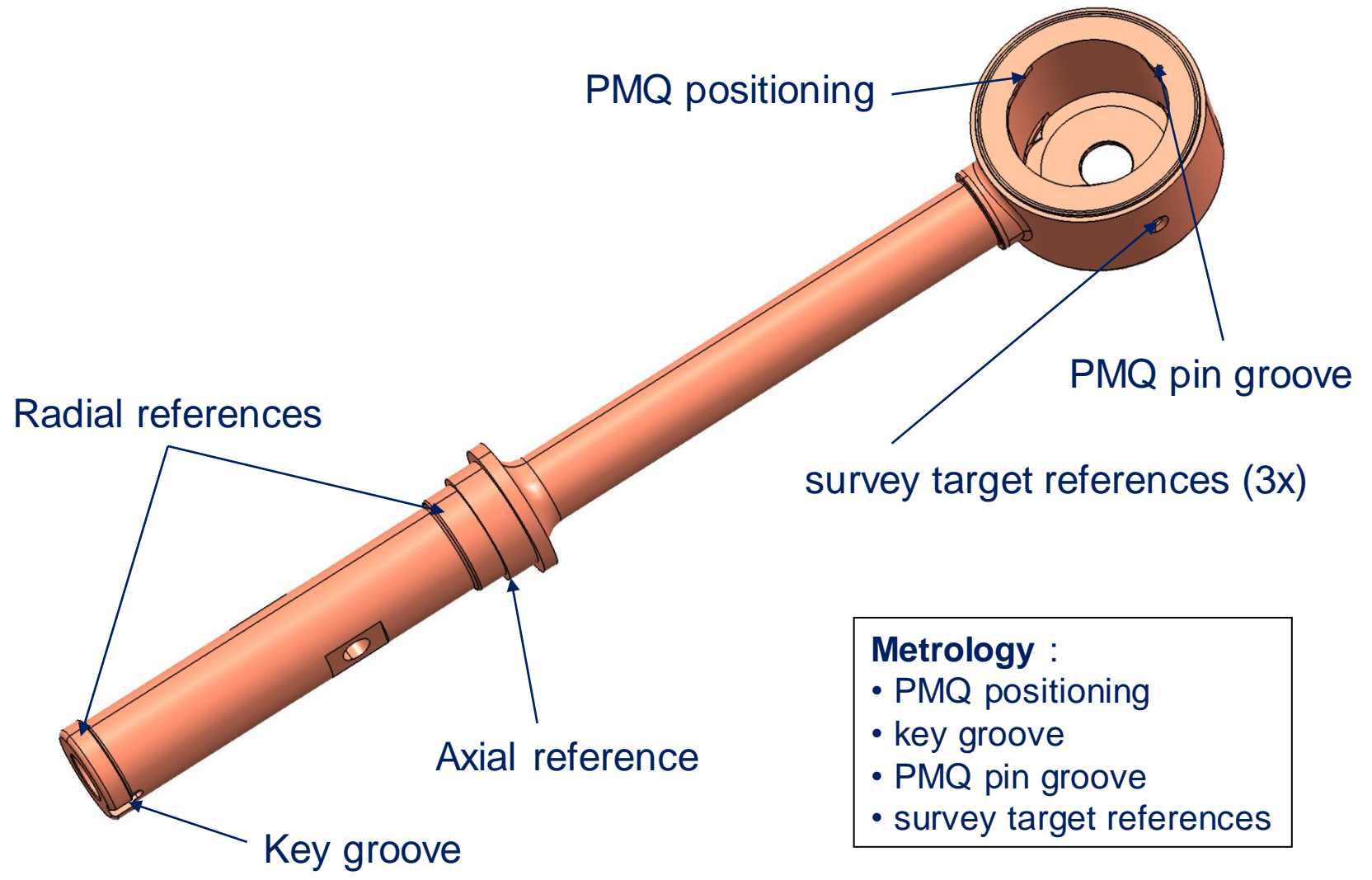

- Metrology :**
- PMQ positioning
 - key groove
 - PMQ pin groove
 - survey target references

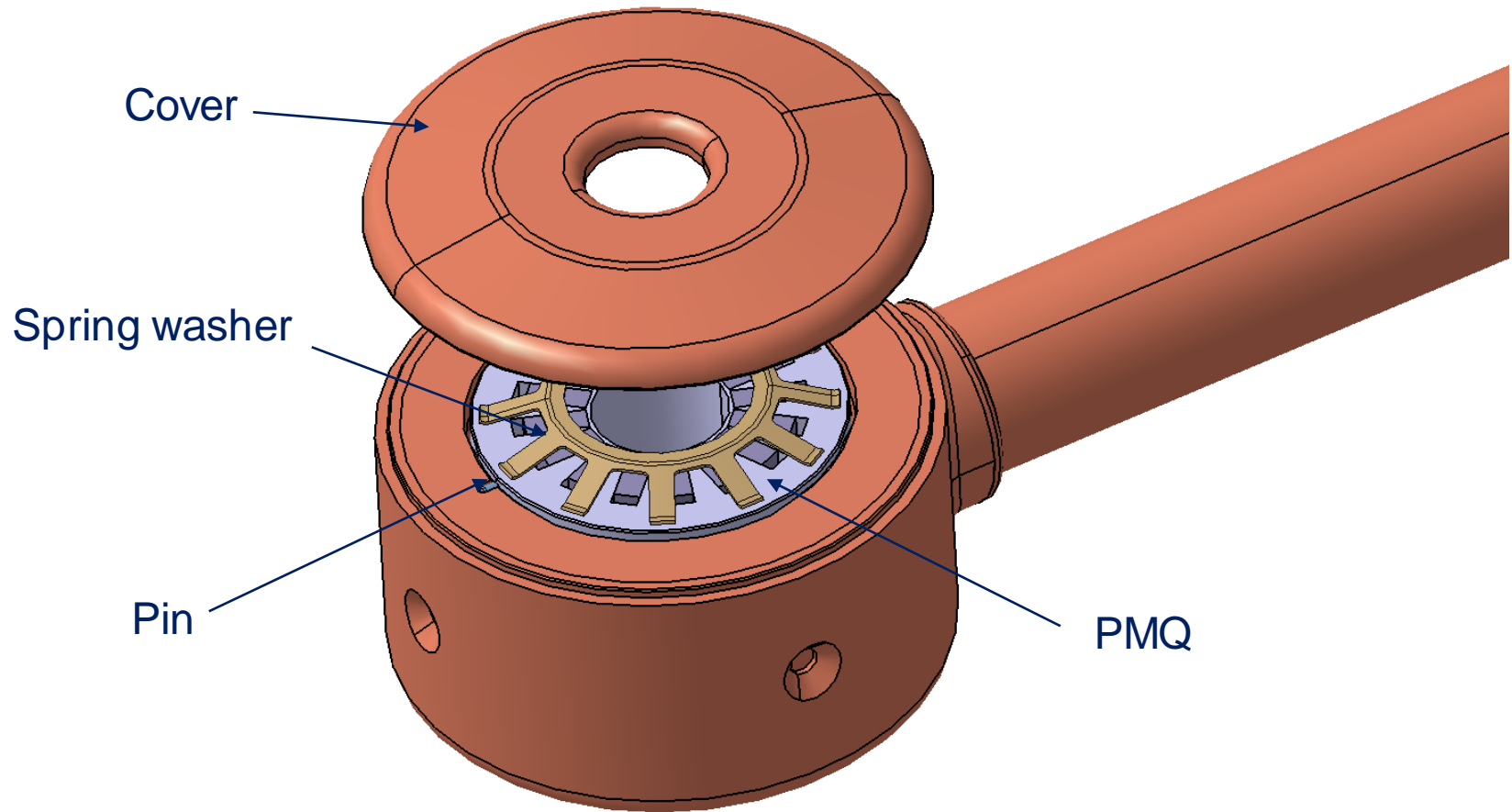

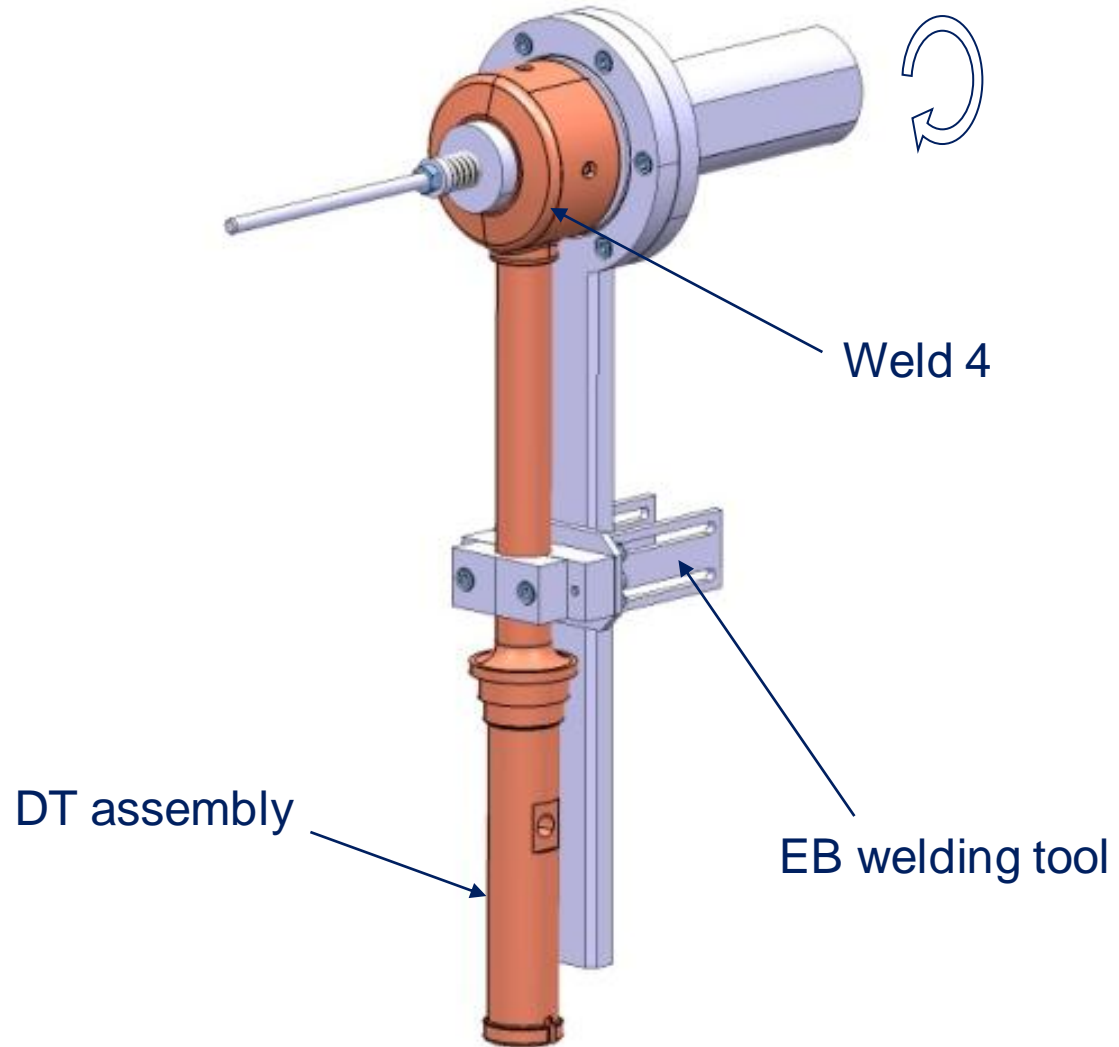

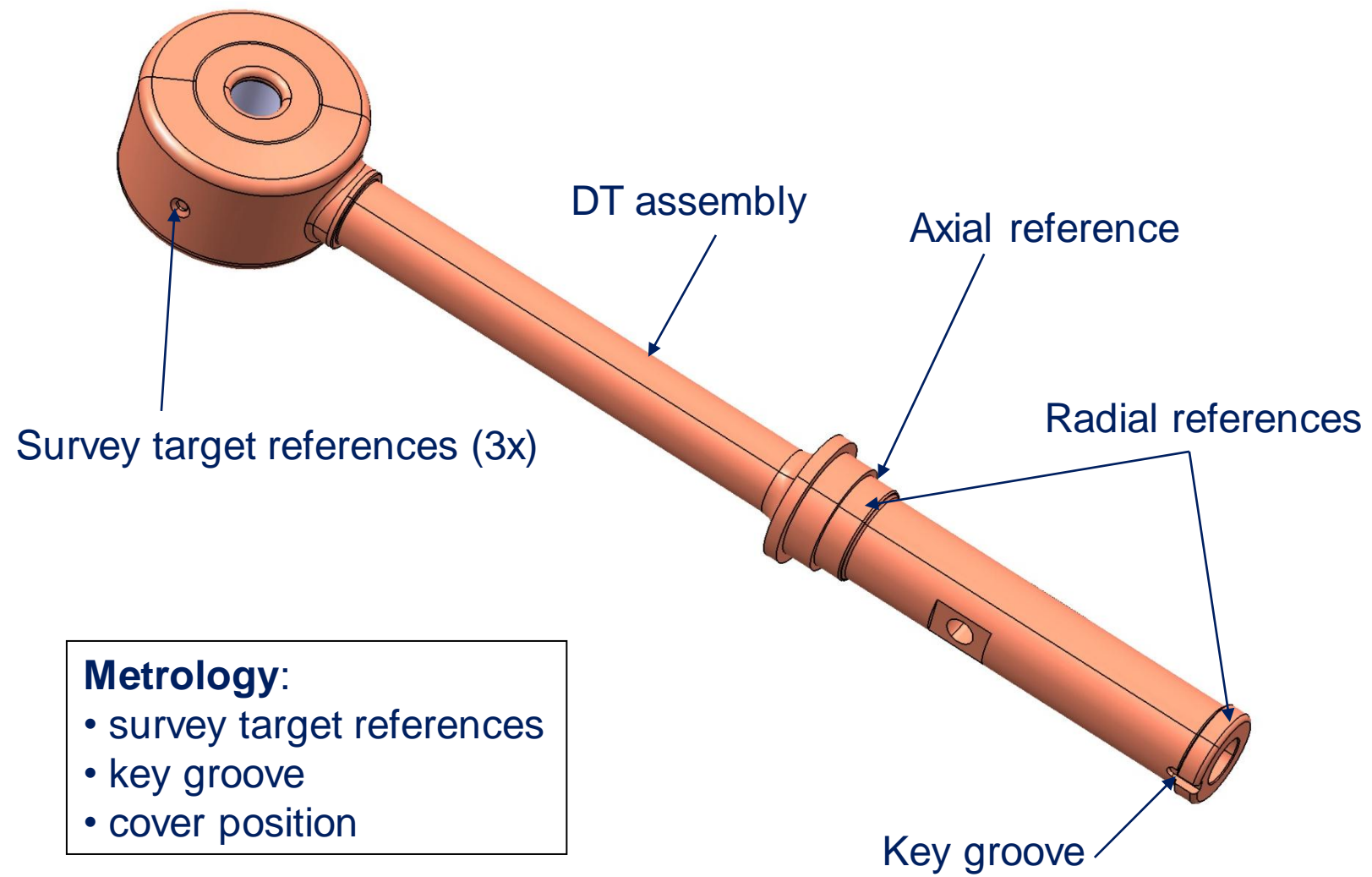

Metrology:

- survey target references
- key groove
- cover position