

# Future perspectives for $\mu^+ \rightarrow e^+ \gamma$ searches

Paolo Walter Cattaneo, INFN Pavia

Sep 4th, 2025 @ Liverpool, UK  
NuFact 2025

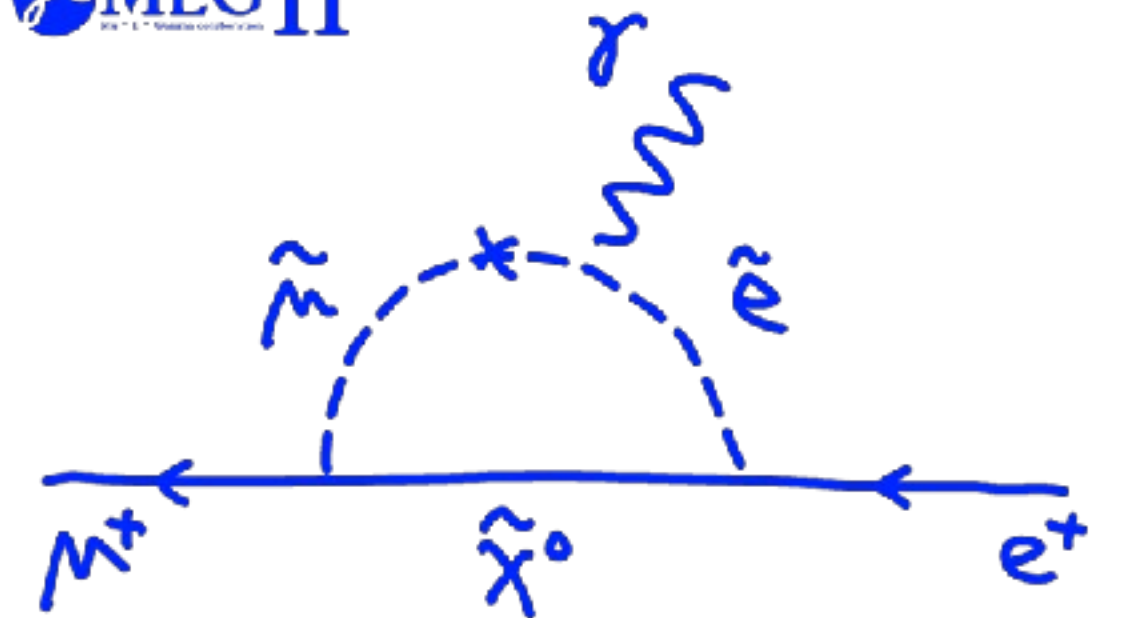

# Charged lepton flavor violation (CLFV)

- One of the most powerful probes to search for New Physics (NP)
- The conservation of the lepton flavor is an accidental symmetry in SM
  - arising from the absence of right-handed neutrinos
- This symmetry is typically lost in NP models
  - lepton flavor violation is commonly predicted at the level of the current experimental sensitivities
- Discovery of neutrino oscillations demonstrated this symmetry is not exact
  - Not sufficient to give observable cLFV effects
  - Their existence further stimulates the search for cLFV

See talk of Sei Ban ‘Charged Lepton Flavour Violation’

# Charged lepton flavor violation in Standard model (with $\nu$ mass) vs new physics

**Charged lepton flavor transition has never been observed yet**

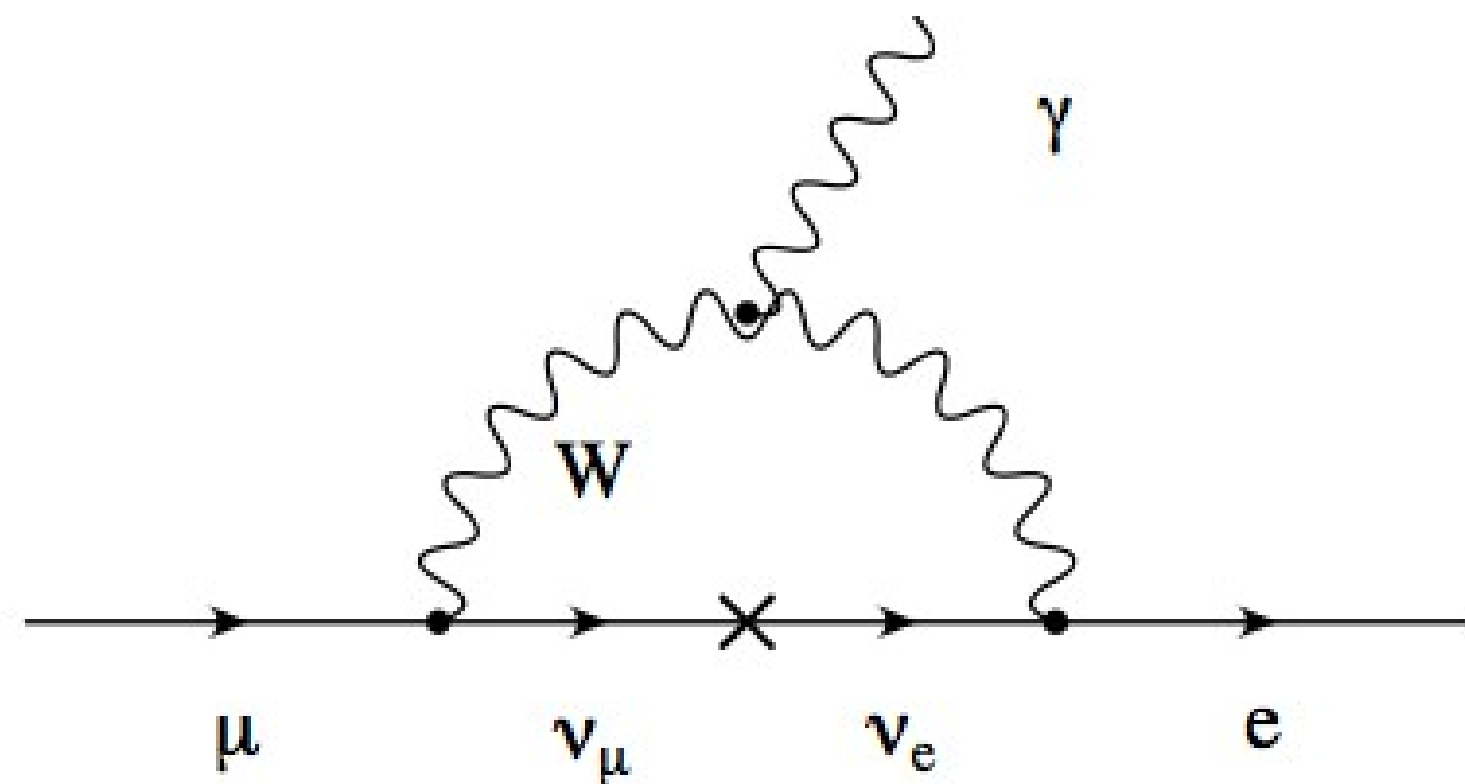

$$\text{BR}(\mu \rightarrow e\gamma) \simeq \frac{\Gamma(\mu \rightarrow e\gamma)}{\Gamma(\mu \rightarrow e\nu\bar{\nu})} = \frac{3\alpha}{32\pi} \left| \sum_{k=1,3} \frac{U_{\mu k} U_{ek}^* m_{\nu k}^2}{M_W^2} \right|^2$$

$\sim 10^{-54}$

Neutrino is too light

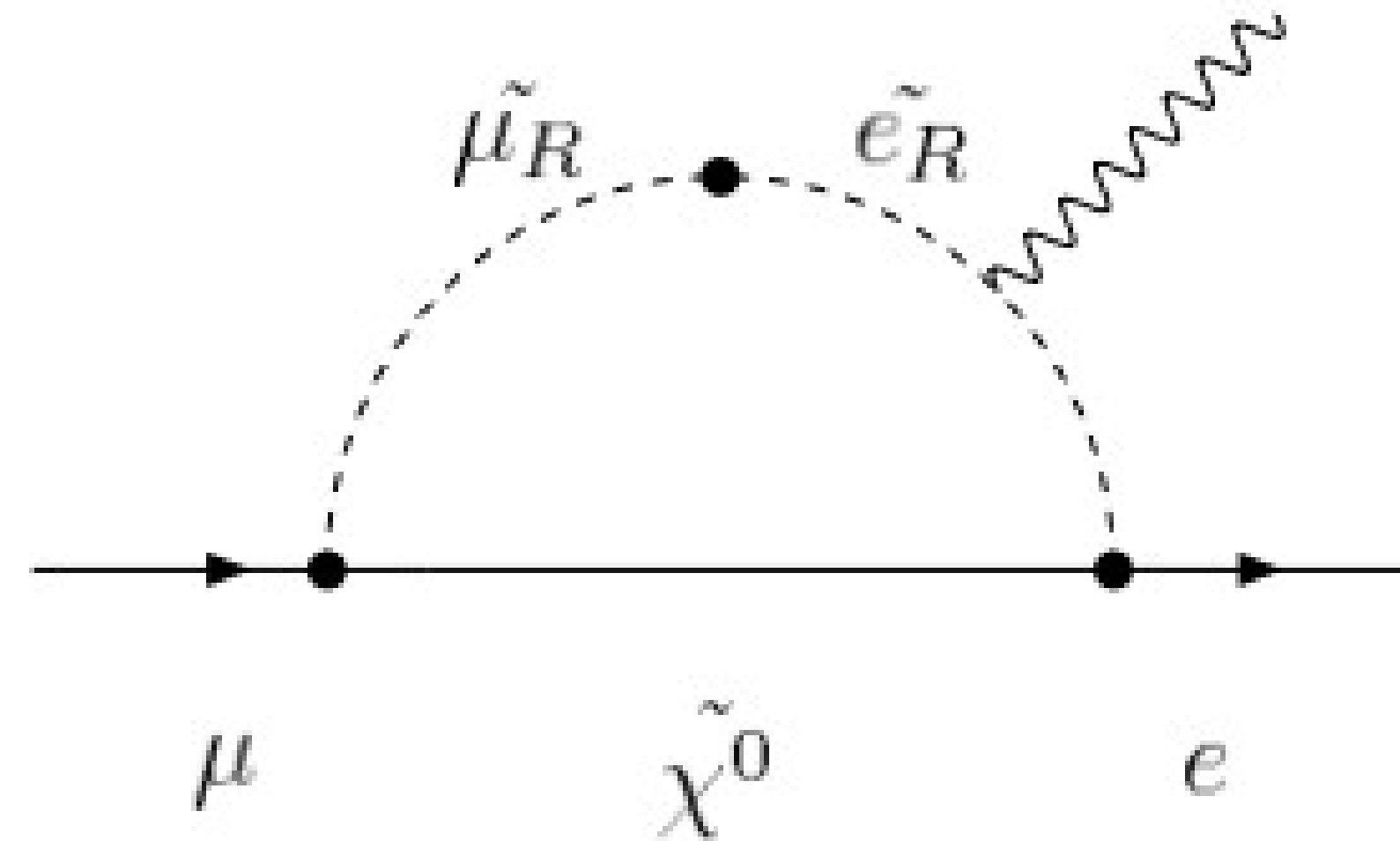

New particles from SUSY in the loop can enhance the branching ratio  $10^{-12\%-14}$

SUSY-GUT / SUSY-seesaw

**Evidence of  $\mu^+ \rightarrow e^+\gamma$  = Evidence of new physics**

$$\mu^+ \rightarrow e^+ \gamma, \quad \mu^+ \rightarrow e^+ e^- e^+, \quad \mu^- \rightarrow e^-$$

- Golden channels
  - High intensity muon beam
  - Clean signature
- Synergy to look for these decay modes at the same time
  - Maximize the discovery potential to different new physics model
  - Pin down the new physics model with independent branching ratio values after the discovery

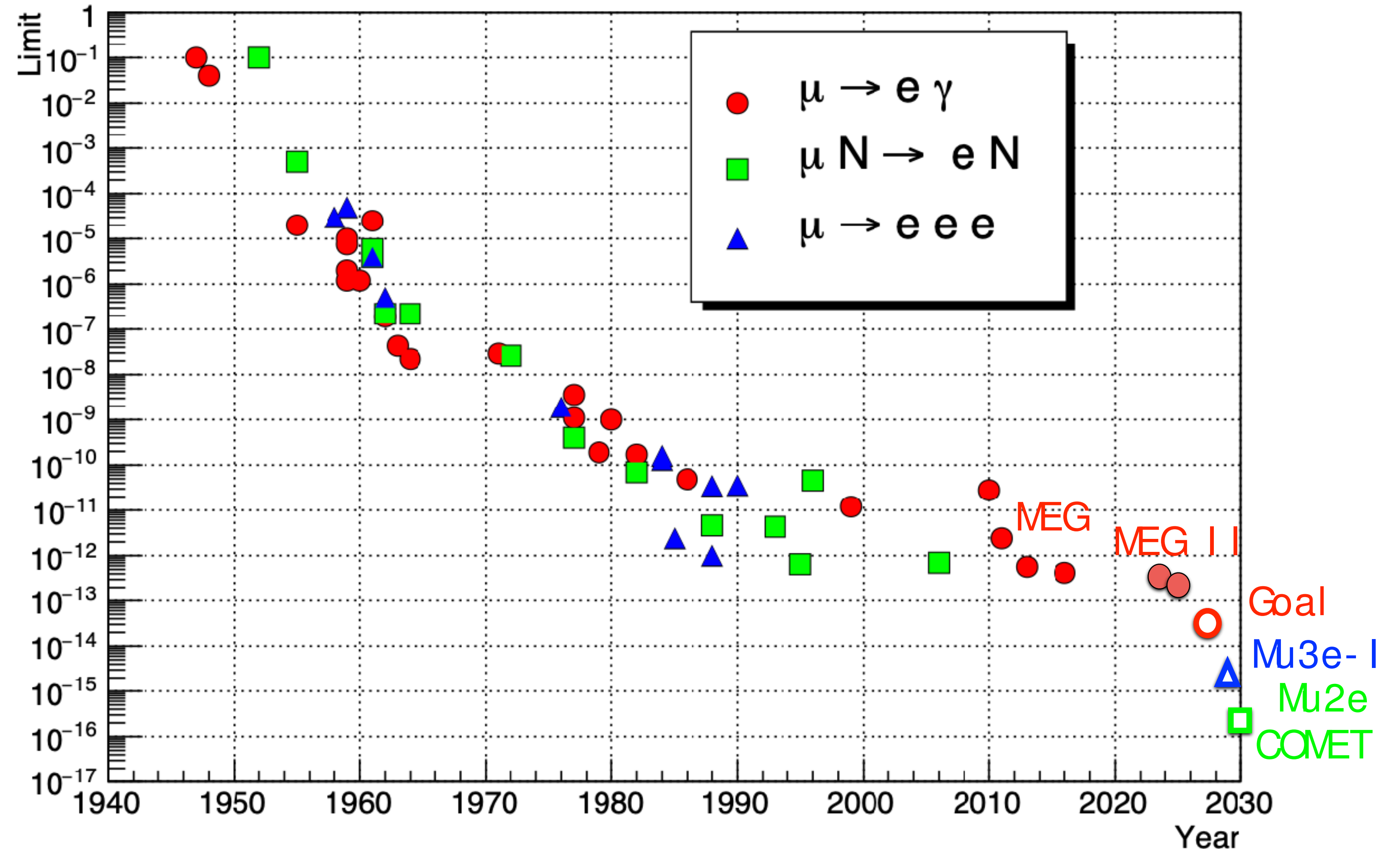

# $\mu^+ \rightarrow e^+ \gamma$ signal and backgrounds

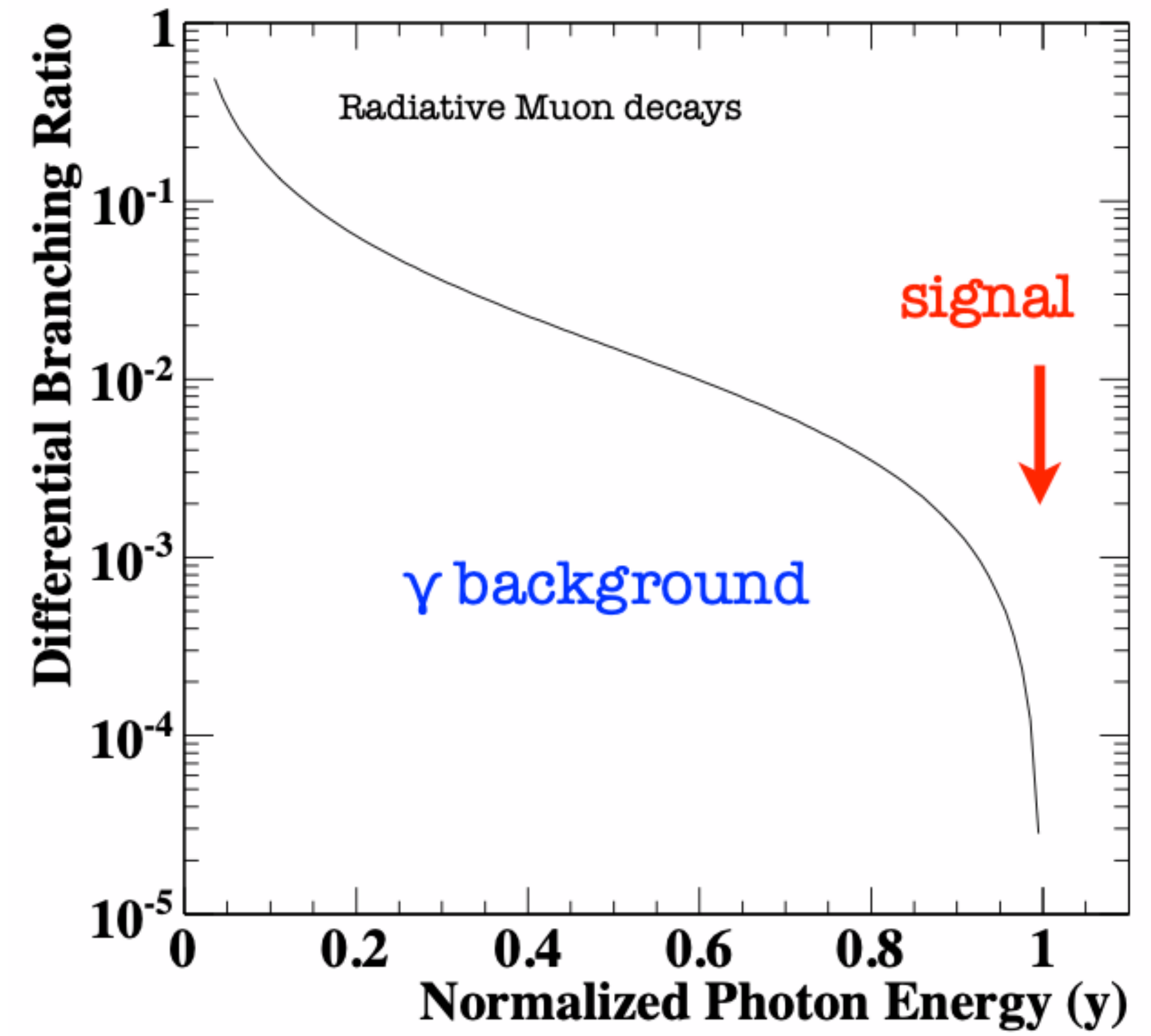
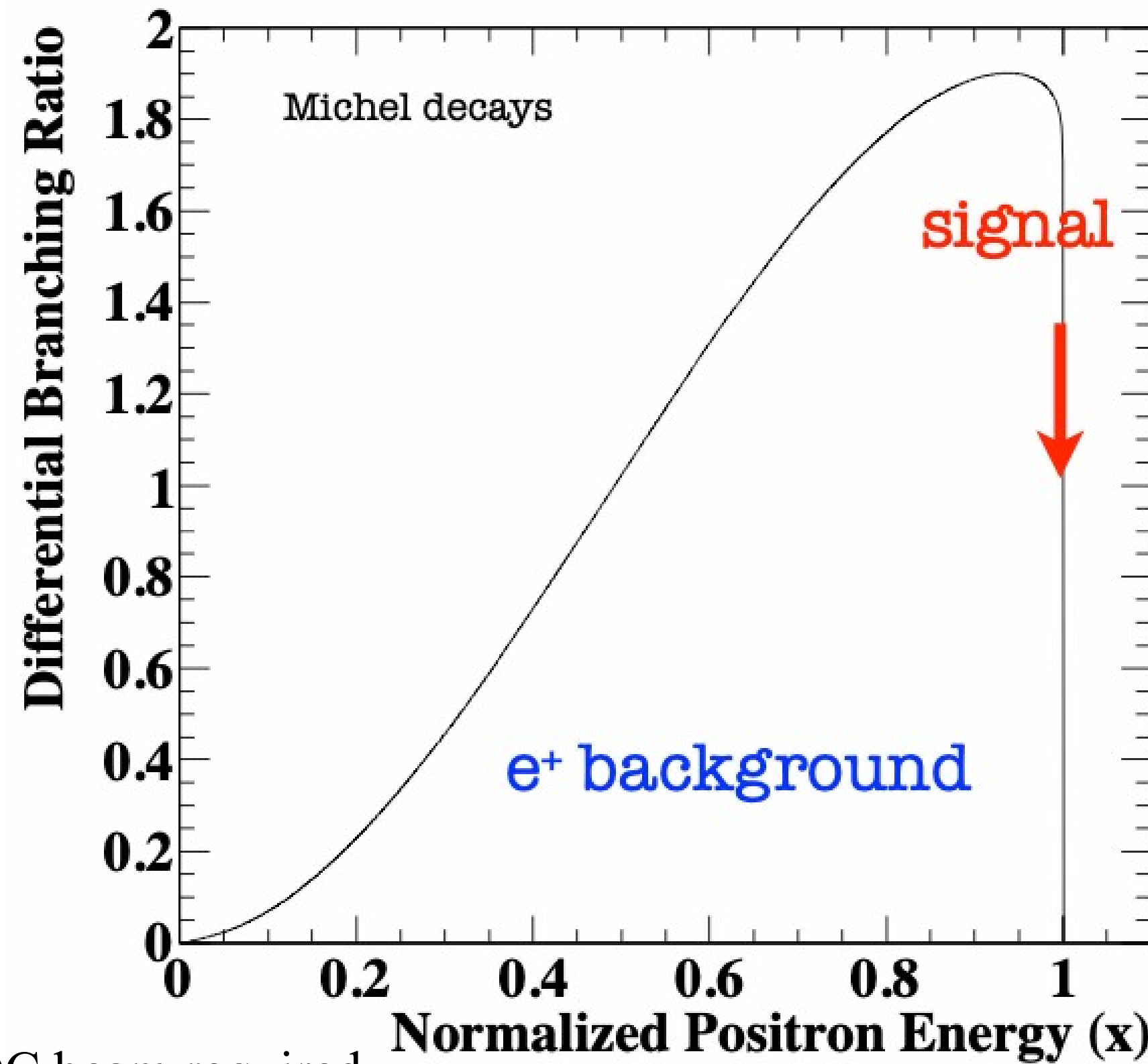
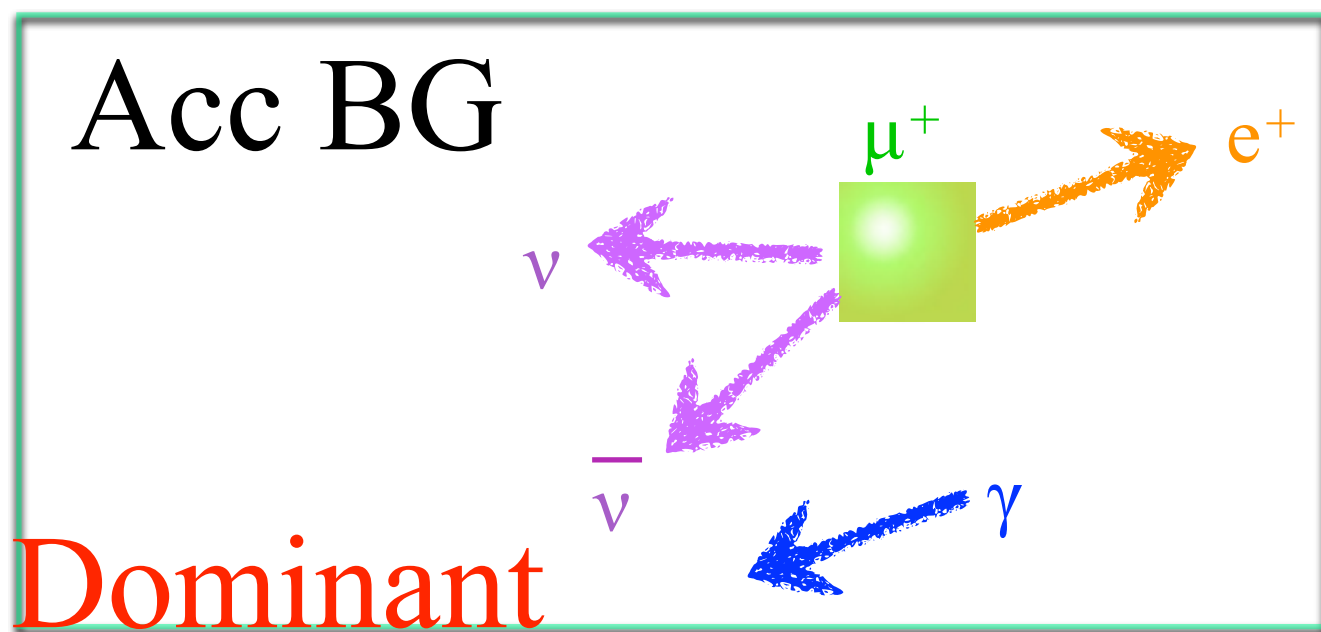
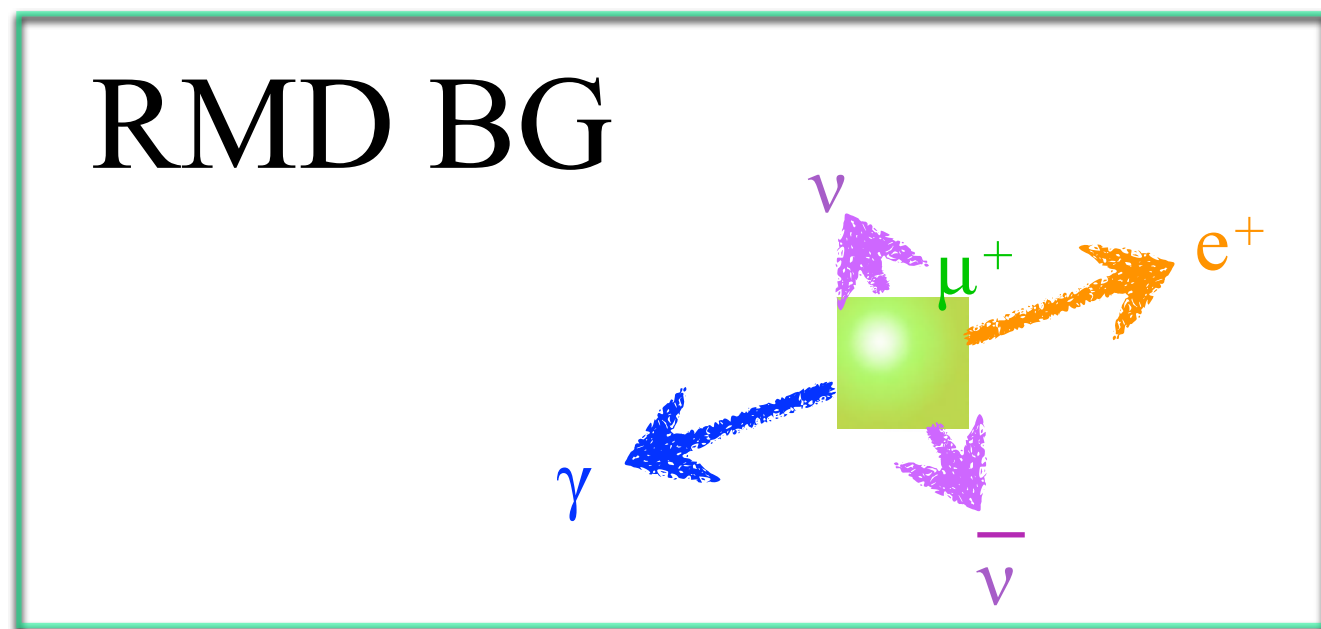
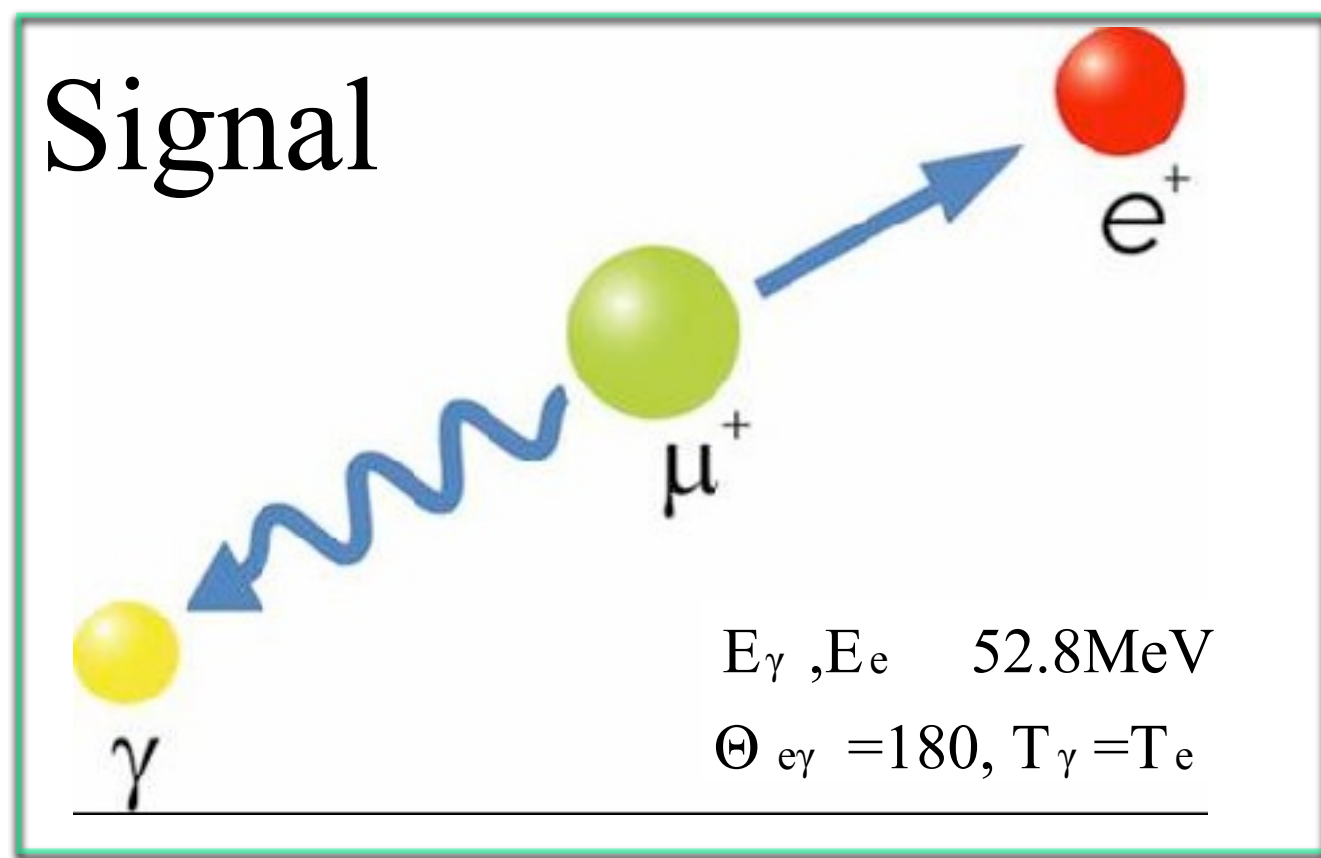

DC beam required

$$N_{\text{Sig}} \propto R_\mu \times T \times \text{Br}(\mu \rightarrow e\gamma) \times \epsilon$$

$$N_{\text{BG}} \propto R_\mu^2 \times \Delta E_\gamma^2 \times \Delta E_e \times \Delta \Theta_{e\gamma}^2 \times \Delta t_{e\gamma} \times T$$

Beam rate

Resolutions

Elapsed time

Efficiency crucial for statistics

Good resolution crucial to lower the accidental background ( $N_{\text{BG}}$ )

# Current running experiment

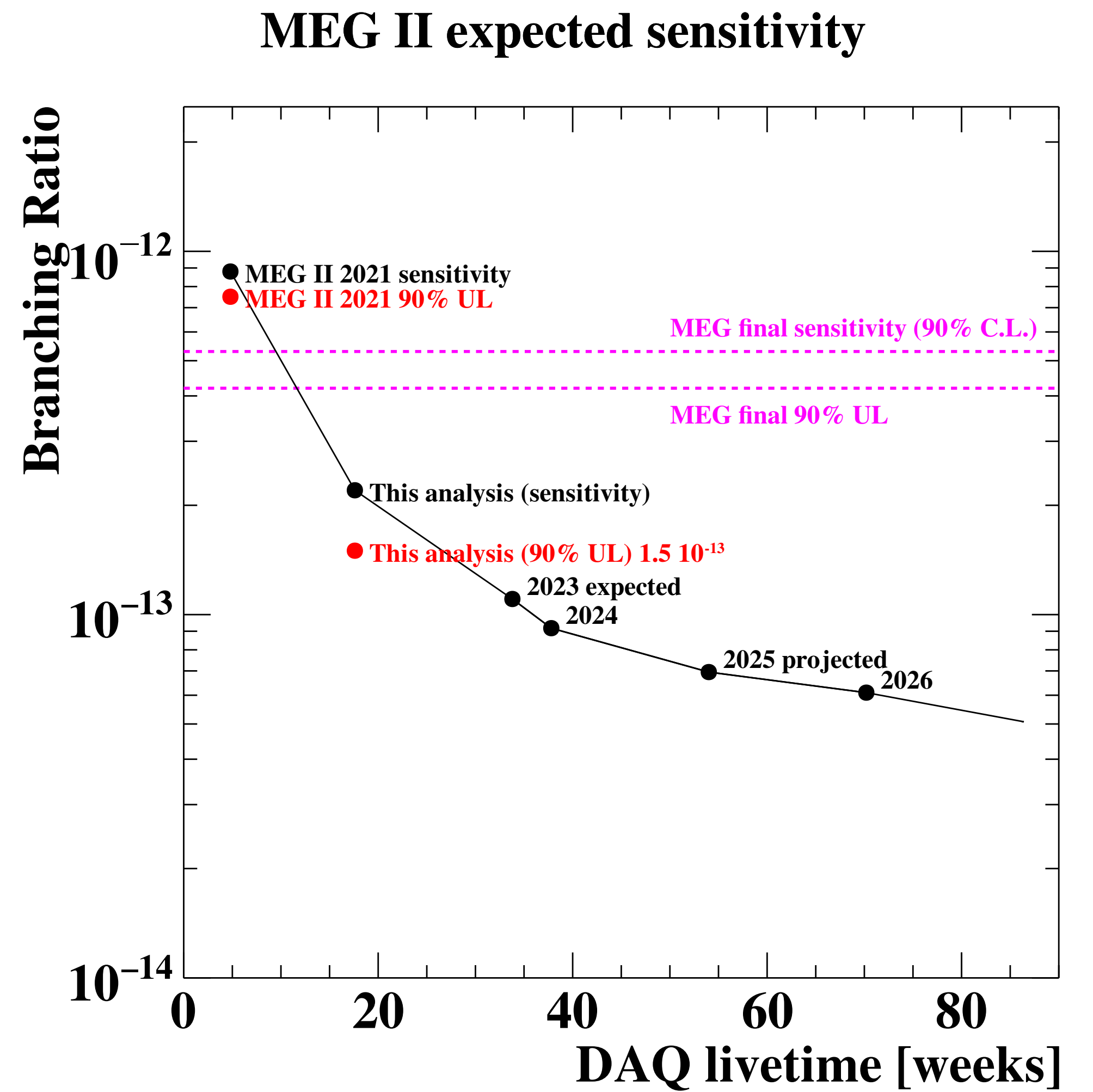
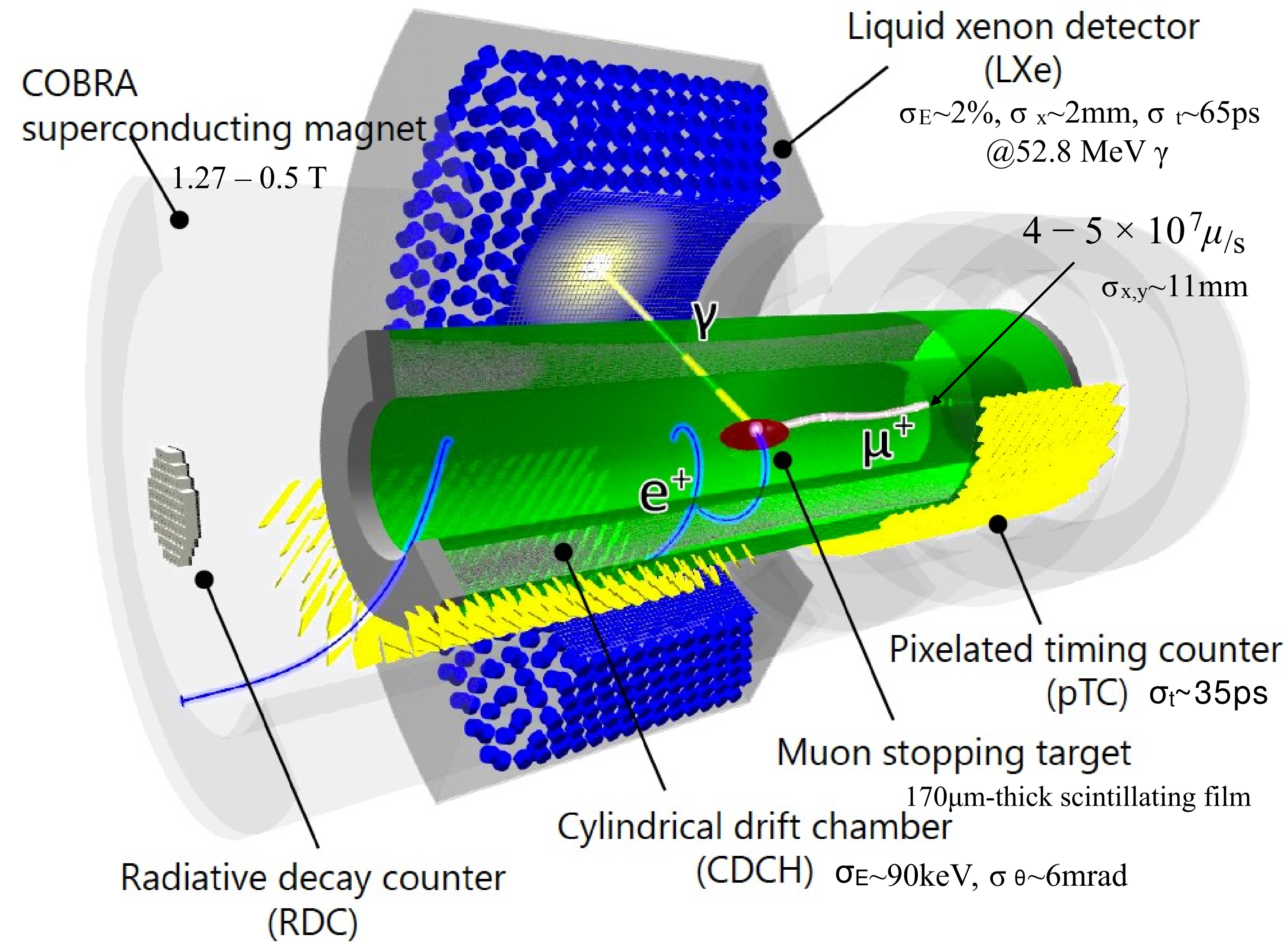

<https://arxiv.org/abs/2504.15711>

# Experiments about to begin

- Mu3e phase I, Mu2e-I, COMET: finalizing the detector construction  
 Mu3e-I: 2026, 2029–

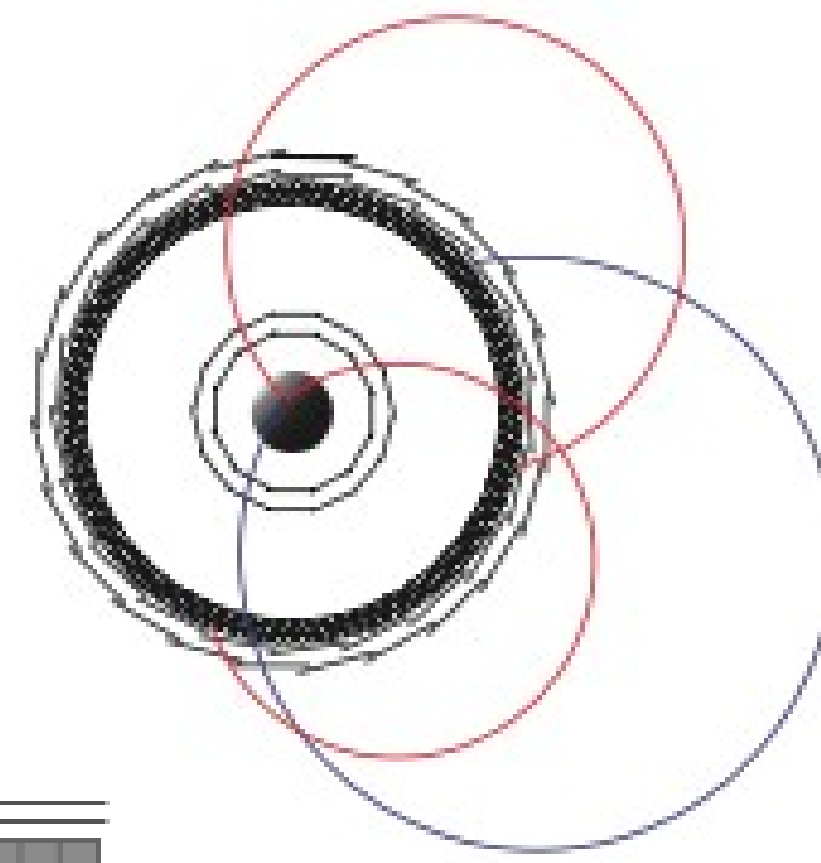

## COMET Phase-I : 2026–

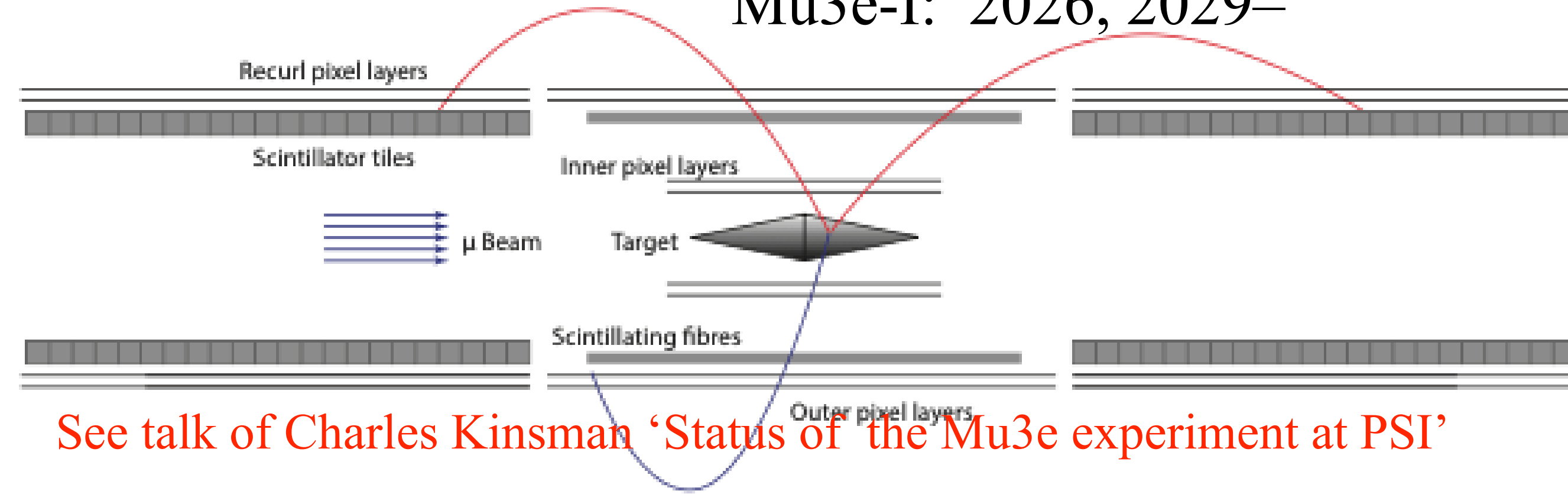
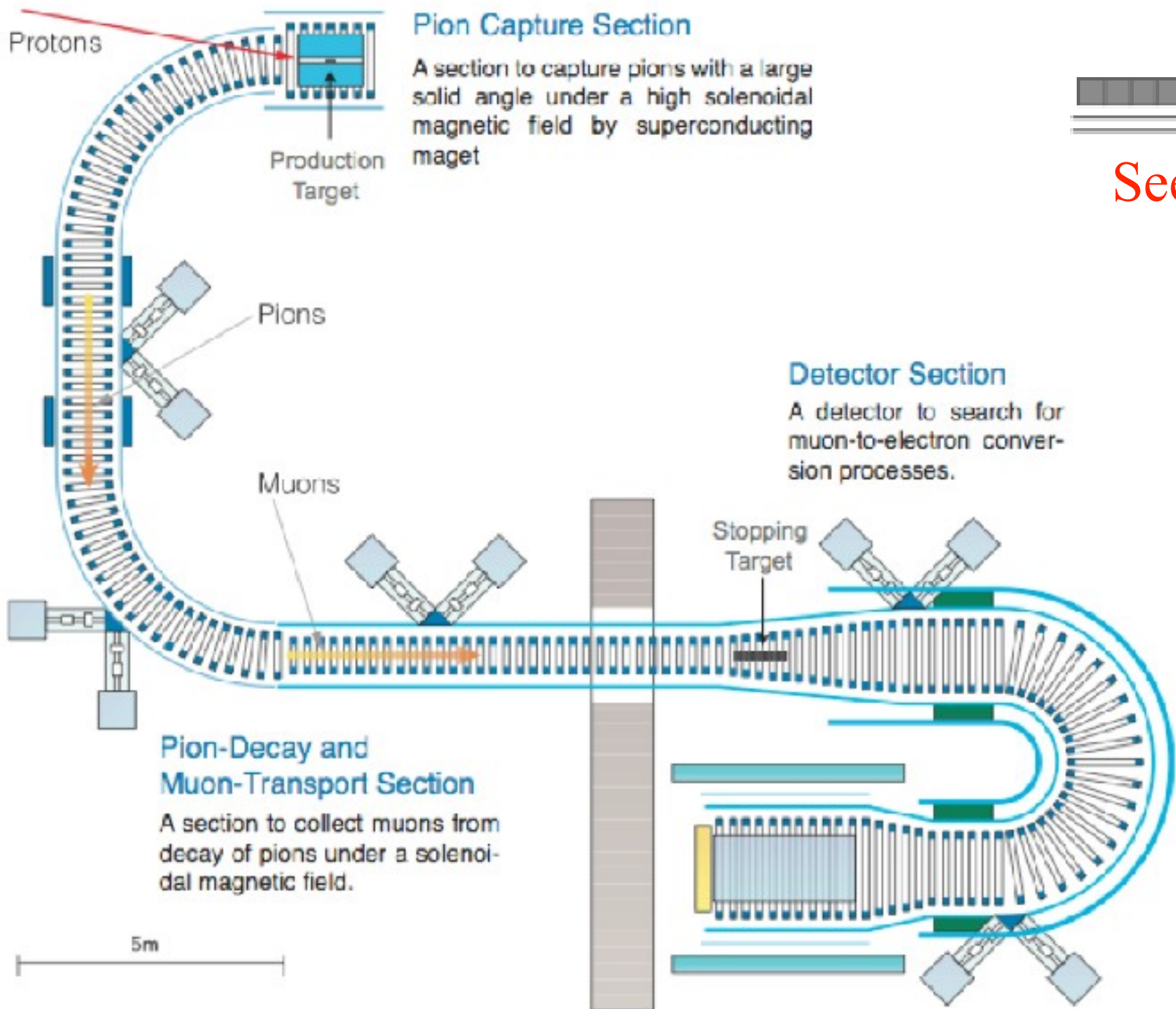

See talk of Charles Kinsman 'Status of the Mu3e experiment at PSI'

Mu2e: Run 1 2026  
 Run 2 2029–2033

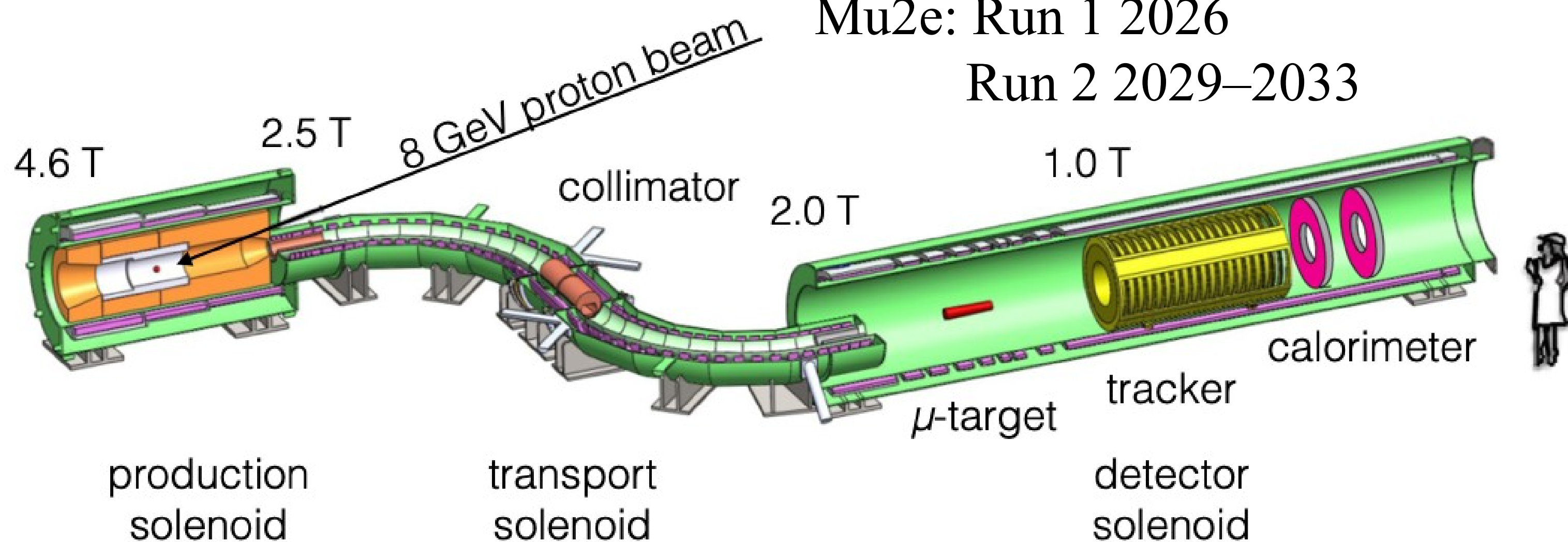

See talk of Ryo Nagai 'Current Status and Prospects of the COMET experiment at J-PARC'

See talk of Namitha Chithirasreemadam 'Status of the Mu2e experiment'

# Paul Scherrer Institute (PSI) in Switzerland

PSI 590MeV proton cyclotron  
 2.4mA, 1.4MW in Switzerland  
 produces  $> 1 \times 10^8 \mu/s$   
 world's highest intense DC muon beam

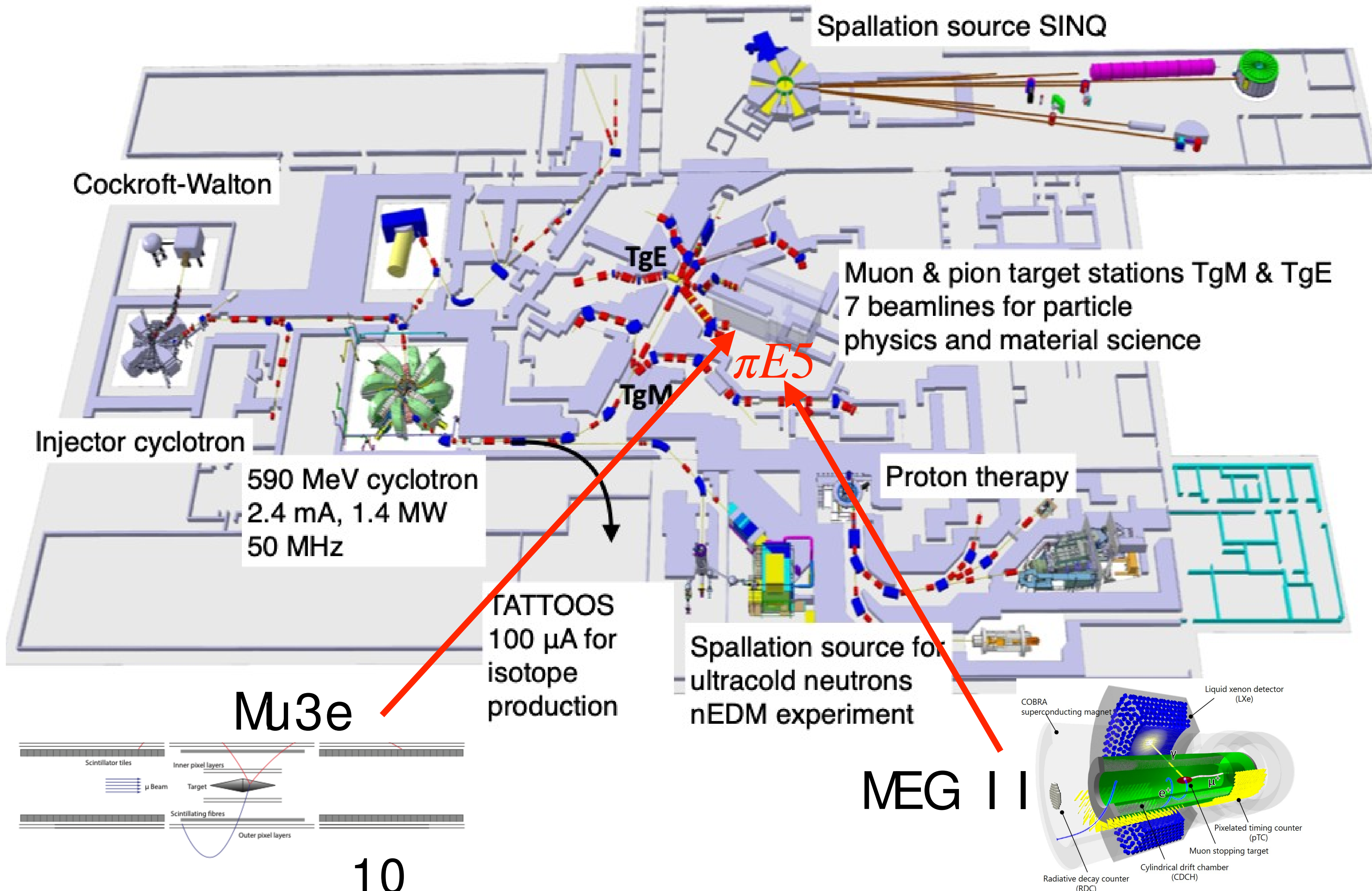
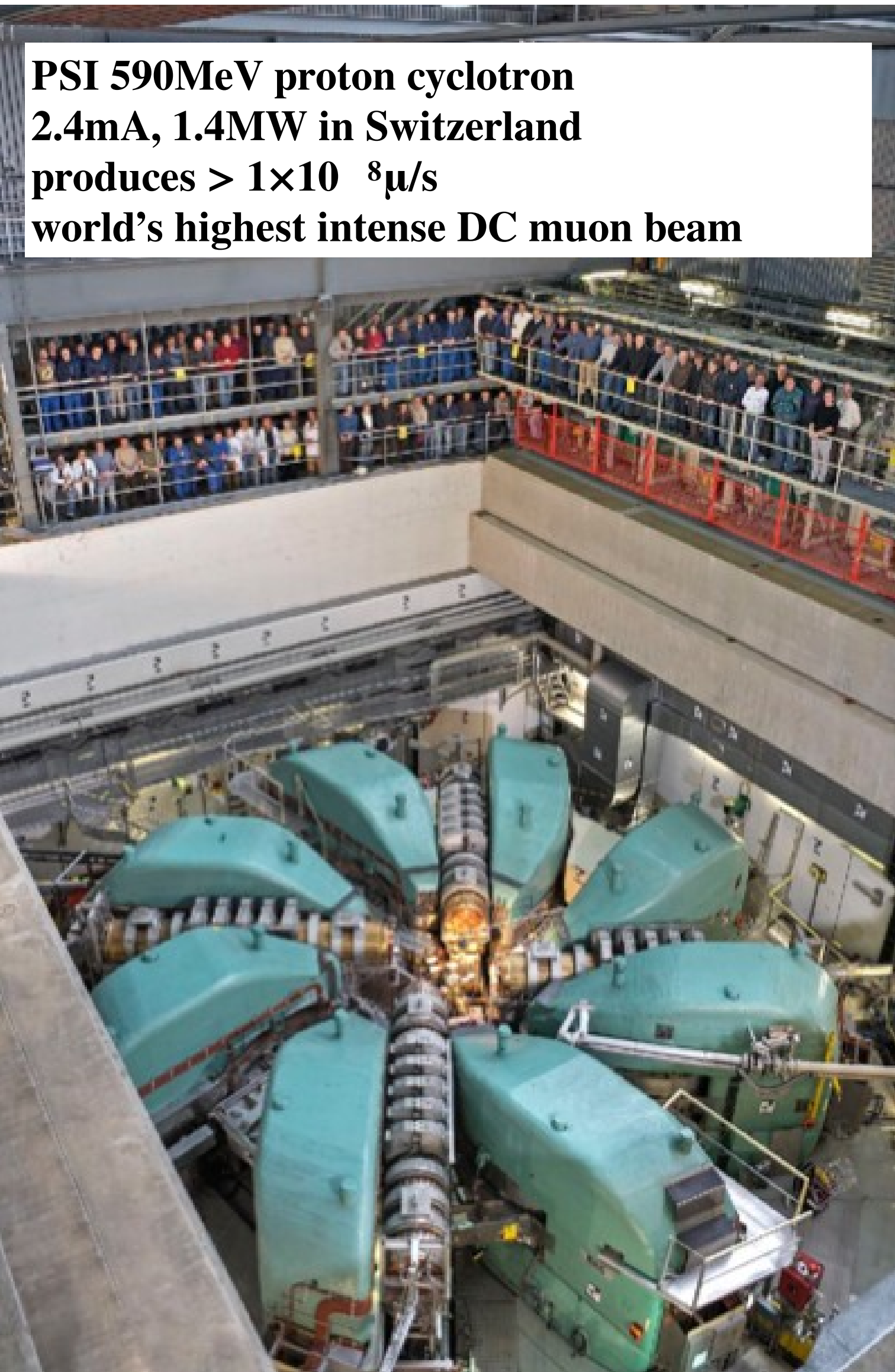

# High intensity muon beam line @ PSI

- Shutdown of about two years from 2027
- New target geometry, 4 times capture efficiency, 6 times transport efficiency, resulting in  $> 10^{10} \mu/s$  ( $5 \times 10^8 \mu/s$  now) available from late 2028
- Beam spot  $\sigma \sim 40\text{mm}$

See talk of Andreas Knecht 'Future muon facilities'

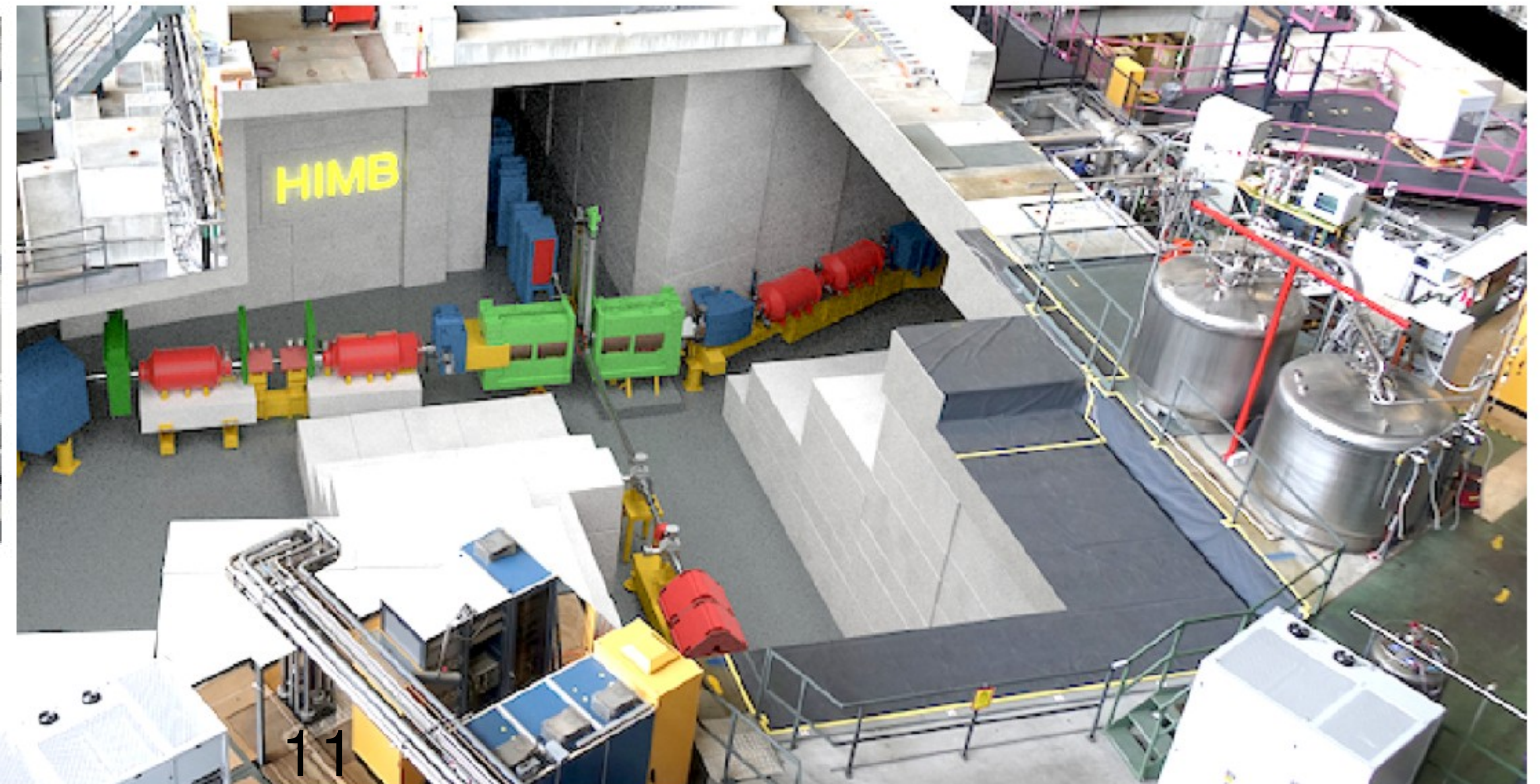
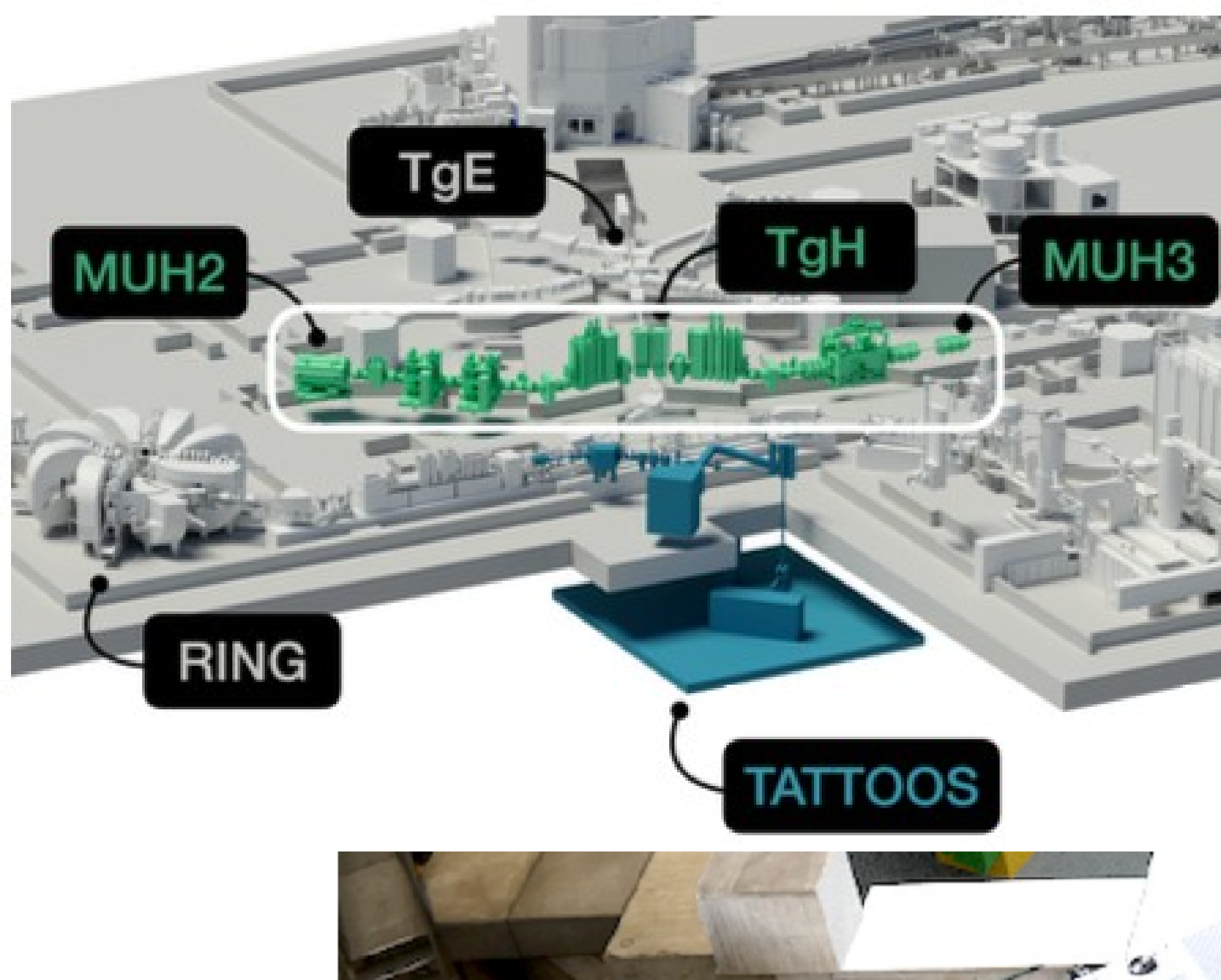
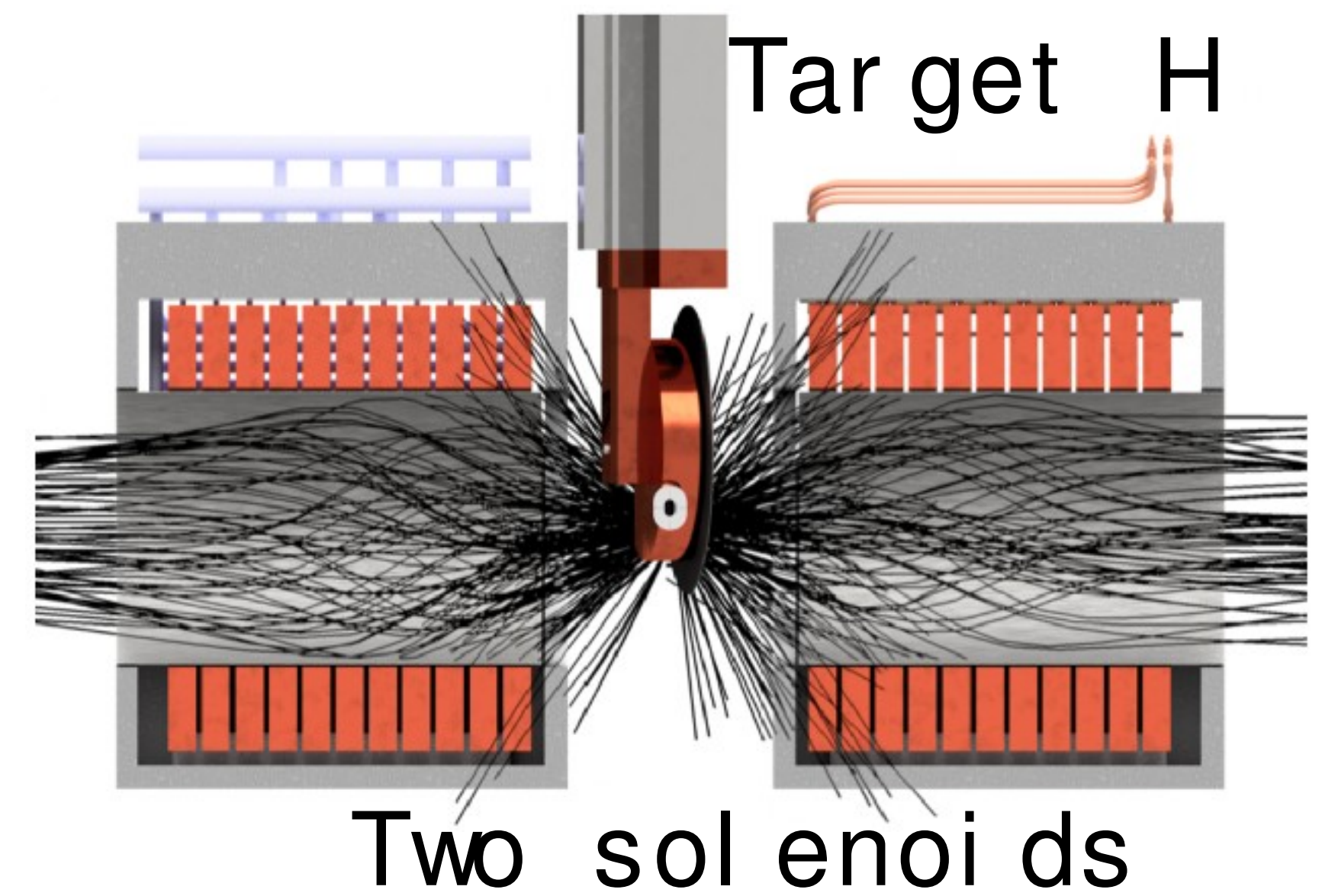

# Muon facilities in the world

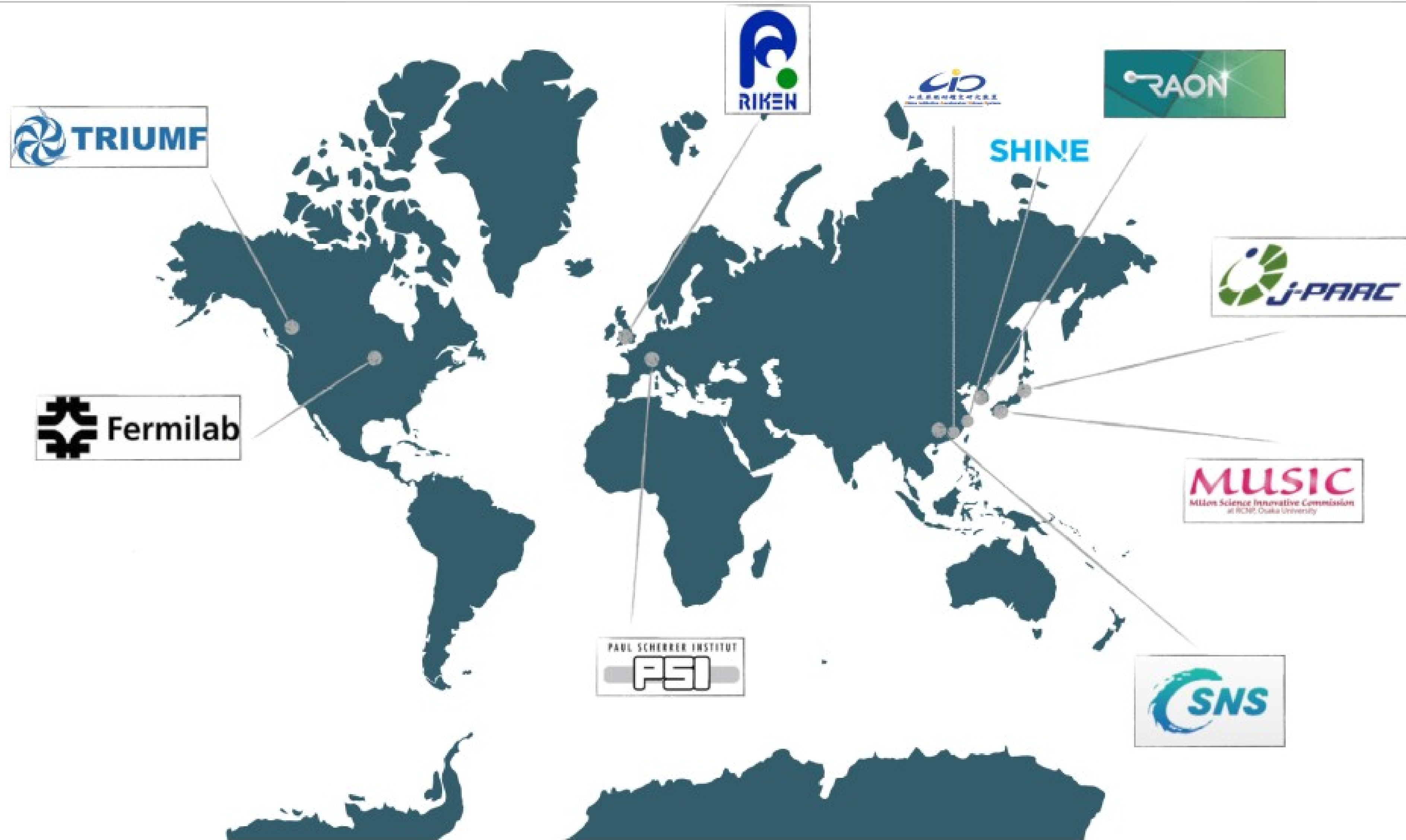

# Future $\mu^+ \rightarrow e^+ \gamma$

[arXiv:2504.18831](https://arxiv.org/abs/2504.18831)

- Sensitivity of  $\mu \rightarrow e\gamma$  searches is limited by the background from accidental coincidences

$$N_{\text{Sig}} \propto R_{\mu} \times T \times \text{Br}(\mu \rightarrow e\gamma) \times \varepsilon$$

$$N_{\text{BG}} \propto R_{\mu}^2 \times \Delta E_{\gamma}^2 \times \Delta E_e \times \Delta \Theta_{e\gamma}^2 \times \Delta t_{e\gamma} \times T$$

- Improvements in detector resolutions inevitable to exploit beam rates up to  $10^9$ - $10^{10}$   $\mu$ /s
- Large acceptance ( $\varepsilon$ ) to gain statistics while beam intensity is as high as possible without degrading resolutions
- R&D of new detector concept (resolutions, efficiency, rate capability) is underway

Calorimeter

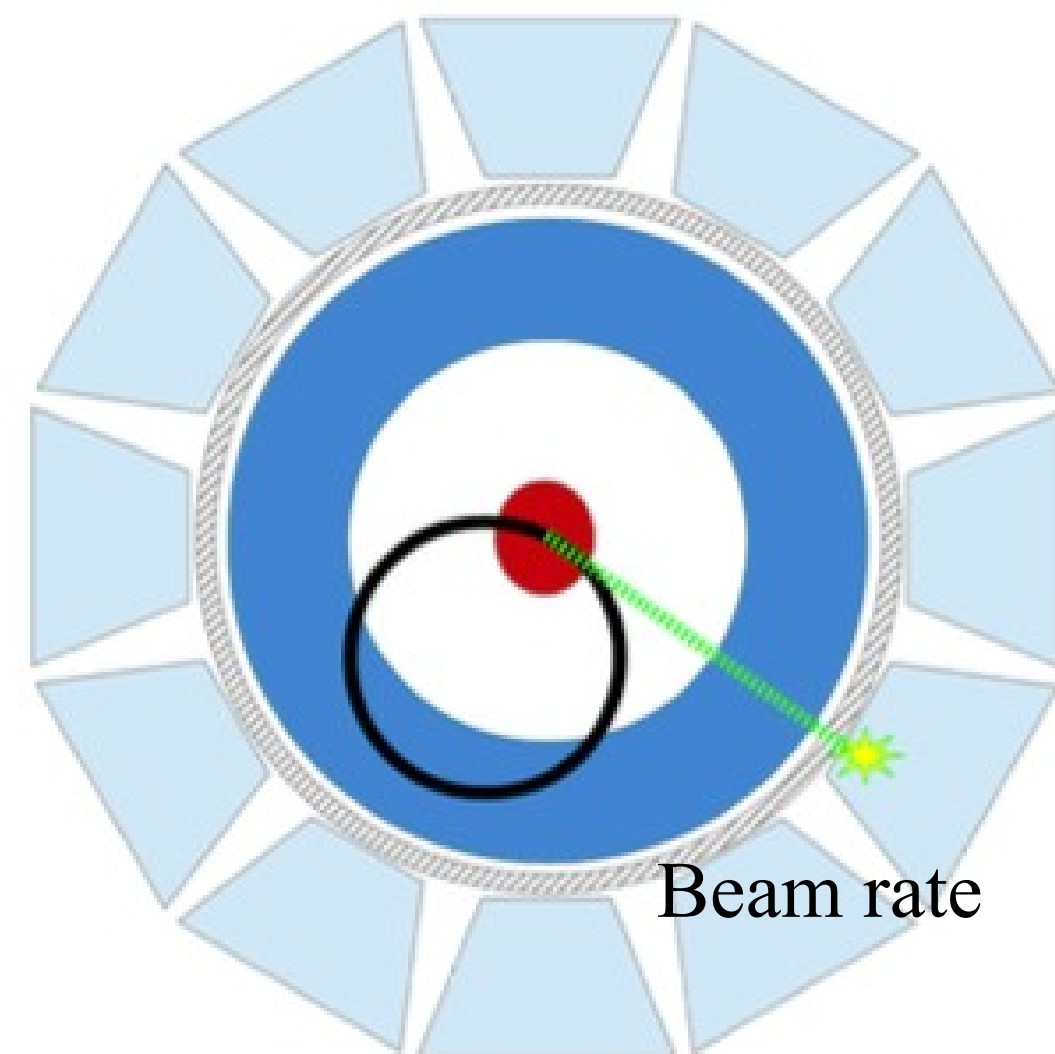

Photon conversion

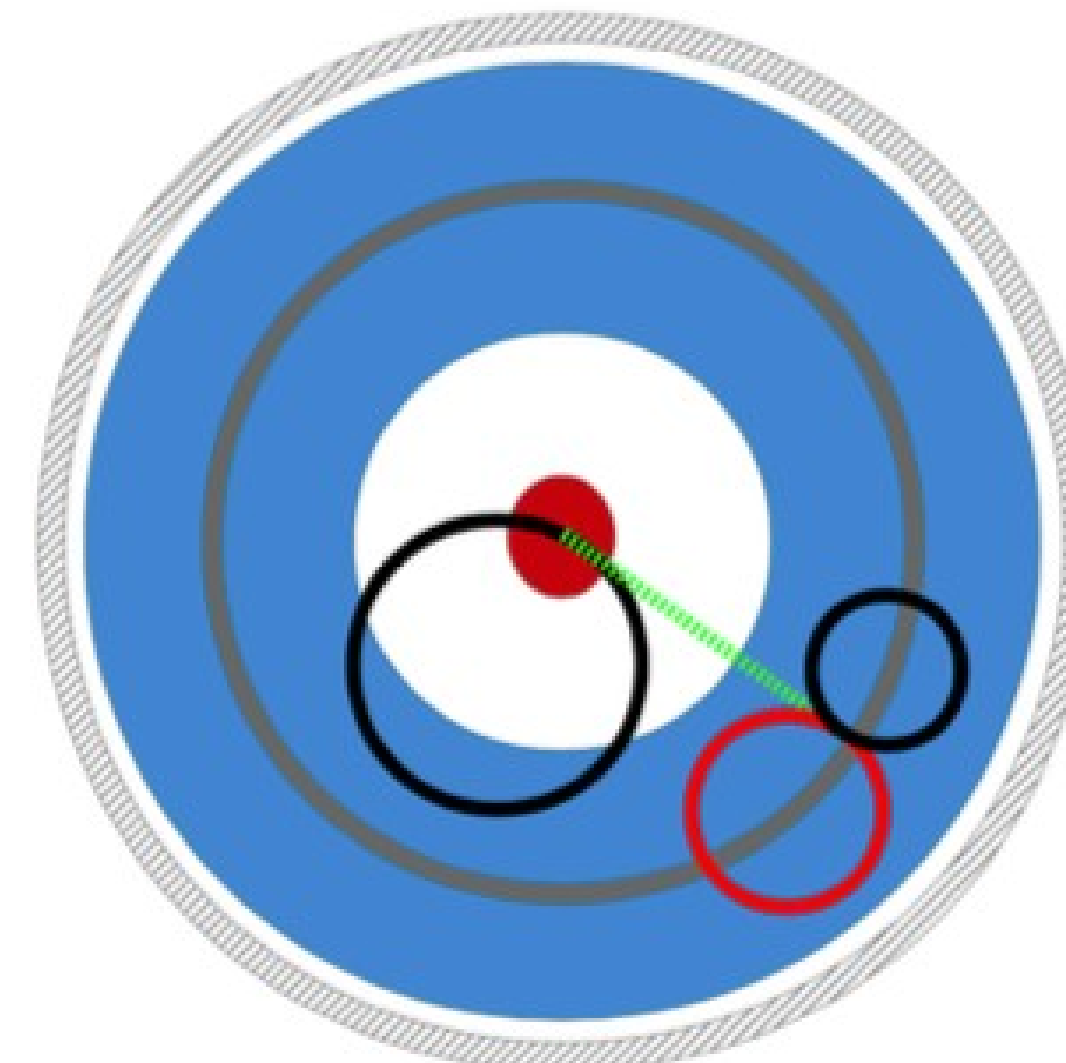

# Sensitivity with Calorimeter vs Conversion

Photon conversion may achieve better resolution than calorimetry and is less sensitive to pileup

It is a better solution at high beam intensity, if positron resolution is unchanged

But positron efficiency and resolution get worse when the beam intensity increases ...

Retaining high positron efficiency and resolution at high beam intensity is key to improve the sensitivity

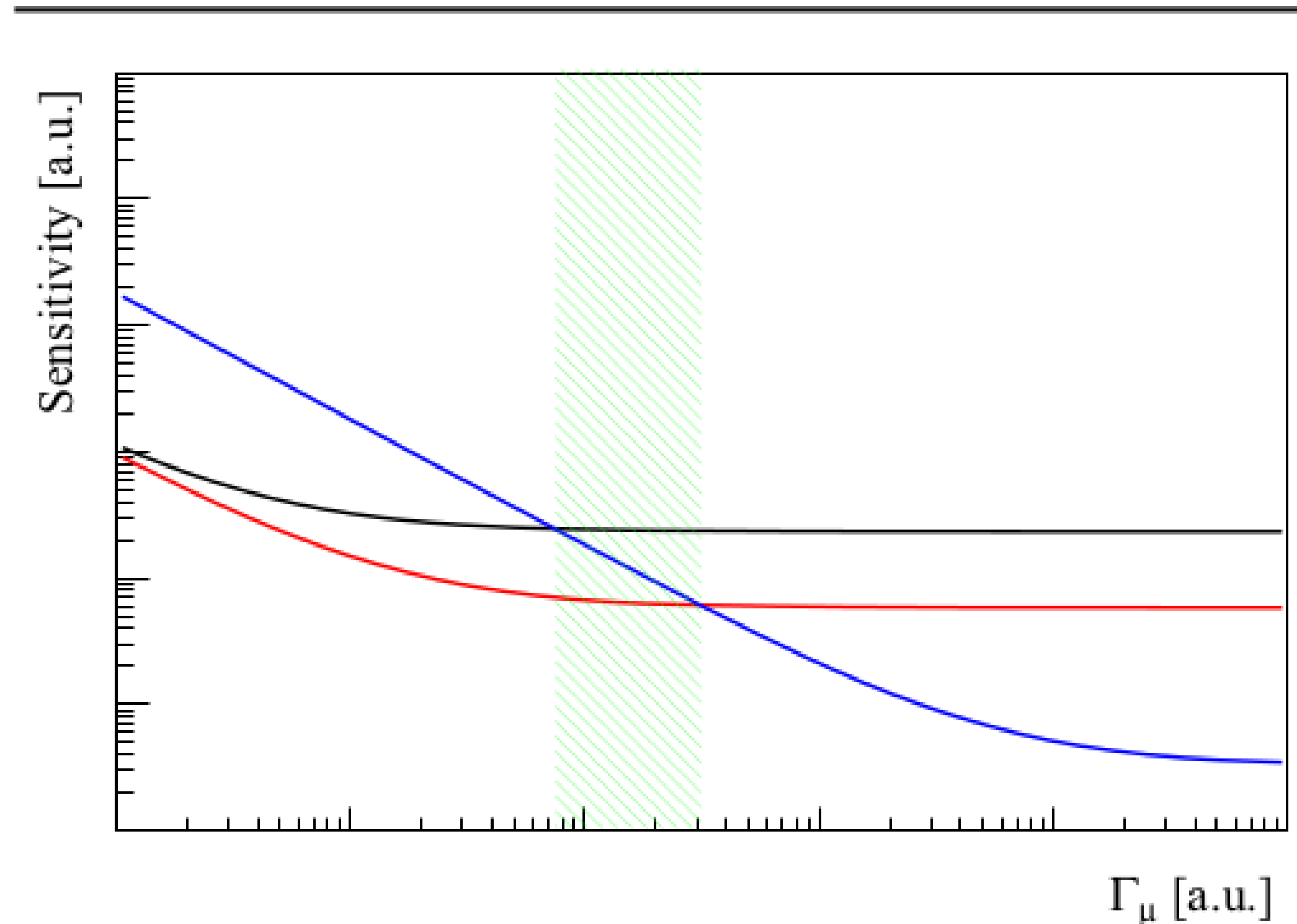
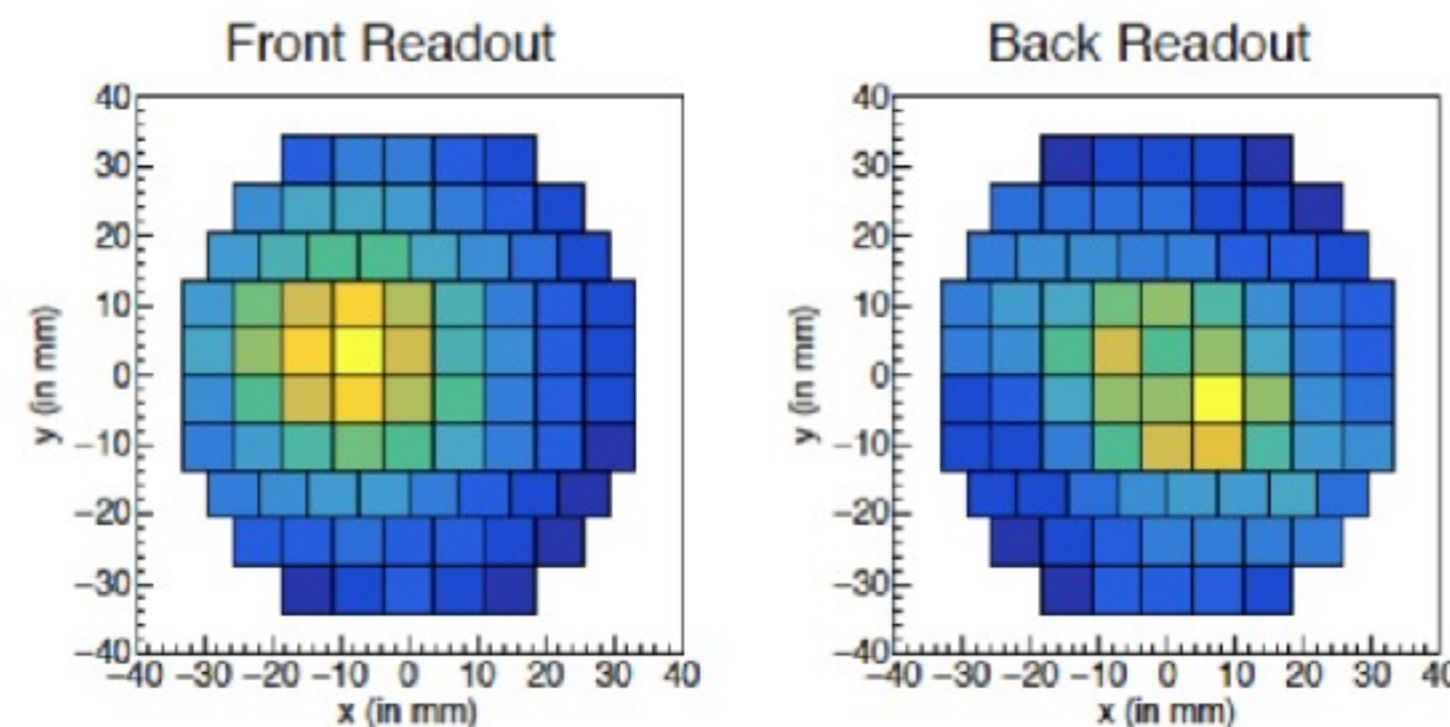
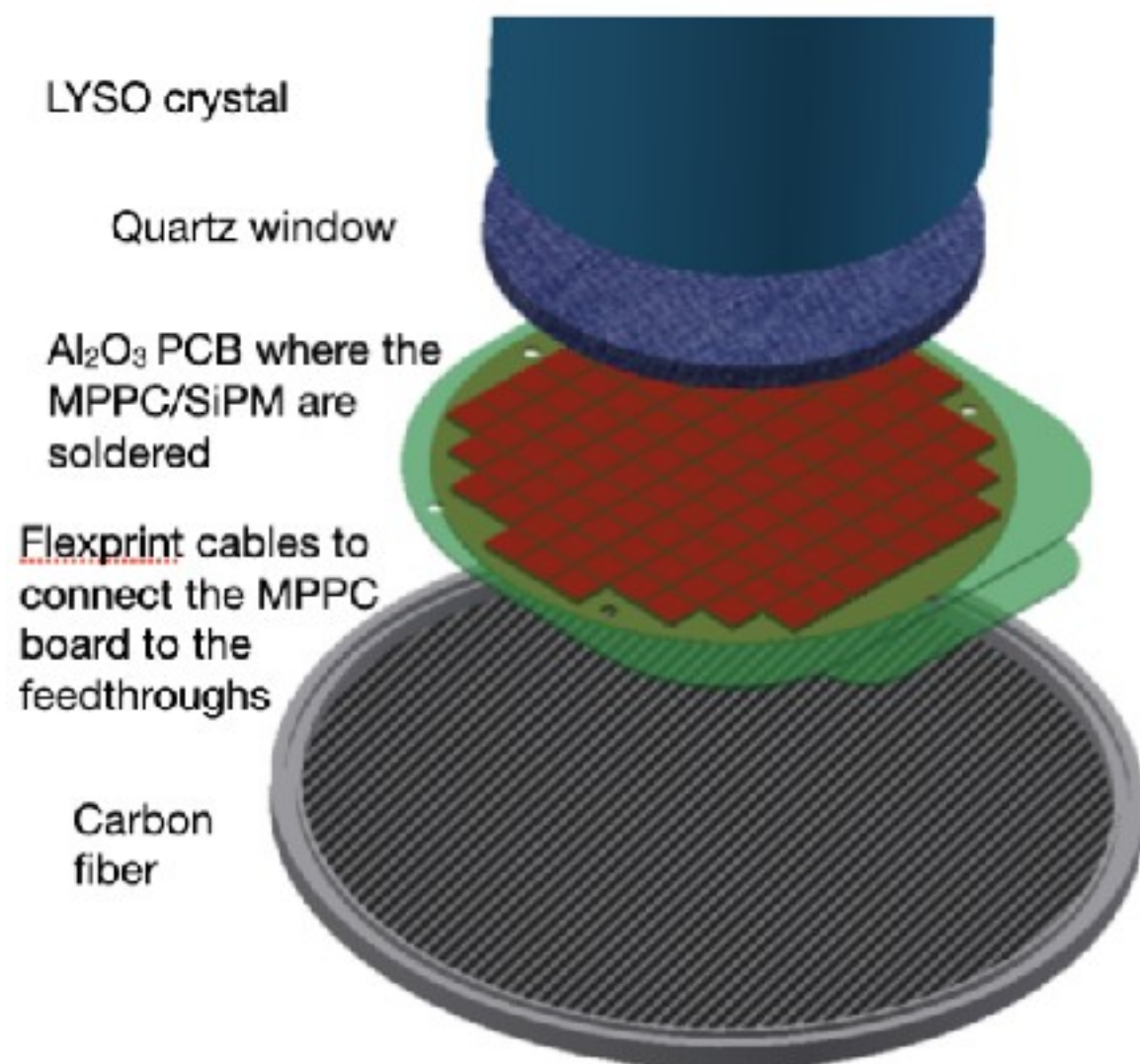

**Fig. 2** Sensitivity trends as a function of the beam intensity, for a calorimetry-based design (black), a photon-conversion-based design with unchanged positron resolutions (blue) and a calorimetry-based design with a factor two improvement in resolutions (red). See the text for a detailed description

# Photon measurement : Calorimeter

- Two promising materials
  - LaBr<sub>3</sub>(Ce) and LYSO with SiPM readout
- Limiting factor could be capability of growing large crystals and their cost
  - Interesting option for an intermediate phase in a staged approach

Some R&D is ongoing



(a) Hit in Central Region:  $(x, y) = (-10 \text{ mm}, 3 \text{ mm})$

- Expected performances:
- $\sigma_E/E$  [%] = 1.7(1)
  - $\sigma_t$  [ps] = 35(1)
  - $\sigma_{t,x,y,z}$  [mm] = 3-5

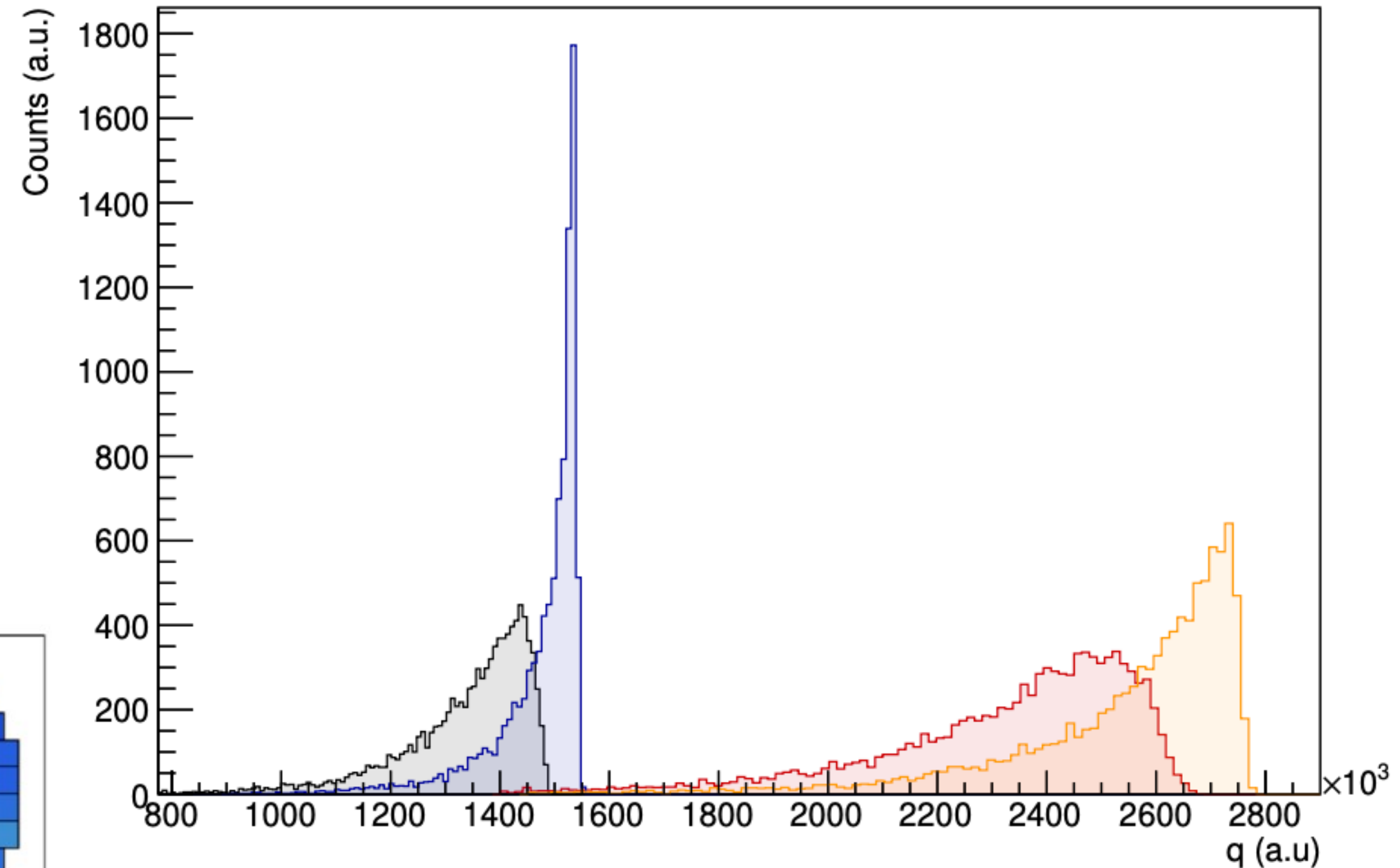

	D = 7 cm, L = 16 cm, LYSO	$\sigma/\mu = 1.69(6) \%$
	D = 9 cm, L = 20 cm, LaBr <sub>3</sub> (Ce)	$\sigma/\mu = 2.52(8) \%$
	D = 15 cm, L = 16 cm, LYSO	$\sigma/\mu = 0.444(10) \%$
	D = 15 cm, L = 20 cm, LaBr <sub>3</sub> (Ce)	$\sigma/\mu = 0.94(3) \%$

# Detector with Photon Converter

- Design: Based on photon pair spectrometer embedded in a large solenoid
  - Photon spectrometer with active converter: higher resolutions (energy, timing, position), angle
  - Positron spectrometer with high rate capability
  - Separate active (?) targets: higher vertex resolution, further BG suppression
  - Significantly improved acceptance

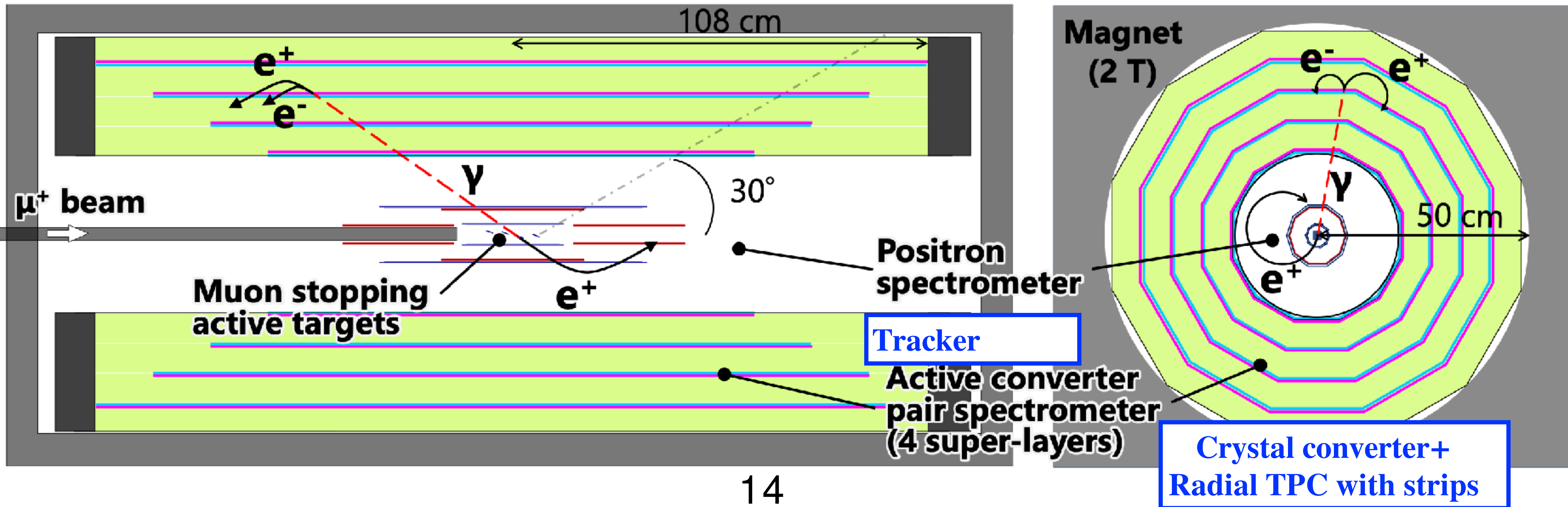

# Toroid

Toroidal B field direction:

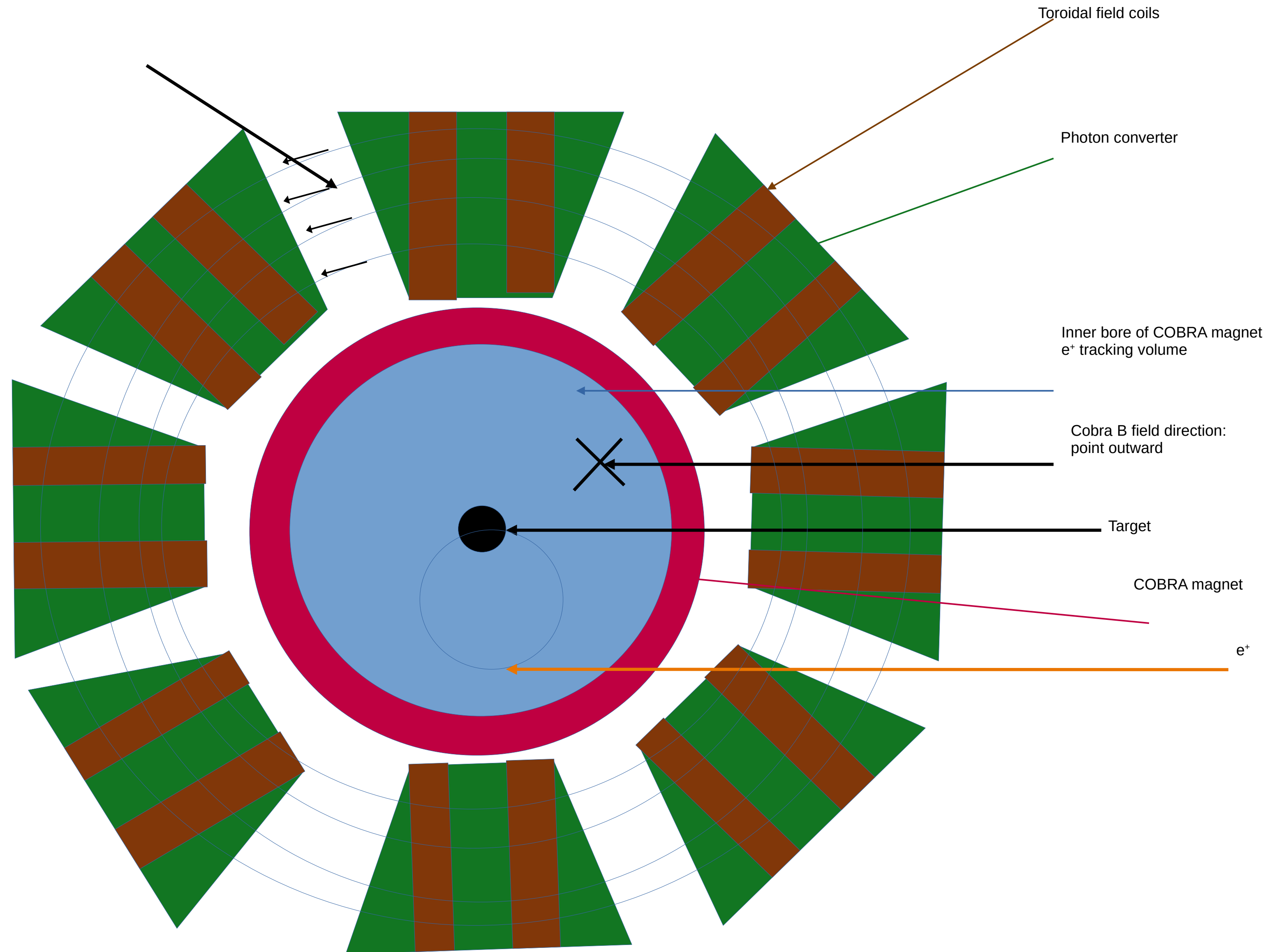

## Why a toroidal magnet?

- Preserve COBRA for  $e^+$  tracking saving money and time
- Separate tracking volumes for  $e^+$  from  $\mu^+$  and for  $e^-e^+$  from  $\gamma$
- Magnetic field intensity and configurations for  $e^+$  from  $\mu^+$  and for  $e^-e^+$  from  $\gamma$  can be tuned separately
- Tracking detectors inside the coils (e.g. TPC) can be planar not cylindrical
- Facilitate staging of the detector

## Why not a toroidal magnet?

- The radial size can be larger
- Absorbers can be required between sectors to remove  $e^-e^+$
- Some  $\gamma$  can be absorbed before interaction in active converters (small effect?)

Toroidal B field direction:

The  $\gamma$  converter are active crystals (LYSO)

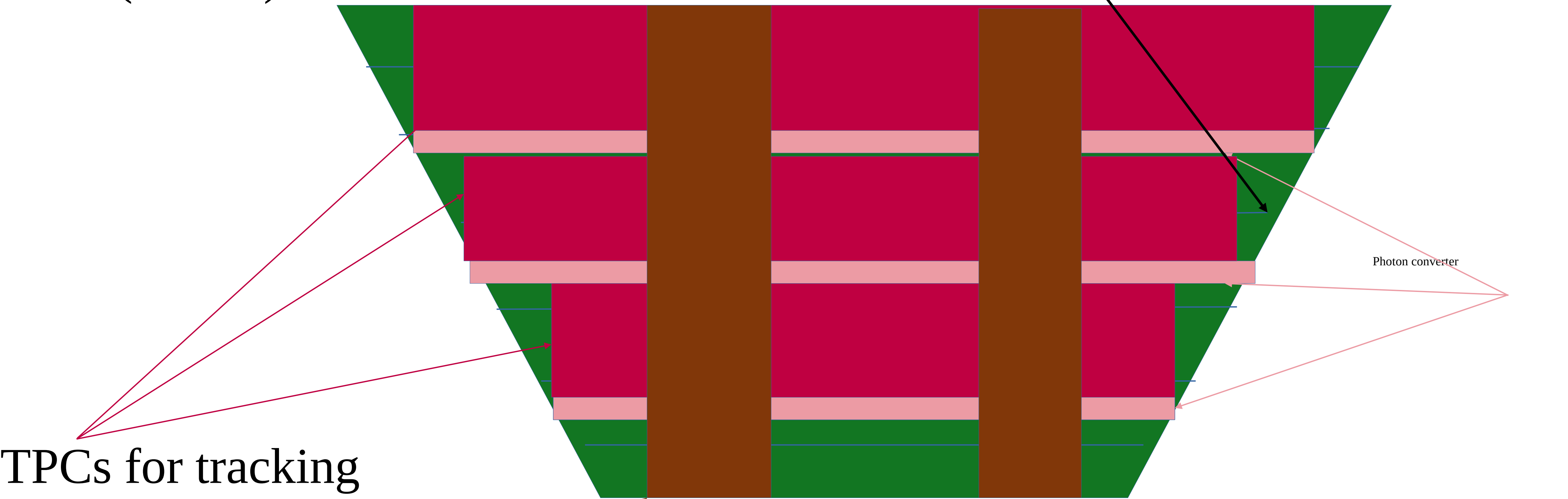

TPCs for tracking

Photon converter

Toroidal field coils

The  $e^+/e^-$  trajectories are curved perpendicular to the plane

# Photon measurement: Pair Spectrometer with Active Converter

Active converter avoids energy loss undetected

- Tracking in a magnetic spectrometer
  - Drift chamber
  - Radial-TPC
  - Silicon detector

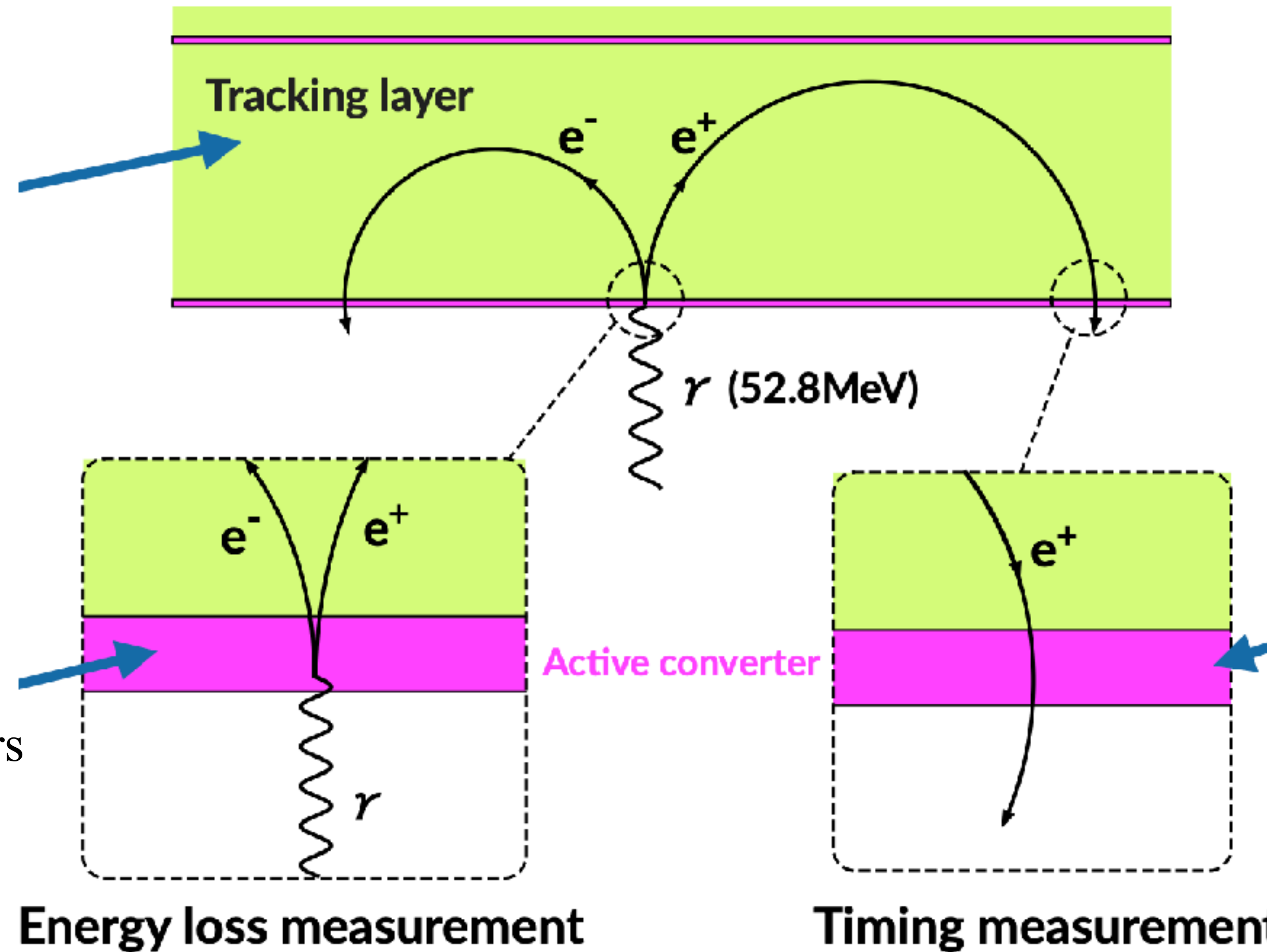

- Active converter
  - A layer of dense material to convert photons into  $e^+e^-$  pairs
  - Crystal+SiPM
  - Scintillator+SiPM
  - Silicon detector

- Timing measurement
  - Measure timing of returning conversion pair in front of active converter
  - Multi-layer RPC
  - Active converter = timing detector

Target performance:  $\sigma_E/E = 0.4\%$  ,  $\sigma_t = 30ps$  ,  $\sigma_x = 0.2mm$   
 (MEG II :  $\sigma_E/E = 1.8\%$  ,  $\sigma_t = 65ps$  ,  $\sigma_x = 2.5mm$ )

# Current R&D

- Active converter material and size are evaluated by simulation study

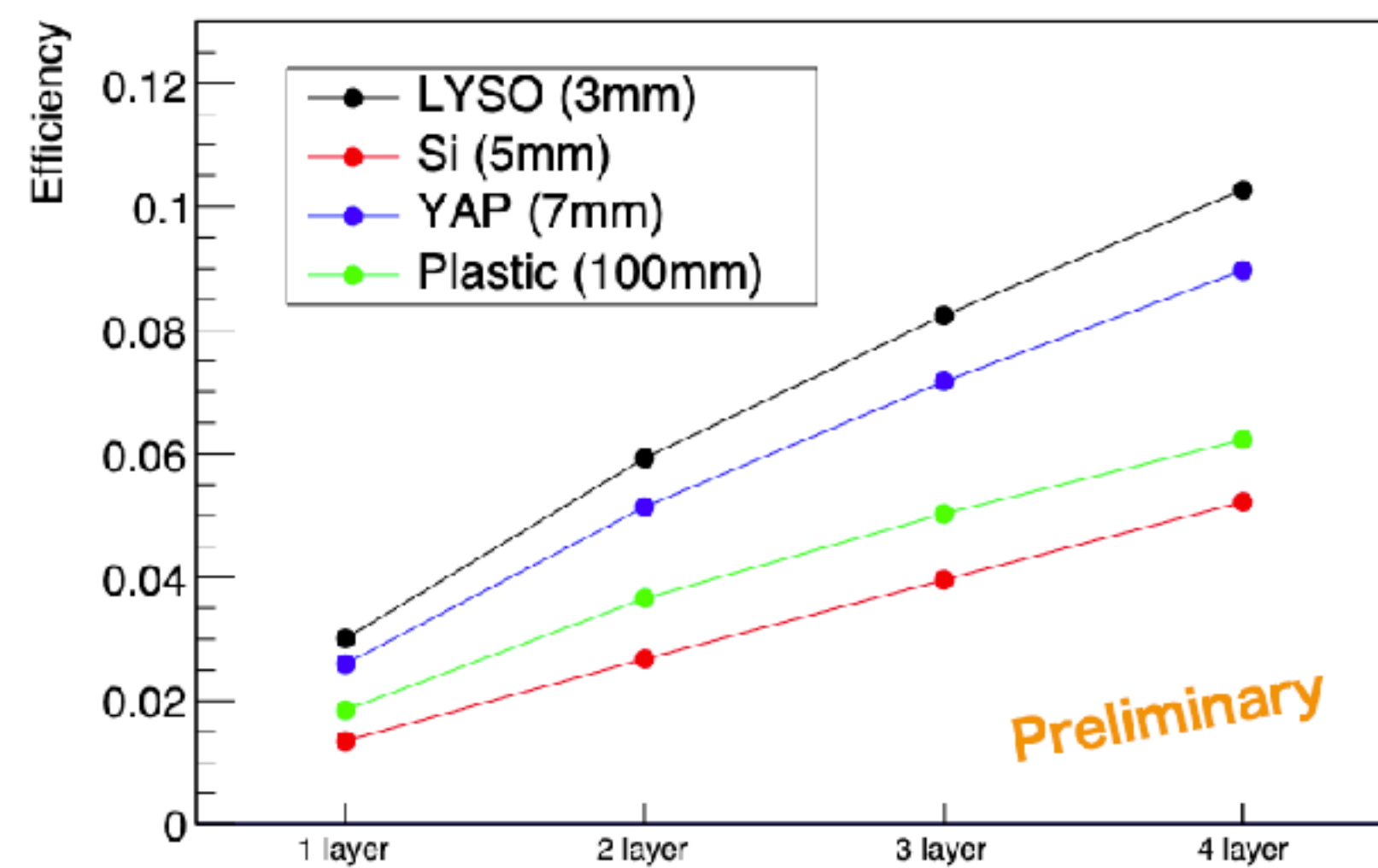
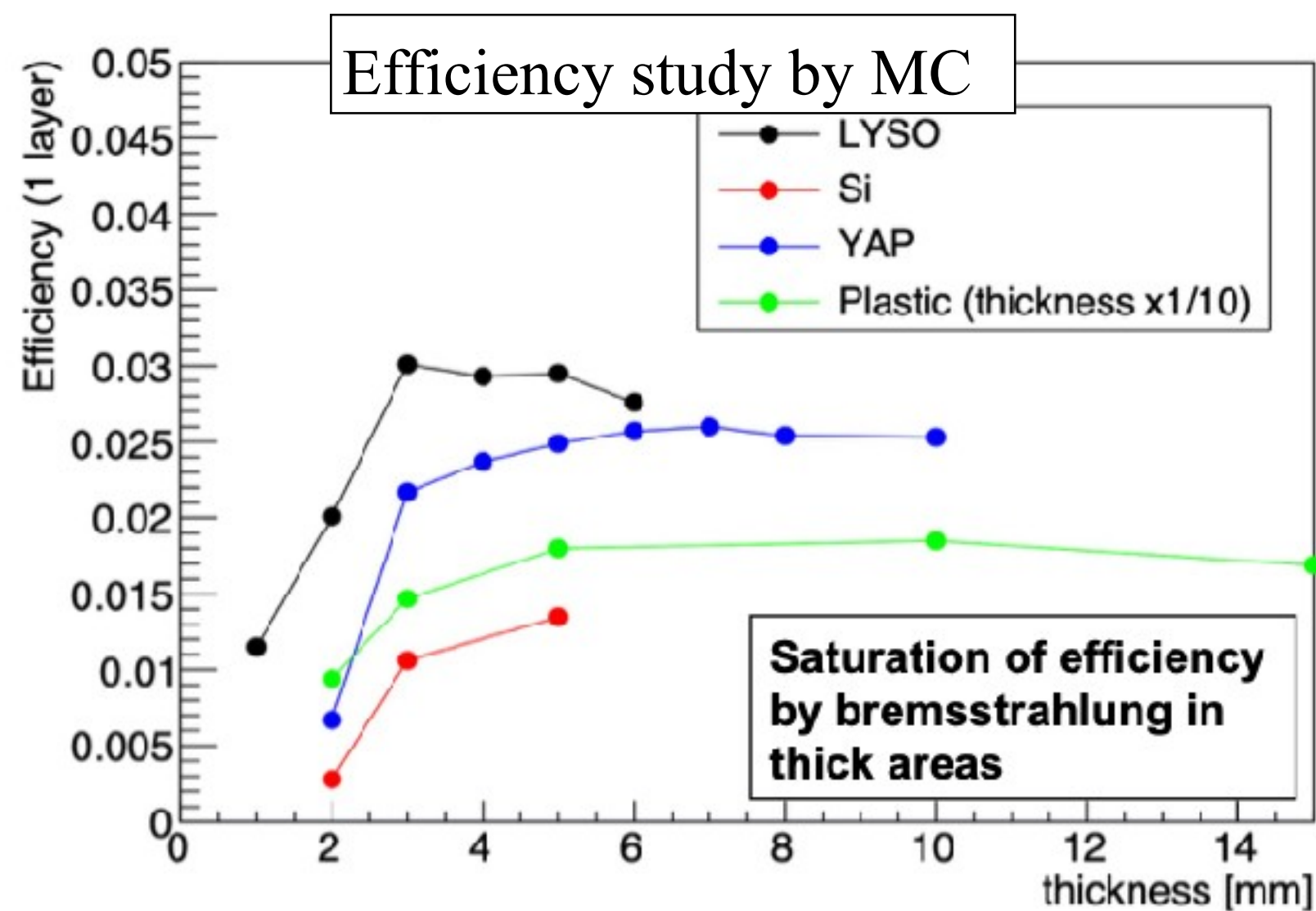
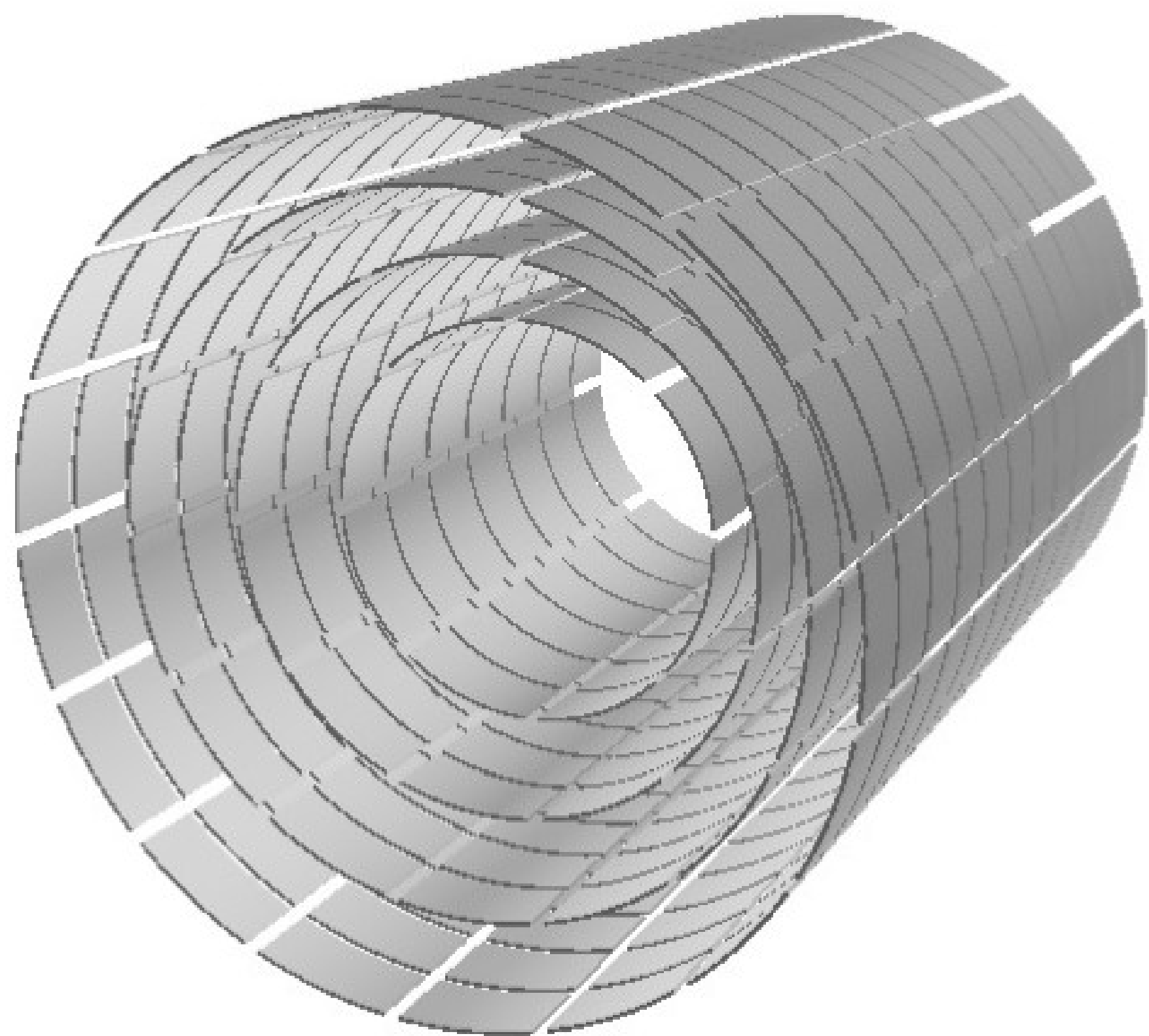

# Active converter prototype beam test in Japan

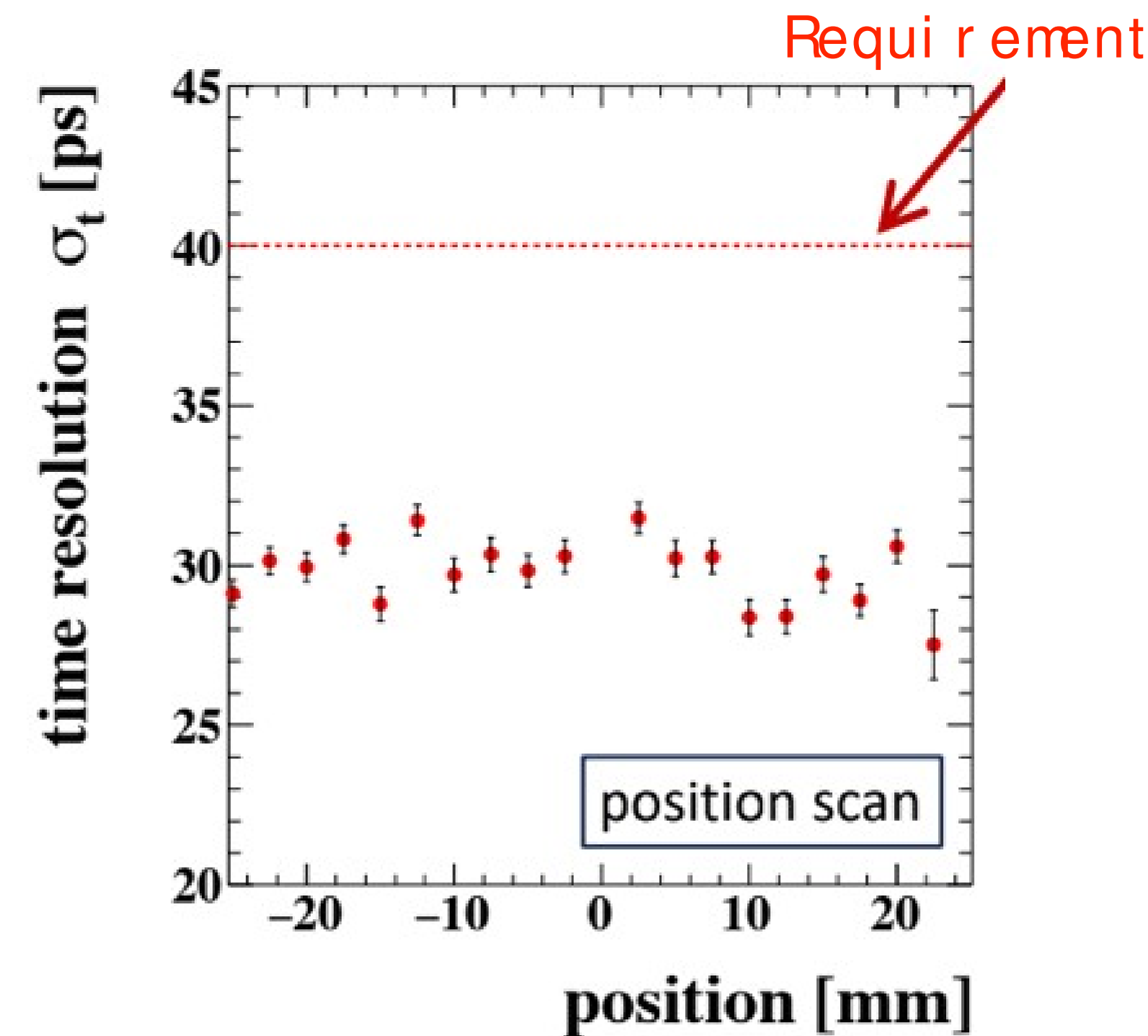
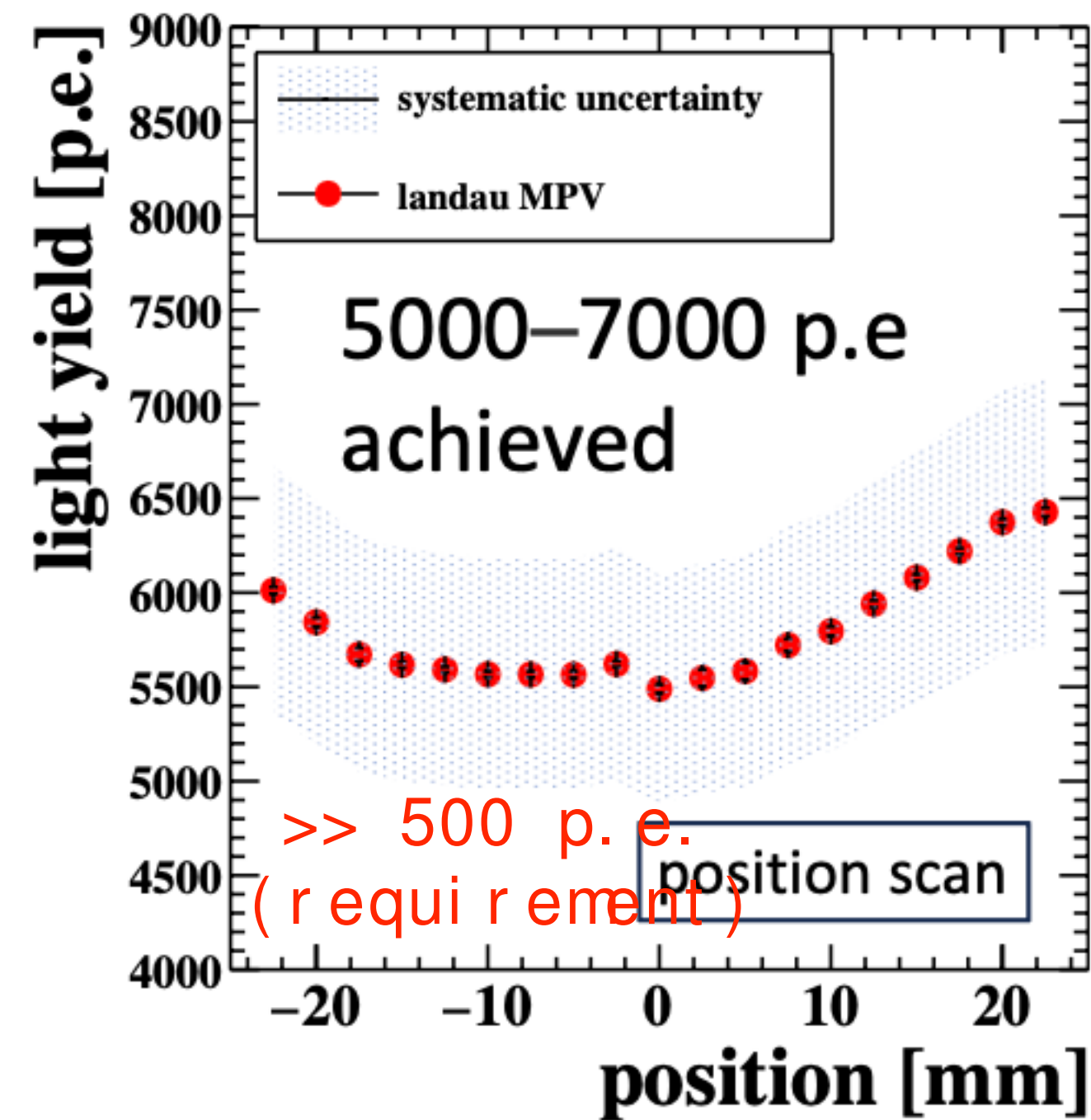
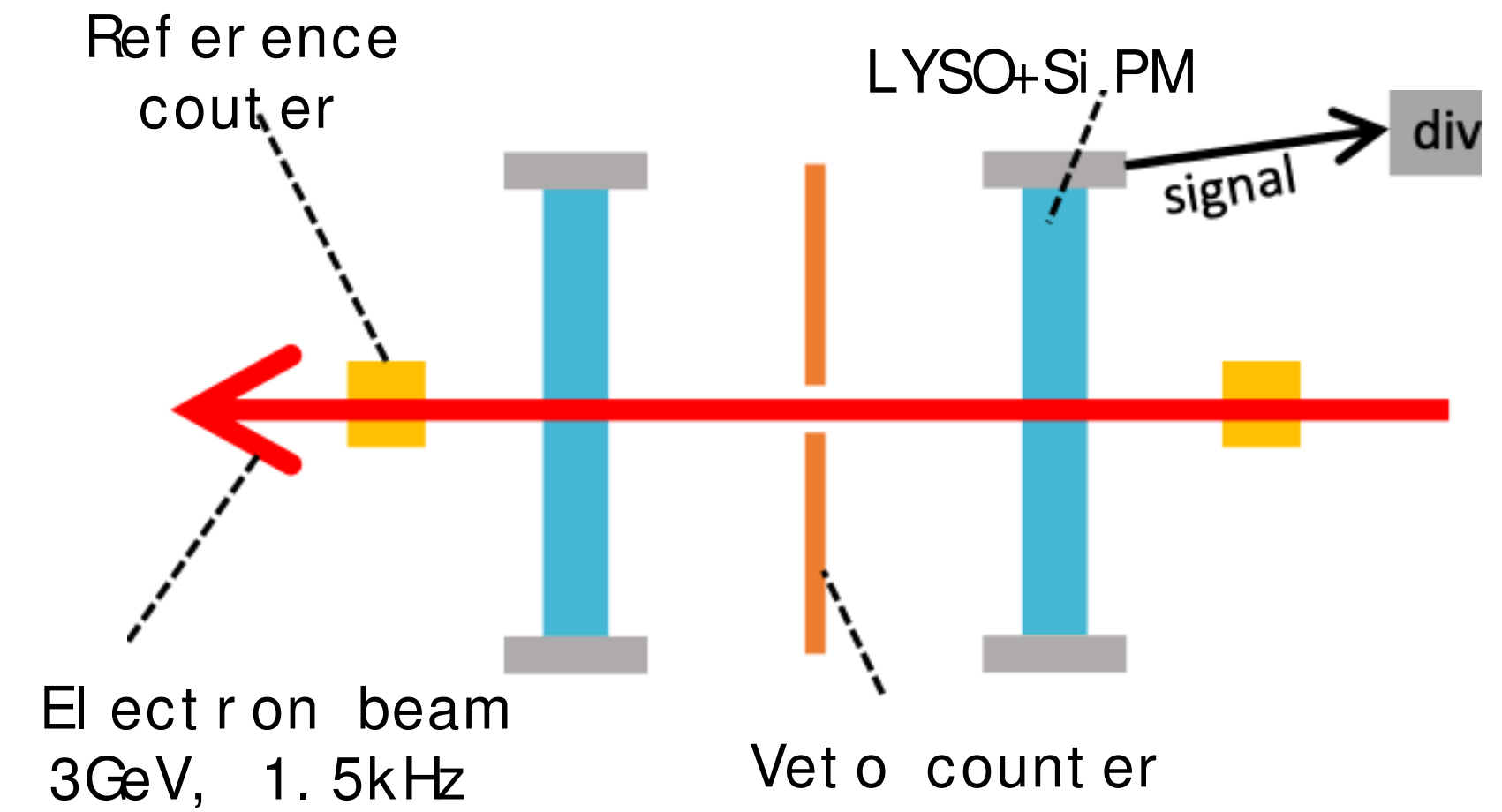
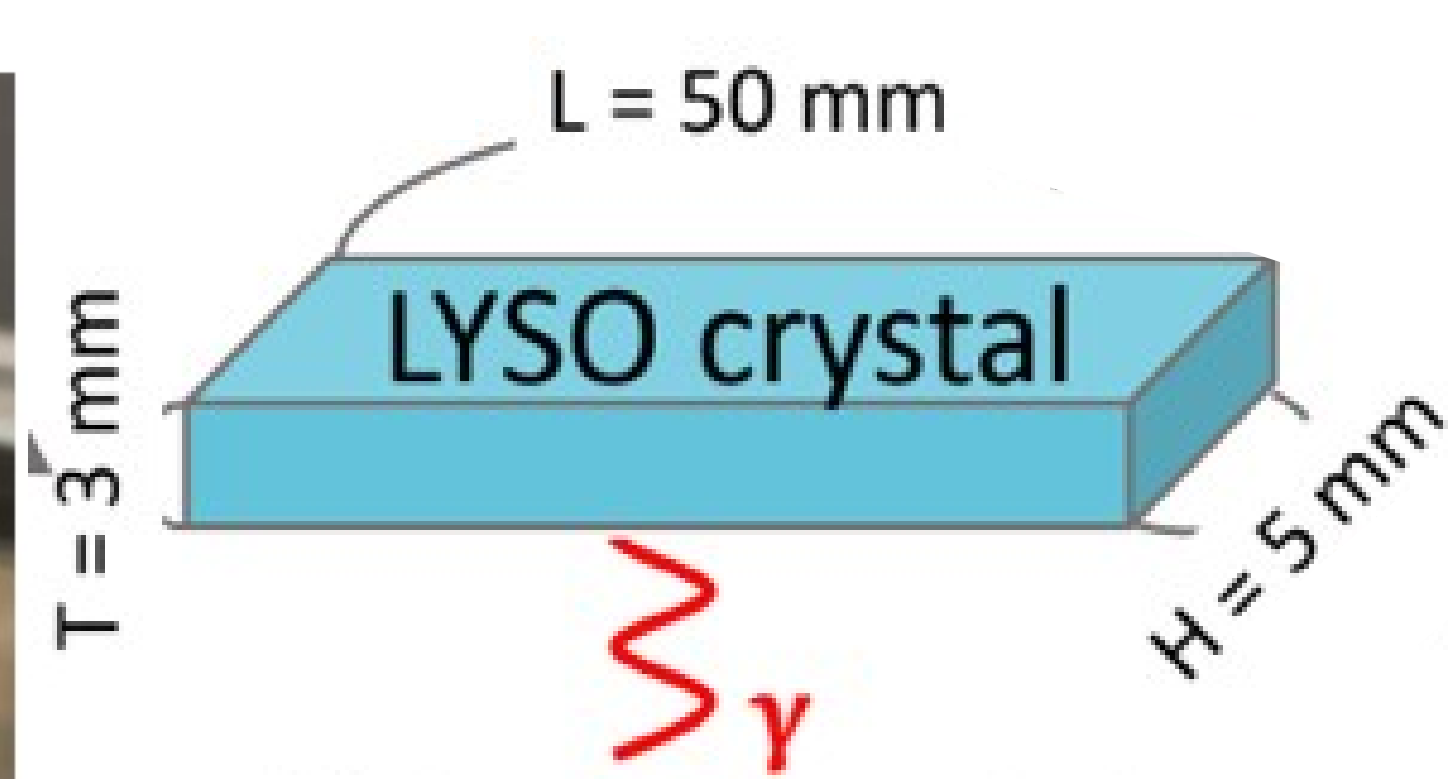
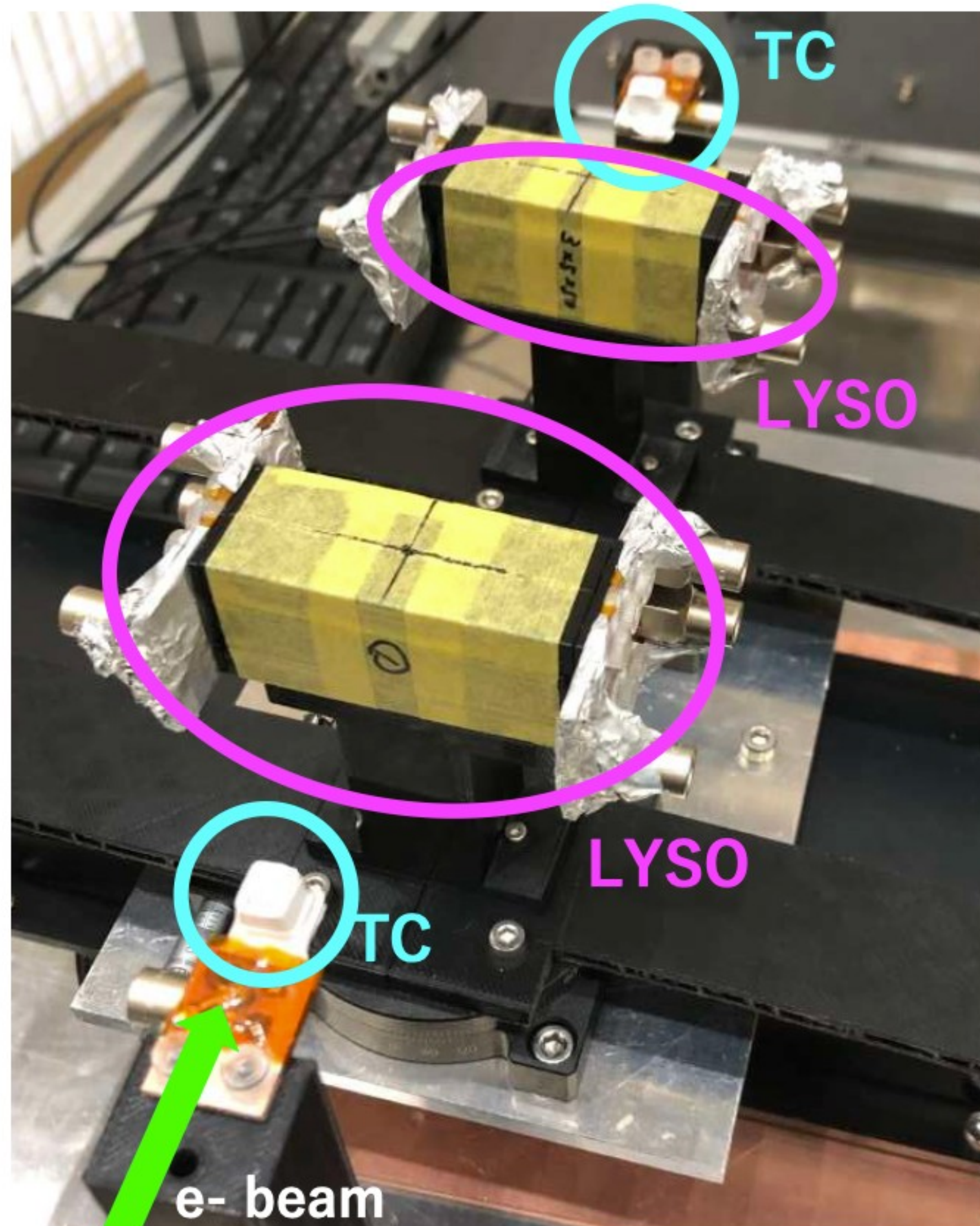

# $e^+e^-$ tracker for reconstruction of converted photons

- Silicon tracker
  - Satisfies the performance requirements
  - $O(10 \text{ m}^2/\text{conv. layer}) \rightarrow$  expensive, many channels
- Drift chamber
  - stereo geometry needed  $\rightarrow$  acceptance limited
  - granularity limited by cell size  $\rightarrow$  difficult for low  $p$
- Time projection chamber
  - overcomes limitations of a drift chamber
  - requires a light gas mixture
  - Drift cannot be along beam  $\rightarrow$  radial TPC
  - Limited space for readout electronics
  - TPC strip readout demonstrator test @ beam

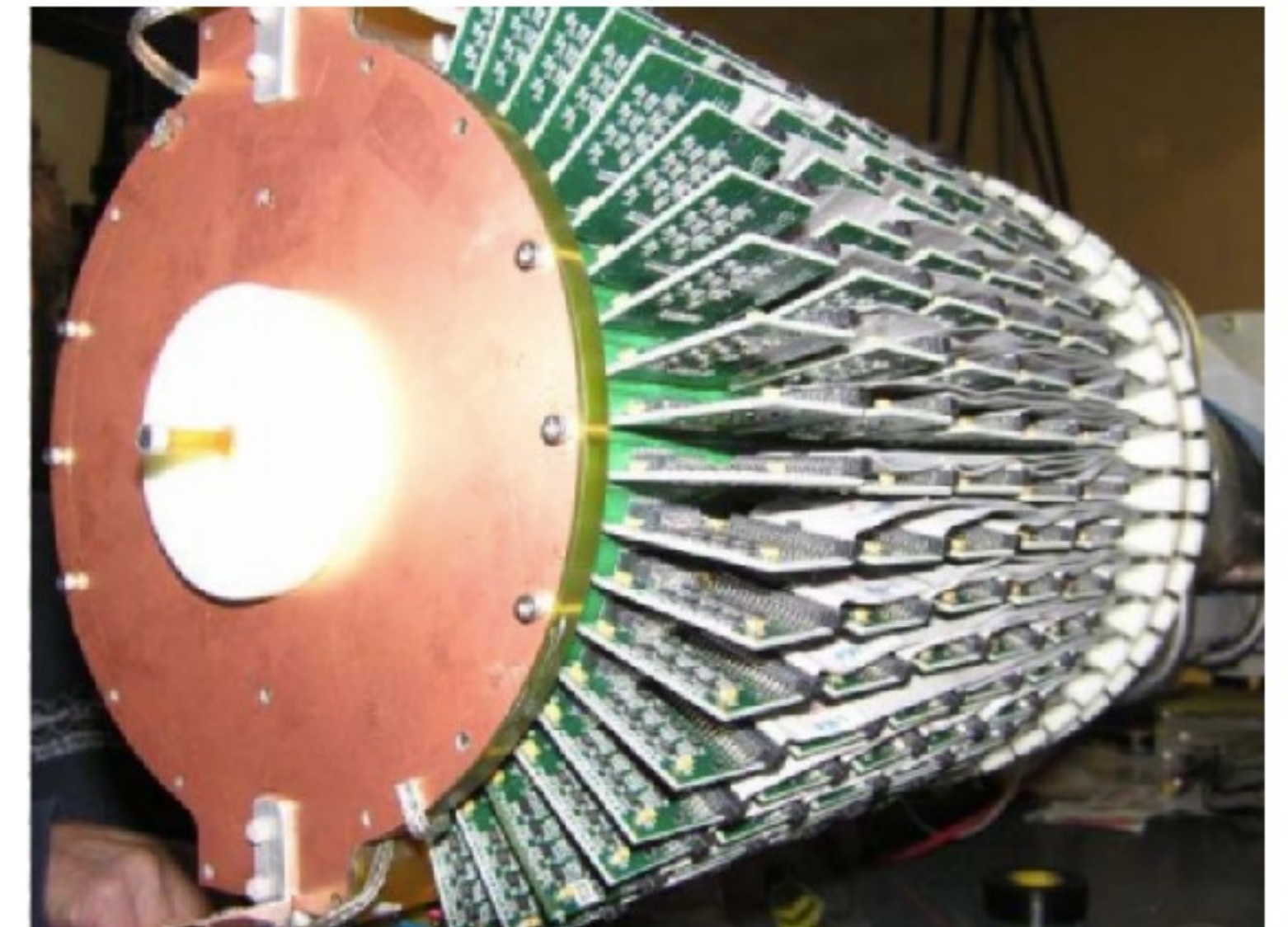
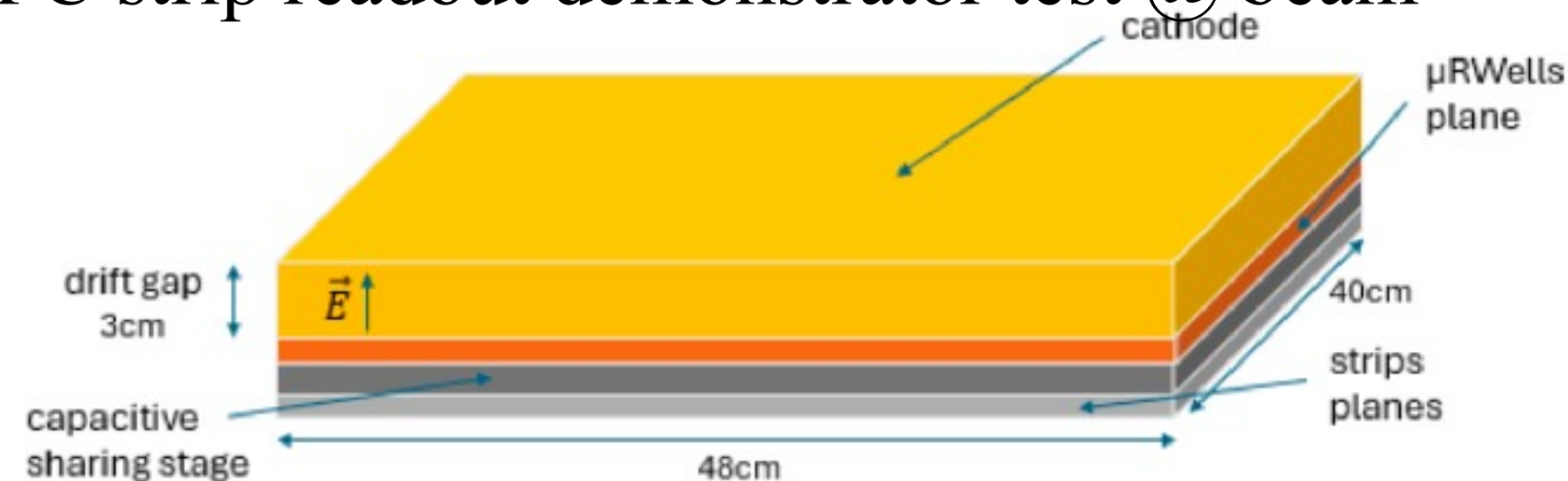

BONuS radial TPC @ J-LAB

# Tracker for positrons

- Cylindrical Drift Chamber
  - Exploiting the existing MEGII backup CDCH
  - Beam rate up to few  $10^8 \mu/s$  to be verified
- Radial Time Projection Chamber
  - Stand higher rate than drift chamber
  - Requires a light gas mixture
  - Drift cannot be along beam  $\rightarrow$  radial TPC
  - Common R&D with converter tracker
- Silicon tracker
  - Satisfies the performance requirements: multiple scattering?
  - Expensive, many channels, requires thin pixels
  - Exploits Mu3e tracker R&D

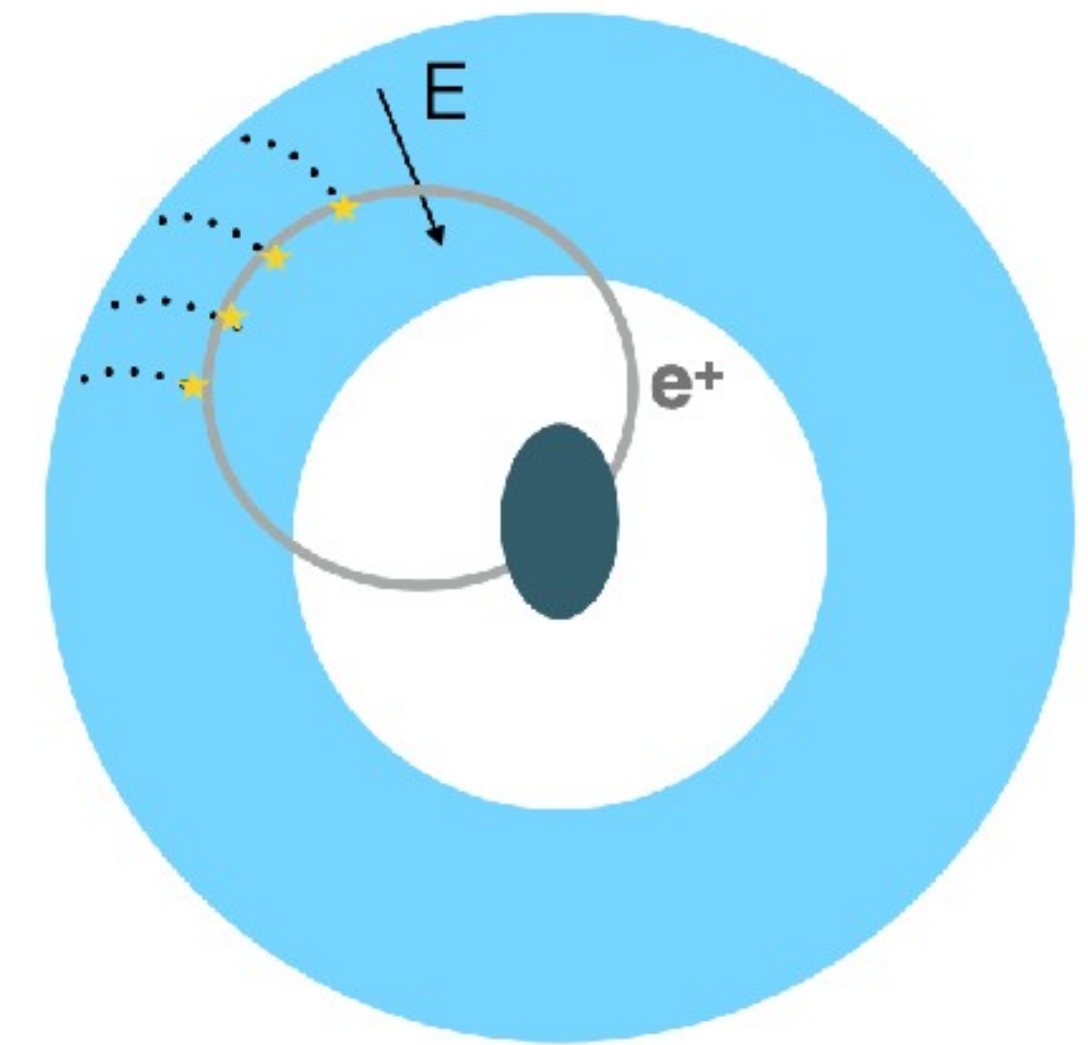
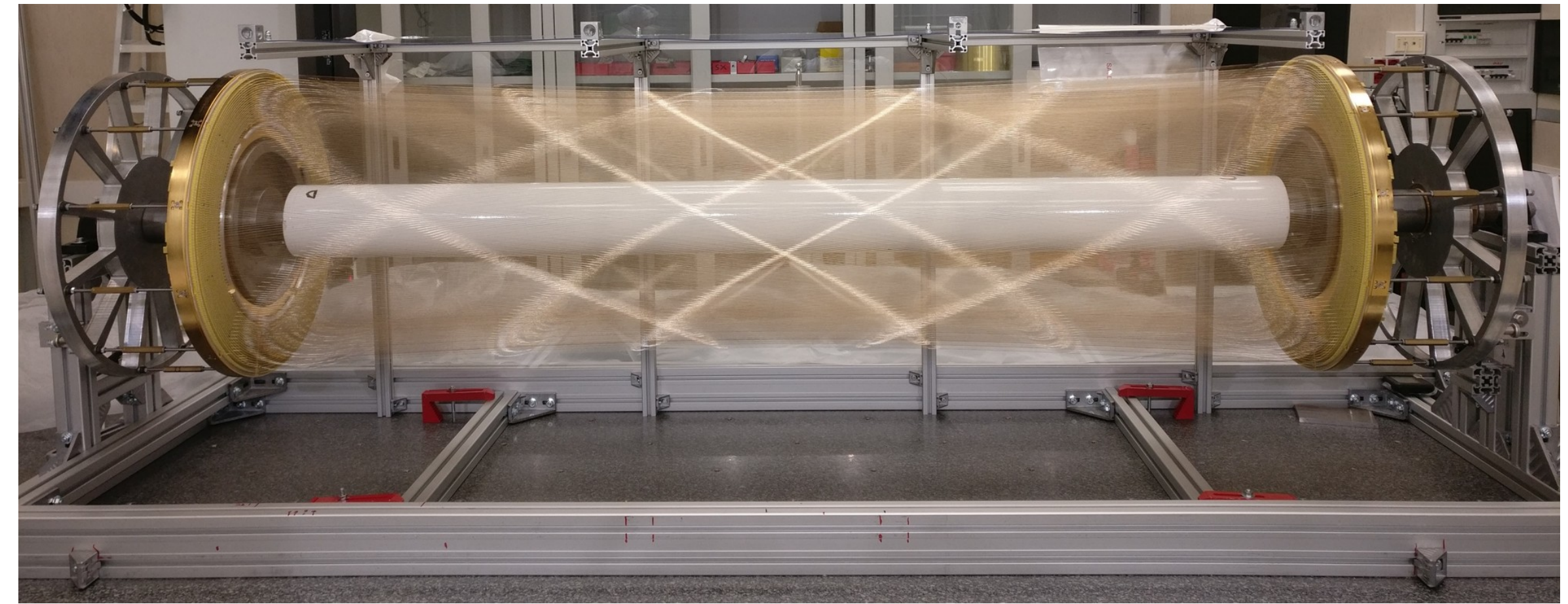

# Future $\mu^+ \rightarrow e^+ \gamma$ Schedule

- Staged approach
- Phase-I
  - Proof of principle of the conversion technique
    - CEX 55MeV  $\gamma$  with converter+tracker in COBRA
  - Running at a few  $10^8 \mu^+$ /s, sensitivity of a few  $10^{-14}$  (possible in PiE5) with COBRA and CDCH from MEGII
- Phase-II
  - New silicon positron tracker
  - Construction after the completion of Mu3e at HIMB
  - Experiment in the second half of the next decade

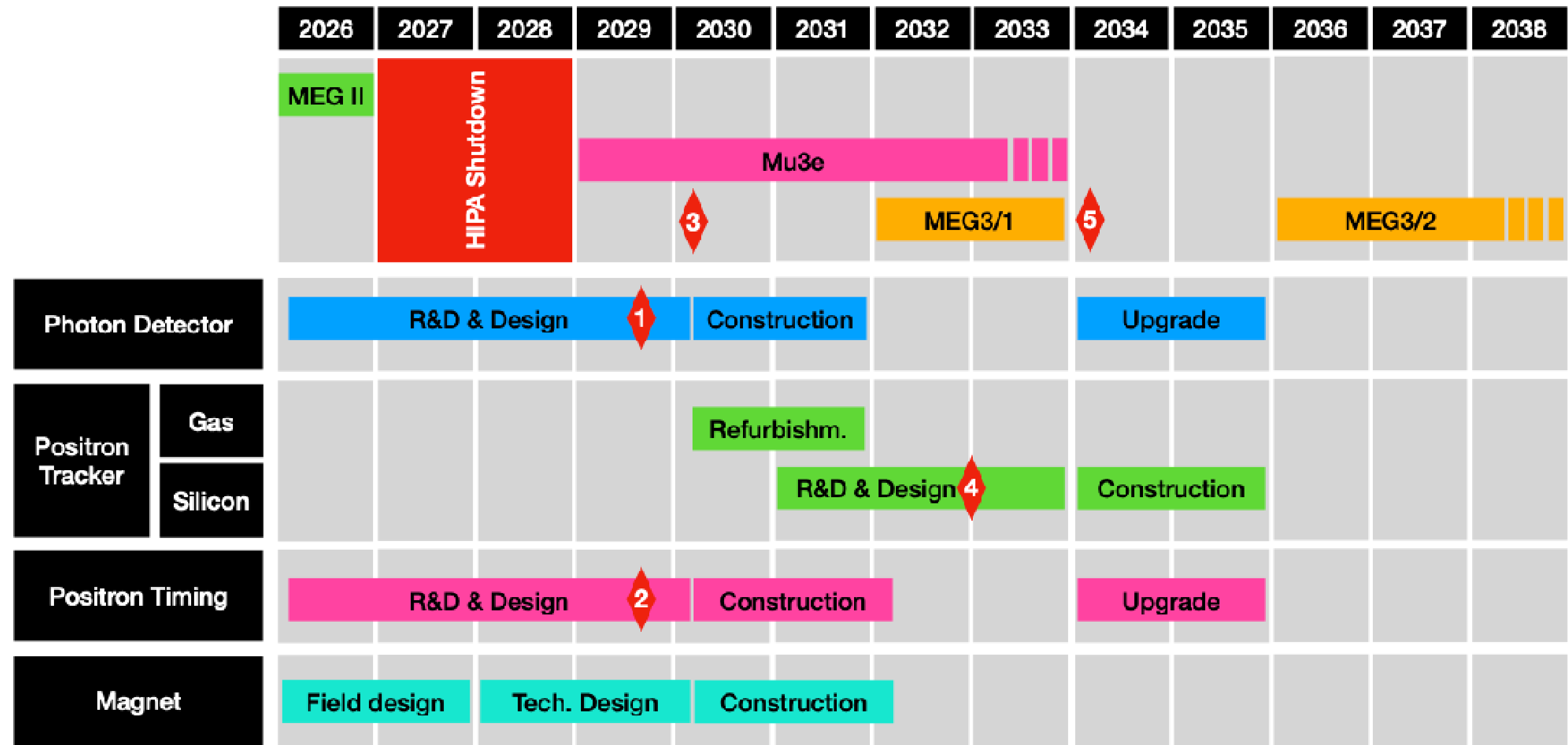

- ◆ 1: Photon converter proof of principle (CEX with converter + tracker in the MEG COBRA magnet)
- ◆ 2: Decision about positron timing technology
- ◆ 3: phase-I approval by PSI and funding agencies
- ◆ 4: Decision about positron tracker technology for phase-II
- ◆ 5: phase-II approval by PSI and funding agencies

# Sensitivity for future

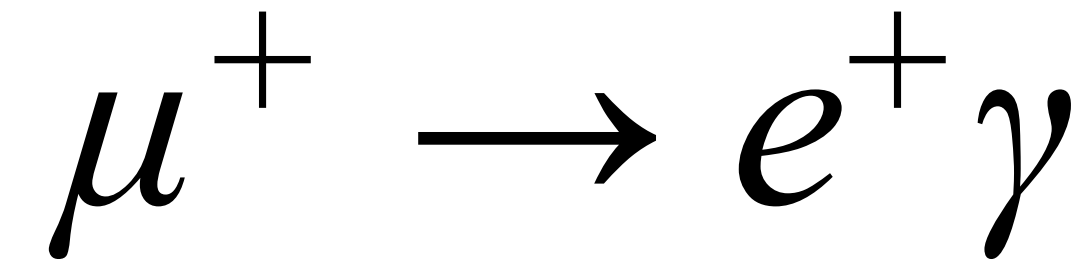

- Assumption
  - Five separate stopping targets
  - Detector performance in a table below
- $(2-3) \times 10^{-15}$  are reachable above  $10^9 \mu^+/_s$

	Resolutions/efficiencies		MEG II
Photon energy	200 keV	0.4%	2%
Photon position	200 $\mu\text{m}$		2.5mm
Photon timing	30 ps		65ps
Photon angle	150 mrad		—
Photon detection efficiency (4 layers)	6 %		62%
Positron energy	100 keV		100 keV
Positron angle	6 mrad		6 mrad
Positron timing	30 ps		30 ps
Positron detection efficiency	70 %		67%
Geometrical acceptance	85 %		11%

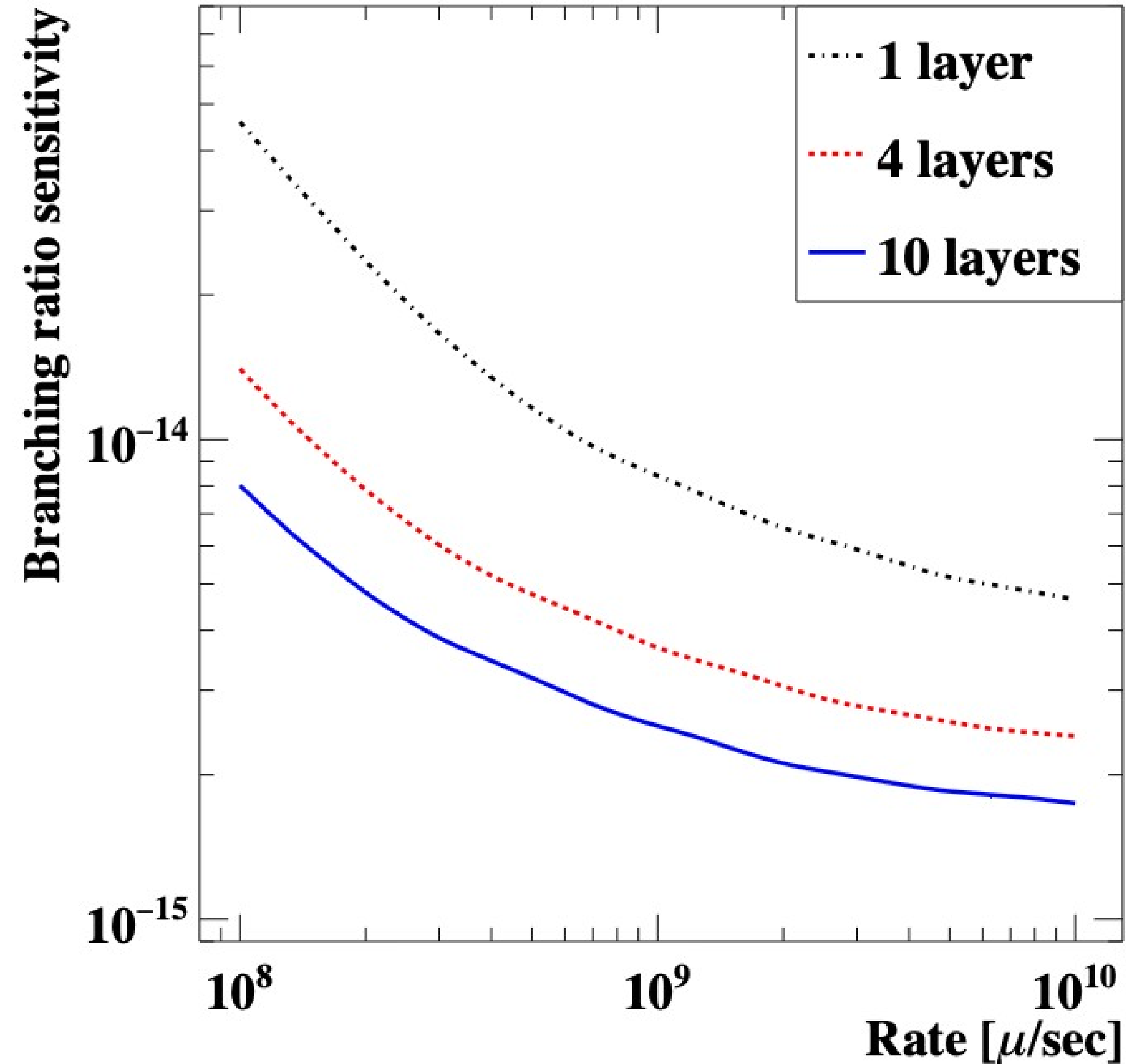

# cLFV search prospects

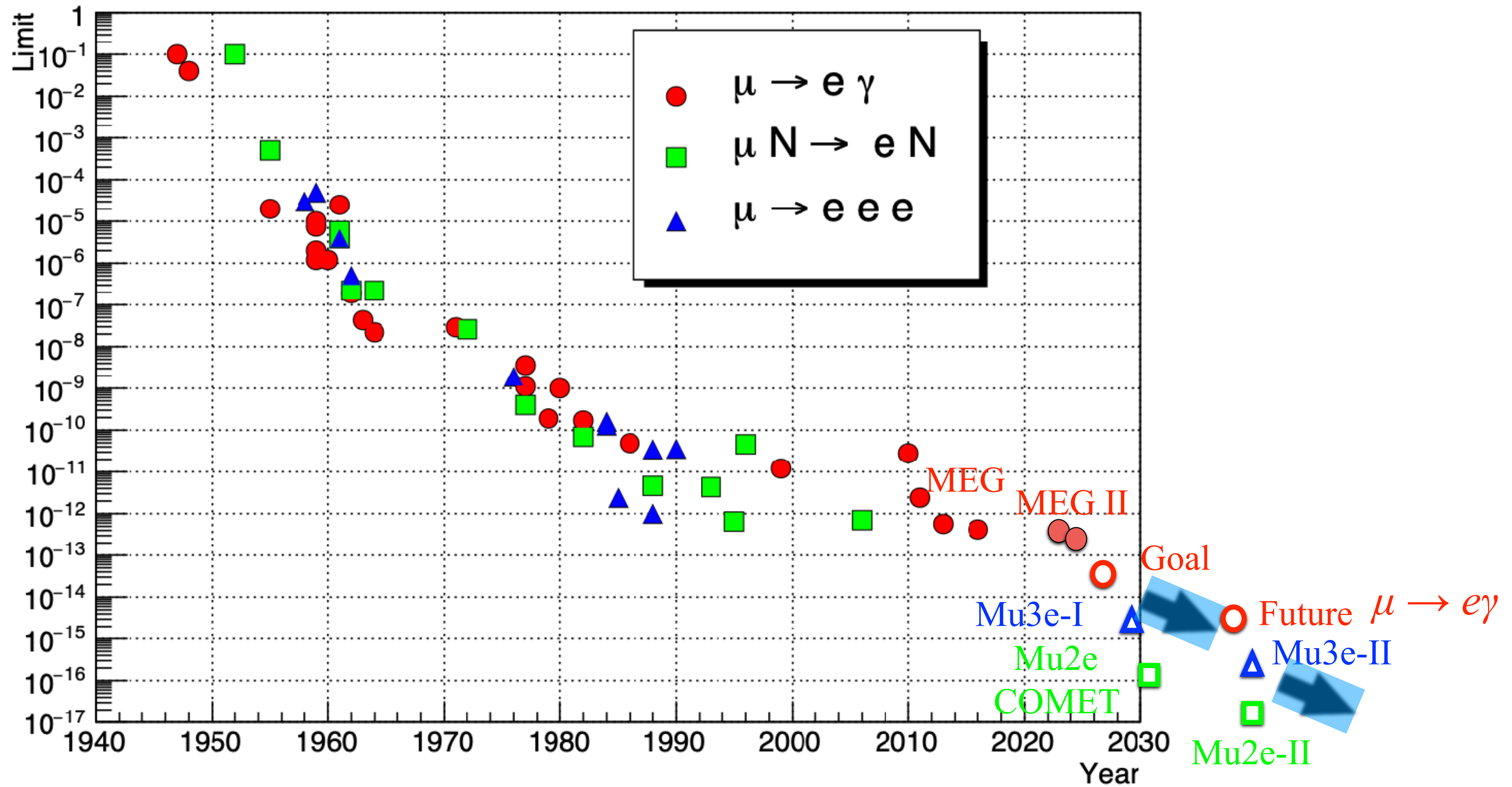

# Summary

- CLFV experiments are one of the most powerful probe to search for new physics, and the golden channels ( $\mu^+ \rightarrow e^+ \gamma, \mu \rightarrow e^+ e^- e^+, \mu^- \rightarrow e^-$ ) can be complementary in searching for and pinning down the new physics
- MEG II experiment is the running experiment. Mu3e, COMET phase-I, and Mu2e Run1 will start soon, and new results will be available in the next years.
- Muon beam intensity improvements up  $10^{10} \mu/s$  are underway.
- The development of experimental apparatus must match the future accelerator high intensity to achieve the highest possible sensitivity.
- A staged approach to  $\mu^+ \rightarrow e^+$  with beam intensity a few  $10^8 \mu/s$  relying on MEG COBRA magnet and CDCH as first stage is under study.

# MEG II

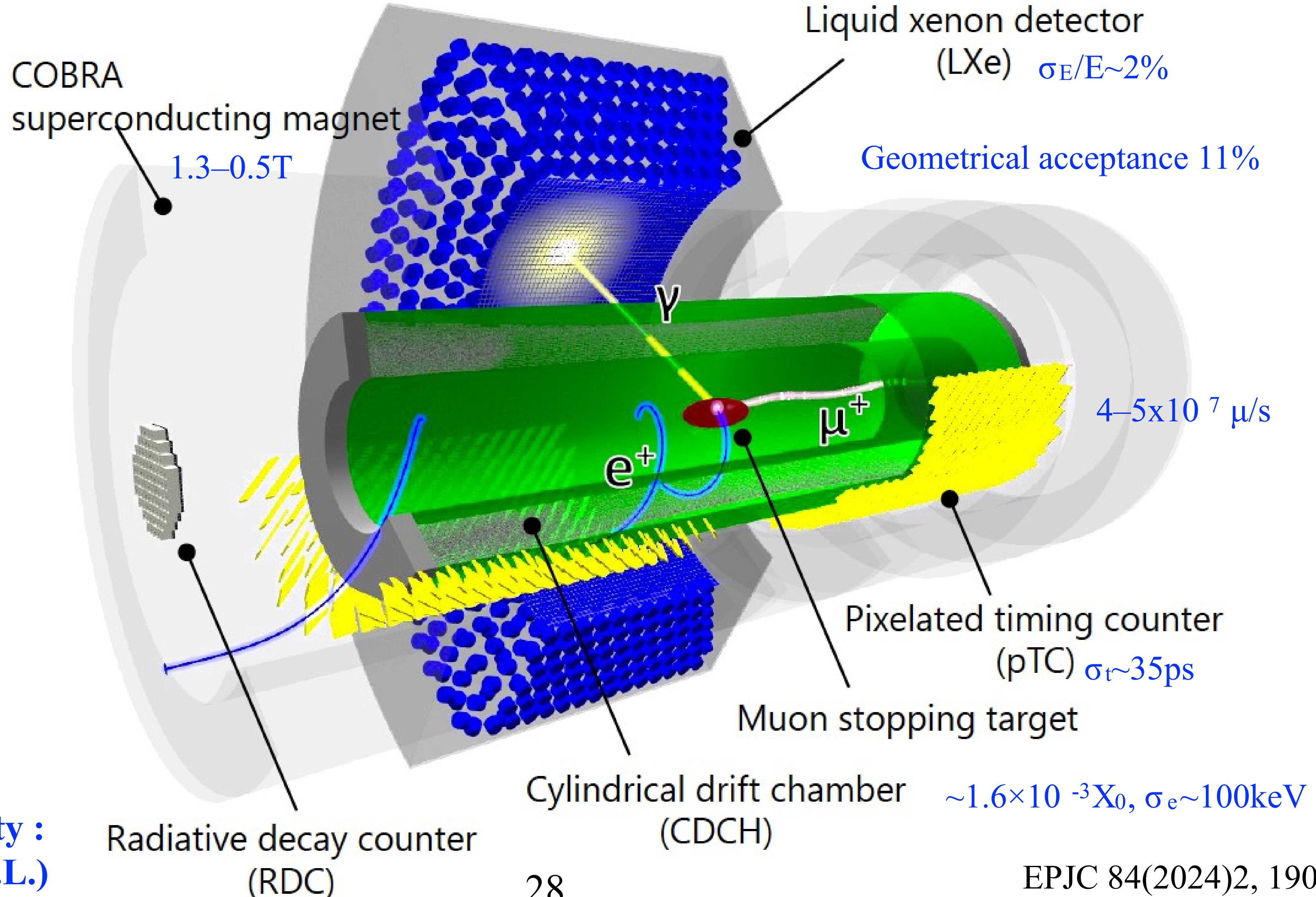

**Target sensitivity :**  
 $6 \times 10^{-14}$  (90% C.L.)

# Detector performance summary

**Table 6** Resolutions (Gaussian  $\sigma$ ) and efficiencies measured at  $R_\mu = 4 \times 10^7 \text{ s}^{-1}$ , compared with the predictions from [3, 57].

<b>Resolutions</b>	Foreseen	Achieved	<b>MEG</b>
$E_{e^+}$ (keV)	100	89	<b>320</b>
$\phi_{e^+}^{\text{a)}$ , $\theta_{e^+}$ (mrad)	3.7/6.7	4.1/7.2	<b>9.4</b>
$y_{e^+}$ , $z_{e^+}$ (mm)	0.7/1.6	0.74/2.0	
$E_\gamma(\%)$ ( $w < 2 \text{ cm}$ )/( $w > 2 \text{ cm}$ )	1.7/1.7	2.0/1.8	<b>2.4 / 1.7</b>
$u_\gamma$ , $v_\gamma$ , $w_\gamma$ (mm)	2.4/2.4/5.0	2.5/2.5/5.0	<b>5 / 5 / 6</b>
$t_{e^+\gamma}$ (ps)	70	78	<b>122</b>
<b>Efficiency (%)</b>			
$\mathcal{E}_\gamma$	69	62	<b>63</b>
$\mathcal{E}_{e^+}$	65	67	<b>30</b>
$\mathcal{E}_{\text{TRG}}$	$\approx 99$	80	<b>99</b>

# MEG II data taking so far

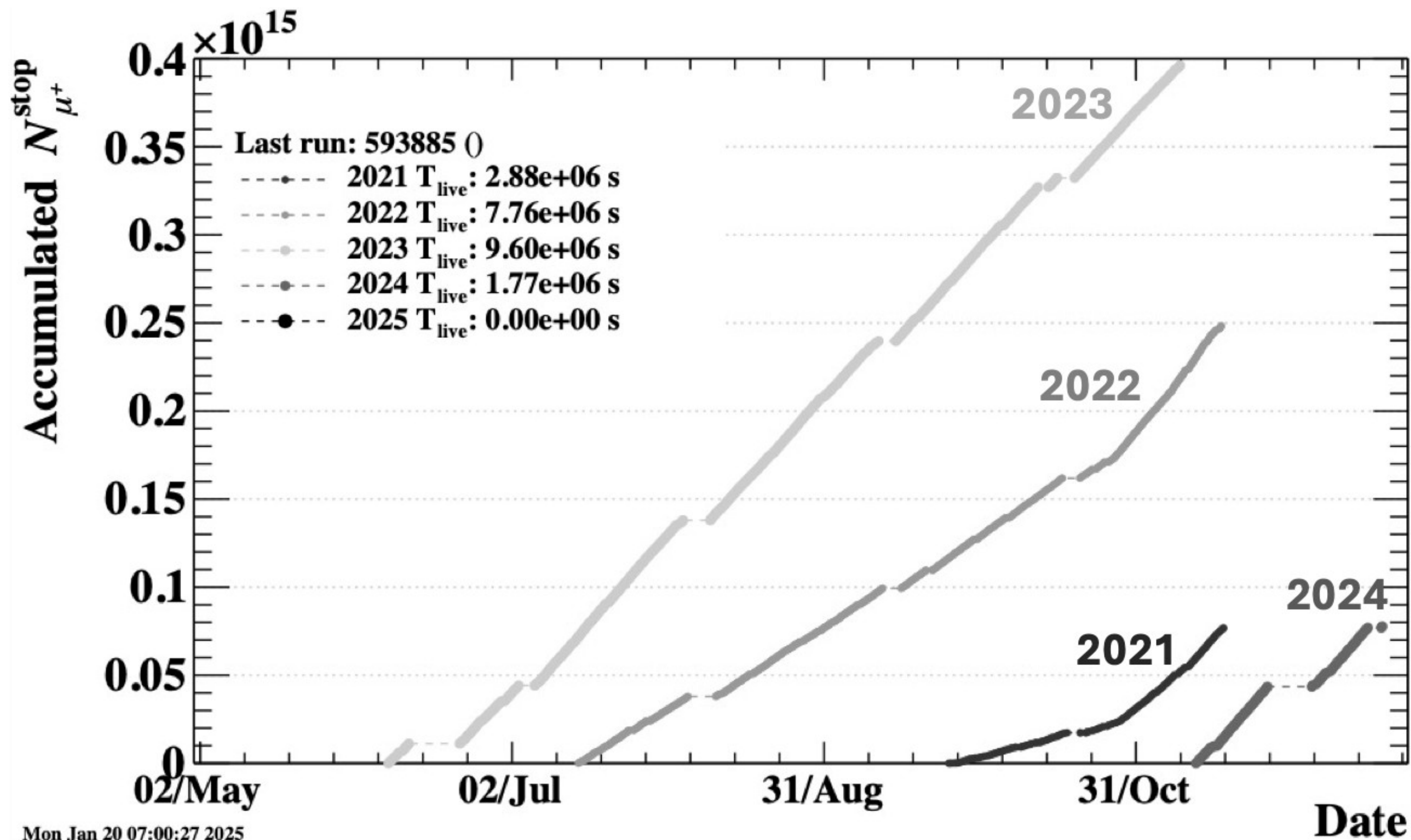

MEG II total statistics  
 $8.1 \times 10^{14} \mu$  stops  
 $\sim \times 10$  the 2021 published statistics

# Method of $\mu \rightarrow e\gamma$ search

- Blind analysis
  - Time coincidence  $t_{e+\gamma}$  within 1ns,  $48\text{MeV} < E_\gamma < 58\text{MeV}$
- Sideband to extract PDFs, analysis check
  - Four time sidebands for  $N_{\text{ACC}}$  study
  - low energy sideband for  $N_{\text{RMD}}$  study
- Maximum likelihood analysis to estimate  $N_{\text{sig}}$ 
  - Confidence interval from Feldman-Cousins method

$$\mathcal{L}(N_{\text{sig}}, \overbrace{N_{\text{RMD}}, N_{\text{ACC}}}^{\text{nuisance parameters}}, x_{\text{T}}) = \frac{e^{-(N_{\text{sig}} + N_{\text{RMD}} + N_{\text{ACC}})}}{N_{\text{obs}}!} \underbrace{C(N_{\text{RMD}}, N_{\text{ACC}}, x_{\text{T}})}_{\text{constrained by sideband}} \times \prod_{i=1}^{N_{\text{obs}}} (N_{\text{sig}} \underbrace{S(\vec{x}_i)}_{\text{per-event PDFs}} + N_{\text{RMD}} \underbrace{R(\vec{x}_i)}_{\text{per-event PDFs}} + N_{\text{ACC}} \underbrace{A(\vec{x}_i)}_{\text{per-event PDFs}})$$

$$\vec{x}_i = (E_e, E_\gamma, t_{e\gamma}, \theta_{e\gamma}, \phi_{e\gamma}, \Delta t_{\text{RDC}}, E_{\text{RDC}}, n_{\text{pTC}})$$

$x_{\text{T}}$  represents the target misalignment uncertainty

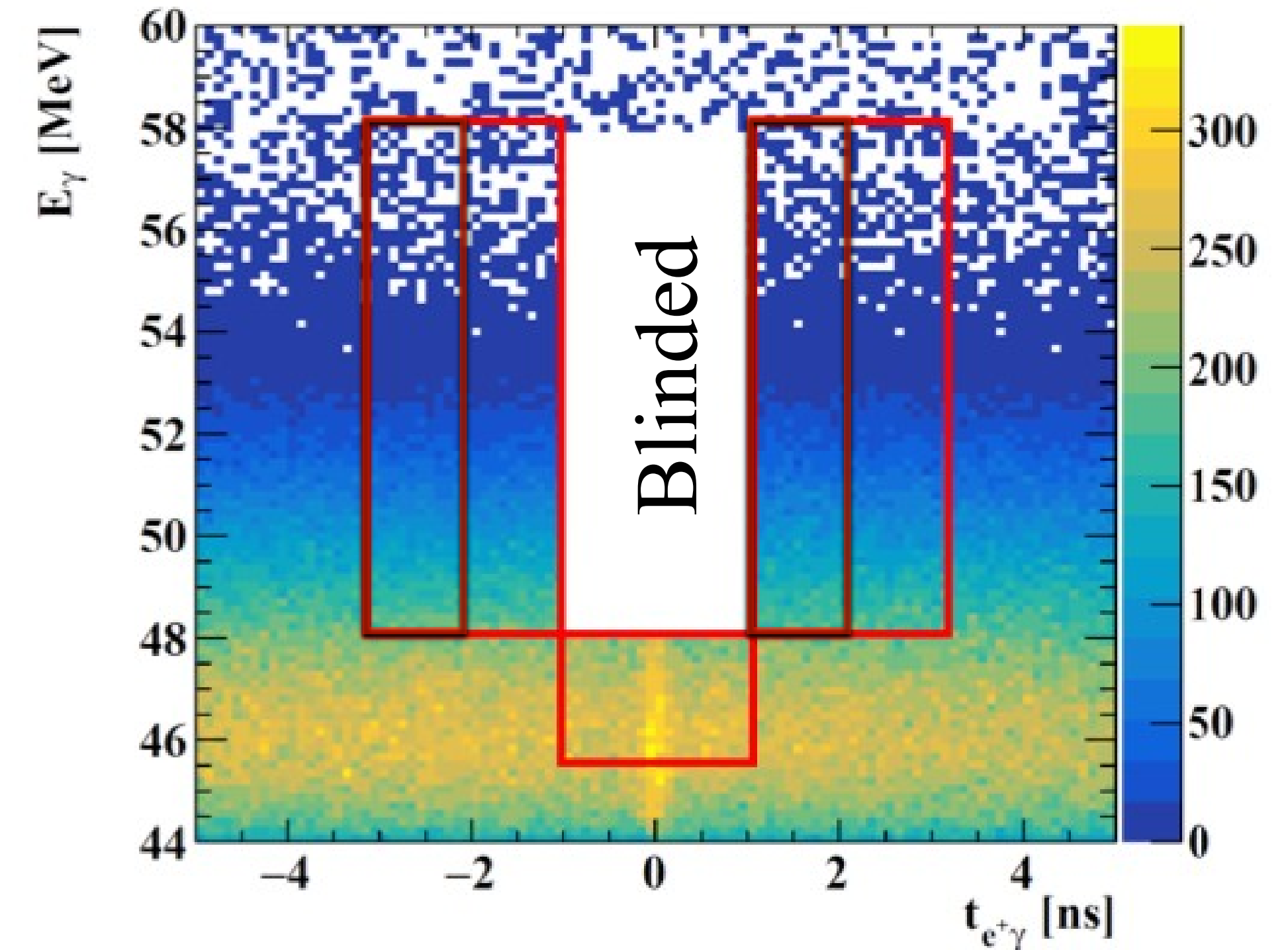

$$\begin{aligned} &\text{Analysis Region} \\ &48 < E_\gamma < 58\text{MeV} \quad 52.2 < E_{e^+} < 53.5\text{MeV} \\ &|t_{e+\gamma}| < 0.5\text{ns} \quad |\theta_{e+\gamma}| < 40\text{mrad} \quad |\phi_{e+\gamma}| < 40\text{mrad} \end{aligned}$$

# Projections of PDFs to observables (2021+2022 data set)

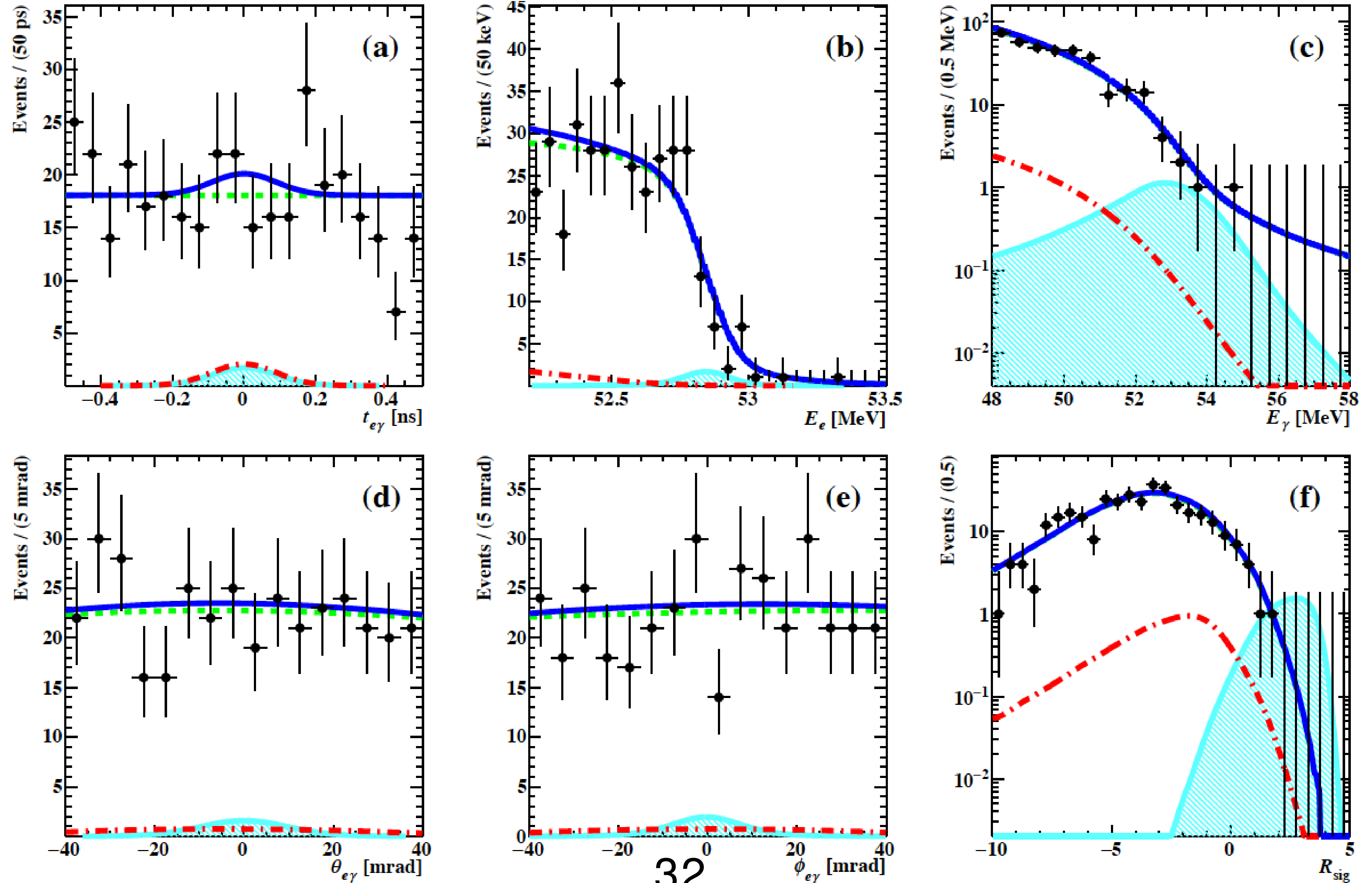

# 2-D event distributions

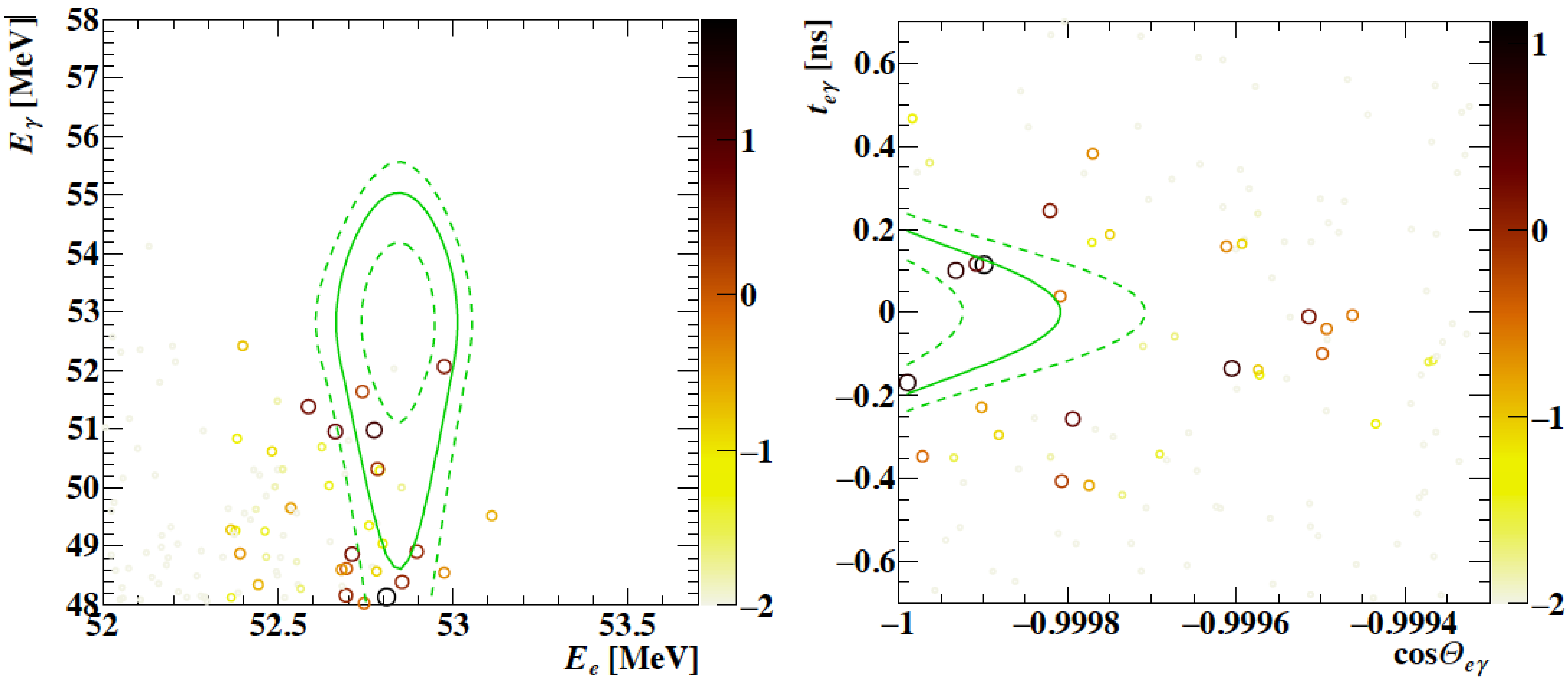

# MEG II prospects

## MEG II expected sensitivity

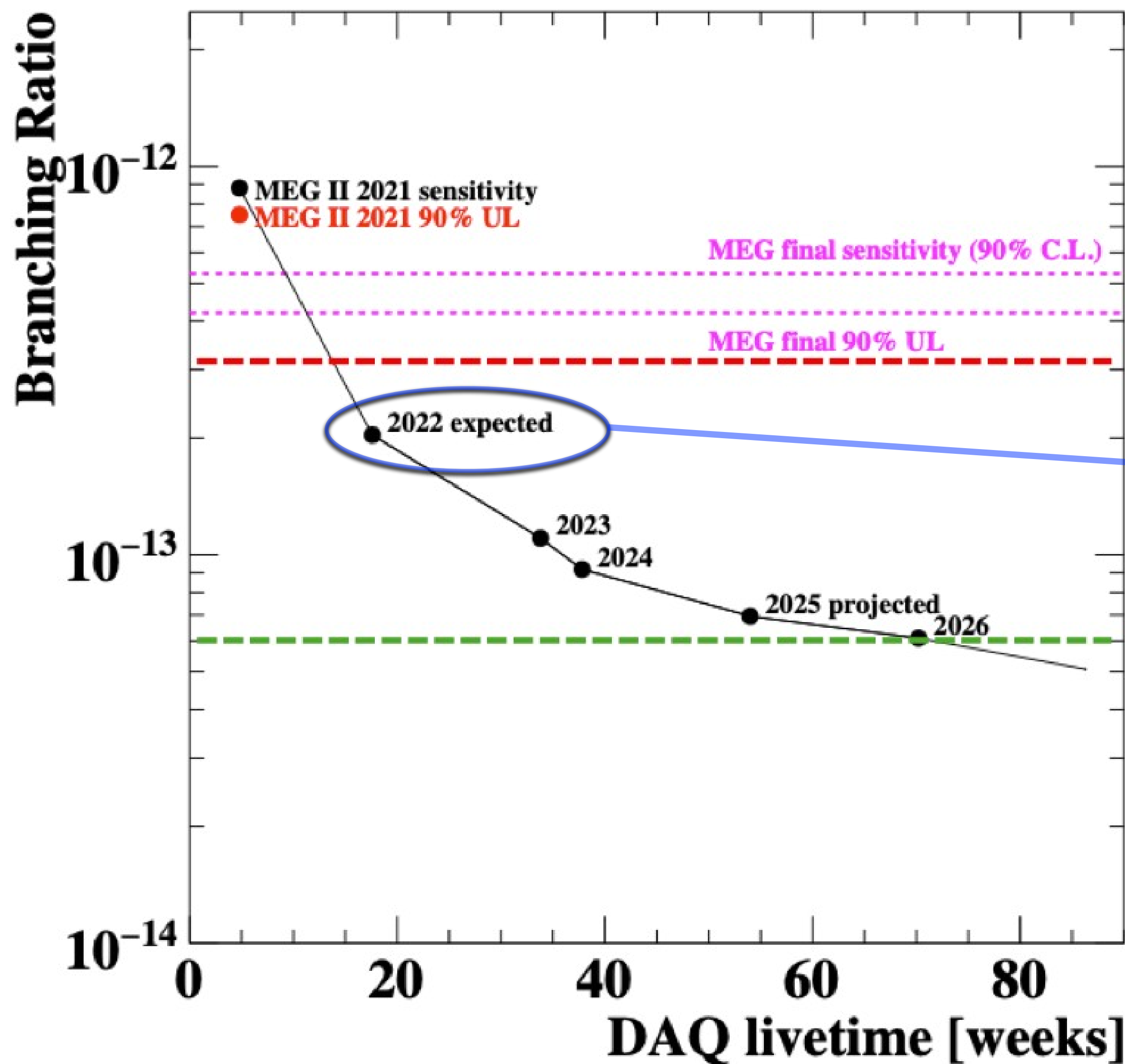

New best UL (MEG+MEG II):

$$B_{90} = 3.1 \times 10^{-13}$$

Analysis been finalized  
Results published soon

MEG II proposal goal:

$$S_{90} = 6 \times 10^{-14}$$

# Beam intensity

- Optimal beam intensity should be chosen to maximize the sensitivity
  - Statistics ( $\propto R_\mu$ )
  - Background ( $\propto R_\mu^2$ )
  - Reconstruction efficiency with pileup
  - Trigger rate & data size
  - Detector tolerance
- The current optimum intensity is  $4 \times 10^7$ /s
- Future improvements may allow higher intensity ( $5 \times 10^7$ /s)

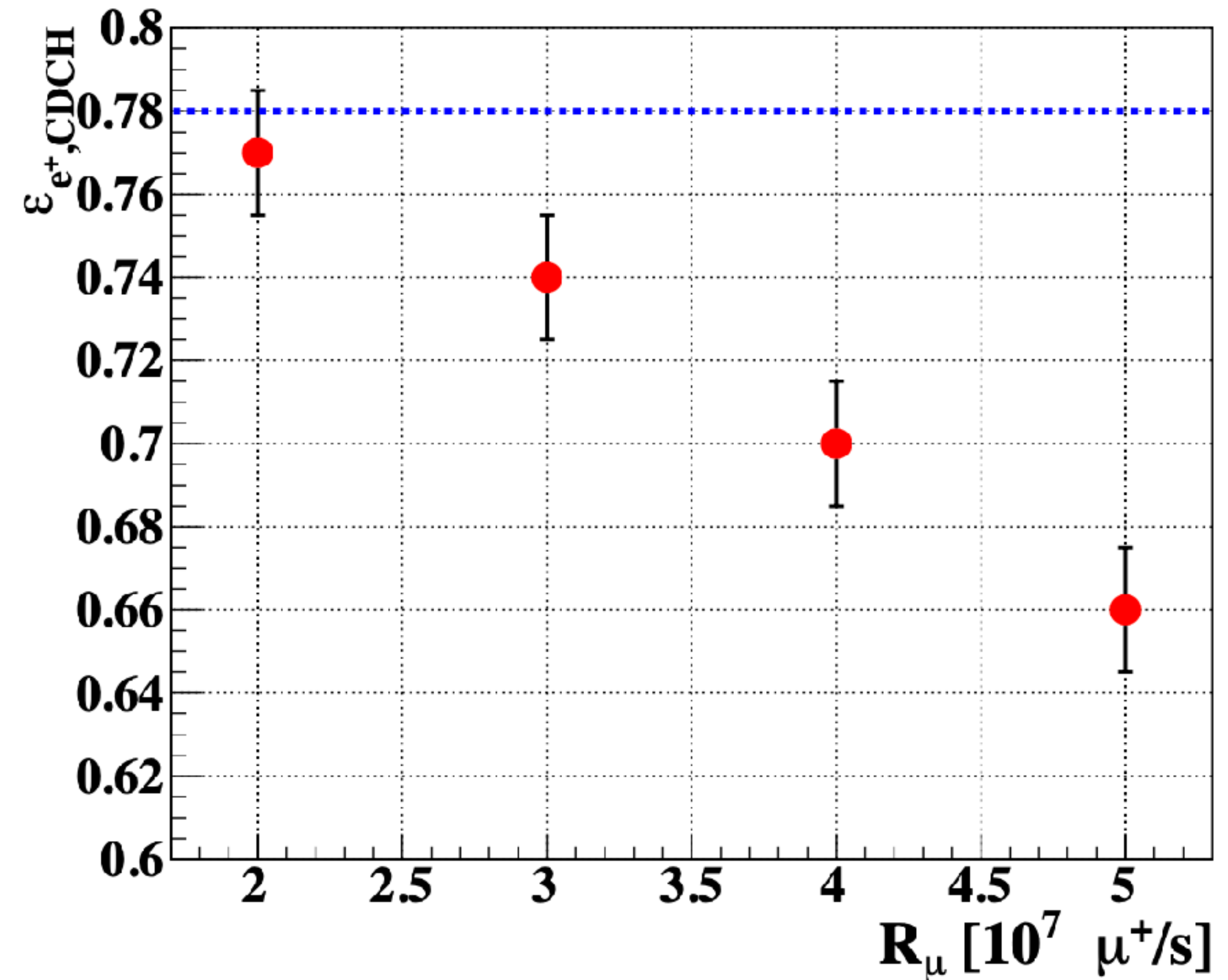

**Figure 20** CDCH tracking efficiency as a function of  $R_\mu$  for signal positrons. The blue dotted line is the design value.

# Future prospects

New experiment for  $\mu \rightarrow e\gamma$  search

- HiMB project at PSI ( $\sim 10^{10} \mu/s$ ) (2027 – 2028)
- High resolution, high rate capability for the detectors

Photon pair spectrometer with active converter

- Better resolutions, angle measurements

Silicon positron spectrometer similar with Mu3e

Separate active targets

Target sensitivity

$$\text{Br}(\mu \rightarrow e\gamma) \sim (10^{-15})$$

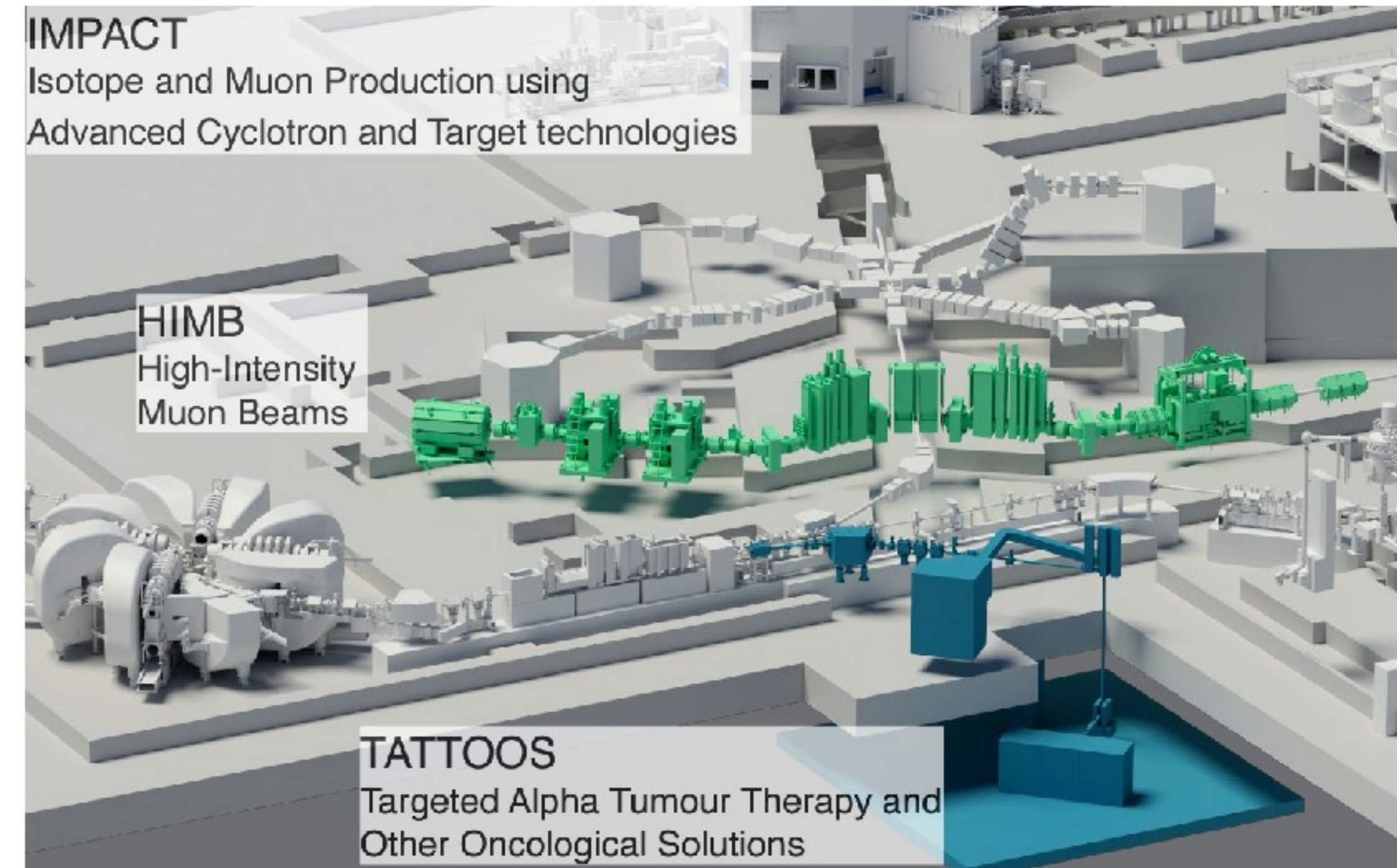
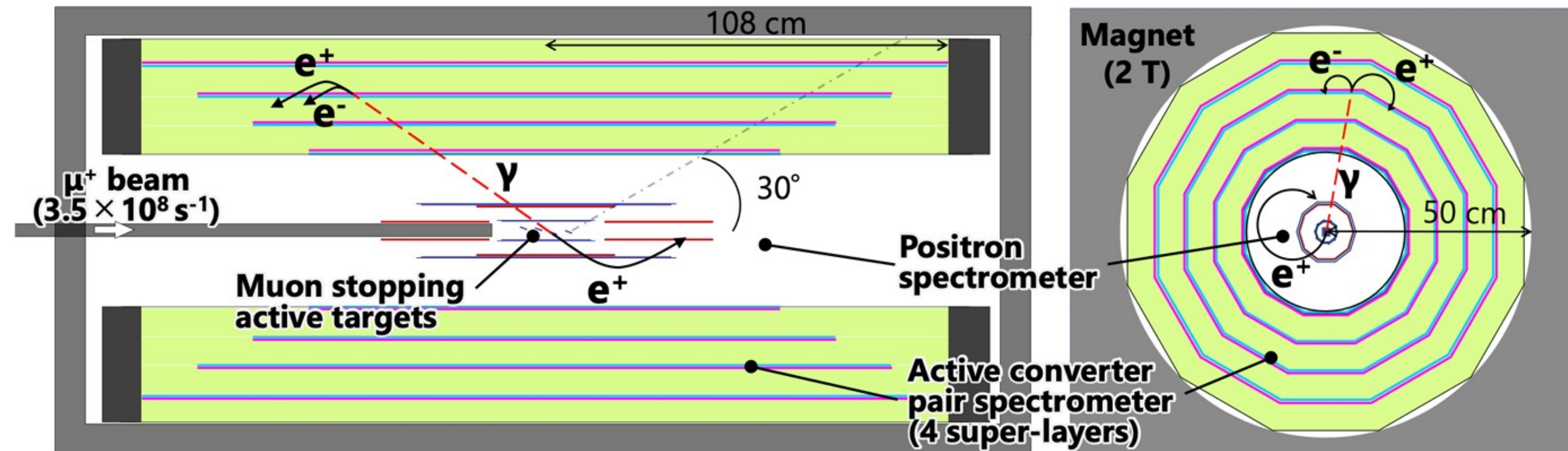

# Charged lepton flavor violation

- There are three generations (flavors), but the reason remains a mystery
- [Flavor transition in Quark and in neutrino](#) has played a decisive role in the development of particle physics
- [No observation yet for the charged lepton flavor transition](#)

## masses of matter particles

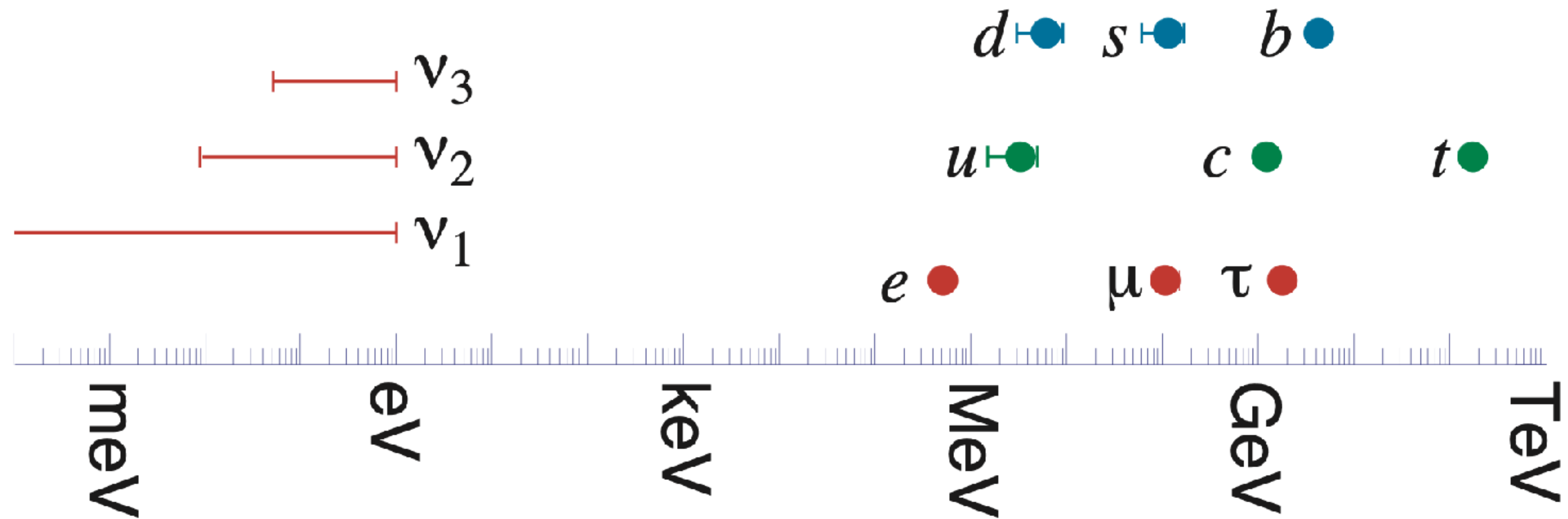

# CLFV with other indications

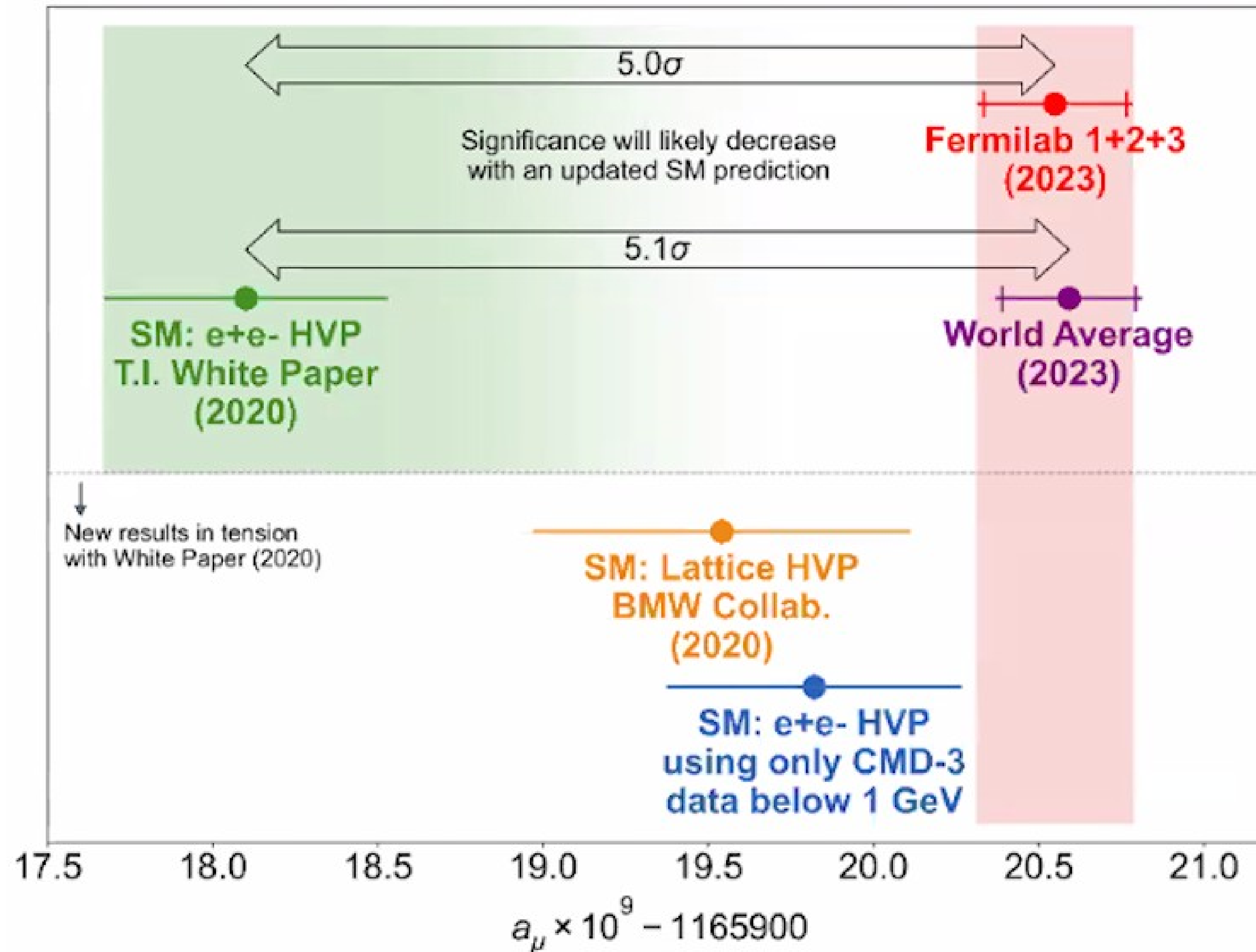

Disclaimer from A. Keshavarzi's Lattice 2023 talk:

- IMPORTANT: THIS PLOT IS VERY ROUGH!**
- TI White Paper result has been substituted by CMD-3 only for 0.33  $\rightarrow$  1.0 GeV.
  - The NLO HVP has not been updated.
  - It is purely for demonstration purposes  $\rightarrow$  should not be taken as final!

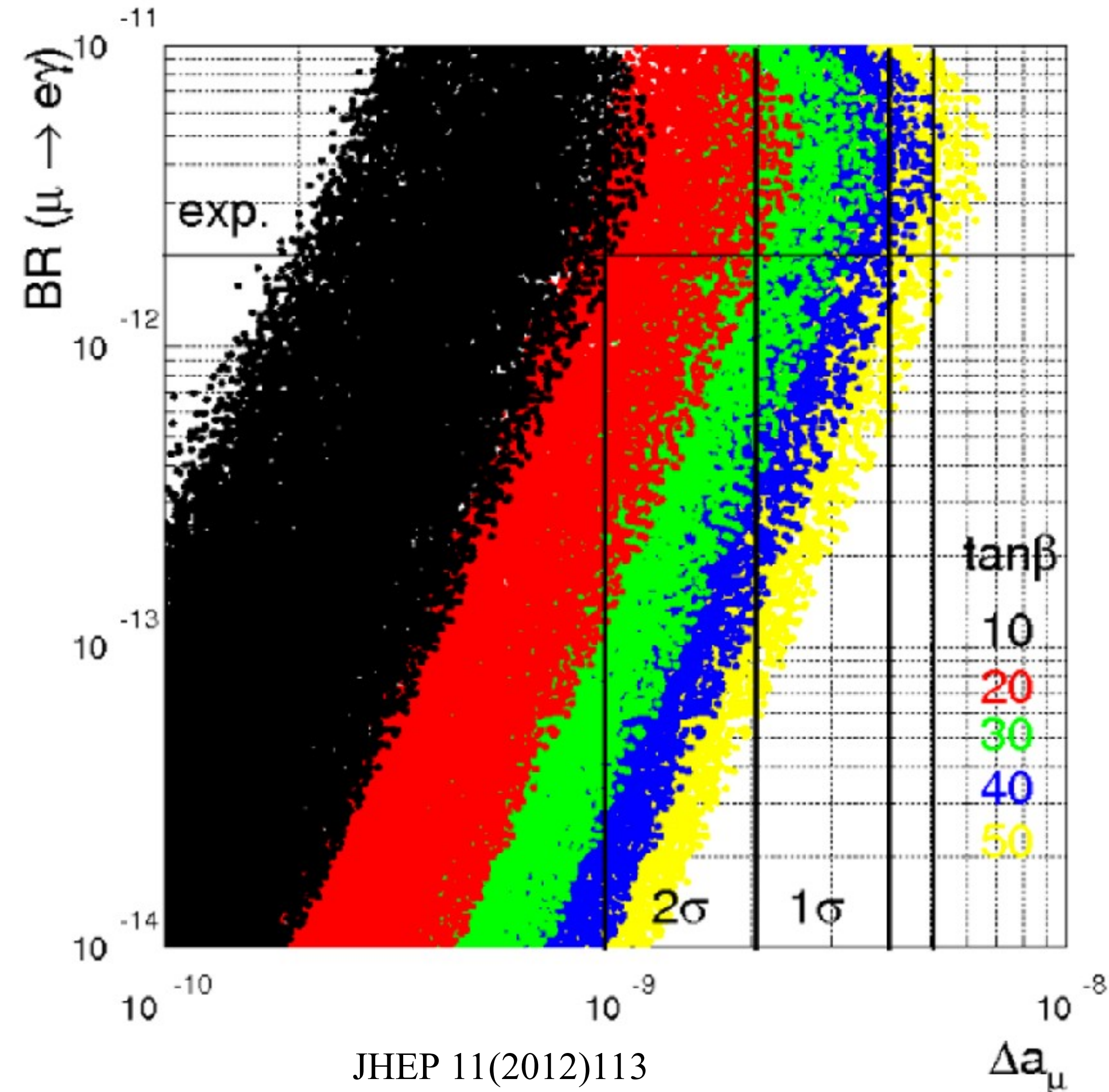

# After MEG II

- High Intensity Muon Beam project (HiMB) at PSI

- $10^{10} \mu^+/s$  (100× improvement)
- CDR by end of 2021
- Implementation during 2027/2028
- Science Case workshop 6-9 April 2021

- Future  $\mu \rightarrow e\gamma$  experiment for CLFV

- Goal:  $\text{Br}(\mu \rightarrow e\gamma) \sim 10^{-15}$
- Discover new physics and precision measurements
- Detector R&D to make maximum use of HiMB
- Resolution improvements
  - Calorimeter  $\rightarrow$  converter + pair spectrometer
- High rate tolerance
  - Drift chamber  $\rightarrow$  Silicon detector

- Possible to measure  $\mu \rightarrow eee$  at the same time

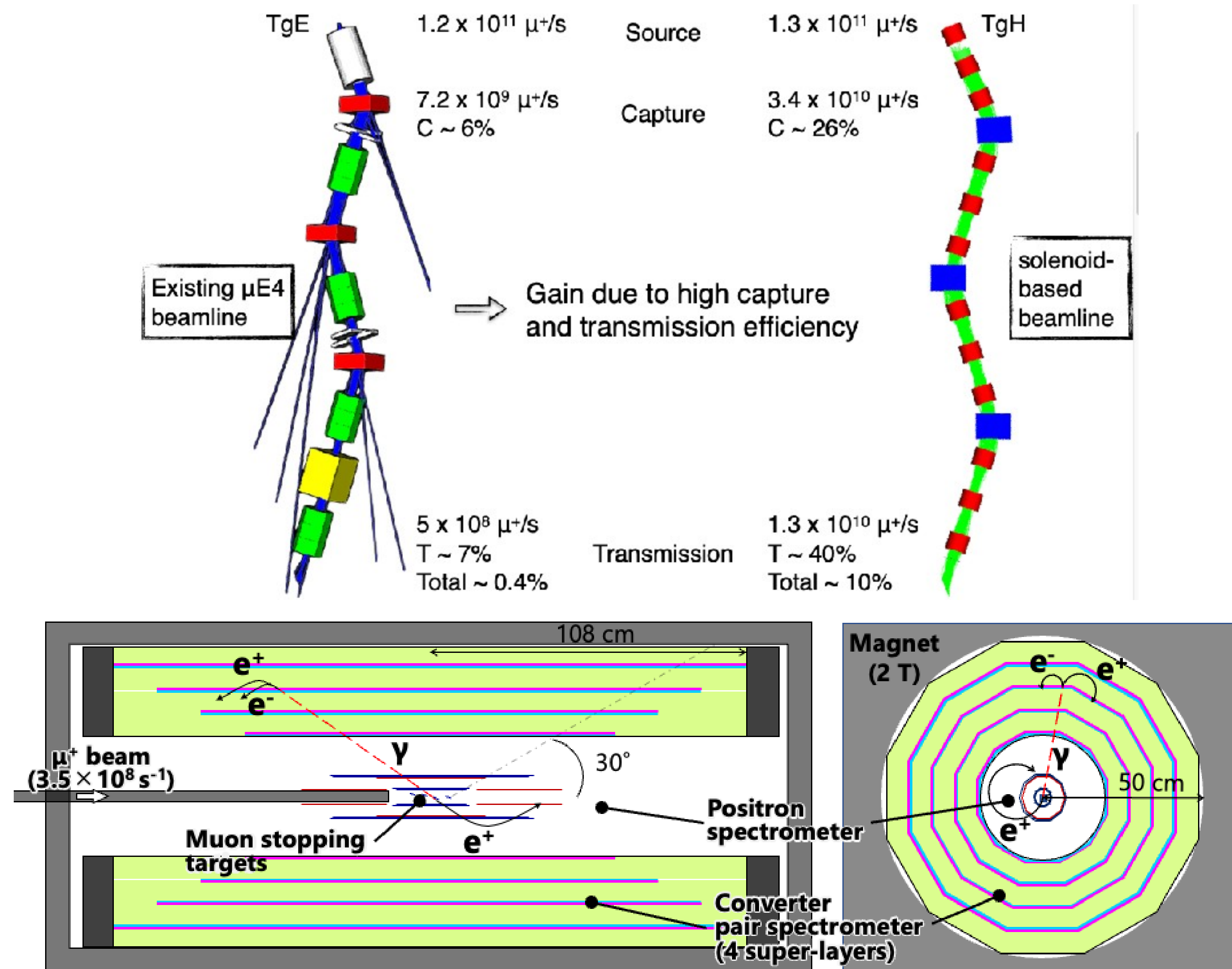

# Future $\mu \rightarrow e\gamma$

- Positron spectrometer
  - HV-MAPS + scintillator or mRPC
  - Resolutions
    - energy 0.3%(150keV) • time 30ps • angle 6mrad • detection efficiency 70%
- Gamma converter + pair spectrometer
  - Resolutions
    - energy 0.4% (200keV) • time 30ps • position 0.2mm • angle 50mrad • detection eff. 60%

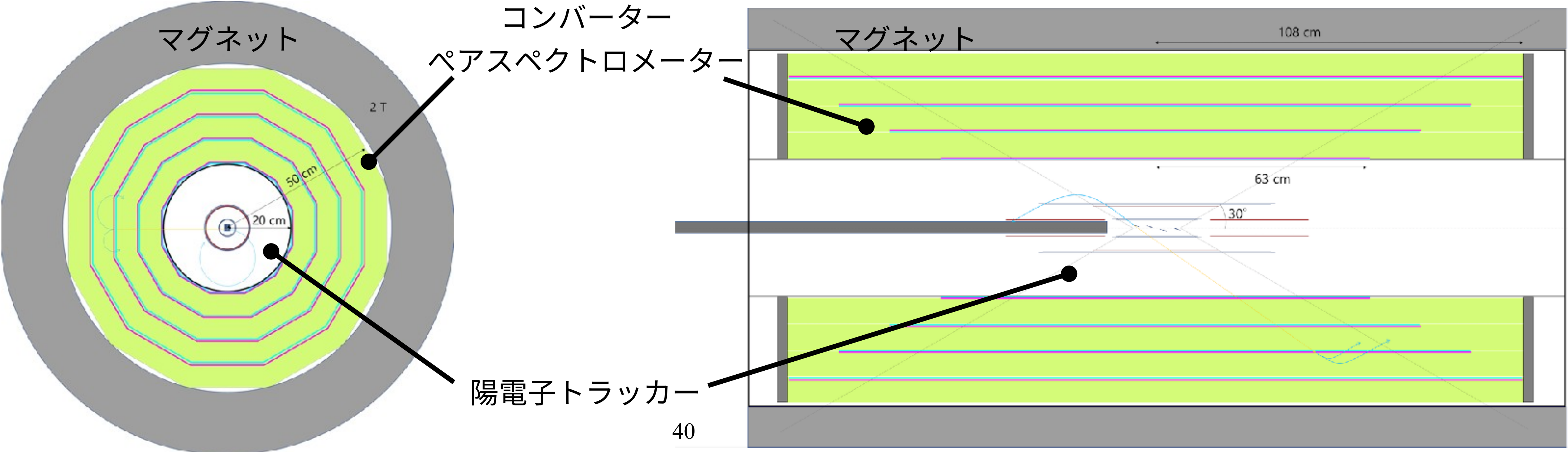
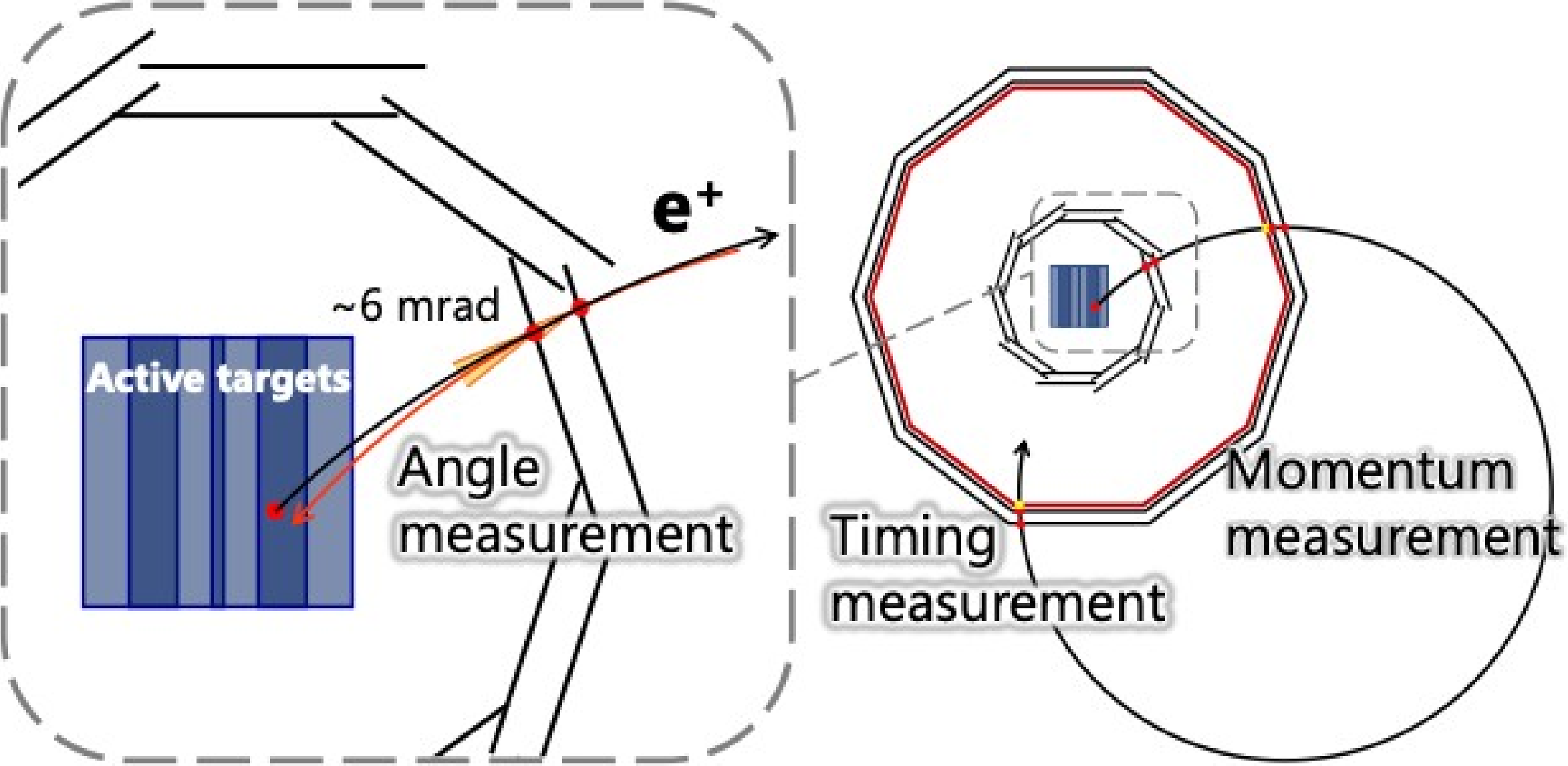

# Pattern of the relative predictions in several models

Model	$\mu \rightarrow eee$	$\mu N \rightarrow eN$	$\frac{\text{BR}(\mu \rightarrow eee)}{\text{BR}(\mu \rightarrow e\gamma)}$	$\frac{\text{CR}(\mu N \rightarrow eN)}{\text{BR}(\mu \rightarrow e\gamma)}$
MSSM	Loop	Loop	$\approx 6 \times 10^{-3}$	$10^{-3} - 10^{-2}$
Type-I seesaw	Loop*	Loop*	$3 \times 10^{-3} - 0.3$	0.1–10
Type-II seesaw	Tree	Loop	$(0.1 - 3) \times 10^3$	$\mathcal{O}(10^{-2})$
Type-III seesaw	Tree	Tree	$\approx 10^3$	$\mathcal{O}(10^3)$
LFV Higgs	Loop <sup>†</sup>	Loop* <sup>†</sup>	$\approx 10^{-2}$	$\mathcal{O}(0.1)$
Composite Higgs	Loop*	Loop*	0.05 – 0.5	2 – 20

ArXiv: 1709.00294

# Examples of new physics

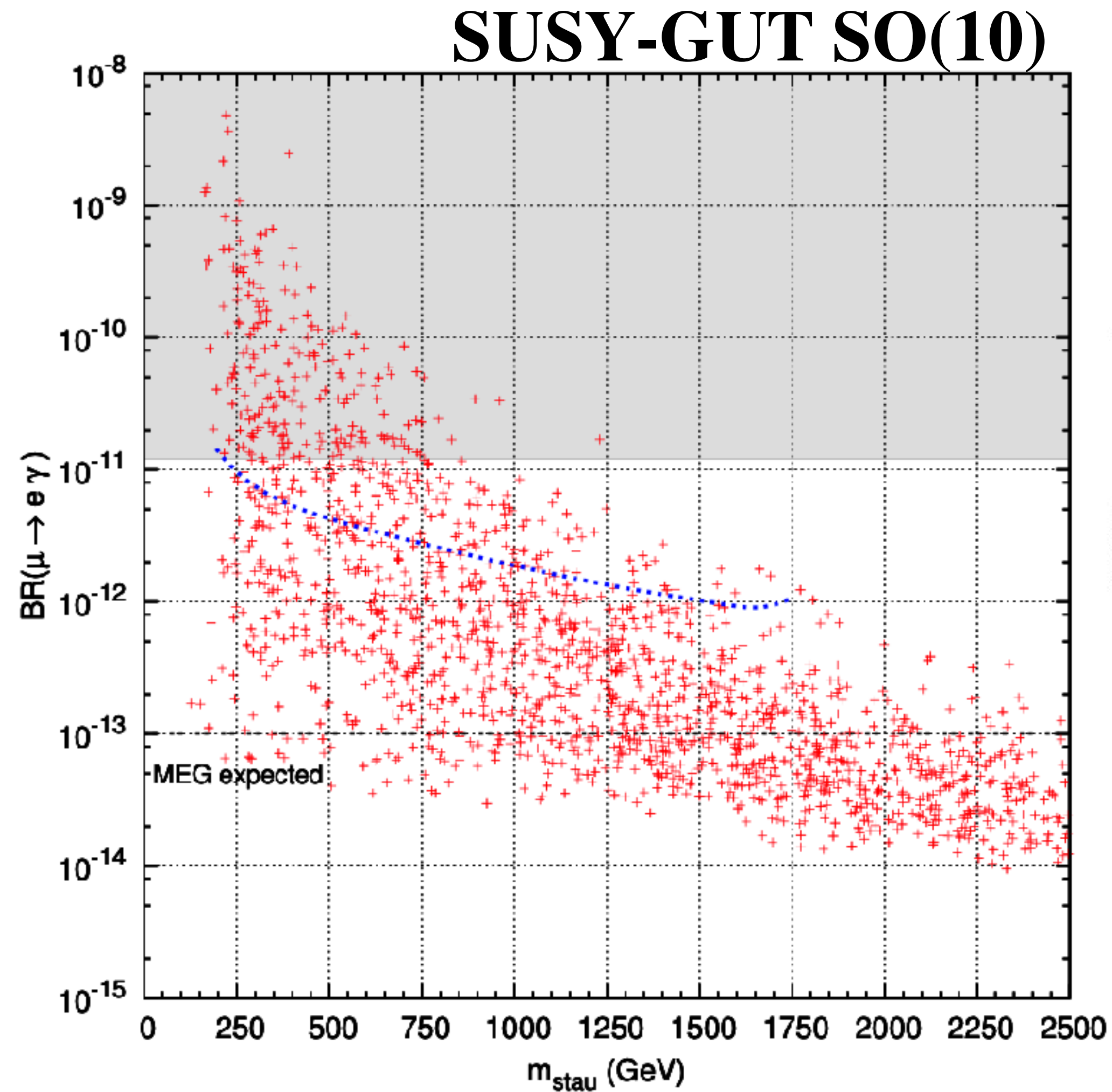

JHEP 0912(2009)057

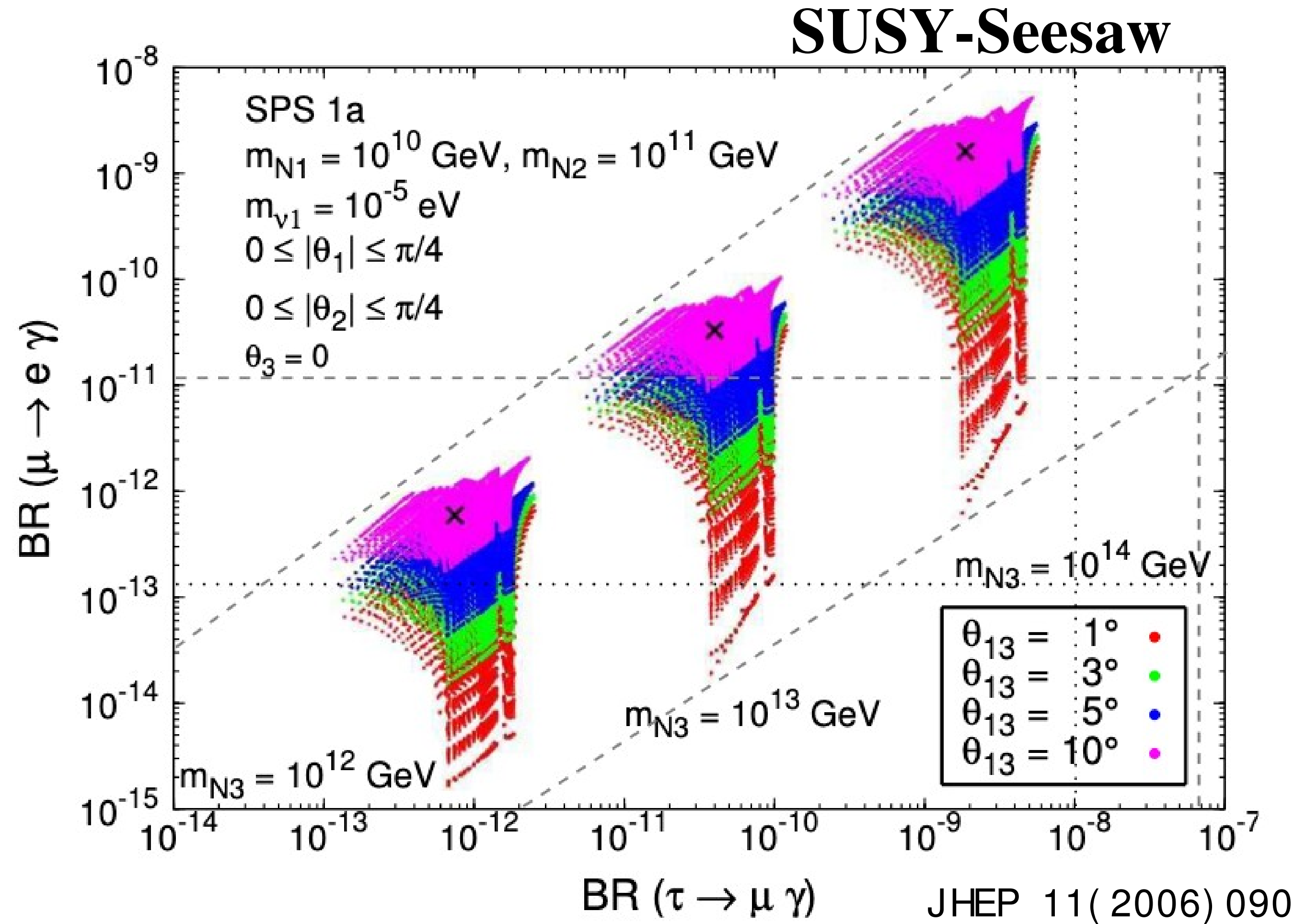

Real chance for discovery

Already some regions from theoretical expectation excluded

# New physics models

Dipole

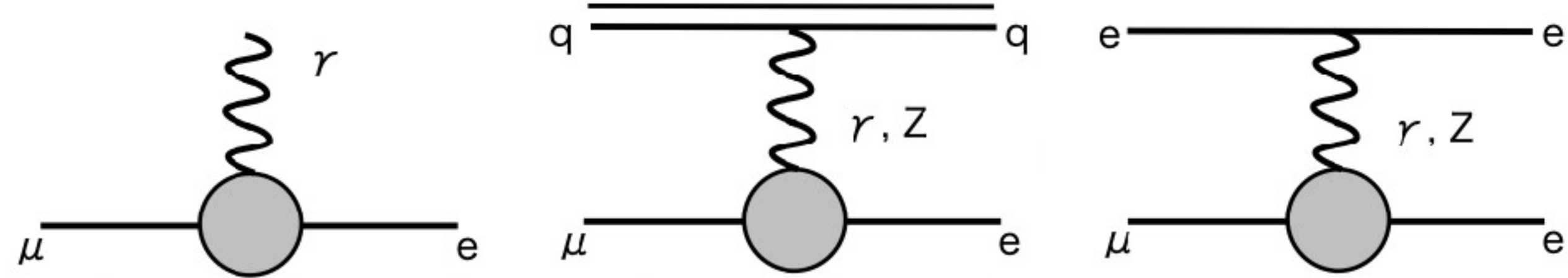
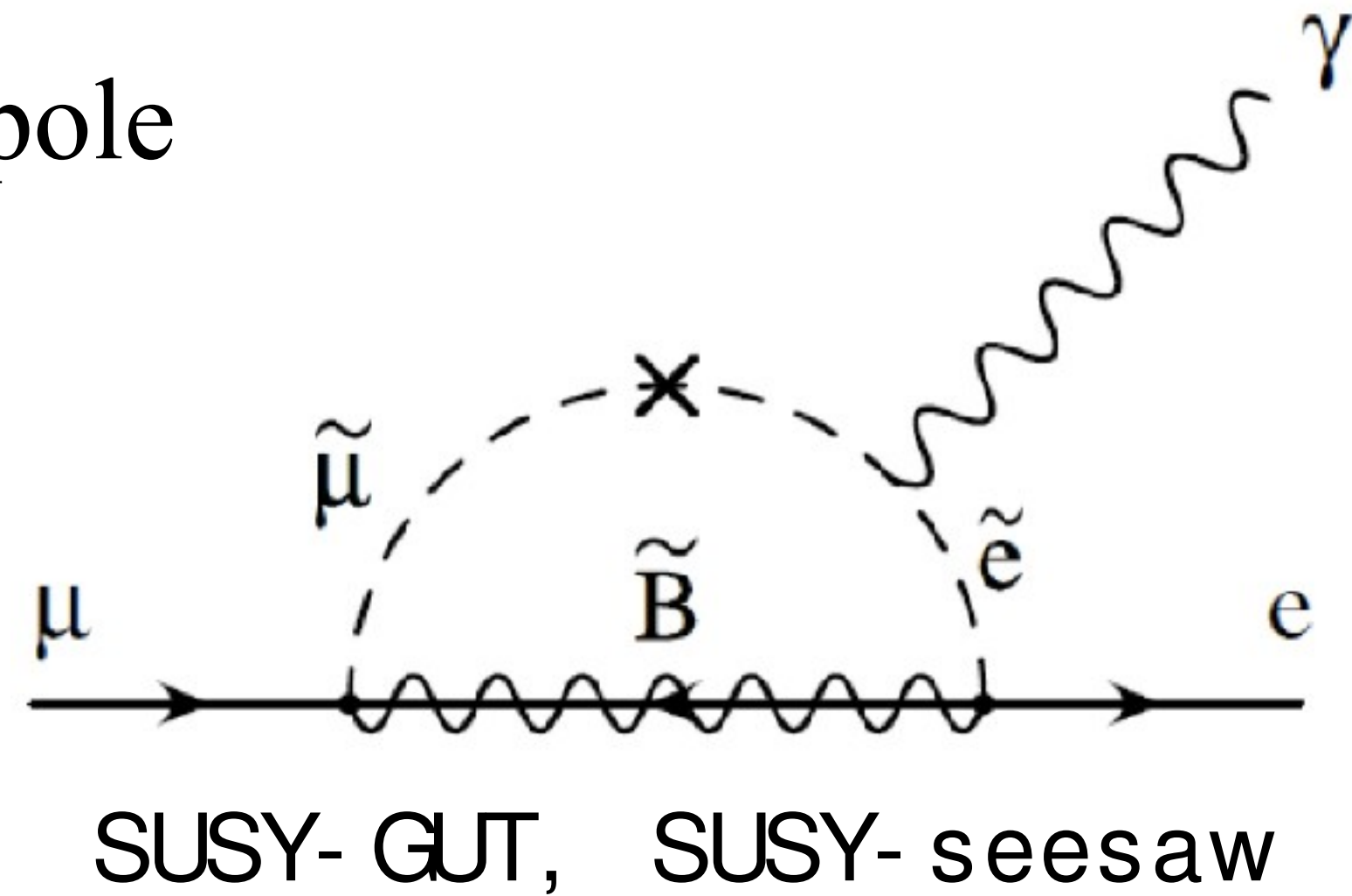

$$\text{Br}(\mu \rightarrow e \gamma) : \text{R}(\mu\text{-Al} \rightarrow e\text{-Al}) : \text{Br}(\mu \rightarrow 3e)$$

$$= 1 : 1/170 : 1/390$$

Tree

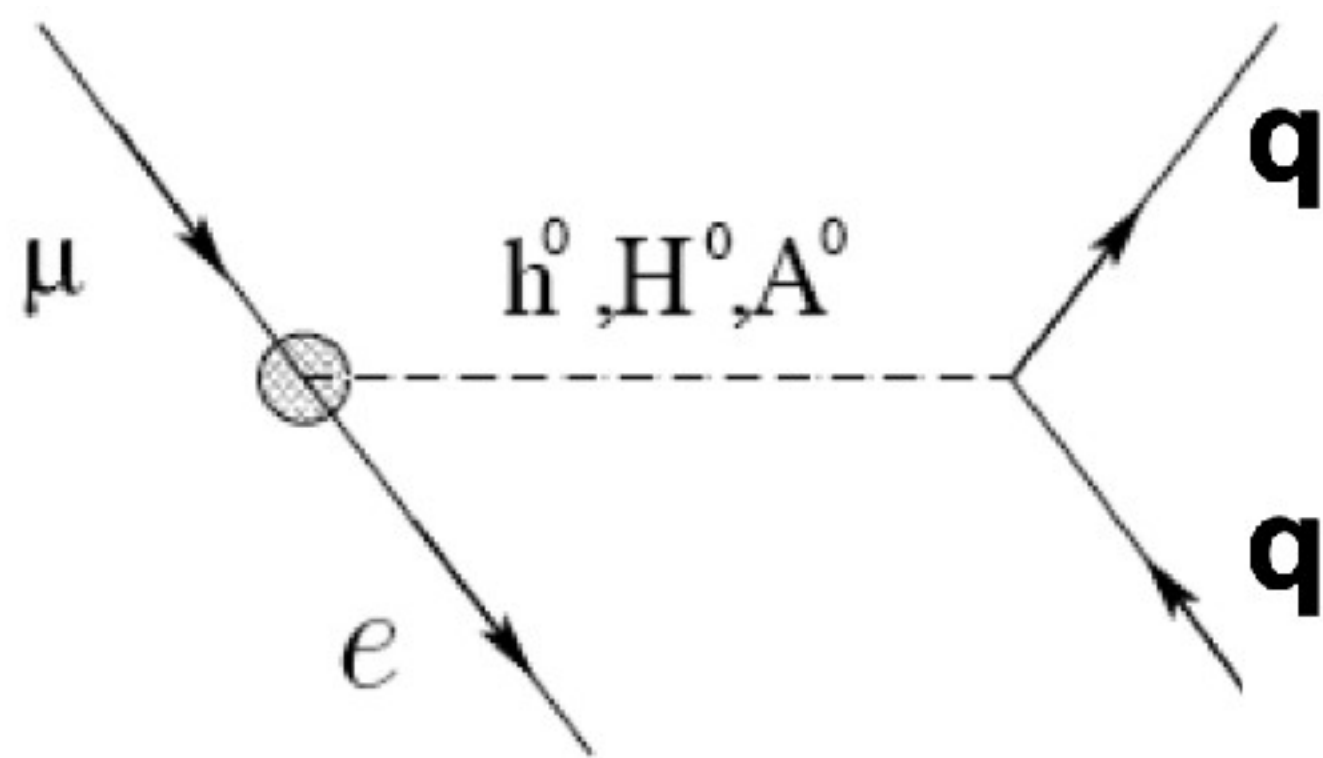

Scalar: RPV SUSY

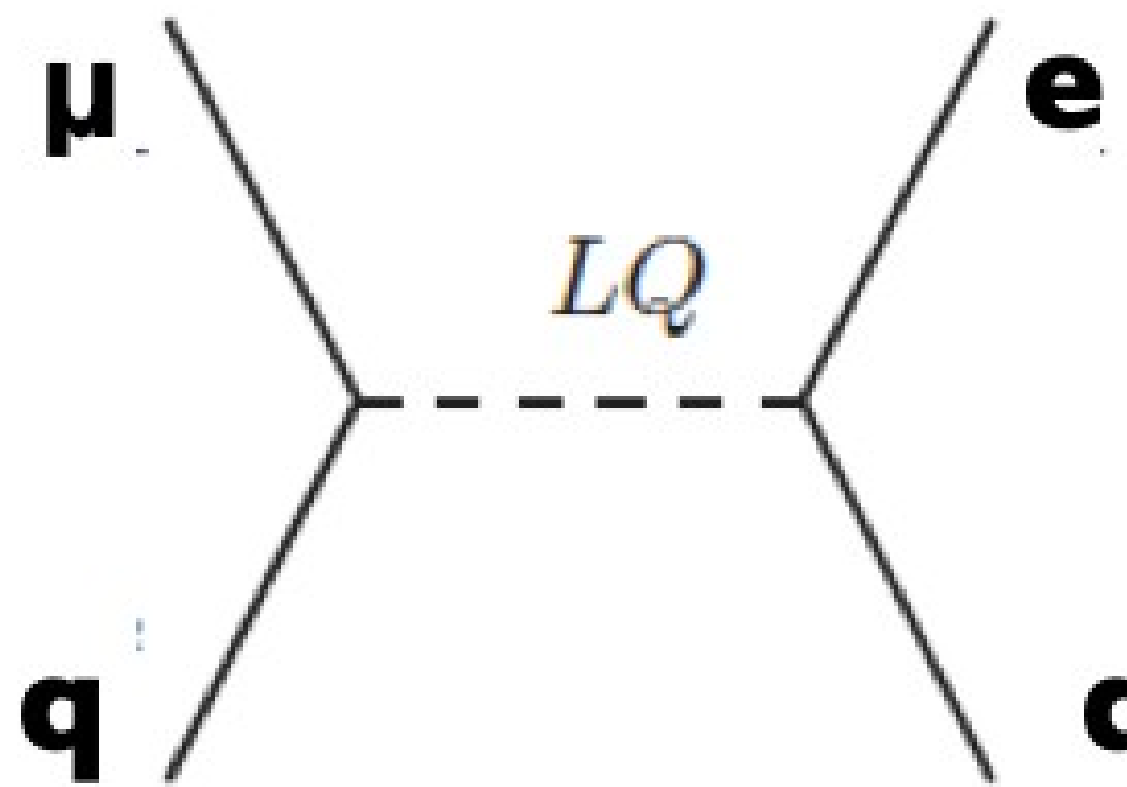

Vector: Leptoquarks, ...

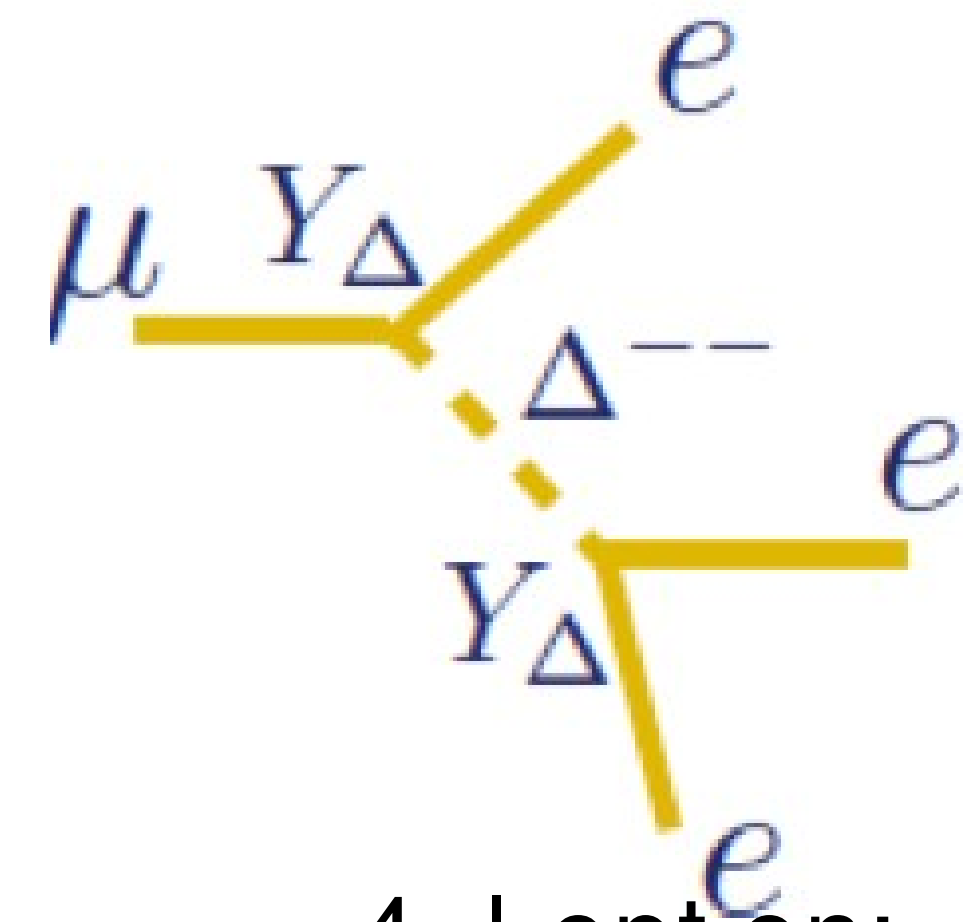

4- l ept on:

Type II seesaw, RPV SUSY,  
LRSM, ...

# Future $\mu \rightarrow e\gamma + \text{Mu}3e$ ?

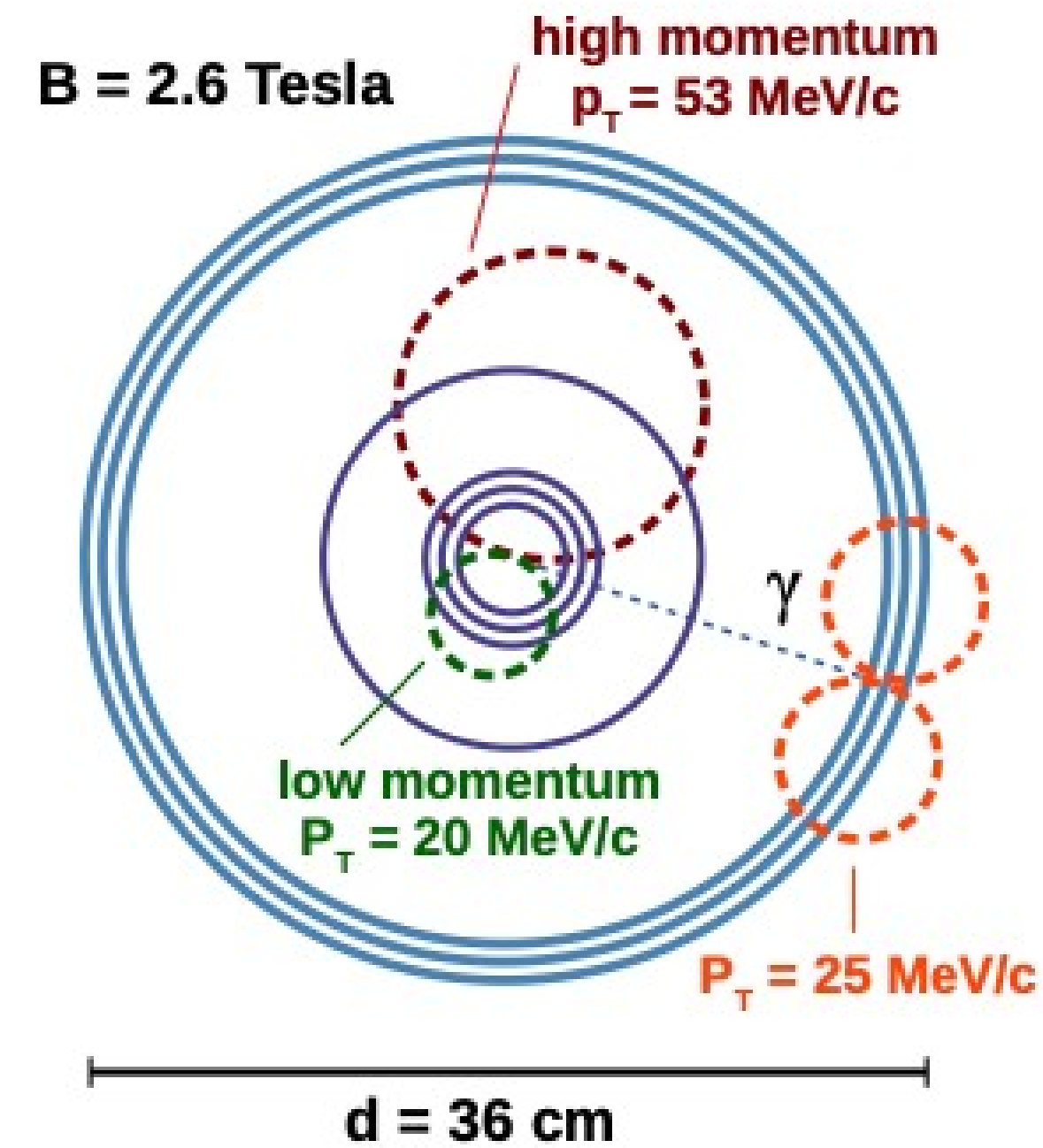
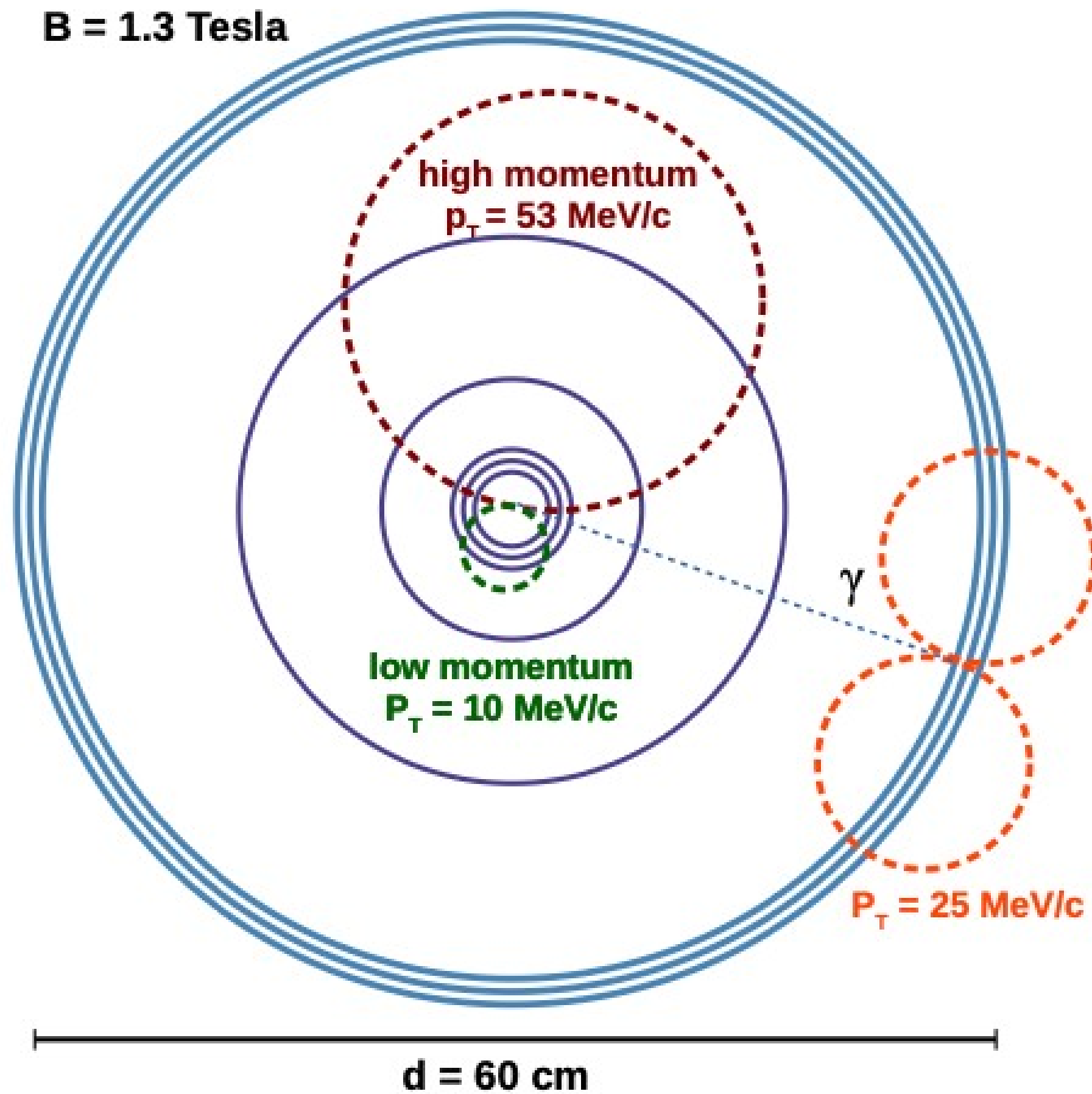

Open discussions on designs and technologies for future experiments. Currently the study group are mostly from MEG II and Mu3e, but always welcoming new participants