

# Trigger electronics of the Fast Forward Detector for MPD experiment

Victor Rogov, Sergey Sergeev, Vladimir Yurevich, Sergey Sedykh, Pavel Grigoriev, Nikita Lashmanov

*Joint Institute for Nuclear Research, Dubna, Russia*

*TIPP 2026*

# Fast Forward Detector in MPD Experiment

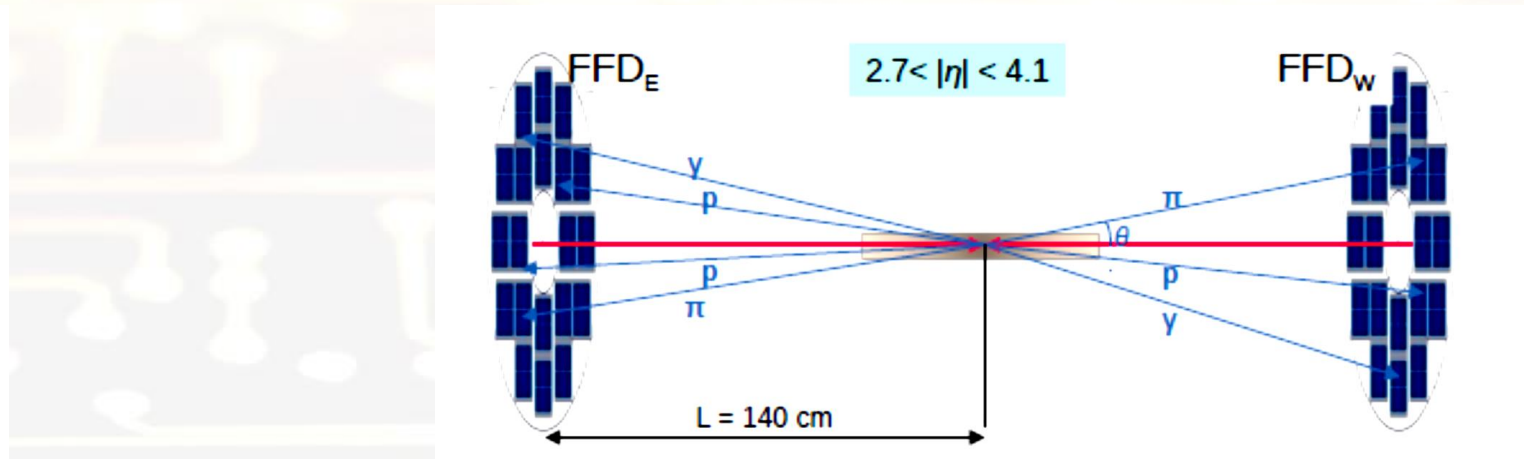
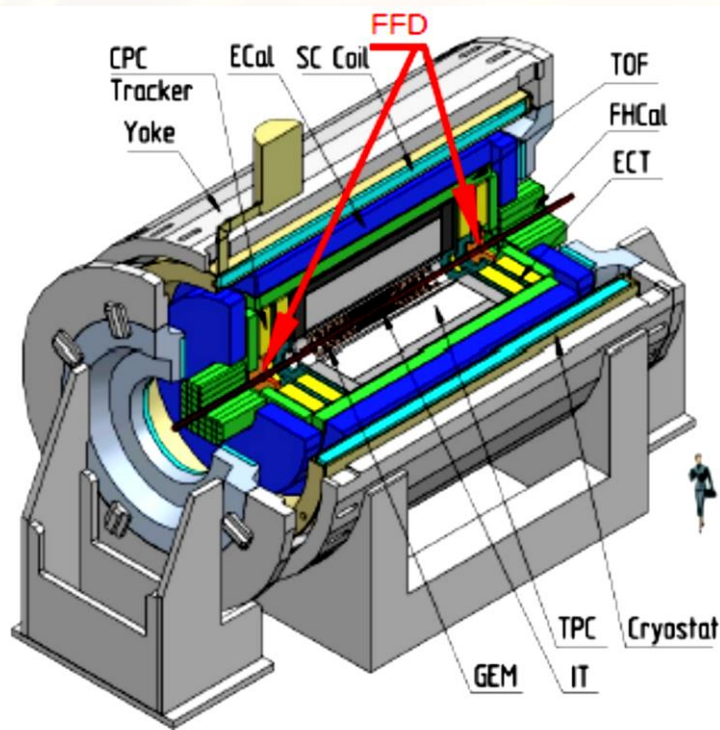

## Aims of the FFD in MPD experiment

- Provide fast interaction trigger and determination of interaction point with resolution  $\sigma_z < 3$  cm
- Generate t0- pulse for TOF detector with time resolution  $\sigma_t < 50$  ps

## FFD concept

Each subdetector has modular structure with 20 Cherenkov modules and 80 independent channels of registration of relativistic charged particles and high-energy photons by conversion to electrons in Pb plate (converter).

**Multi-Purpose Detector experiment** at NICA heavy ion collider is created for study properties of hot and dense nuclear matter produced in nucleus – nucleus collisions in center of the setup.

**Fast Forward Detector (FFD)** is a part of MPD facility and it consists of two Cherenkov subdetectors  $FFD_E$  and  $FFD_W$  located around beam pipe at a distance of 140 cm from MPD center.

# FFD Modules and Front-End Electronics

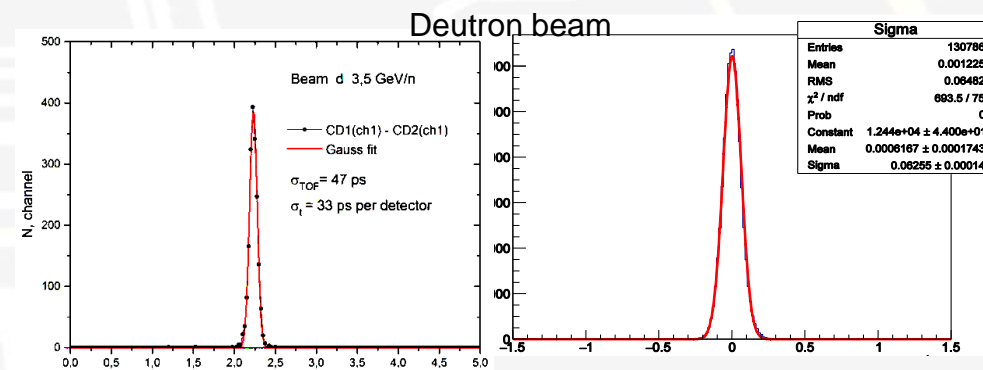
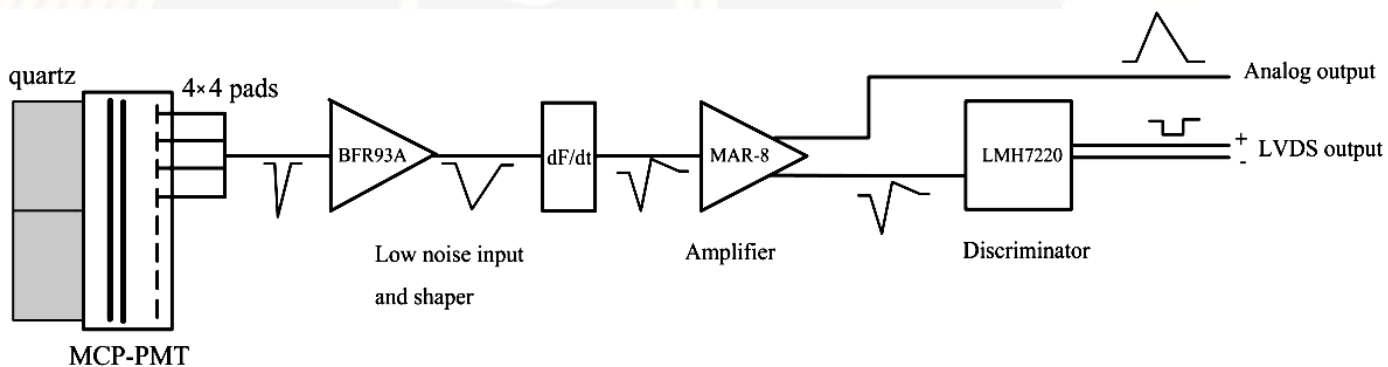
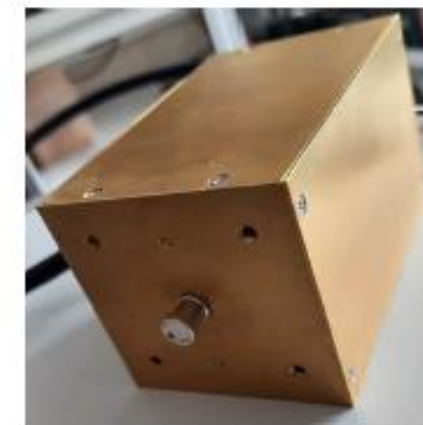
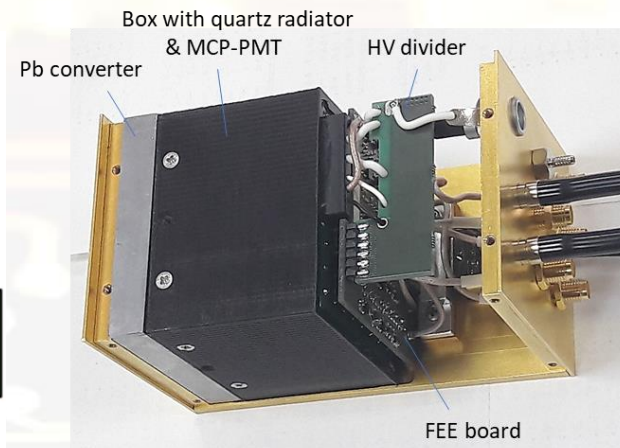
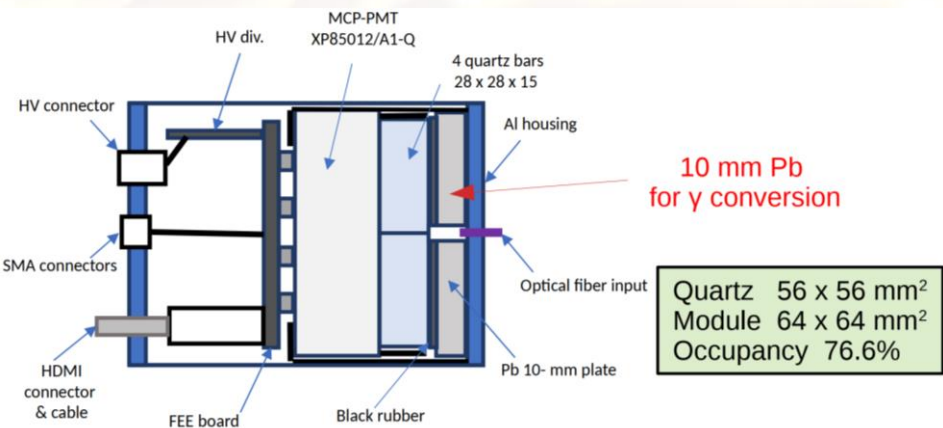

Digitizer CAEN mod.N6742

$\sigma_{TOF} = 47$  ps  
 $\sigma_t = 34$  ps

TDC72VHL  
Realistic chain of cables and electronics  
 $\sigma_{TOF} = 62$  ps  
 $\sigma_t = 44$  ps

## FEE scheme of a single FFD channel

# FFD Sub-Detectors

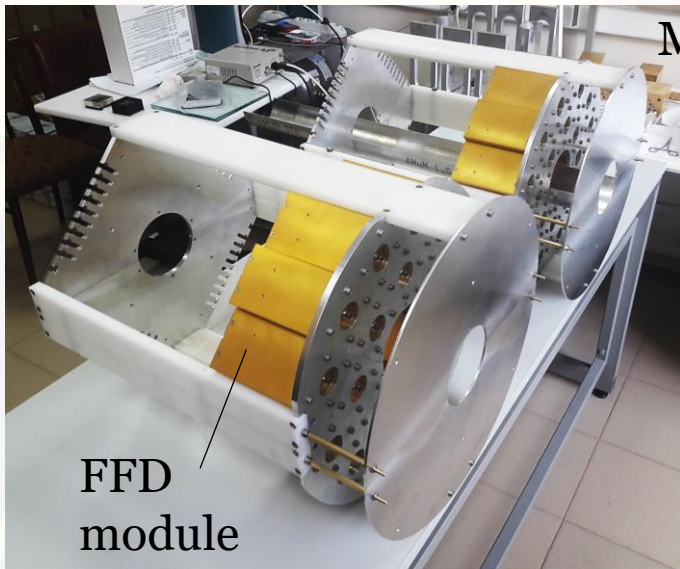

Mechanical construction of FFD sub-detectors

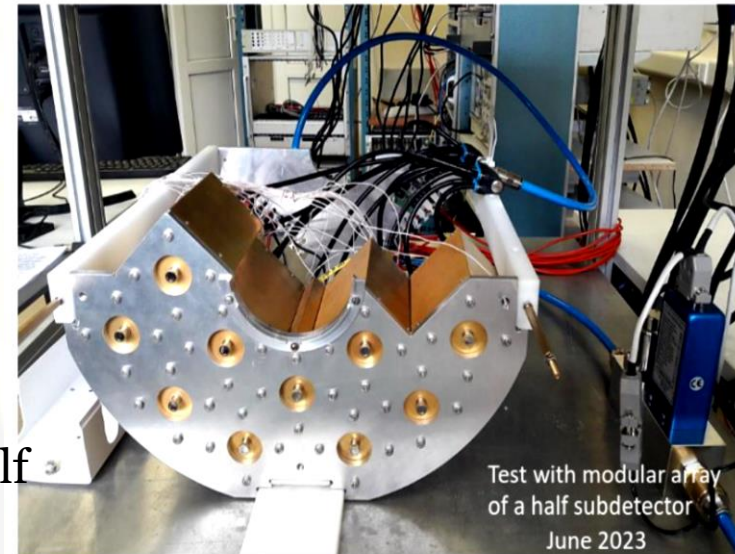

Test measurements with a half sub-detector

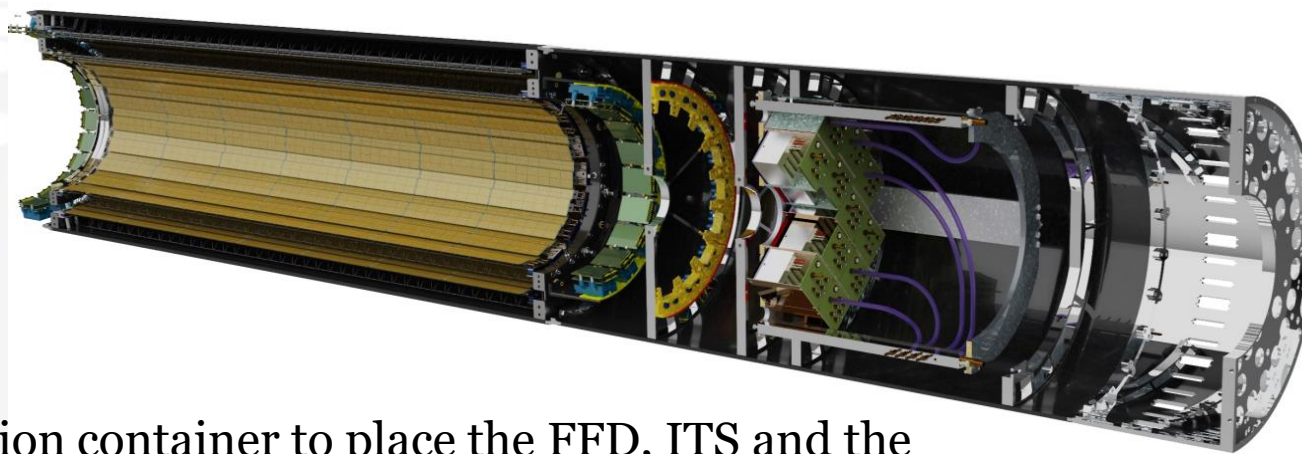

The installation container to place the FFD, ITS and the beam pipe

# FFD Sub-Systems

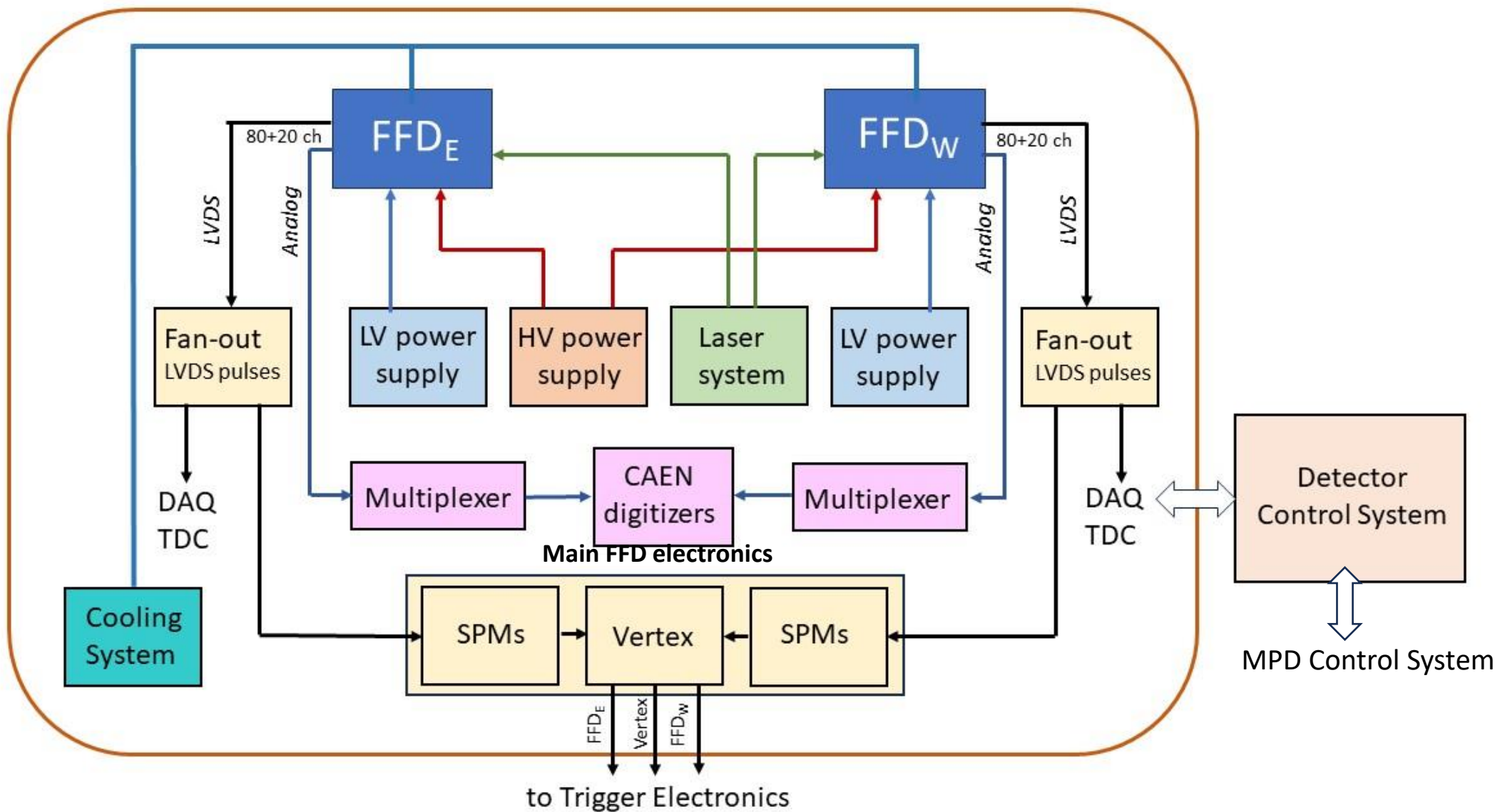

# Laser System for Calibration and Monitoring

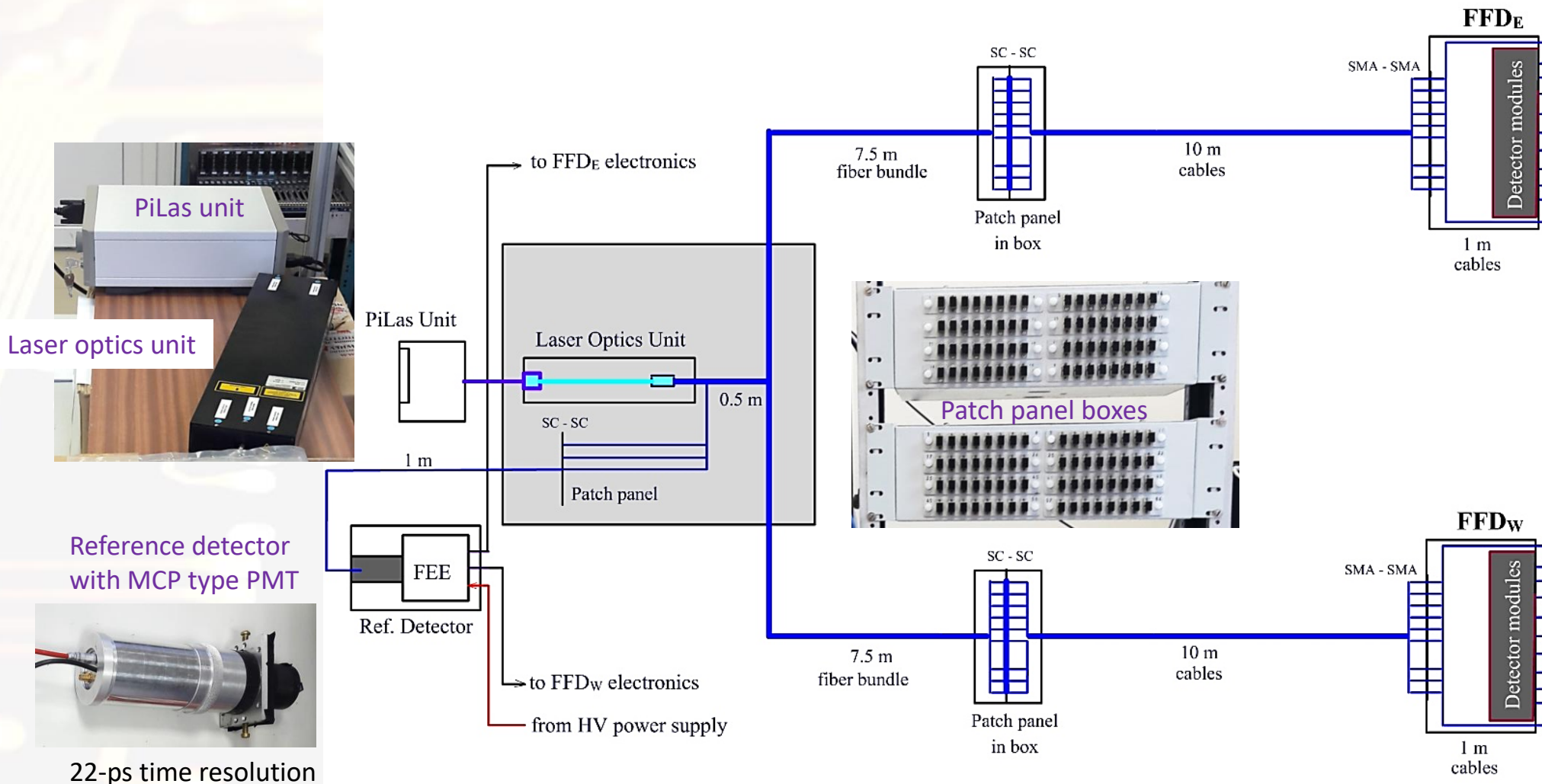

Laser optics unit

Reference detector with MCP type PMT

22-ps time resolution

# Test with the Laser System

PiLas laser with 30-ps pulse width and 405-nm wavelength

1. PiLas control unit
2. box with laser head and optical system
3. quartz fiber bundles 7.5 m

The 20 fibers with similar pulse heights are selected for each FFD sub-detector (FFD<sub>W</sub> and FFD<sub>E</sub>)

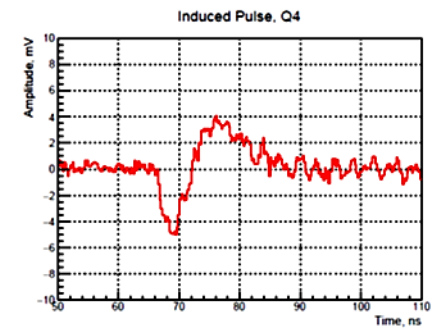
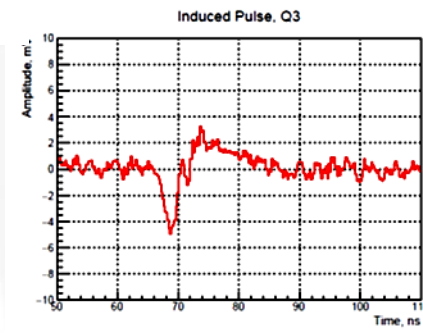
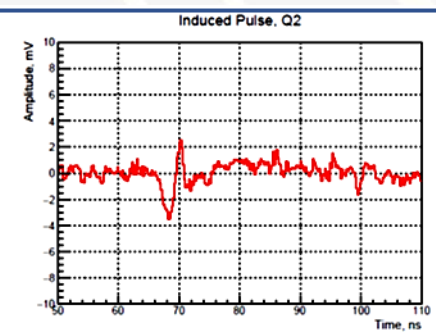
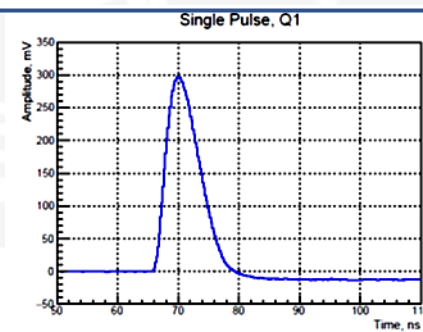
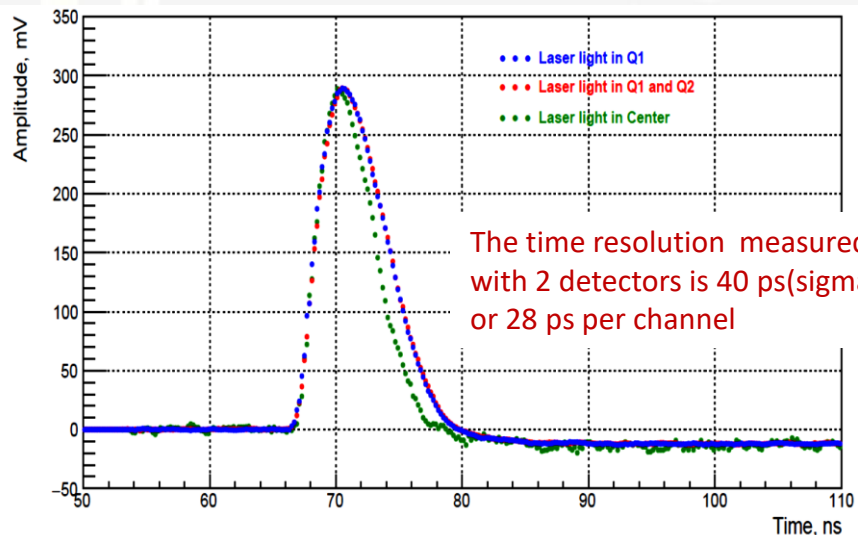
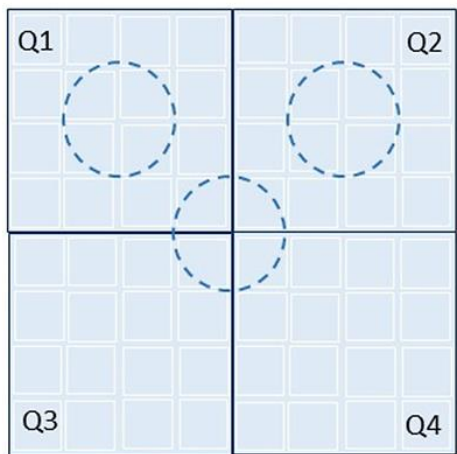
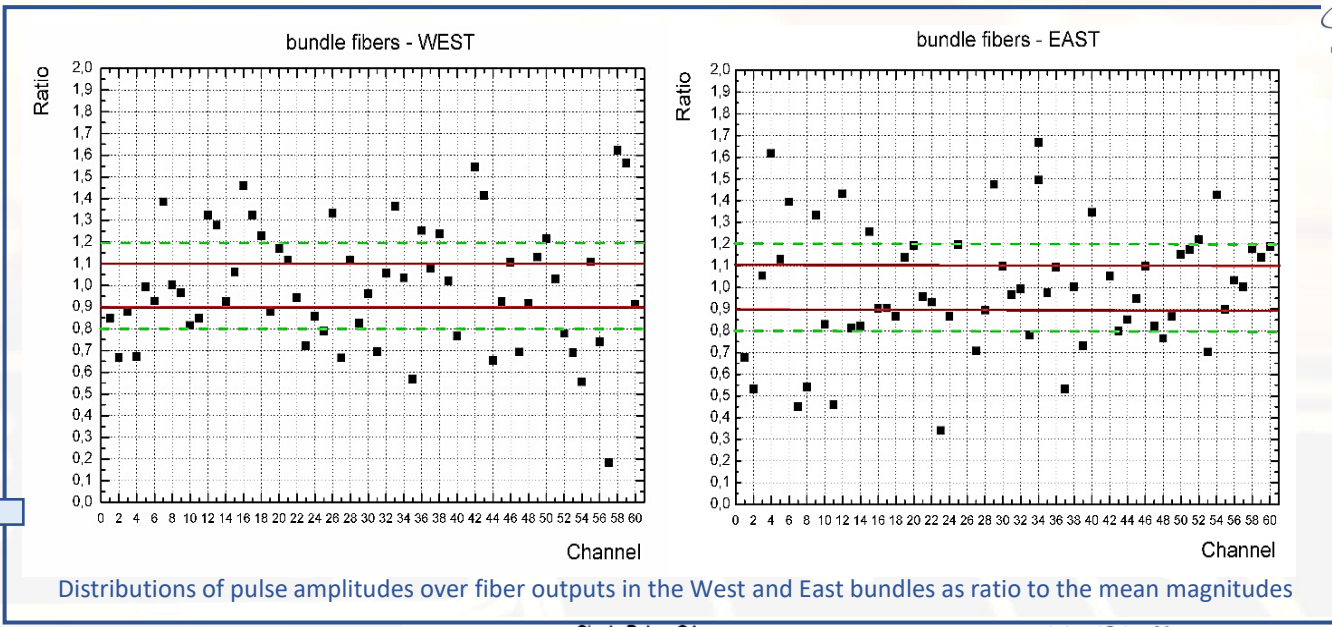

A scheme of laser spots on XP85012 photocathode (blue circles) for three cases of optical fiber inputs

The pulse shapes measured with laser for three cases of optical fiber inputs

The cross-talk responses in Q2 – Q4 channels, laser pulse in center of the quartz bar Q1

# Cable testing

## HDMI cables (ps.- timing)

Time resolution as a function of cable length

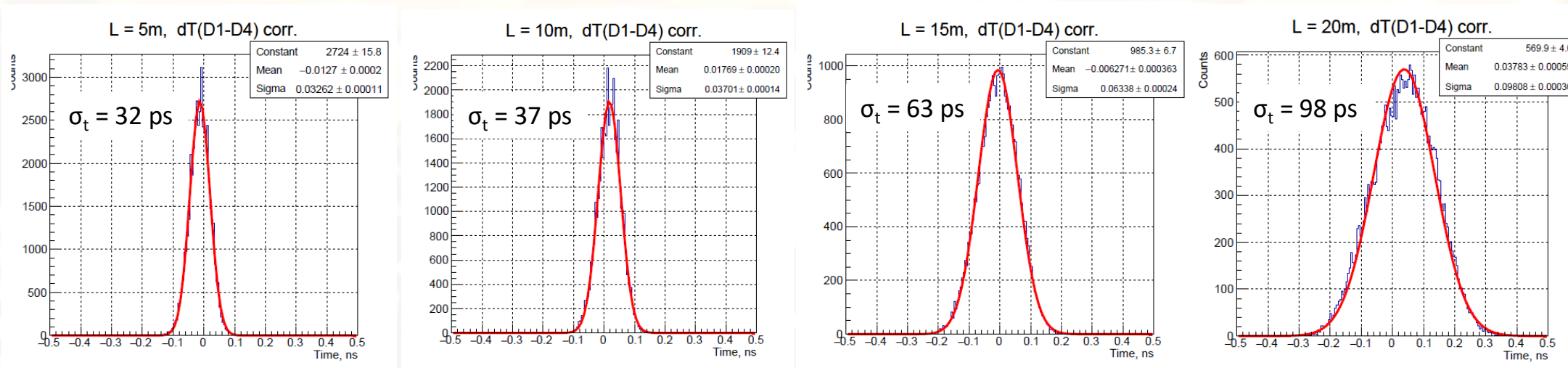

Time delay difference of the produced 10-m cables

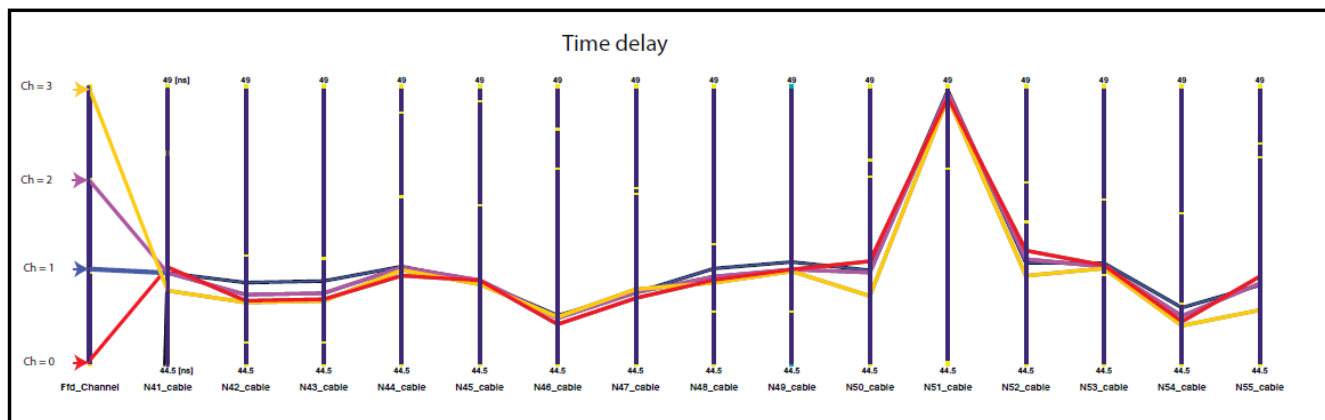

The special 10-m HDMI cables were produced according our requirements in St. Petersburg

# Fan-out & LV and Multiplexer of Analog Pulses



View of LVM and crate

Fan-out & LV module provides:

- Power supply for 5 FFD modules (Power supply for 5 FFD modules which use three independent voltages for detector FEE. The supplies are monitored and controlled with high precision)

- Signal splitting

The LVDS signals coming from the detector modules of each arm are split into 2 branches. One branch goes to the TDC modules and the second one goes to the FFD signal processor modules. These modules generate FFD trigger used by the MPD trigger processor



FFD intermediate crate (2pc)

- 4 LVM modules
- PWR and RS 485 distribution board

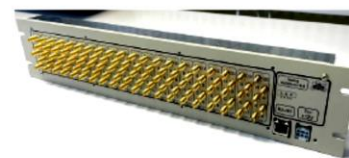
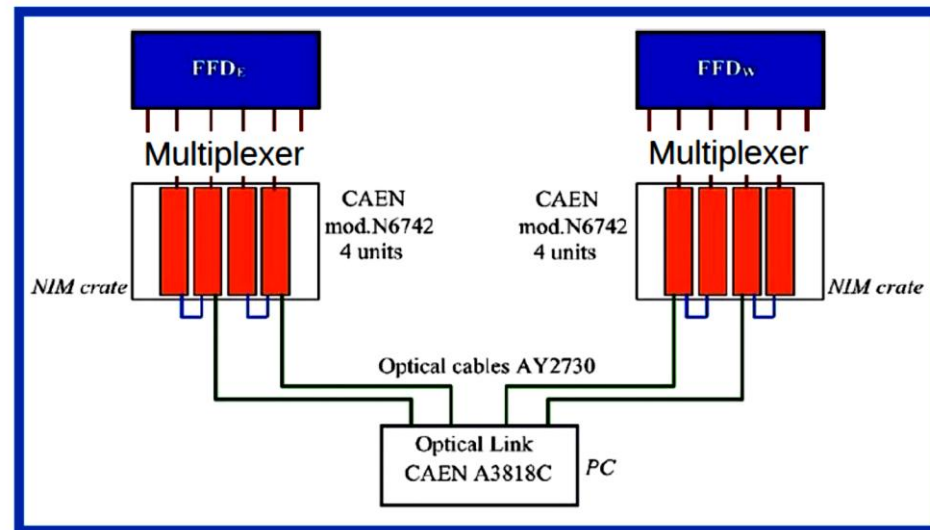

Analog 4 to 1 multiplexers

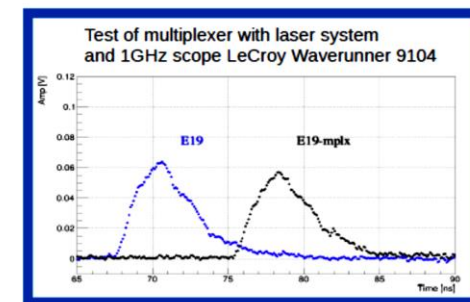

20 ch. analog multiplexor 4 to 1

# FFD in the MPD Trigger

The aim of main FFD electronics is processing of pulses from 80 + 80 channels of FFD sub-detectors for generation of special signals for trigger electronics:  $FFD_E$ ,  $FFD_W$  and Vertex

The Vertex signal confirms that the measured time gap between FFDE and FFDW signals is in the selected interval along the beam axis around center of the MPD detector

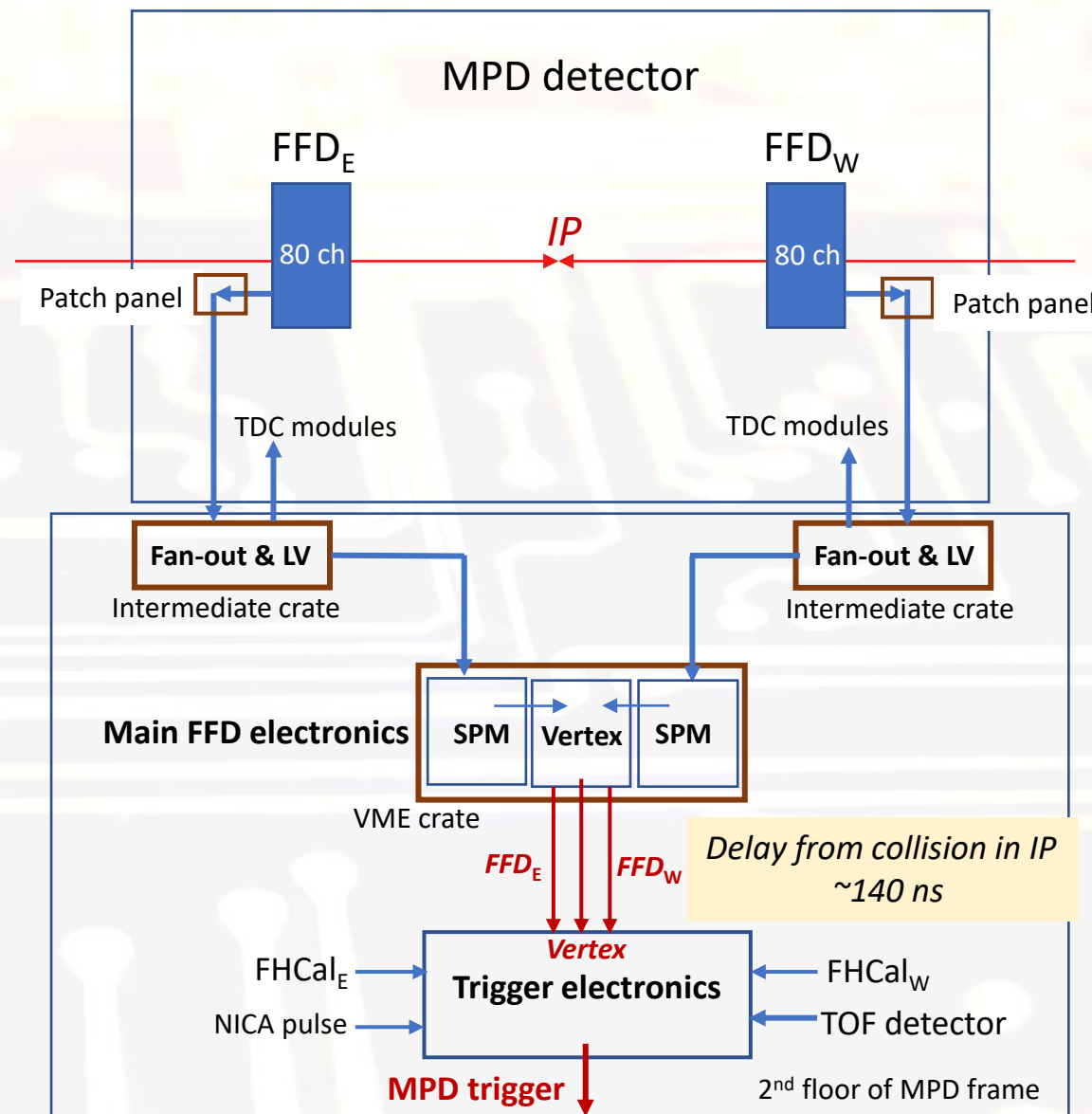

# Main FFD Electronics

Functional scheme of SPM and Vertex modules based on FPGA with backplane communication

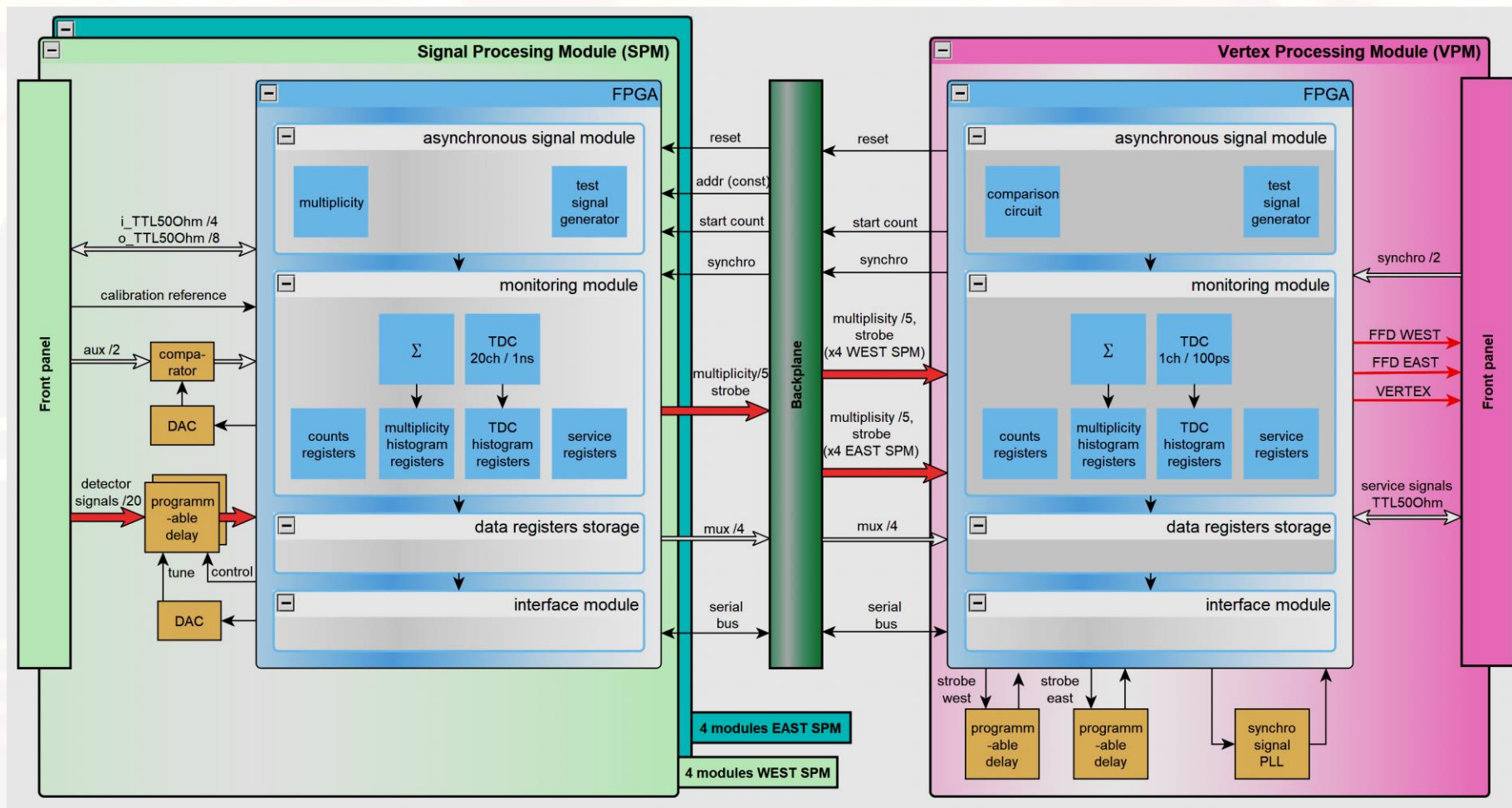

All modules are placed in a single VME crate with custom backplane

# Signal Processing Modules (SPM)

- In the central FFD crate the FFD pulses are processed in 8 signal processing modules (SPMs), 4 modules per arm
- The SPM provides following jobs:
  - Tuning delays for each FFD ch.(SPM has 20ch.)
  - Fast «OR» and multiplicity signal generation
  - Counting hits in FFD channels
  - Signal multiplicity histogram building
  - Channel signal width distribution histogram building (20 histograms per SPM)
  - Generating up to 8 AUX TTL 500ohm signals
  - Receiving up to 4 AUX TTL 500ohm signals and 2 analog signals with discriminators
  - Data transfer via the crate backplane or an individual optical link
  - Remote FPGA programming

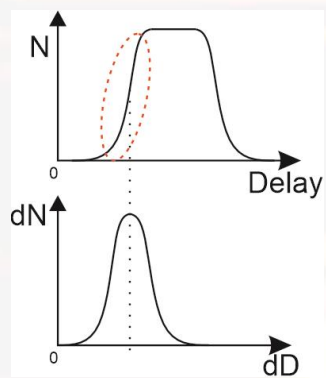

**Delayed coincidence method**

Delay tuning process

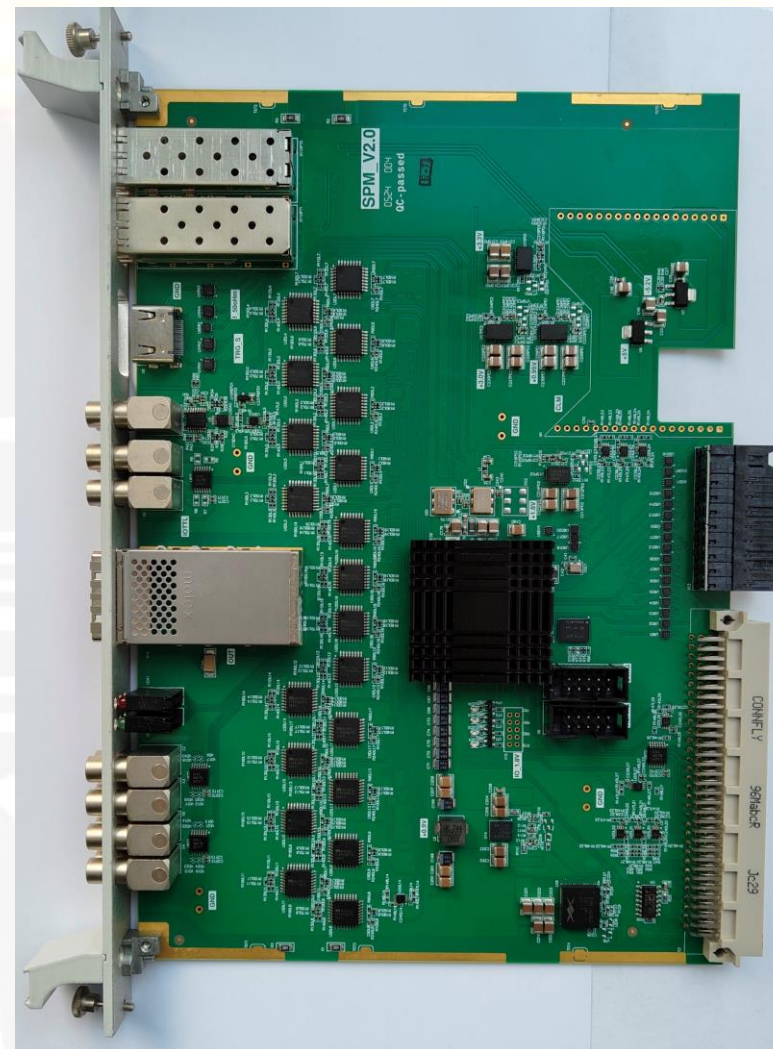

**View of SPM**

# Vertex Processing Module (VPM)

- The VPM provides following jobs:
  - Collecting of all signals from SPM's
  - Splitting and SPM's signals for east and west and generating «OR» for SPM's signals
  - Tuning the delay for fast OR signal
  - Generating Vertex signal and trigger signal for each side
  - Generating up to 12 AUX output TTL 50ohm signals
  - Receive up to 8 AUX TTL 50ohm signals and 2 analog signals with discriminators
  - Data transfer via RS-485 or optical link

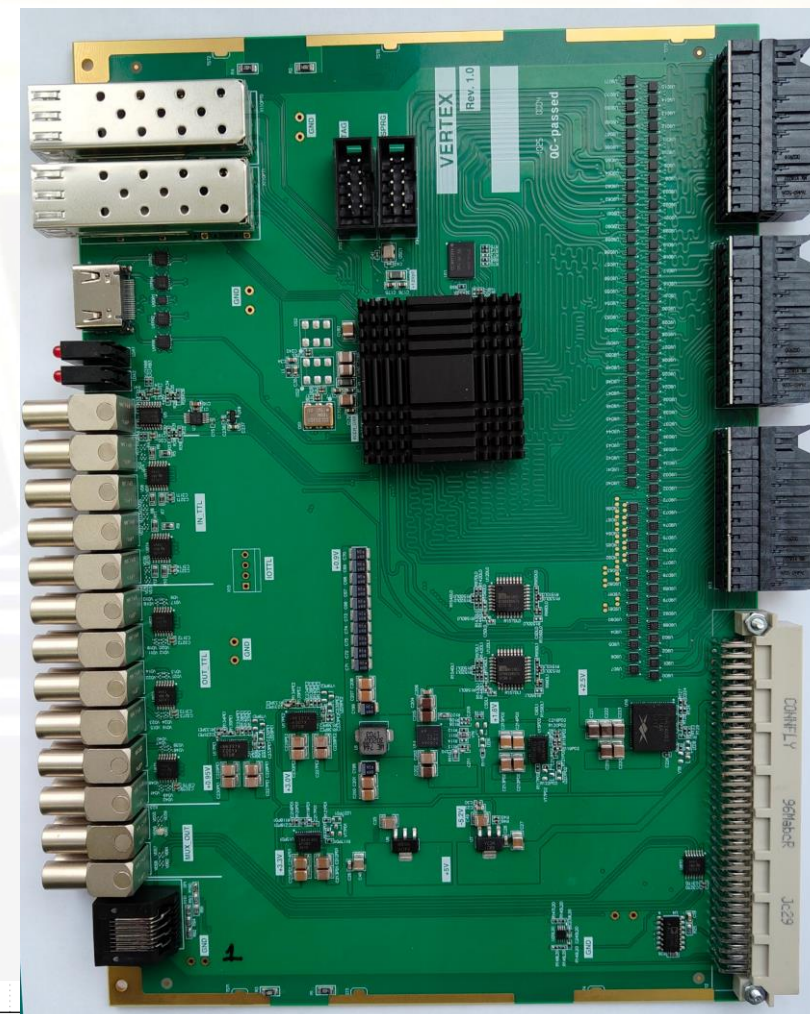

View of VPM

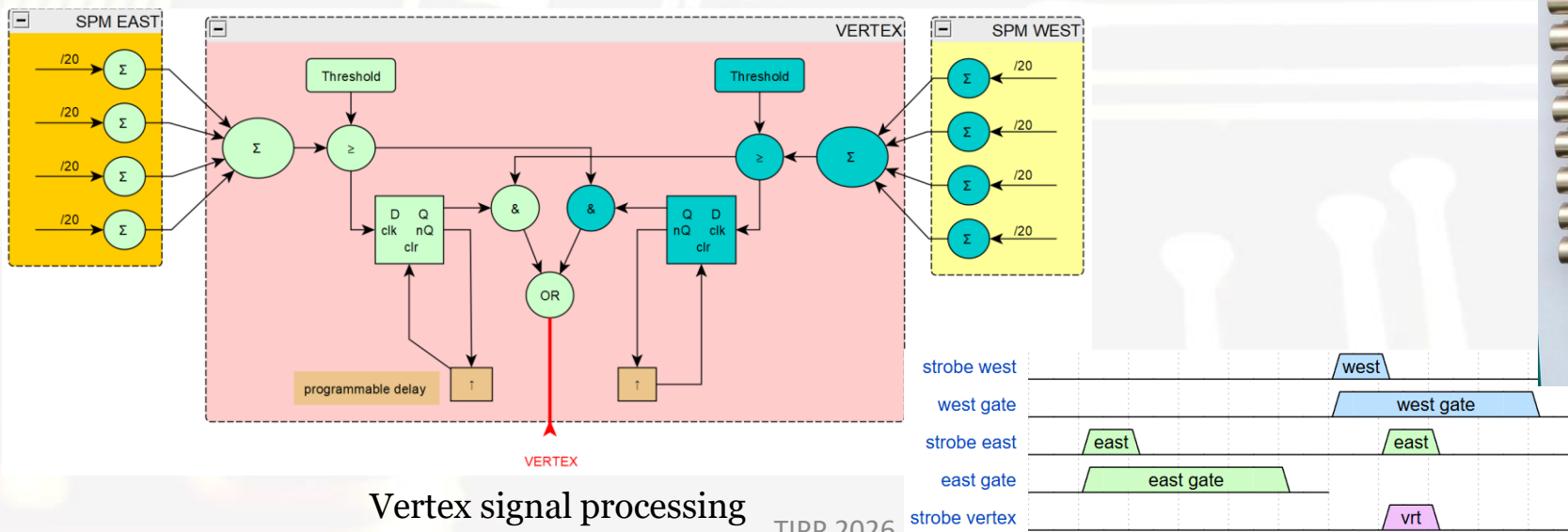

# Scheme of the Stand for Test Measurements in the Lab

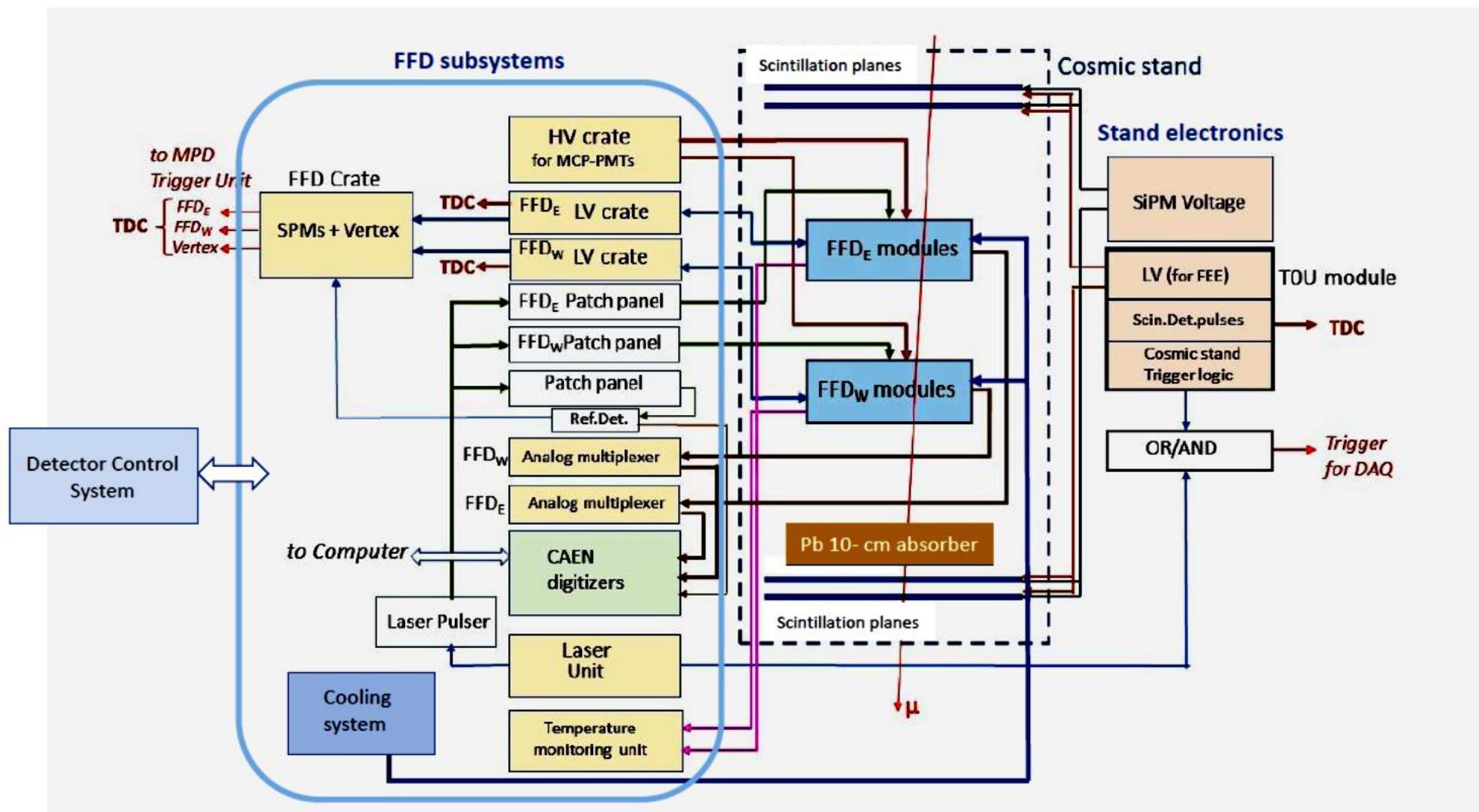

# Tests with Cosmic Stand and Laser System in the Lab

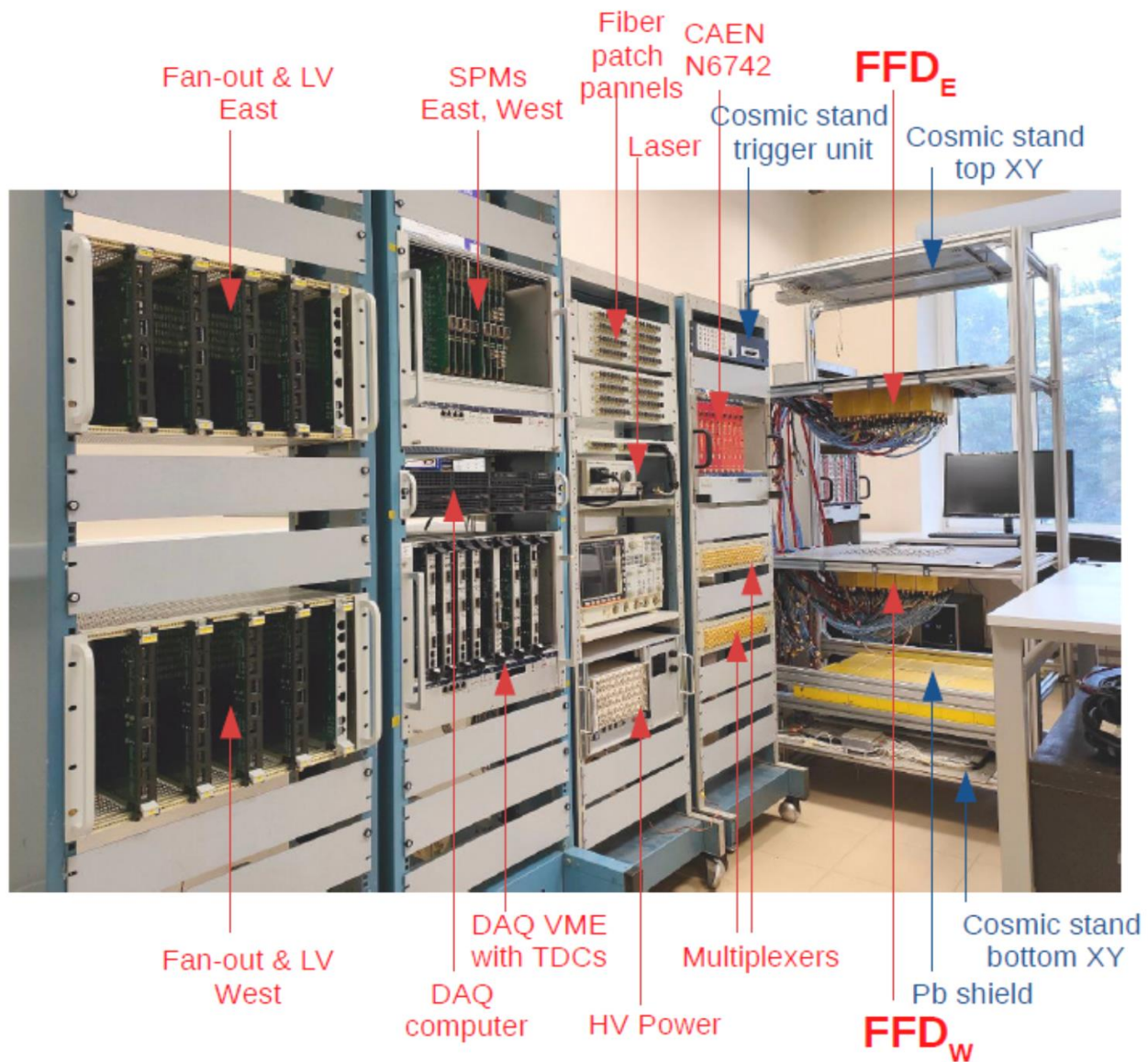

## Main goals of the tests

- integrated long-term test of all the systems
- test of all the components before installation in MPD
- time synchronization of modules in FFD-E, FFD-W

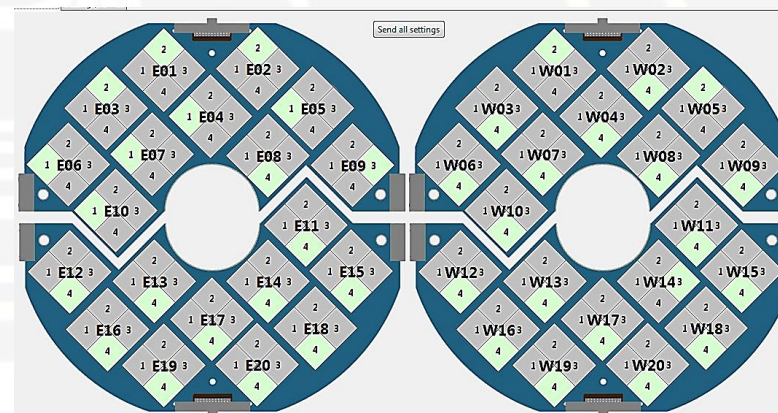

The Detector Control System (DCS) is built using client-server architecture and it includes control and monitoring of all FFD subsystems

# Conclusion

---

- ✓ **The FFD and its electronics have been created with the required characteristics to provide a start signal for the TOF detector and reliable fast trigger for the nuclear collision in the center of MPD**
- ✓ **All modules are assembled and tested**
- ✓ **Laser system is done**
- ✓ **Test stand – done**
- ✓ **Software under development**
- ✓ **FFD DCS – almost done**
- ✓ **All FFD subsystems are currently undergoing final testing before the detector is installed in MPD, which is scheduled for this year.**



**THANK YOU FOR YOUR ATTENTION**

# Fan-out & LV - LVM

Fan-out - A Micrel chip SY58608U is used as a fan-out 1:2. It provides propagation delay  $< 300$  ps, rise/fall time  $< 100$  ps and it processes signals as fast as 2 GHz. The T0U output connectors for DAQ for TOF are Molex 76105-0585.

The Power Supply Block provides three independent voltages to supply detector FEE, those supplies are monitored and controlled with high precision. Each channel could be switched on/off independently.

- The Negative voltage channel provides current up to 100 mA at -7.3V. The Positive channels provide current up to 150 mA in a voltage range from 4.0V to 8.0V and could be adjusted with 1mV step.
- 12 bit DAC is used to adjust the voltage
- The channel output voltages and currents are read back by 12-bit ADC.
- The communication to the detector control

system is done via RS serial link.



# SPM and VPM

- Developed a custom crate based on VME mech. and wiener custom power supply
- Based on Cyclone 10GX FPGA (10CX220YF780E5G)
- Delay chip – SY89296U – programmable delay line, 10ps step, vary from 3.2ns to 14.8ns, <10ps total jitter and <1ps random jitter.
- Molex connector for signal (170465-0002) and for fast backplane signals
- Comparator chips - ADCMP561BRQ – 1.5GHz equivalent input rise time bandwidth 700ps min pulse width, 75ps prop.delay
- TTL 50 ohm driver - SN74LVT125PWR
- 2 optical link – UDP
- All signal traces are equalized
- Backplane drivers - SY58605U

