

Detecting Antiprotons with Submicrometric Spatial Accuracy

Markus Münster
TIPP2026

1. Motivation
2. Antiproton Detection
3. Resolution
4. System Architecture

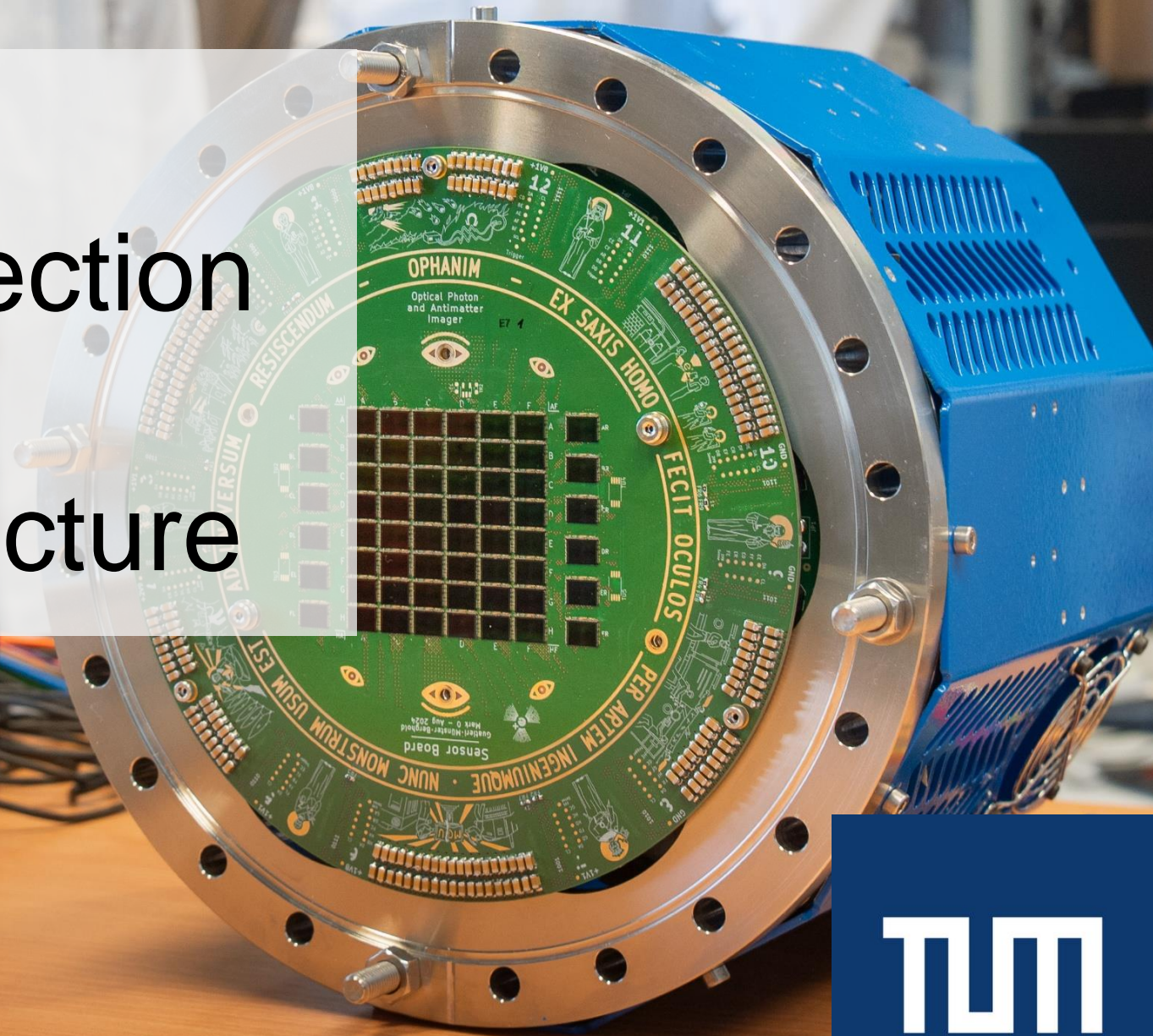

1. Motivation
2. Antiproton Detection
3. Resolution
4. System Architecture

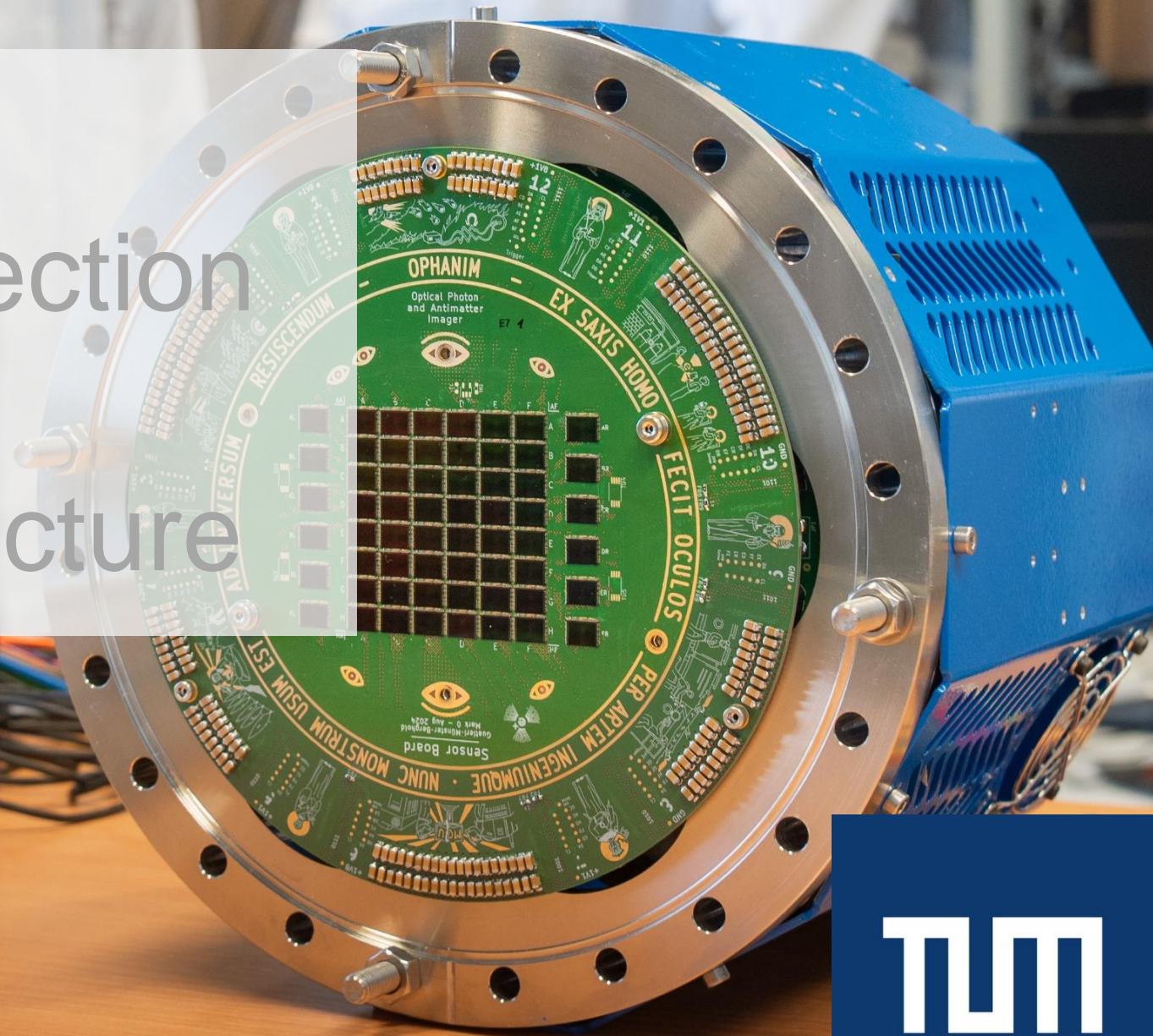

Motivation: Experimental Setup of AEgIS

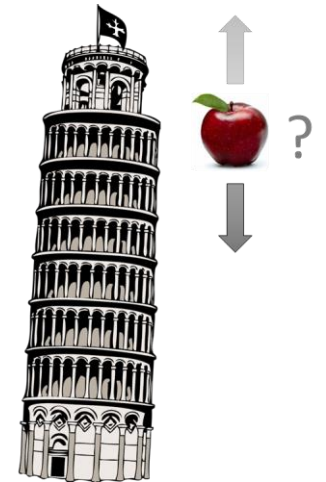
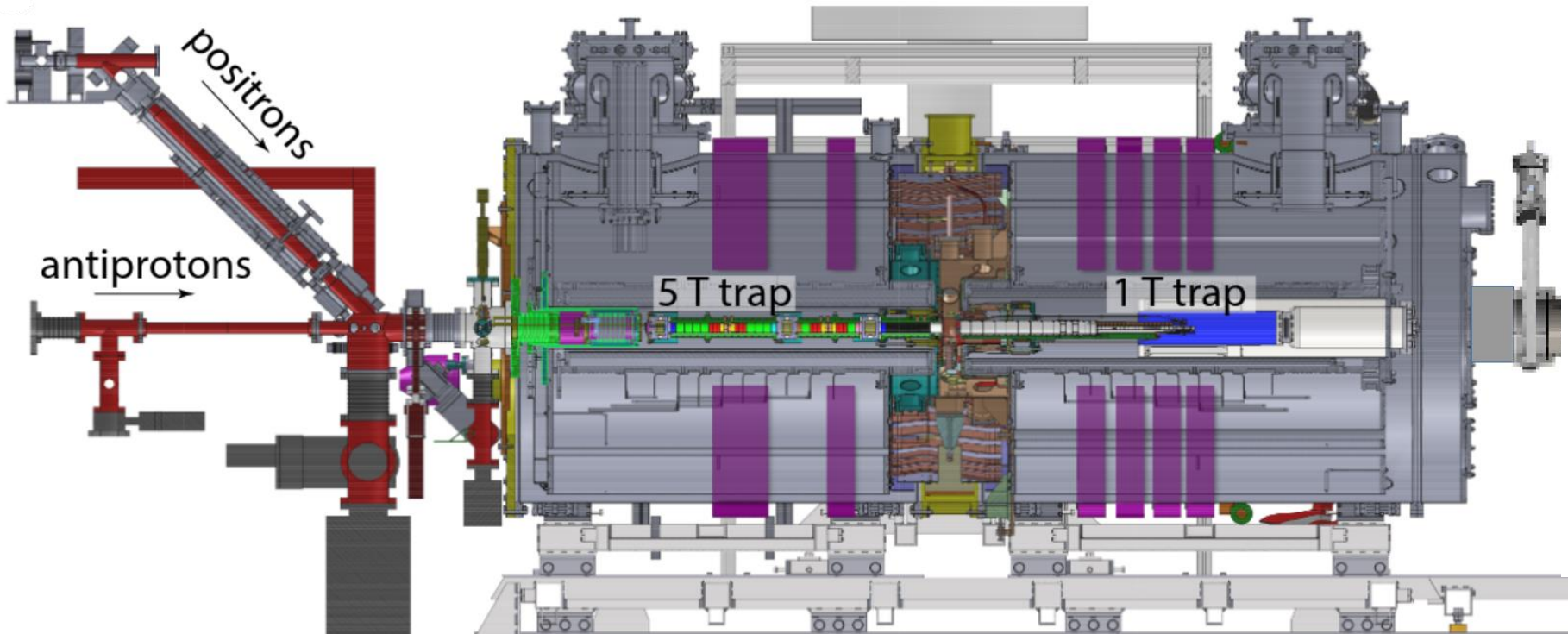

Motivation: Experimental Setup of AEgIS

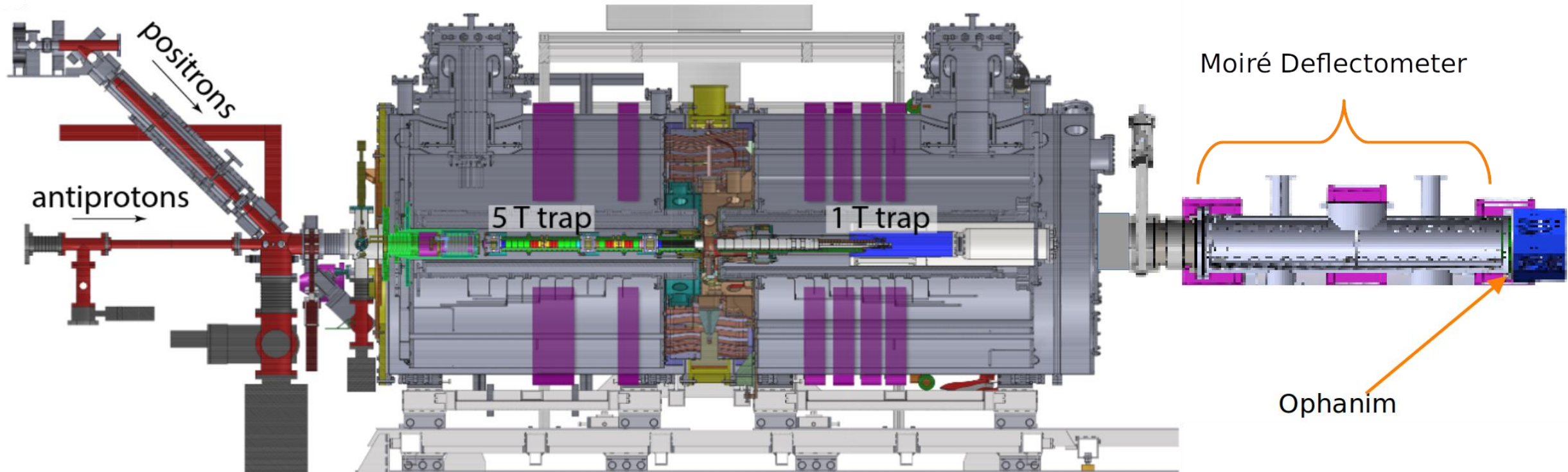

Motivation: Experimental Setup of AEgIS

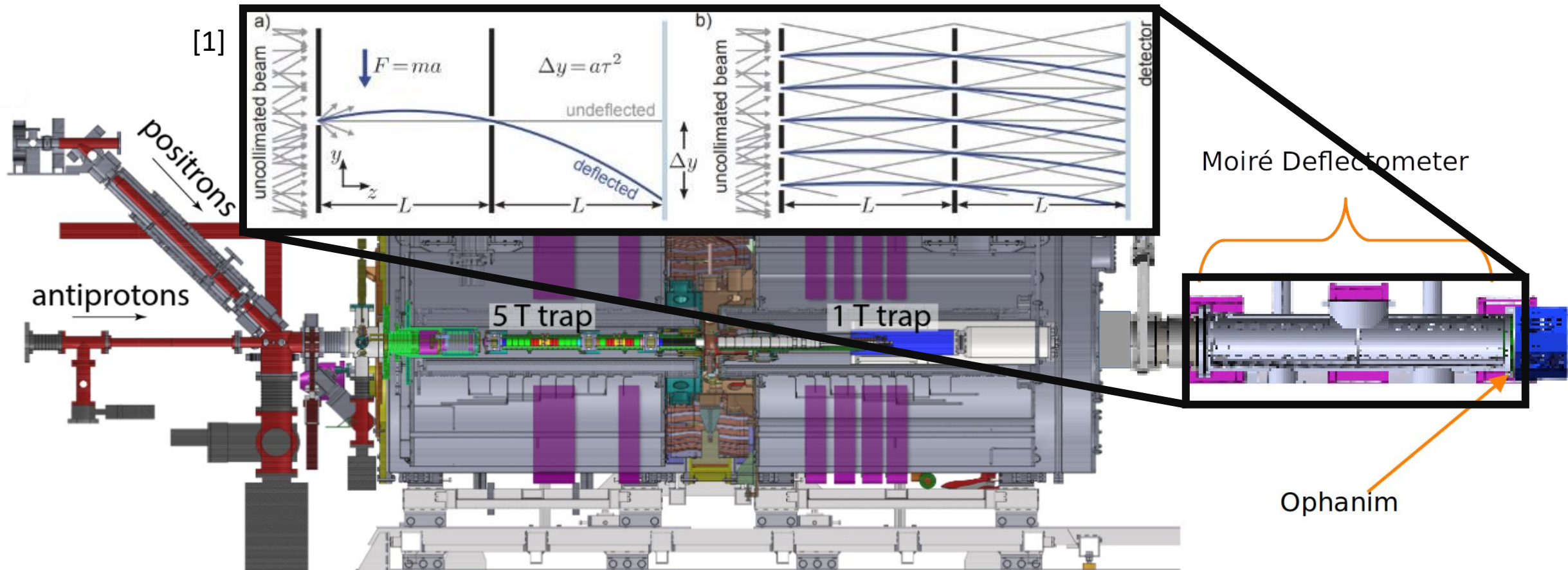

[1] Aghion, S., Ahlén, O., Amsler, C. *et al.* A moiré deflectometer for antimatter. *Nat Commun* 5, 4538 (2014).

What is the OPHANIM Detector?

O_{ptical} P_Hoton and A_Ntimatter I_Mager

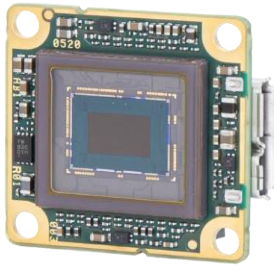

X 60 =

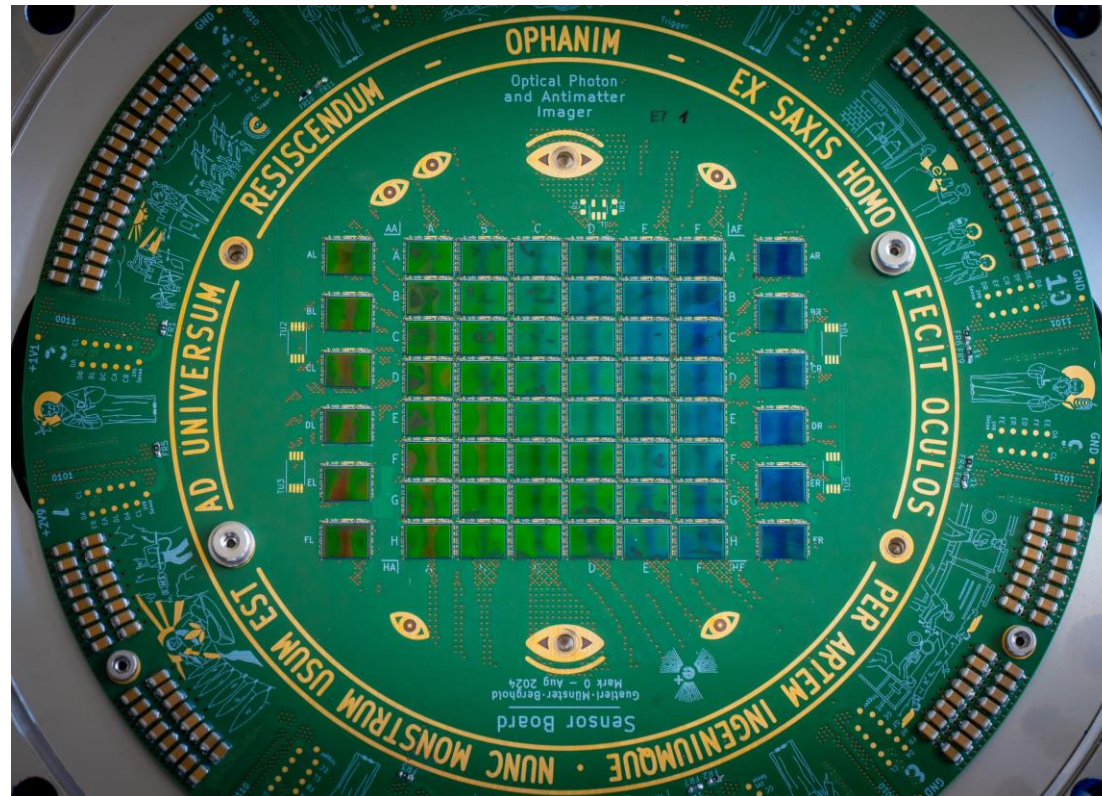

OPHANIM Detector

- 3852 MP
- Pixel Size: $0.8 \times 0.8 \mu\text{m}^2$
- $55.32 \times 55.96 \text{ mm}^2$
- 66% active area

Sony IMX686:
64.2 MP CMOS
Smartphone Camera Sensor

1. Motivation
2. Antiproton Detection
3. Resolution
4. System Architecture

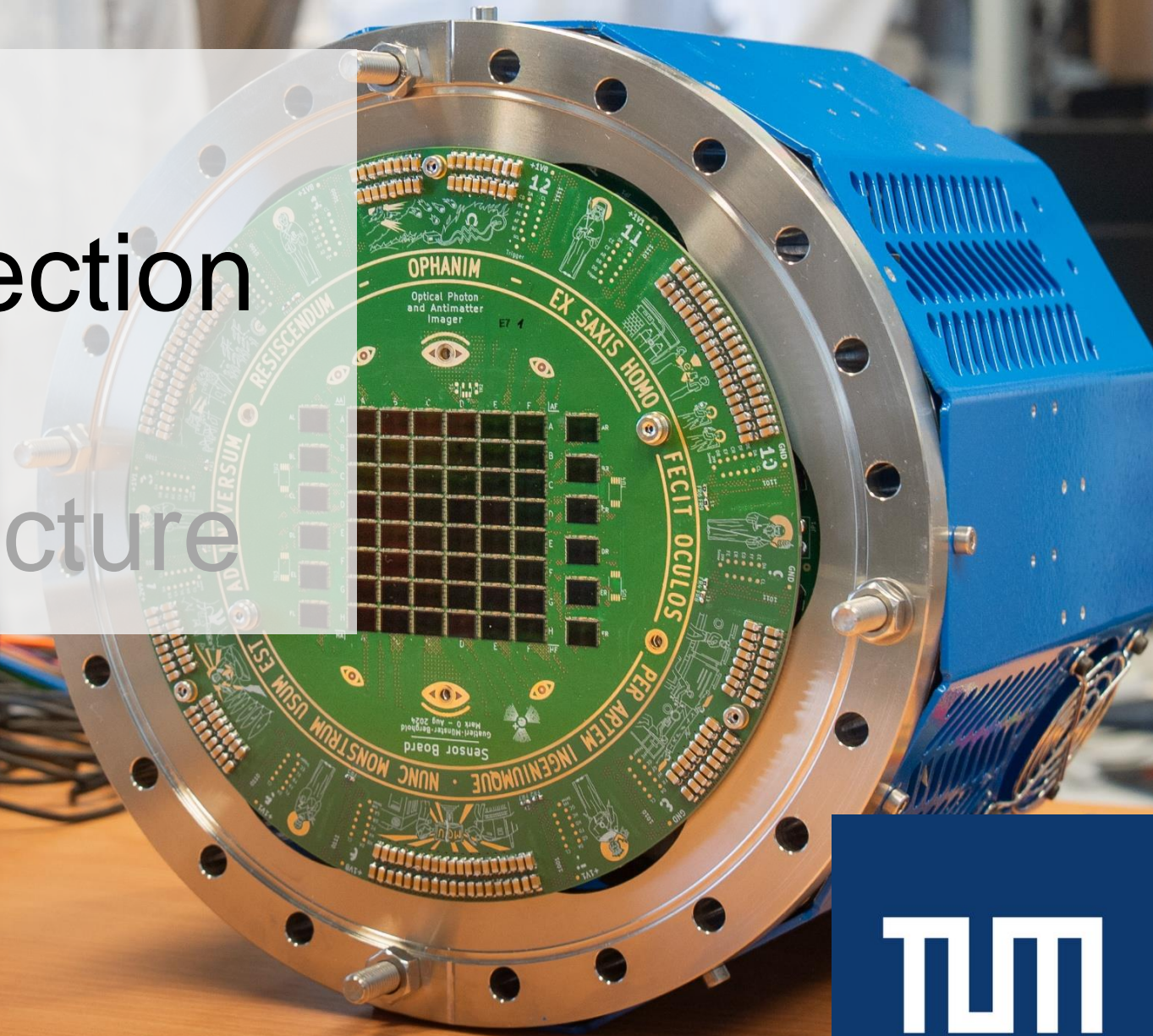

Antiproton Detection

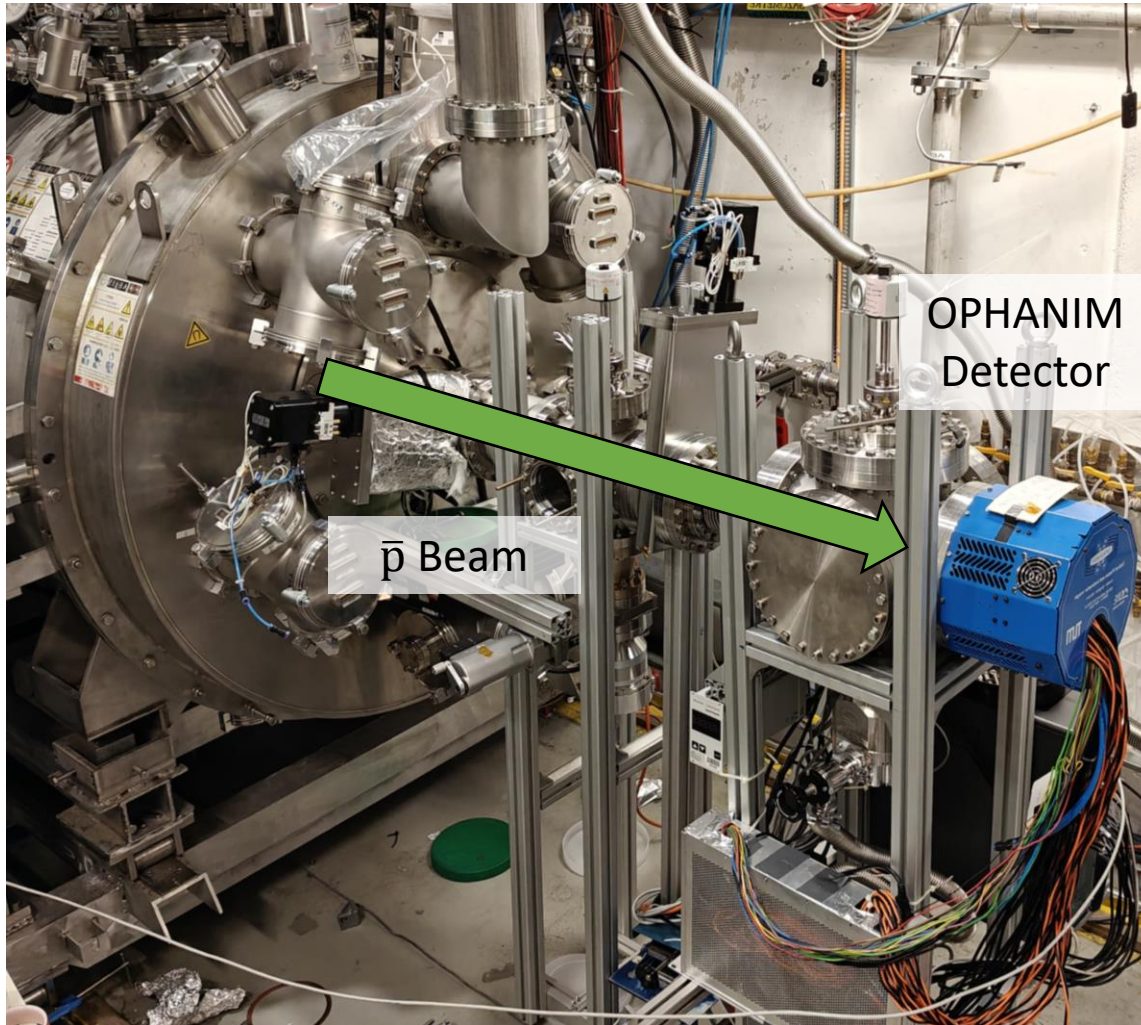

Antiproton Detection

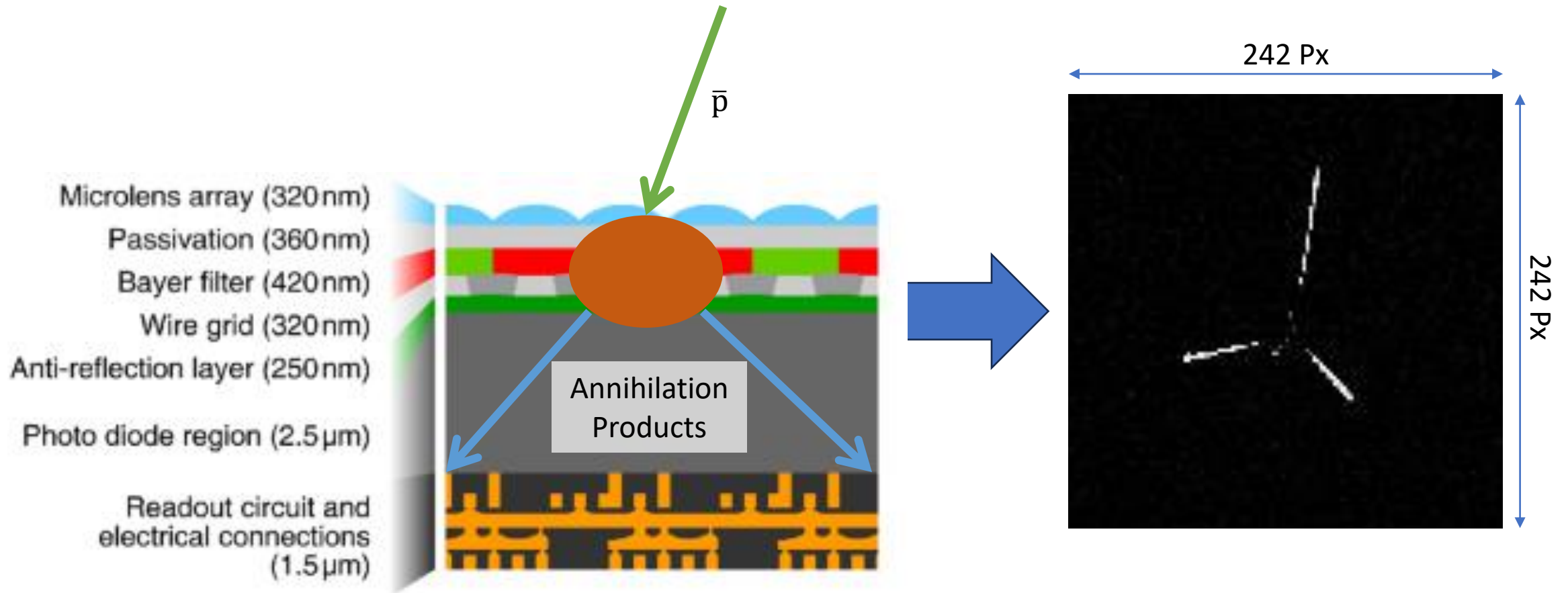

1. Motivation
2. Antiproton Detection
- 3. Resolution**
4. System Architecture

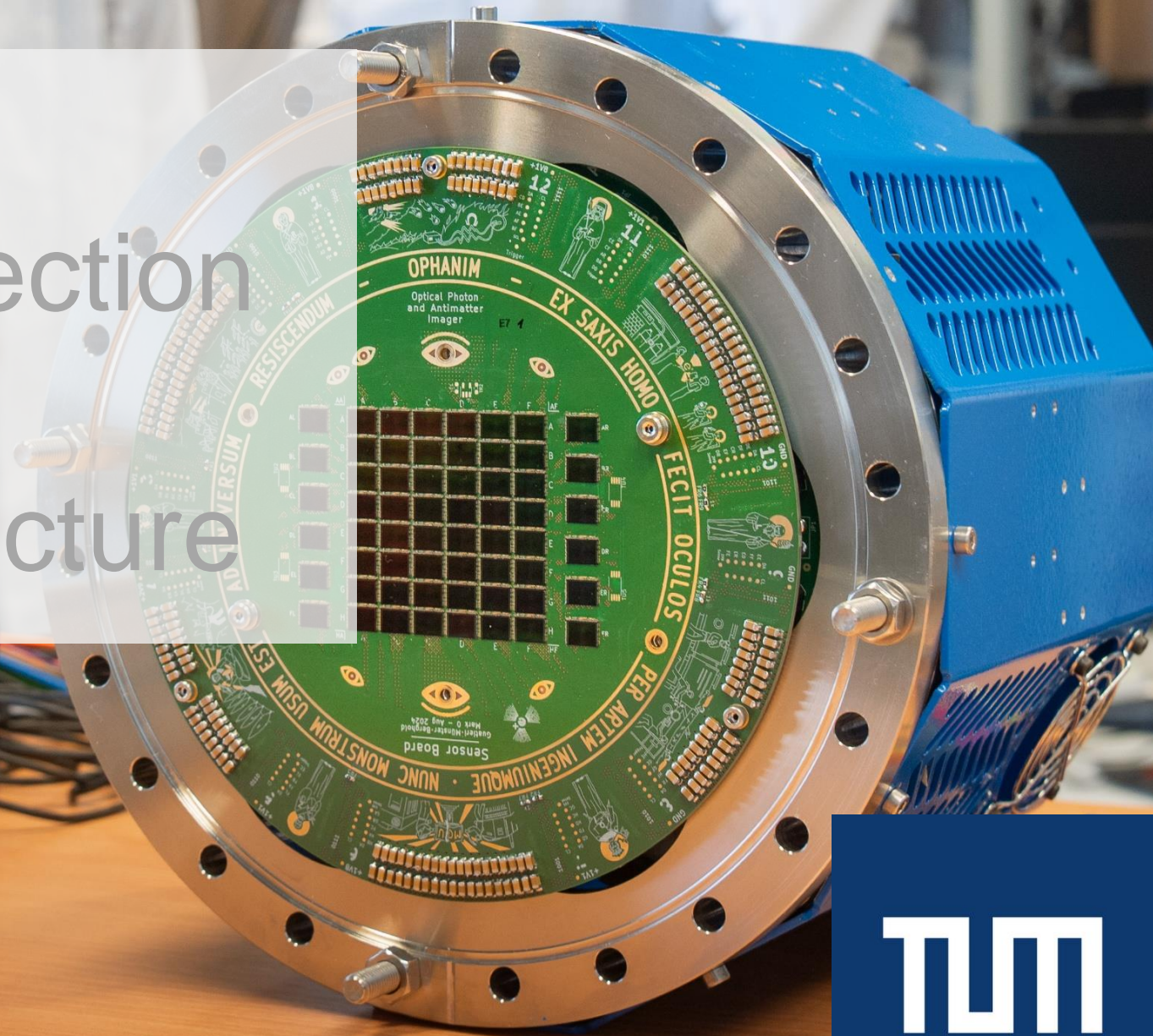

Vertexing

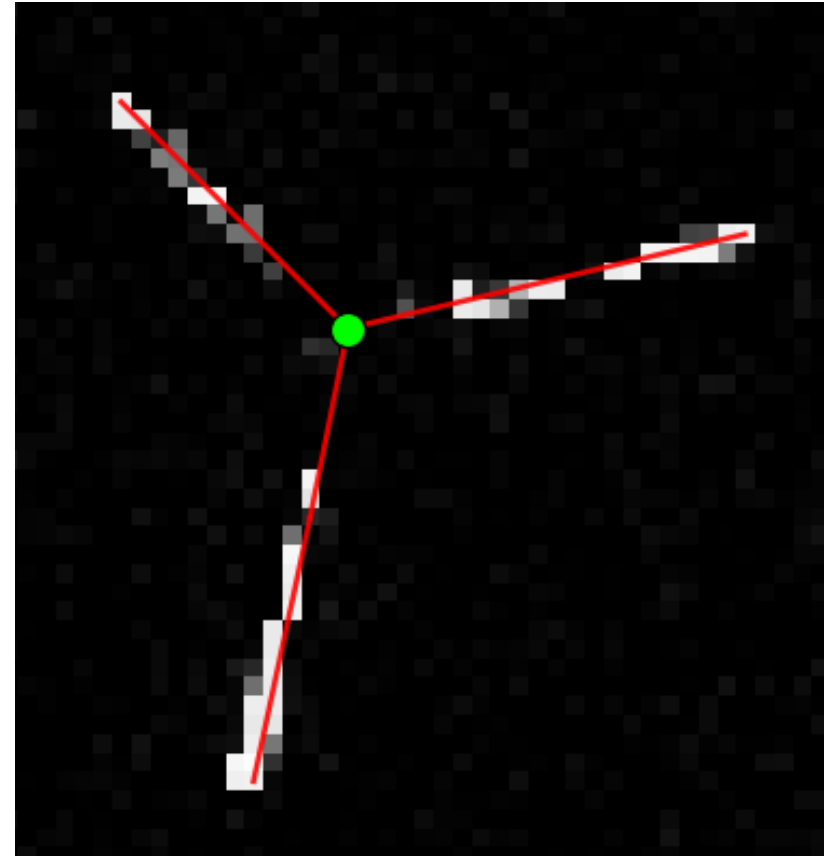
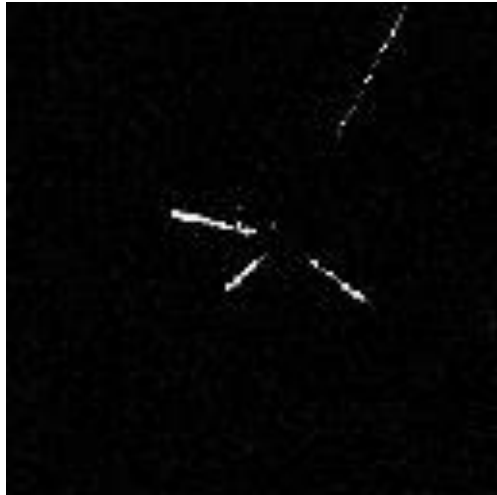
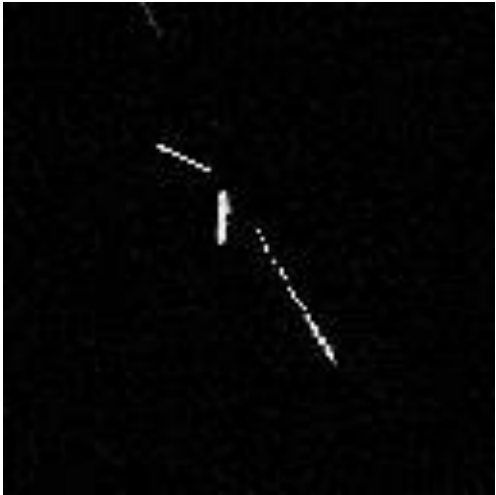

Quantifying the Resolution

Pitch: 100 μm
Openings: 40 μm

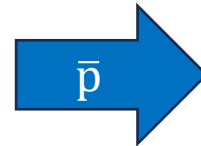
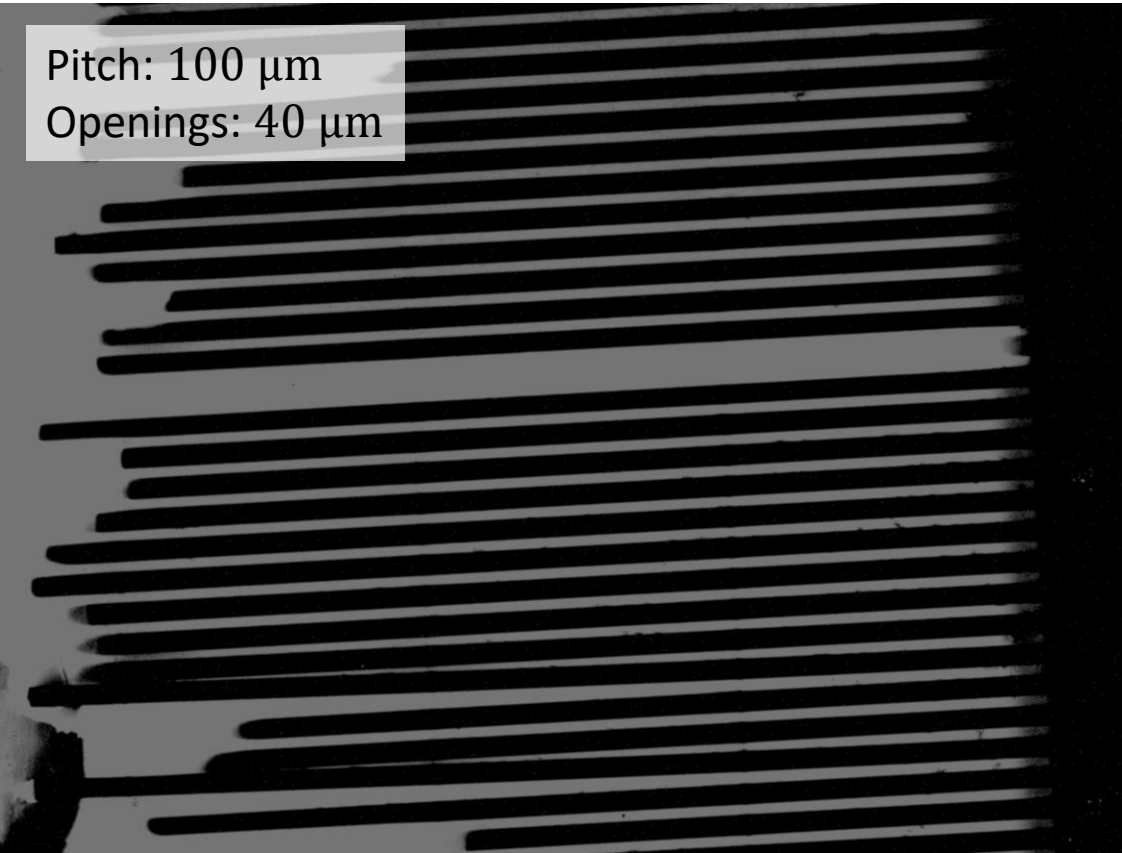

Quantifying the Resolution

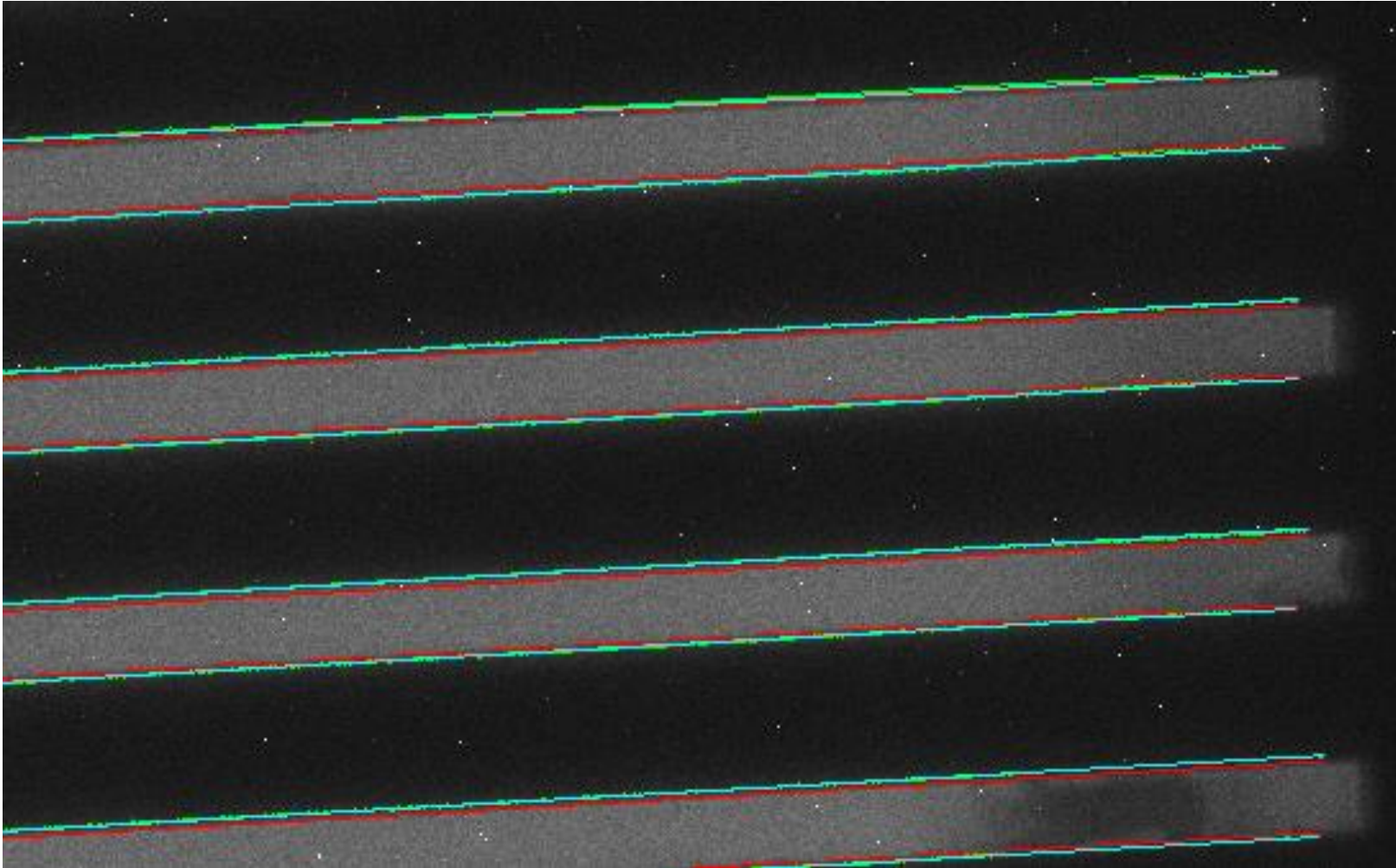

Quantifying the Resolution

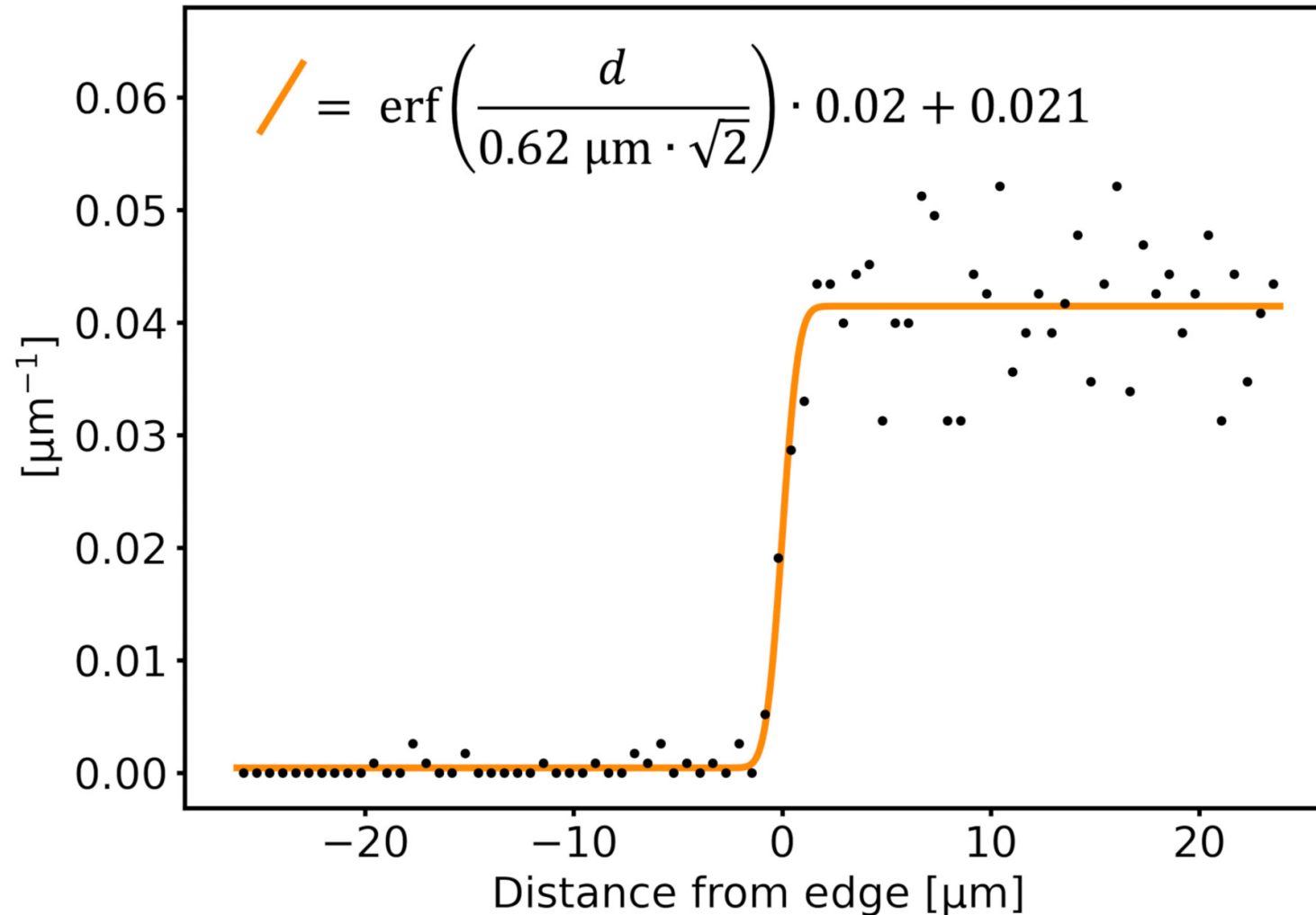

Previously with Timepix3:

22 μm [2]

Resolution:
 $0.62^{+0.40}_{-0.22} \mu\text{m}$

[2] H. Holmestad, Data analysis, simulations, and reconstruction of antiproton annihilations in a silicon pixel detector. Phd thesis, University of Oslo, department of Physics 2018.

1. Motivation
2. Antiproton Detection
3. Resolution
4. System Architecture

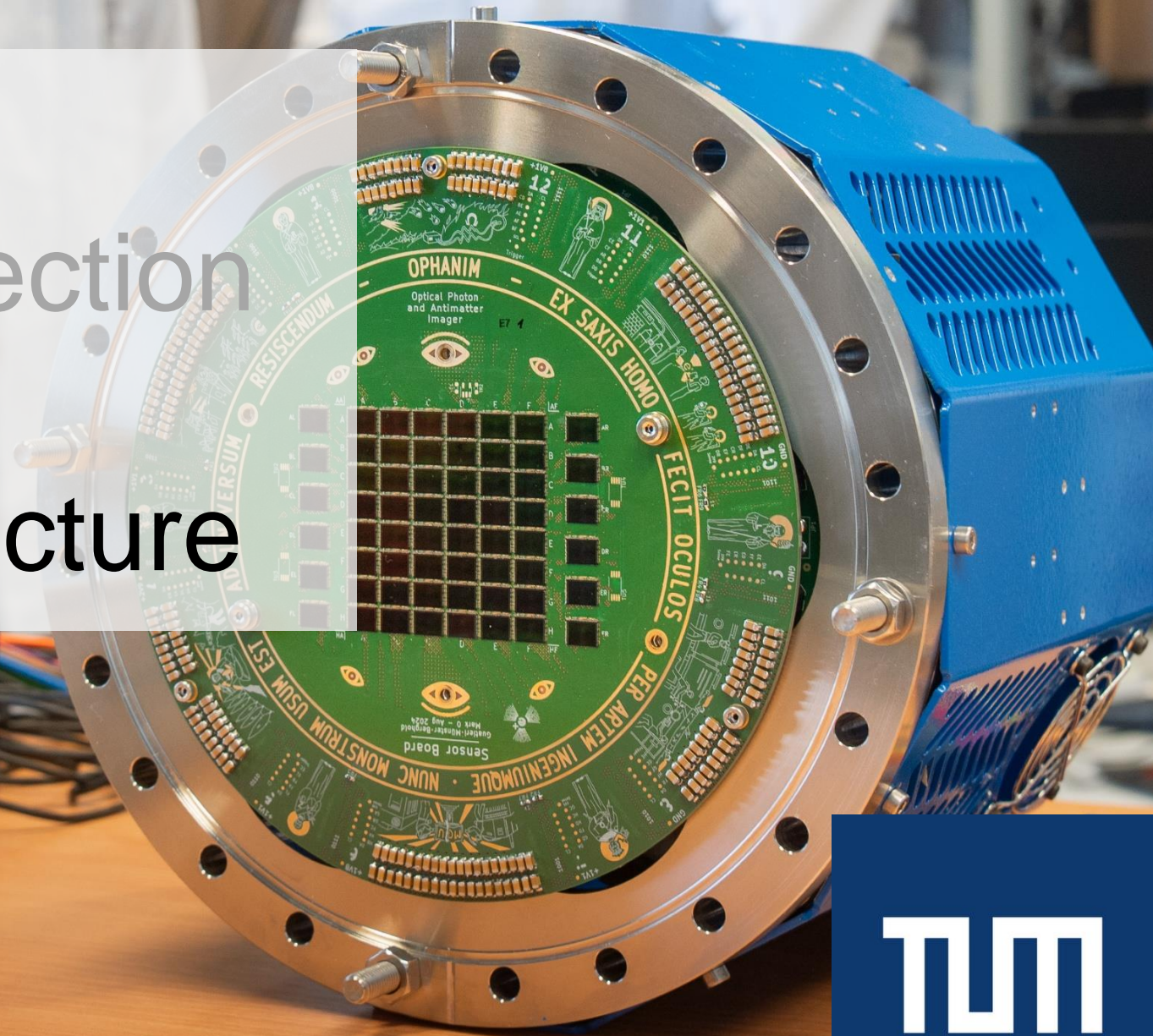

Hardware Overview

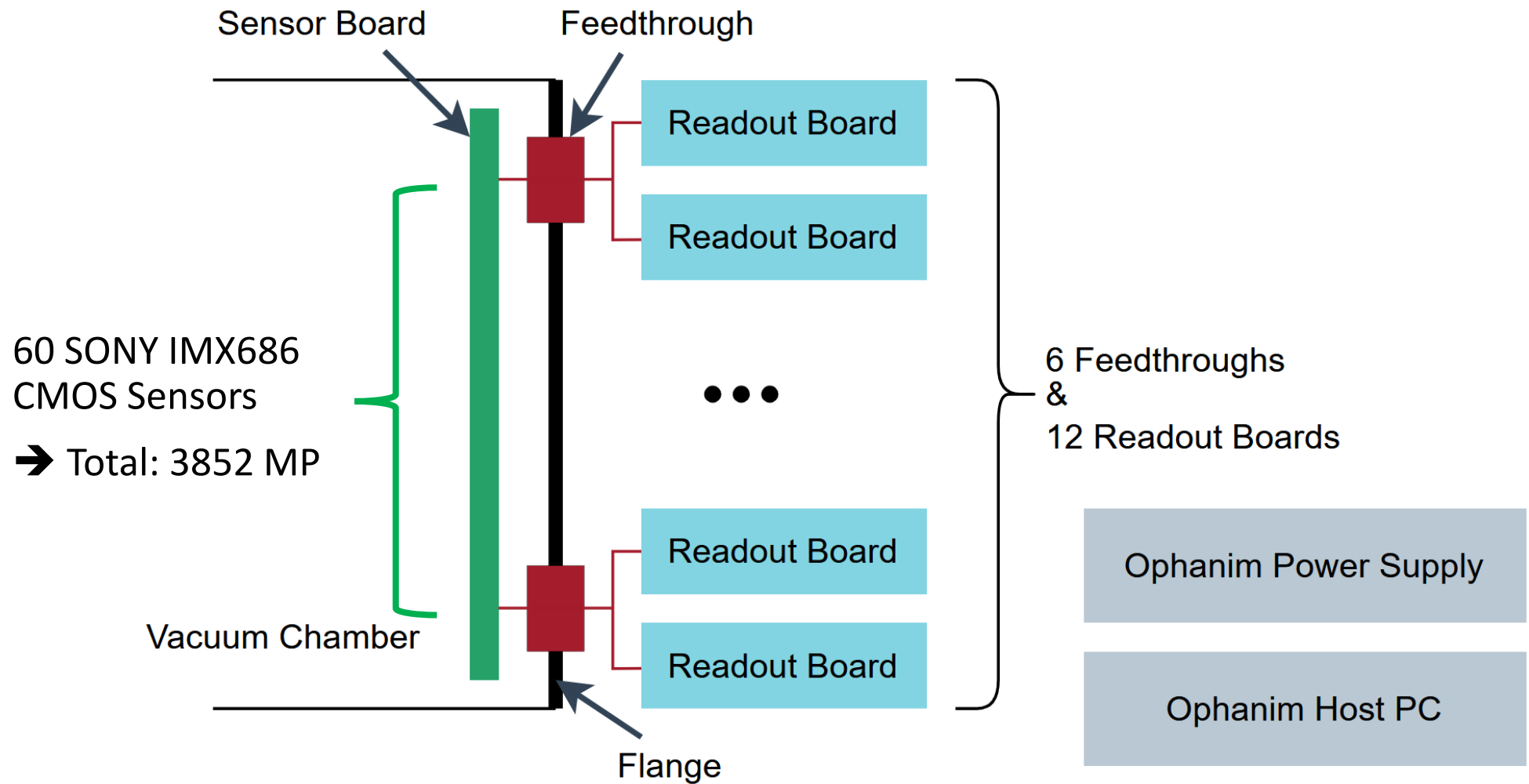

OPHANIM Data Bus

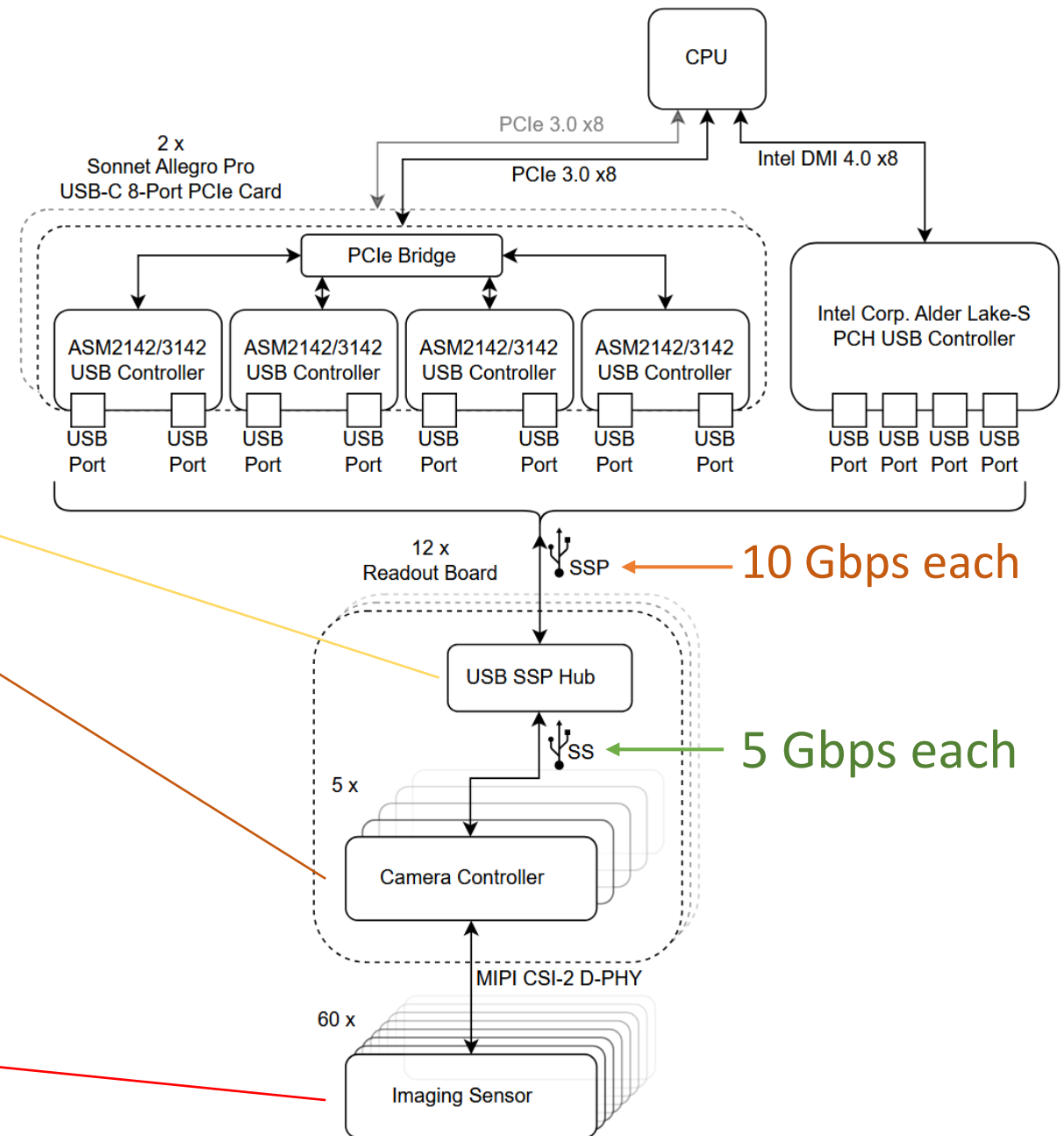
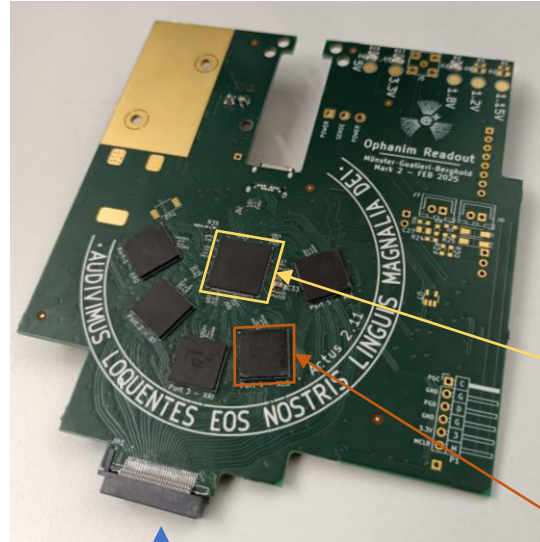

Data Streaming

actual Payload

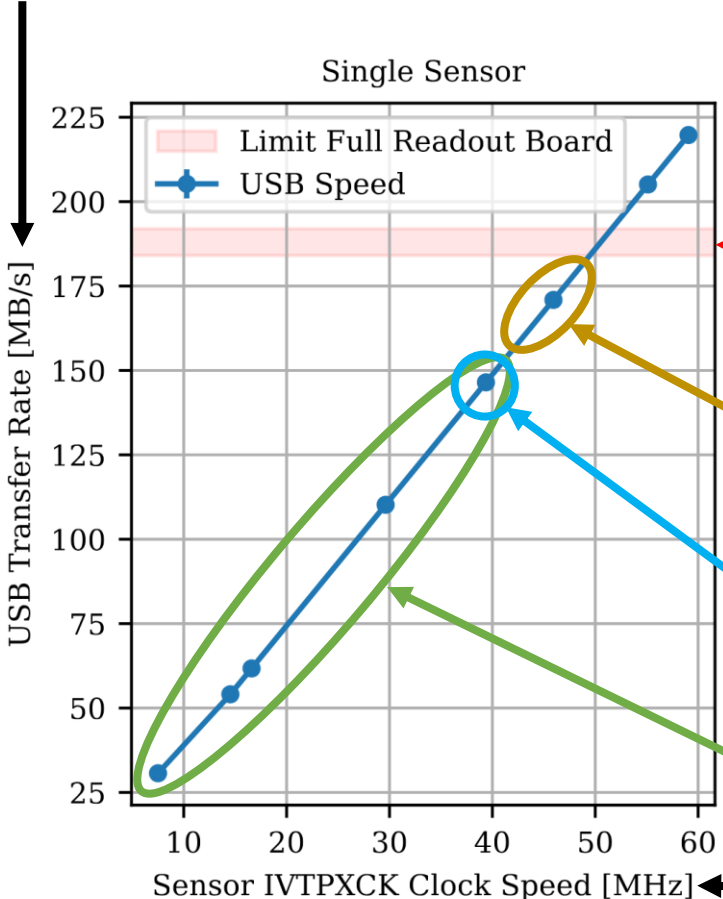

10 Gbps
 ⇔
 920 to 960 MB/s → Shared by 5 Devices → 184 to 192 MB/s per device of usable Payload

Possible with improved USB-PCIe Interface

146 MB/s per device
 → ca. 730 MB/s on Hub ⇔ USB Controller Connection
 → ca. 8.76 GB/s in total

Can be achieved with entire detector with given hardware

← Internal Sensor Clock determines the Pixel-Readout Frequency

Acquisition Procedure

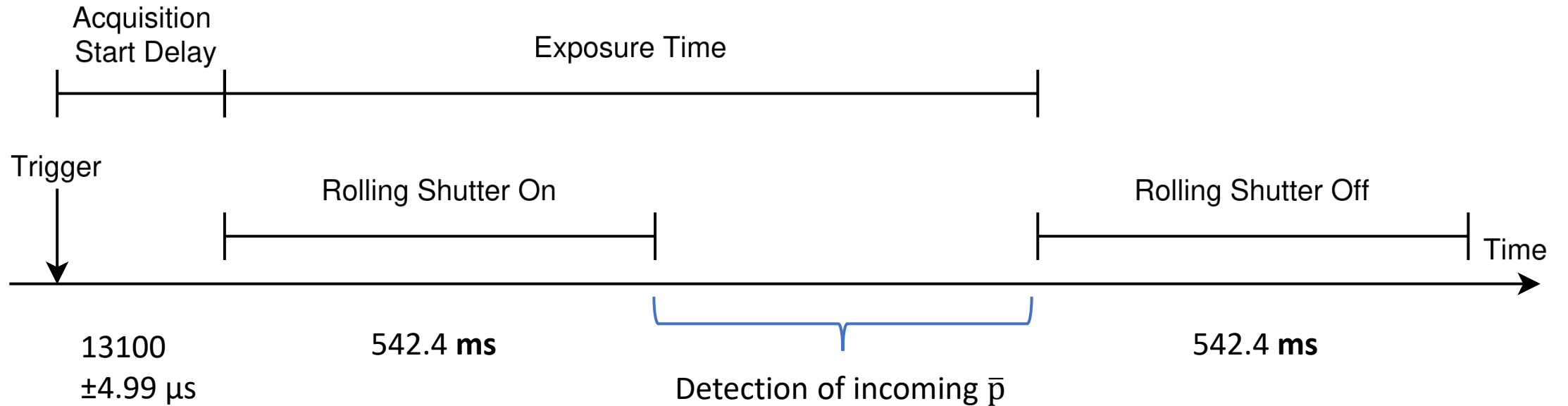

- Image Streaming with up to ca. 1.8 FPS possible with current Hardware
- At AEGIS: Single images with long exposure times (order of 10^1s)

Outlook

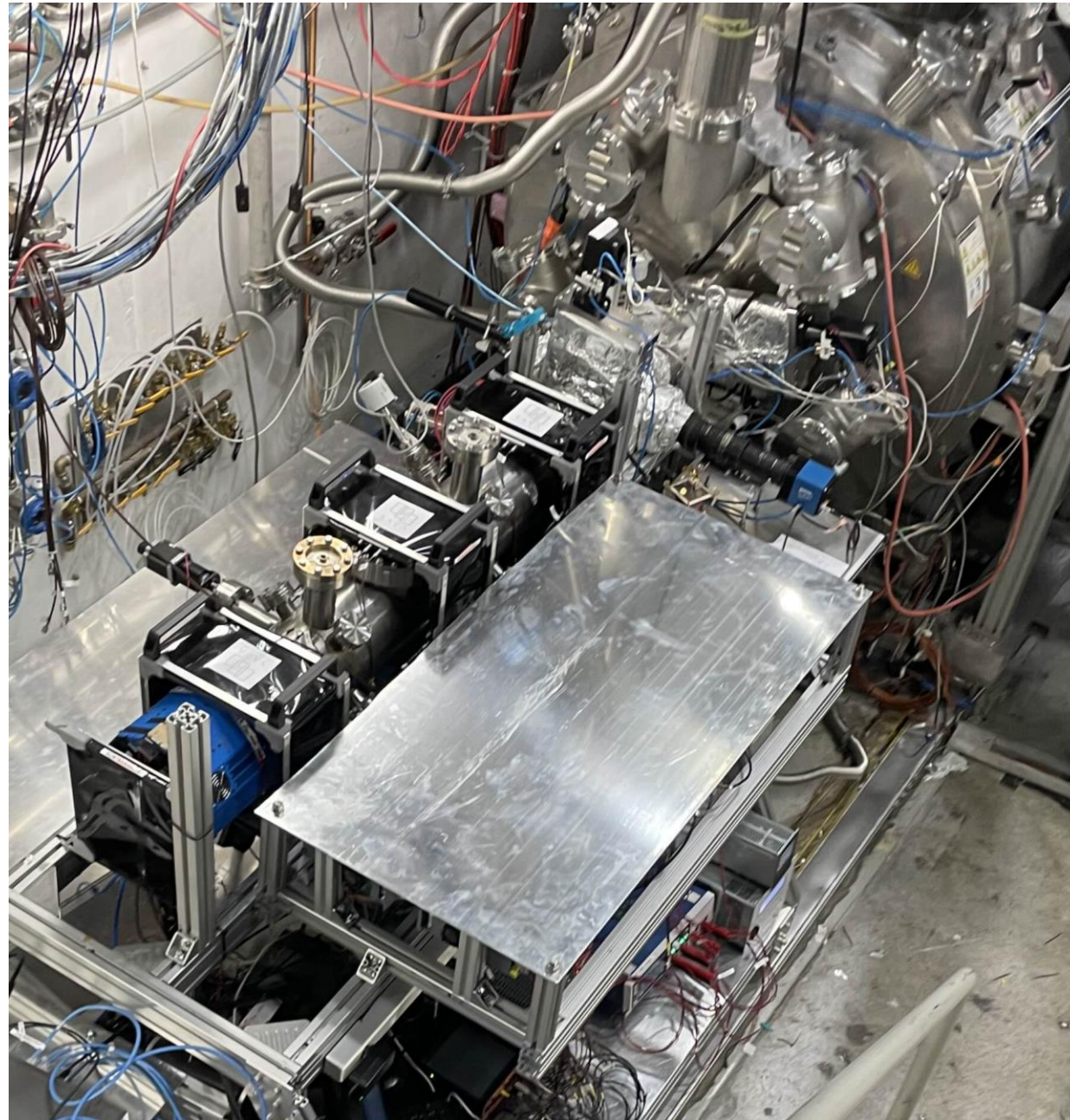

Outlook

- Time Sensitivity
- Particle Tracker

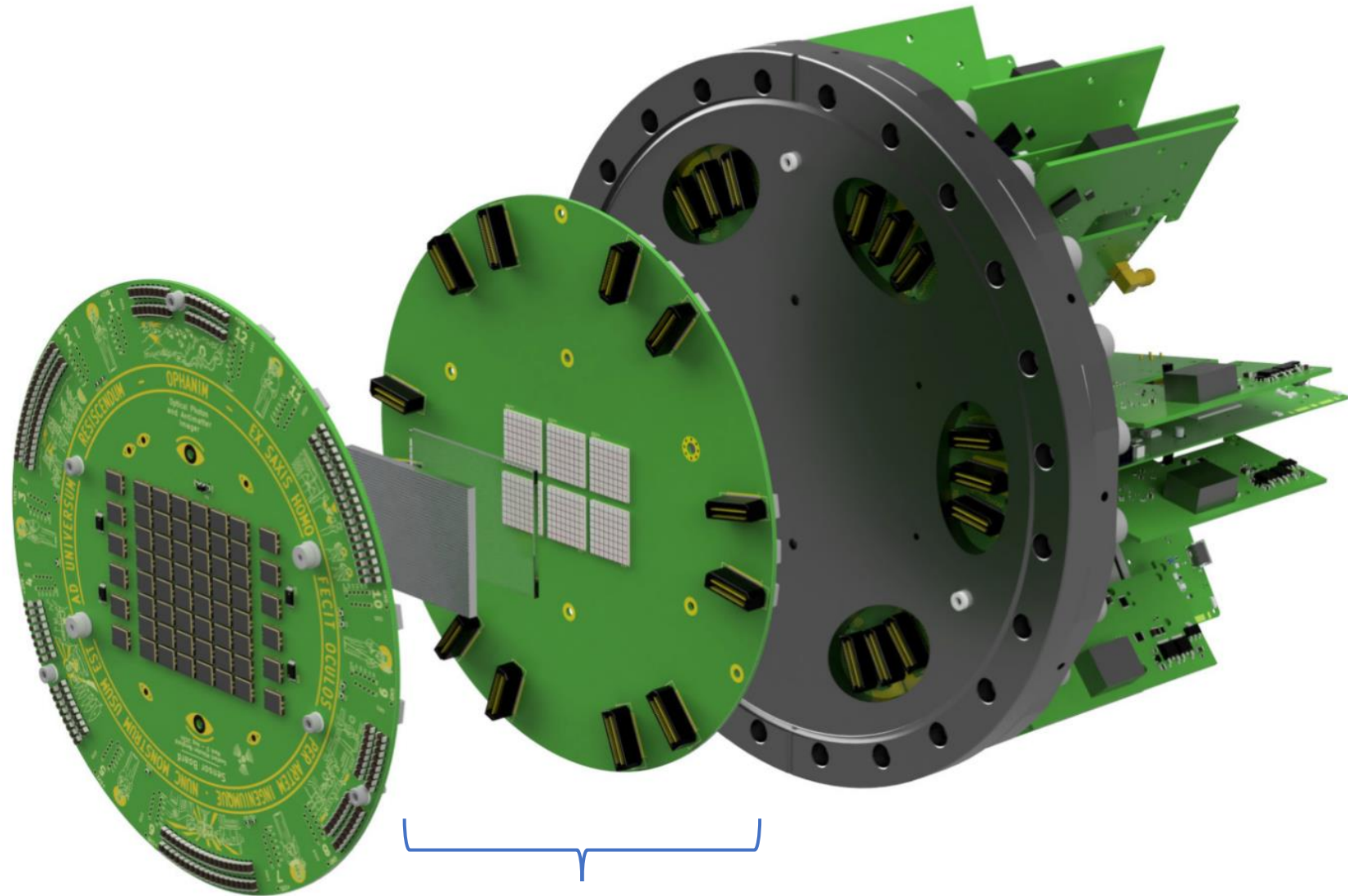

Additional MPPCs

Acknowledgement

Dr. Francesco Guatieri
Michael Berghold
Dr. Ruggero Caravita
Prof. Dr. Christoph Hugenschmidt



Paper: Real-time antiproton annihilation vertexing with submicrometer resolution

