

# Status of the ATLAS Tile Calorimeter during LHC Run 3

Mattia Soldani

CERN  
mattia.soldani@cern.ch

on behalf of the ATLAS Collaboration

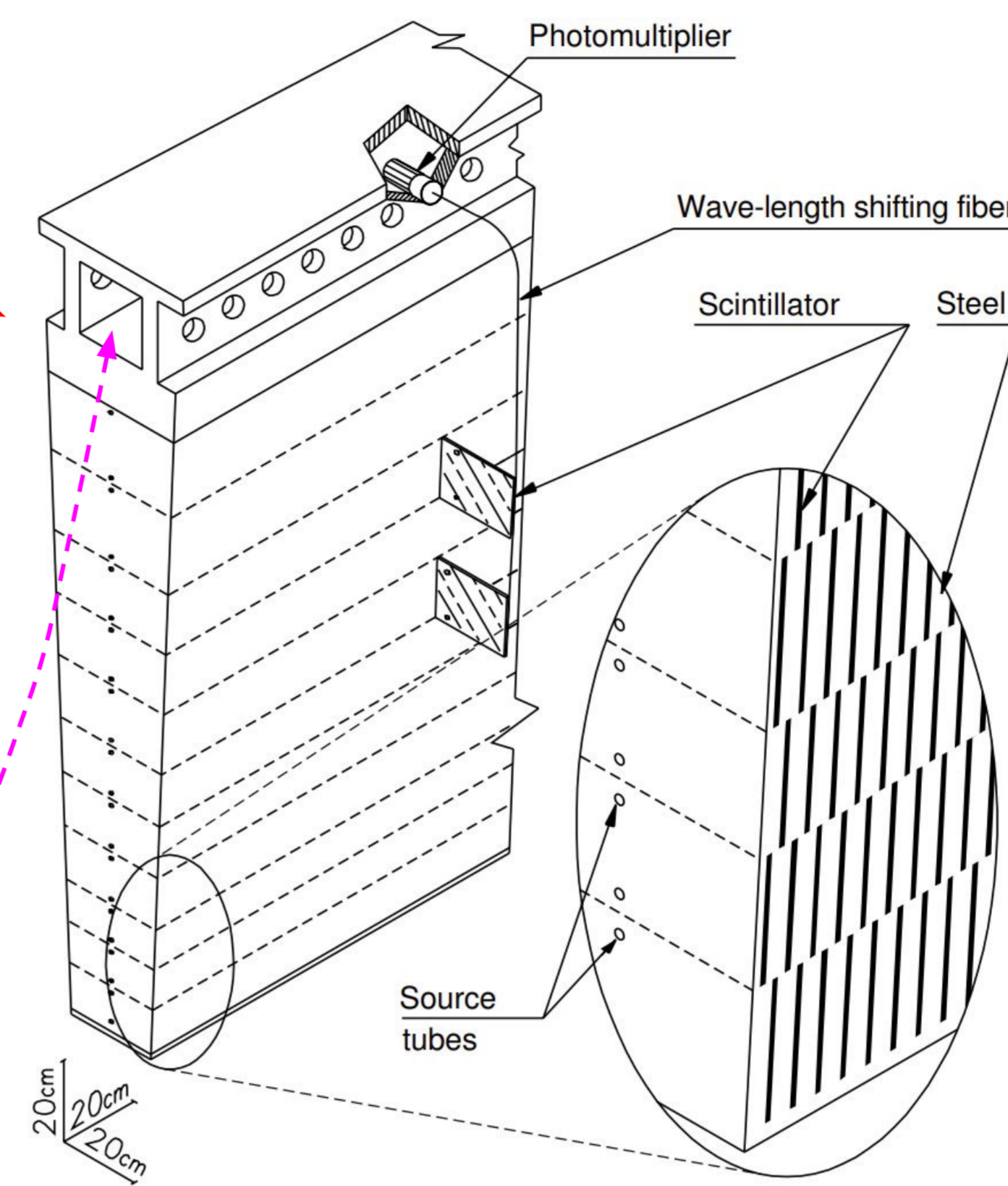
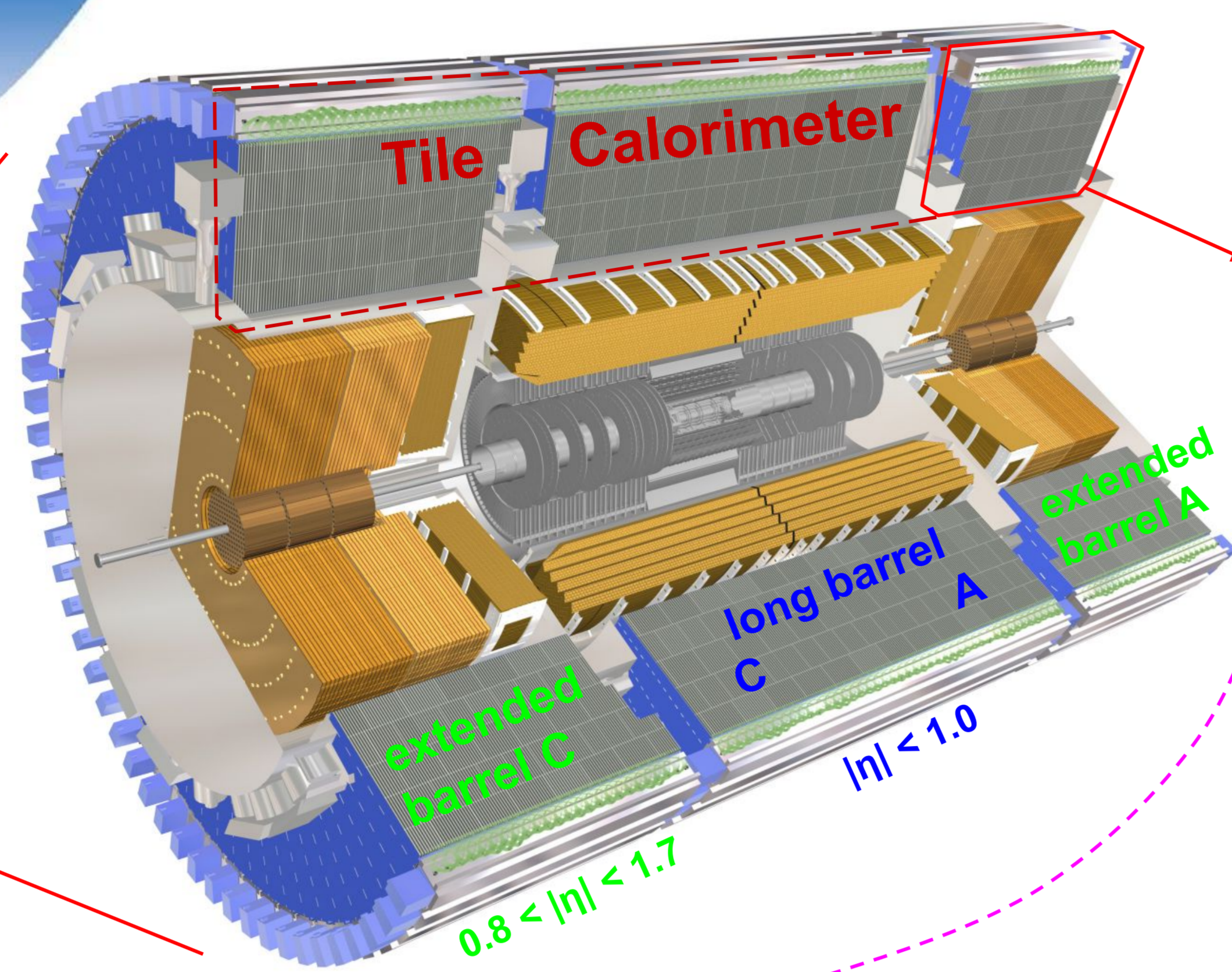

Central hadronic calorimeter: sampling, steel and plastic scintillator with

- Read out by photomultiplier tubes (PMTs)
- Tiles orthogonal to radius
- Transverse segmentation:  $\Delta\eta \times \Delta\phi \sim 0.1 (0.2) \times 0.1$  in the inner (outer) layers
- 3-fold radial segmentation
- Hadron energy resolution:

$$\frac{50\%}{\sqrt{E/\text{GeV}}} \oplus 3\%$$

⇒ Jets, isolated hadrons, hadronically decaying taus, missing transverse energy, contribution to calorimetric trigger

## Readout

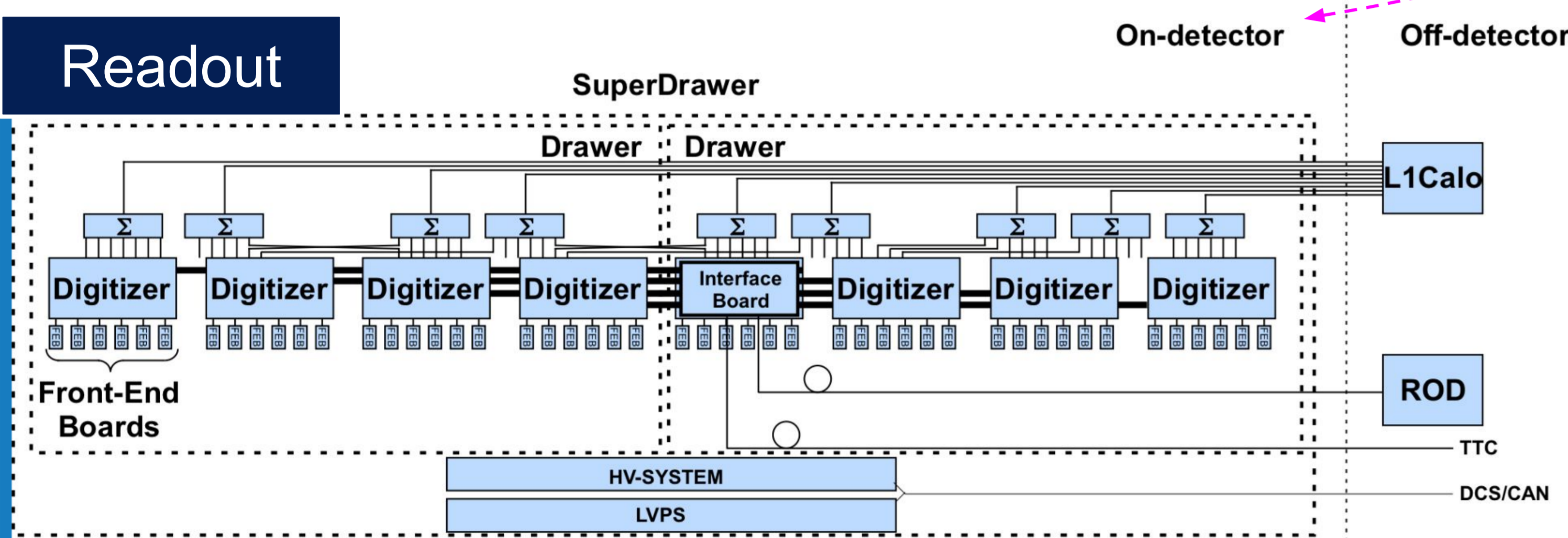

- O(10,000) PMTs, 2 for each cell ⇒ 1 readout channel per PMT
- Front-end\* ⇒ Shaped signal to the ADCs: sampling @ 40 MHz
- Digital waveform (7 samples) retrieved from on-board pipeline if triggered (Level1) ⇒ Sent off-detector
- Waveform analysis\*\* ⇒ Cell amplitude and time stored for analysis

- \* 3-in-1 front-end board
  1. Dual-gain amplification + shaping
  2. Output to analog adder for trigger
  3. Current integrator for calibration

\*\* Optimal filtering fit algorithm

$$A = \sum_{i=1}^7 [a_i s_i] \quad t = \frac{1}{A} \sum_{i=1}^7 [b_i s_i]$$

• From beamtest data • Waveform samples

## Calibrations

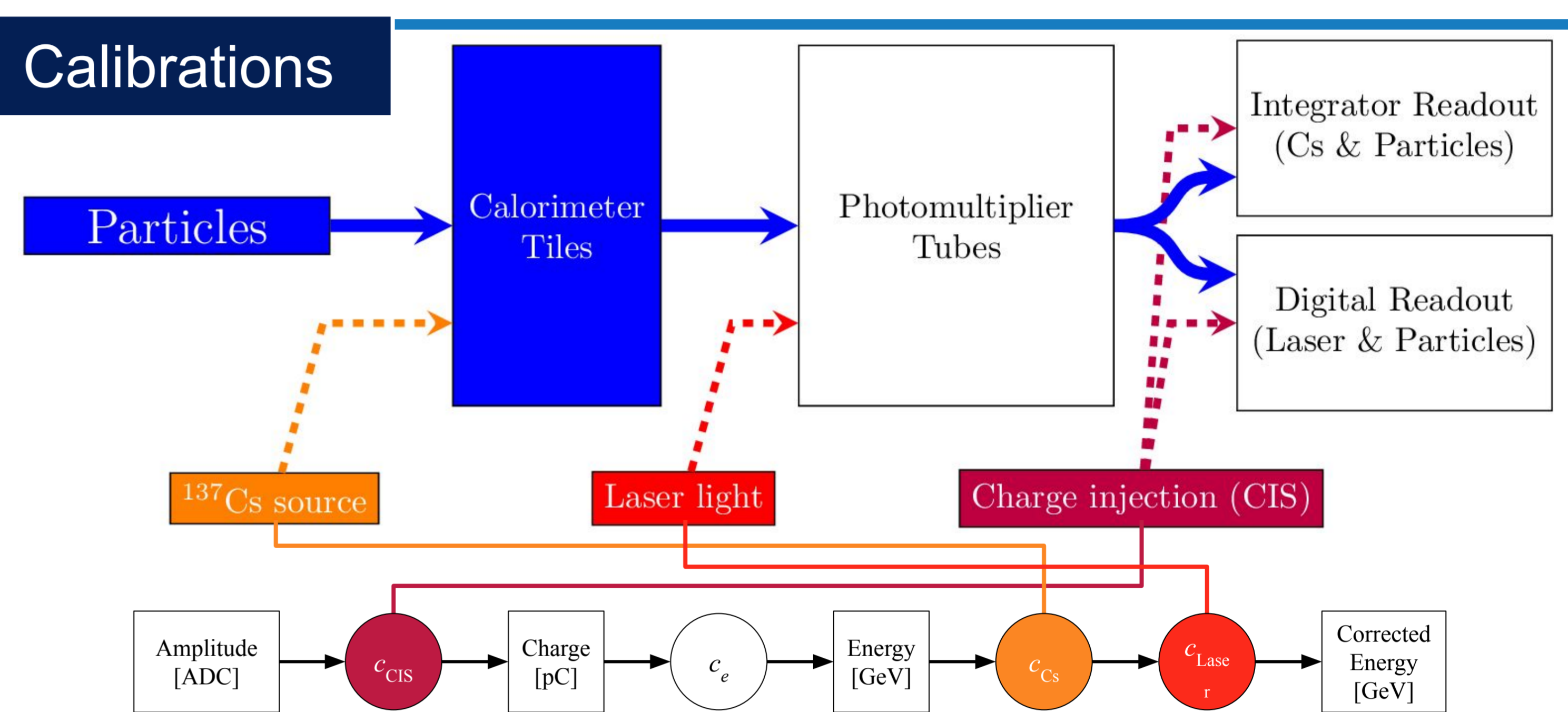

## Isolated muons

- From tracks in reconstructed  $W \rightarrow \mu\nu$
- Figure of merit: energy loss per unit length
- Compared to standard ionisation (MIP) ⇒ Calibration of the e.m. scale cell-by-cell, across the entire calorimeter volume

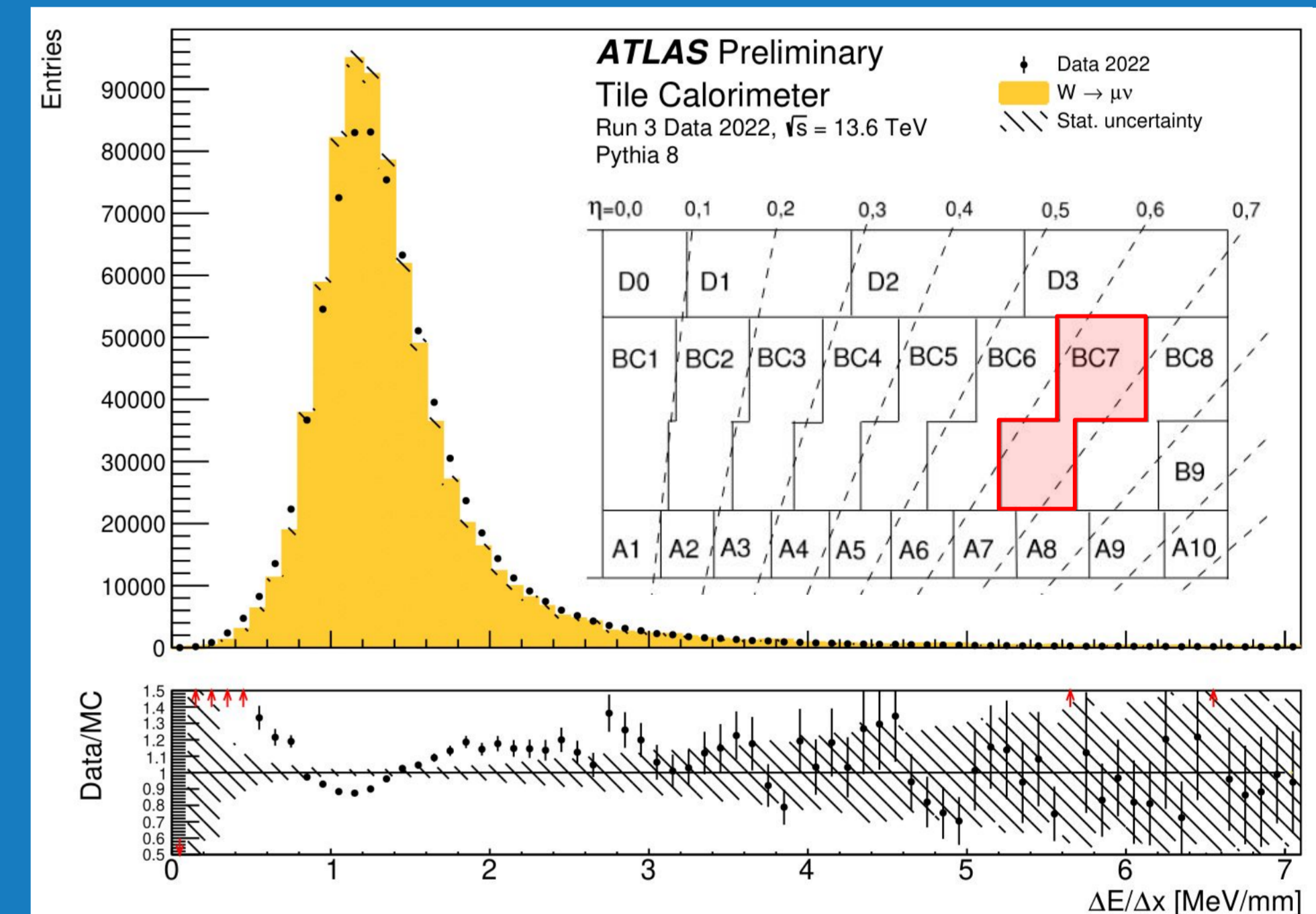

## Cell timing performance

- Estimated from cell time wrt global event time in  $p_T > 20$  GeV/c multi-jet events
- Corrections with laser calibration data
- Figure of merit: time resolution
  - Cell time distribution ⇒ gaussian sigma
  - Decrease with cell energy expected due to statistical error  $\propto 1/\sqrt{E}$  and electronic noise  $\propto 1/E$
  - EB cells have larger cross section ⇒ worse resolution
- Better time alignment and resolution ⇒ better performance of
  - The optimal filtering algorithm\*\*
  - Time-of-flight measurement

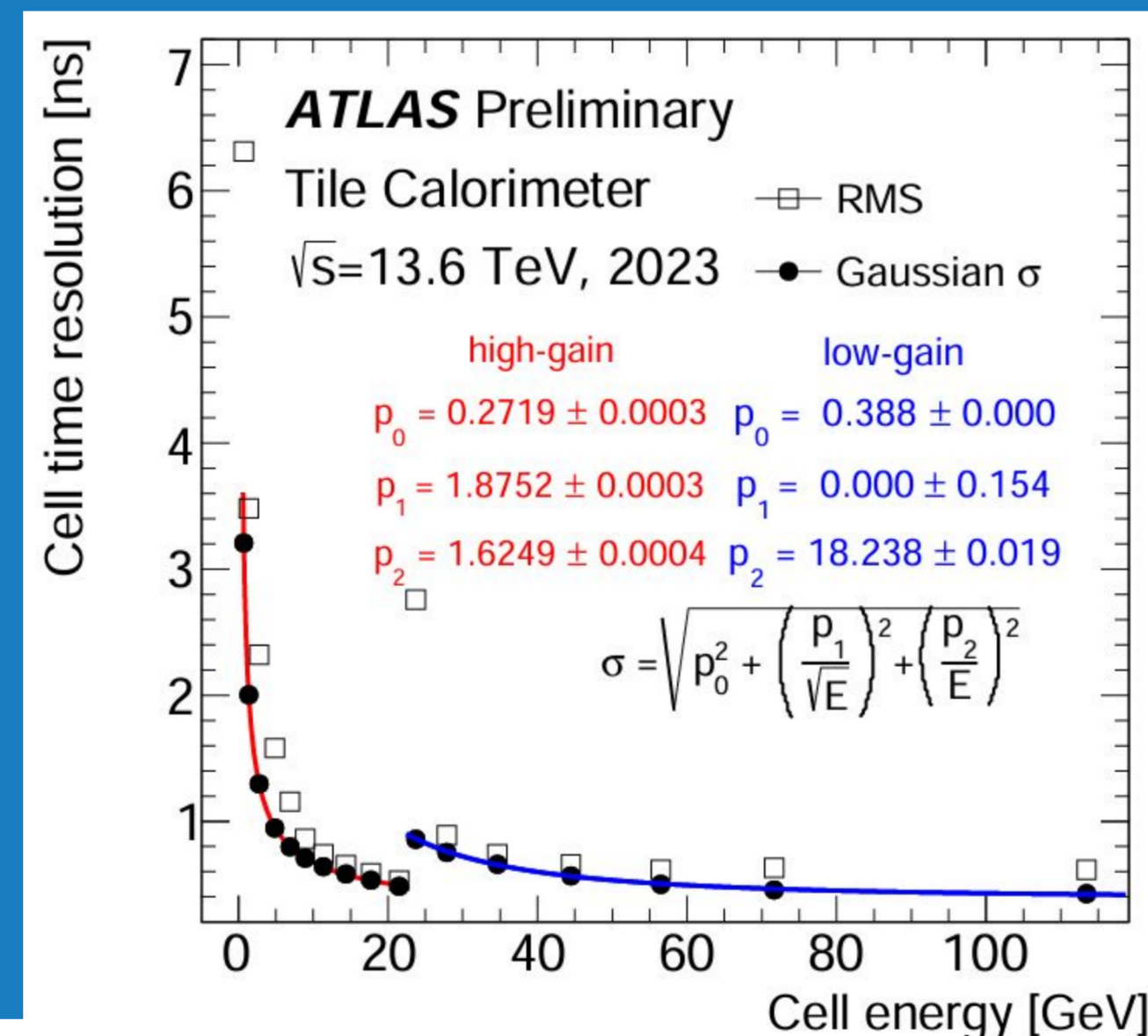

## Run 3 operations

- In  $pp$  collisions:
  - 319  $\text{fb}^{-1}$  delivered by LHC ⇒ 301  $\text{fb}^{-1}$  recorded by ATLAS
  - Tile Calorimeter efficiency on good-for-physics data above 99.5% (luminosity-weighted average)

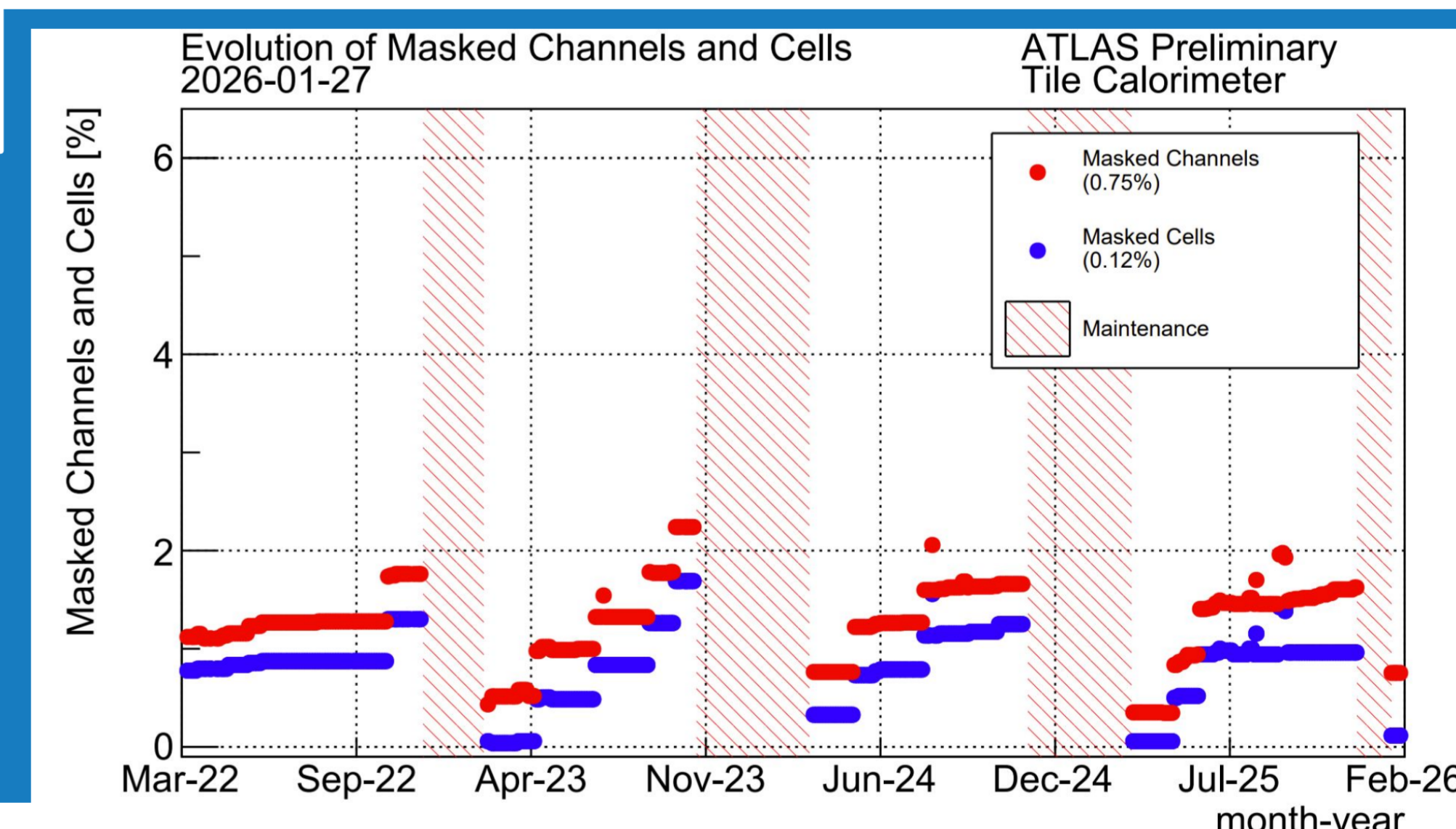

## Isolated charged hadrons

- From  $pp$  data with  $\mu \sim 0.05$
- Figure of merit: average ratio between
  - E total energy of the calorimetric clusters
  - $p$  from the projected track (from the Inner Tracker)
- Also
  - Small contribution by electromagnetic calorimeter ⇒ excluding primary  $e^\pm$  and  $\gamma$
  - Here only tracks fully contained in LB partitions (results in EB region is similar)
- Ratio generally  $< 1$  ← Tile Calorimeter is not compensated

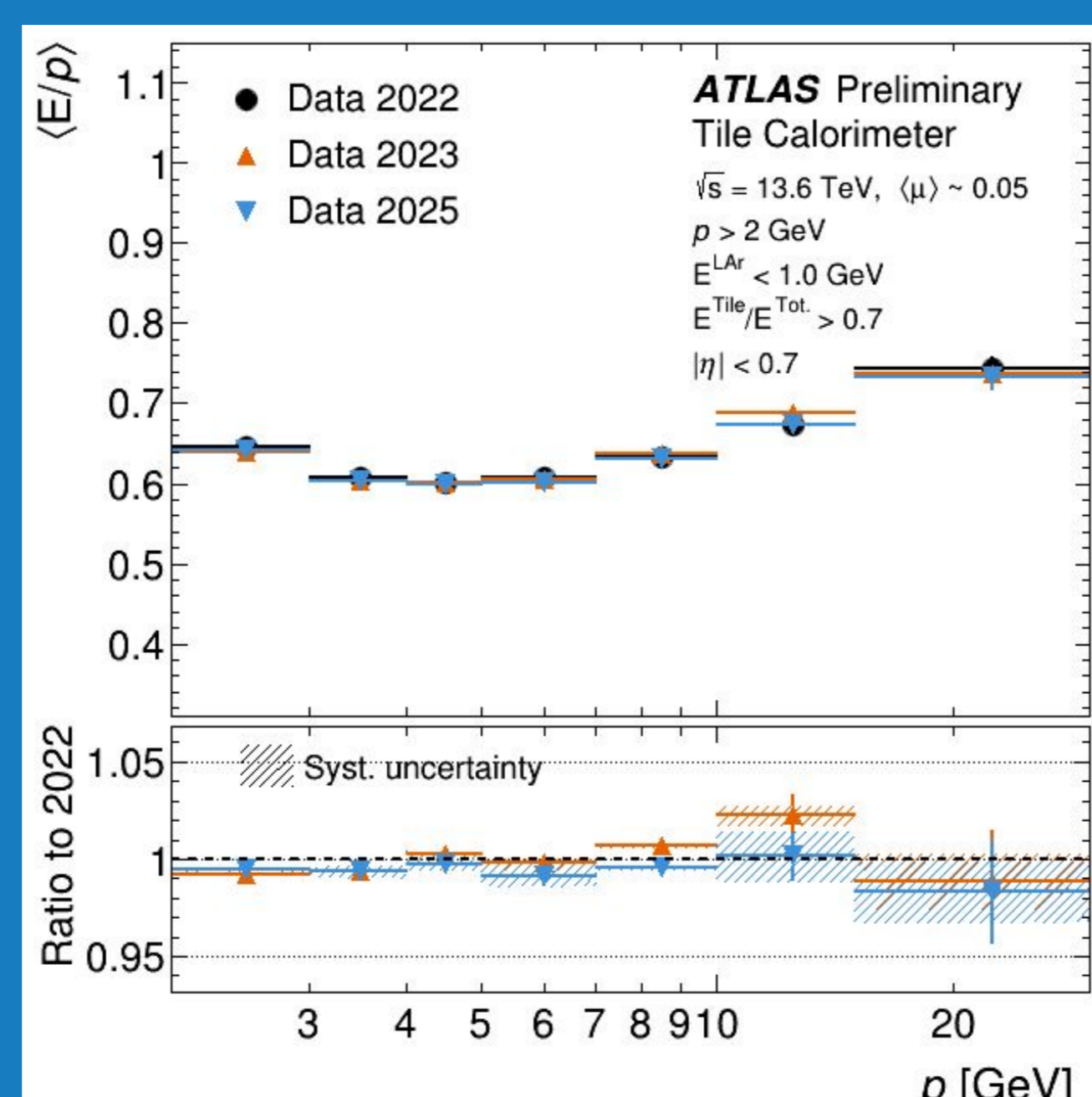

## 2026 maintenance

- Intervention on Tile Calorimeter modules between January 6<sup>th</sup> and 16<sup>th</sup>
- Successful maintenance on 20 modules
- ⇒ All is ready for the 2026 run!



All Tile Calorimeter public plots from collision data are available at <https://twiki.cern.ch/twiki/bin/view/AtlasPublic/TileCaloPublicResults>  
Further information on Tile Calorimeter is available in ATLAS Collaboration, "Operation and performance of the ATLAS tile calorimeter in LHC Run 2" *Eur. Phys. J. C* **84**, 1313 (2024)