



מכון  
ויצמן  
למדע



WEIZMANN  
INSTITUTE  
OF SCIENCE

# Toward a Beamline-Ready Optical TPC for Neutron-Induced Reactions at SARAF-II

R. Felkai, M. Borysova, L. Moleri, J. Pienaar,  
D. Vartsky, A. Breskin, I. Mor, L. Weissman and S. Bressler

5th February  
TIPP 2026, TIFR

# Motivation for an OTPC at SARAF-II

- Soreq Applied Research Accelerator Facility (SARAF) will upgrade its neutron beamline: higher beam energy ( $\sim 30$  MeV), higher current (5 mA)
- Pulsed fast neutrons with a broad energy spectrum  $\rightarrow$  Time-of-Flight (ToF) energy tagging
- Relevant to studying neutron-induced reactions in the fields of astrophysics, civil nuclear engineering and homeland security

Needs a versatile detector

SARAF-II layout

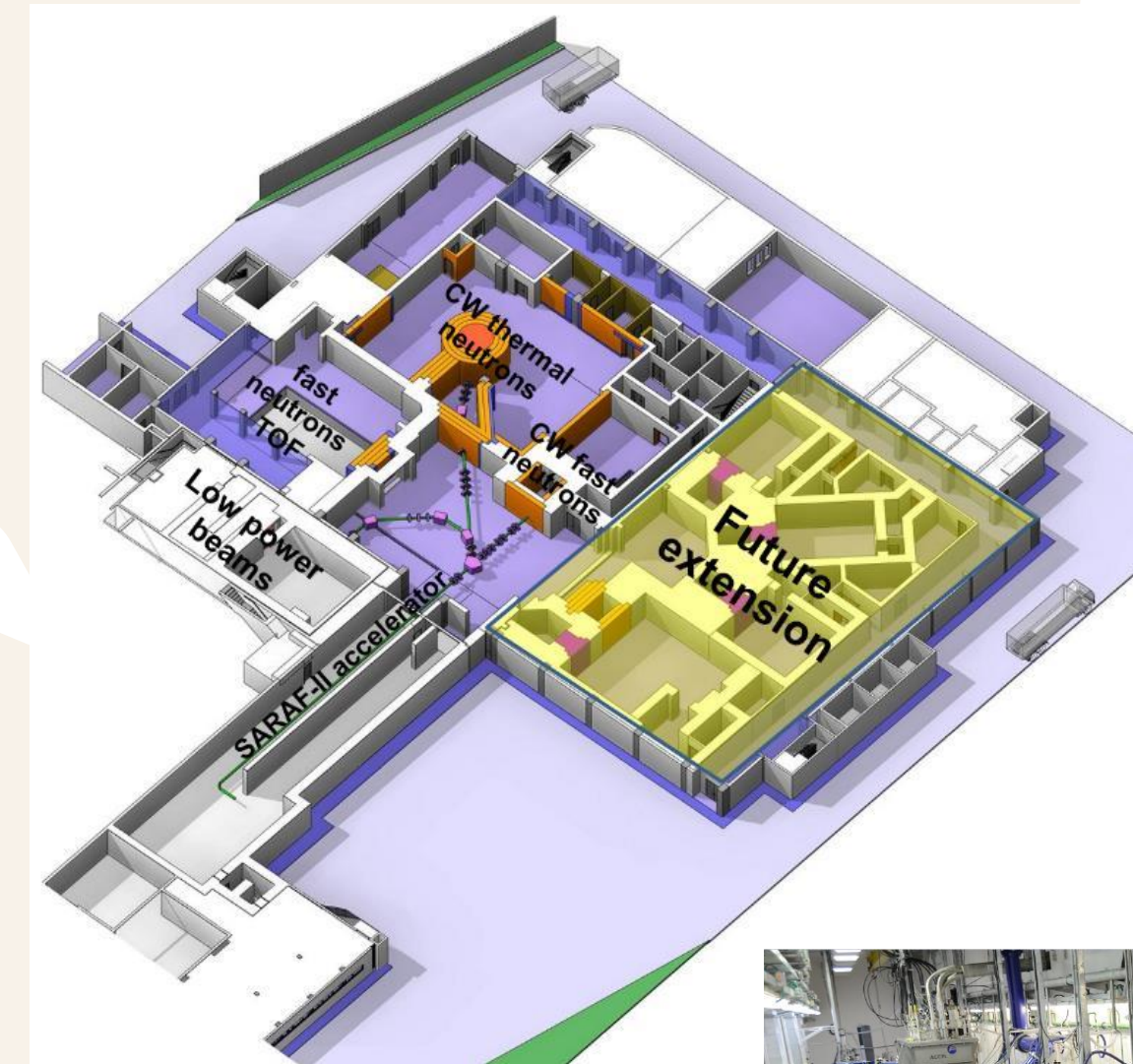

# Motivation for an OTPC at SARAF-II

- Soreq Applied Research Accelerator Facility (SARAF) will upgrade its neutron beamline: higher beam energy ( $\sim 30$  MeV), higher current (5 mA)
- Pulsed fast neutrons with a broad energy spectrum  $\rightarrow$  Time-of-Flight (ToF) energy tagging
- Relevant to studying neutron-induced reactions in the fields of astrophysics, civil nuclear engineering and homeland security

Needs a versatile detector



- Optical Time Projection Chambers (OTPCs) are gas detectors that provide nearly  $4\pi$  acceptance and event-by-event tracking
- Primary scintillation (S1) and electroluminescence (S2) enable 3D reconstruction of the final state
- PID from range and  $dE/dx$
- Single versatile detector: tunable gas/pressure to optimize the performance to specific reactions
- $CF_4$  is a molecular gas emitting light in the near-UV and in the visible: compatible with modern scientific cameras

SARAF-II layout

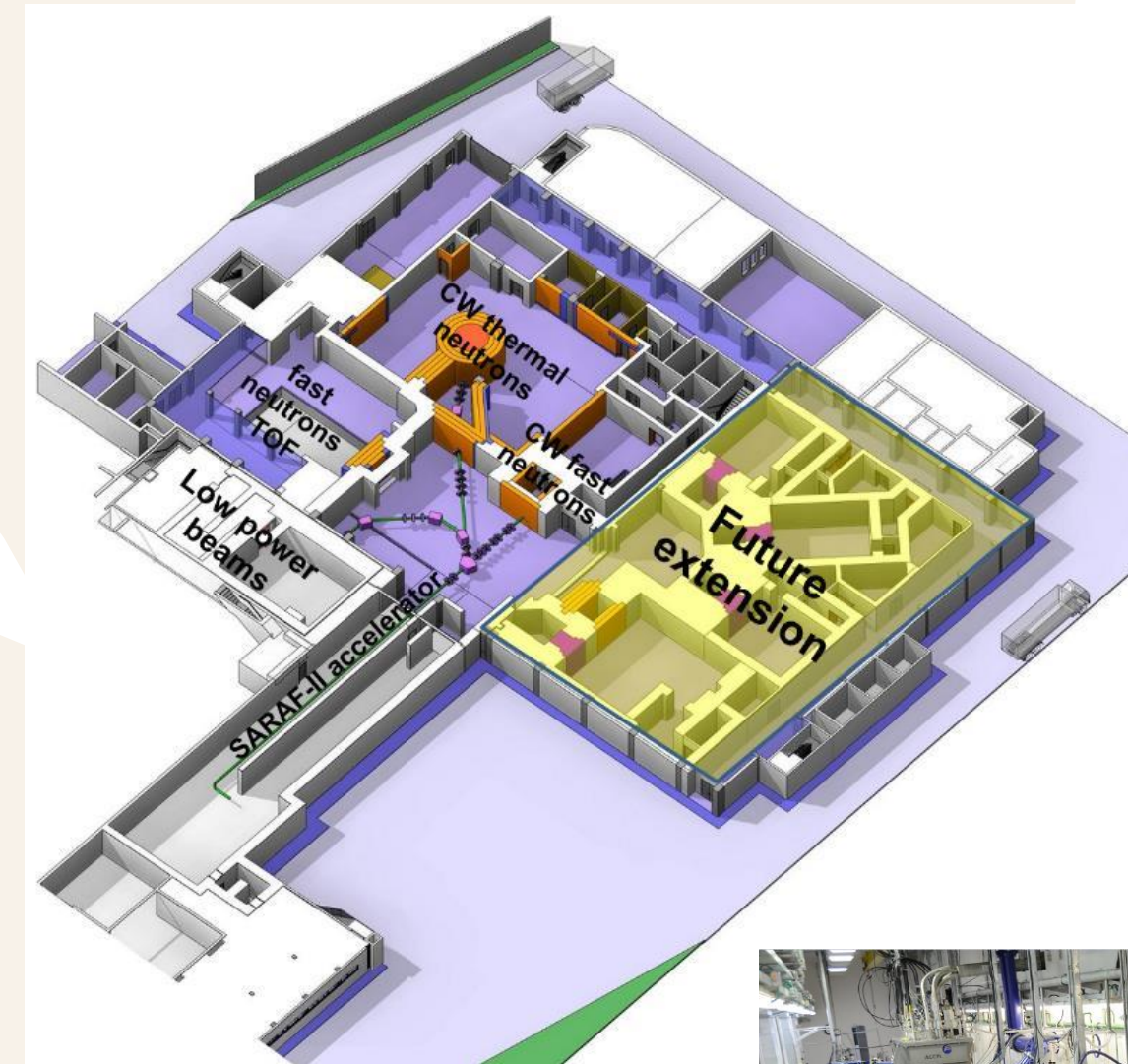

# Project roadmap

## Prototype at Weizmann

- Electron transport, charge amplification, electroluminescence and imaging
- Test-bench for novel imaging techniques

This talk

# Project roadmap

## Prototype at Weizmann

- Electron transport, charge amplification, electroluminescence and imaging
- Test-bench for novel imaging techniques

This talk

## Multi-purpose detector

- Scaled up geometry (20 cm drift length)
- Tunable pressure (10 mbar up to 1 bar)
- Modular design

In progress

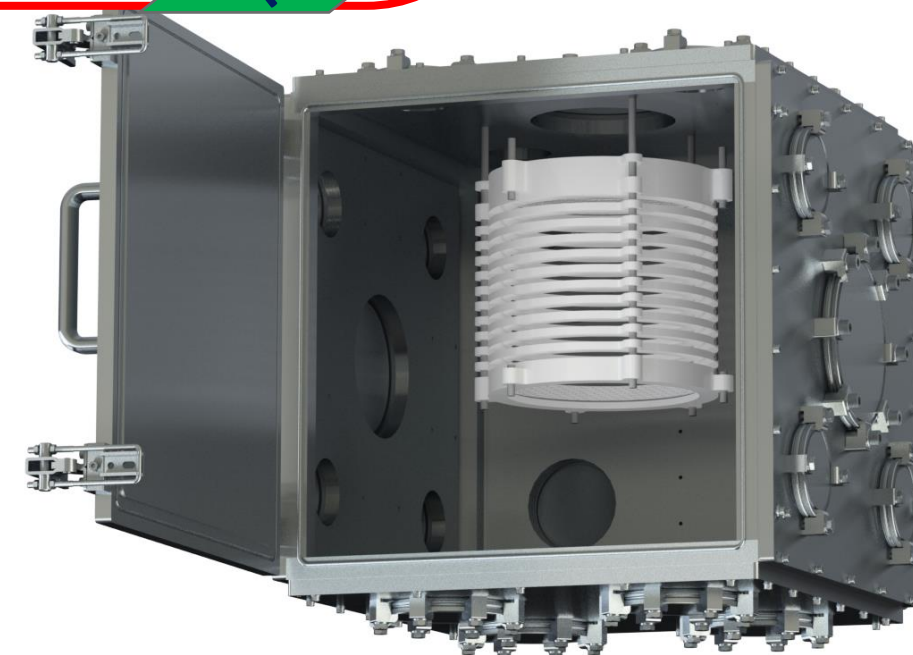
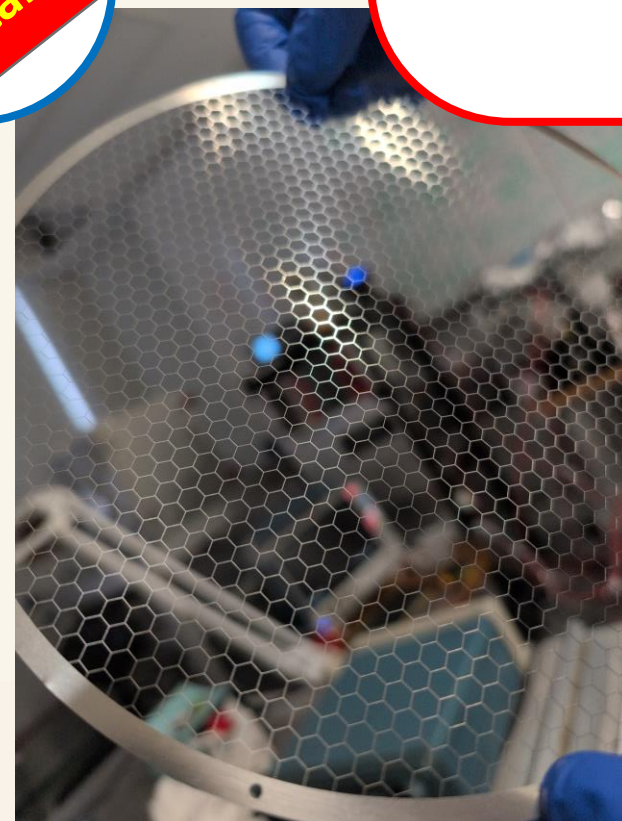

# Project roadmap

## Prototype at Weizmann

- Electron transport, charge amplification, electroluminescence and imaging
- Test-bench for novel imaging techniques

This talk

## Multi-purpose detector

- Scaled up geometry (20 cm drift length)
- Tunable pressure (10 mbar up to 1 bar)
- Modular design

In progress

## Commissioning + Physics

- Simulations:
  - Neutron background
  - Reaction products
- Early runs: Collimated nuclear reactor neutron flux on Boron-10 targets

In progress

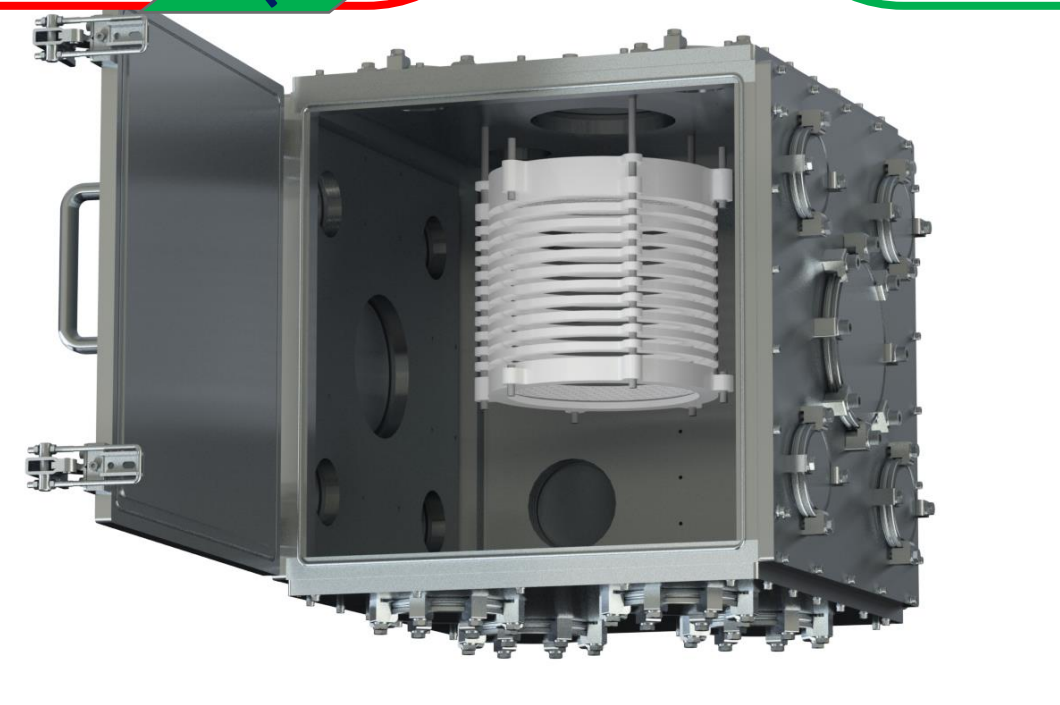
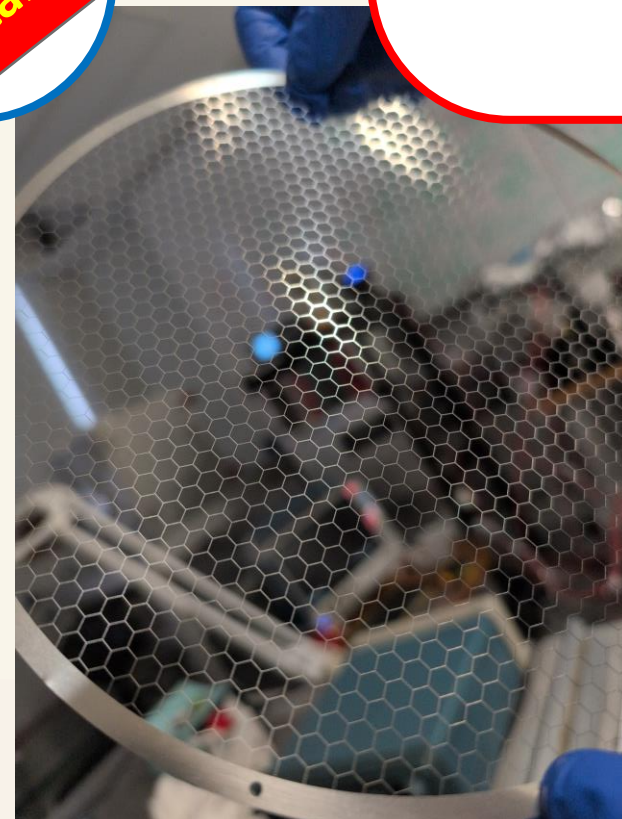
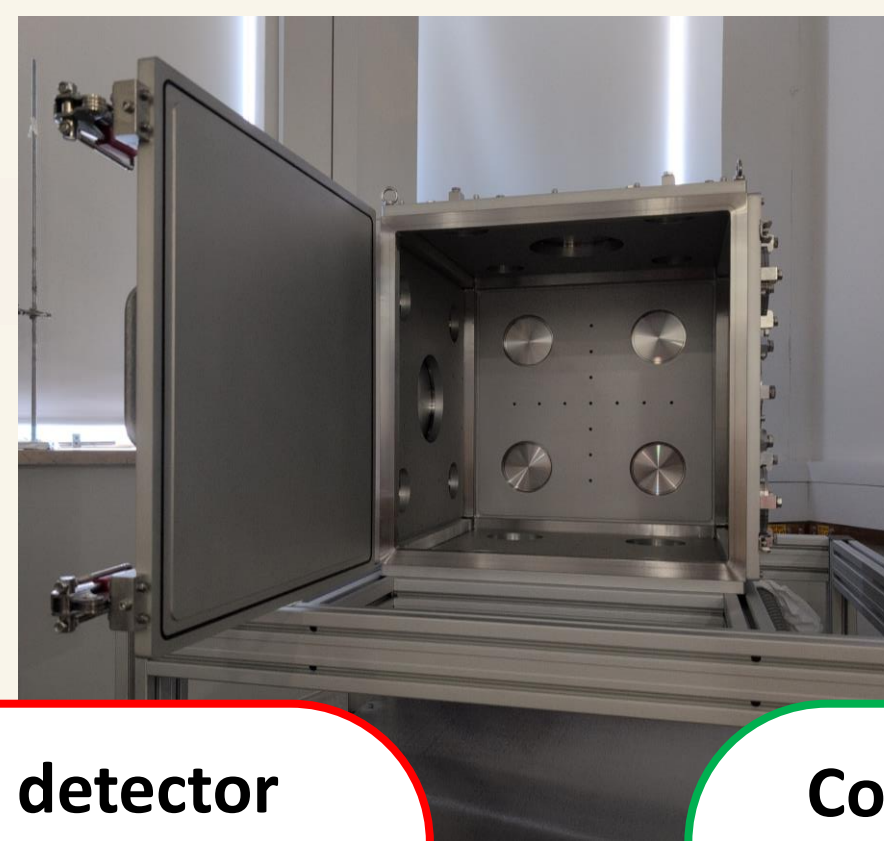

# Prototype assembled at Weizmann

- Baseline gas mixture: Ar:CF<sub>4</sub> 95:5 at 1 bar (constant flow)
- Field cage: Stack of copper-clad FR4 (~ 5 cm max drift length)
- 4 woven mesh electrodes (500 μm pitch, 50 μm ø, 81% T):
  - 1 drift cathode, 1 drift anode and 2 amplification anodes
- A broadband PMT behind the cathode (sensitive to S1)
- Orca-Quest2 camera with ultra-fast lens behind a fused silica viewport
- Low activity (30 Bq) Am-241 source placed behind the drift cathode

Setup views

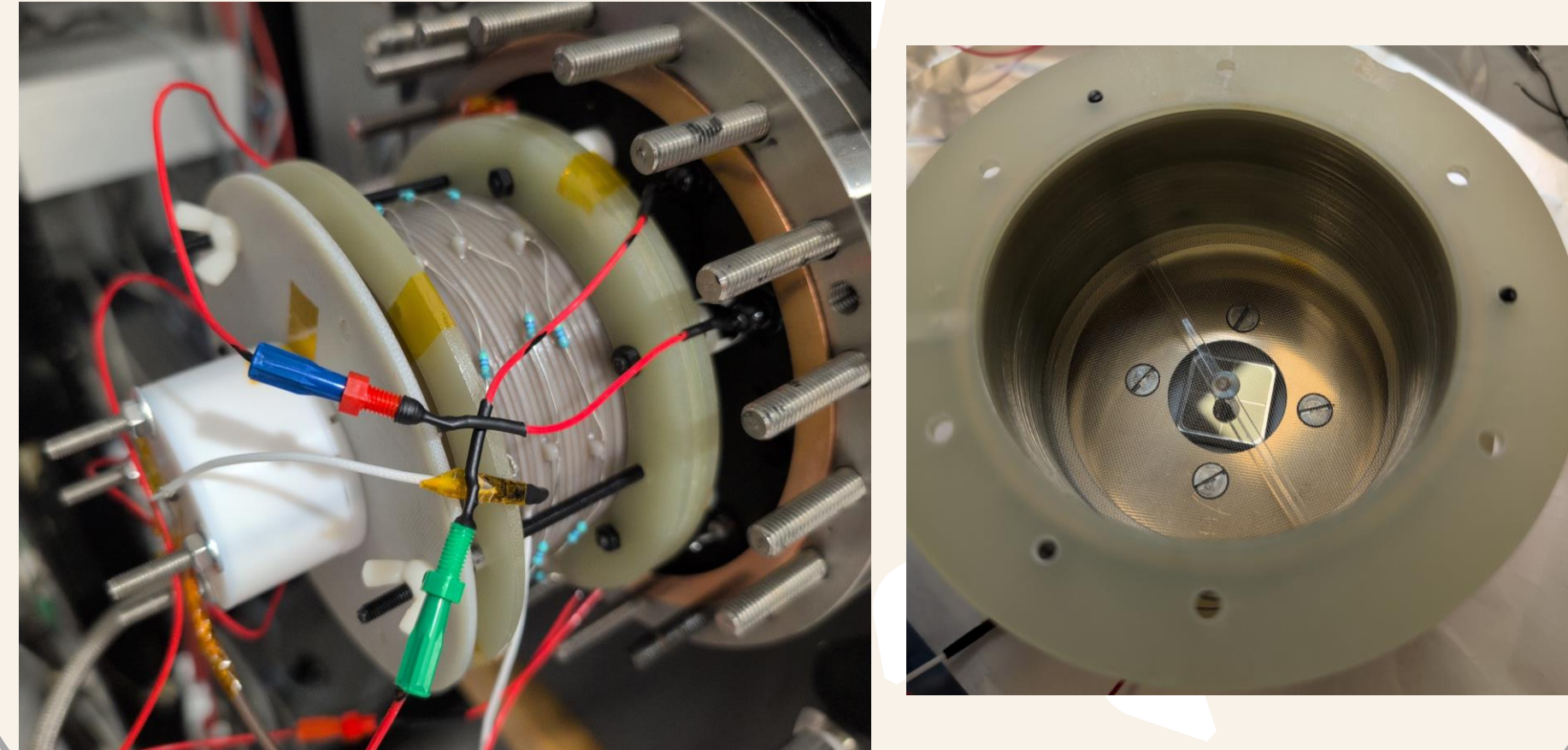

TPC configuration

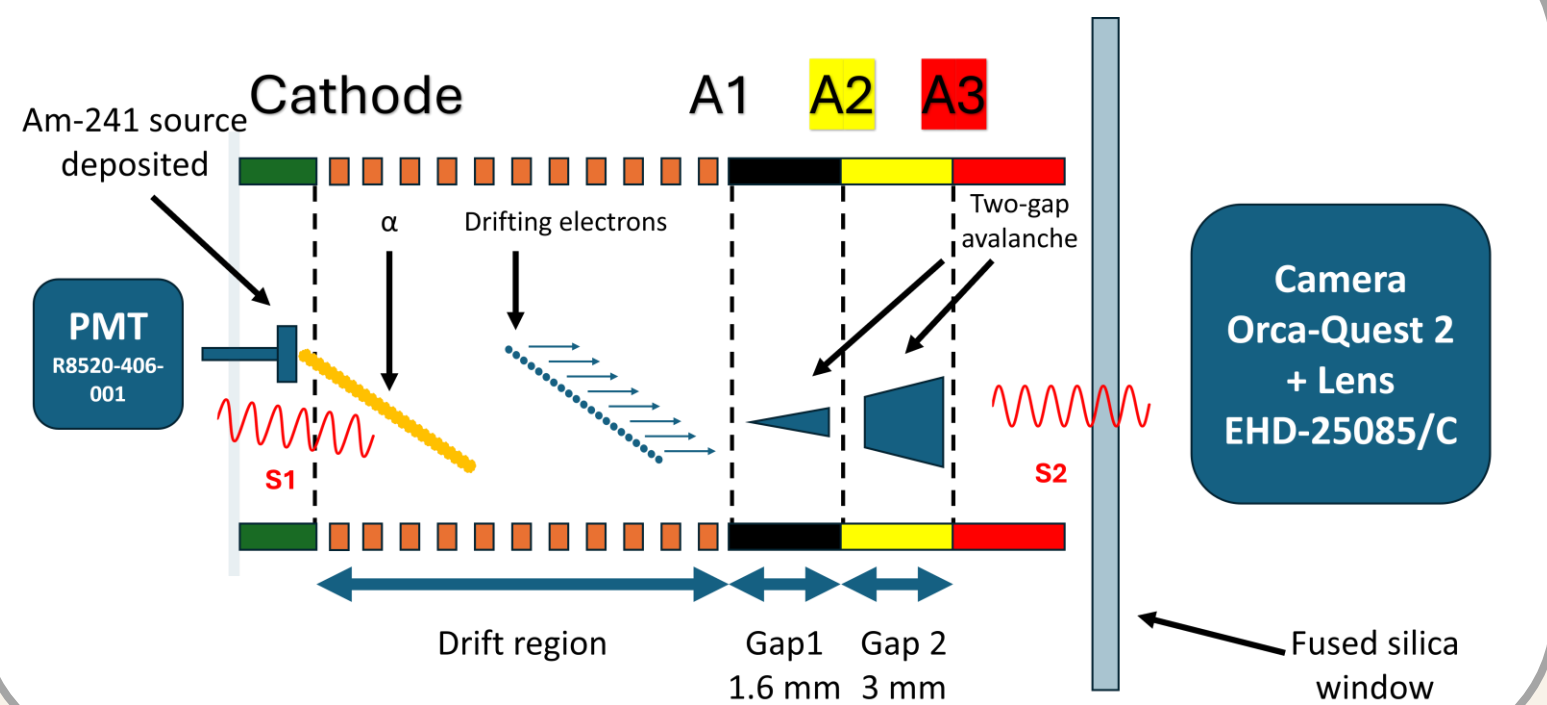

Example of a PMT signal at moderate amplification

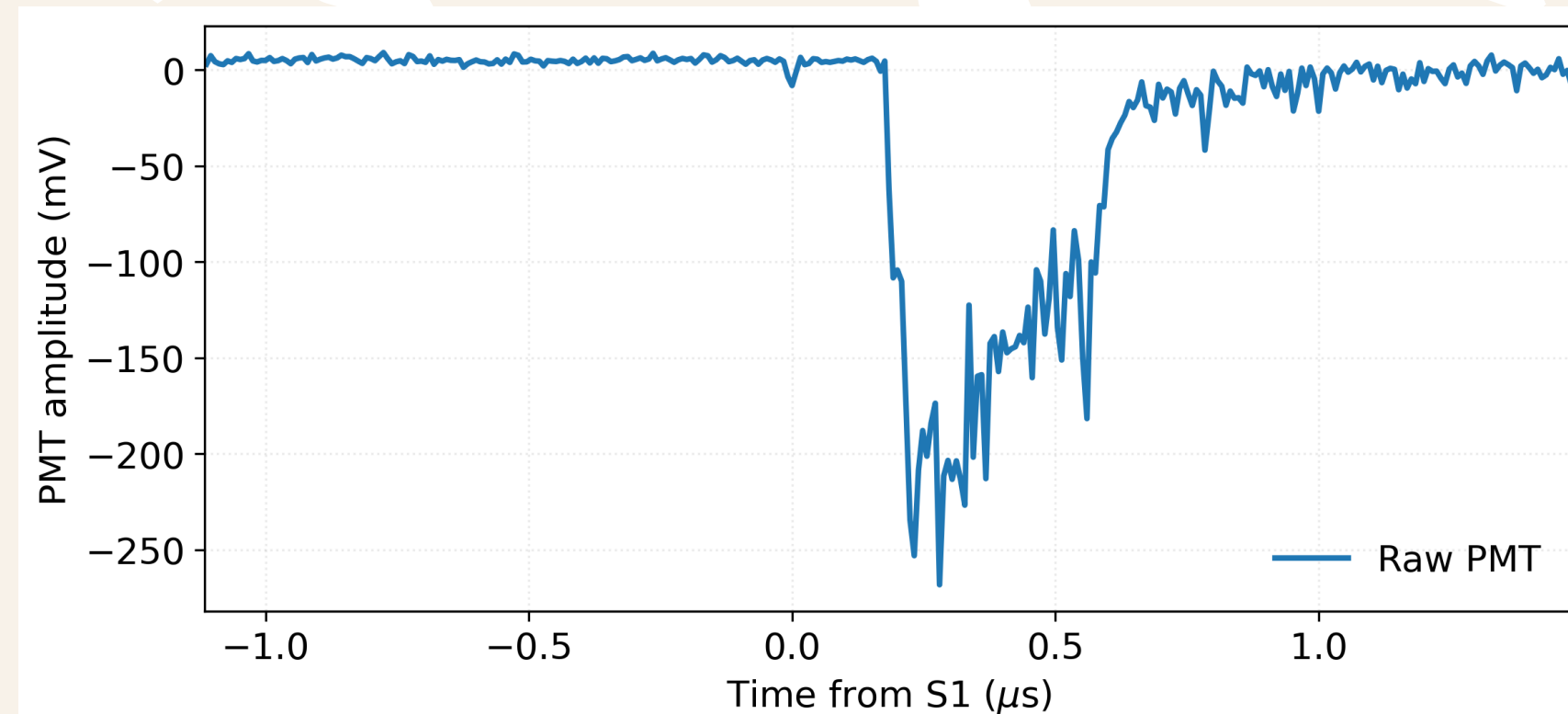

# Electron transport in the drift region

Two ways to compute the electron drift velocity:

- Drift anode charge signal rise time (drift-only)
- Extrapolation of the anti-correlation between S2 delay and S2 duration

These methods take advantage of the alphas being emitted from behind the drift cathode

## Direct measurement from preamp rise time (drift-only)

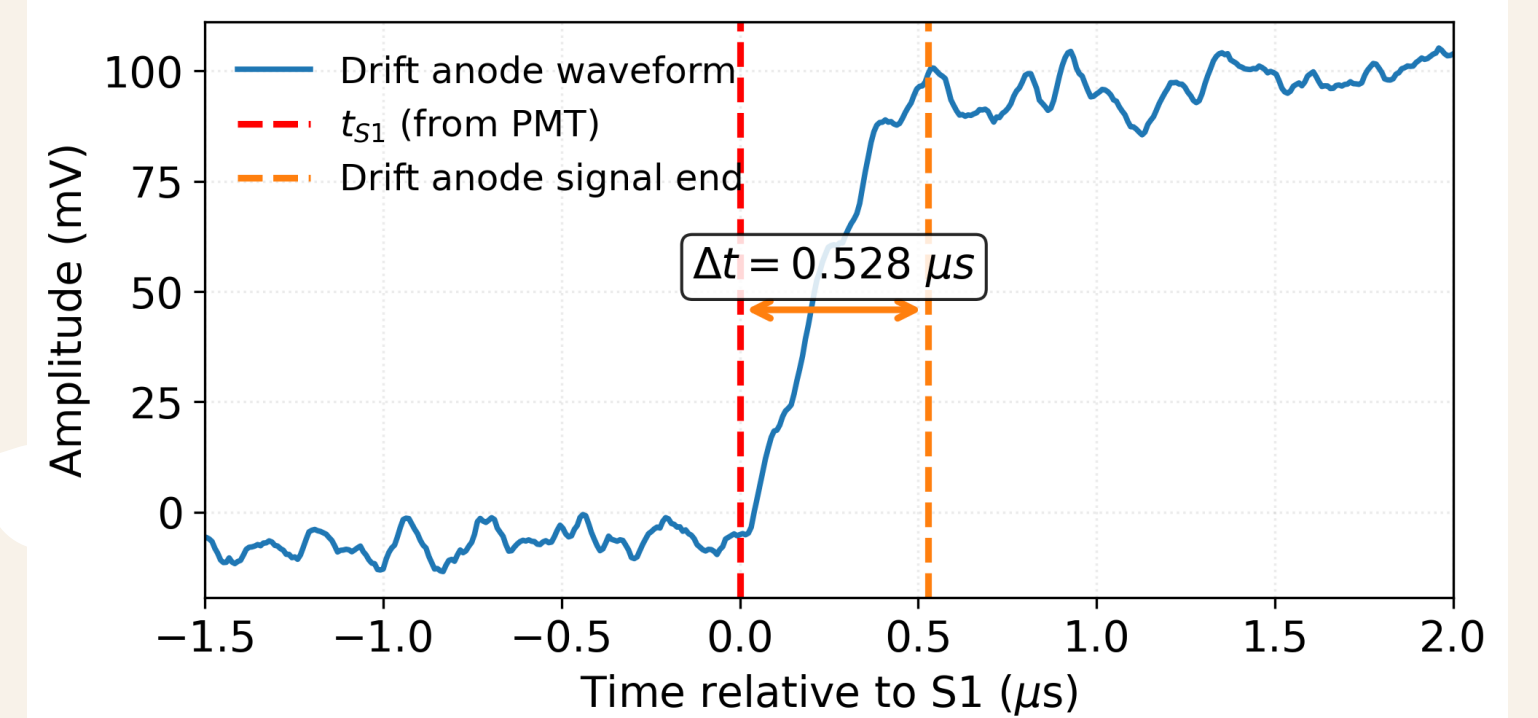

## S2 delay wrt S1 ( $\Delta t$ ) vs S2 duration (drift field of 200 V/cm)

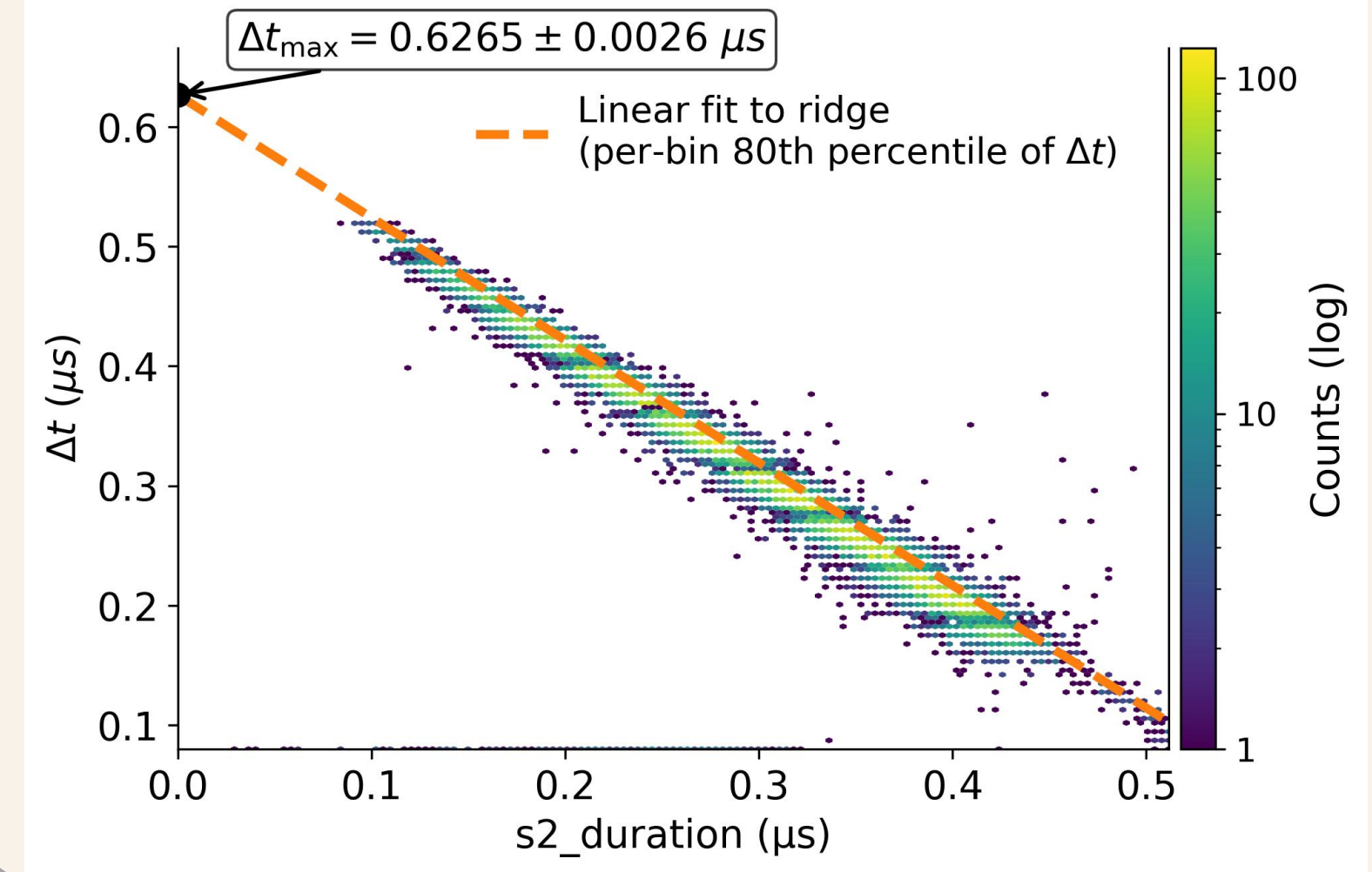

Knowing the drift velocity is required to convert drift time into distance

# Electron transport in the drift region

Two ways to compute the electron drift velocity:

- Drift anode charge signal rise time (drift-only)
- Extrapolation of the anti-correlation between S2 delay and S2 duration

These methods take advantage of the alphas being emitted from behind the drift cathode

Direct measurement from preamp rise time (drift-only)

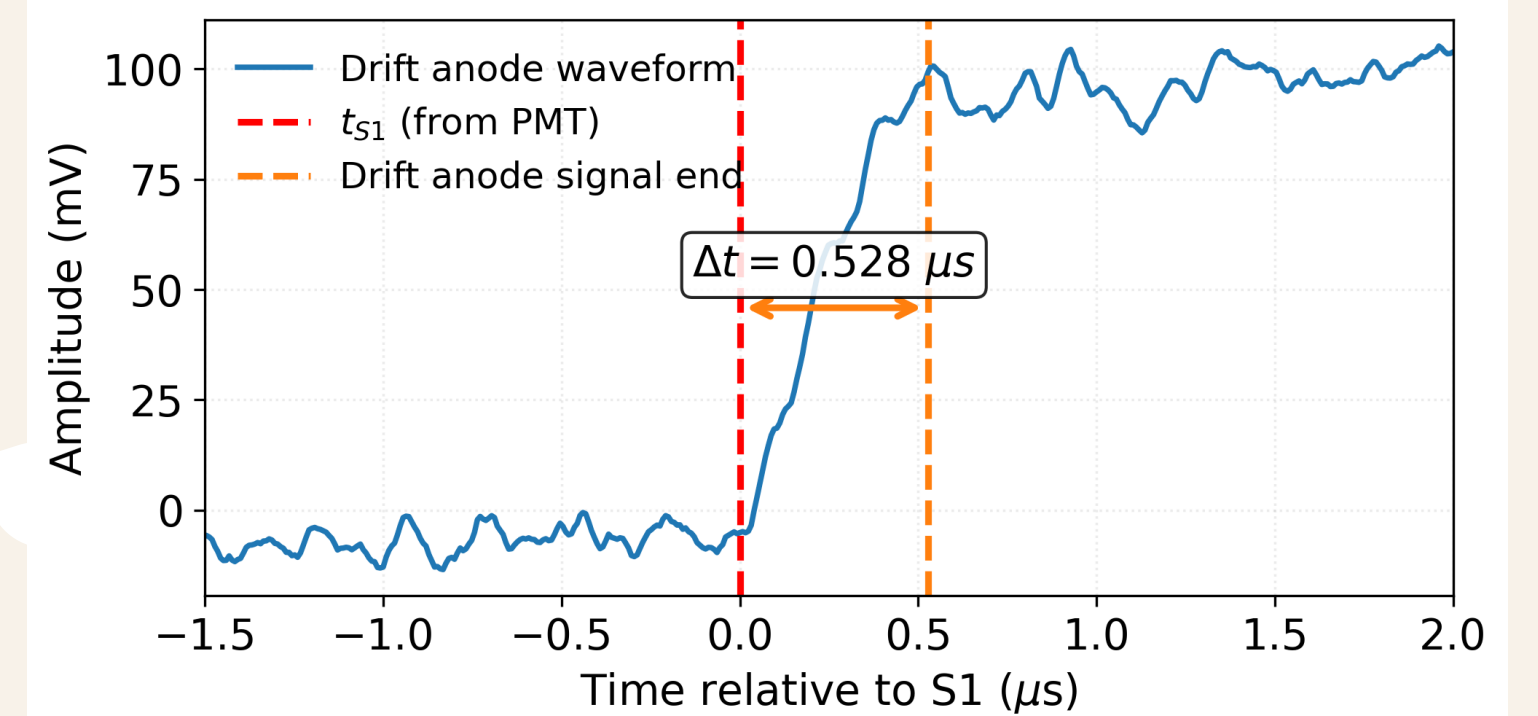

S2 delay wrt S1 ( $\Delta t$ ) vs S2 duration (drift field of 200 V/cm)

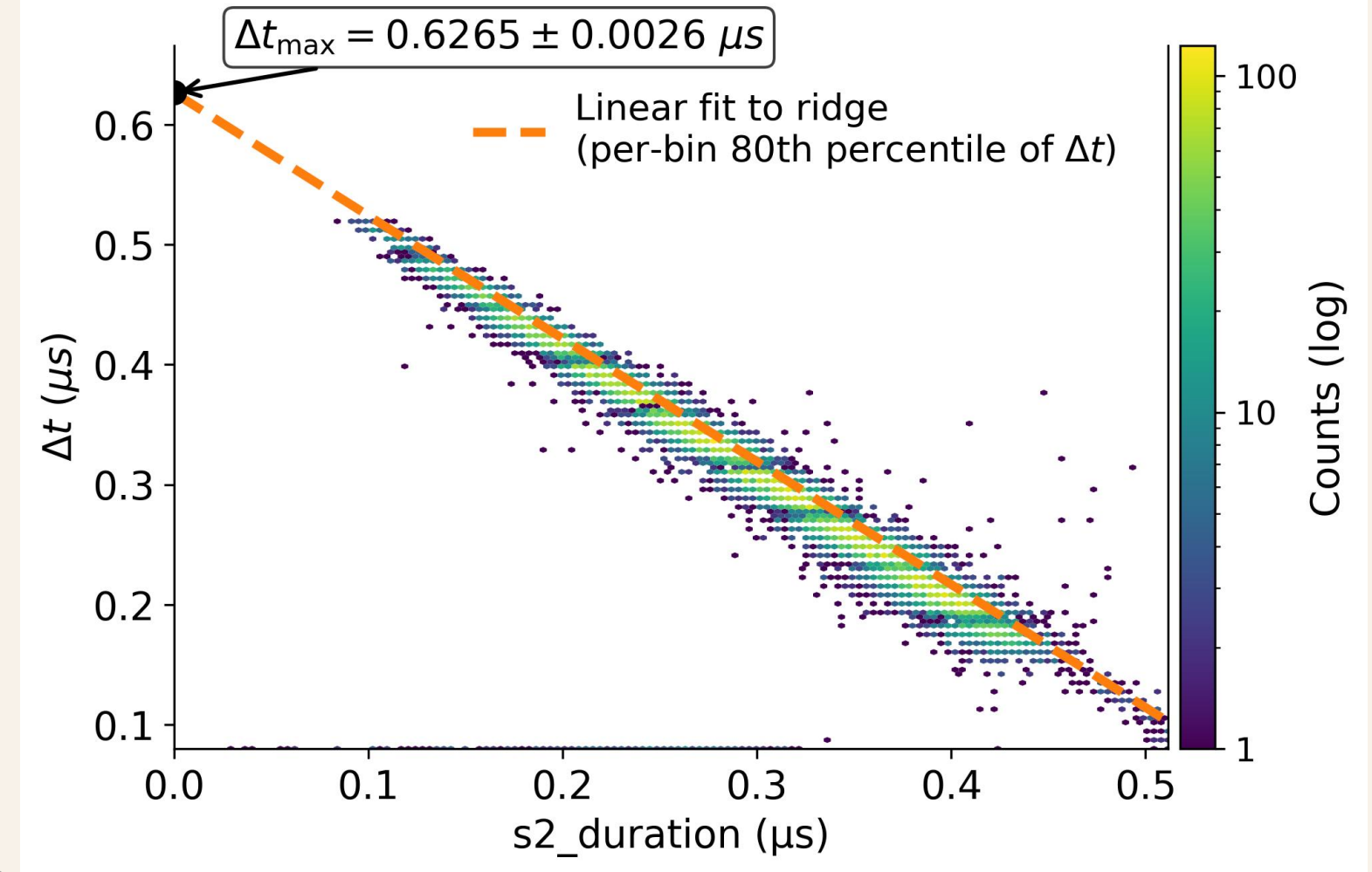

Electron drift velocity Vs Drift Field

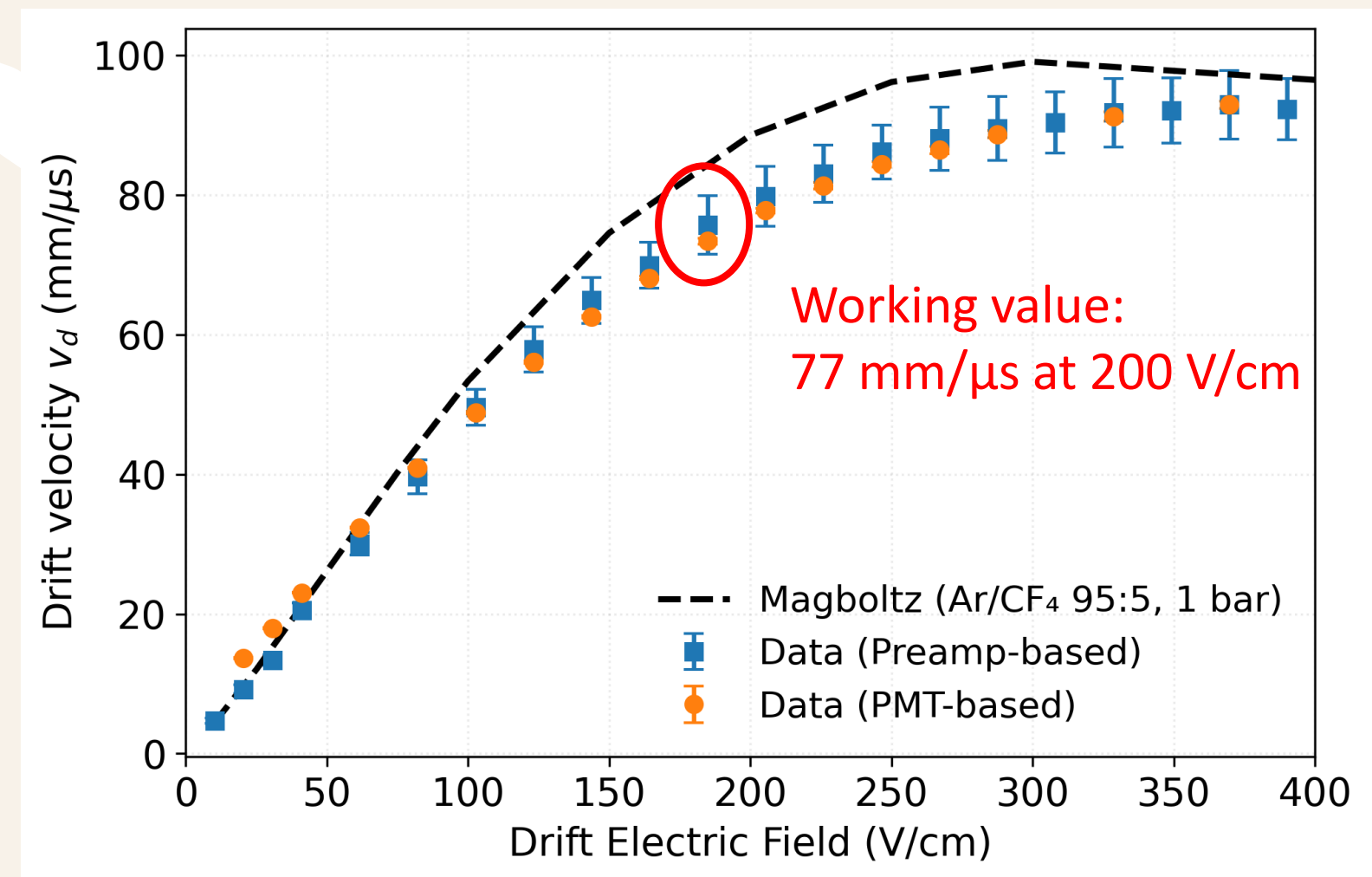

# Detector performance

## Charge gain:

- Charge sensitive preamplifier connected to the second anode
- Drift field at 200 V/cm, gap spacing 1.6 / 3 / 4.6 mm
- Collected charges normalized to that obtained in drift-only/collection

## Light yield:

- Integrate baseline-subtracted PMT waveform
- Convert to absolute yield using Ar/CF4 secondary emission spectrum [1], PMT QE and solid angle

[1] F. M. Brunbauer, Applications of gas scintillation properties in optically read out GEM-based detectors, PhD. Thesis, 2018

### Gain Vs Amplification Field

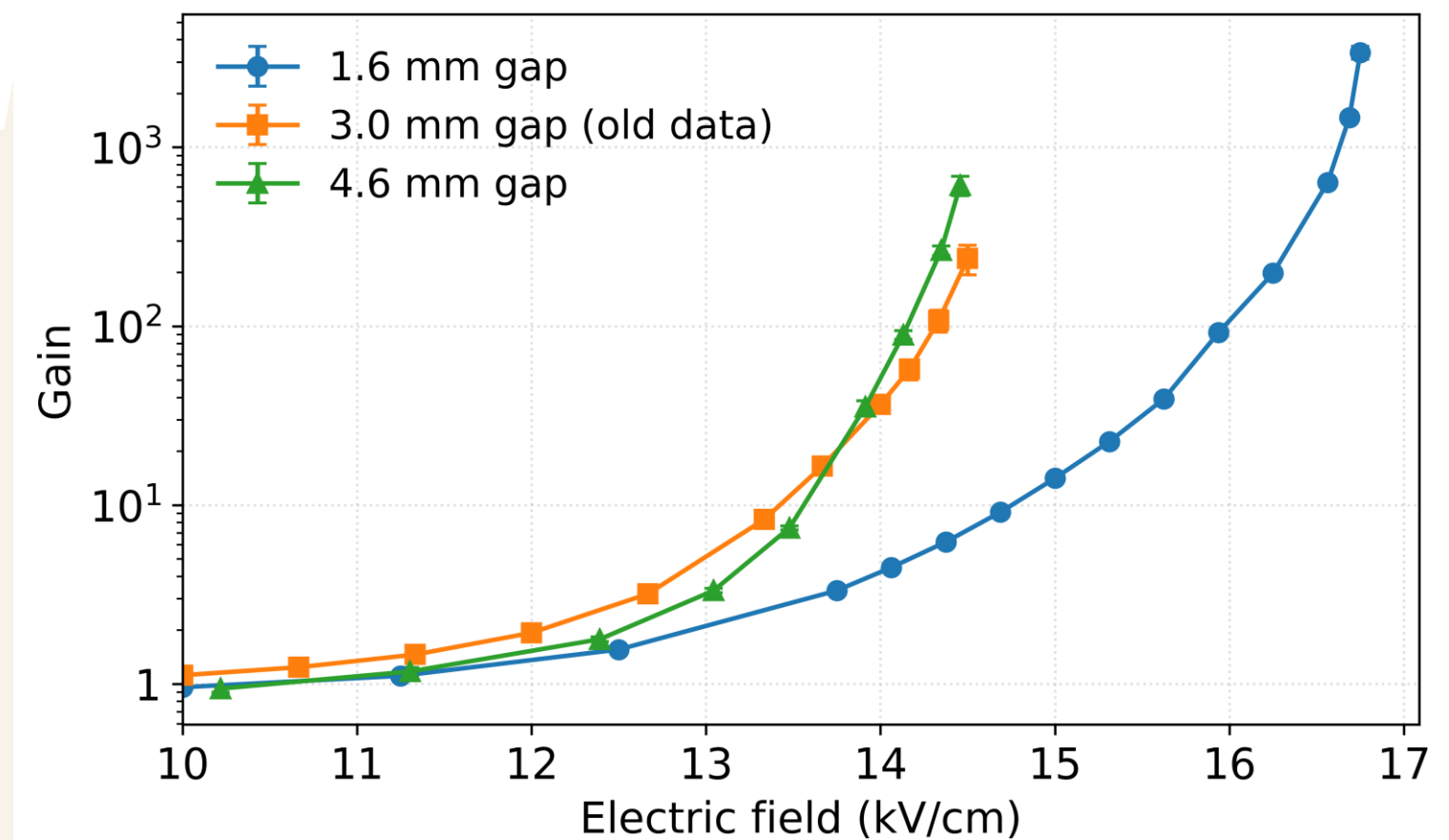

### Light Yield Vs Gain

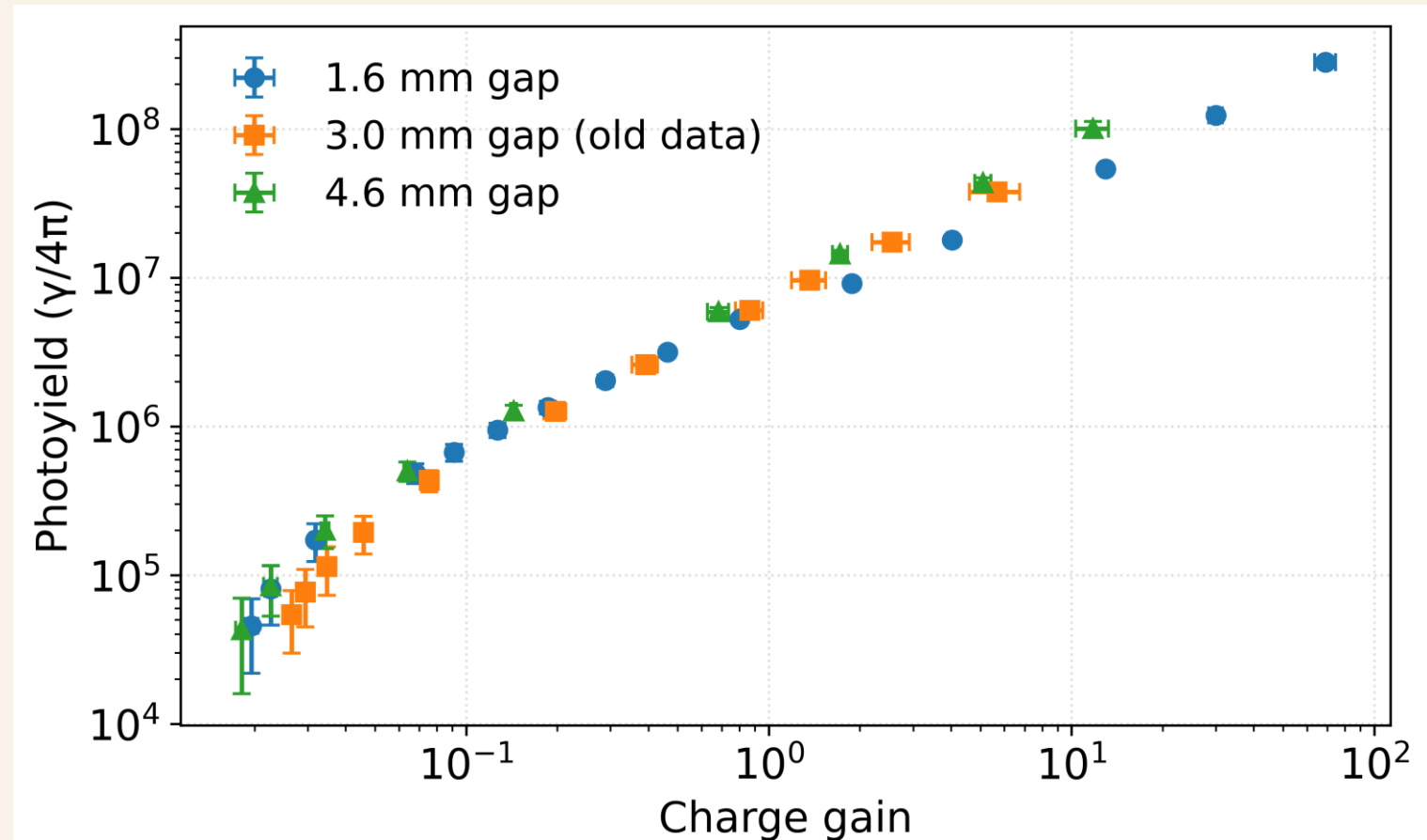



# 3D alpha tracks reconstruction

# Camera setup and synchronization with the PMT

- Global exposure timing output of the camera (TTL) connected to the oscilloscope
- Event selection: only one event per time window and within TTL
- This is a workaround for the rolling shutter of the camera coupled with USB readout limitations (we are upgrading to CoaXPress)

View of the camera in front of the detector

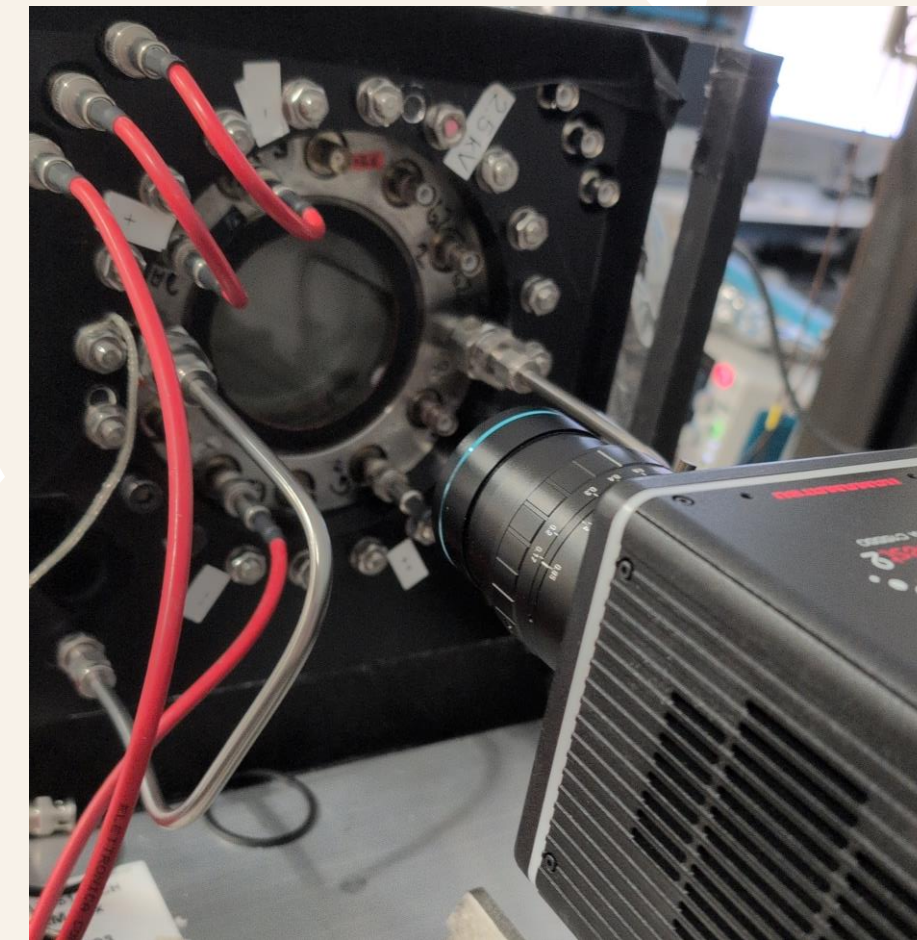
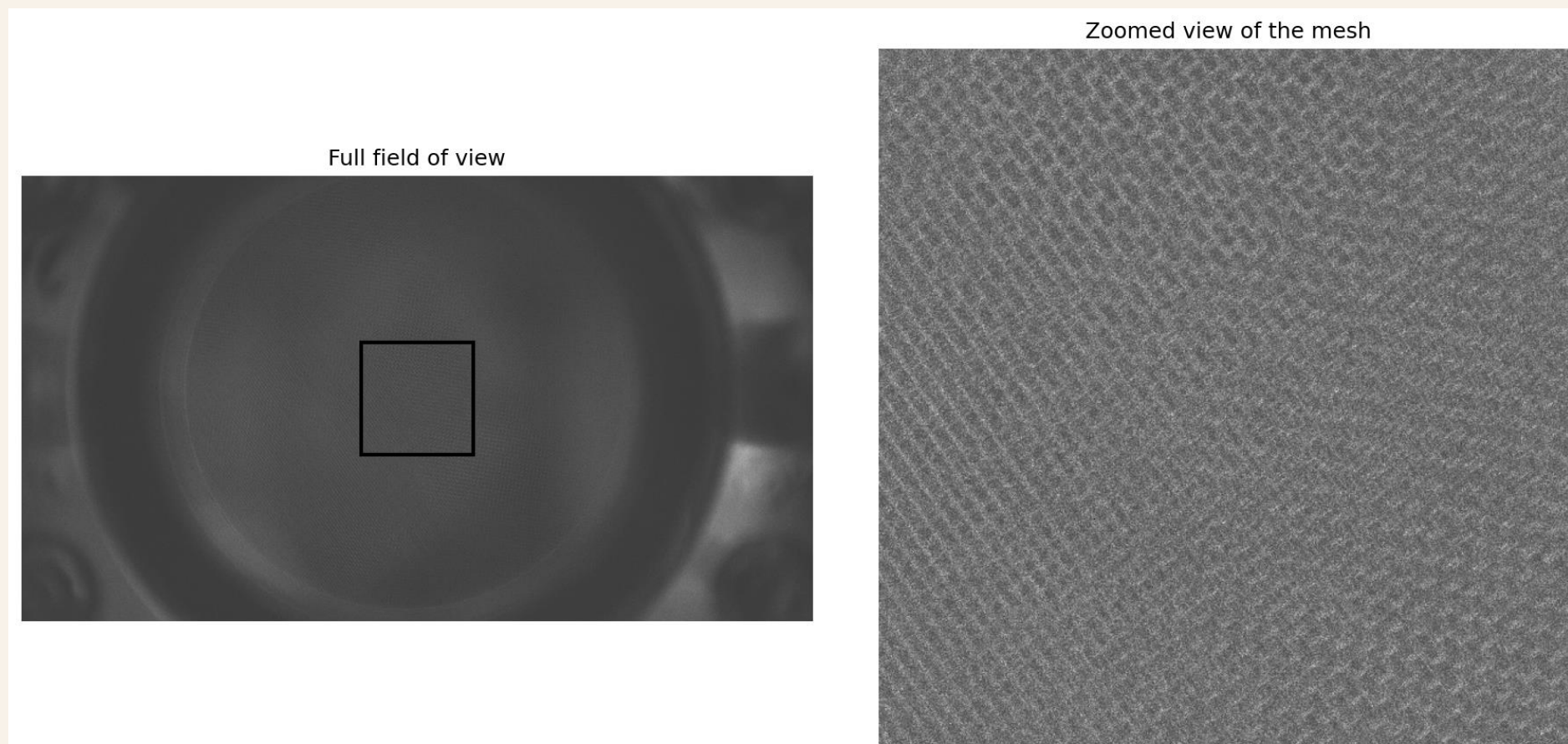
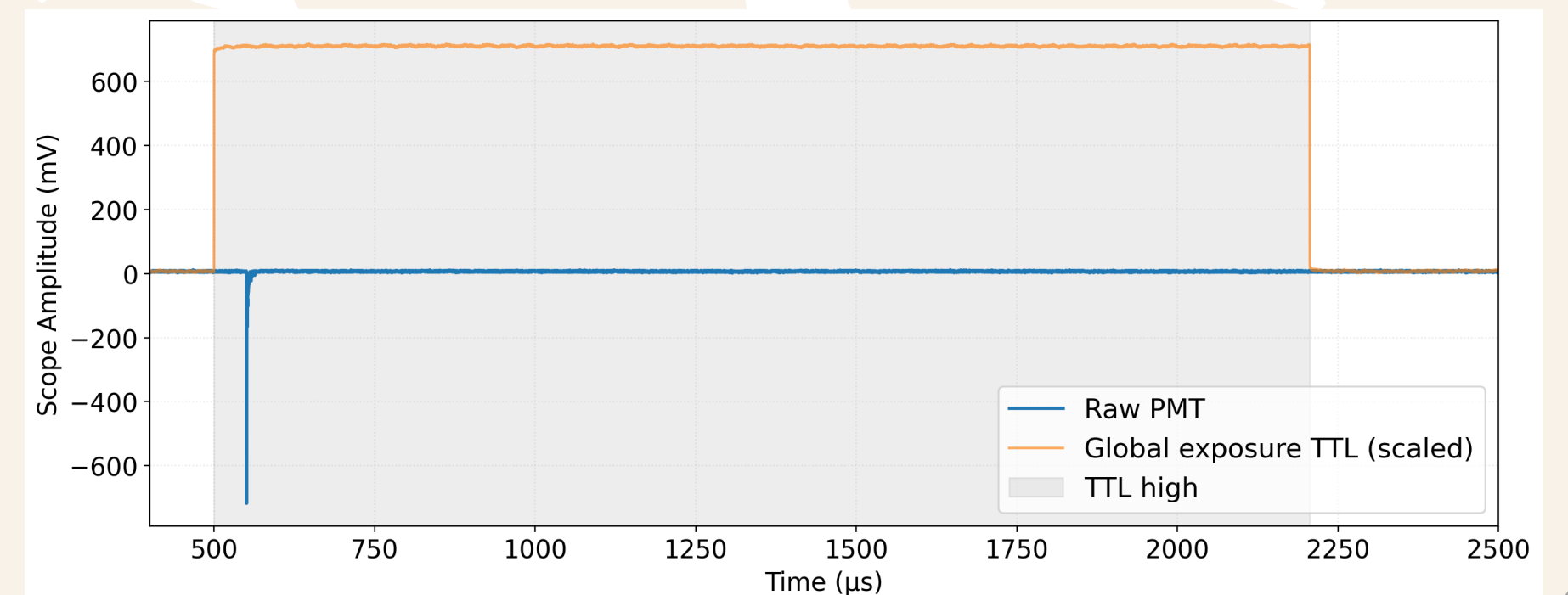

Image focused on the second and third anodes



Camera signal output in coincidence with PMT-recorded S2



# Short movie (a tribute to Satyajit Ray)

The video can be seen on the .pptx file

# 3D Track Reconstruction

## Image processing

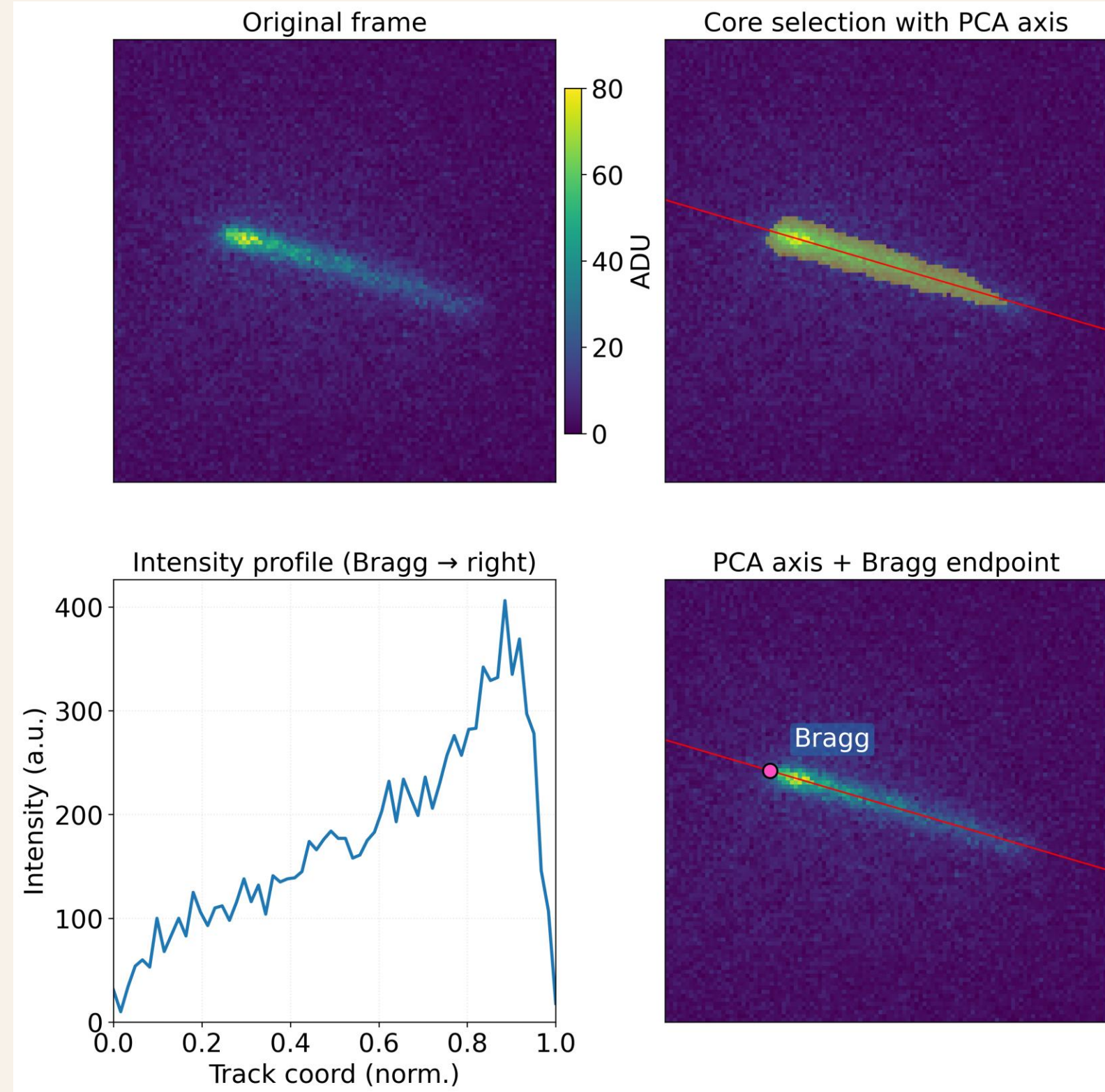

## PMT timing

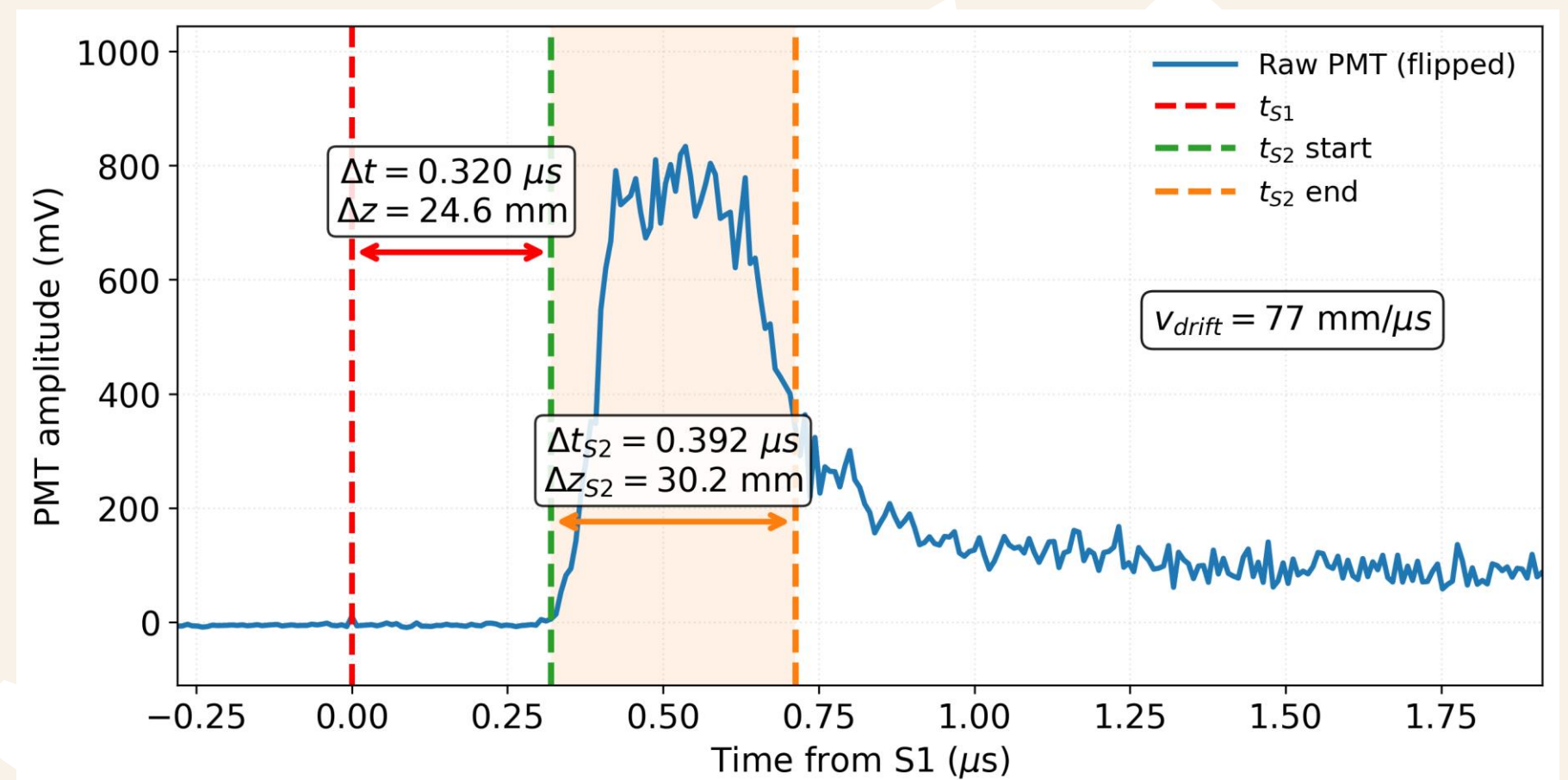

- Images are rebinned 8 x 8 to improve S/N
- Main assumption is a linear mapping between the track profile (camera) and the emission time (PMT)

# 3D Track Reconstruction

## 3D projection

The video can be seen on the .pptx file

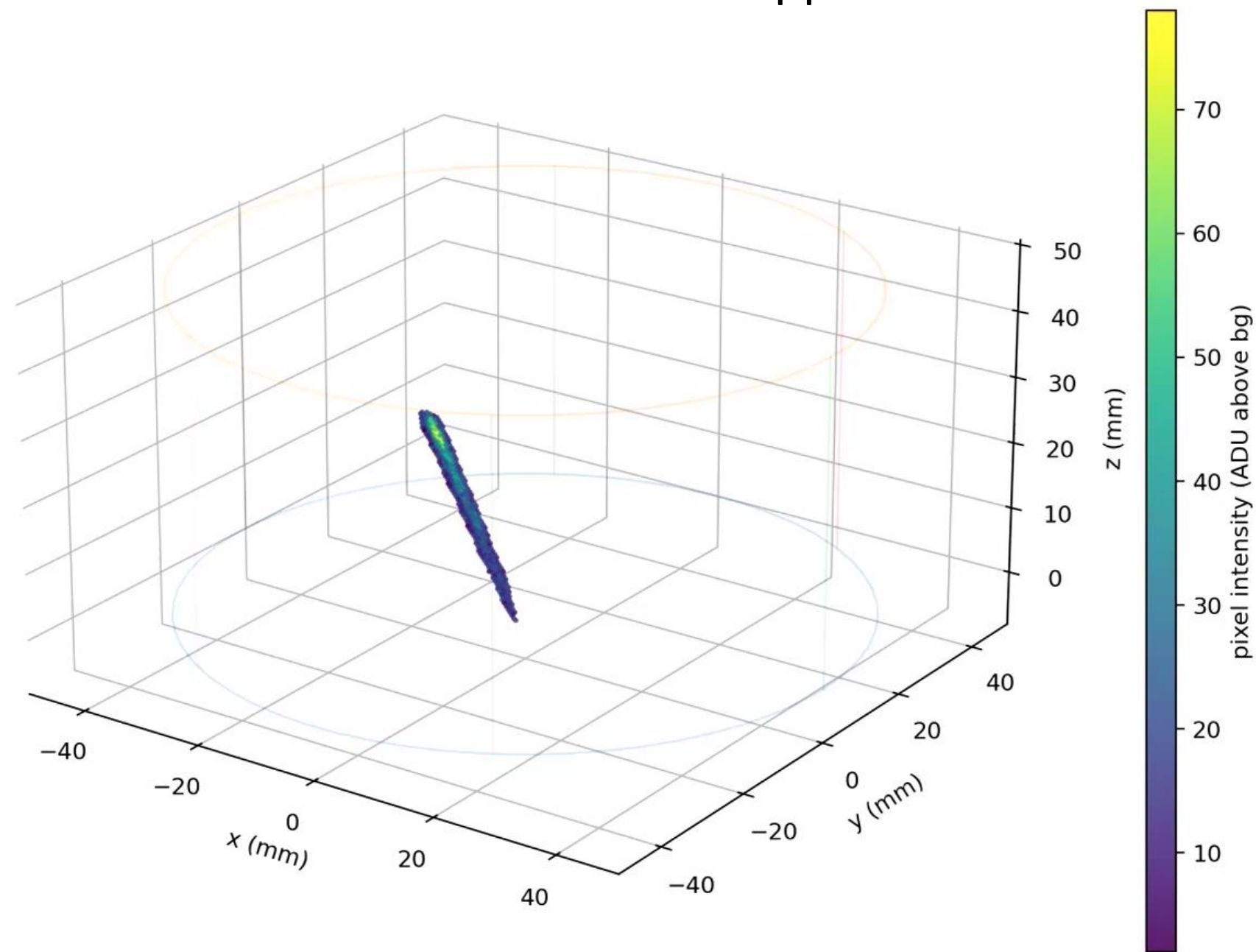

Short term limitations (can be fixed):

- Frame rate is too low (USB) which forces idle time of the camera in free running mode (event loss)

Long term limitations (intrinsic):

- 2D frame + PMT signal is challenging in multi-track events
- Frame rate limit of 120 Hz (hard limit), minimum exposure of 8 ms (lossless) likely too coarse for beamline experiments

# Conclusion and outlook: From Prototype → Beamline-ready OTPC

## 1. The OTPC prototype achieved:

- ✓ Establishing and validating methods of signal acquisition and processing
- ✓ Performance mapping in Ar:CF<sub>4</sub> 95:5 at 1 bar
- ✓ 3D track reconstruction with camera+PMT
- ✓ Understanding hardware limitations and informing the design of the next-generation detector

## 2. The prototype end-of-life scientific aim:

- ❑ Test GEM+mesh performance and hexagonal etched meshes with different stacking geometries
- ❑ Demonstrate novel ways of achieving 3D tracking
- ❑ Compare these novel ways with more classical 3D tracking done by TimePix-based camera and the camera+PMT method described previously

## 3. Beamline-ready multi-purpose detector:

- Commissioning the detector
- Performance mapping of different gas mixtures at various pressures
- Physics run with a neutron beam provided by a nuclear reactor

TimePix-based camera

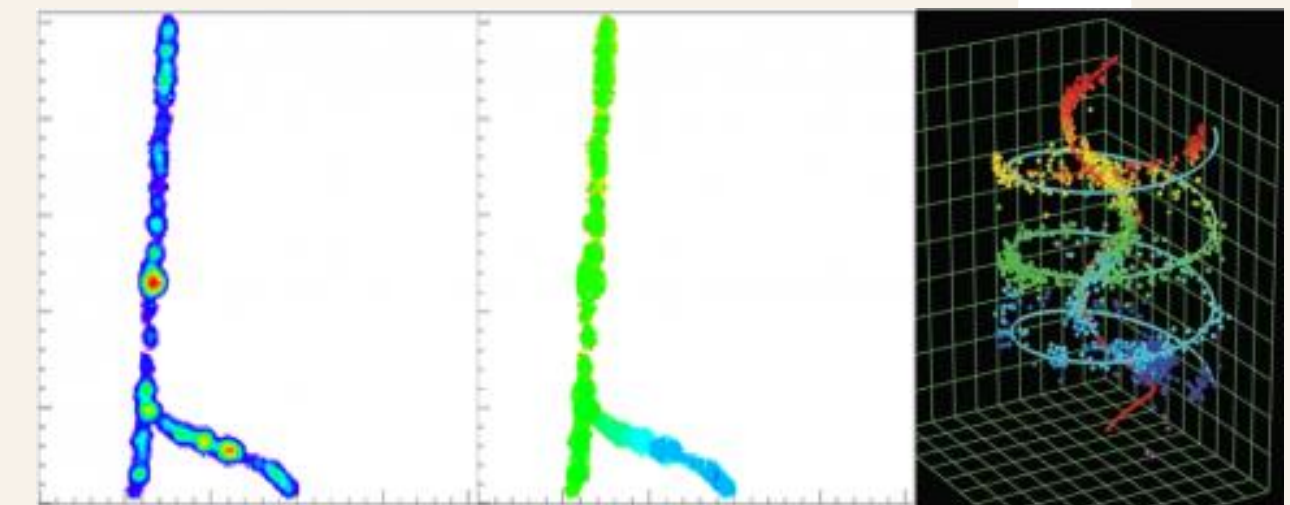

Source of the image: [Medipix collaboration website](#)



מכון  
ויצמן  
למדע

WEIZMANN  
INSTITUTE  
OF SCIENCE

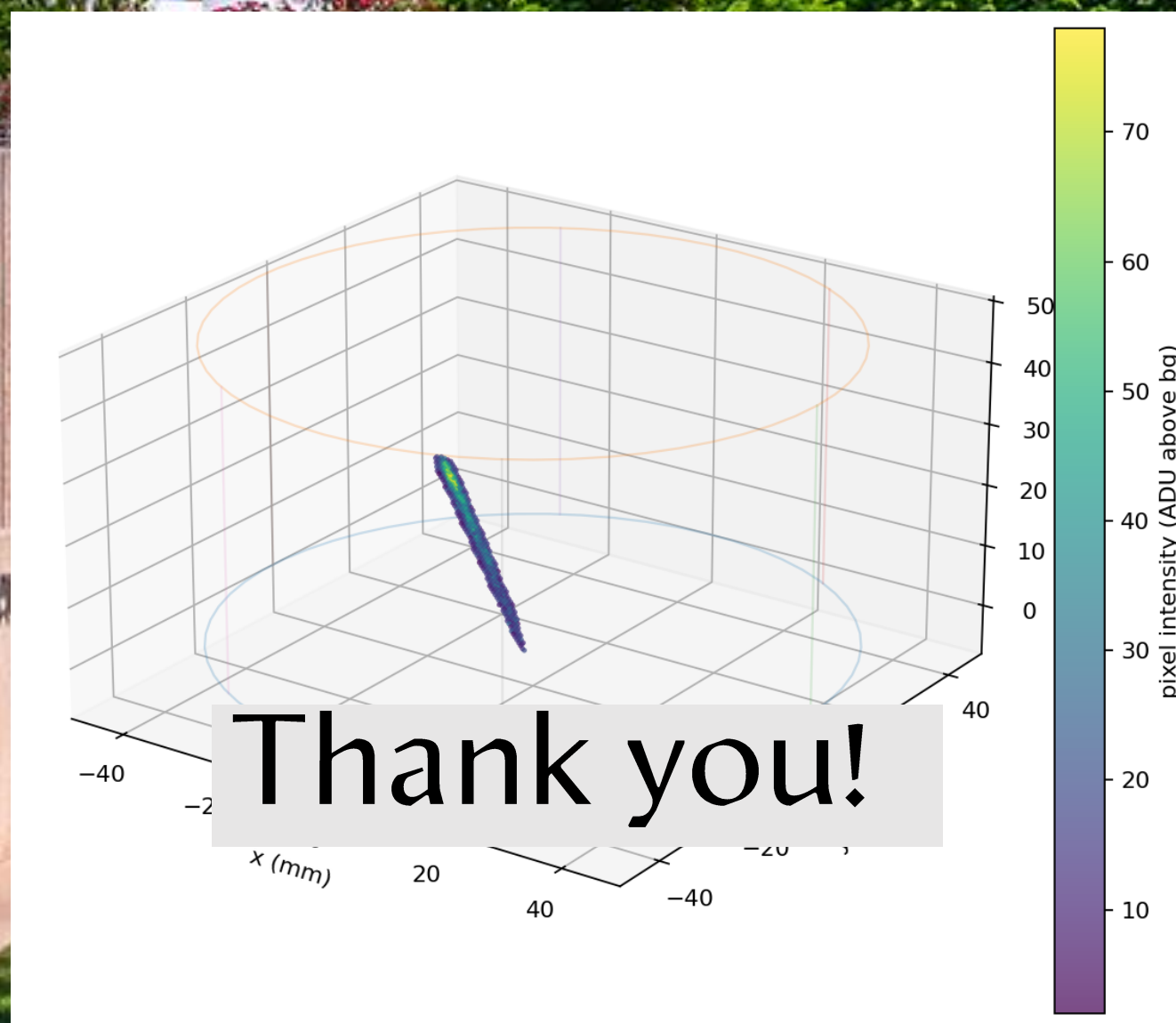

# Backup: Detector Views

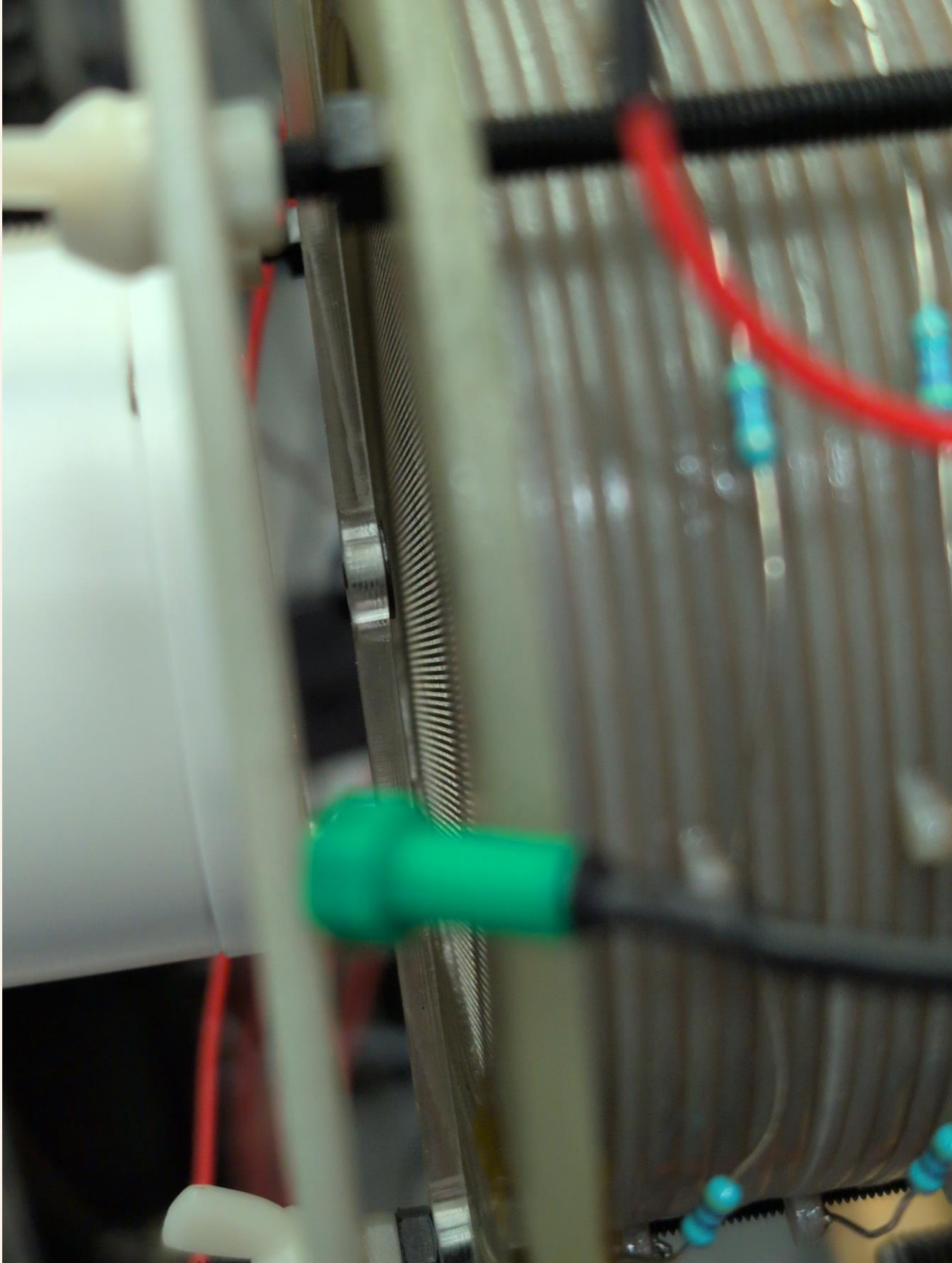
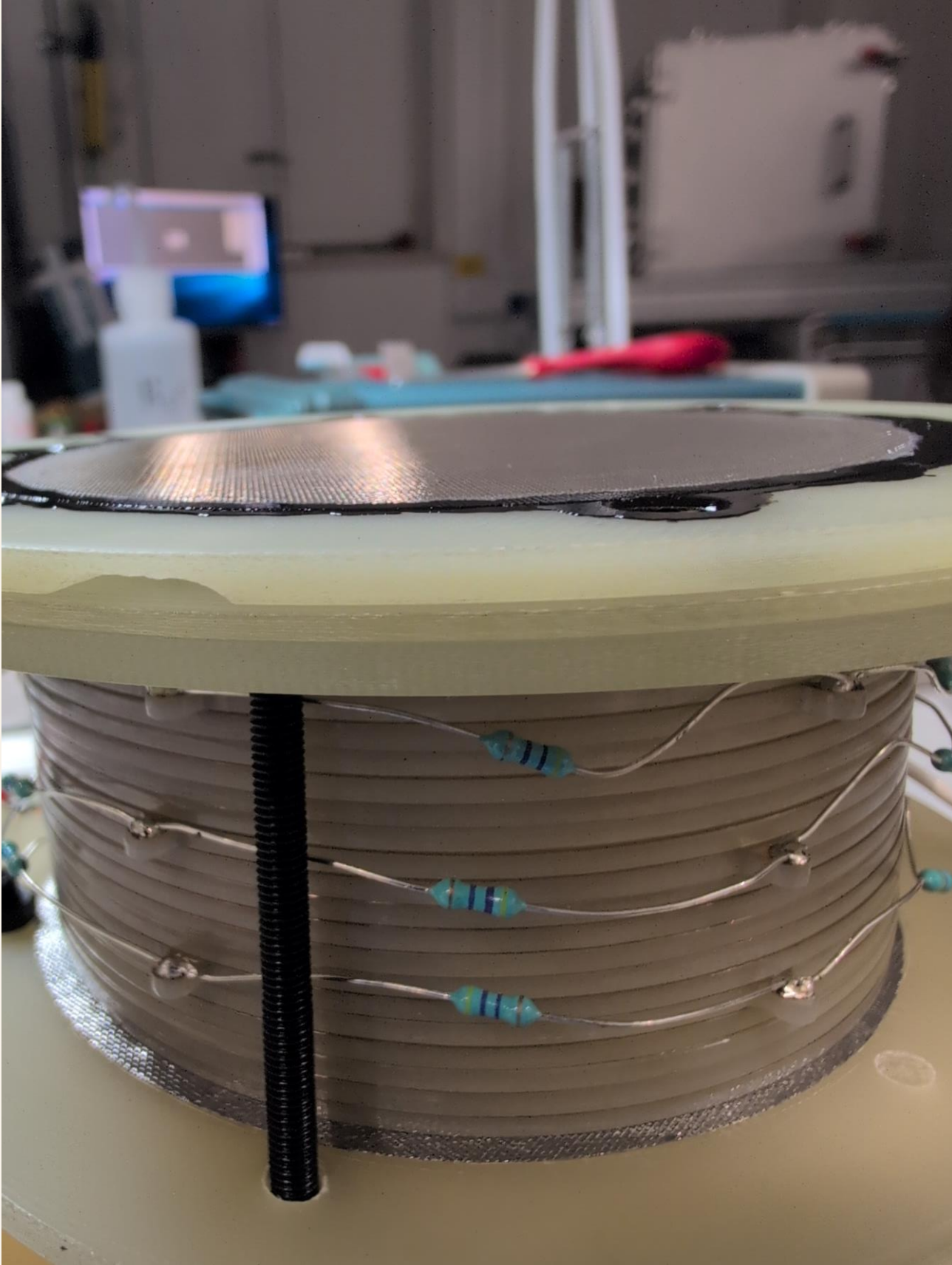

# Backup: 2-gap operation

