

# Commissioning and Calibration of SiPM based Camera for 4m Telescope

Bharat B. Singh

(On behalf of VHE Gamma Ray Astronomy Group)

DHEP, TIFR, Mumbai

Technology & Instrumentation in Particle Physics (TIPP2026), TIFR, Mumbai.

# Silicon-based Atmospheric Imaging Camera (SAICam)

Indirect detection of VHE gamma rays from the celestial sources  
**AIM:** Blazar monitoring



Laboratory Setup  
(2024)

Location: Mt Abu Rajasthan, (24°36'N, 72°47'E, 1300m asl)  
Astrophysical Science Division, BARC, Mumbai

# Design concept: Layout of 256 Pixels SiPM Camera (FoV =5 deg)

- Hamamatsu SiPM arrays (12.6mmx12.6mm)
- Spectral range (250 nm– 1000 nm)
- Dichroic filter
- Temperature dependent gain (3% change in gain per degC)

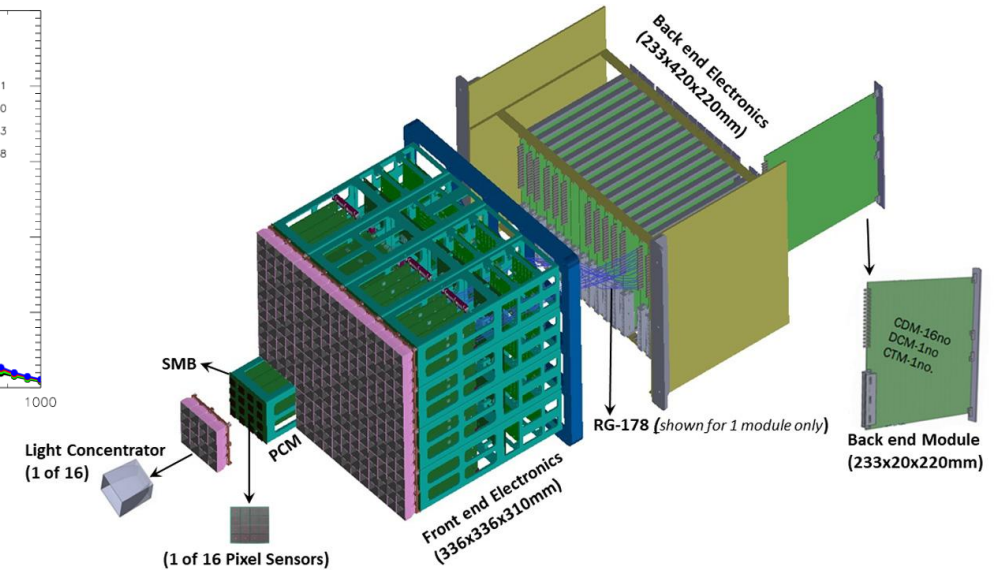
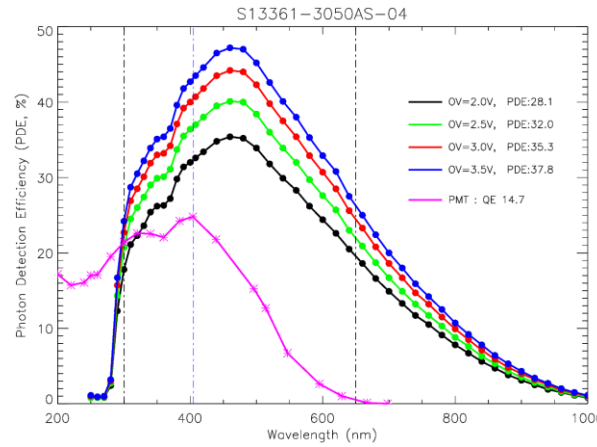

- Threshold Energy: 550-600GeV
- Dynamic range: 1500pe
- Detection sensitivity: *In progress*

$$S = \rho_{\gamma} A R \omega = n_{\gamma} E A R \omega$$

$$N = \sqrt{\varphi_{nsb} A \Omega R \omega \tau}$$

$$E_{th} \propto \frac{1}{n_{\gamma}} \sqrt{\frac{\varphi_{nsb} \Omega \tau}{A R \omega}}$$

# Calibration of SAICam

## Detector+Telescope

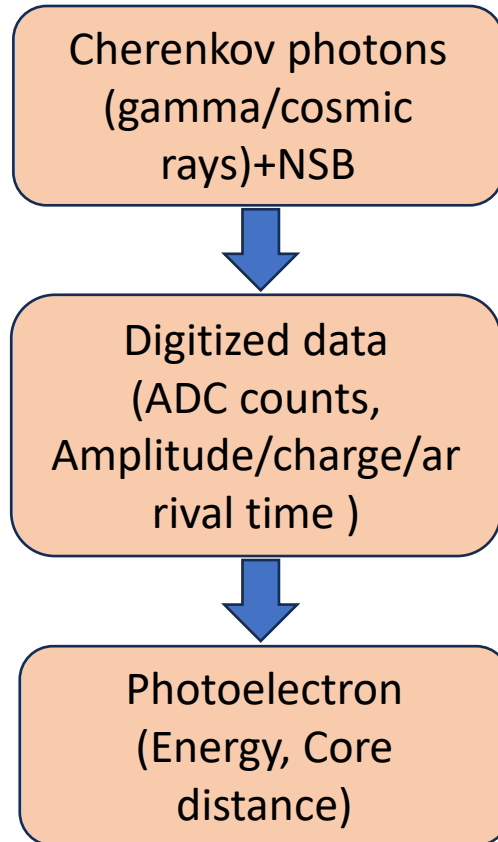

From measured events to a true astrophysical source

## Monte-Carlo Simulations

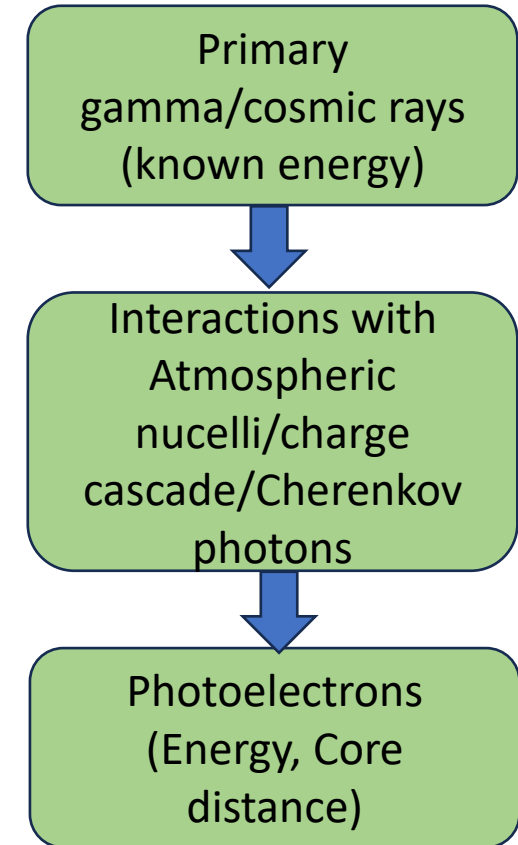

# Camera Calibration Box (CCB)

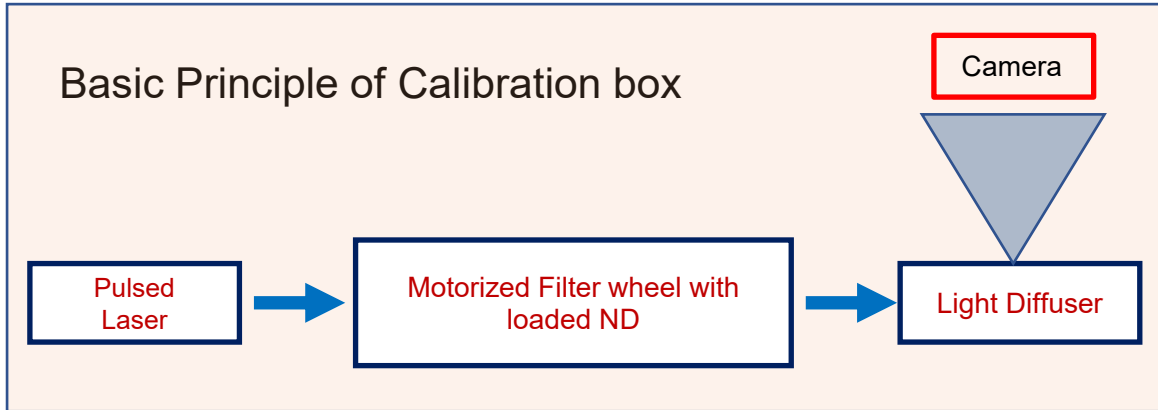

The calibration system produces fast and uniform light pulses at a wavelength range close to the peak of the Cherenkov spectrum. The light output requirements are 5-7 ns FWHM pulses ranging from 1pe to 1000pe.

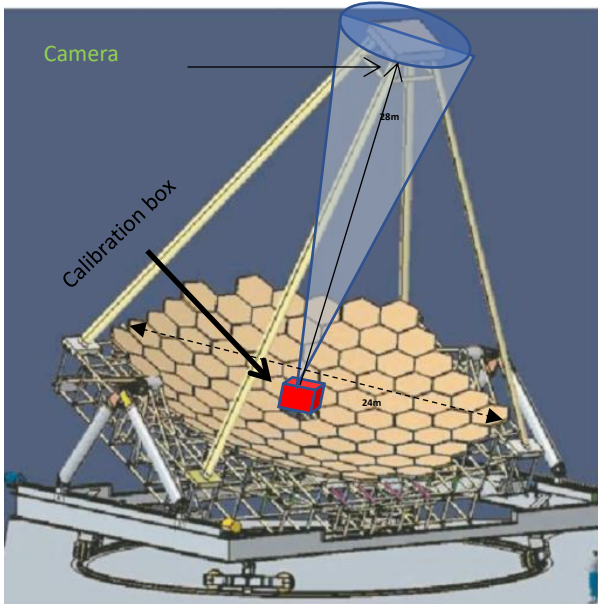

Light source	Diode laser (NPL41B)
Typical center wavelength	405 ± 10 nm
Pulse width	5ns to 39ns
Peak output power	75mW
Trigger	Internal/External
Max Rep. Rate	10MHz

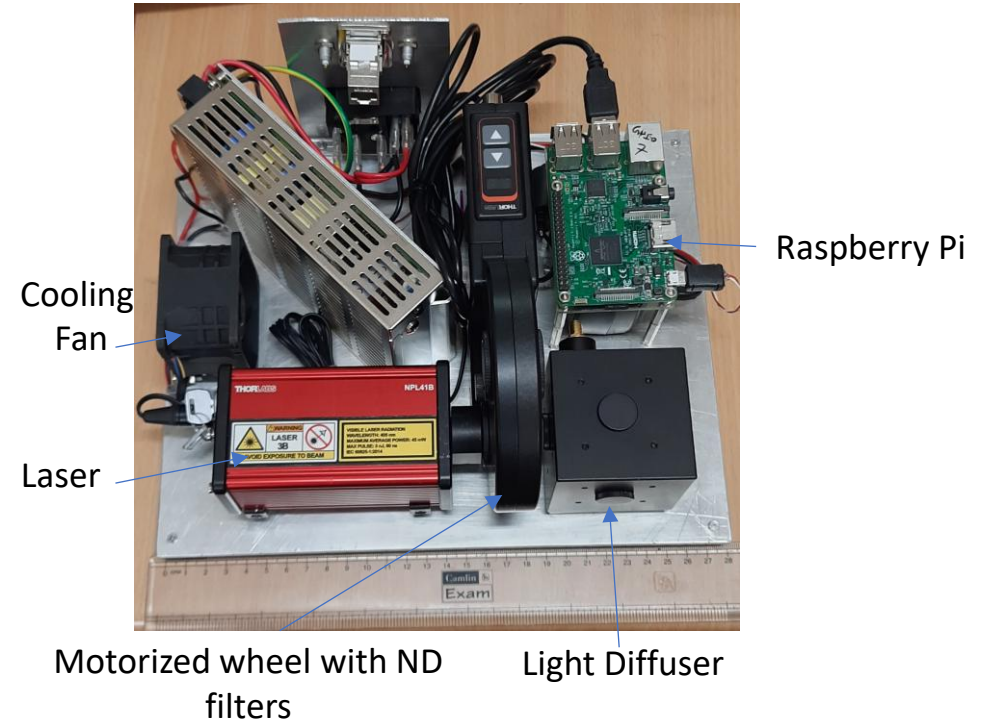

# Camera calibration: Test bench setup

Light source: monochromatic and coherent light source (405 nm and optical duration 6 ns)

- (a) Linearity of Light source and maximum photoelectrons
- (b) Uniformity of photons in the focal plane
- (c) Stability of light source

HM module (Ref)



- Base-line at 3.5-meter
- Minimum PE=1
- Maximum PE = 1000

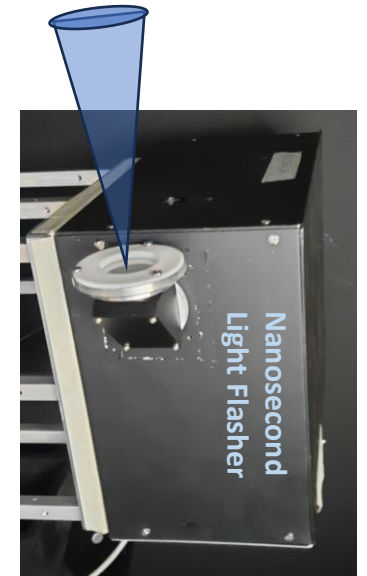
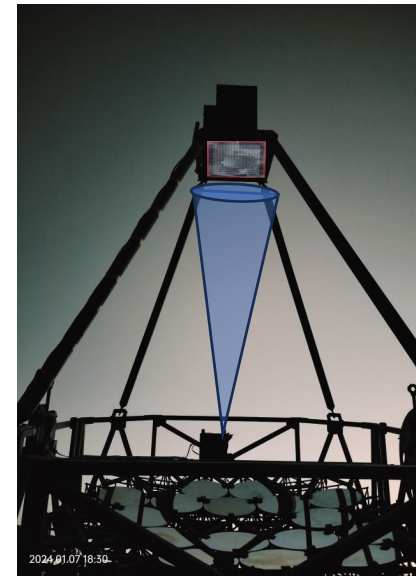
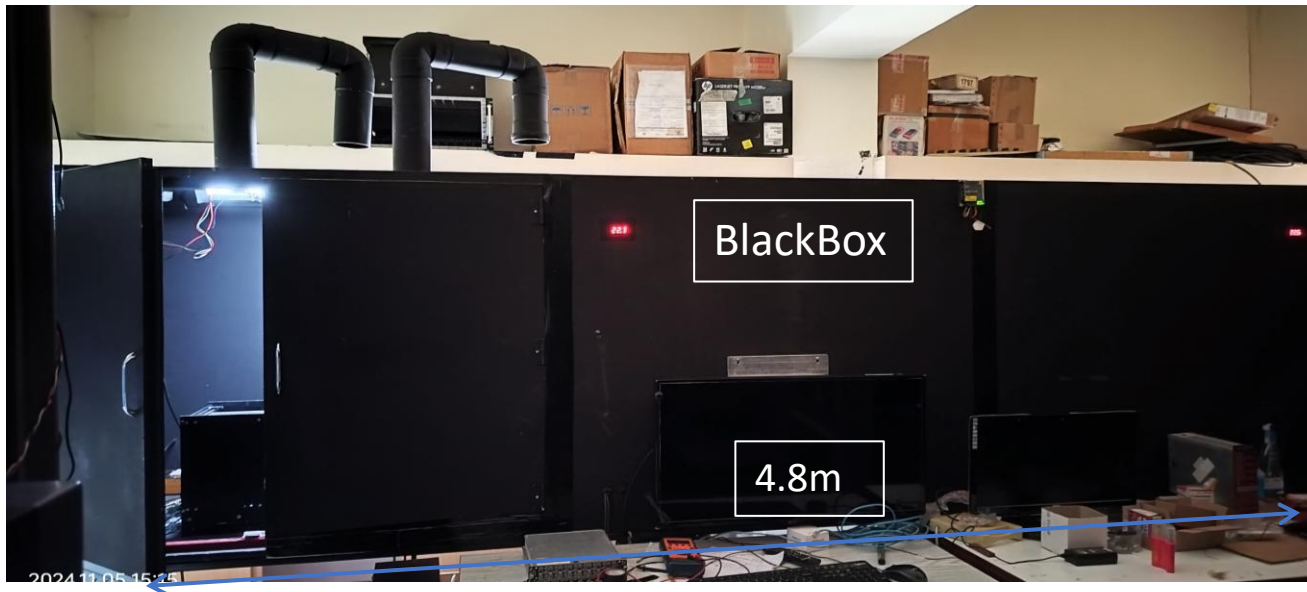
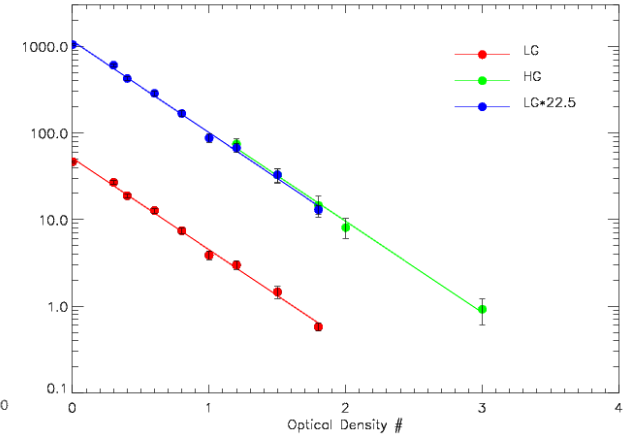
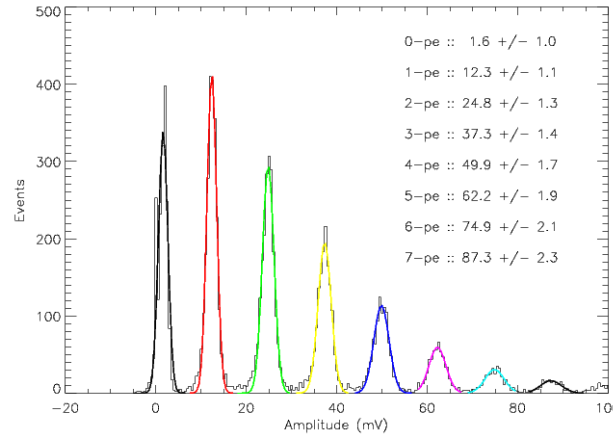

# Calibration and Optimization:

- 256 number of SiPM
  - Breakdown voltage
  - Temperature coefficient
  - Absolute gain
- Testing of the temperature bias model
- Efficiency Measurement of Light Concentrators
- Single Photoelectron map
- Time jitter
- Telescope-Camera response

# [1a] Characterization of SiPMs

**Breakdown Voltage** of a SiPM is defined as the minimum voltage at which the device begins to conduct current due to avalanche multiplication.

The breakdown voltage of a SiPM is dependent on temperature and increases with increasing temperature. The **temperature coefficient ( $\alpha$ )** of SiPM measures the change in its breakdown voltage or current gain per unit change in temperature.

$$V_o = V_{bias} - V_{BD}(T)$$

$$V_{BD}(T) = V_{BD}(25^{\circ}C) + \alpha*(T-25)$$

$$V_{bias}(T) = V_o + V_{BD}(25^{\circ}C) + \alpha * (T - 25)$$

$$Q = \frac{\int_{t_1}^{t_2} V(t)dt}{R}$$

$$G(V_o, T) = \frac{Q/g}{1.6 \times 10^{-19}}$$

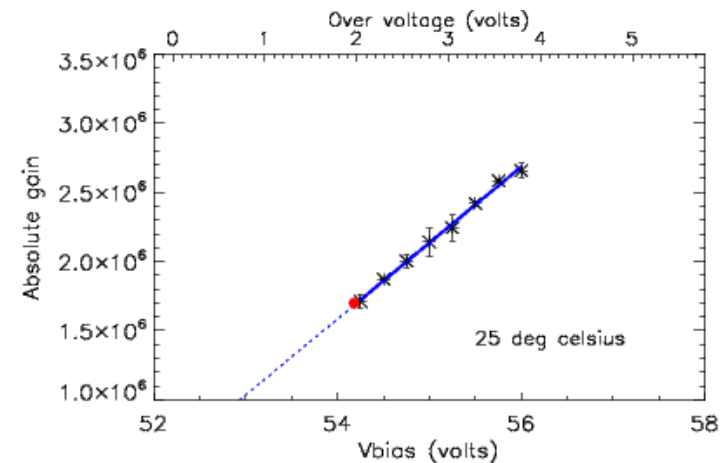
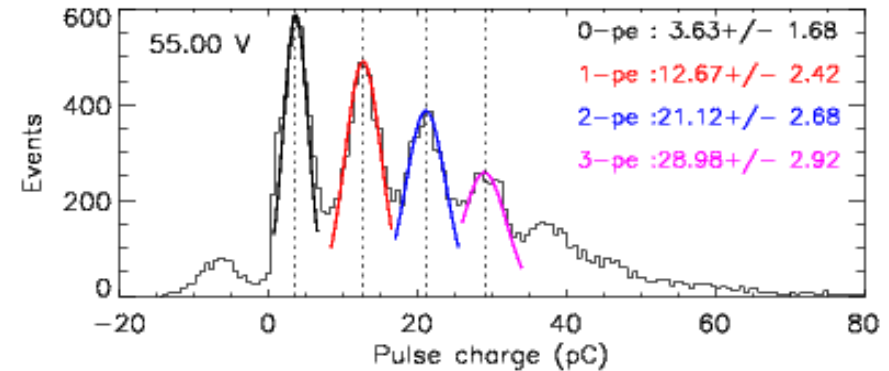
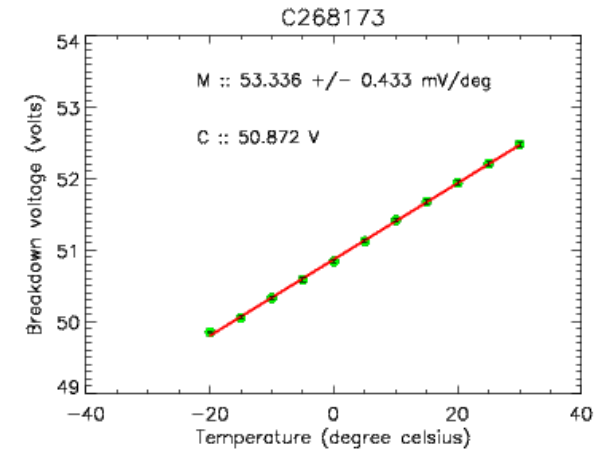
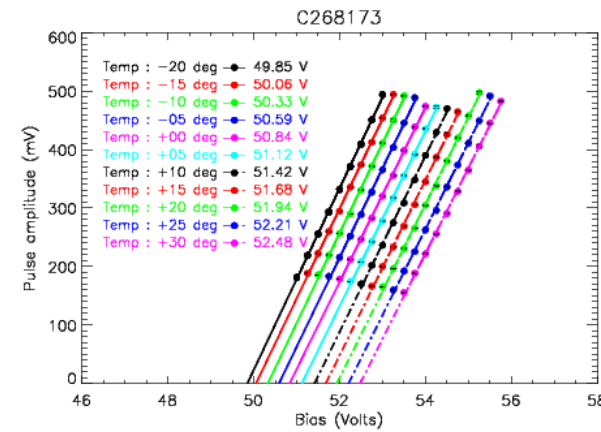

# [1b] Characterization of SiPMs

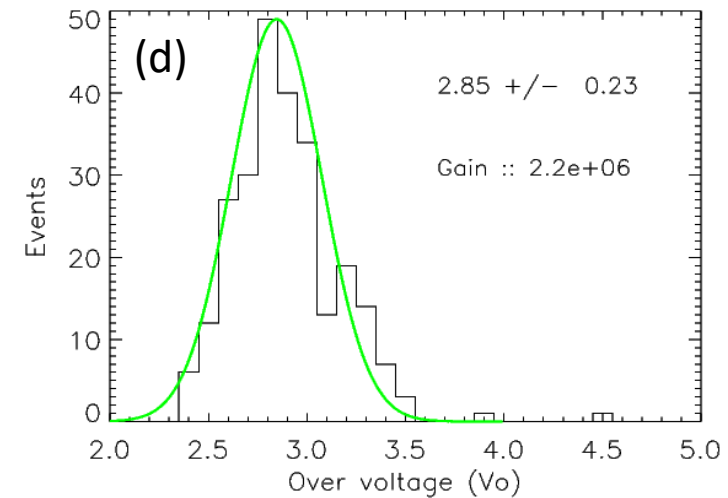
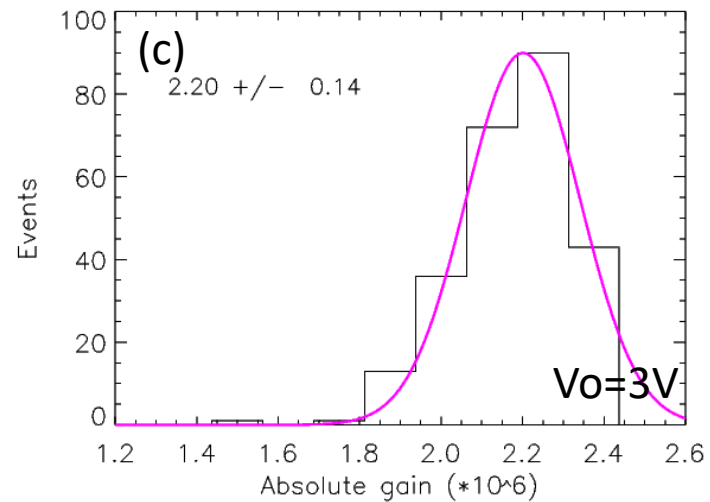
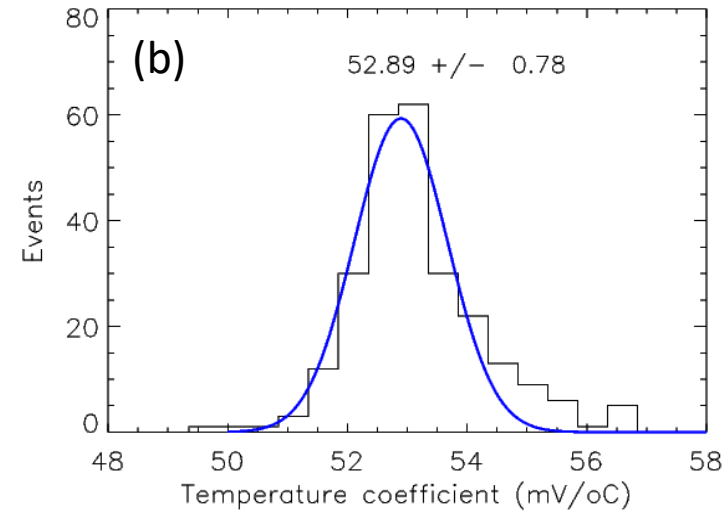
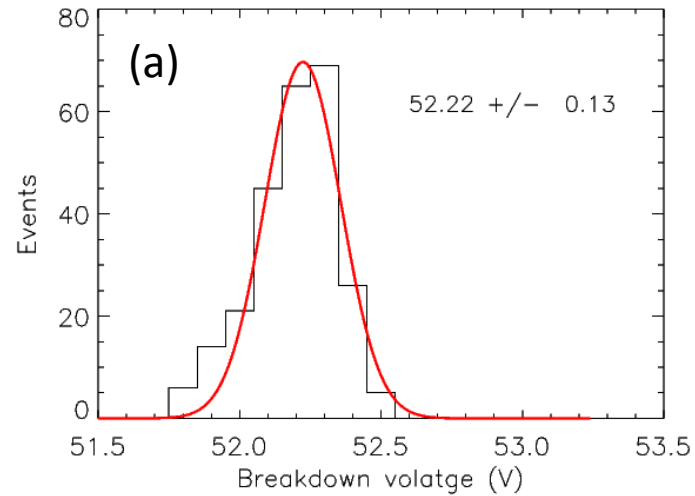

- Measured parameters:
- Breakdown voltage
  - Temperature coefficient
  - Absolute gain
  - Overvoltage

# [1c] Temperature gain stability

PCM coupled with light source

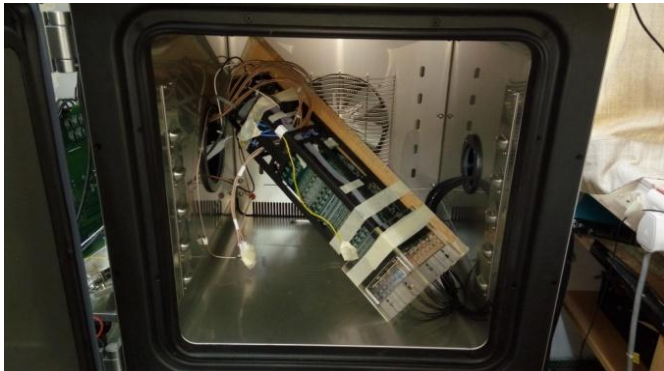

Environment chamber



-40°C to +150°C

$$V_o = V_{bias} - V_{bd}$$

$$V_{bd}(T) = V_{bd}(25^{\circ}C) + \alpha(T - 25)$$

$$V_{bias}(T) = V_o + V_{bd}(25^{\circ}C) + \alpha(T - 25)$$

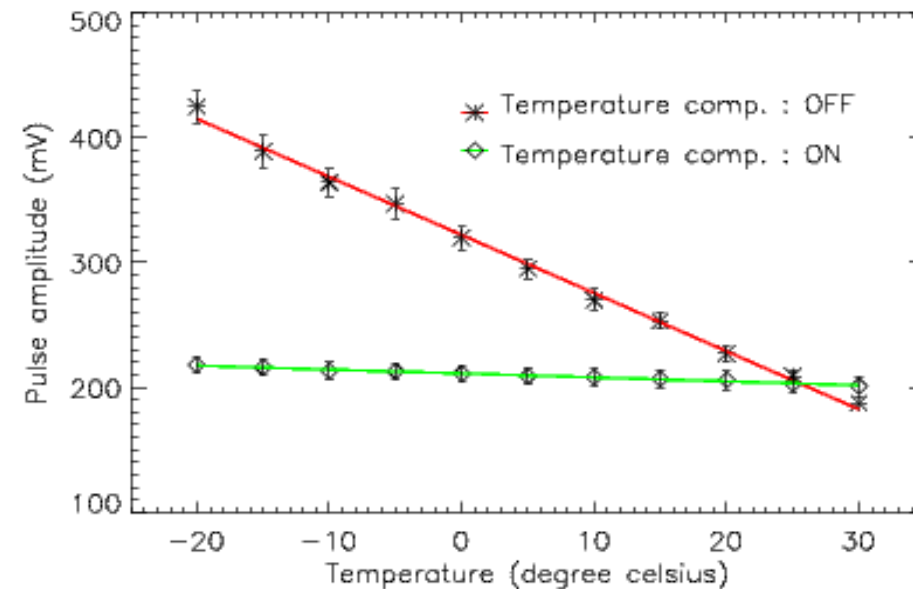

## [2] Light Concentrator

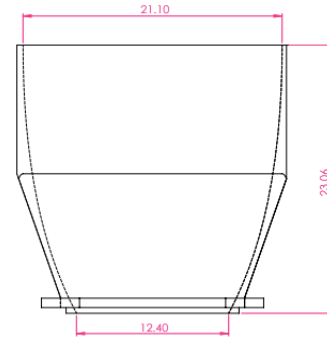
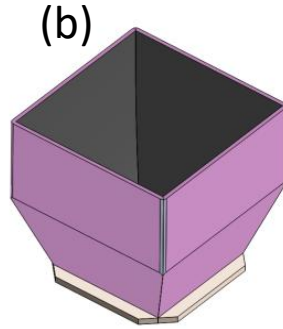
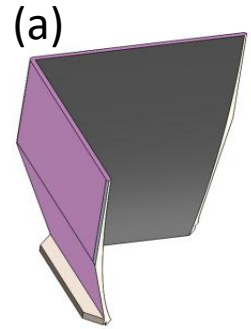

The compound parabolic concentrator (CPC) or Winston Cone (WC) is used to collect and concentrate distant light sources.

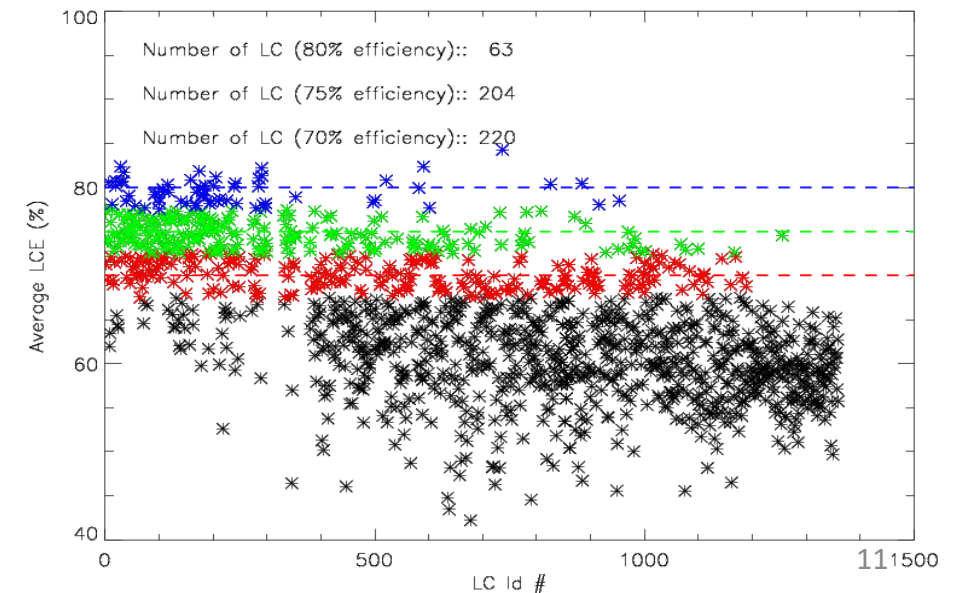
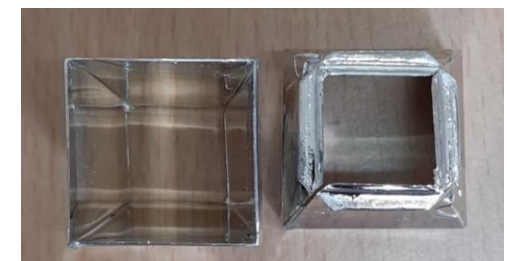
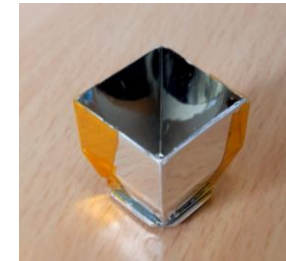
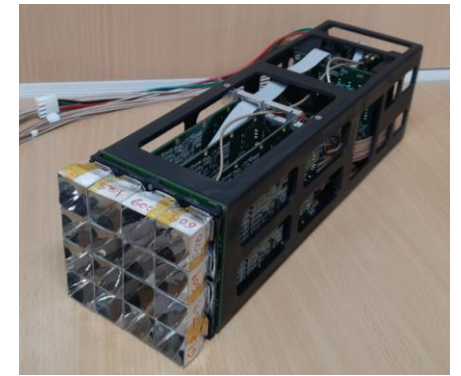
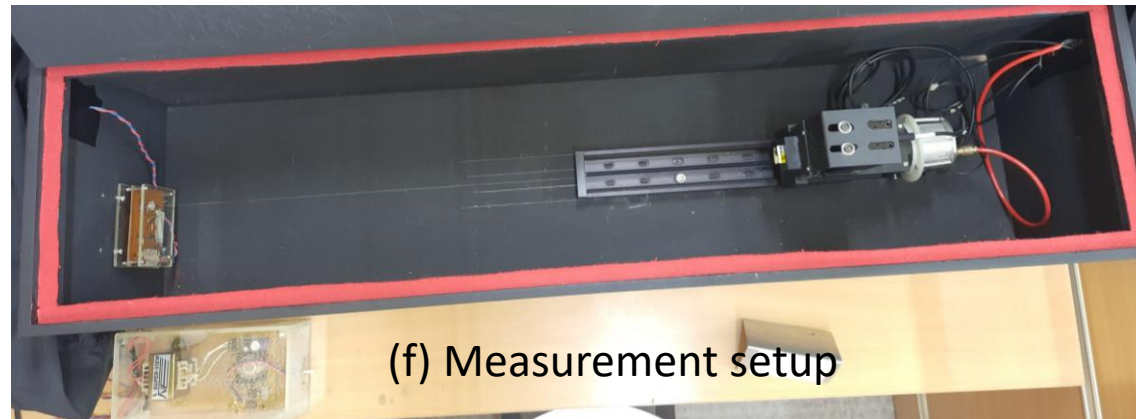

# [3] Data calibration: In-situ absolute calibration

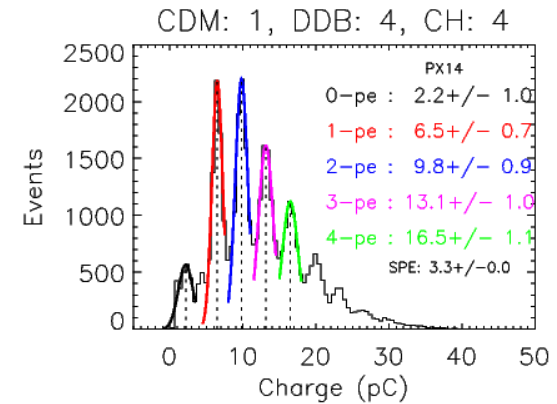
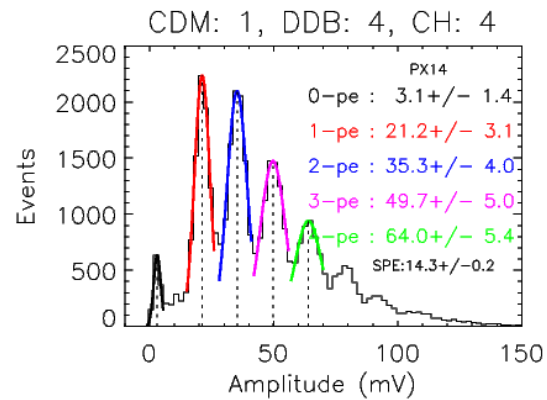
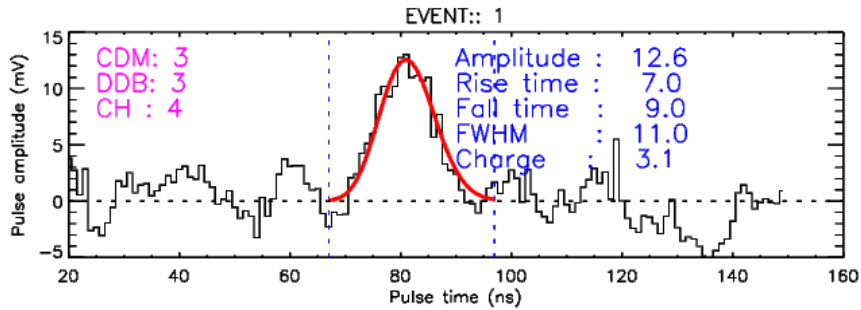
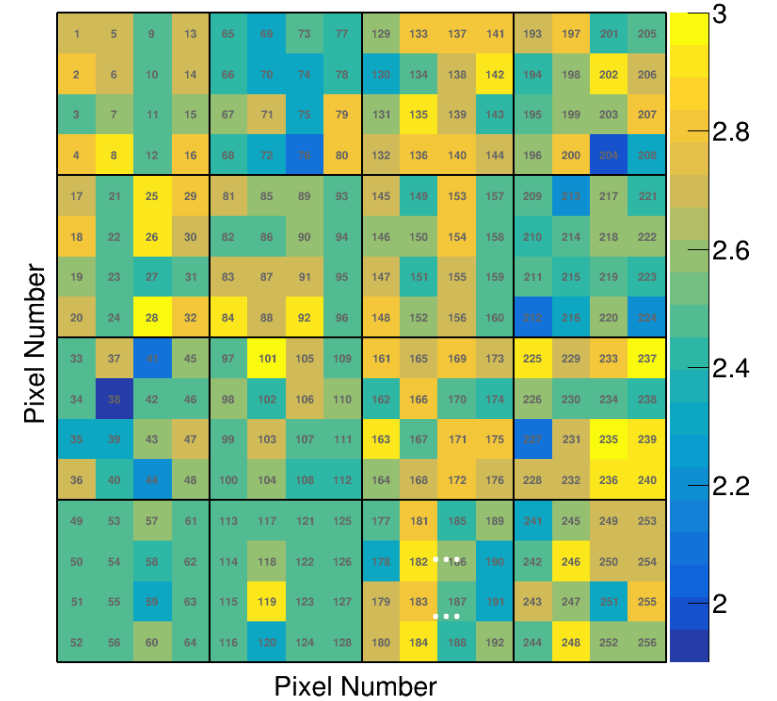
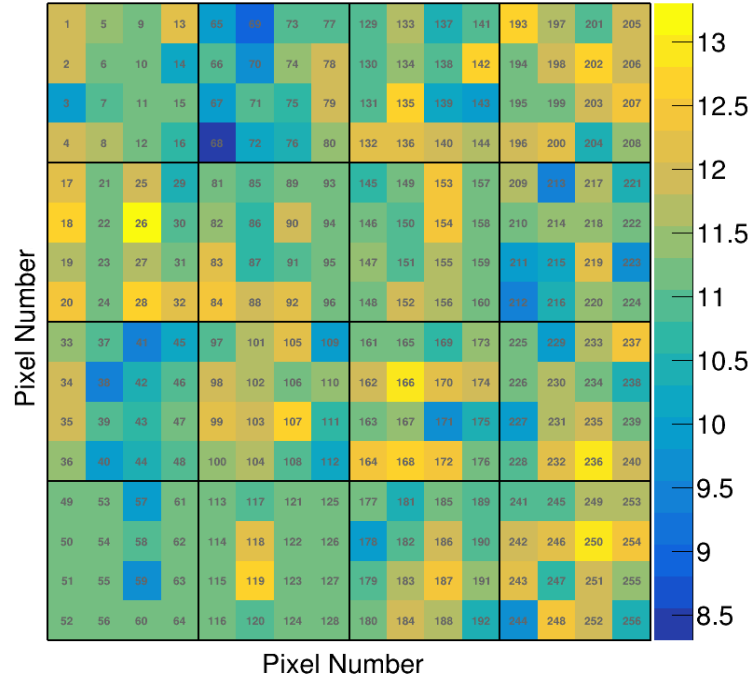
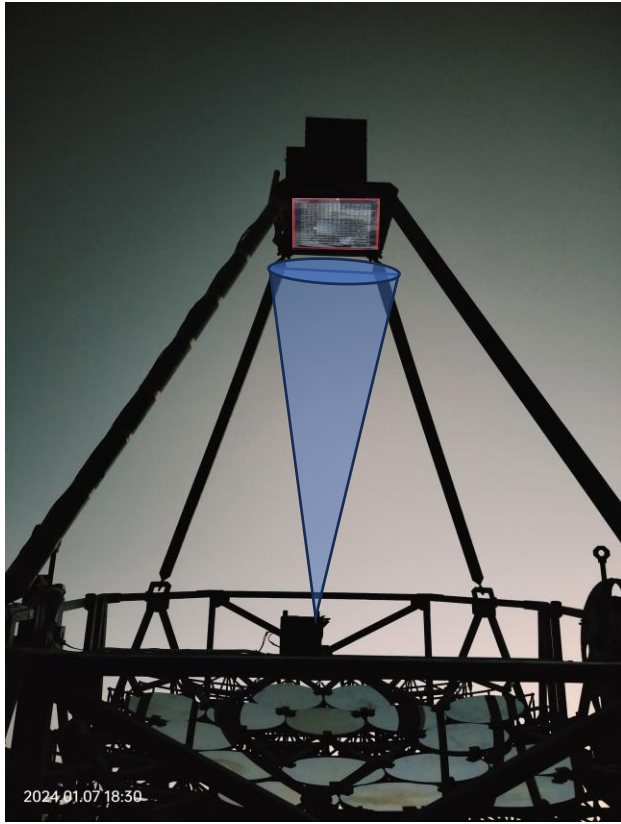

# [4] Data calibration: Uniformity & Relative arrival time

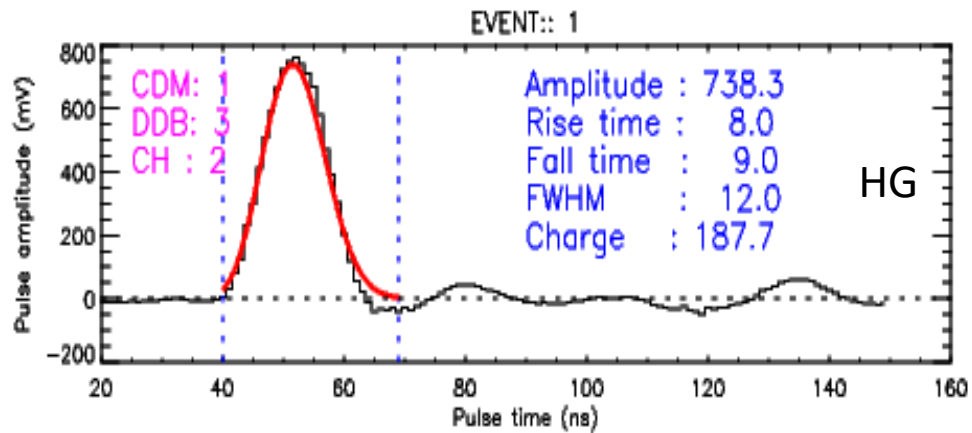
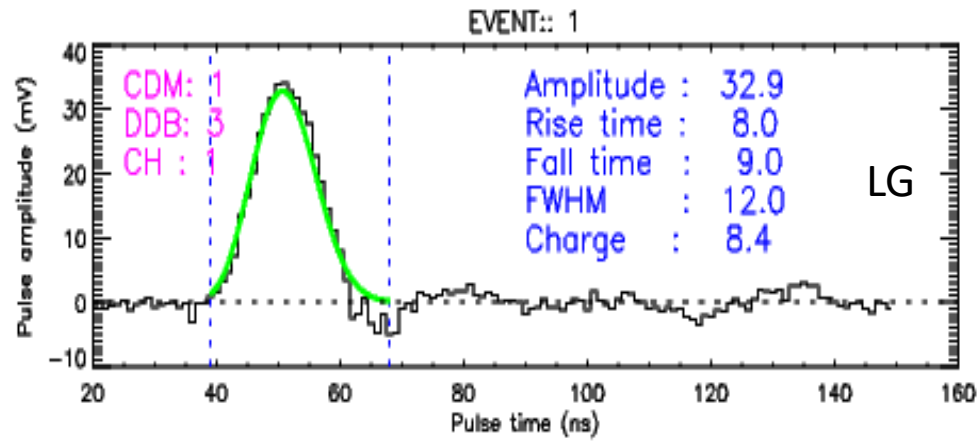

OD=15, Events=2500, Trigger Logic = 3NN

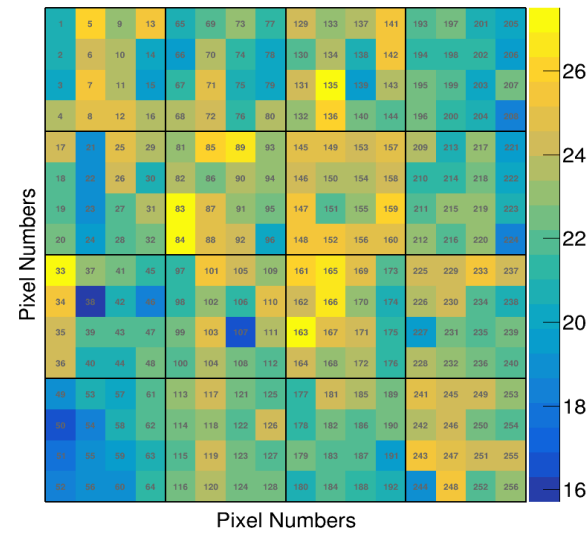

Mean pulse amplitude (mV) of LG channels

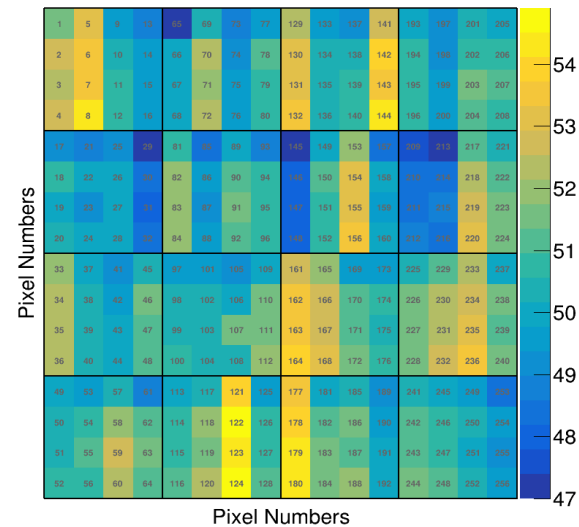

Mean pulse arrival times (ns) of LG channels

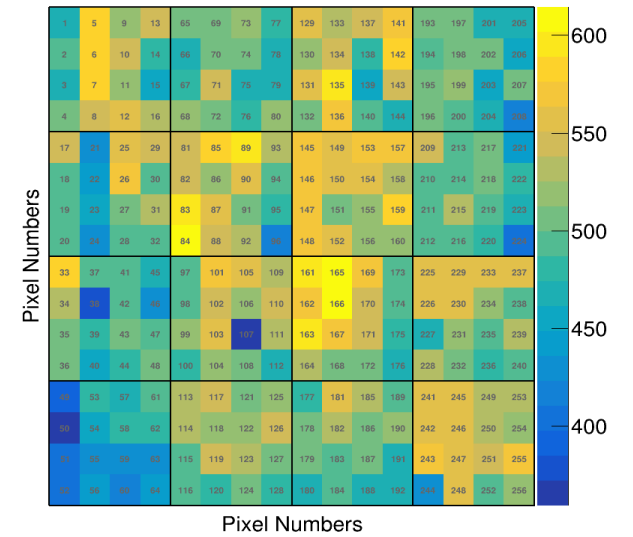

Mean pulse amplitude (mV) of HG channels

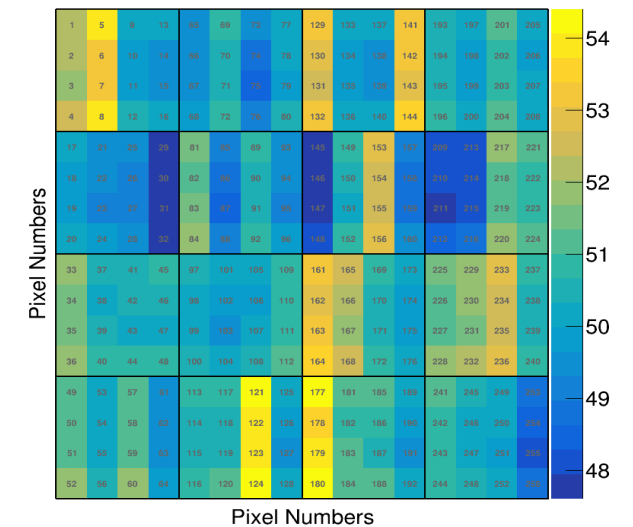

Mean pulse arrival times (ns) of HG channels

# [5] Camera Response: (a) Temp-gain stability (b) Pixel channel gain

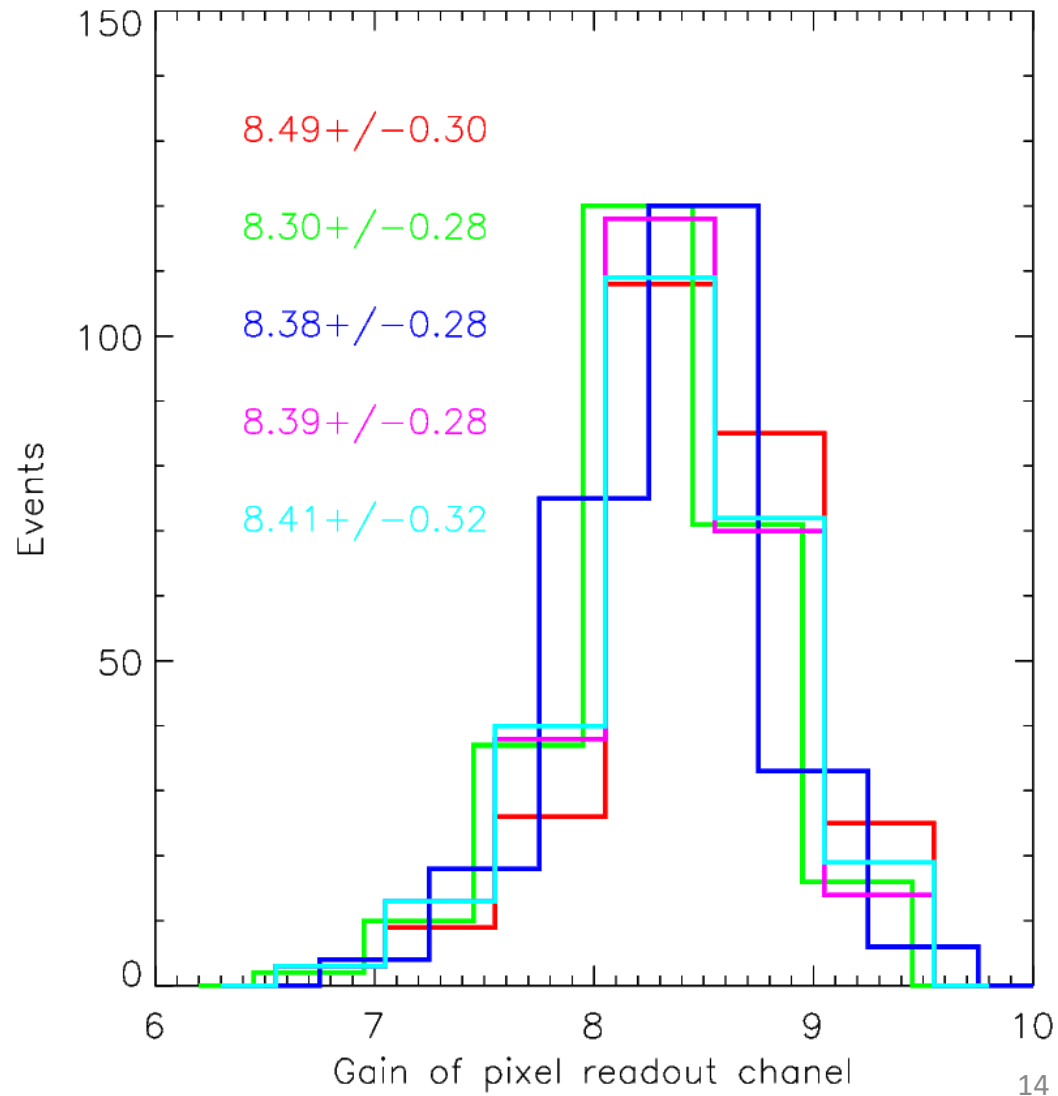
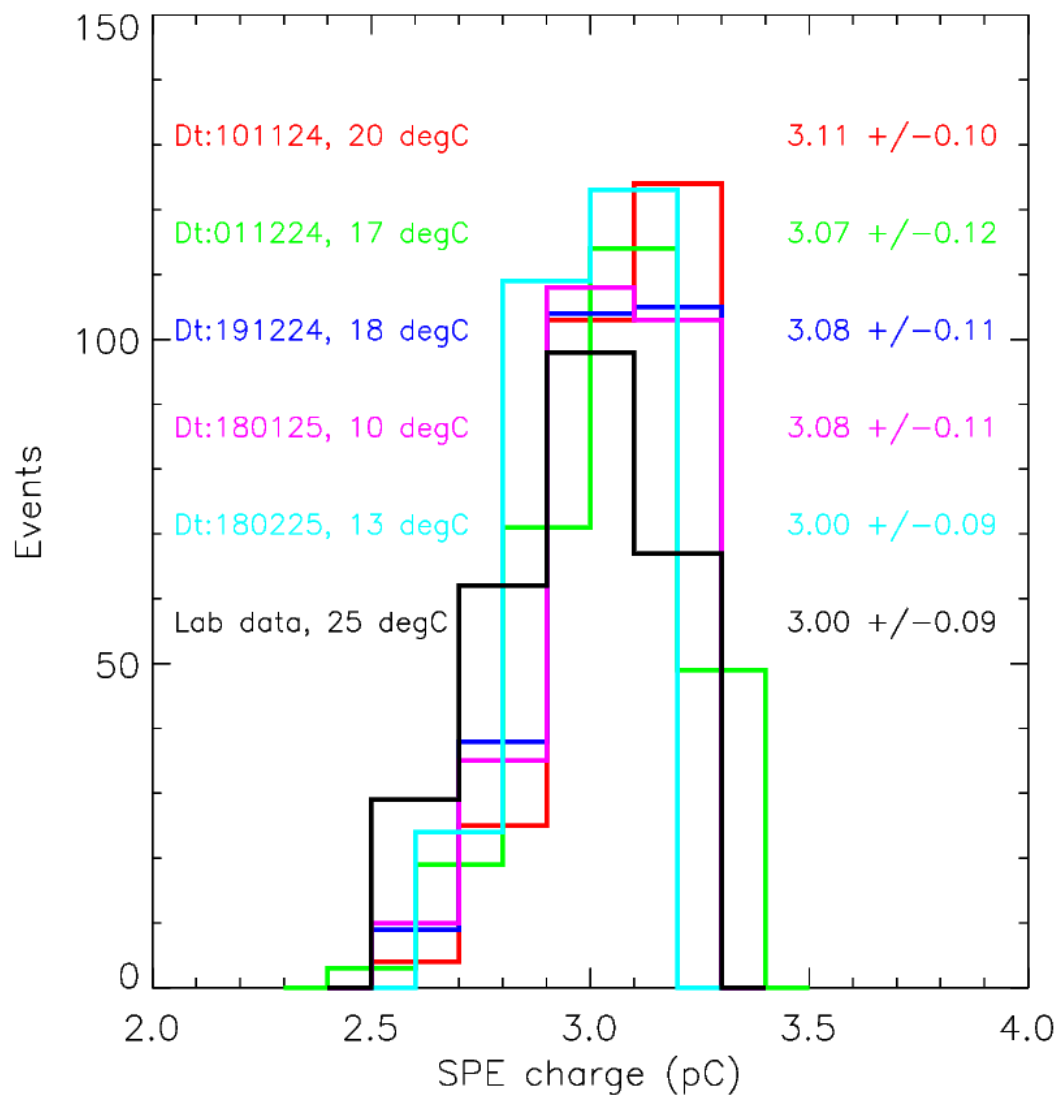

# [6] Camera Response:

- (a) DCR - Bias
- (b) Trigger rate – Bias
- (c) Operating bias (OV)

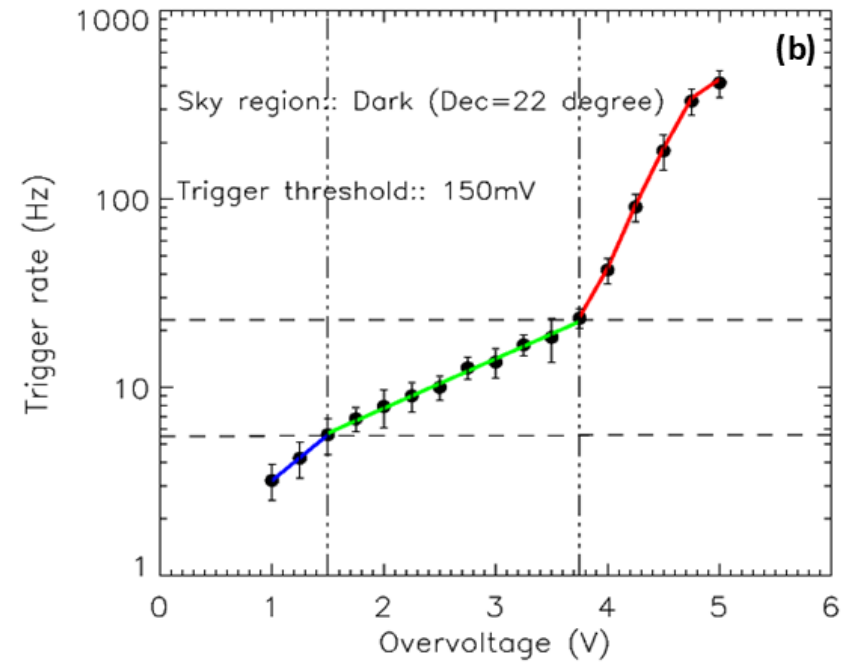
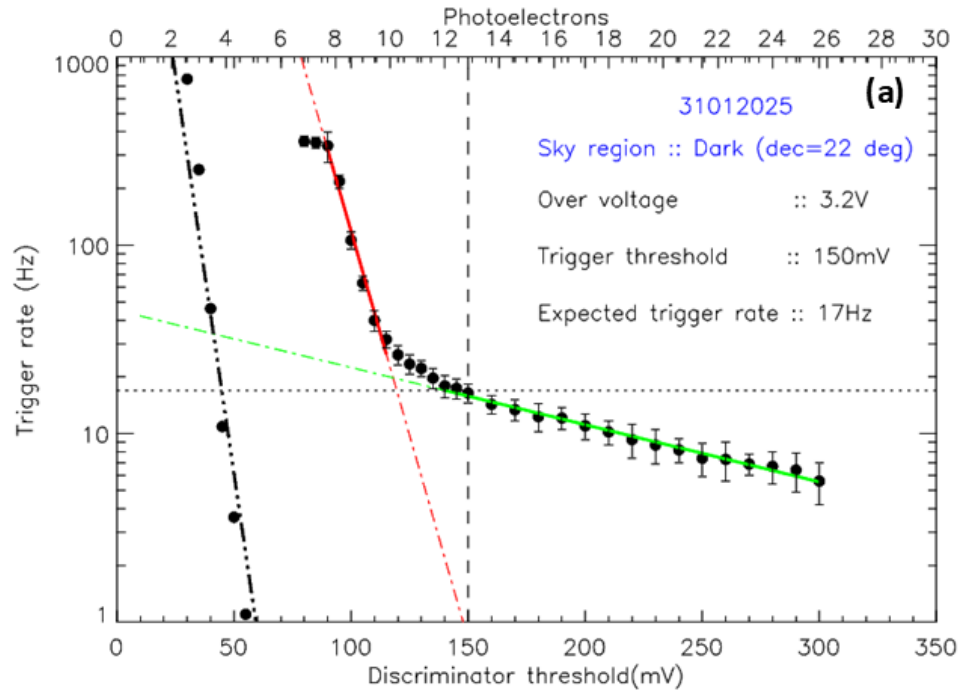
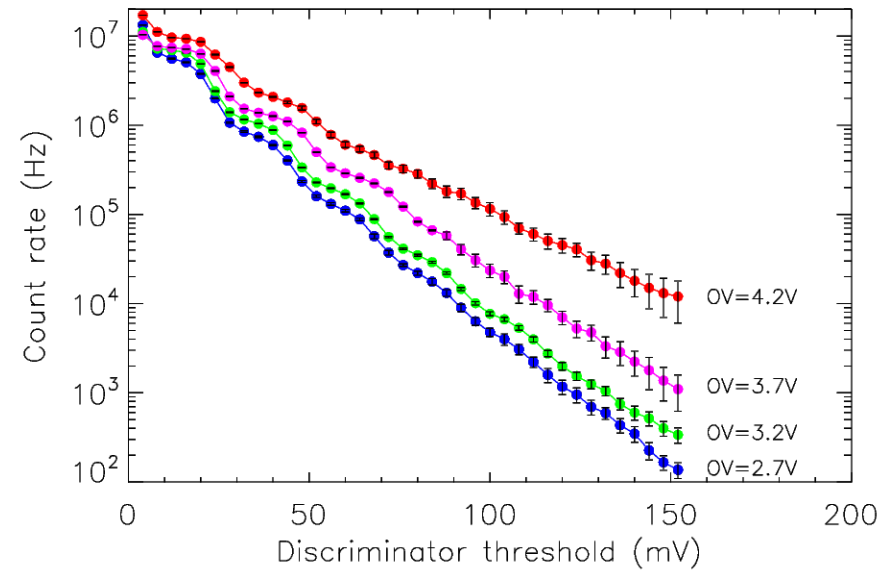

# Summary

- ✓ Calibration of photosensors
- ✓ Onsite field testing
- ✓ Temperature gain stability
- ✓ In situ SPE measurements
- ✓ Camera-Telescope response
- ✓ Observations of Crab-nebula
- ✓ MC simulations are progress
- ✓ Plan for more sensitive camera future array of telescopes

