

# Vision on picosecond timing device



**Nicolò Cartiglia**

*Istituto Nazionale di Fisica Nucleare, Torino (Italy)*

**TIPP2026, Mumbai**



# Vision on picosecond timing device

## TIPP

### **Technology and Instrumentation** in Particle Physics

Almost all new experiments, upgrades, and planned facilities use timing to reach their physics goals.

At the roots of these possible discoveries lies the work of all of us in developing new techniques.

This presentation follows the technological advances and their impact on experiments.

Good tools are the enablers: they make experiments possible

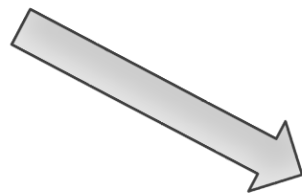

# The tools of the trade: 1990 - 2000

Almost all timing applications relied on:

- **Scintillator pads**
- **Photomultiplier tube** (PMT)
- **Electronics crates** (NIM, CAMAC, VME)

1. A MIP passes through a **scintillator**,
2. A burst of photons reaches the **PMT**
3. PMT creates an analog pulse,
4. The signal is digitized by **discrete electronics in crates** (NIM/VME).

They were **bulky systems**, required high voltage (kV), and were **sensitive to magnetic fields**.

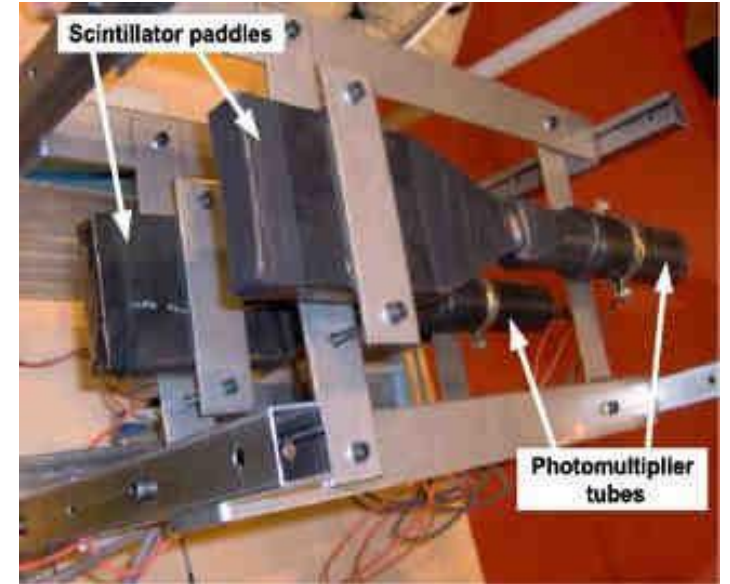



# Scintillators + PMT

**Timing was historically used for three main functions:**

1. Particle Identification (PID) via Time-of-Flight (CDF-II)
2. Background & Pile-up Rejection (NA48, kTeV)
3. Event selection, triggering (AMS-02)

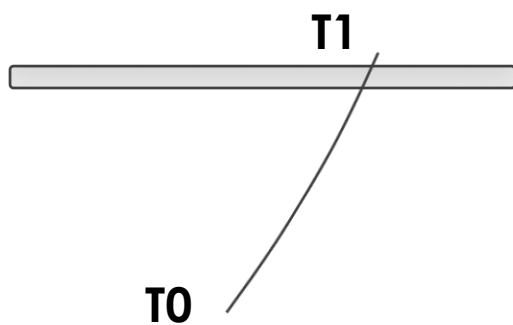

**1: time of flight**

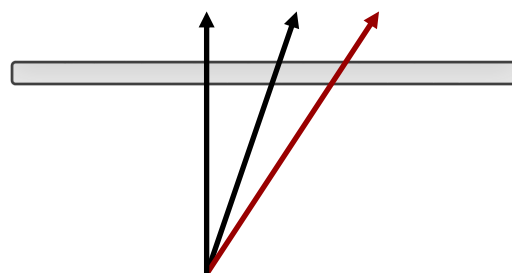

**2: Pile-up, veto**

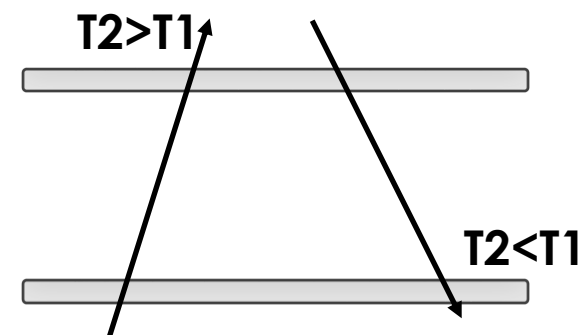

**3: Down- vs up-going**



# PMT + Scintillator systems

## The TOF-Detector

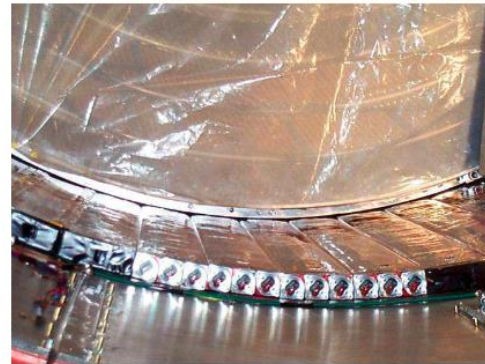
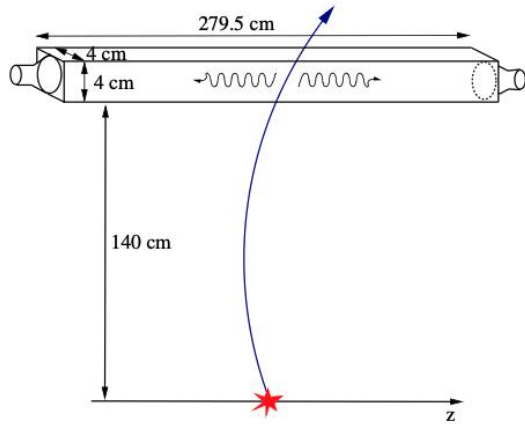

CDF Time-of-Flight system

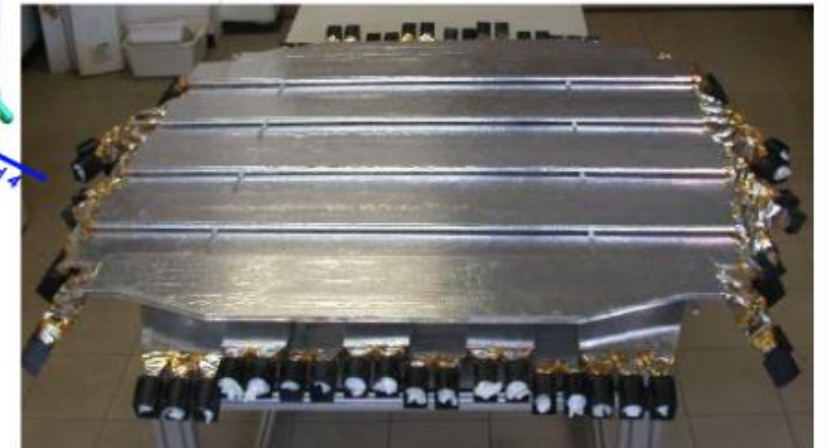
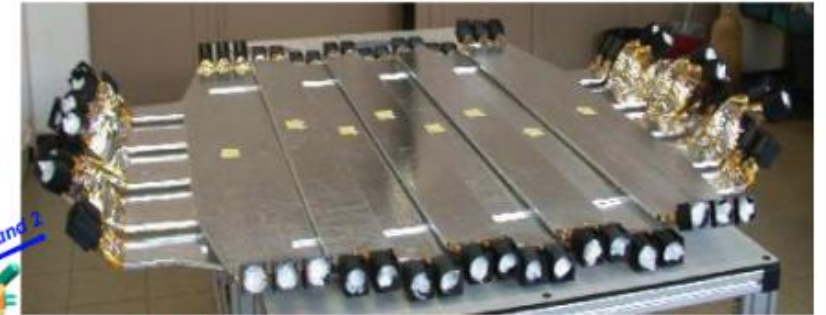
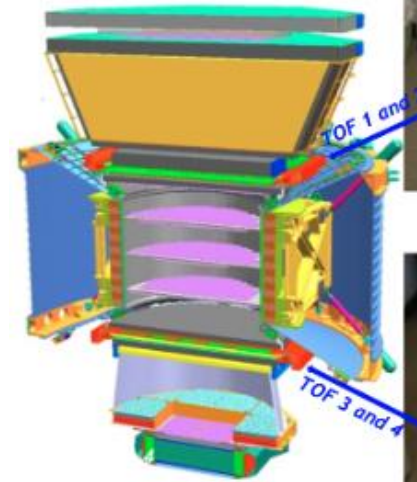

AMS Time-of-Flight system  
It already uses ASICs for readout!



# Scintillators & PMTs Systems

System	Technology	Area / Scale	Channel Count	Resolution track
<b>CDF II (2001)</b>	Scintillator	~24 m <sup>2</sup> (radius 1.4m)	432	~100 ps
<b>AMS-02 TOF (2011)</b>	Scintillator + PMT+ASICS	~1.2 m <sup>2</sup> per plane	~144 PMTs	~160 ps
<b>Belle TOF (1999)</b>	Scintillator	128 scintillator (radius 1.2m)	256	~ 100 ps
<b>NA48 Hodoscope (1997)</b>	Scintillator	~4.5 m <sup>2</sup>	~400	~200–250 ps

**1-25 m<sup>2</sup>, < 500 PMT, 100-200 ps**



# Masterclass in PMT: the Kamiokande experiments

In a water Cherenkov detector, **timing is not just an auxiliary measurement—it is the primary tool for spatial reconstruction.**

By comparing the relative timing between different PMTs, the system triangulates the **interaction vertex** (where the neutrino hit) and the **direction** of the particle.

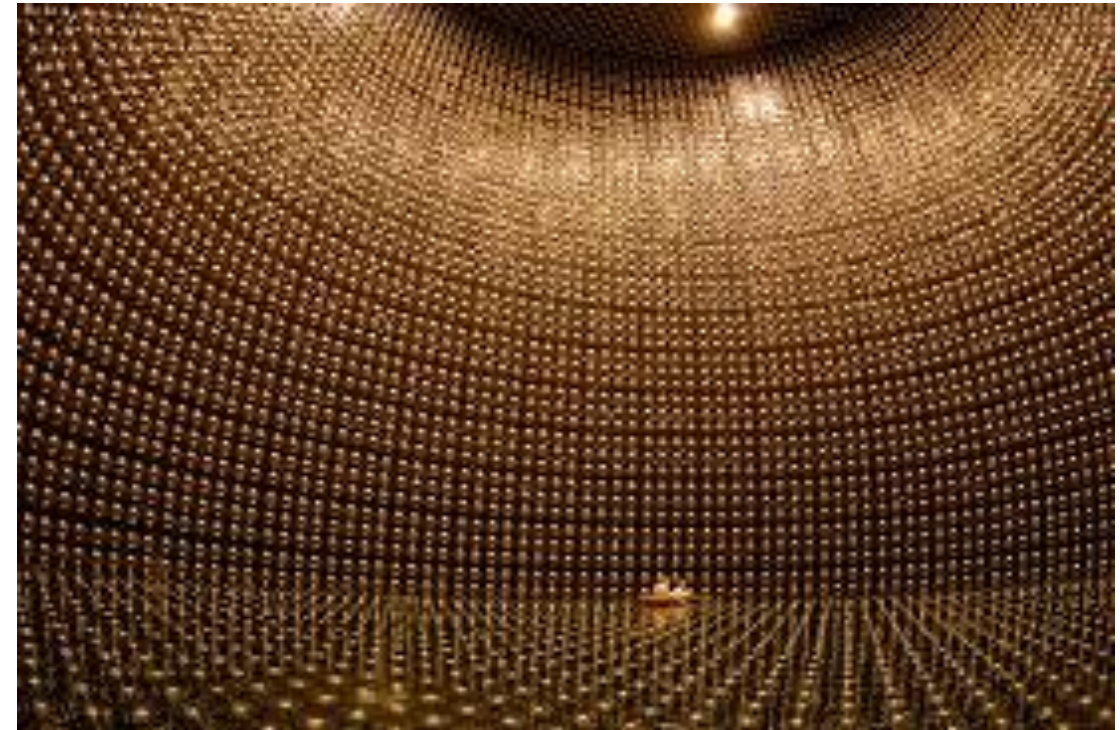

System	Technology	#PMT	Timing Precision
Kamiokande II (1987)	20" PMTs	~ 1000	~4 ns
Super-K (1996)	20" PMTs	~ 13000	~3 ns



# The Gaseous Timing Family: MRPC

## The ALICE experiment needed a TOF system:

- Very large, 140 m<sup>2</sup>
- Highly pixellated, 150,000 cells
- Low material budget
- Within their budget
- < 100 ps resolution

The **Multigap Resistive Plate Chamber (MRPC)** uses layers of glass plates (resistive) separated by thin gas gaps. When a charged particle passes through, it creates an electron avalanche in the gas.

**Electronics:** the **NINO ASIC**, an ultra-fast front-end amplifier/discriminator, followed by the **HPTDC** (High Performance Time-to-Digital Converter).

**Scintillators + PMT + Crates**  
did not meet these  
requirements

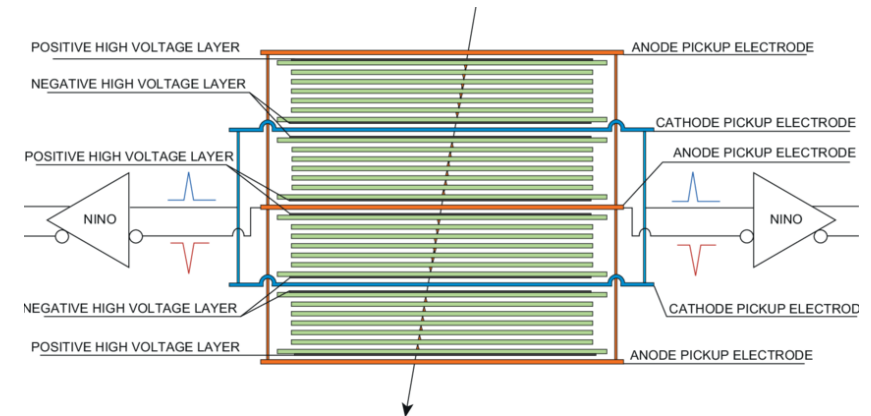



# The Cherenkov Timing Family: DIRC and TOP

**The BELLE and BABAR experiments required a TOF-based PID system:**

- It has to fit into a narrow space
- Allow for pion/kaon separation
- Very low material budget



## **BELLE II TOP (Time of Propagation)**

The TOP system measures the **Time of Arrival** and the **Impact Position** to reconstruct the Cherenkov angle.

**Pions are slightly faster than Kaons.** This means their **Cherenkov photons are emitted at a slightly different angle**. Because the angles are different, **a photon from a Pion might take a shorter path** (and arrive sooner) than a photon from a Kaon.

**The Measurement:** By measuring the arrival time with a precision better than **50 picoseconds**, the system can work backward to determine which type of particle created the light.



# Gaseous and Cherenkov Systems

System	Technology	Area / Scale	Channel Count	Precision track
<b>BaBar DIRC (1999)</b>	Quartz Bars	144 Bars 4.9m long	~11,000	~150 ps
<b>Belle II TOP (2019)</b>	Quartz Plate	16 Modules (radius 1.2m)	~ 8,200	~100 ps
<b>ALICE TOF (2008)</b>	MRPC	141 m <sup>2</sup>	~153,000	~80 ps

**Very large, lots of readout channels, 80-150 ps**



# A scaling problem

---

**PMTs + scintillators + NIM racks, gaseous and Cherenkov detectors are bulky,**  
they have intrinsic limitations on how they can be used.

The next generation of experiments required a channels density and granularity  
that cannot be obtained with these tools.

**A new generation of detectors became necessary...**



# The Silicon Timing Revolution

**SiPM, LGAD, and timing ASICs** are the three pillars of the latest generations of timing detectors.

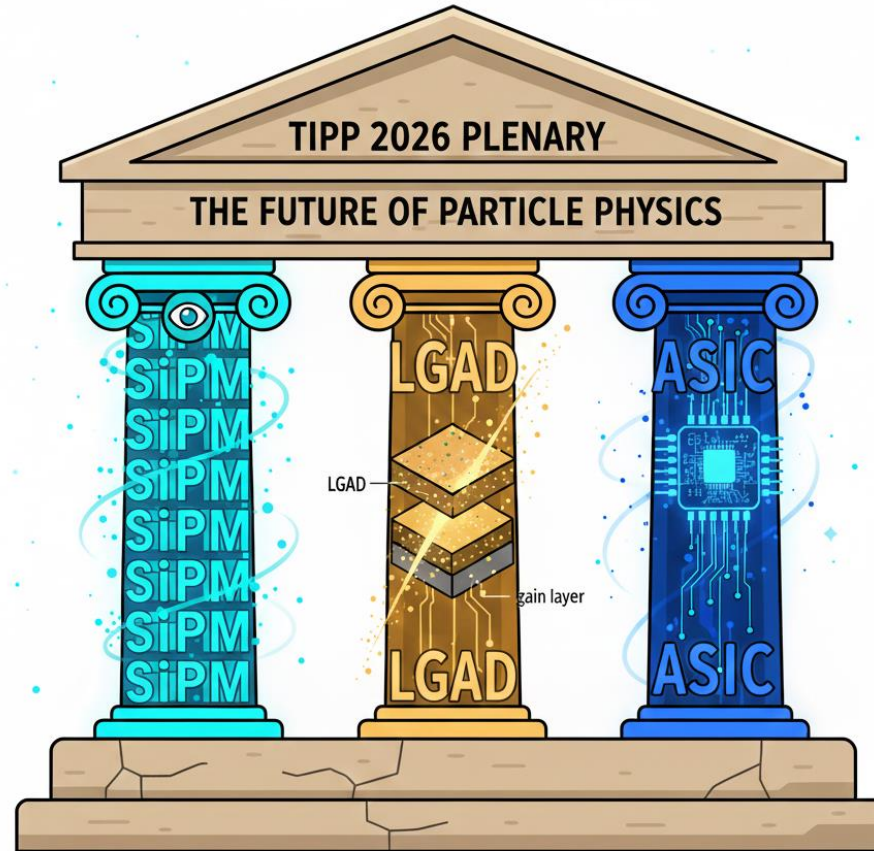

**SiPM: THE SOLID-STATE PMT**  
1990s–2010s

**LGAD: THE 4D TRACKING ENGINE**  
2010s–2020s

**ASIC: THE "BRAIN" ON CHIP**  
2020s–2020s



# Silicon Photomultiplier: the perfect photon detector

An array of thousands of microcells (Single Photon Avalanche Diodes - SPADs) operating **Geiger Mode** creates an analog signal proportional to the number of incident photons

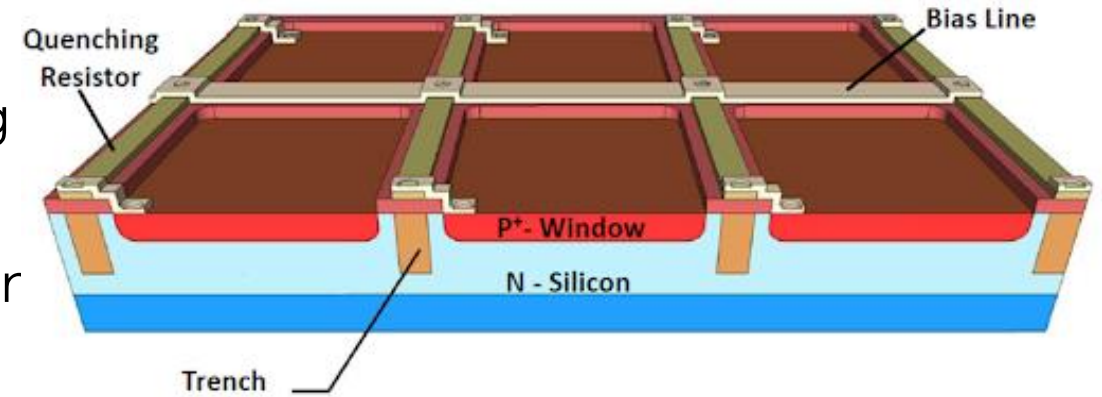

## They achieve everything you always wanted:

- Replace bulky, fragile PMTs with millimeter-scale chips.
- Operate perfectly inside high magnetic field
- Replace high voltage (1- 2 kV for PMTs) with low voltage 30 - 60 V

# SiPM + Crystal systems: Cherenkov and scintillation lights

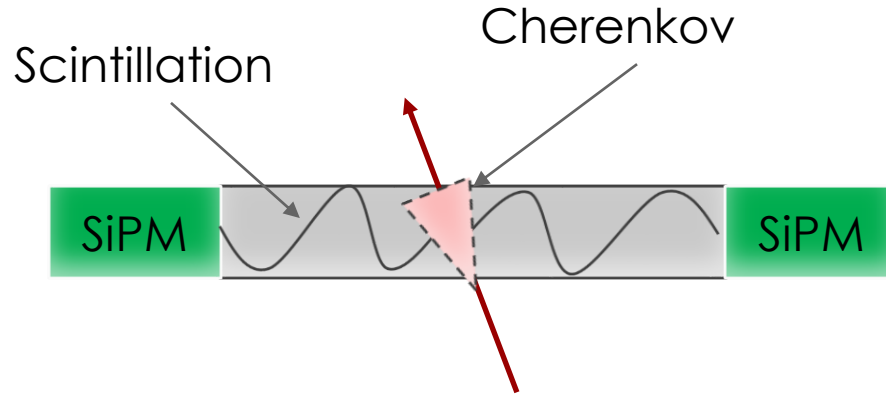

- Scintillation light bounces to the SiPM.
- Cherenkov light is lost
- Light is delayed

**Worse temporal resolution, more light**

**Note:** you can also use the **Cherenkov light generated in the SiPM package**

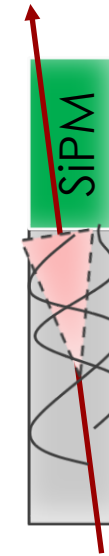

- Scintillation light bounces to the SiPM
- Cherenkov light arrives directly to the SiPM.
- Light is prompt and delayed

**Better temporal resolution, less light**





# Low-Gain Avalanche Diode: the perfect MIP detector

**LGADs (UFSD) are the enablers of excellent temporal resolution for charged particles, the equivalent of SiPM for photons.**

By keeping the gain low (10-30), they provide very fast current pulses with enough charge (5 – 20 fC) and excellent Signal-to-noise ratio.

They can be manufactured in small and large pixels, and in long and short strips.

They are radiation resistant up to  $\sim 2E15$  n/cm<sup>2</sup>

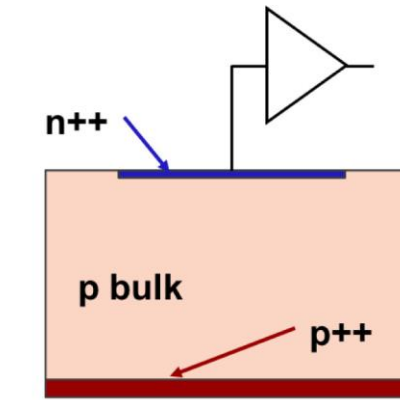

Traditional silicon diode

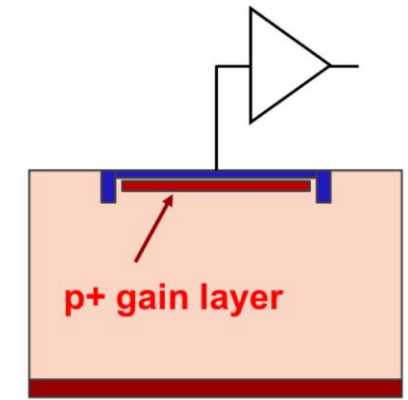

Low Gain Avalanche Diode

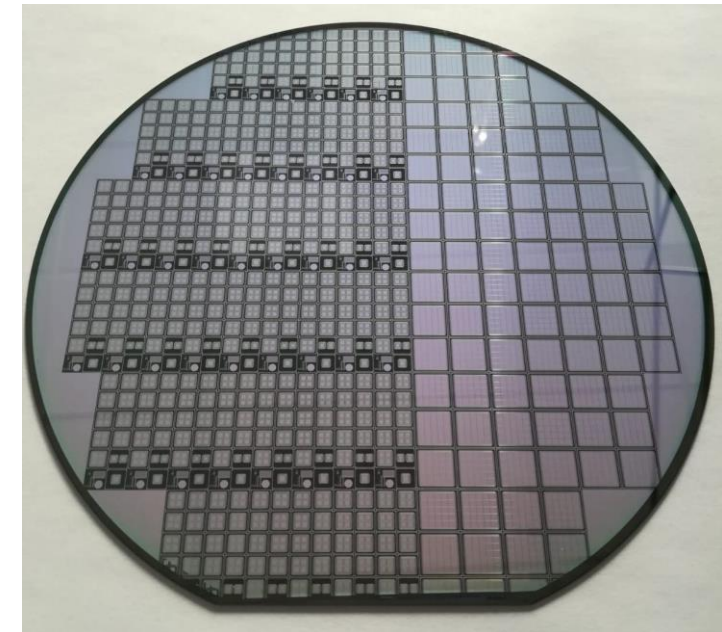



# Resistive Silicon Detector (RSD, AC-LGAD)

RSD (a spin-off of the LGAD idea) use charge sharing among electrodes to identify the hit position.

This concept allows **reducing the number of readout channels, saving power and reducing complexity**, while maintaining the same spatial and temporal resolution of “traditional” UFSD.

$$S_i \propto \frac{1}{Z_i} / \sum_1^n \frac{1}{Z_i}$$

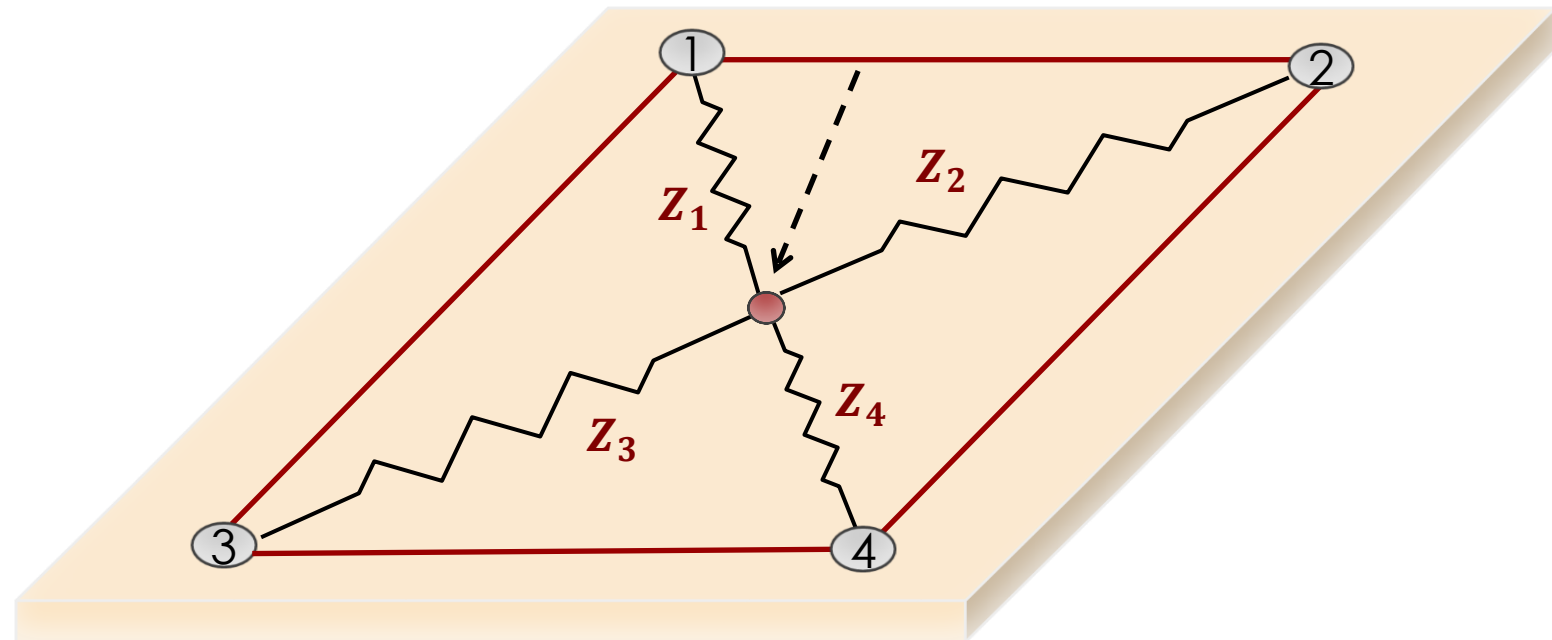



# Timing ASICs

**Timing ASICs are the most difficult part of this transition.**

Each replaces many racks of electronics, consume a fraction of the power, and vastly reduces the data transmission.

**The TDCPix for the NA62 GigaTracker (130 nm, 300x300  $\mu\text{m}^2$  pixel)** is considered the "**spiritual father**" of modern timing ASICs because it was the first to prove that you could integrate **sub-200 ps** timing directly into a high-rate pixel detector.

60x27 mm

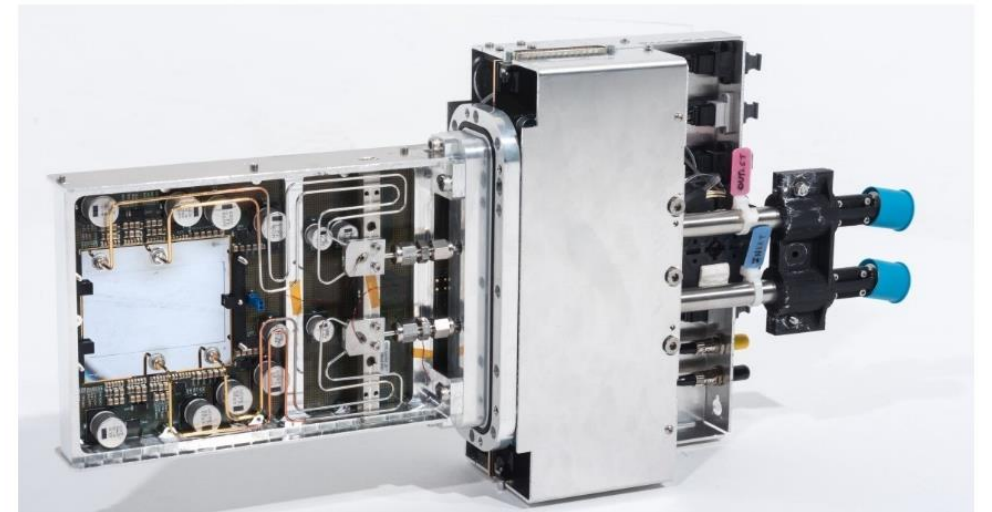
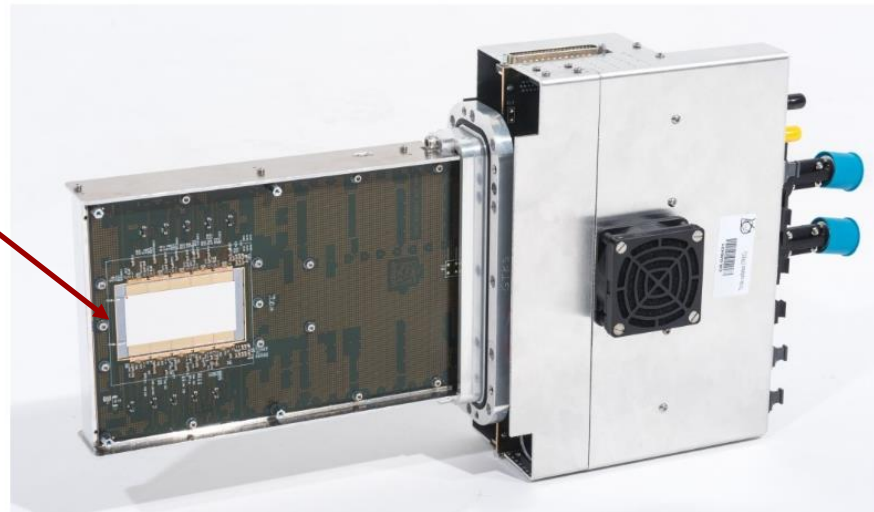

The NA62 GigaTracker



# ASICs for SiPM and LGAD

**ASICs for SiPM and for LGAD are conceptually very different** due to the differences in the signal and capacitance of the SiPM, LGAD.

Feature	SiPM ASICs	LGAD ASICs
<b>Input Challenge</b>	<b>High Capacitance &amp; Noise:</b> Large area SiPMs have huge capacitance, slowing down the signal.	<b>Low Signal &amp; High Speed:</b> Signals are tiny (<30 fC) and very fast (<1 ns rise time).
<b>Gain Management</b>	Handles <b>Gain <math>10^5</math> - <math>10^6</math></b> : Needs to manage large current pulses and wide dynamic range.	Handles <b>Gain 10 - 30</b> : Requires ultra-low-noise, high-bandwidth amplifiers to preserve the pulse shape.
<b>Key design issues</b>	Baseline restoration and dark-count filtering.	Low signal, low noise
<b>Quantities measured</b>	Time and amplitude	Time, amplitude for RSDs
<b>Examples</b>	Citiroc, Petiroc (Weeroc), TOFPET (PetSys).	ETROC (CMS), ALTIROC (ATLAS)



# Transition...

---

In past experiments, **timing had a specific use**, a stand-alone measurement. In these past examples, timing was a selection criterion.

**The advent of SiPM, LGADs, and timing ASICs changed what can be achieved.**

What is planned for future experiments is a **qualitatively different use of the timing information**, at several levels:

- **Granularity**, timing is part of the information to build the events, it is a coordinate
- **Resolution**, a performance leap from “nanosecond” to “picosecond”
- **Complexity**, millions of timing channels, with clock distribution at 5 ps level

# 4D tracking: granularity, resolution, complexity...

Without timing information, all hits are black... the reconstruction program has to try many different combinations.

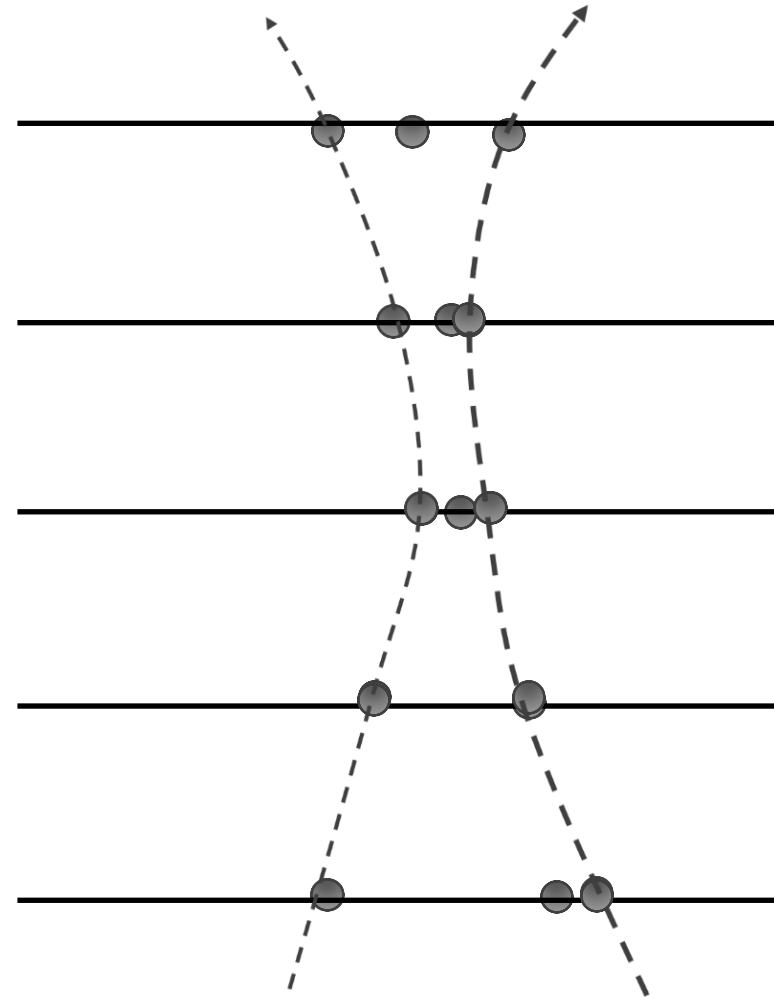

# 4D tracking: granularity, resolution, complexity...

Without timing information, all hits are black... the reconstruction program has to try many different combinations

## Granularity:

- Timing information is present at every hit.
- Strong simplification of the reconstruction code
- Allows handling many more particles

## Resolution:

- It is the key for this step, it has to be very good

## Complexity:

- Timing requires very complex ASICs, cooling, massive data transfer, clock distribution, ...

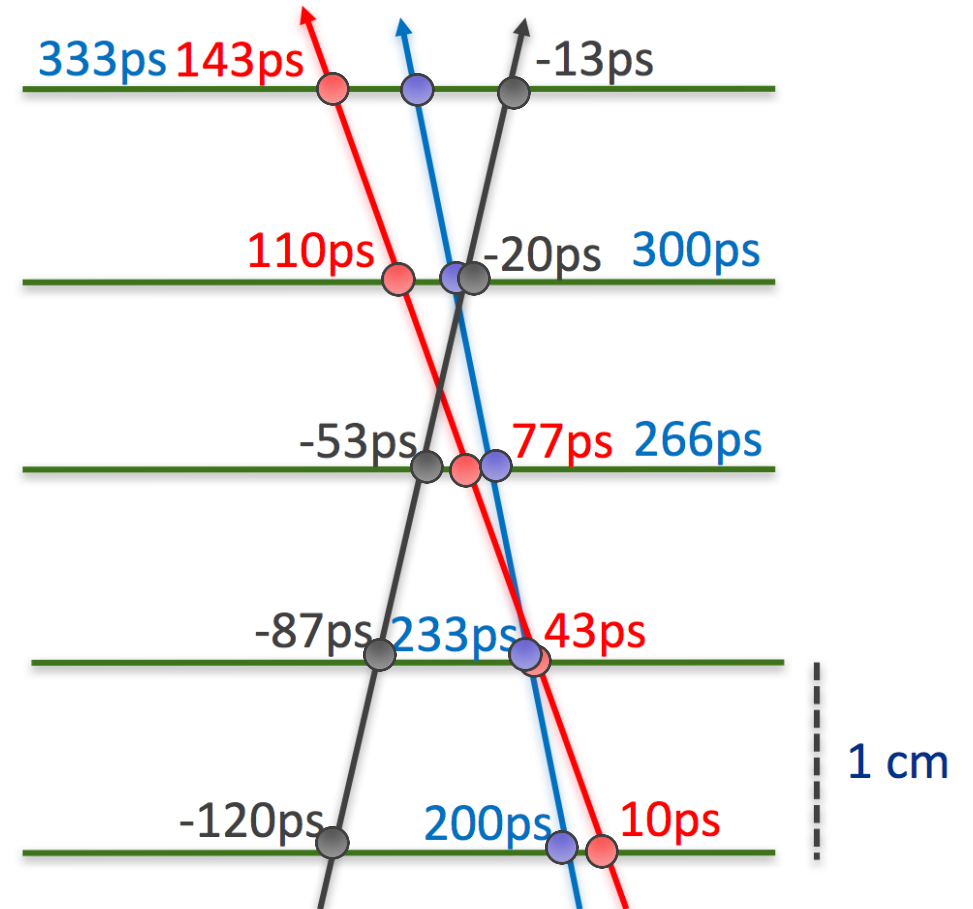

# Timing information in tracking systems

Timing can be available at different levels of the event reconstruction, in increasing order of complexity

**3+1 tracking (time, position):** Timing in the event reconstruction

- This is the easiest implementation, a timing layer

**4D tracking (time, position):** Timing at each point along the track

- Each layer provide position and time

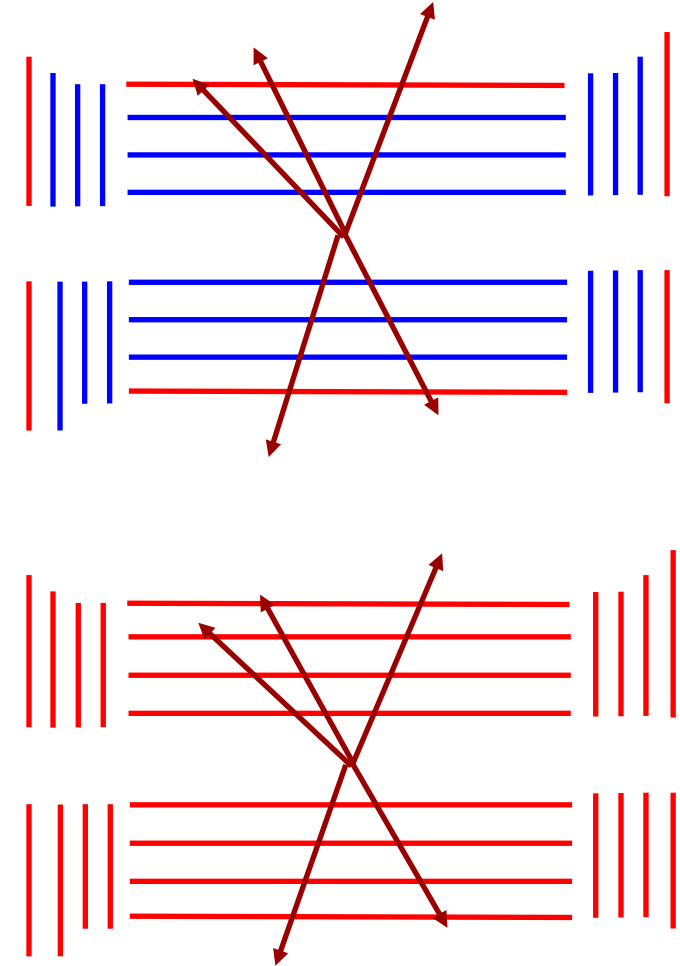



# The 4D tracking challenge

Key issues:  
**area and power**

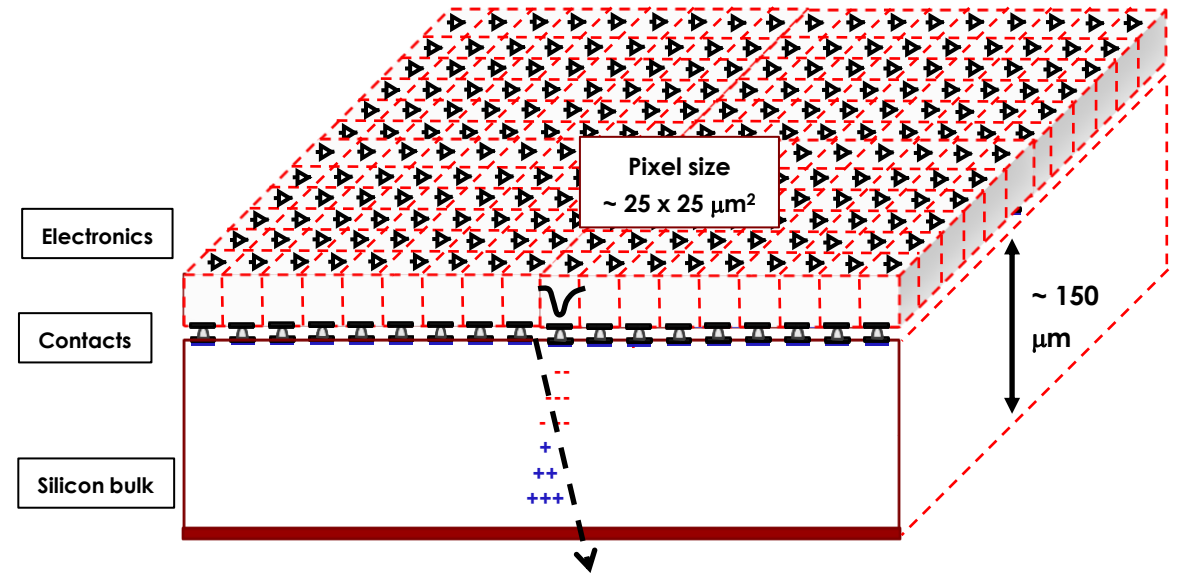
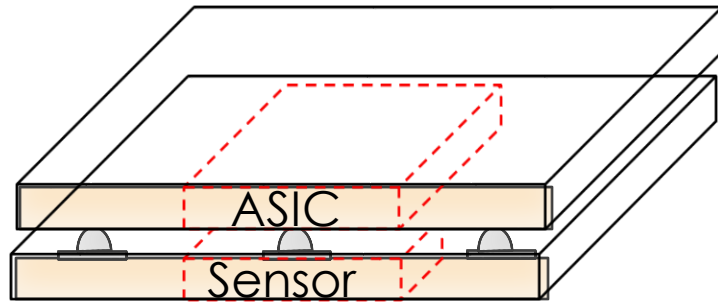

## Standard Tracker

### In standard pixels:

- The area of the pixel is equal to the area available to the electronics
- The power required to achieve high timing resolution would be prohibitive

### We need to:

- Reduce the number of pixels while maintaining the same spatial precision
- Or
- Design electronics that requires less power

# One sensor **DOES NOT** fit all

The optimization of a 4D silicon sensors depends on:

- **Spatial & Temporal Resolution**
- **Occupancy**
- **Material Budget**
- **Radiation Levels**
- **Power Consumption**

**These parameters are intertwined, so each application is different**

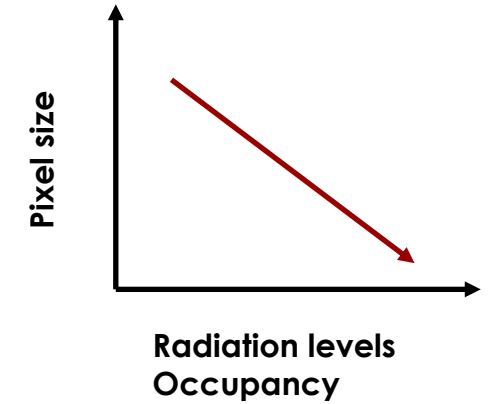
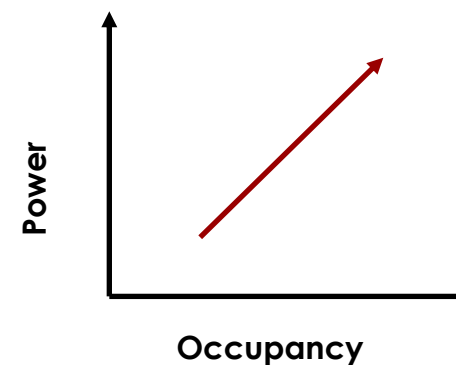
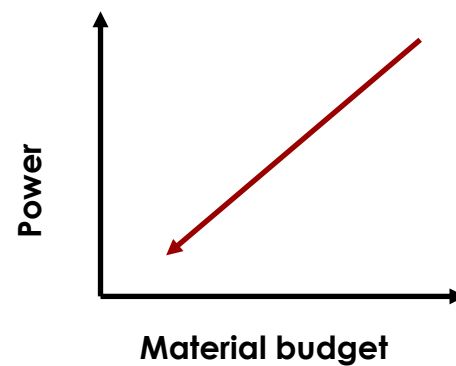
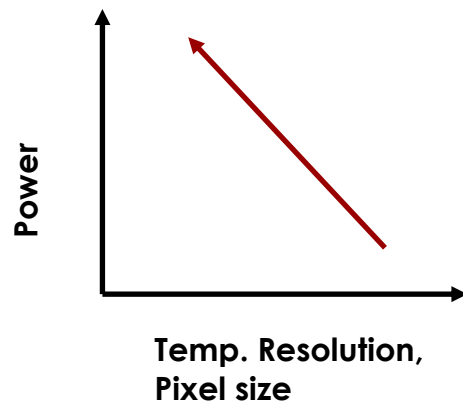

# 4D tracking: a very intense R&D

## Sensors for 4D tracking

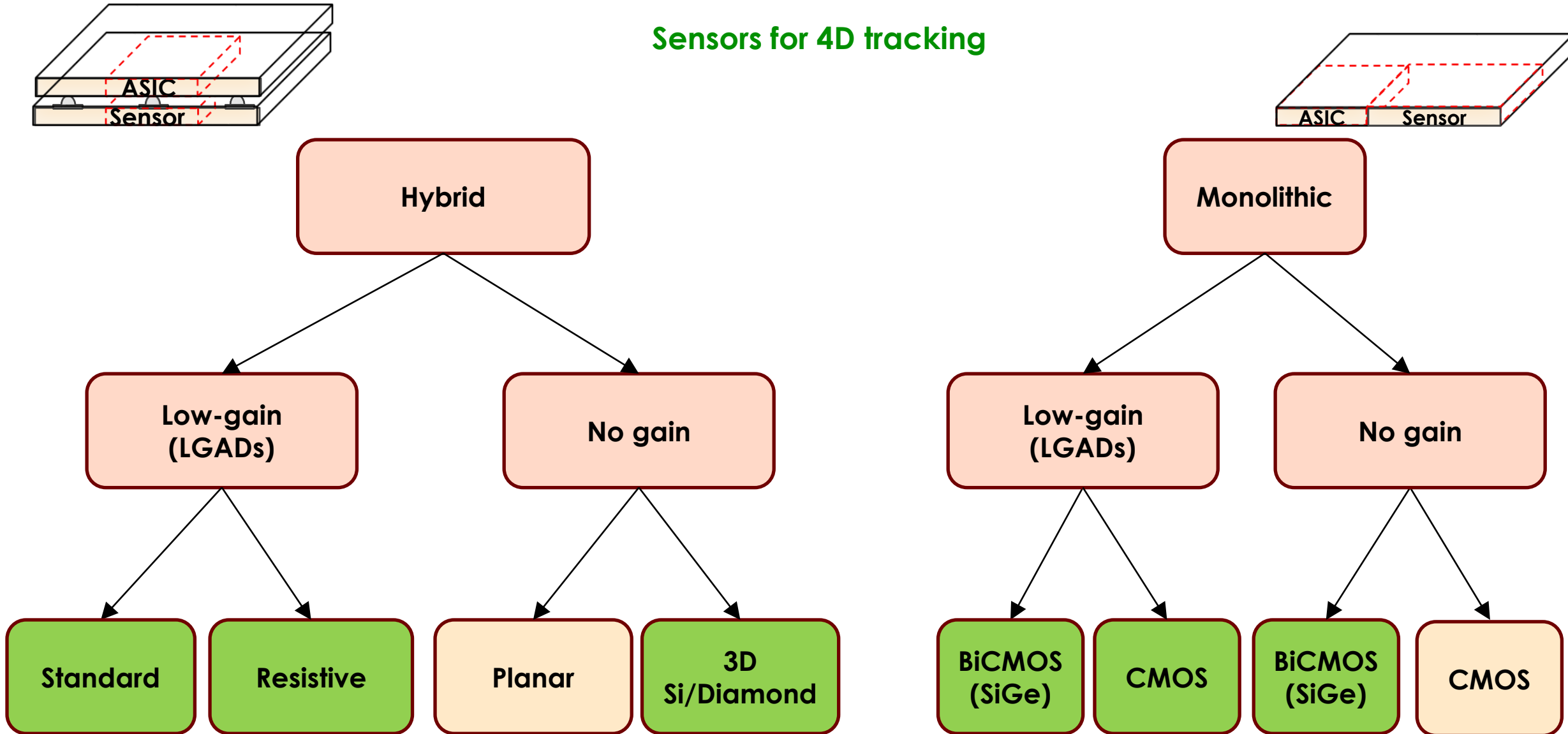

# New tools, new experiments

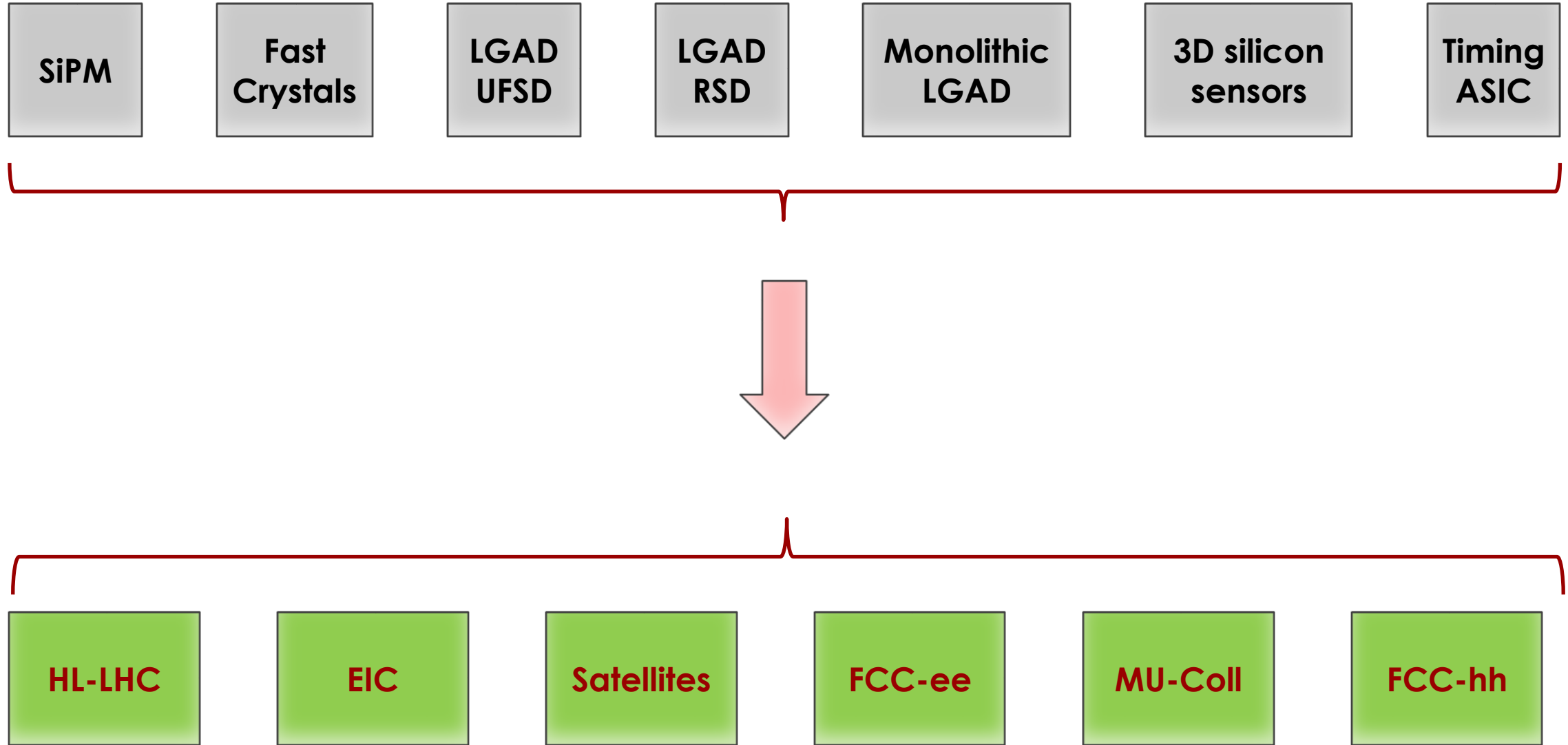



# The path to track-timing: CMS & ATLAS timing layers

CMS and ATLAS wanted to have track - timing information for pile-up rejection (3+1).

The problem: the decision was taken AFTER the respective detector optimization for HL-LHC

After long discussions, CMS provided:

- 4.5 cm (radially)** for the barrel timing layer,
- 9.9 cm (longitudinally)** for the endcap timing layer.

Technological solutions:

- **Barrel:** LYSO:Ce scintillators + SiPMs:  $\sim 38 \text{ m}^2$ ,  $\sim 350\text{k}$  channels
- **Endcap:** UFSD (LGADs):  $\sim 14 \text{ m}^2$ ,  $\sim 8.5 \text{ M}$  channels

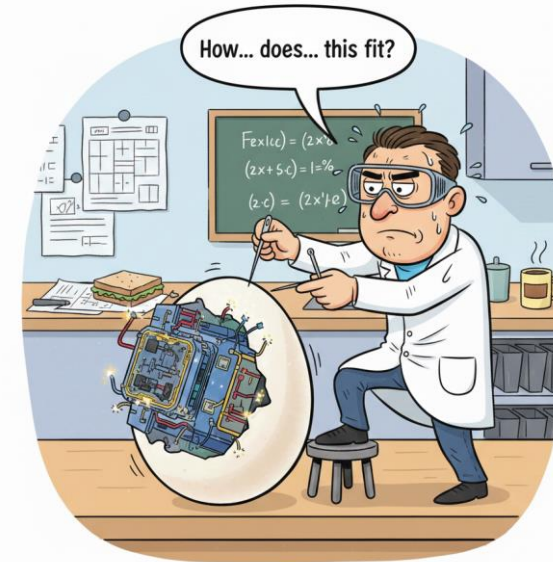



# The path to track-timing: CMS & ATLAS timing layers

## CMS MTD (MIP Timing Detector):

- **Barrel:** LYSO:Ce scintillators + SiPMs: ~ 38 m<sup>2</sup>, ~ 350k channels
- **Endcap:** UFSD (LGADs): ~ 14 m<sup>2</sup>, ~ 8.5 M channels
- Pixels 1.3 x 1.3 mm<sup>2</sup>
- **ETROC ASIC**, 65 nm

## ATLAS HGTD (High Granularity Timing Detector):

- **Endcap:** UFSD (LGADs): ~ 6.4 m<sup>2</sup>, ~ 3.5 M channels
- Pixels 1.3 x 1.3 mm<sup>2</sup>
- **ALTIROC ASIC**, 130 nm

In the allowed space, we need to fit evaporated CO<sub>2</sub> cooling....

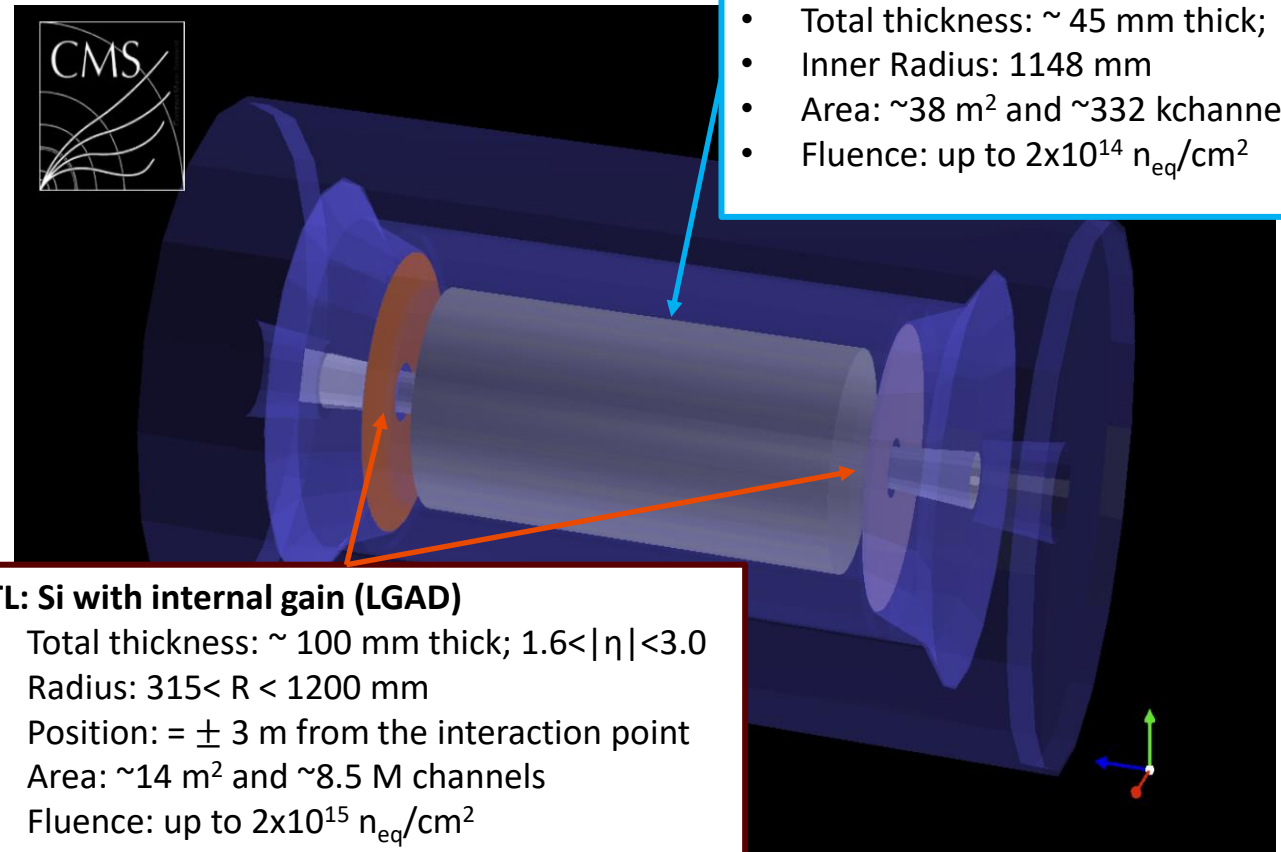



# The path to track-timing: RSD sensors

High spatial precision come at a cost: small pixels

**If you add timing, small pixels come at a cost: lots of power.**

Resistive silicon detectors allow to have large pixels (low power) and excellent spatial resolution (using charge sharing)

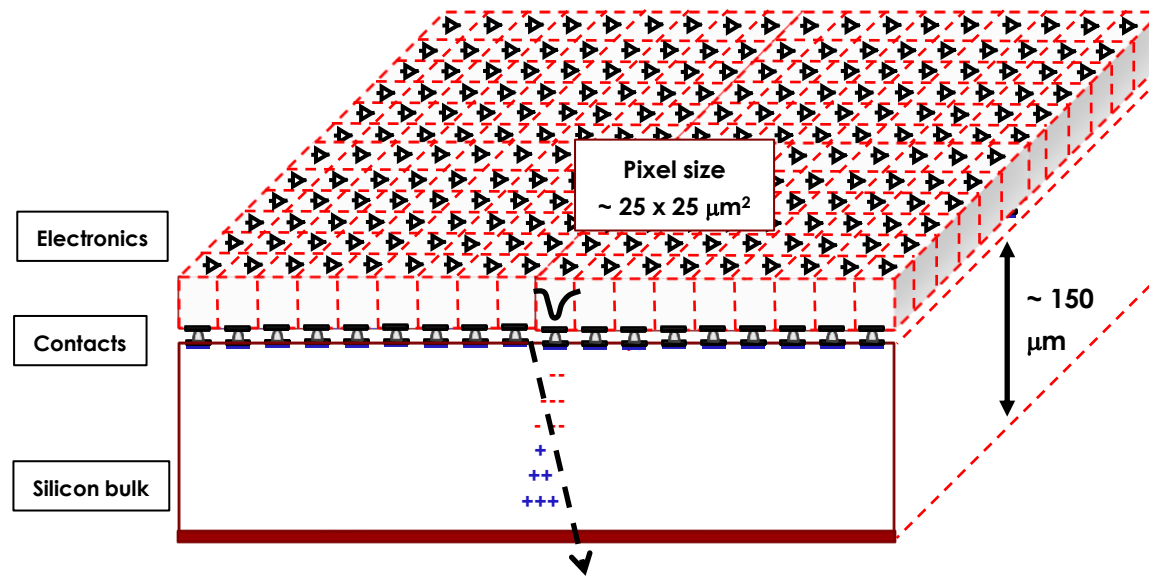

**Standard Tracker**

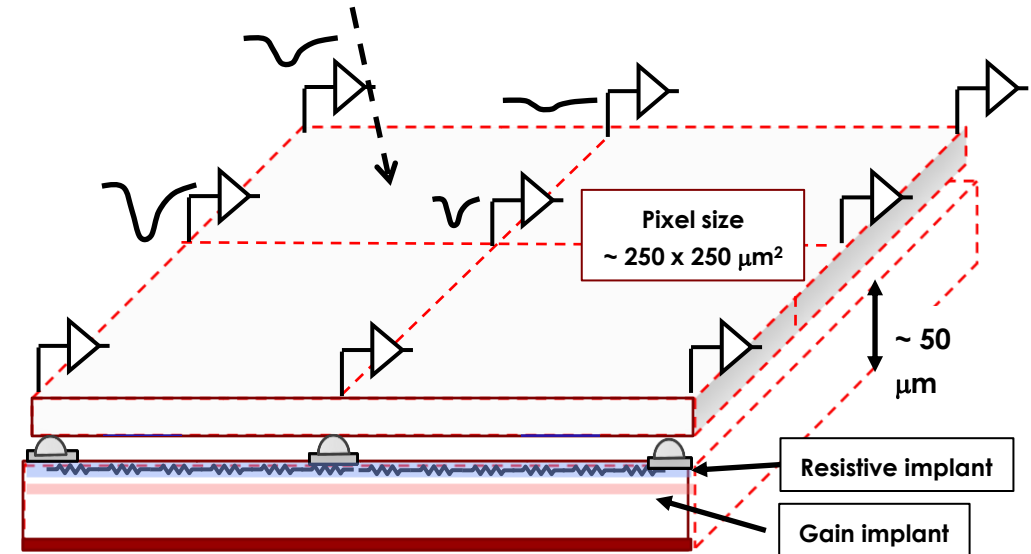

**4D-RSD based tracker**



# The path to track-timing: R&D to construction

## First use of RSD (AC-LGAD) in experiments:

large pixels/strips, excellent spatial and temporal resolutions

### PIONEER (PSI)

- Technology: AC-LGAD stack in the Active TARget (ATAR).
- Function: Decay Chain Topology. It uses timing ( $<100$  ps) to separate the stopping  $\pi^+$  from its decay products ( $\mu^+$ ,  $e^+$ ) in the same spatial volume.
- FAST ASIC

### EIC (ePIC Experiment)

- Technology: AC-LGADs for the Time-of-Flight (TOF) system.
- Function: Particle Identification (PID). The EIC requires  $\pi/K/p$  separation at low momenta.
  - Forward TOF: Pixels for high-rate 4D tracking.
  - Pixels  $0.5 \times 0.5$  mm<sup>2</sup>
  - Target: 25-35 ps resolution.
  - EICROC ASIC



# The path to track-timing: High fluence 4D

**In their upgrade for LS4 (~ 2034), LHCb plans to install the first 4D tracker:**

- Very high radiation level,  $\sim 6 \text{ E16 n/cm}^2$
- Very high particle occupancy
- Very high power density
- Very small area ( $\sim 0.15 \text{ m}^2$ )
- Tracks go through 7-10 layers, each with timing!

## **Technology:**

- 3D Trench Silicon (Inner) and LGAD/Planar (Outer)
- $55 \times 55 \text{ } \mu\text{m}^2$
- PICOPIX ASIC

## **Function:**

- Full 4D Vertexing.

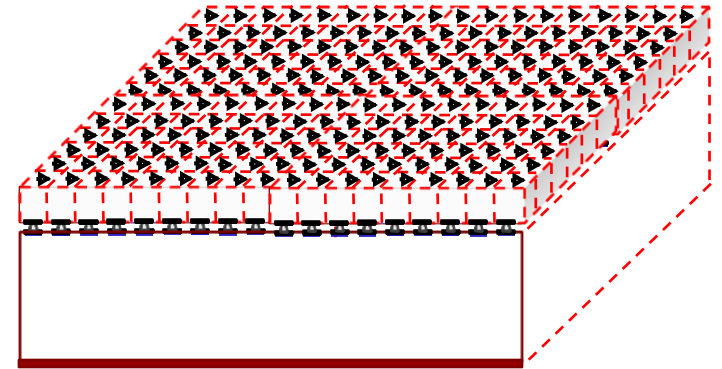



# The path to track-timing: monolithic 4D

## ALICE 3 looks at the other extreme: "Nearly Massless" Tracker

- Low radiation,  $\sim 0.5-1 \text{ E14 n/cm}^2$
- Very low material budget
- Low power ( $< 40 \text{ mW/cm}^2$ )
- Large area ( $\sim 45 \text{ m}^2$ )
- **Technology:**
  - CMOS-LGADs (ARCADIA, MADPix)
  - Monolithic sensors, bent geometry
- **Function:**
  - Pion/Kaon separation

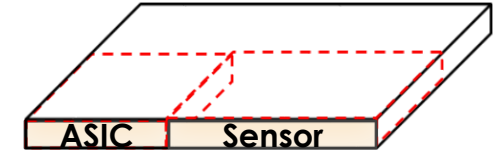



# The path to track-timing: far future

## **FCC-ee: The "Precision" Frontier**

- Foreseen Timing:  $\sim 10$  ps is the target for the TOF system (using LGADs or TORCH-like detectors).
- Physics Case: Providing 3 sigma K/pi separation up to  $\sim 5$  GeV.
  - Without this, the flavour physics program would be statistically limited by misidentification.

## **Muon Collider: The "Survival" Frontier**

- Foreseen Timing: 20 - 30 ps in the Vertex detector.
- Physics Case: muons create a "storm" of Beam-Induced Background (BIB).
  - Without timing, the detector occupancy would be nearly 100%: a very narrow time window ( $\sim 150$  ps) can "gate out" the BIB rejecting 99% of the hits in the tracker.

## **FCC-hh: The "Intensity" Frontier**

- Foreseen Timing:  $< 10$  ps.
- Physics Case: Pile-up  $\sim 1000$ , at this density, spatial tracking alone cannot resolve the primary vertices. You need a "Time-Z" map



# The path to track-timing: summary table

Experiment	Target $\sigma_t$ (track)	Technology	Primary Function
<b>CMS</b> (MTD)	30 – 40 ps	LGAD / Scint.	Pile-up Rejection
<b>ATLAS</b> (HGTD)	30 – 40 ps	LGAD	Pile-up Rejection
<b>PIONEER</b> (ATAR)	~ 20 ps	AC-LGAD (RSD)	Decay Topology (5D)
<b>EIC (ePIC)</b> (TOF)	~ 20 – 30 ps	AC-LGAD	Particle ID
<b>LHCb Up. II</b> (VELO)	~20 ps	3D Trench	4D Vertexing
<b>ALICE 3</b> (TOF)	~20 ps	Monolithic LGAD	Hadron ID

## Far future:

Collider	Target $\sigma_t$ (track)	Technology	Primary Function
<b>FCC-ee</b> (~2045)	10 - 30 ps	RSD / Monolithic	Particle ID (PID)
<b>Muon Col.</b> (~2050)	20 - 30 ps	3D Trench / LGAD	BIB Rejection
<b>FCC-hh</b> (~2065)	< 10 ps	3D Trench / SiC / 28nm	Pile-up (1000 PU)



# Timing calorimeter: CMS HGCAL

**Imaging calorimeter**, HGCAL uses timing to reject "halo" hits and out-of-time pile-up, effectively "cleaning" the shower prior to energy reconstruction.

**Technology:** Silicon and Scintillator-SiPM tiles.

Component	Specification	Details
Silicon Surface Area	~600–620 m <sup>2</sup>	Uses hexagonal 8-inch wafers 120/200/300 μm thickness.
Scintillator Area	~370 m <sup>2</sup>	Plastic scintillator tiles read out by on-tile SiPMs.
SiPM Total Count	~240,000	9 mm <sup>2</sup> SiPMs mounted directly on scintillator tiles.
Readout Channels	~6,000,000	6M silicon pad channels + ~240k-280k scintillator channels.

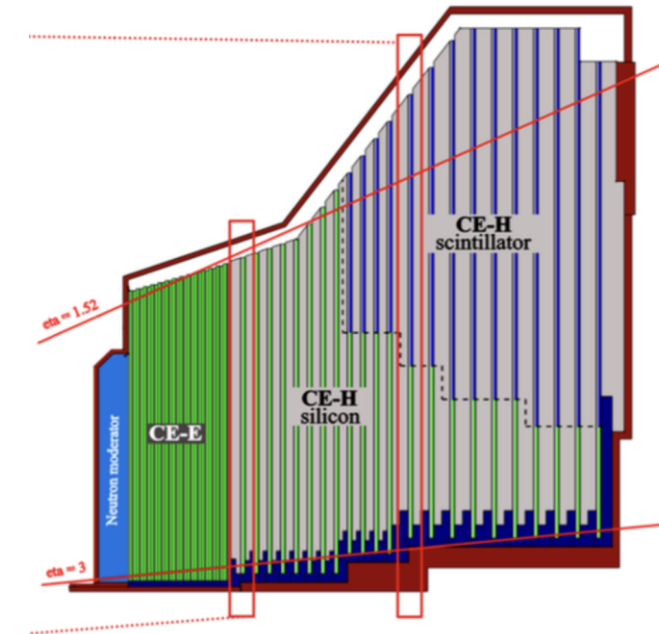



# Timing – calorimeter: CMS HGCAL

**Goal:** 30 ps timing for clusters above 5 GeV.

- **Role:** Essential for "cleaning" the shower. It allows for the rejection of out-of-time pile-up and the association of showers with the correct primary vertex, which is crucial for Jet Energy Resolution in the 200 pile-up environment of the HL-LHC.

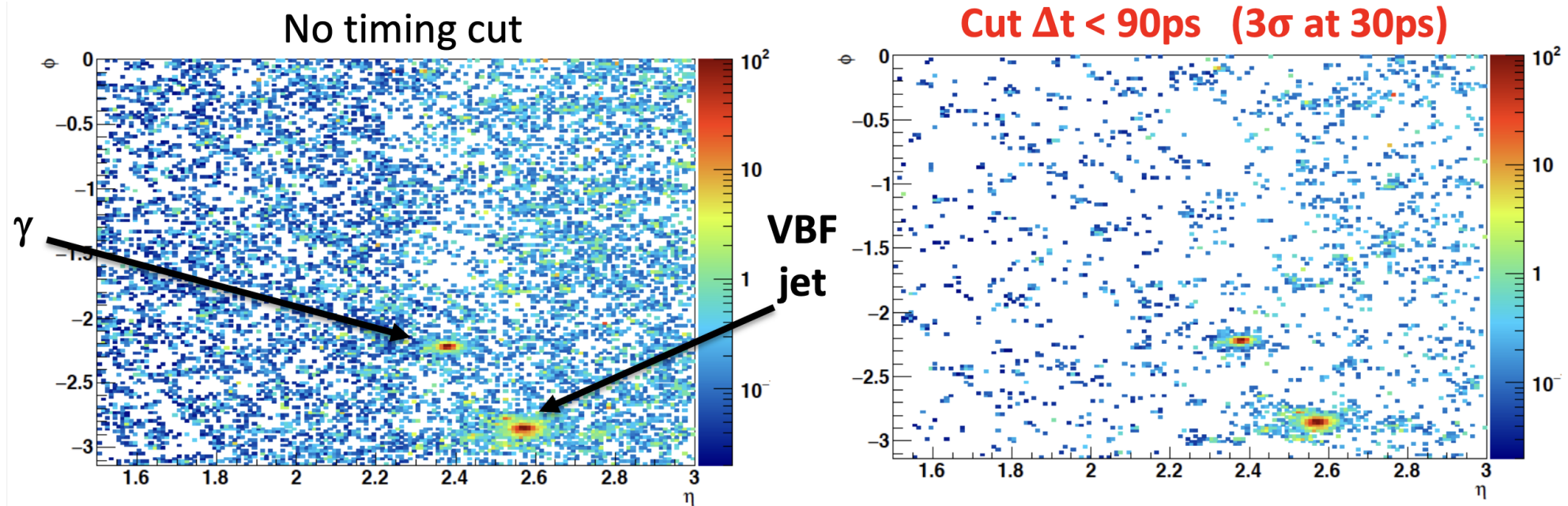



# Timing – calorimeter: far future

---

## **Muon Collider (The BIB Filter):**

- **Goal:** 80 ps (or better) per cell.
- **Role:** Timing is the primary tool to suppress **Beam-Induced Background (BIB)**. Since BIB particles are asynchronous and often arrive earlier or later than the physics products, a narrow timing gate (e.g.,  $\pm 150$  ps) "erases" the majority of the background hits, making calorimetry possible.

## **FCC-ee (Dual-Readout / IDEA):**

- **Goal:** 100 ps per fiber.
- **Role:** Uses the time-of-arrival of the **Cherenkov component** vs. the **Scintillation component** to determine the longitudinal position of the shower center without physical segmentation.



# Gaseous and Cherenkov Systems: Future

## TORCH (LHCb Upgrade II):

- **Technology:** 1 cm thick quartz plates + MCP-PMTs.
- **Goal:** 15 ps per track (requires ~70 ps per single photon).
- **Role:** Reconstructs the time-of-flight over 9.5 meters to provide K/pi separation up to 10 GeV/c and p/K up to 15 GeV/c.

## PICOSEC Micromegas:

- **Technology:** Gaseous detector with a Cherenkov radiator and photocathode.
- **Goal:** < 25 ps for MIPs.
- **Role:** A potential "timing wall" for large-area coverage where silicon would be too expensive. It effectively acts as a gaseous TOF layer.

## 4D-RICH:

- **Technology:** Gas/Aerogel
- **Goal:** < 100 ps per photon.
- **Role:** Using timing to reduce the "combinatorial background" in Cherenkov ring reconstruction. By knowing exactly when each photon arrived, you can filter out photons that don't belong to the track's time window.



# Timing in the sky: Satellites

---

**For satellites, the primary drivers are:**

- **Particle Identification (PID),**
- **Isotope separation,**
- **Directionality**

**Space is the ultimate "Low Power" boundary:** strict power budget (e.g.,  $<20 \text{ mW/cm}^2$ ).

**TOF:**

Particle identification and isotope separation (like  $^3\text{He}$  vs  $^4\text{He}$ )

**Directionality and "Self-Veto"**

**4D Solution:** High-precision timing allows a single silicon layer to determine the **direction of travel** (upwards vs. downwards) based on the delay between the signal at the top and bottom.



# Satellites

Mission / Project	Technology	Target $\sigma t$	Primary Function
<b>AMS-02 (Current)</b>	Scintillator	~160 ps	Up/Down Veto & Trigger
<b>HERD (Planned)</b>	LGAD / Silicon	30–50 ps	Isotope Separation
<b>PAN (Deep Space)</b>	Timepix-based	~1 ns	Solar Particle Monitoring
<b>ALADInO</b>	UFSD / Si-Strips	< 100 ps	Antimatter Search (ToF)



# Timing ASICs

---

**I like to develop silicon sensors because ASICs are too difficult...**



# The "Large-Scale Industrial" ASICs (HL-LHC)

These are the "mature" chips currently in production or late-stage testing.

**ETROC (CMS):** 65 nm CMOS, **ALTIROC (ATLAS),** 130 nm CMOS.

- **Focus:** Designed for the CMS/ATLAS LGAD timing layer.
- **Architecture:** Time-over-Threshold (ToT) for time-walk correction.
- **Performance:** Aiming for ~25 ps electronics jitter

**TOFHIR2 (CMS):** 130 nm CMOS

- **Focus:** Designed for the CMS SiPM+Crystal timing layer.
- **Architecture:** Dark count cancellation, ToA, Charge
- **Performance:** Aiming for 30 (new) – 60 (end of life) ps electronics jitter



# The "High-Resolution / High-Granularity" ASICs (EIC & Precision)

## The "High-Resolution / High-Granularity" ASICs (EIC & Precision)

These chips are optimized for **AC-LGAD (RSD)** sensors, where signal sharing requires measuring the pulse amplitude precisely.

**EICROC** (130 nm)/ **FCFD**: 65 nm CMOS (CEA-Irfu / Fermilab).

- **Focus:** Specifically for the EIC TOF layers.
- **Innovation:** These must measure both **Time-of-Arrival (ToA)** and **Charge (Amplitude)**.



# The "Next-Gen Frontier" ASICs (28 nm node)

**TIMESPOT1 (INFN):** The first 28 nm demonstrator.

- **The Achievement:** It proved you can fit a **TDC in every pixel** (55x55  $\mu\text{m}$ ) with a resolution of **7 ps**.
- **Constraint:** The power density is very high ( $\sim 1.5\text{-}2 \text{ W/cm}^2$ ), which is the primary challenge for future 4D trackers.

**PICOPIX (CERN/Timepix family):** The "production" 28 nm chip.

- **Strategy:** It uses the **Analog Island** concept (shared resources) to bring the power down while keeping the timing at the  $\sim 20 \text{ ps}$  level. It is the baseline for the LHCb VELO Upgrade II.



# The "Alternative" Paths

---

**ASOC / SAMPIC:** These are **Waveform Digitizers** rather than simple TDCs.

- **Concept:** They "sample" the entire pulse (like a GHz oscilloscope on a chip).
- **Pros:** Best possible timing (sub-10 ps is possible) because you can perform offline analysis of the full shape.
- **Cons:** Massive data volume and high power. Suitable for detectors with fewer channels (like MCP-PMTs or small SiPM arrays).



# ASIC for 4D tracking

ASIC	Process	Pixel Size	Power / Channel	Power Density	Timing Resolution
<b>ALTIROC</b>	130 nm	1.3x1.3 mm <sup>2</sup>	4 - 5 mW	1.5 W/cm <sup>2</sup>	~25 ps
<b>ETROC</b>	65 nm	1.3x1.3 mm <sup>2</sup>	<3 mW	1.3 W/cm <sup>2</sup>	~20 ps
<b>EICROC</b>	130 nm	0.5x0.5 mm <sup>2</sup>	1 - 2 mW	0.4-0.8 W/cm <sup>2</sup>	~25 ps
<b>PICOPIX</b>	28 nm	55x55 μm <sup>2</sup>	40 - 60 μW	~ 1.5 W/cm <sup>2</sup>	~15 ps
<b>TIMESPOT</b>	28 nm	55x55 μm <sup>2</sup>	30 - 40 μW	~ 2 W/cm <sup>2</sup>	~7 ps

# What's next

---

“It is not possible to build the future on the basis of the present”

**Homi J. Bhabha,**

International Atomic Energy Agency (IAEA),

Vienna, September 1957



# Extra

---

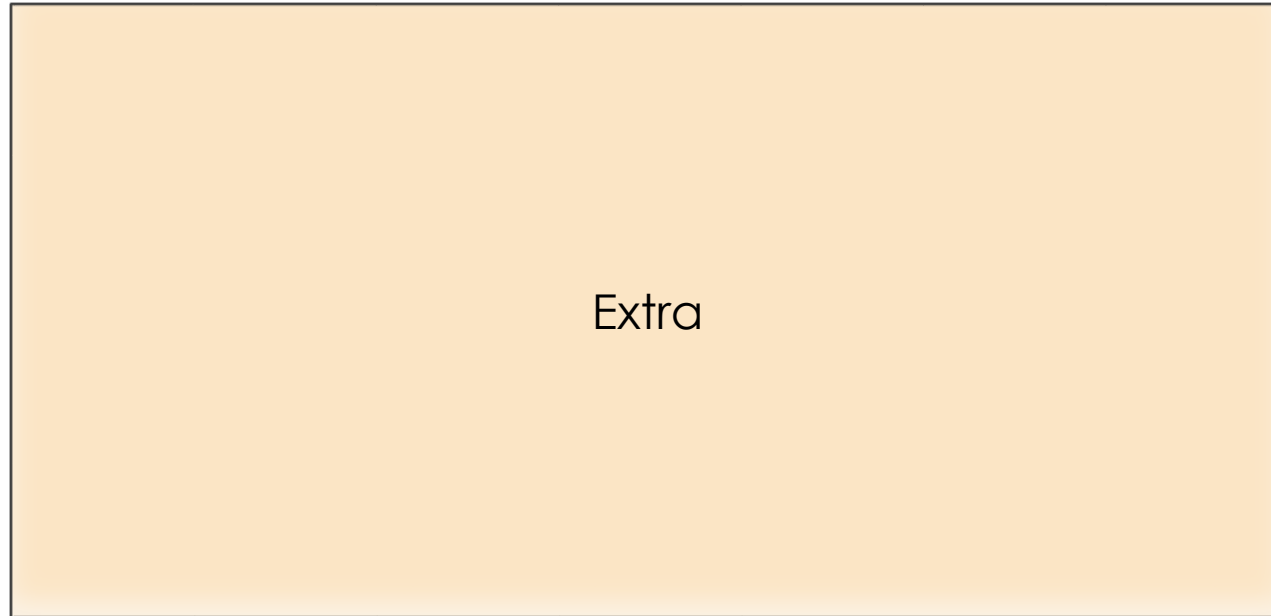



# Future challenges

---

- **Low power timing ASIC**
  - Well below  $1\text{W}/\text{cm}^2$
- **Increase LGAD radiation resistance to  $1\text{E}16\text{ n}/\text{cm}^2$** 
  - Compensated LGAD,
- **Picosecond clock distribution**
  - Need to reach 5 ps
- **Thermal management**
  - Low mass  $1\text{W}/\text{cm}^2$  cooling system



# Silicon-Based Technologies (The Tracking Standard)

## Standard LGAD (Low-Gain Avalanche Diode):

- **Mechanism:** Uses a thin p-type gain layer to create a moderate internal multiplication (gain  $\approx 10-30$ ).
- **Performance:**  $\sim 30$  ps resolution in large-area detectors (CMS/ATLAS).
- **Limit:** The "fill-factor" problem (dead areas between pixels) and radiation-induced gain loss.

## AC-LGAD / RSD (Resistive Silicon Detector):

- **Mechanism:** Signal is capacitively coupled to electrodes through a resistive layer, allowing for **signal sharing**.
- **Advantage:** Achieves 100% fill factor and micron-level spatial resolution with fewer, larger electrodes.
- **Use Case:** EIC (ePIC) and PIONEER experiments.

## 3D Trench Sensors:

- **Mechanism:** Decouples the drift distance from the sensor thickness by etching electrodes deep into the silicon bulk.
- **Performance:** Reaches the **intrinsic limit of silicon ( $\sim 10$  ps)**.
- **Advantage:** Extreme radiation hardness ( $> 10^{16} \text{ n}_{\text{eq}}/\text{cm}^2$ ). Best suited for high-radiation cores like the LHCb VELO.



# Scintillator & Photonic Technologies (The Large-Area Standard)

---

## **LYSO Crystals + SiPM (Silicon Photomultipliers):**

- **Mechanism:** Ionizing particles create light in a dense crystal (LYSO), which is captured by ultra-fast SiPMs.
- **Performance:** 30–40 ps at the system level.
- **Use Case:** CMS Barrel Timing Layer (BTL).

## **TORCH (Quartz Radiator + MCP-PMT):**

- **Mechanism:** Uses Cherenkov light propagation in a quartz plate, read out by Microchannel Plate PMTs.
- **Performance:** ~ 15 ps per track.
- **Use Case:** High-precision Particle ID (LHCb Upgrade II).



# Gaseous Timing Technologies (The High-Rate/Cost Frontier)

## **PICOSEC Micromegas:**

- **Mechanism:** A Cherenkov radiator and photocathode convert a particle into electrons, which are amplified in a two-stage Micromegas gap.
- **Performance:** < 25 ps.
- **Advantage:** Highly radiation-hard and potentially cheaper for massive forward "timing walls."

## **MRPC (Multi-gap Resistive Plate Chamber):**

- **Mechanism:** High-pressure gas gaps with high electric fields to create ultra-fast avalanches.
- **Performance:** 50–80 ps.
- **Use Case:** Large-area TOF (ALICE, CBM).



# Summary of non-tracking projects

---



Non tracking



# 5D Calorimetry: The "PicoCal" and HGCAL Era

**LHCb PicoCal:** A multi-technology proposal for Upgrade II. It aims for  $\sim 20$  ps resolution using:

- **SpaCal (Spaghetti Calorimeter):** Tungsten/Lead absorber with scintillating fibers.
- **Shashlik:** Scintillator/lead stacks with Wavelength Shifting (WLS) fibers.
- **The Vision:** Using timing to separate overlapping electromagnetic showers in the high-occupancy central region.

**CMS HGCAL (High Granularity Calorimeter):**

- Uses **SiPM-on-scintillator** tiles in the hadronic section.
- Targeting **30 ps** timing for clusters  $> 5$  GeV to reject pile-up "halo" hits.

**Crilin (Crystal Calorimeter):** Developed for the **Muon Collider**.

- Uses **PbF<sub>2</sub>** or ultra-fast **PbWO<sub>4</sub>** crystals.
- Achieved  $< 25$  ps in test beams for electrons  $> 3$  GeV.
- This is critical to timing-out the **Beam Induced Background (BIB)**.



# Gaseous Timing: The PICOSEC Micromegas

the **PICOSEC Micromegas** is a unique "hybrid" gaseous-optical detector.

- **Physics:** A charged particle hits a **Cherenkov radiator** (MgF<sub>2</sub>) followed by a **photocathode** (CsI). The resulting photoelectrons are amplified in a Micromegas gap.
- **Performance:** Consistently delivering **< 25 ps** for MIPs.
- **The "Vision" Value:** It provides a radiation-hard, large-area alternative to silicon where the cost of UFSD would be prohibitive (e.g., forward sampling calorimeters or dedicated TOF walls).



# RICH Evolution: The 4D-Photon Project

Pushing the **RICH (Ring Imaging Cherenkov)** into the 4D domain.

- **Technology:** Coupling a **Microchannel Plate (MCP-PMT)** directly to a **Timepix4** or **PICOPIX** anode.
- **Performance:** Reaching **~30 ps** for single photons.
- **Impact:** By timing every photon in the Cherenkov ring, you can drastically reduce background and improve velocity resolution, even in high-luminosity environments like **ALICE 3** or **LHCb Upgrade II**.



# Dual-Readout Calorimetry (IDEA / FCC-ee)

This is a massive topic for the **FCC-ee** community (the **HiDRa** and **ASPIDES** projects).

- **Mechanism:** Simultaneously measuring **Scintillation** light (total energy) and **Cherenkov** light (EM component) in fibers.
- **Timing Role:** Using the time-of-arrival of the Cherenkov signal to reconstruct the **longitudinal position** of the shower without physical segmentation.
- **Electronics:** Read out by **SiPMs** and ASICs like **Citiroc** or specialized TDCs targeting **< 100 ps** per fiber.



# Evolution

---

Feature	Past/Present	Next 10 Years
<b>Role of Timing</b>	<b>Asynchronous / Veto:</b> Timing cleans the data (rejection).	<b>Synchronous / Coordinate:</b> Timing builds the data (reconstruction).
<b>Precision</b>	Nanosecond to 100 ps	<b>Picosecond:</b> 10 - 30 ps target
<b>Location</b>	<b>External:</b> Standalone TOF walls or calorimeters	<b>Internal:</b> Integrated into the <b>tracking layers and imaging calorimeters</b>
<b>Primary Goal</b>	Background Suppression	<b>Pile-up Mitigation / 5D Particle Flow</b>



# Historical baseline (details) - I

## 1. Particle Identification (PID) via Time-of-Flight

Historically, this was the most common use of timing. By measuring the velocity ( $\beta$ ) and momentum ( $p$ ), the mass of the particle is determined.

### •CDF II (Tevatron):

- **Technology:** Scintillator bars + Fine-mesh Photomultipliers (PMTs) capable of operating in a 1.4 T field.
- **Function:** Specifically added for **Charged Kaon identification** to improve B-flavor tagging.
- **Performance:**  $\sim 100$  ps resolution. This was the "gold standard" for scintillator-based TOF in high-field environments before the SiPM era.

### •ALICE (LHC):

- **Technology:** Multigap Resistive Plate Chambers (MRPC).
- **Function:** Large-area TOF for hadron identification at low-to-intermediate momenta.
- **Performance:**  $\sim 60$  ps resolution. It proved that gaseous detectors could reach the sub-100 ps regime over square meters of area.

### •B-Factories (Belle / BaBar):

- **Technology:** Quartz radiators using Cherenkov light (TOP Counter in Belle II, DIRC in BaBar).
- **Function:** Disentangling pions and kaons for CP violation studies.
- **Impact:** These were the precursors to modern fast-timing RICH systems.



# Historical baseline (details) - II

## 2. Background & Pile-up Rejection

In these experiments, timing isn't for identifying the particle species, but for identifying the **event** itself.

### NA48 (CERN):

**Technology:** Liquid Krypton (LKr) Calorimeter + Scintillating Hodoscope.

**Function:** Used to measure the relative time between K<sub>L</sub> and K<sub>S</sub> decays to an accuracy better than **200 ps**. This was critical for **pile-up rejection** and defining the fiducial volume for the epsilon'/epsilon measurement.

**Legacy:** This is exactly the "Pile-up Rejection" role that your UFSDs are now performing for the HL-LHC, but on a much smaller and slower scale.

## 3. Directionality & Physics Triggering

Using timing to define the "vector" of physics.

### AMS-02 (International Space Station):

**Technology:** Scintillator paddles.

**Function:** Discriminating between upward-going and downward-going particles to reject "albedo" cosmic rays.

**Performance:** ~160 ps. It also provides the primary trigger for the entire magnetic spectrometer.