

Quanastra Pvt Ltd

Enabling the Next Generation of Photonic and Quantum Chips

January 2026

Telephone

+91 9205771590

Address

M-60 Nawada, Uttam
Nagar, Delhi - 110059

Website

www.quanastra.com

Email

vidur.raj@quanastra.com



About Quanastra

Quanastra develops and manufactures quantum technologies that enable quantum applications and advanced future technologies

Our **Advanced Single Photon Detectors** can measure the **smallest amount of light** possible, crucial for a range of **quantum applications**, particularly quantum communications.

These detectors also have applications in **bioimaging**, **spectroscopy**, **telecommunications**, and **astronomy**, where high-precision measurements of low-light or single-photon-level signals are required.

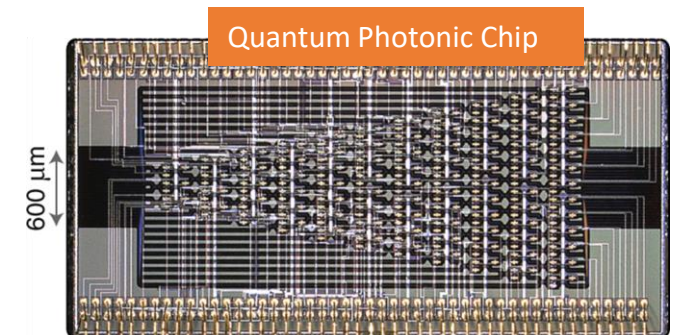
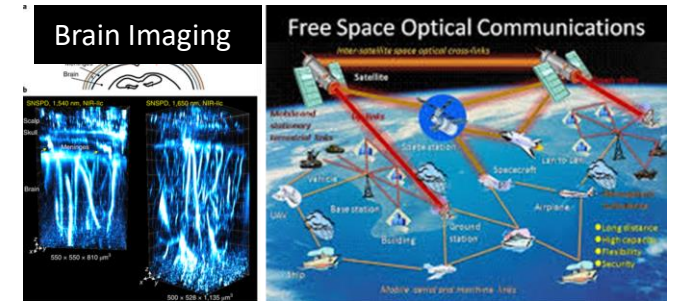

People Leading the Quantum Revolution

Quanastra is led by a team of passionate scientists and engineers with a proven track record of success. We have the expertise, the drive, and the vision to revolutionize this industry



Dr. Vidur Raj
(Ramanujan Fellow)

FOUNDER



Dr. Devendra Namburi

Tech LEAD, BULK
CONDUCTIVITY (Yet to Join)



Dr. Ajay K Sao

Tech Lead, UHV Design



Dineshwara Manideepu P

FINANCE



Ritika Gupta (M.Sc)

Accountancy/Market Data
Analysis

Scientific Mentors:



Prof. Venugopal Achanta
Director CSIR-NPL



Prof. R P Singh
Quantum Technologies - PRL



Prof. Karthik Raman
TIFR, Hyderabad

TOTAL NUMBER OF FULL TIME EMPLOYEES:

- 3X PHDs
- 1X Accountant cum data analyst
- 1X Mechanical Engineer
- 1X Electrical Engineer

FEE-BASED PROFESSIONALS:

5X (including CA, CS, IP Lawyer, Finance MBA)

INTERNS: Upto 10X (Yet to Hire)

Quanastra's cutting edge solutions

We offer high-performance single-photon detection systems in **table-top, rack-mounted, and fully customizable configurations** to meet diverse research needs

Our products empower scientists to explore the universe at the quantum level, from deep-UV to mid-infrared, with the precision and flexibility they need

Table - Top fully integrated

Compact and user-friendly, ideal for laboratory settings, high performance in a convenient package.



Rack Mounted fully integrated

Scalable and modular design, suitable for demanding research environments, robust and reliable performance

Fully Customizable

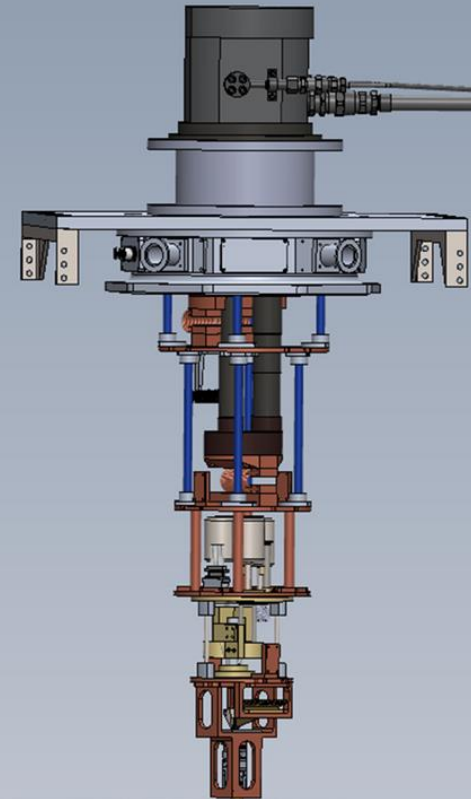

Currently at Quanastra

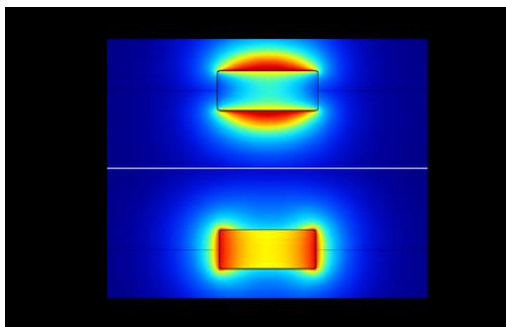

Broadband Waveguide Coupler

We are developing on-chip SNSPDs with on-chip HBT capability with future expansion into Quantum Tranceivers

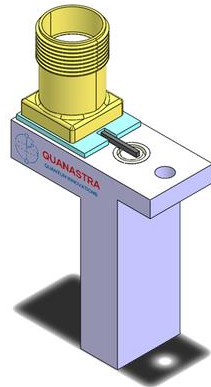

Patented Fiber Alignment Technology

We have been able to develop a tech that for fiber alignment with chip



Customized SNSPD Systems

We can customize the cryostat as per your requirement.



Free Space Quantum Comm Channel

We are in process of putting together a free-space roof-to-roof Q-comm setup.

Superconducting Nanowire Single-Photon Detector

- 98 % QE at 1550 nm with optical cavity [1]
- Spectral sensitivity from UV up to 10 μm [2]
- Sub-3 ps timing jitter [3]
- Turn-key closed cycle cooling

Two challenges:

- High performance in mid IR
- Scale up to arrays

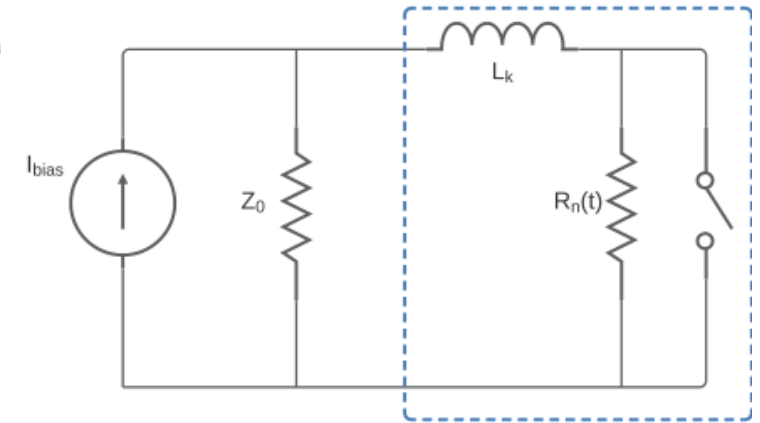
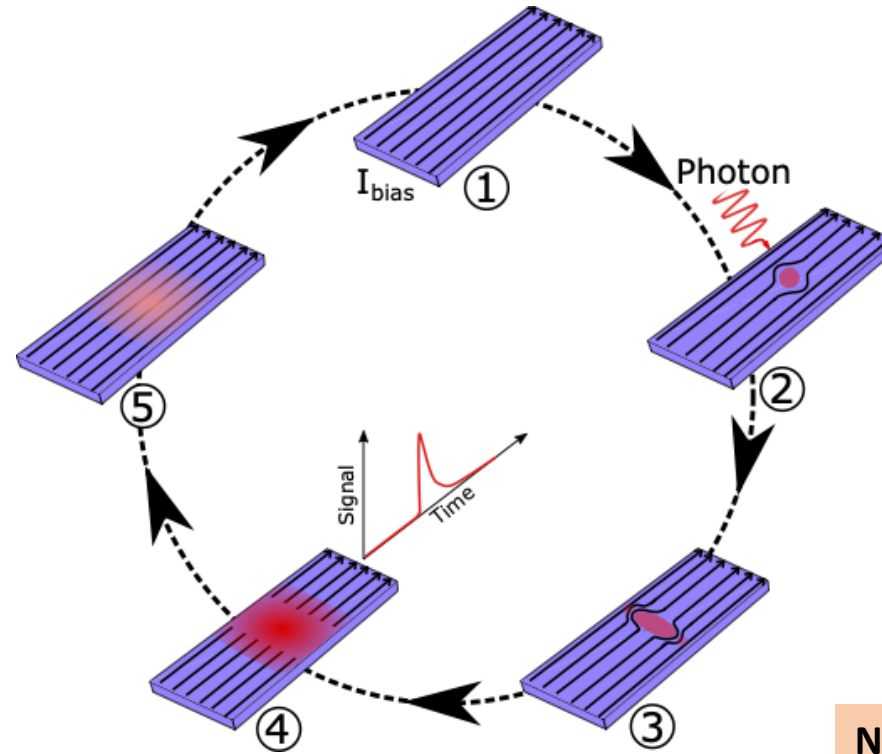

[1] V. Reddy, et al. *Optica* (2020)

[2] V. B. Verma, et al. *APL Photonics* (2021)

[3] B. Korzh, et al. *Nature Photonics* 14.4 (2020)

New Review:

(INVITED) Vidur Raj *et al* 2025 *J. Phys. D: Appl. Phys.* **58** 243001

Highly Customizable

(Patented High Filling Factor Fractal Technology)

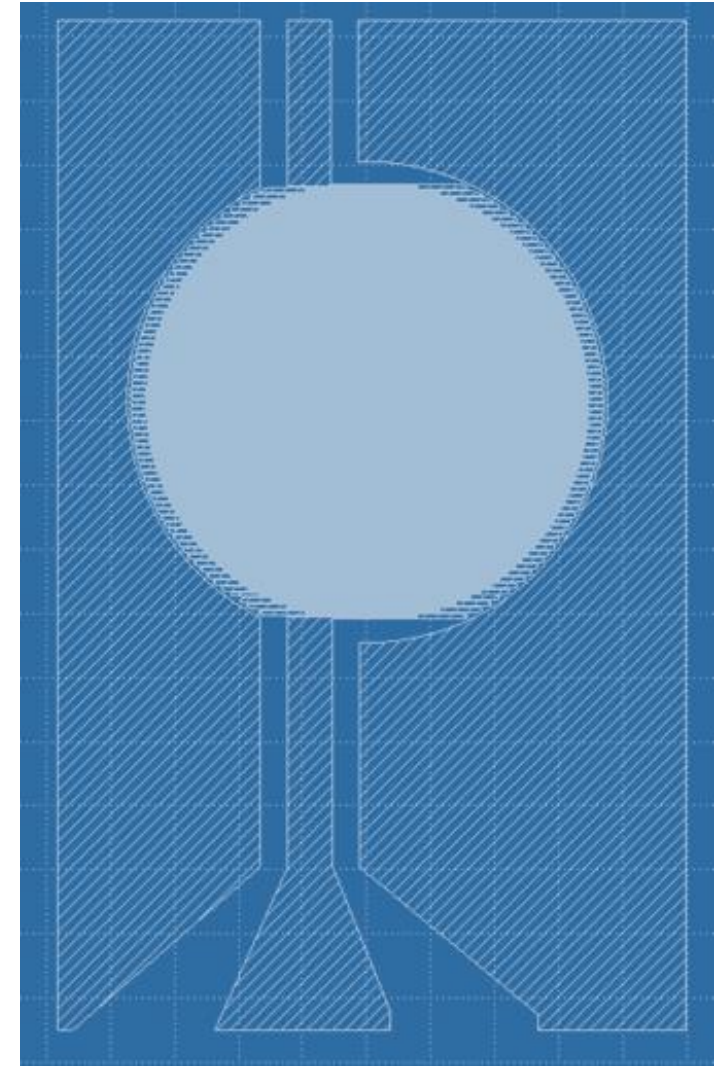
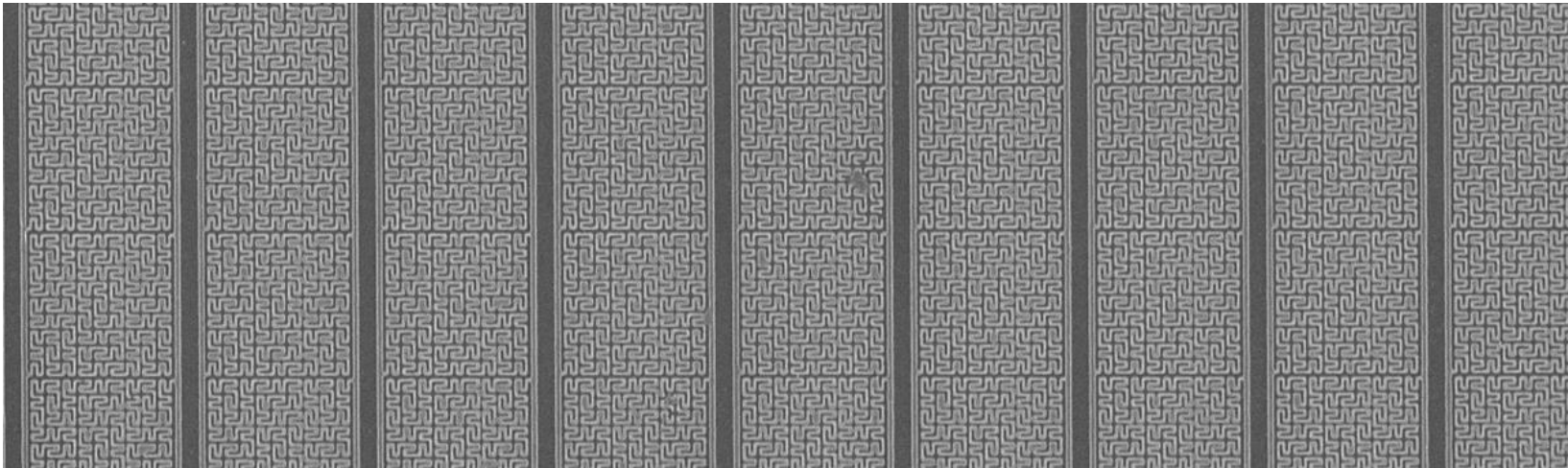
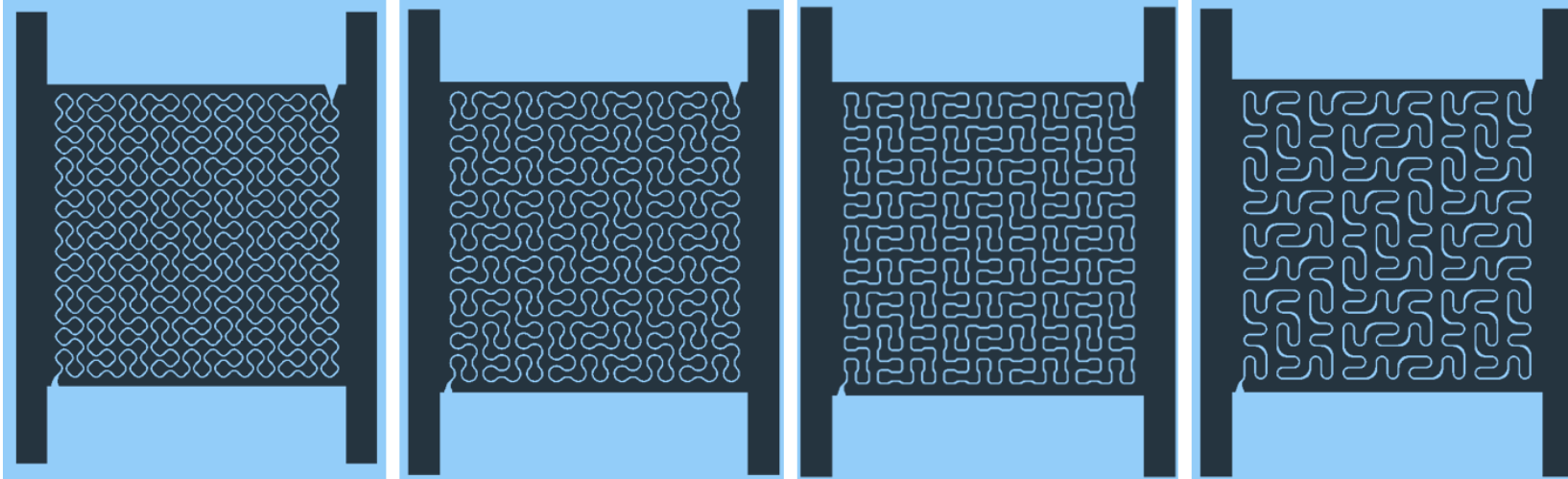

Choose from more than 20 Designs

FUNCTIONALITIES

WIDELY CUSTOMIZABLE



Tunable Spectrum



Large Area



Free Space Aligned



Polarization Independent



Micron SPDs

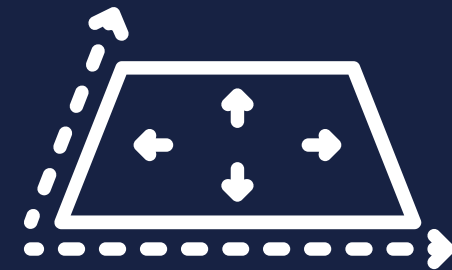

Large Area



University
of Glasgow

RESULTS

MID-IR DETECTION

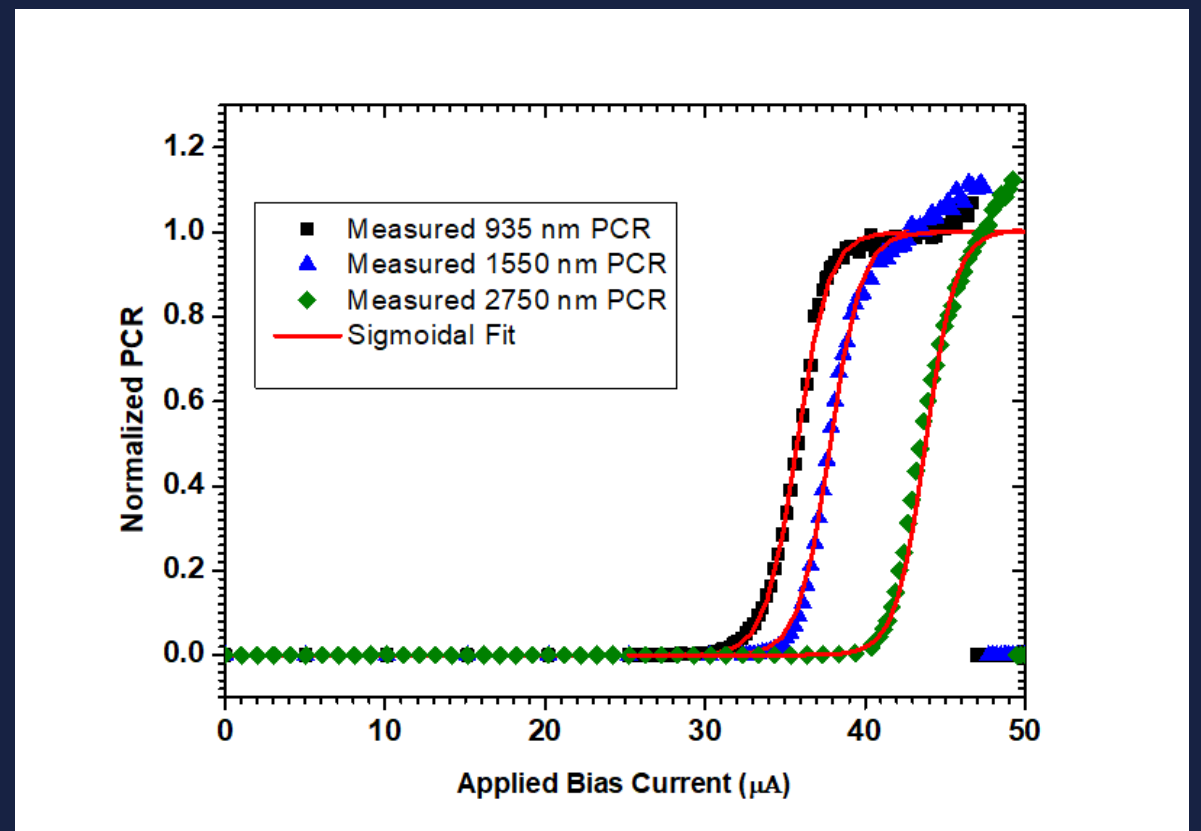
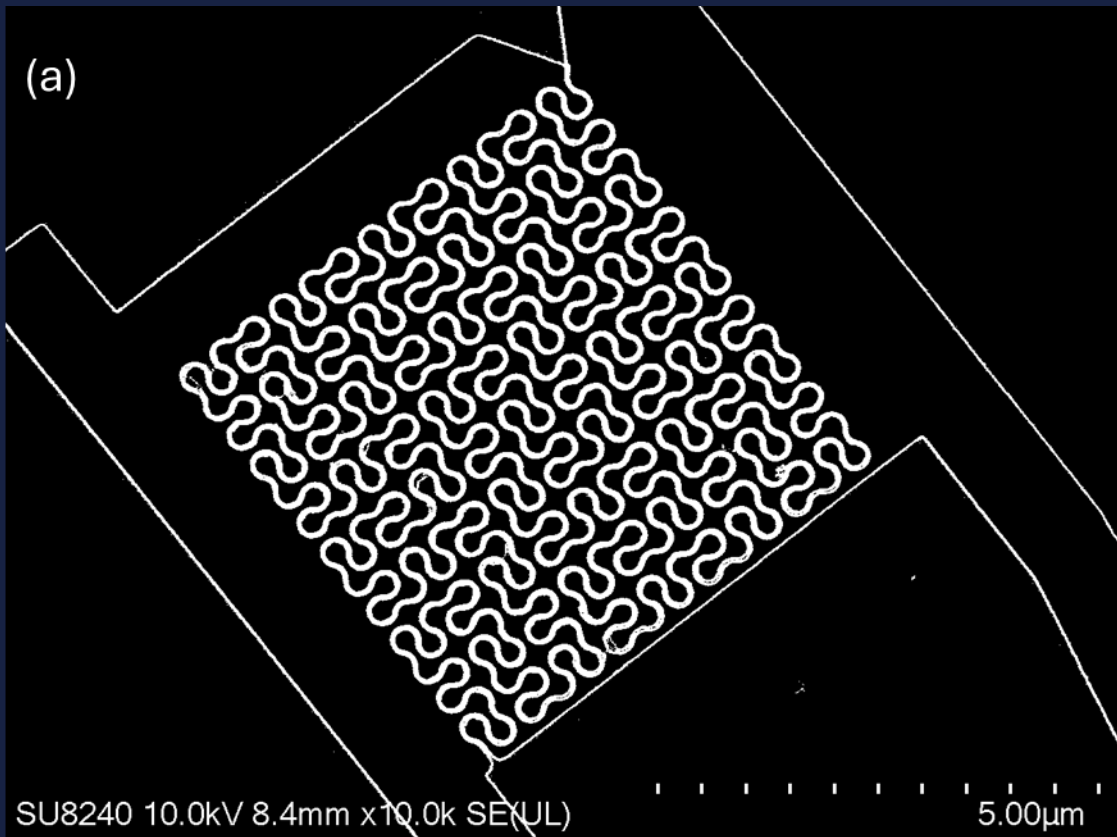

RESULTS

POLARIZATION STUDY



University
of Glasgow

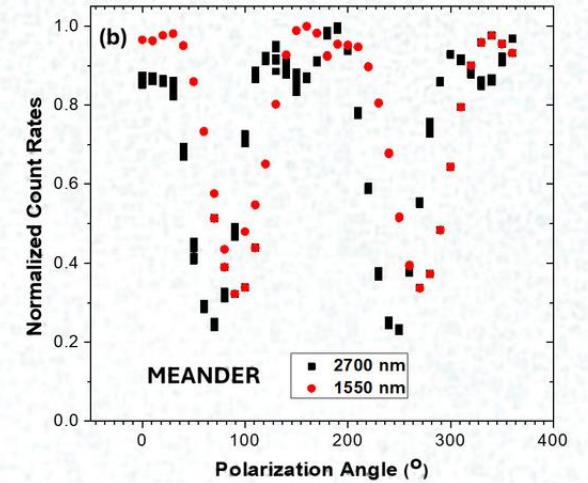
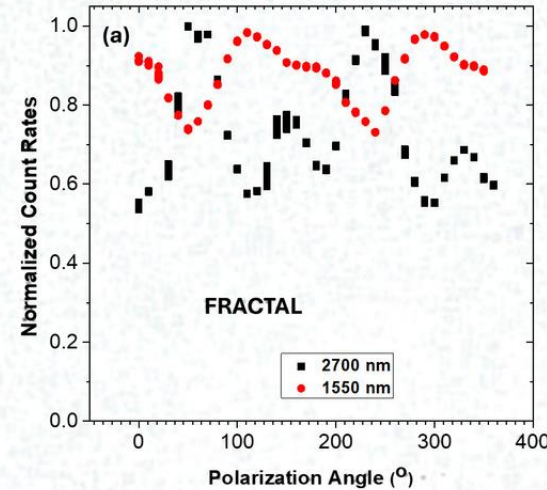
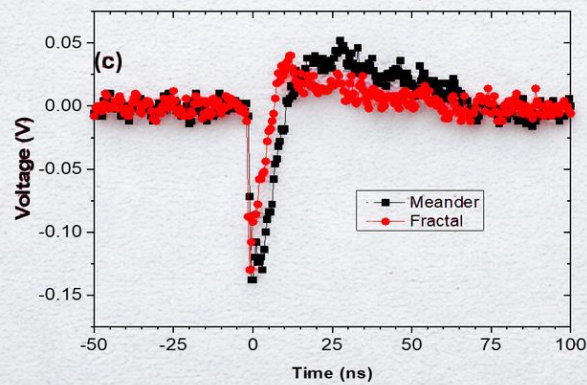
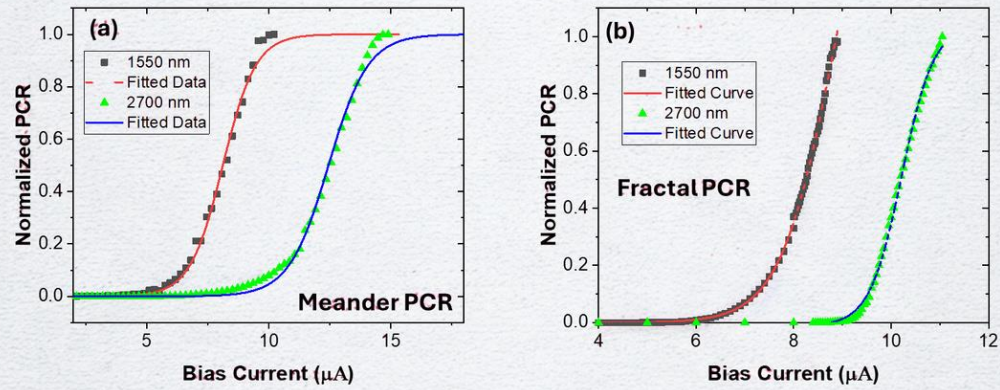

Accepted for publication in APL PHOTONICS

Custom SNSPD Chips

Wide range of customization options, access to cutting-edge SNSPD technology, enables innovation in single-photon detection



Thin Film Optics

High-quality and durable thin films, customized solutions for specific optical requirements, improves efficiency and sensitivity of SNSPDs

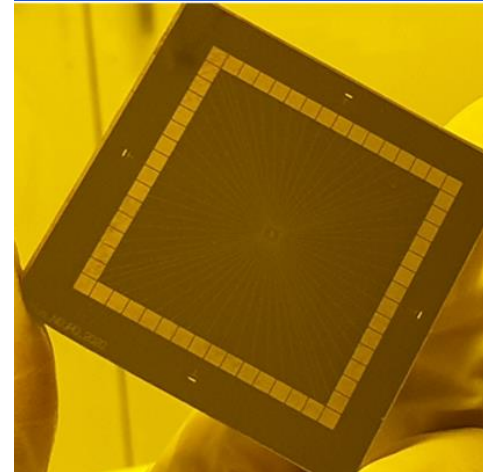

Cryo Electronics

High-performance cryogenic systems, compact and user-friendly design, enables reliable operation of SNSPDs



Ancillary Products that power SNSPD systems

As the first Indian company producing SNSPD systems domestically, Quanastra offers cost and service advantages with **Custom SNSPD Chips, Cryo Electronics and Thin Film Optics.**

This is particularly beneficial for Indian ecosystem promoting self-reliance and technological advancement within the country.

Quanastra's Vision for Future

Our product portfolio expansion in the next 3 to 10 years

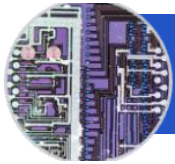

Photonic Quantum Chips

- GHz Quantum Transceivers
- On-chip multi-pixel generation and detection of light for Quantum Computing

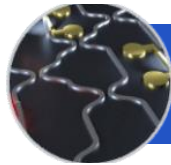

Photonic Integrated Circuits (PICs)

- Augmented and Virtual Reality
- LiDARs
- Photonic Computing
- Biosensing

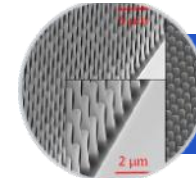

Semi Conductors

- Photon Detectors
- Digital Camera
- Power Meters
- LiDARs
- OTDRs
- Bioimaging Setups

In 10 years, we aim to become the lead manufacturer of Quantum and Photonic chips for world in India.

Minimum Infrastructure For Quantum Technology

Great possibilities for Academia-Industry Collaboration



Nanofabrication and Microfabrication (Only two of them – IITB and IISc) – (They are flooded with jobs)



High Precision Optics

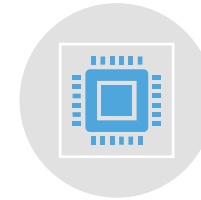

High precision electronics – Oscilloscopes, ps timing electronics, etc.



High Throughput Precision Manufacturing (SS304, Ceramics, New Age Plastics, etc)



Strong Thin-film and alloy deposition capabilities.



Cryogenics



CAD and Simulation Softwares

OUR CONTACT INFO

GET IN TOUCH

Email Address

www.Quanastra.com

Phone Number

+91 920 577 1590

Mailing Address

C15A, Milap Nagar, Uttam Nagar East

Delhi – 110059, India
