

FFA application to the muon collider complex

Max Topp-Muggleston

max.emil.topp-muggleston@cern.ch

Contents:

- Introduction to the muon collider complex
- FFA for muon acceleration
- Introduction to the vFFA
- Parameter studies of the vFFA for muon acceleration
- Decoupled insertions
- FFA collider ring
- Conclusions

The Muon Collider

- Ambitious proposal for energy-frontier and precision-frontier physics
- Accelerate and collide muons
 - Pointlike, leptonic collisions
 - Synchrotron power loss lower than electrons by $\sim 10^9$

Energy reach of a hadron collider
Precision of an electron collider



The perfect option...?

Muon Collider Challenges

- Muon Production
 - Muons need to be produced from impingement of beam on a target
 - Requires a proton driver facility
 - Muon beams are produced with high emittance
 - Cooling is required to reduce emittance (and achieve luminosity goals)
- Muons have a $2.2\mu\text{s}$ lifetime at rest
 - Total acceleration time must be minimized
 - 50% survival over a 63 GeV to 5 TeV acceleration would require millisecond-order cycle time

Muon Collider Complex

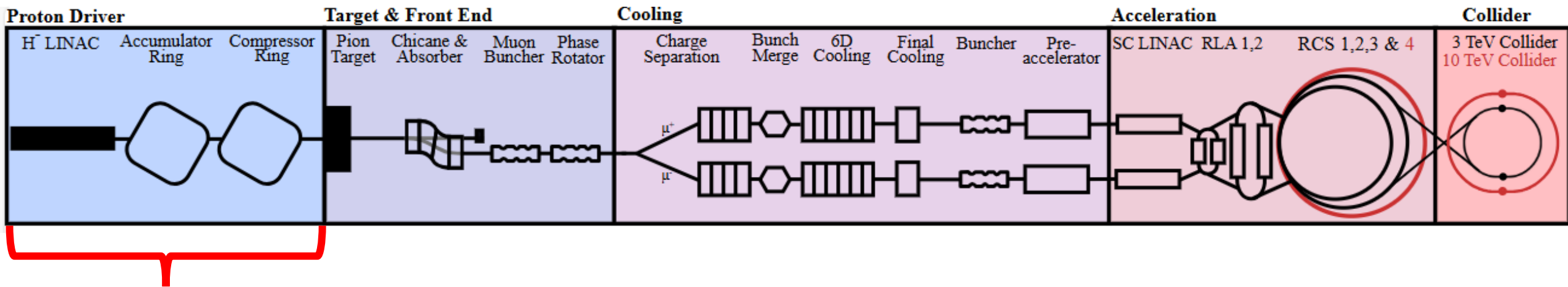

- Requirements:
 - 2 MW at 5 GeV, 4 MW at 10 GeV
 - Pulse length ~2ns
- Full-energy linac + AR + CR
- ‘Single-ring’ option also considered

Muon Collider Complex

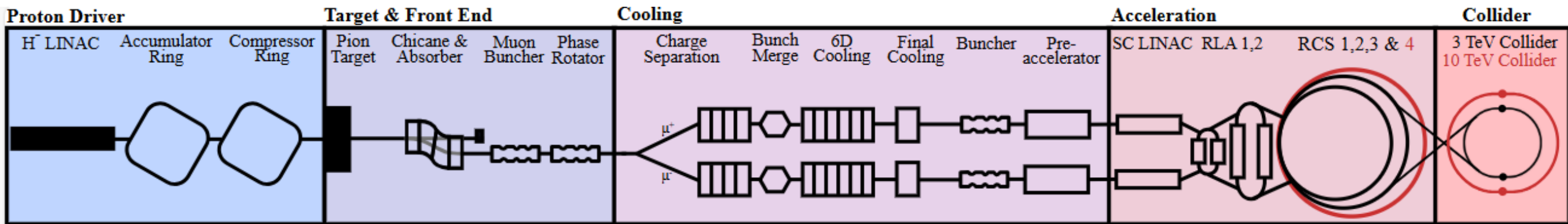

- High-power target station
- Cooling section and pre-acceleration

Muon Collider Complex

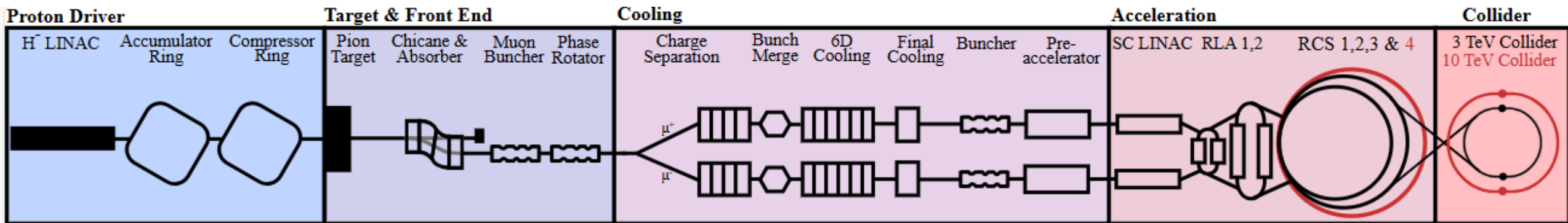

- Low-energy acceleration up to 63 GeV
 - SC linacs + Recirculating linacs
- High-energy acceleration to 3 (10) TeV
 - Baseline design is (hybrid) RCS chain

Muon Collider Complex

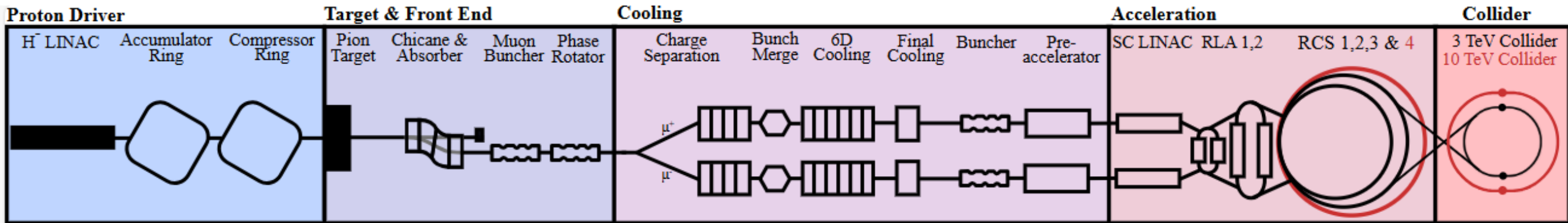

- Hybrid RCS:
 - Interleaved NC/SC magnets

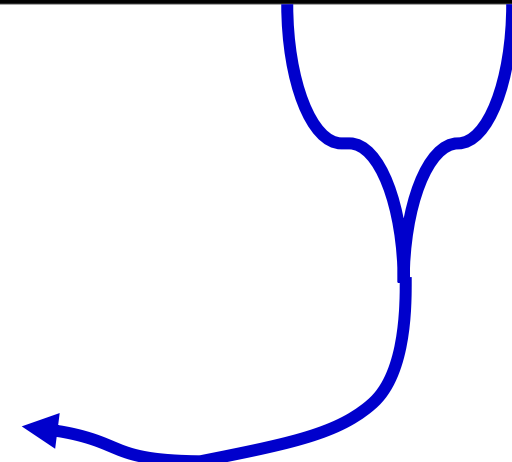
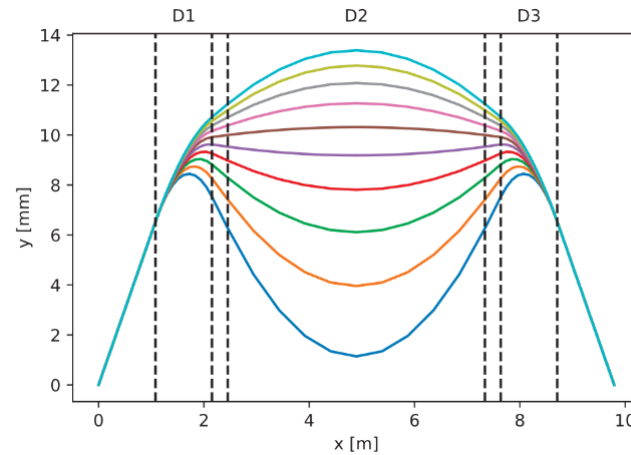

Muon Collider Complex

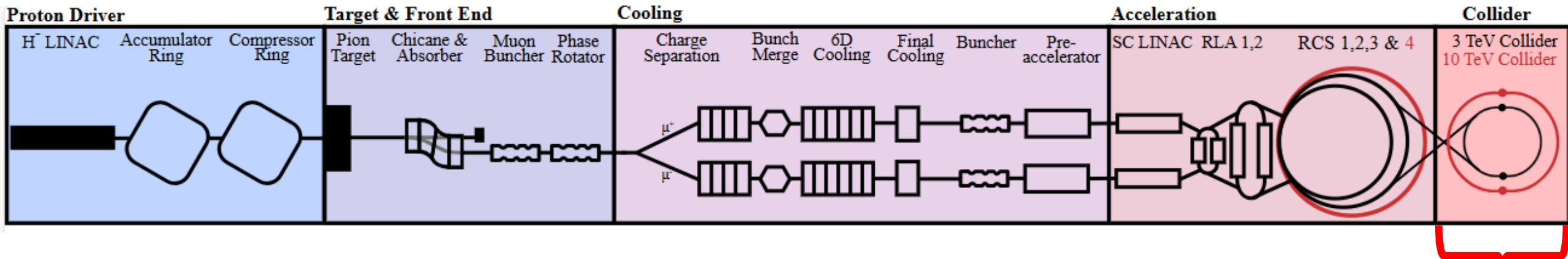

- Dedicated collider ring
 - Challenges due to:
 - Small β^* (large β either side of IP, chromatic effects, aperture limitations)
 - Preserving small bunch length

RCS challenges

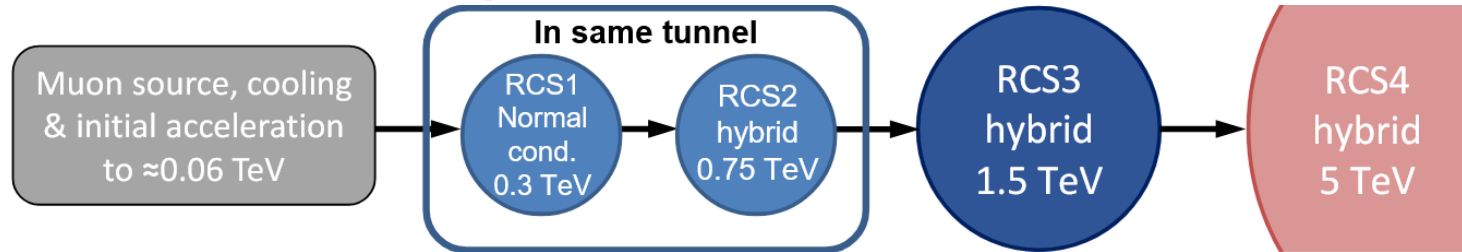

A brief (non-exhaustive) list of problems:

- Ramping magnets
 - Rate of ramping can be limiting factor on muon survival
 - Ramping requires normal-conducting magnets
 - Construction and distribution of power converters, storing energy, etc..
- Changing path length (hybrid RCS)
 - Changing time of flight → requirement for tunable RF ?

4.2 kT/s
ramp rate
in RCS1!

What if we didn't have to deal with any of these?

Fixed Field Accelerators

Time-independent magnetic fields means...

- No ramp times
 - Rate of acceleration limited only by RF
 - Mitigates engineering challenges of designing and powering fast-ramping dipoles
- All magnets can be superconducting
- Orbit position moves when energy changes

Spatial dependence of magnetic fields allows tune control

“Conventional” horizontal-excursion

FFA (hFFA):

Orbits move outwards with increasing energy

Fields increase radially

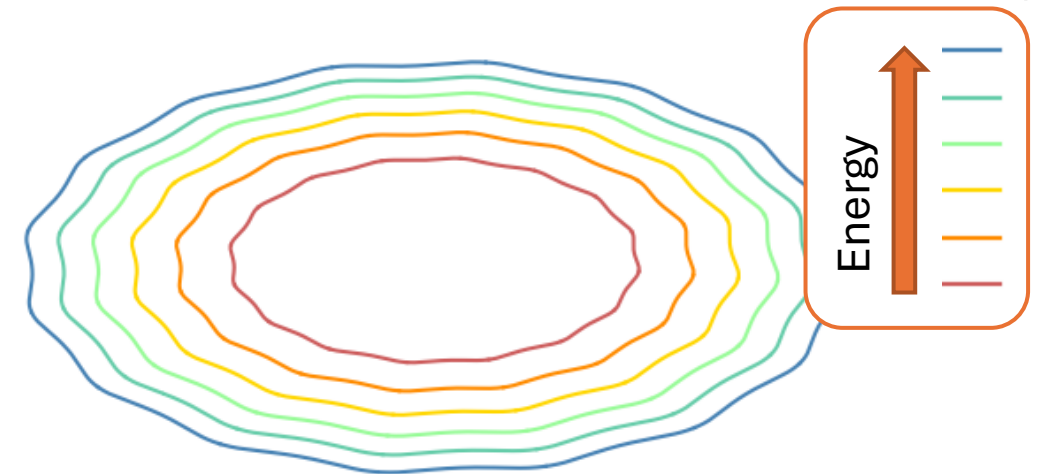

For hFFA options for muon acceleration see presentation by J. Scott Berg in 2023 IMCC meeting or 2022 FFA workshop

NShFFA for muon acceleration

- hFFA proposal for muon acceleration made based on linear optics (J. Scott Berg)
- Designed for Fermilab siting – 16km circumference
- FDF triplet structure
- Possibility of serpentine acceleration
- Example result for factor 2 energy gain (top energy 5 TeV)
 - F field is 12.4 T at outside
 - D field is -5.3 T at outside
 - Excursion is 15 cm

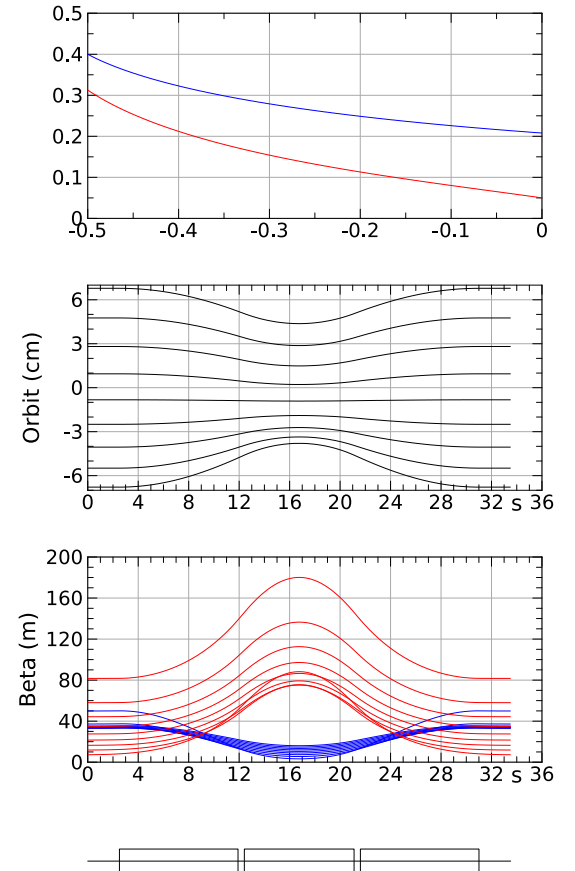

Vertical-Excursion Fixed Field Accelerators

Vertical-excursion FFA (vFFA):

- Higher energy orbits are vertically translated copies of lower energy orbits
- Zero chromaticity if fields increase with vertical coordinate (Z) following scaling law

$$B = B_0 e^{mZ}$$

Zero path length difference means...

- Zero momentum compaction factor α_c
- Transitionless
- Quasi-isochronous for relativistic particles
 - on-crest acceleration can be used

Vertical-excursion FFA (vFFA):

Orbits move upwards with increasing energy
Fields increase vertically

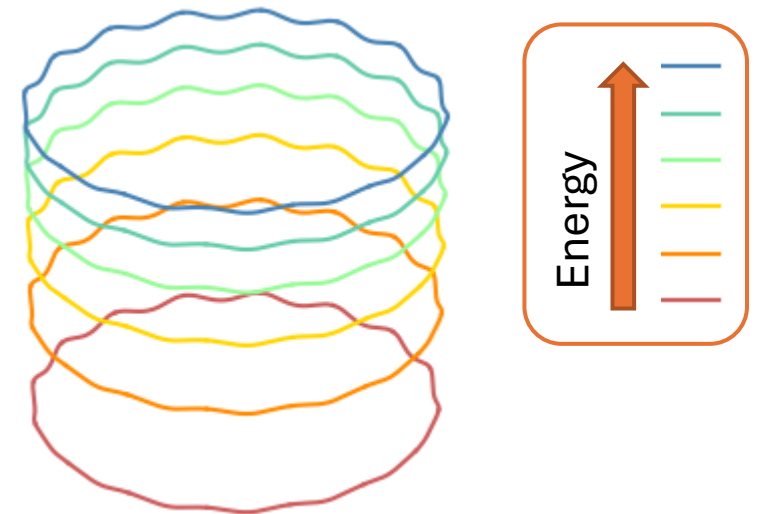

Properties of the vFFA

Non-planar closed orbit

Intrinsically coupled optics

Scaling laws → optics determined by closed orbit and field index m

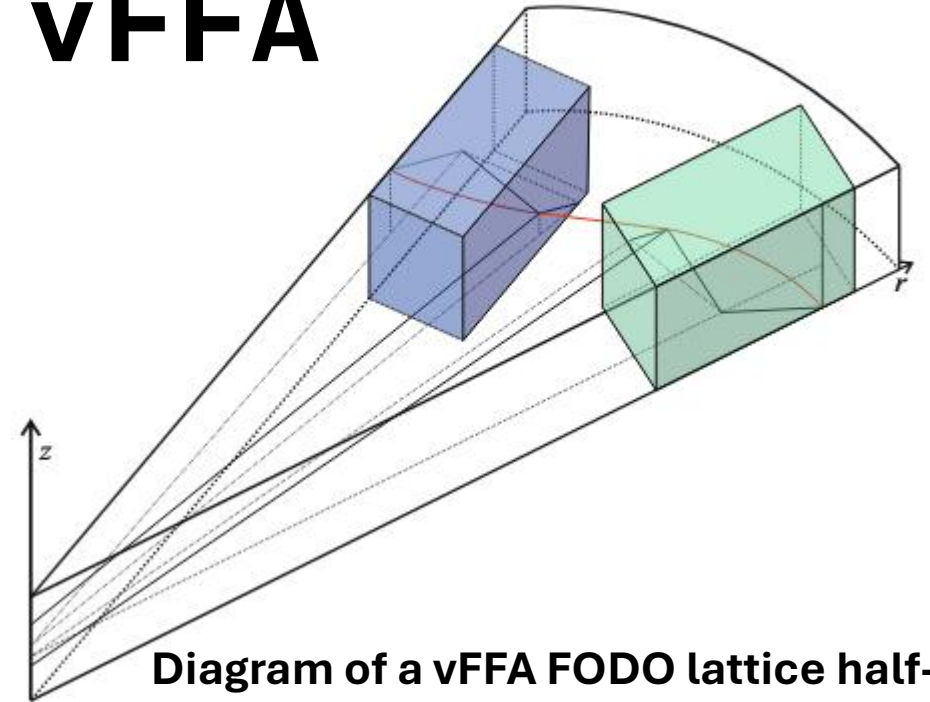

Diagram of a vFFA FODO lattice half-cell

F-magnet is shaded in green; D-magnet is shaded in blue.

Analytic model of vFFA has been developed

“Scaling Fixed Field Accelerators: theory and modelling of horizontal- and vertical-excursion accelerators” – PhD thesis 2024 (See also. FFA 2023 Workshop)

Properties of the vFFA

Closed orbit

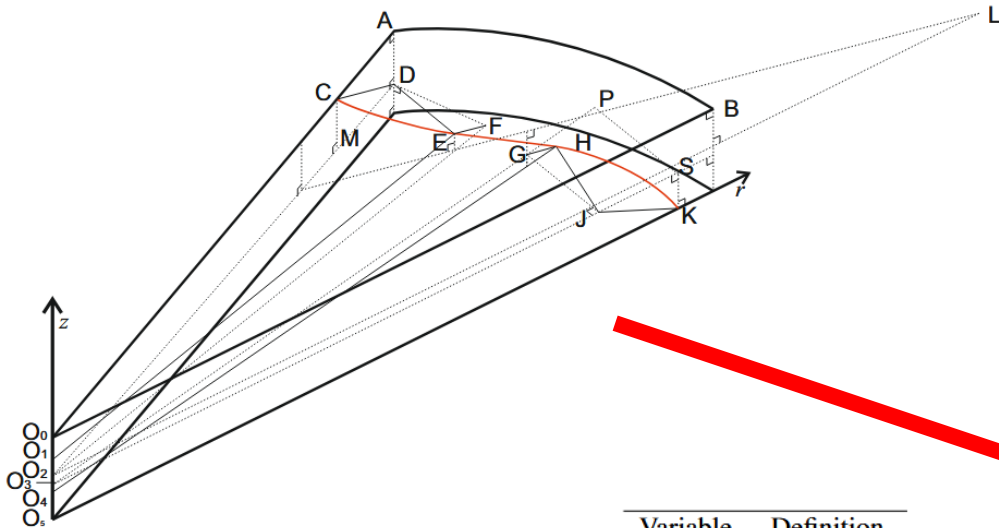

Parameter	Definition	Variable	Definition
β_F	$\angle SO_3P$	θ_D	$\angle CDE$
β_D	$\angle DO_2F$	ρ_F	$\overline{HJ} = \overline{JK}$
$\frac{\pi}{N}$	$\angle AO_0B$	ρ_D	$\overline{CD} = \overline{ED}$
r_0	$\overline{O_5K}$	r_1	$\overline{O_4H}$
θ_F	$\angle HJK$	r_2	$\overline{O_1E}$
γ_F	$\angle SJK$	r_3	$\overline{O_0C}$
		L_s	\overline{EH}
		γ_D	$\angle CDM$

Geometric constraints can be used to determine closed orbit from input parameters

Some important variables for each magnet: ρ, γ, r (radius of curvature, inclination of plane of curvature, radius wrt machine centre)

$$\theta_D = \arctan \left(\frac{\sqrt{(\tan \frac{\pi}{N} - \cos \gamma_F \tan \theta_F)^2 + \sin^2 \gamma_F \sin^2 \theta_F (\tan \frac{\pi}{N} \cos \gamma_F \tan \theta_F + 1)^2}}{\sqrt{1 - \sin^2 \gamma_F \sin^2 \theta_F (\tan \frac{\pi}{N} \cos \gamma_F \tan \theta_F + 1)}} \right),$$

$$\sin \gamma_D = \frac{\sin \theta_F}{\sin \theta_D} \sin \gamma_F,$$

$$\rho_F = r_0 \frac{\tan \beta_F}{\sin \theta_F + (1 - \cos \theta_F) \cos \gamma_F \tan \beta_F},$$

$$r_1 = \rho_F \frac{\sin \theta_F}{\sin \beta_F},$$

$$r_2 = r_1 \frac{\cos \beta_F + \tan \theta_F \cos \gamma_F \sin \beta_F}{\cos (\frac{\pi}{N} - \beta_D) + \tan \theta_F \cos \gamma_F \sin (\frac{\pi}{N} - \beta_D)},$$

$$\rho_D = r_2 \frac{\sin \beta_D}{\sin \theta_D},$$

$$r_3 = r_2 \cos \beta_D - \rho_D (1 - \cos \theta_D \cos \gamma_D).$$

Properties of the vFFA

Closed orbit

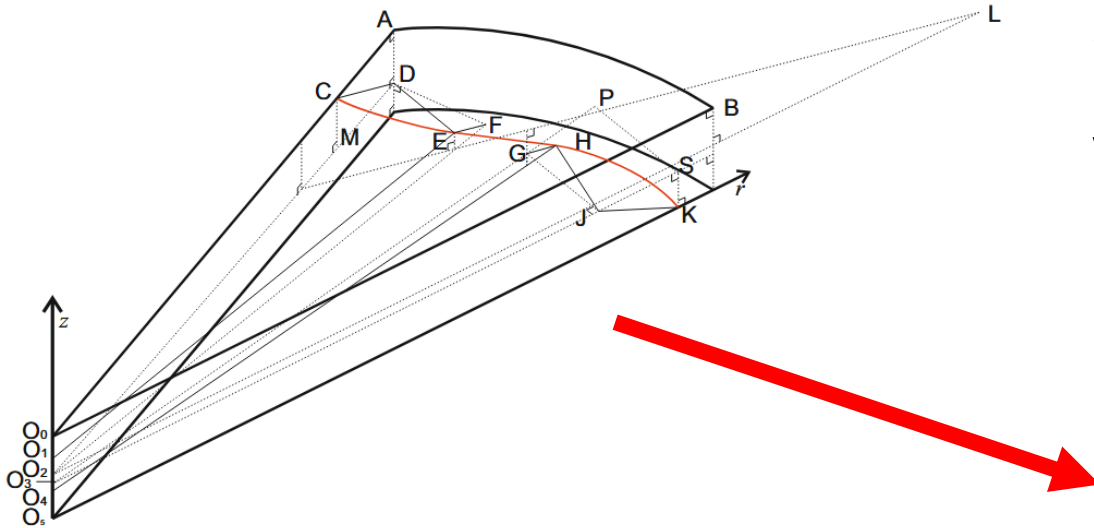

Alternative parameterization:

θ_F, θ_D as inputs

Geometric constraints can be used to determine closed orbit from input parameters

Some important variables for each magnet: ρ, γ, r (radius of curvature, inclination of plane of curvature, radius wrt machine centre)

$$\cos \gamma_F = \frac{\cos \theta_D - \cos \theta_F \cos \frac{\pi}{N}}{\sin \theta_F \sin \frac{\pi}{N}}.$$

$$\sin \gamma_D = \frac{\sin \theta_F}{\sin \theta_D} \sin \gamma_F,$$

$$\rho_F = r_0 \frac{\tan \beta_F}{\sin \theta_F + (1 - \cos \theta_F) \cos \gamma_F \tan \beta_F},$$

$$r_1 = \rho_F \frac{\sin \theta_F}{\sin \beta_F},$$

$$r_2 = r_1 \frac{\cos \beta_F + \tan \theta_F \cos \gamma_F \sin \beta_F}{\cos \left(\frac{\pi}{N} - \beta_D \right) + \tan \theta_F \cos \gamma_F \sin \left(\frac{\pi}{N} - \beta_D \right)},$$

$$\rho_D = r_2 \frac{\sin \beta_D}{\sin \theta_D},$$

$$r_3 = r_2 \cos \beta_D - \rho_D (1 - \cos \theta_D \cos \gamma_D).$$

Properties of the vFFA

Magnet body Hamiltonian

$$\mathcal{H} \simeq \frac{p_x^2}{2} + \frac{p_z^2}{2} - \frac{1}{\rho + \frac{\sin \gamma}{m}} \left[\cos \gamma \left(m + \frac{2 \sin \gamma}{\rho} \right) xz - \frac{1}{2} m (x^2 - z^2) \sin \gamma \right] + \frac{1}{\rho \left(\rho + \frac{\sin \gamma}{m} \right)} (x^2 \cos^2 \gamma + z^2 \sin^2 \gamma)$$

x, z : horizontal and vertical transverse coordinates

m : normalised field gradient

ρ : radius of curvature

γ : inclination (angle of the plane of curvature in magnet)

m is a constant around the ring

→ Sign of focusing terms can only be changed if sign of ρ changes

→ reverse bends are required

Hamiltonian has normal quad + skew quad + geometric terms

vFFA parameter study (stage 1)

Analytic model of vFFA used to develop proposal for equivalent vFFA FODO ring to RCS1 – using ‘FFA designer’ tool

Constraints:

- Footprint no larger than RCS1
- Peak field on orbit <8T
- Drift lengths > 1m
- Excursion < 5 cm

MuCol Milestone 17 Report - WP5 - Tentative design of the FFA (2025)

	RCS1	Stage I vFFA
Circumference [m]	5990	5990
Injection Energy [TeV]	0.06	0.06
Extraction Energy [TeV]	0.3	0.3
NC Ramped Magnets	Yes	No
SC Fixed magnets	No	Yes
Ramp Rate [T/s]	4200	0
Vertical Excursion [m]	0	0.048
Relative path length difference	0.0	0.0
Peak Dipole Field On Orbit [T]	1.8 (NC)	6.93
Peak Dipole Field (Good Field Region) [T]		12.52
Drift length [m]		1.18
Tune		(0.382, 0.079)

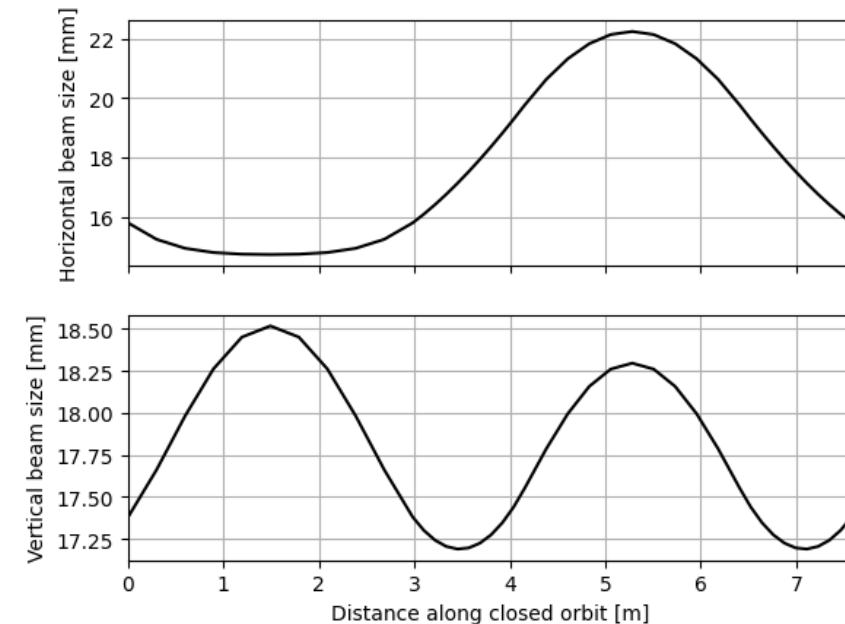

vFFA parameter study (stage 4)

Equivalent vFFA FODO ring to RCS4

Constraints:

- Footprint no larger than RCS4
- Peak field on orbit <16T
- Drift lengths > 1m
- Excursion < 10 cm

MuCol Milestone 17 Report - WP5 - Tentative design of the FFA (2025)

	RCS4	Stage 4 vFFA
Circumference [m]	35000	35000
Injection Energy [TeV]	1.5	1.5
Extraction Energy [TeV]	5	5
NC Ramped Magnets	Yes	No
SC Fixed magnets	Yes	Yes
Ramp Rate [T/s]	565	0
Vertical Excursion [m]	0	0.099
Relative path length difference	1.71×10^{-6}	0.0
Peak Dipole Field On Orbit [T]	16	13.59
Peak Dipole Field (Good Field Region) [T]		29.04
Drift length [m]		1.03
Tune		(0.460, 0.057)

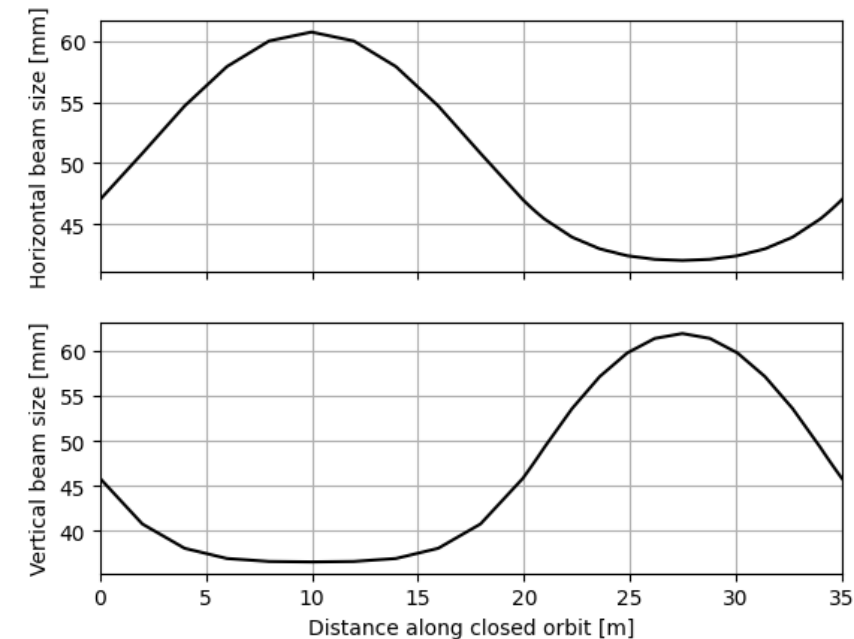

vFFA parameter study conclusions

Simple vFFA FODO lattices have been proposed based on analytic formalism

Equivalent vFFA lattices to baseline RCS1, RCS4 exist with

- **No ramped magnets**
 - Fully SC
 - No issues for power converter, energy storage
- **No requirement for RF frequency ramping**
- Zero momentum compaction
- Fixed tunes
- Possibility of **on-crest acceleration** (potential $\sqrt{2}$ improvement in accelerating voltage for given cavity power)
- Excursion less than: 5 cm (vFFA1), 10 cm (vFFA4)
- On-orbit dipole fields less than: **7 T** (vFFA1), **13.6 T** (vFFA4)

Remaining Design Objectives

Longitudinal behaviour of the vFFA has not been studied in this regime

- How will bunch structure change after passing through isochronous machine?
 - Is there a need to perturb isochronicity to preserve longitudinal properties of bunch?
- 6D simulation is needed

Large change in orbit position can be problematic for acceleration

- High-frequency RF cavities have limited aperture
- Off-axis beam in RF cavities will excite high order modes (HOMs)
- Coupling between transverse and longitudinal planes
 - Increases need for distributed RF

High normalized field gradient m → rapid growth of fields away from axis

Coupled optics → how do we design an extraction system?

Two takeaways:

- **Full 6D numerical simulation of vFFA lattices must be completed**
- **Are there ways to mitigate some of the other problems?**

Number of
turns
RCS1 : 17
RCS4 : 55

vFFA1 Simulation

vFFA1 has been simulated using the FFA code FIXFIELD

- Analytic model was able to predict closed orbit, position magnets, and identify valid lattice in previously untested region of parameter space
- Disagreement between analytic model and simulation on range of stable m-values → excursion of simulation is larger than analytic model ($m \sim 21/m$ numerical, $m \sim 30/m$ analytic)
- However, demonstrated success of analytic model for finding new lattices and use of analytic model insights to optimize lattice

6D tracking studies now underway!

vFFA1 simulation to be used as testbed for of **further concepts**

Coupling in the vFFA

Magnet body Hamiltonian

$$\mathcal{H} \simeq \frac{p_x^2}{2} + \frac{p_z^2}{2} - \frac{1}{\rho + \frac{\sin \gamma}{m}} \left[\cos \gamma \left(m + \frac{2 \sin \gamma}{\rho} \right) xz - \frac{1}{2} m (x^2 - z^2) \sin \gamma \right] + \frac{1}{\rho \left(\rho + \frac{\sin \gamma}{m} \right)} (x^2 \cos^2 \gamma + z^2 \sin^2 \gamma)$$

geometric terms – always present
skew quad term – proportional to $\cos \gamma$
normal quad term – proportional to $\sin \gamma$

If $\gamma = 90^\circ$, we can remove the coupling in this Hamiltonian!

However... cells need at least 2 magnets.

Closed orbit equations

$$\sin \gamma_D = \frac{\sin \theta_F}{\sin \theta_D} \sin \gamma_F,$$

$\gamma_F = \gamma_D$ only if $\theta_F = \theta_D$

Decoupled insertions

- Inclination of both magnets can be 90° if the net bending angle of the cell is zero

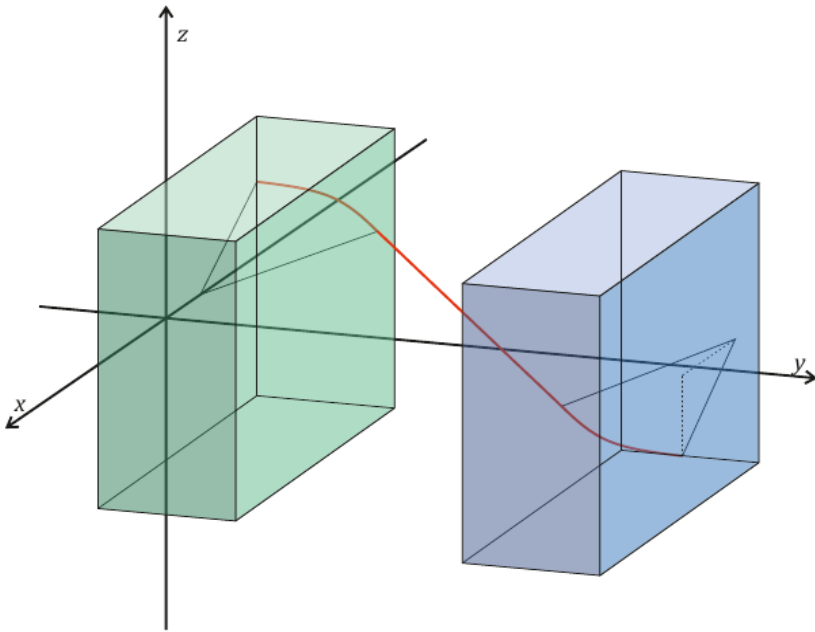

- A straight insertion with a 90° inclination enables the complete negation of coupling over the length of the straight
- Analytic theory for vFFA straight cell design has been completed
- N.B. a vFFA FODO straight with a 90° inclination is equivalent to an hFFA FODO straight - hFFA straight cells have been tested experimentally (J.-B. Lagrange, *Study of zero-chromaticity in FFAG accelerators*. PhD thesis, Kyoto U., 2012.)

Decoupled insertions

When optics are decoupled:

- **Orbit can be kicked/bumped in one plane without affecting the other**
 - Injection and extraction design becomes much less restrictive
- **Betatron oscillations can be induced in the dispersive plane**
 - Possibility of mitigating transverse/longitudinal issues from RF by tuning cell phase advance between cavities
 - Enables design of dispersion suppressors

Dispersion suppression

In a decoupled straight:

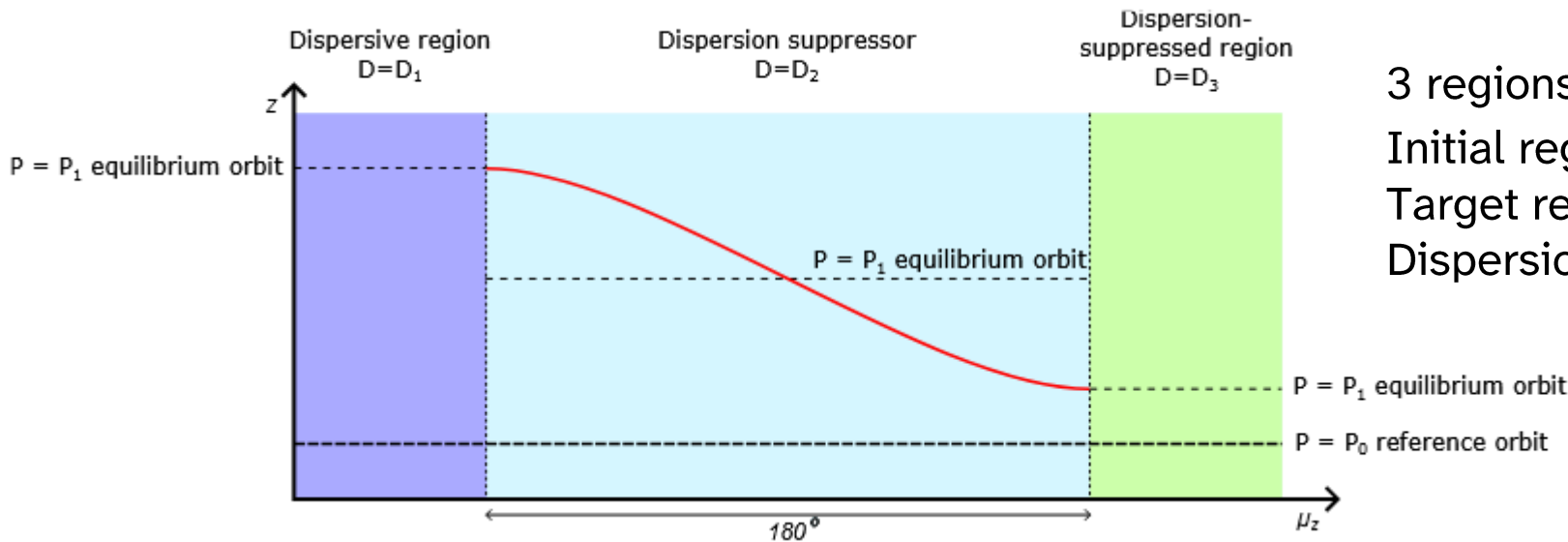

3 regions with different dispersions $D_Z = \frac{1}{m}$
Initial region: D_1 is at nominal value for arcs
Target region: D_3 is at desired value (can be zero)
Dispersion suppressor: $D_2 = (D_1 + D_3)/2$

Allows separation of arc excursion from RF constraints:

More freedom in choice of arc parameters · lower demands on aperture of RF · lessen severity of HOM issues

Matching Decoupled Insertions

Zeroth-order matching: closed orbits, dispersion must be matched – m value must be the same

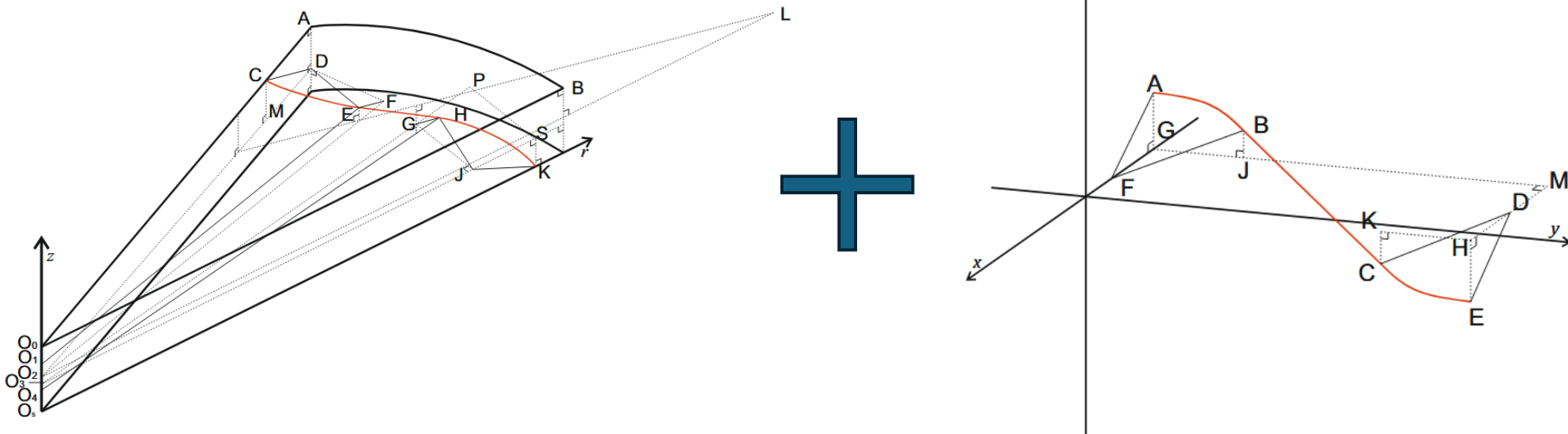

- If cells are joined at magnet midpoints, their inclinations are independent. This may not be practical to implement.

Matching Decoupled Insertions

*without specialist extra matching cells or magnets

To match in a drift*, an arc with a non-zero inclination can be joined to a straight with 90 degree inclination

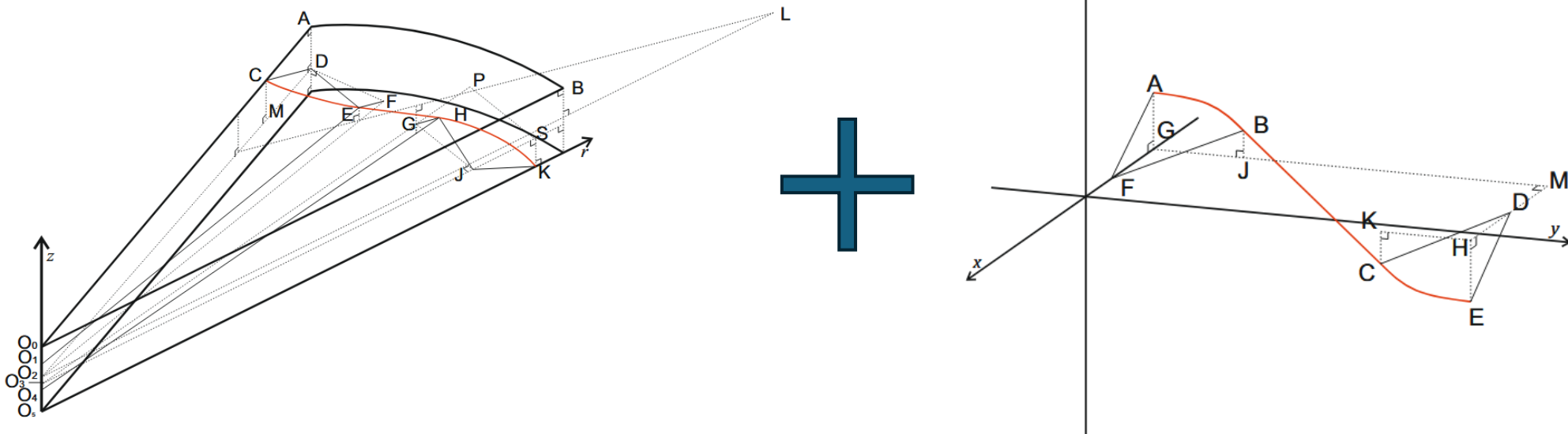

- Constrains $\theta_F = \theta_D$ in straight s.t. $\sin \theta_a \sin \gamma_a = \sin \theta_s$

Matching decoupled insertions

- Matching coupled to decoupled first order optics is not intuitive
 - Consider adiabatic transition of gamma
 - Consider transparent (180 deg phase advance) insertion
- Next objective of vFFA simulation: study inclusion of decoupled insertion

NSvFFA Collider Ring

S. Machida, Eur. Phys. J. Plus **137**, 489 (2022).

- Nonplanar orbit

- Chromaticity correction with normal and skew Sextupole

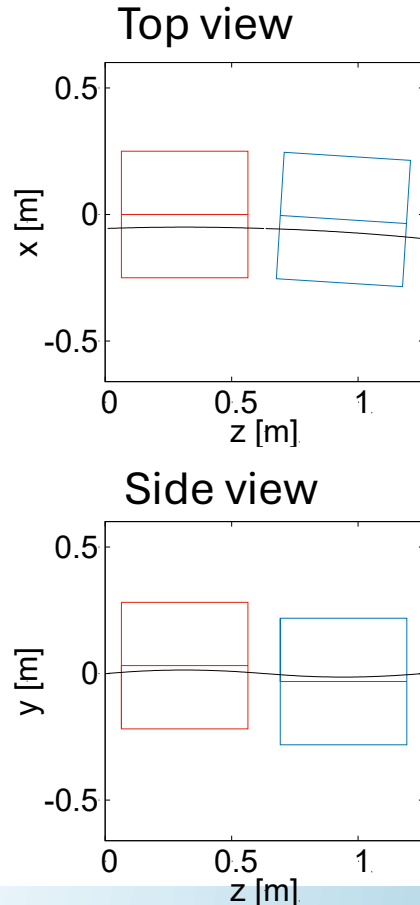

CDM: Combined Defocusing Magnet
CFM: Combined Focusing Magnet

	CDM	CFM
reference momentum [GeV/c]	1.0	1.0
normal dipole b_{0n} [T]	0.629	0.629
skew dipole b_{0s} [T]	-1.00	1.00
skew quadrupole b_{1s} [T/m]	-20.0	20.0
normal sextupole b_{2n} [T/m ²]	-27.5	27.5
skew sextupole b_{2s} [T/m ²]	-55.0	-55.0

$$b_x = b_{0s} - b_{1s}x - b_{2s}(3x^2 - 3y^2) + b_{2n}(6xy),$$

$$b_y = b_{0n} + b_{1s}y + b_{2s}(6xy) + b_{2n}(3x^2 - 3y^2).$$

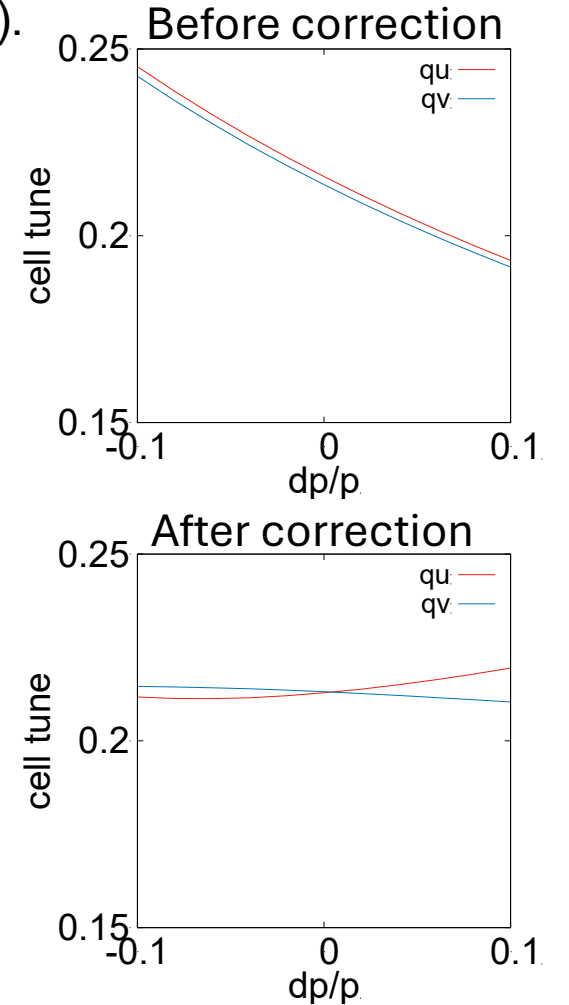

Conclusions

- **vFFA equivalents to RCS1, RCS4 have been proposed using analytic model**
 - vFFA RCS1 equivalent has been simulated numerically
- **vFFA FODO rings can be built with**
 - Equivalent footprint to RCS designs · Achievable dipole fields · Fully superconducting magnets · Small orbit excursion
 - **...for an energy-efficient, zero-chromatic, isochronous accelerator**
- **Coupling effects can be negated in straights**
 - Could help solve injection/extraction issues + dispersion suppression
- **Use of dispersion suppression allows**
 - Dispersion-suppressed RF insertions · Increased freedom in choice of normalised field index in arcs (possibility to lower peak fields)
- **NSFFA proposals have been made:**
 - NSvFFA collider ring for zero momentum compaction · NShFFA accelerator ring
- **FFA designer code updated for scaling vFFA (release soon!)**

The future

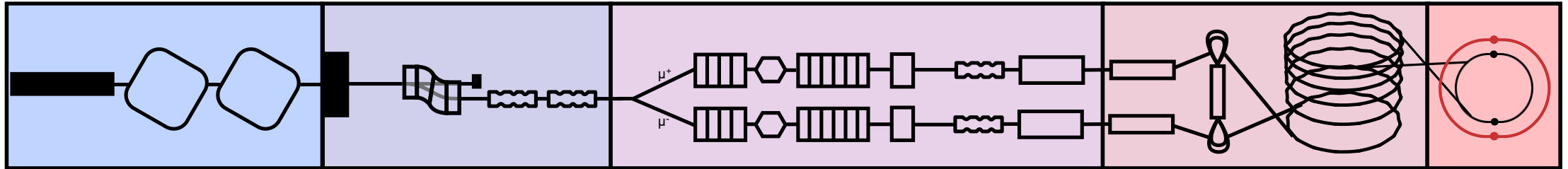

- **vFFA offers promising alternative to RCS for muon acceleration**
 - Able to circumvent a number of key issues
- Analytic design tool enables **development of new lattices**
- **Further development** of the concept is needed
 - Tradeoffs and potential mitigation strategies have been identified
 - Decoupled straights – already tested in simulation and with experiment (straight hFFA), 1st order matching to vFFA arc untested
 - Dispersion suppression – already tested independently in simulation for straight hFFA
 - Integrated end-to-end 6D simulation must be completed

Further reading / Sources

- Muon collider information:
 - General overview: presentations by C. Carli @ FFA2022, R. Taylor @ IMCC2025 (or ask Chris Rogers)
 - Linear NShFFA: S. Berg @ IMCC2023
 - Scaling vFFA: MuCol Milestone 17
 - Linear NSvFFA: S. Machida, Application of the FFA concept to a Muon Collider Complex, IPAC2021
- FFA information:
 - vFFA theory: M. T-M, **Scaling fixed field accelerators: theory and modelling of horizontal- and vertical-excursion accelerators**, PhD thesis