



# MICE CM3 1

## Magnetic Shielding Update

Mike Courthold



Science & Technology  
Facilities Council

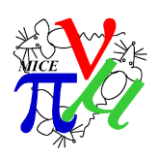

# MICE Magnetic Shielding Walls

## Reason for their Existence

- The MICE Magnetic Shielding walls were designed to limit the field at the periphery of the MICE Hall (with the exception of the roof) to 5 Gauss (0.5mT)
  - This is a self-imposed limit by RAL & CERN by “Best Practise”, due to the possibility that members of the public with Pace-Makers might be present in the ISIS & MICE Control Rooms
  - NB: This is not a limit imposed by legislation – which requires warning signs wherever fields in excess of 5 Gauss might be present
  - The problem with Pace-Makers is in fact limited to older units, which are switched by a heart specialist between normal and data-downloading modes by means of a magnet; and if accidentally switched into data-downloading mode, the battery runs down within a few weeks.
  - ISIS have also imposed a notional limit of 5 Gauss at the wall of the Injector Hall, to prevent fringe field from affecting the ISIS LINAC
    - NB: This limit has never been formally justified by ISIS



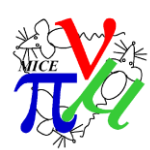

# MICE Magnetic Shielding Walls Design Aims

- The Cooling Channel magnets were designed without yokes, to avoid compromising beam optics, and to avoid complicating their construction; thus magnetic shielding walls were required to limit the fringe field to the MICE Hall.
- Lengthy studies showed that the majority of the fringe field could be contained by means of two parallel walls of good-quality magnetic steel, US1010, of suitable dimensions (US1010 steel is almost twice as effective as mild steel). However, this approach has limitations:
  - Although it is relatively easy to reduce fields from 6 Tesla down to 20-50 Gauss on the far side of such walls, it is virtually impossible to reduce stray field down to 5 Gauss without 100% shielding on all sides. For practical reasons, the shielding walls cannot completely enclose the Cooling Channel, so some field will always circumnavigate the walls.
  - The non-yoke approach to magnet shielding results in extremely high fields within the MICE Hall, which create significant, but manageable, functional and safety issues with magnetically-sensitive equipment and ferrous objects.
- The magnetic shielding walls were initially designed to contain the fields produced by the whole Cooling Channel (ie Step 6), operating in Flip Mode at 240 MeV/c Beta 42, or the more severe Solenoid Mode at 200 MeV/c Beta 7.
- The shielding wall design had to be revised subsequently, but prior to manufacture, to accommodate the desire to operate MICE in Solenoid Mode at 240 MeV/c Beta 42





# Phase VI, Solenoid mode, 240MeV/c VF Opera Magnetic Shielding Wall Model

4/Feb/2011 14:38:21

MICE system and shiel

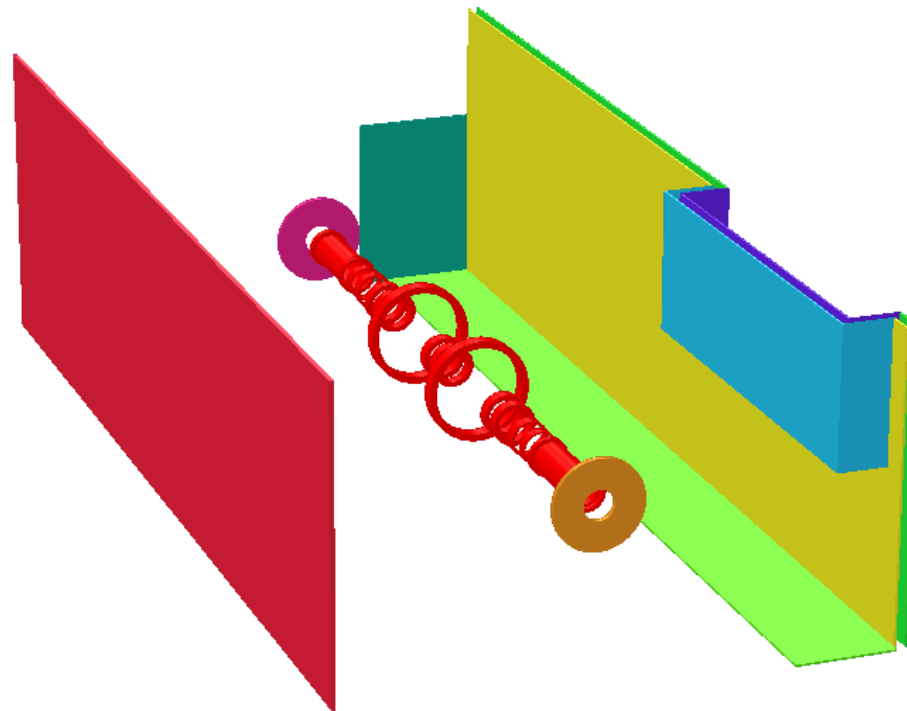



# Phase VI, Solenoid mode, 240MeV/c

## Problem with conductor definition file

- The need to resign the magnetic shielding walls with new Cooling Channel data resulted in two significant errors being introduced into the superconducting coil definition data used in the VF Opera code:
  - One error resulted in a form of Flip-mode, rather than the intended Solenoid-mode, being used in the analysis for Step 6, which significantly underestimated the resultant fringe field (4.8 & 2.3 Gauss for the ISIS CR and MICE CR resp', instead of 17.5 & 15 Gauss)
  - Another error created the effect of two, rather than one, Coupling Coils in the analysis for Step 5.
  - These errors were not discovered until after the shielding walls had been erected.
- The errors in the analysis data were corrected, and the analysis rerun for Steps 4 – 6 in Solenoid and Flip modes, at 240 MeV/c Beta 42 in each case. As a result, it was found that the shielding walls were unable to contain the entire field in Step 6 Solenoid mode – see following table; and work began to find solutions to this problem.
- It can be seen from the table that the existing magnetic shielding wall contains the stray magnetic field sufficiently well, except for Solenoid mode at 240MeV/c Beta 42 in Steps 6 and 5, and would be particularly poor in the unlikely “worst case” combination of magnet currents. This last case demonstrates that the analysis would need to be rerun for any significant change to agreed magnet currents.





# Phase VI, Solenoid mode, 240MeV/c

## Problem with conductor definition file - cntd

Extrnl Wall Gauss	ISIS CR Gauss	MICE CR Gauss	Peak Bmod Tesla	Step	MeV/C	Beta in cm	Flip or Solenoid	Comments
18.9	17.5	15	5.64	6	240	42	Solenoid	TRD values
1.92	1.24	1.43	6.07				Flip	
8.77	7.79	5.92	5.61	5			Solenoid	
2.5	1.9	0.68	6.1				Flip	
2.13	1.86	1.18	4.04	4			Solenoid	
1.5	0.92	0.3	4.05				Flip	
2	1.69	0.97	4.05	3			Solenoid	
1.38	0.73	0.23	4.06				Flip	
12.7	11.9	10		6	200	42	Solenoid	TRD values
1.4	1.14	1.35					Flip	
5.7	4.9	4		5			Solenoid	
1.88	1.44	0.46					Flip	
4.89	4.27	4.26		6	200	7	Solenoid	TRD values
7	4.83	2.33		6	240	42	Solenoid	Actual data - wrong cond data
3.49	2.93	3.15		6	200	7	Solenoid	Original data according to Palmer
1.2	0.9	0.89		6	240	43	Flip	
18.9	17.5	14.9		6	240	42	Solenoid	TRD values - with floor supports included
26.7	24.5	21.9		6	worst	worst	Solenoid	TRD values - worst case combinations

The analysis code was thoroughly checked for errors and accuracy, and then for possible solutions to the stray field issue, by Vector Fields consultant, John Simkin. The quality of the iron used for the shielding walls was also checked by NPL





# Phase VI, Solenoid mode, 240MeV/c Beta 42

## Field contour plot on south wall of MICE Hall

11/Jul/2011 00:25:10

Map contours: BMOD

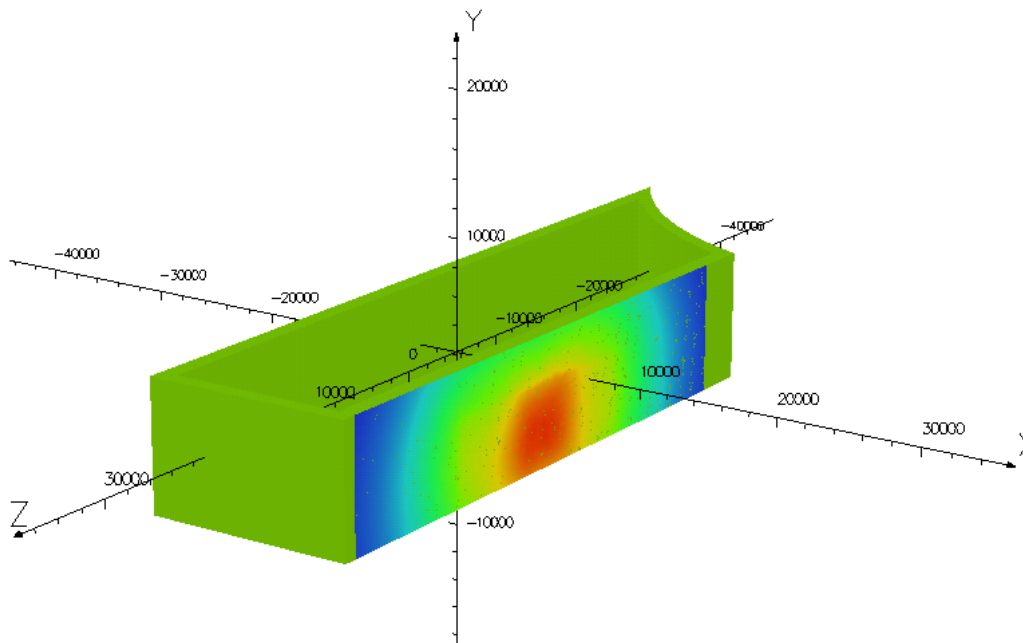
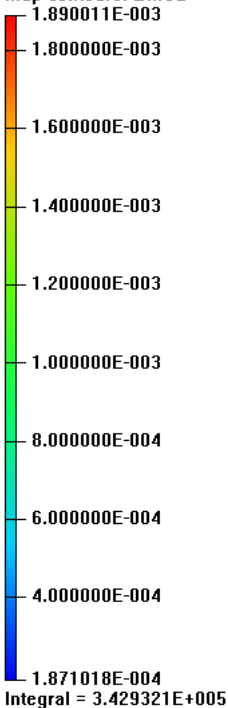

contour map along wall on control

UNITS		
Length	mm	
Magn Flux Density	T	
Magn Field	A m <sup>-1</sup>	
Magn Scalar Pot	A	
Magn Vector Pot	Wb m <sup>-1</sup>	
Elec Flux Density	C m <sup>-2</sup>	
Elec Field	V m <sup>-1</sup>	
Conductivity	S mm <sup>-1</sup>	
Current Density	A mm <sup>-2</sup>	
Power	W	
Force	N	
Energy	J	
Mass	kg	

---

MODEL DATA		
model_xt25c6s240b42.op3		
TOSCA Magnetostatic		
Nonlinear materials		
Simulation No 1 of 1		
3341264 elements		
2319728 nodes		
18 conductors		
Nodally interpolated fields		
Activated in global coordinates		

---

Field Point Local Coordinates		
Local = Global		

---

FIELD EVALUATIONS			
Cartesian	CARTESIAN	300x300	Cartesian
	(nodal)		
	x=6106.0	y=-2370.0 to z=20000.0	
		6545.4	-20000.0





# Phase VI, Solenoid mode, 240MeV/c Beta 42

## Field contour plot on south wall of MICE Hall at intersection with ISIS Control Room

11/Jul/2011 00:26:48

Map contours: BMOD

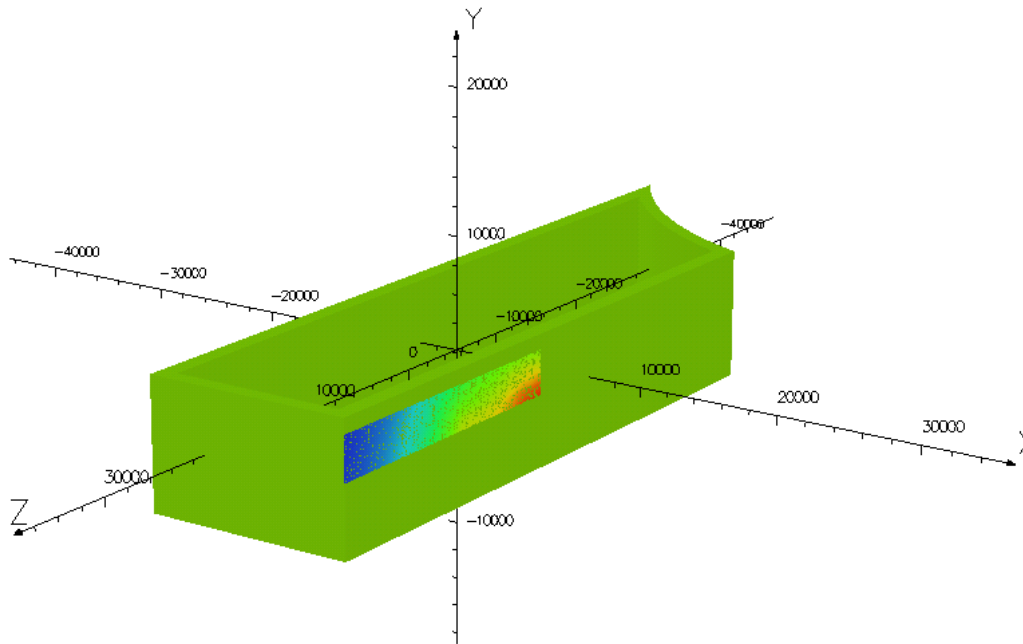
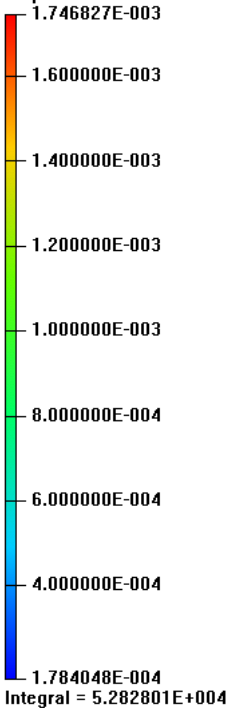

ISIS CONTROL ROOM V

UNITS		
Length	mm	
Magn Flux Density	T	
Magn Field	A m <sup>-1</sup>	
Magn Scalar Pot	A	
Magn Vector Pot	Wb m <sup>-1</sup>	
Elec Flux Density	C m <sup>-2</sup>	
Elec Field	V m <sup>-1</sup>	
Conductivity	S mm <sup>-1</sup>	
Current Density	A mm <sup>-2</sup>	
Power	W	
Force	N	
Energy	J	
Mass	kg	

---

**MODEL DATA**

model\_xt25c6s240b42.op3  
 TOSCA Magnetostatic  
 Nonlinear materials  
 Simulation No 1 of 1  
 3341264 elements  
 2319728 nodes  
 18 conductors  
 Nodally interpolated fields  
 Activated in global coordinates

---

**Field Point Local Coordinates**

Local = Global

---

**FIELD EVALUATIONS**

Cartesian	CARTESIAN (nodal)	300x100	Cartesian
	x=6106.0	y=2505.0 to z=20995.0 to 5505.0	400.0







# Phase VI, Solenoid mode, 240MeV/c Beta 42

## Field contour plot on south wall of MICE Hall at intersection with MICE Control Room

11/Jul/2011 00:26:46

Map contours: BMOD

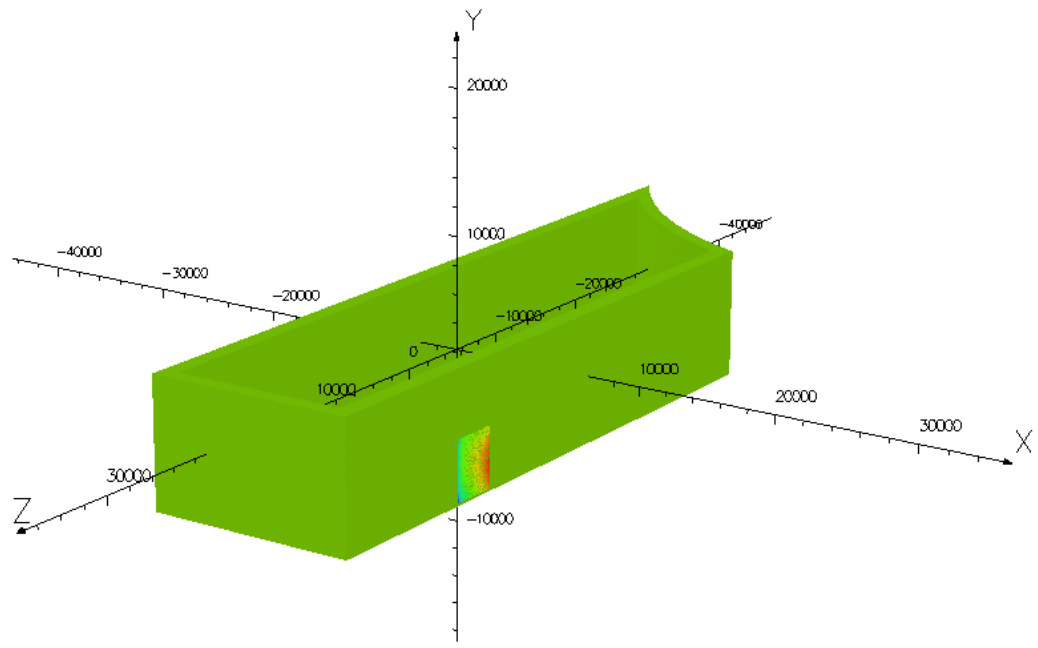
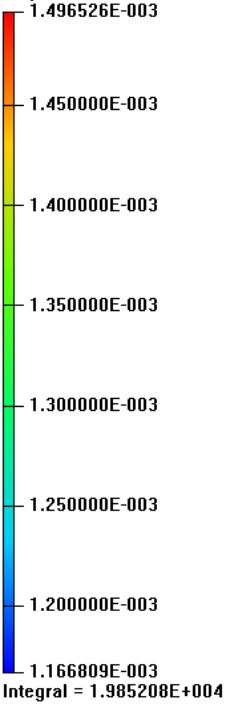

MICE CONTROL ROOM

UNITS	
Length	mm
Magn Flux Density	T
Magn Field	A m <sup>-1</sup>
Magn Scalar Pot	A
Magn Vector Pot	Wb m <sup>-1</sup>
Elec Flux Density	C m <sup>-2</sup>
Elec Field	V m <sup>-1</sup>
Conductivity	S mm <sup>-1</sup>
Current Density	A mm <sup>-2</sup>
Power	W
Force	N
Energy	J
Mass	kg

**MODEL DATA**  
model\_xt25c6s240b42.op3  
TOSCA Magnetostatic  
Nonlinear materials  
Simulation No 1 of 1  
3341264 elements  
2319728 nodes  
18 conductors  
Nodally interpolated fields  
Activated in global coordinates

**Field Point Local Coordinates**  
Local = Global

FIELD EVALUATIONS		
Cartesian (nodal)	100x100	Cartesian
x=6106.0	y=-2185.0 to 1975.0	z=9541.0 to 6096.0





# Phase VI, Solenoid mode, 240MeV/c Beta 42

## Field contour plot in XY plane at Cooling Channel centre (Z=0) (viewed from upstream)

11/Jul/2011 00:24:28

XY plane at Z=0 50 gauss contour in red - 20 gauss contour in orange - 10 gauss contour in mag

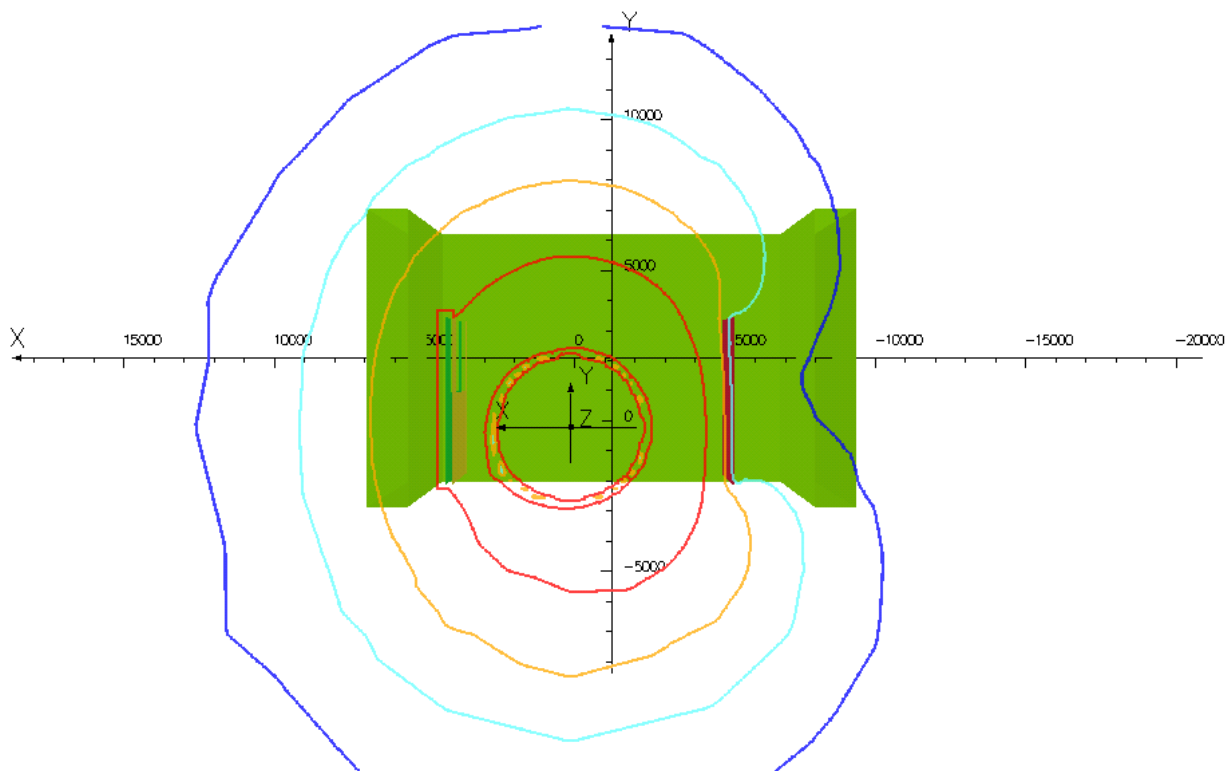
**UNITS**

Length	mm
Magn Flux Density	T
Magn Field	A m <sup>-1</sup>
Magn Scalar Pot	A
Magn Vector Pot	Wb m <sup>-1</sup>
Elec Flux Density	C m <sup>-2</sup>
Elec Field	V m <sup>-1</sup>
Conductivity	S mm <sup>-1</sup>
Current Density	A mm <sup>-2</sup>
Power	W
Force	N
Energy	J
Mass	kg

**MODEL DATA**

model\_xt25c6s240b42.op3  
TOSCA Magnetostatic  
Nonlinear materials  
Simulation No 1 of 1  
3341264 elements  
2319728 nodes  
18 conductors  
Nodally interpolated fields  
Activated in global coordinates

**Field Point Local Coordinates**

Local = Global

**FIELD EVALUATIONS**

Cartesian	CARTESIAN	100x100	Cartesian
(nodal)			
	x=-12000.0 to		y=-12000.0 to
	12000.0		12000.0
			z=0.0

Opera





# Phase VI, Solenoid mode, 240MeV/c Beta 42

## Field contour plot in ZX plane through beam axis (Y=0)

(viewed from above)

11/Jul/2011 00:24:48

XY plane at Z=0 50 gauss contour in red - 20 gauss contour in orange - 10 gauss contour in mag

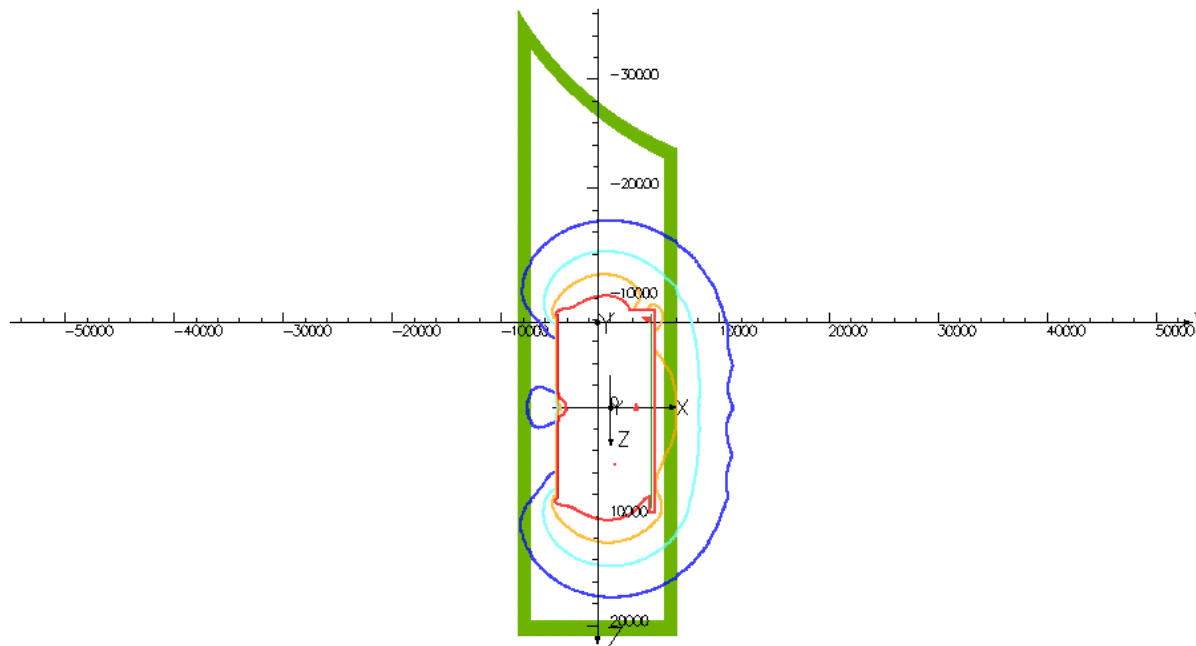
**UNITS**

Length	mm
Magn Flux Density	T
Magn Field	A m <sup>-1</sup>
Magn Scalar Pot	A
Magn Vector Pot	Wb m <sup>-1</sup>
Elec Flux Density	C m <sup>-2</sup>
Elec Field	V m <sup>-1</sup>
Conductivity	S mm <sup>-1</sup>
Current Density	A mm <sup>-2</sup>
Power	W
Force	N
Energy	J
Mass	kg

**MODEL DATA**

model\_xt25c6s240b42.op3  
TOSCA Magnetostatic  
Nonlinear materials  
Simulation No 1 of 1  
3341264 elements  
2319728 nodes  
18 conductors  
Nodally interpolated fields  
Activated in global coordinates

**Field Point Local Coordinates**

Local = Global

**FIELD EVALUATIONS**

Cartesian (nodal)	CARTESIAN	100x100 Cartesian
	x=-12000.0 to 12000.0	y=0.0 z=-18000.0 to 18000.0

Opera





# Phase VI, Solenoid mode, 240MeV/c Beta 42

## Field contour plot in ZY plane through beam axis (X=0) (viewed from north side)

11/Jul/2011 00:24:38

XY plane at Z=0 50 gauss contour in red - 20 gauss contour in orange - 10 gauss contour in mag

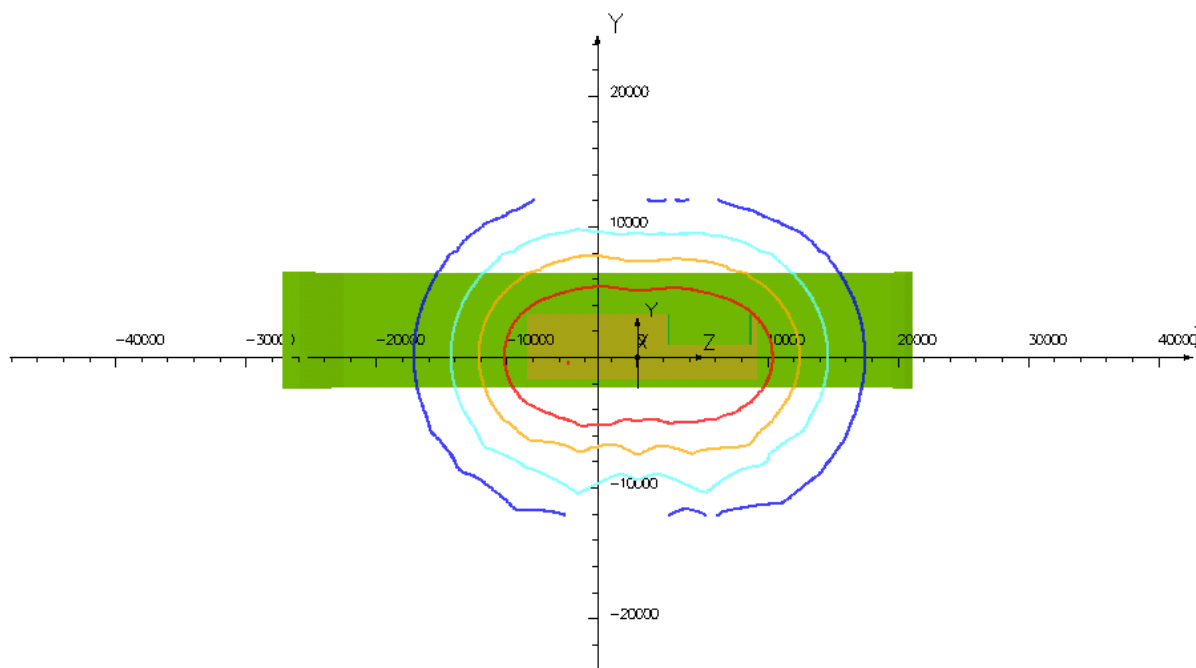
**UNITS**

Length	mm
Magn Flux Density	T
Magn Field	A m <sup>-1</sup>
Magn Scalar Pot	A
Magn Vector Pot	Wb m <sup>-1</sup>
Elec Flux Density	C m <sup>-2</sup>
Elec Field	V m <sup>-1</sup>
Conductivity	S mm <sup>-1</sup>
Current Density	A mm <sup>-2</sup>
Power	W
Force	N
Energy	J
Mass	kg

**MODEL DATA**

model\_xt25c6s240b42.op3  
TOSCA Magnetostatic  
Nonlinear materials  
Simulation No 1 of 1  
3341264 elements  
2319728 nodes  
18 conductors  
Nodally interpolated fields  
Activated in global coordinates

**Field Point Local Coordinates**

Local = Global

**FIELD EVALUATIONS**

Cartesian (nodal)	CARTESIAN 100x100	Cartesian
x=0.0	y=-12000.0 to 12000.0	z=-18000.0 to 18000.0

Opera



# Phase VI, Solenoid mode, 240MeV/c Beta 42

## Zone map of field in ZX plane through beam axis (Y=1684mm) (viewed from above) – complete map

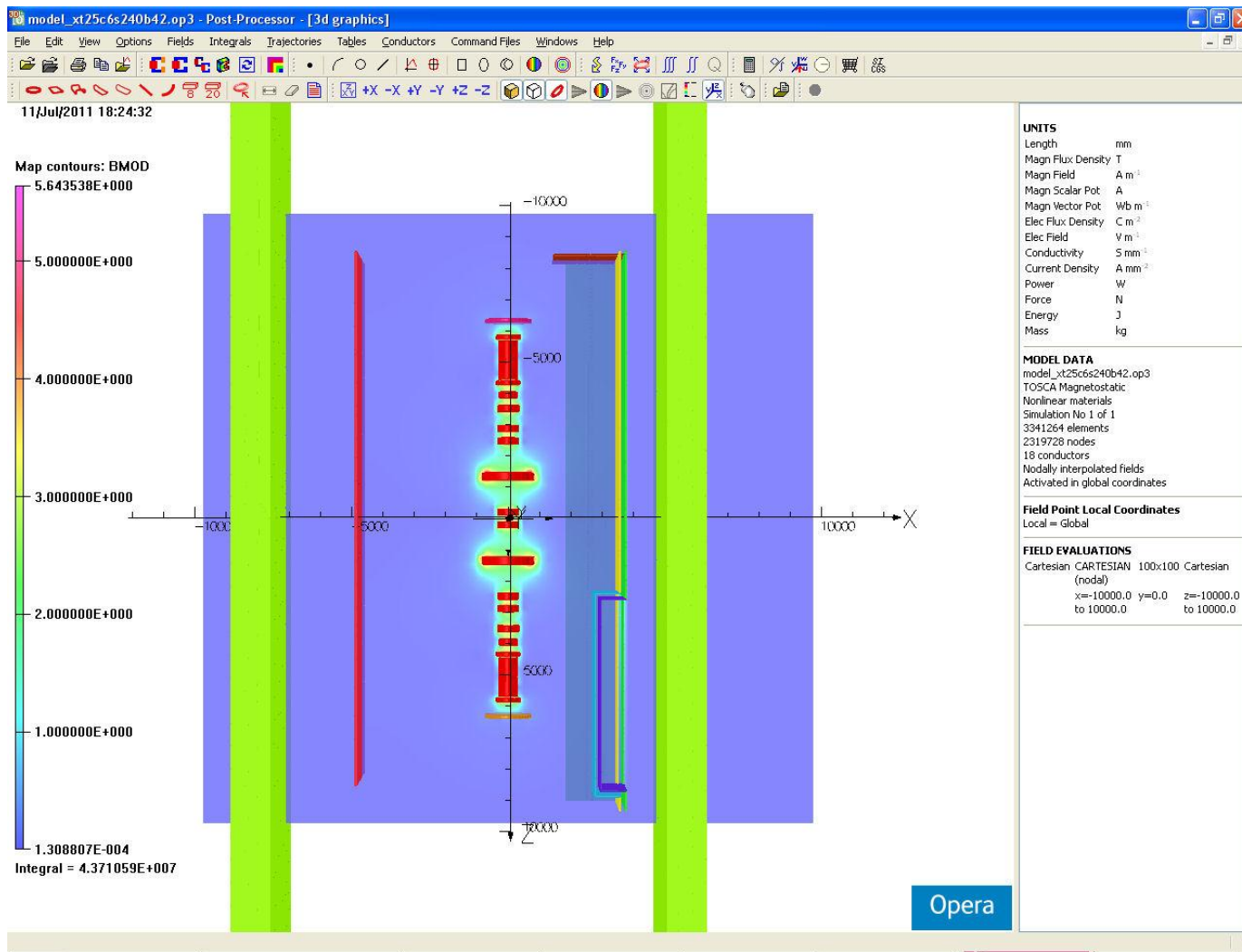

# Phase VI, Solenoid mode, 240MeV/c Beta 42

## Zone map of field in ZX plane through beam axis (Y=1684mm) (viewed from above) - 5 to 500 Gauss only

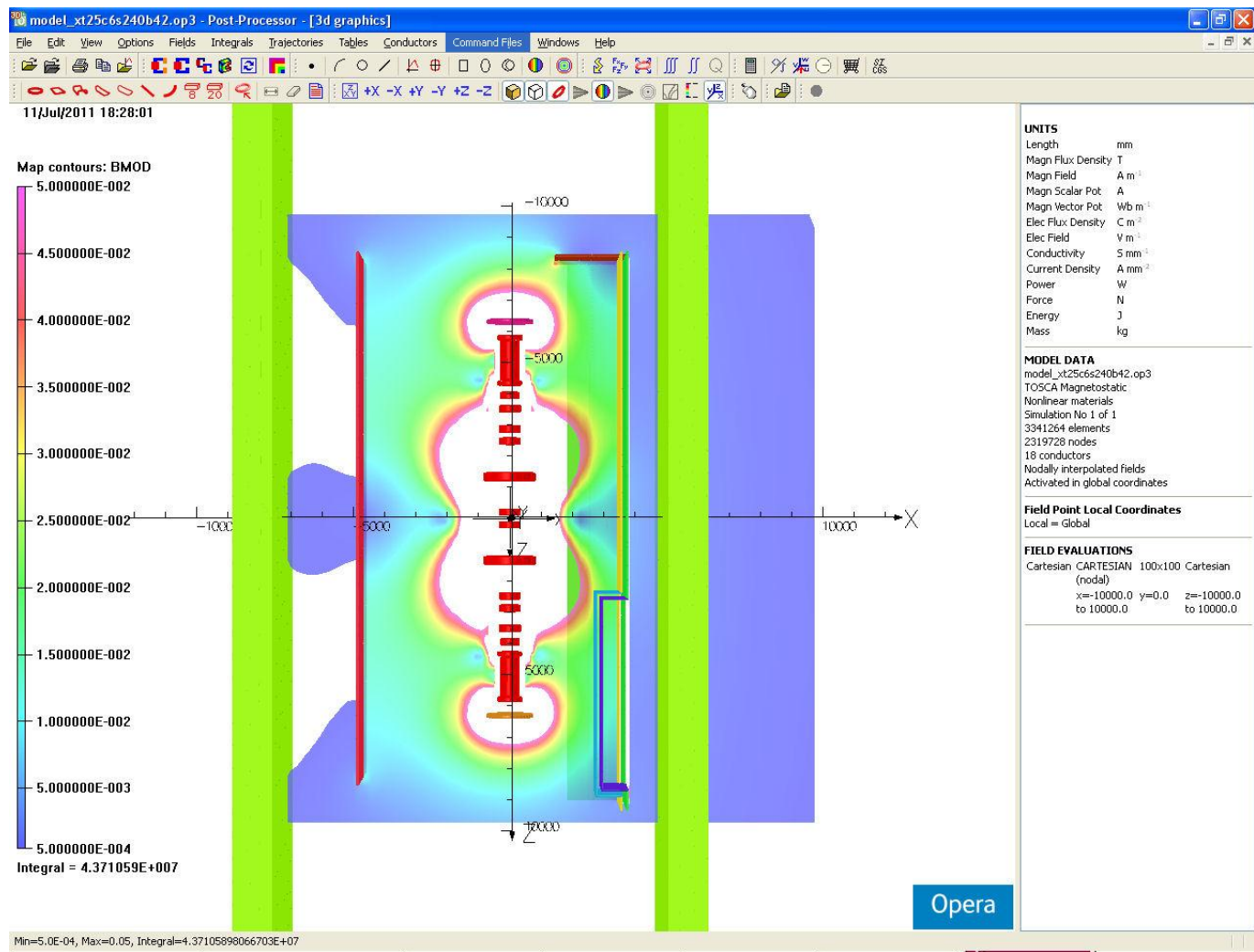



# Phase VI, Solenoid mode, 240MeV/c Beta 42

## Zone map of field in ZX plane through beam axis (Y=1684mm) (viewed from above) - 5 to 50 Gauss only

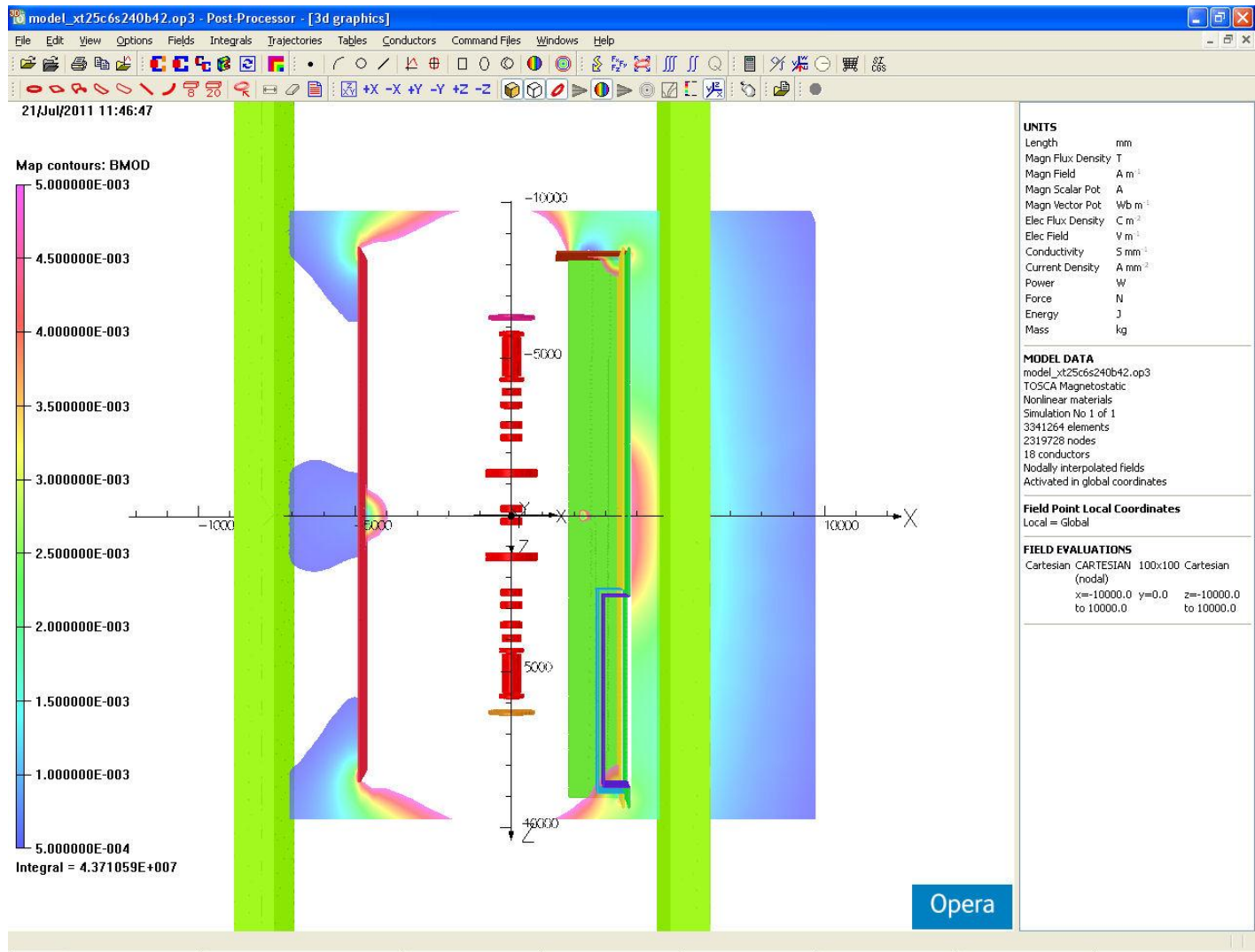



# Report from Vector Fields consultant

## · Accuracy of the Existing Model

- The Opera software uses methods that allow the fields from coils and iron to be separately calculated (reduced potentials)
- The coil fields are calculated to very high accuracy by integration
- The iron fields are calculated using a finite element method
  - However in regions where the coil and iron fields cancel, this approach tends to amplify the errors in the total field.
    - This can be avoided by specifying whether a total field FE solution is required in particular regions of space.
  - The magnetic shielding in the models reduced the field in the ISIS & MICE Control Rooms from 16 mT to 1.8mT, implying 90% cancellation of the coils' fields
    - It is thus appropriate to use total field solutions in shielded areas.
    - Opera reported an expected error of 1% in its FE solution; the cancellation would increase the error in the total field to approximately 10%.
    - The models were thus modified to use the total field solutions in all regions exterior to the cylinder containing the superconducting coils.
      - »The calculated fields in the control room changed by approximately 8%, in good agreement with the program's expected error.







# Report from Vector Fields consultant

- The accuracy of Opera's finite element solution is related to the element size and the solution exhibits quadratic convergence as the finite element's linear dimensions are reduced.
  - The element size was therefore reduced in the MICE model, to establish confidence in the programs expected error calculation.
    - The results obtained using Opera agreed with the programs error predictions and behaved consistently when the models were refined.
    - The program predicts maximum fields of 1.7mT in the ISIS and 1.5mT in the MICE control rooms with the existing shielding configuration, when the shields are manufactured from annealed US1010 steel.



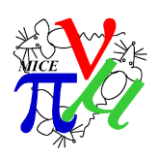

# Report from Vector Fields consultant

## • **Steel characteristics**

- Annealed US1010 steel has been frequently used to manufacture magnetic shielding for high field NMR magnets.
- The magnetic characteristics of the steel have been measured for many samples and the performance of the shields has been reliable.
- The magnetic performance of US1010 that has not been annealed is very variable.
  - The initial model for the MICE shielding has been recalculated using average properties for un-annealed US1010 steel and the fields in the ISIS and MICE control rooms increased to 2.5mT.
- Annealed US1010 properties are used for all results in the interim report, except where other steels are used to look at sensitivity.



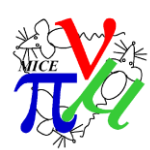

# Report from Vector Fields consultant

## Update of Results following BH Measurements at NPL

- The existing shield configuration was recalculated using the measured BH characteristics of the steel. The NPL measurements used a number of samples from the shield, the shield performance was recalculated using the poorest magnetic performance that was measured.
- The table compares the original results using SLACs measured US1010 annealed steel properties and the recalculated results using the worst properties measured by NPL.

<b>Model 0</b>	<b>Total Steel Mass (Tonnes)</b>	<b>ISIS control room Bpeak (mT)</b>	<b>MICE control room Bpeak (mT)</b>
SLAC US1010	113.8	1.7	1.5
NPL measured	113.8	1.75	1.5





# Report from Vector Fields consultant

## Options for Improving MICE magnetic Shielding

- The initial configuration of shields shows some saturation of the steel in the Control room shielding walls and floor plate.
  - A calculation using a fixed high permeability for the steel provides an easy way to check the maximum efficiency of a shielding configuration.
  - This calculation showed that if the shielding walls were increased in thickness so that the flux density in the steel was below 1T, the maximum field in the ISIS control room would be 0.47mT and in the MICE control room 0.46T.
  - The constant permeability result also gives an immediate indication of the positions where increased shield thickness is required.
- NB: Increasing the shielding plate thickness is an option, but the safety margin is small.





# Report from Vector Fields consultant

- **Increased shielding plate thickness and/or additional shielding plates**
  - These results indicate the scale of the increases in thickness needed to improve the shielding performance.
  - Additional shielding plates were added close to the coils, as shown in the figure
  - The maximum fields in the ISIS and MICE control rooms for various shielding configurations is shown in the table, together with the mass of steel compared to the existing magnetic shielding.
    - Model 0 – the existing magnetic shielding plates
    - Model 3 – increased thickness of existing shield plates
    - Model 8 – existing plates plus new close in shield plates
    - Model 10 – increased thickness of existing plus new close in shield plates

<b>Model</b>	<b>Total Steel Mass (Tonnes)</b>	<b>Change in mass of Model 0 (Tonnes)</b>	<b>ISIS control room Bpeak (mT)</b>	<b>MICE control room Bpeak (mT)</b>
Model 0	113.8	0	1.7	1.5
Model 3	123.9	10.1	0.98	0.96
Model 7	139.4	25.6	1.10	0.86
Model 10	147.0	33.2	0.69	0.71





# Report from Vector Fields consultant

## • Review of shield performance

- The results show that to achieve the same improvement in shielding, increasing the thickness of the control room floor and wall plates requires less steel than is required by the close in shields (compare Model 3 and Model 8 which have similar peak fields in the control rooms).
- The improvement in shielding is localised by increasing the existing floor and wall plate thickness close to the control room, whereas the close in shield improves the shielding in all directions.
- A single sided close in shield was not considered, because it creates a sideways force on the coils of 5 Tonnes.





# Report from Vector Fields consultant

## General Comments

- The distribution of the stray field in the control rooms was very similar for all the configurations studied, the simple approach of comparing the peak fields in the control room is therefore representative of the shielding improvement.
- The close in shield plates have only been added at the side of the coils because it would be difficult to add plates at the top and bottom. The plates have to be positioned approximately 1.7M from the beam line and at this distance the side plates only become effective at shielding the ISIS control room if they extend 2 Metres above and below the beamline. There is a large force between the coils and the close in shields; the shields must therefore be symmetrically positioned so that the force on the coils is balanced.
- In the simulations, the lowest peak field achieved in the ISIS control room was 0.69mT and in the MICE control room 0.71 mT. This was achieved by adding an extra 33 Tonnes of steel (19 Tonnes in the new close in shields and 14 Tonnes added to the existing structure).





# Report from Vector Fields consultant

4/Feb/2011 16:01:30

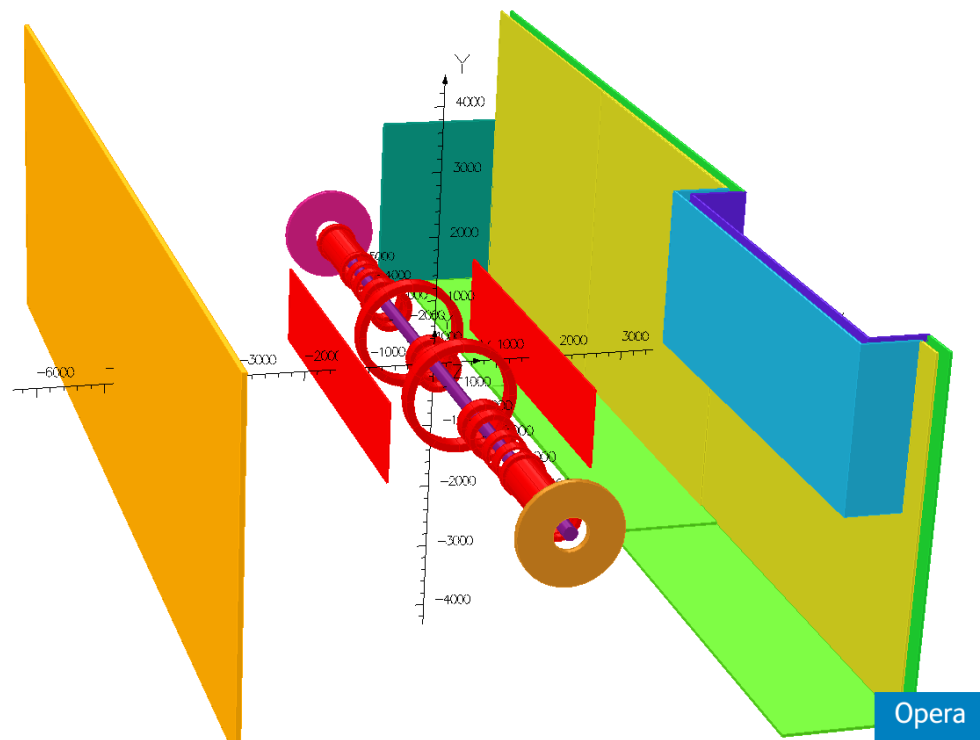





# Report from Vector Fields consultant

## • Is there a Practical Solution?

- With the constraints imposed by the existing configuration of the MICE hall it will be difficult to achieve less than 0.5mT in the ISIS and MICE control rooms when MICE is operated in the mode that gives the highest stray field.
- Adding an extra 10 Tonnes of steel to the existing steel walls would reduce the fields in the control rooms to below 1mT. To reach 0.5mT will require of the order of 50 Tonnes of additional steel added to the existing steel wall and floor plates
  - This is not a practical solution
- Fitting a shielding box around the control rooms hasn't been considered.
  - This type of shielding is not efficient, but it might be the only way of reliably reducing the field below 0.5mT.
  - However it's likely to be extremely difficult to construct this shielding.
- The most practical solution is to identify under which conditions the magnetic field will exceed 5 Gauss beyond the MICE Hall boundary, and seek permission to operate the MICE Cooling Channel magnets in these conditions with Controlled Access to areas such as the ISIS & MICE Control Rooms.





# Effect of Stray Magnetic Field from Cooling Channel Magnets on MICE Infrastructure

- **MICE infrastructure components affected by stray magnetic field**
  - All components within the magnetic shielding walls (and slightly beyond) (see field plots) will be subject to very high magnetic fields
    - **There is no place where the field will be less than 50 Gauss**
    - **Most of the region will experience fields in excess of 500 Gauss**
  - The stray field will affect numerous infrastructure components, particularly:
    - Turbo-pumps (fields > 5 Gauss)
    - Rotary or scroll pumps
    - Relays, circuit-breakers, electro-magnetic valves
    - Transformers
    - Cryo-cooler heads and their compressors
    - Computer hard-disks
    - Vacuum gauges
  - It has been confirmed that **sensitive components can be individually protected** with single-layer Mumetal screens, **but at a cost** (eg - each of the 31 cryo-cooler compressors will need a protective screen costing ~£1500 => £47k)
    - These screens can be designed and produced within 7 weeks for any items that are overlooked
  - **It is important to keep sensitive components as far from the stray fields as practical, to reduce the risk of malfunction and the consequential cost of remedial protective screening**





# Conclusions

- The MICE magnetic shielding walls are effective in shielding the ISIS and MICE Control Rooms from stray magnetic field in all MICE Steps and cases, except for the most energetic cases within Steps 5 and 6.
- MICE is in the process of seeking approval from ISIS and RAL SHE Group to operate the MICE Cooling Channel magnets in these conditions with restricted access to areas such as the ISIS & MICE Control Rooms by means of signs warning of stray magnetic fields
  - But there is no guarantee that ISIS and RAL SHE Group will agree to this request
- It is envisaged that the strength and extent of the stray magnetic fields predicted by the analysis will be checked by taking magnetic field measurements in key areas during running of the MICE operations, as confirmation.
- Numerous MICE infrastructure components could potentially be seriously affected by the stray magnetic fields, but there are ways to protect them, if they cannot be relocated, by means of Mumetal screening – but at a significant cost

