

Technical Developments Two Beam Module

A. Karlov (DUBNA, JINR)

03-Nov-2011

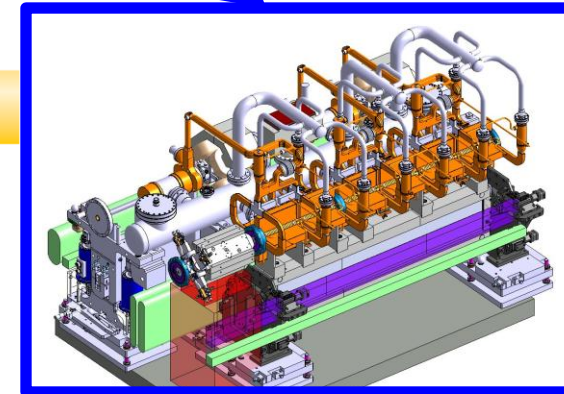
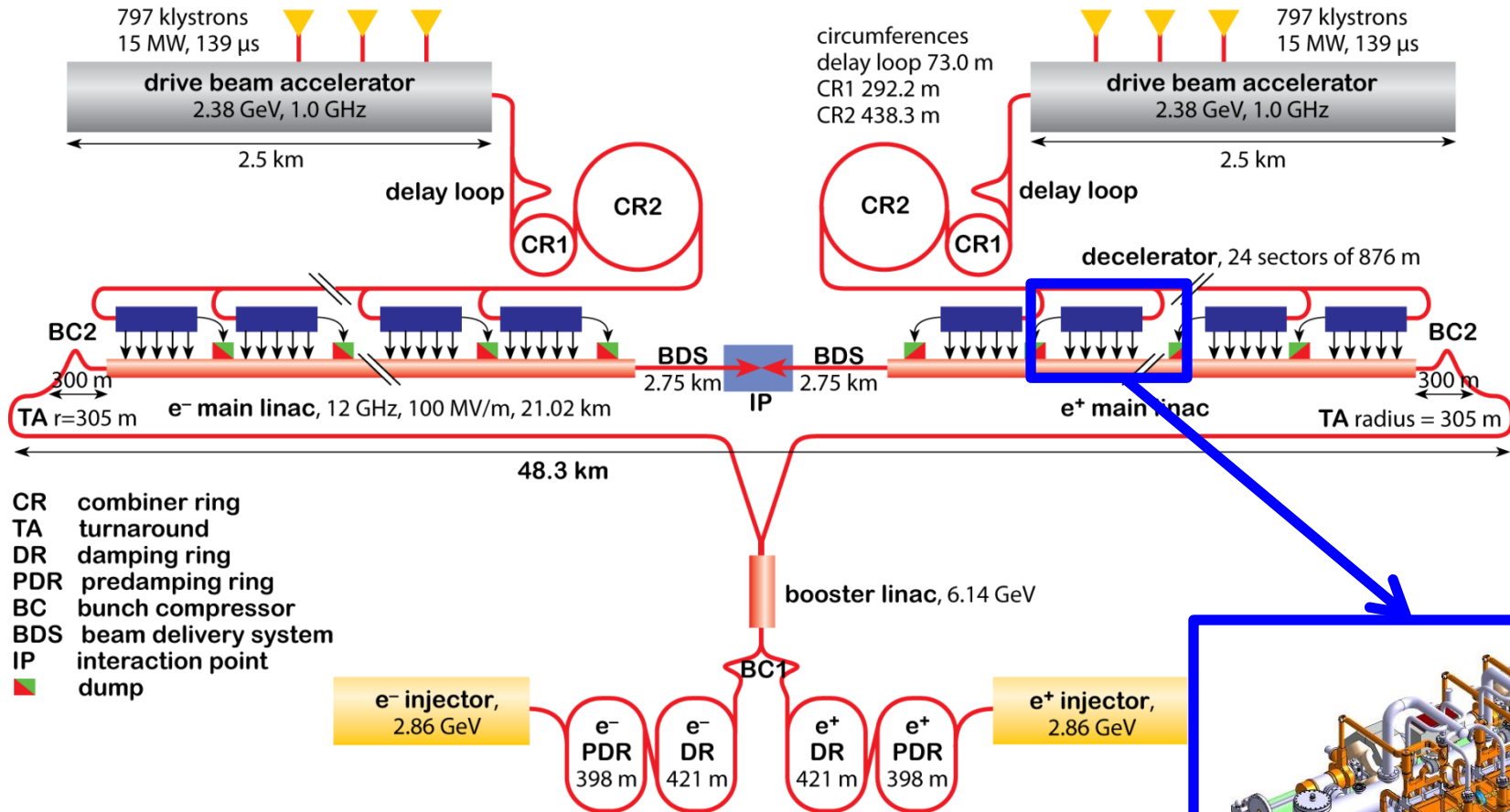

Two Beam Module Integration Layout

CLIC is based on the two-beam acceleration method in which the RF power for sections of the main linac is extracted from a second, low-energy, high-intensity electron beam running parallel to the main linac (drive beam). The drive-beam regularly powers two Accelerating Structures (AS) from one Power Extraction and Transfer Structure (PETS). Each module might contain up to four PETS, feeding two AS each, and two drive-beam quadrupoles, as a very dense lattice is required for the low-energy drive beam.

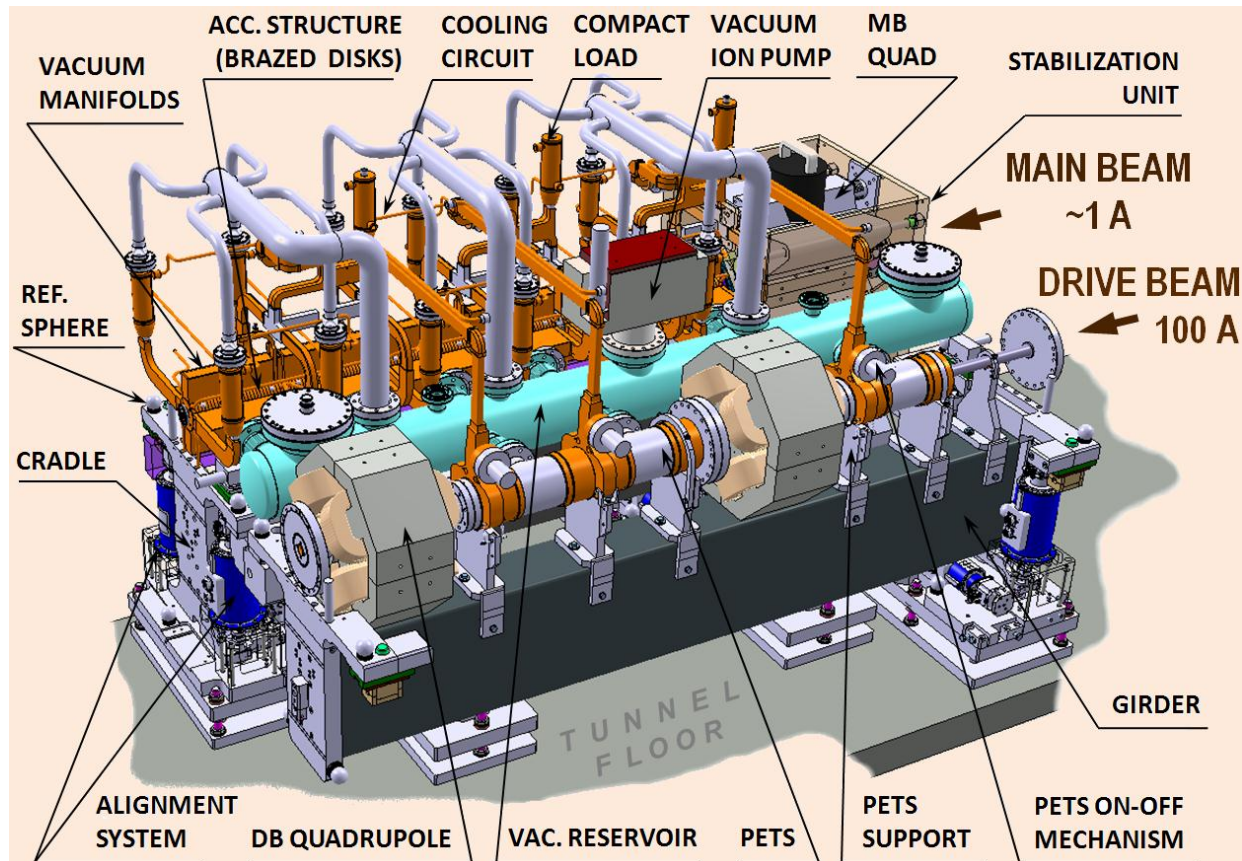

- Engineering design of RF structures;
- Engineering design of sub-units, i.e. “BPM - Drive Beam magnet vacuum chamber - PETS interconnection”
- Definition of boundary conditions for alignment / stabilization systems;
- Engineering design of cooling / supporting system
- Integration of different systems components into module layout;
- Engineering design of assembly toolings;
- Procurement of corresponding components for test modules;
- Definition and implementation of Quality Assurance system;
- ...

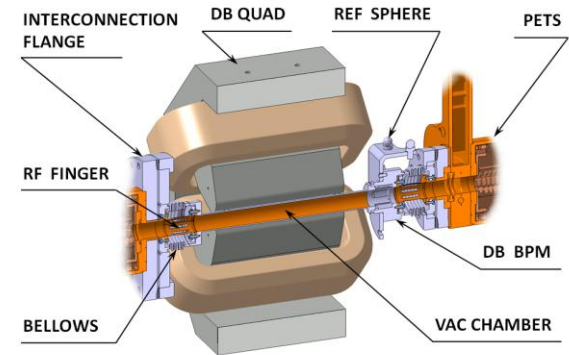

“BPM – DB Q vacuum chamber – PETS” unit

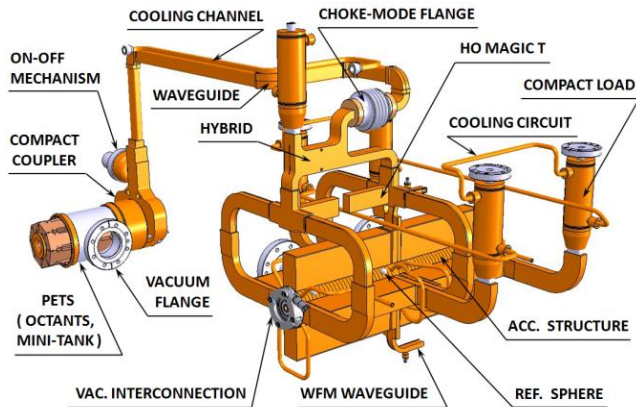

RF system components design & integration

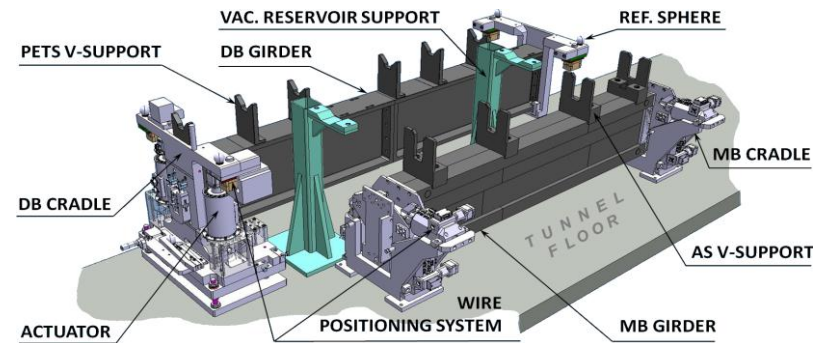

Supporting & Alignment systems