













# Particle Detectors 2/2





Werner Riegler, CERN, [werner.riegler@cern.ch](mailto:werner.riegler@cern.ch)

# The 'Standard Model'

matter particles

gauge particles

	1st gen.	2nd gen.	3rd gen.
Q U A R K	 <i>u</i> <i>up</i>	 <i>c</i> <i>charm</i>	 <i>t</i> <i>top</i>
	 <i>d</i> <i>down</i>	 <i>s</i> <i>strange</i>	 <i>b</i> <i>bottom</i>
L E P T O N	 <i><math>\nu_e</math></i> <i>e neutrino</i>	 <i><math>\nu_\mu</math></i> <i><math>\mu</math> neutrino</i>	 <i><math>\nu_\tau</math></i> <i><math>\tau</math> neutrino</i>
	 <i>e</i> <i>electron</i>	 <i><math>\mu</math></i> <i>muon</i>	 <i><math>\tau</math></i> <i>tau</i>

Strong Force  <i>g</i> <i>Gluon</i>
Electro-Magnetic Force  <i><math>\gamma</math></i> <i>photon</i>
Weak Force    <i>W<sup>+</sup></i> <i>W<sup>-</sup></i> <i>Z</i> <i>W bosons</i> <i>Z boson</i>

scalar particle(s)

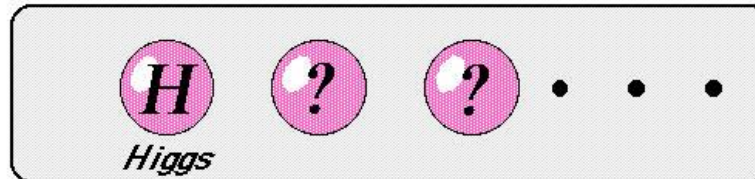

# The 'Standard Model'

$$\begin{aligned}
 L_{GSW} = & L_0 + L_H + \sum_l \left\{ \frac{g}{2} \bar{L}_l \gamma_\mu \bar{\tau} L_l \bar{A}^\mu + g' \left[ \bar{R}_l \gamma_\mu R_l + \frac{1}{2} \bar{L}_l \gamma_\mu L_l \right] B^\mu \right\} + \\
 & + \frac{g}{2} \sum_q \bar{L}_q \gamma_\mu \bar{\tau} L_q \bar{A}^\mu + \\
 & + g' \left\{ \frac{1}{6} \sum_q \left[ \bar{L}_q \gamma_\mu L_q + 4 \bar{R}_q \gamma_\mu R_q \right] + \frac{1}{3} \sum_{q'} \bar{R}_{q'} \gamma_\mu R_{q'} \right\} B^\mu
 \end{aligned}$$

$$\begin{aligned}
 L_H = & \frac{1}{2} (\partial_\mu H)^2 - m_H^2 H^2 - h \lambda H^3 - \frac{h}{4} H^4 + \\
 & + \frac{g^2}{4} (W_\mu^+ W^\mu + \frac{1}{2 \cos^2 \theta_W} Z_\mu Z^\mu) (\lambda^2 + 2 \lambda H + H^2) + \\
 & + \sum_{l,q,q'} \left( \frac{m_l}{\lambda} \bar{l} l + \frac{m_q}{\lambda} \bar{q} q + \frac{m_{q'}}{\lambda} \bar{q}' q' \right) H
 \end{aligned}$$

Over the last century  
this 'Standard Model' of  
Fundamental Physics was discovered  
by studying

Radioactivity

Cosmic Rays

Particle Collisions (Accelerators)

A large variety of Detectors and  
experimental techniques have been  
developed during this time.

# Scales

$$E = ma^2$$

$$E = mb^2$$

$$E = mc^2 \leftarrow \text{Energy} \hat{=} \text{Mass}$$

⋮

$$m(\text{electron}) = 9.1 \cdot 10^{-31} \text{ kg}$$

$$m_e c^2 = 8.19 \cdot 10^{-14} \text{ J}$$

$$= 510\,999 \text{ Electron Volt (eV)}$$

$$= 0.511 \text{ MeV}$$

$$1 \text{ Electron Volt} = e_0 \cdot 1\text{V} = 1.603 \cdot 10^{-19} \text{ J}$$

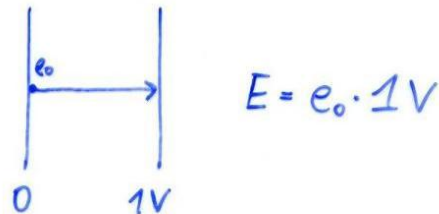

1 Electron Volt - Energy an Electron gains as it traverses a Potential Difference of 1V

# Build your own Accelerator

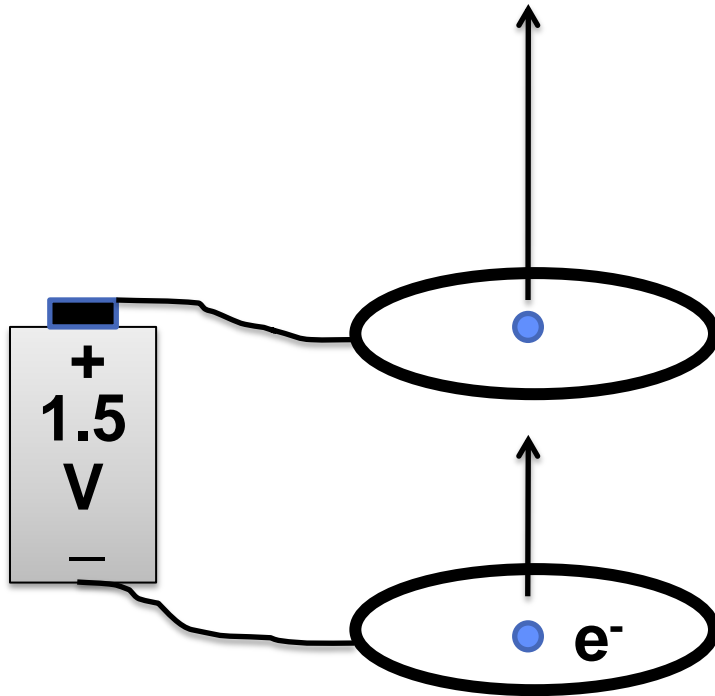

$$E_{\text{kin}} = 1.5\text{eV} =$$

$$2\,615\,596\text{ km/h}$$

## Scales

8

Visible Light:

$\lambda = 500 \text{ nm}$ ,  $h\nu \approx 2.5 \text{ eV}$

Excited States in Atoms:

1-100 keV "X-Rays"

Nuclear Physics:

1-50 MeV

Particle Physics:

1-1000 GeV (LHC 14 TeV)

Highest Measured Energy:

$10^{20} \text{ eV}$  (Cosmic Rays)

# Basics

9

## Lorentz Boost:

$$\mu^- \rightarrow e^- + \bar{\nu}_e + \gamma_\mu \quad \tau = 2.2 \cdot 10^{-6} \text{ s}$$

E.g. Produced by Cosmic Rays (p, He, Li ...)  
colliding with air in the upper atmosphere  $\sim 10 \text{ km}$

$$s = v \cdot \tau \sim c \cdot \tau = 660 \text{ m}$$

But we see Muons here on Earth

$$E_\mu \sim 2 \text{ GeV}, m_\mu c^2 = 105 \text{ MeV} \rightarrow \gamma \sim 19$$

$$\text{Relativity: } \bar{\tau} = \gamma \cdot \tau$$

$$s = c \cdot \bar{\tau} = 12.5 \text{ km} \rightarrow \text{Earth}$$

$$\text{Pions: } \pi^+, \pi^- \quad \tau \sim 2.6 \cdot 10^{-8} \text{ s}, m_\pi c^2 = 135 \text{ MeV}$$

$$2 \text{ GeV} \rightarrow s = 115 \text{ m}$$

Pions were discovered in Emulsions exposed  
to Cosmic Rays on high mountains.



$\eta, W^\pm, Z^0, g, e, \mu, \tau, \nu_e, \nu_\mu, \nu_\tau, \pi^\pm, \pi^0, \eta, f_0(660), g(890),$   
 $\omega(782), \eta'(958), f_0(980), a_0(980), \phi(1020), h_1(1170), b_1(1235),$   
 $a_1(1260), f_2(1270), f_1(1285), \eta(1295), \pi(1300), a_2(1320),$   
 $f_0(1370), f_1(1420), \omega(1420), \eta(1440), a_0(1450), g(1450),$   
 $f_0(1500), f_2'(1525), \omega(1650), \omega_3(1670), \pi_2(1670), \phi(1680),$   
 $g_3(1690), g(1700), f_0(1710), \pi(1800), \phi_3(1850), f_2(2010),$   
 $a_4(2040), f_4(2050), f_2(2300), f_2(2340), K^\pm, K^0, K_S^0, K_L^0, K^*(892),$   
 $K_1(1270), K_1(1400), K^*(1410), K_D^*(1430), K_2^*(1430), K^*(1680),$   
 $K_2(1770), K_3^*(1780), K_2(1820), K_4^*(2045), D^\pm, D^0, D^*(2007)^0,$   
 $D^*(2010)^\pm, D_1(2420)^0, D_2^*(2460)^0, D_2^*(2460)^\pm, D_s^\pm, D_s^{*\pm},$   
 $D_{s1}(2536)^\pm, D_{s3}(2573)^\pm, B^\pm, B^0, B^*, B_S^0, B_c^\pm, \eta_c(1S), J/\psi(1S),$   
 $\chi_{c0}(1P), \chi_{c1}(1P), \chi_{c2}(1P), \psi(2S), \psi(3770), \psi(4040), \psi(4160),$   
 $\psi(4415), \Upsilon(1S), \chi_{b0}(1P), \chi_{b1}(1P), \chi_{b2}(1P), \Upsilon(2S), \chi_{b0}(2P),$   
 $\chi_{b2}(2P), T(3S), T(4S), T(10860), T(11020), p, n, N(1440),$   
 $N(1520), N(1535), N(1650), N(1675), N(1680), N(1700), N(1710),$   
 $N(1720), N(2190), N(2220), N(2250), N(2600), \Delta(1232), \Delta(1600),$   
 $\Delta(1620), \Delta(1700), \Delta(1905), \Delta(1910), \Delta(1920), \Delta(1930), \Delta(1950),$   
 $\Delta(2420), \Lambda, \Lambda(1405), \Lambda(1520), \Lambda(1600), \Lambda(1670), \Lambda(1690),$   
 $\Lambda(1800), \Lambda(1810), \Lambda(1820), \Lambda(1830), \Lambda(1890), \Lambda(2100),$   
 $\Lambda(2110), \Lambda(2350), \Sigma^+, \Sigma^0, \Sigma^-, \Sigma(1385), \Sigma(1660), \Sigma(1670),$   
 $\Sigma(1750), \Sigma(1775), \Sigma(1915), \Sigma(1940), \Sigma(2030), \Sigma(2250), \Xi^0, \Xi^-,$   
 $\Xi(1530), \Xi(1690), \Xi(1820), \Xi(1950), \Xi(2030), \Omega^-, \Omega(2250)^-,$   
 $\Lambda_c^+, \Lambda_c^0, \Sigma_c(2455), \Sigma_c(2520), \Xi_c^+, \Xi_c^0, \Xi_c'^+, \Xi_c'^0, \Xi_c(2645)$   
 $\Xi_c(2780), \Xi_c(2815), \Omega_c^0, \Lambda_b^0, \Xi_b^0, \Xi_b^-, t\bar{t}$

There are many more

Particle	Mass (MeV)	Life time $\tau$ (s)	$c\tau$
$\gamma$	0	$\infty$	$\infty$
$\pi^\pm (u\bar{d}, d\bar{u})$	140	$2.6 \cdot 10^{-8}$	7.8 m
$K^\pm (u\bar{s}, \bar{u}s)$	494	$1.2 \cdot 10^{-8}$	3.7 m
$K^0 (d\bar{s}, \bar{d}s)$	497	$5.1 \cdot 10^{-8}$ $8.9 \cdot 10^{-11}$	15.5 m 2.7 cm
$D^\pm (c\bar{d}, \bar{c}d)$	1869	$1.0 \cdot 10^{-12}$	315 $\mu\text{m}$
$D^0 (c\bar{u}, \bar{c}u)$	1864	$4.1 \cdot 10^{-13}$	123 $\mu\text{m}$
$D_s^\pm (c\bar{s}, \bar{c}s)$	1969	$4.9 \cdot 10^{-13}$	147 $\mu\text{m}$
$B^\pm (u\bar{b}, \bar{u}b)$	5279	$1.7 \cdot 10^{-12}$	502 $\mu\text{m}$
$B^0 (b\bar{d}, \bar{b}d)$	5279	$1.5 \cdot 10^{-12}$	462 $\mu\text{m}$
$B_s^0 (s\bar{b}, \bar{s}b)$	5370	$1.5 \cdot 10^{-12}$	438 $\mu\text{m}$
$B_c^\pm (c\bar{b}, \bar{c}b)$	$\sim 6400$	$\sim 5 \cdot 10^{-13}$	150 $\mu\text{m}$
$p (uud)$	938.3	$> 10^{33} \text{ y}$	$\infty$
$n (udd)$	939.6	885.7 s	$2.655 \cdot 10^8 \text{ km}$
$\Lambda^0 (uds)$	1115.7	$2.6 \cdot 10^{-10}$	7.89 cm
$\Sigma^+ (uus)$	1189.4	$8.0 \cdot 10^{-11}$	2.404 cm
$\Sigma^- (dds)$	1197.4	$1.5 \cdot 10^{-10}$	4.434 cm
$\Xi^0 (uss)$	1315	$2.9 \cdot 10^{-10}$	8.71 cm
$\Xi^- (dss)$	1321	$1.6 \cdot 10^{-10}$	4.91 cm
$\Omega^- (sss)$	1672	$8.2 \cdot 10^{-11}$	2.461 cm
$\Lambda_c^+ (udc)$	2285	$\sim 2 \cdot 10^{-13}$	60 $\mu\text{m}$
$\Xi_c^+ (usc)$	2466	$4.4 \cdot 10^{-13}$	132 $\mu\text{m}$
$\Xi_c^0 (dcs)$	2472	$\sim 1 \cdot 10^{-13}$	29 $\mu\text{m}$
$\Sigma_c^0 (ssc)$	2698	$6.0 \cdot 10^{-14}$	19 $\mu\text{m}$
$\Lambda_b (uab)$	5620	$1.2 \cdot 10^{-12}$	368 $\mu\text{m}$

"Secondary Vertices"

From the 'hundreds' of Particles listed by the PDG there are only  $\sim 27$  with a life time  $c\tau > \sim 1\mu\text{m}$  i.e. they can be seen as 'tracks' in a Detector.

$\sim 13$  of the 27 have  $c\tau < 500\mu\text{m}$  i.e. only  $\sim\text{mm}$  range at GeV Energies.  
→ "short" tracks measured with Emulsions or Vertex Detectors.

From the  $\sim 14$  remaining particles

$e^\pm, \mu^\pm, \gamma, \pi^\pm, K^\pm, K^0, p^\pm, n$

are by far the most frequent ones

A particle Detector must be able to identify and measure Energy and Momenta of these 8 particles.

## Basics

Invariant Mass:

LAB:

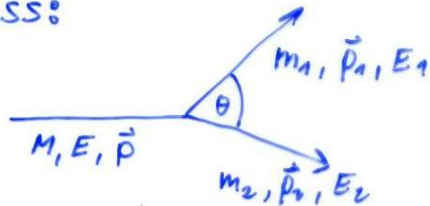

Relativity:  $\tilde{a} = \begin{pmatrix} a_0 \\ \vec{a} \end{pmatrix}$   $\tilde{b} = \begin{pmatrix} b_0 \\ \vec{b} \end{pmatrix}$   $\tilde{a} \tilde{b} = a_0 b_0 - \vec{a} \cdot \vec{b}$

$$E = mc^2 \gamma, \quad \vec{p} = m \vec{v} \gamma$$

$$\tilde{p} = \begin{pmatrix} \frac{E}{c} \\ \vec{p} \end{pmatrix}, \quad \tilde{p}_1 = \begin{pmatrix} \frac{E_1}{c} \\ \vec{p}_1 \end{pmatrix}, \quad \tilde{p}_2 = \begin{pmatrix} \frac{E_2}{c} \\ \vec{p}_2 \end{pmatrix}$$

$$\tilde{p} = \tilde{p}_1 + \tilde{p}_2 \quad \text{Energy + Momentum Conservation}$$

$$\tilde{p}^2 = (\tilde{p}_1 + \tilde{p}_2)^2 \rightarrow \tilde{p} \tilde{p} = \tilde{p}_1 \tilde{p}_1 + \tilde{p}_2 \tilde{p}_2 + 2 \tilde{p}_1 \tilde{p}_2$$

$$\underline{M^2 c^2 = m_1^2 c^2 + m_2^2 c^2 + 2 \left( \frac{E_1 E_2}{c^2} - p_1 p_2 \cos \theta \right)}$$

- Measuring Momenta and Energies OR
- Measuring Momenta and identifying Particles  
gives the Mass of the original Particle

# Momentum Measurement

Magnetic Spectrometer: A charged particle describes a circle in a magnetic field:

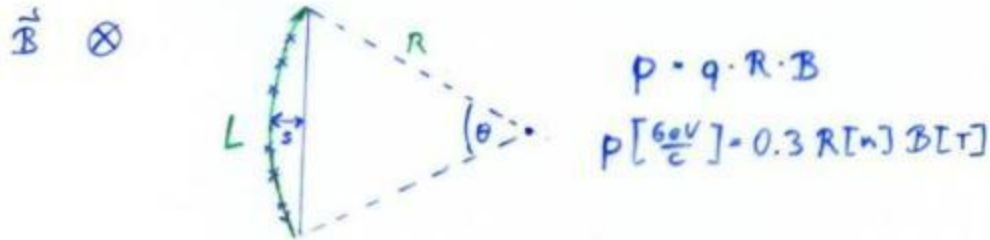

$$L = R \cdot \theta$$

$$S = R \left( 1 - \cos \frac{\theta}{2} \right) \sim R \frac{\theta^2}{8} = \frac{L^2}{8R} \rightarrow R = \frac{L^2}{8S}$$

$$\Delta p = 0.3 B \Delta R = 0.3 B \frac{L^2}{8S^2} \Delta S$$

$$\Delta S = \frac{\sigma_x}{\sqrt{N}} \quad \sigma_x \dots \text{point resolution, } N \dots \text{Measurement Points}$$

$$\frac{\Delta p}{p} = \frac{\Delta S}{S} = \frac{\sigma_x [\text{m}]}{\sqrt{N}} \cdot \frac{3.3 \cdot 8 p \left[ \frac{\text{GeV}}{c} \right]}{B [\text{T}] \cdot L^2 [\text{m}^2]}$$

E.g:  $p = 10 \frac{\text{GeV}}{c}$ ,  $B = 1 \text{T}$ ,  $L = 1 \text{m}$ ,  $\sigma_x = 200 \mu\text{m}$ ,  $N = 25$

$$\frac{\Delta p}{p} = 0.01 \rightarrow 1\%$$

Limit  $\rightarrow$  Multiple Scattering

# Multiple Scattering

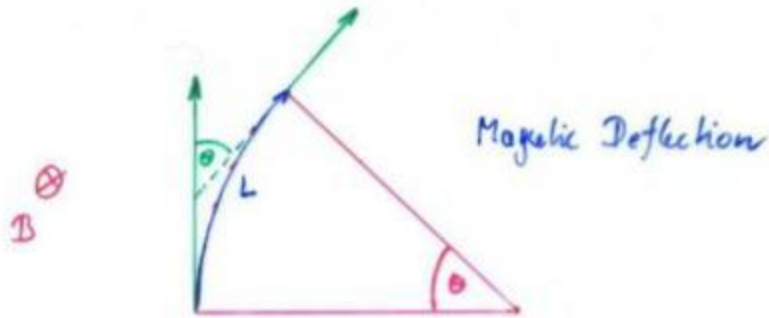

$$p \left[ \frac{\text{GeV}}{c} \right] = 0.3 R [\text{m}] B [\text{T}]$$

$$\theta = \frac{L}{R} = \frac{L}{p} \cdot 0.3 B$$

$$\frac{\Delta p}{p} = \frac{\Delta \theta}{\theta} = \frac{\theta_0}{\theta} \sim \frac{0.05}{3 B [\text{T}] L [\text{m}]} \sqrt{\frac{L}{x_0}}$$

→ Independent of  $p$

$$\frac{\Delta p}{p} \Big|_{\text{tot}} = \sqrt{\left( \frac{\Delta p}{p} \Big|_{\text{Sog}} \right)^2 + \left( \frac{\Delta p}{p} \Big|_{\text{ms}} \right)^2}$$

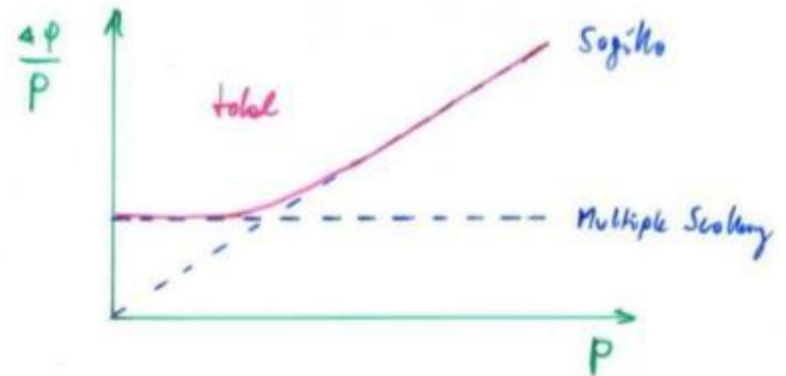

# Multiple Scattering

ATLAS Muon Spectrometer:

$N=3$ ,  $\sigma=50\mu\text{m}$ ,  $P=1\text{TeV}$ ,

$L=5\text{m}$ ,  $B=0.4\text{T}$

$\Delta p/p \sim 8\%$  for the most energetic muons at LHC

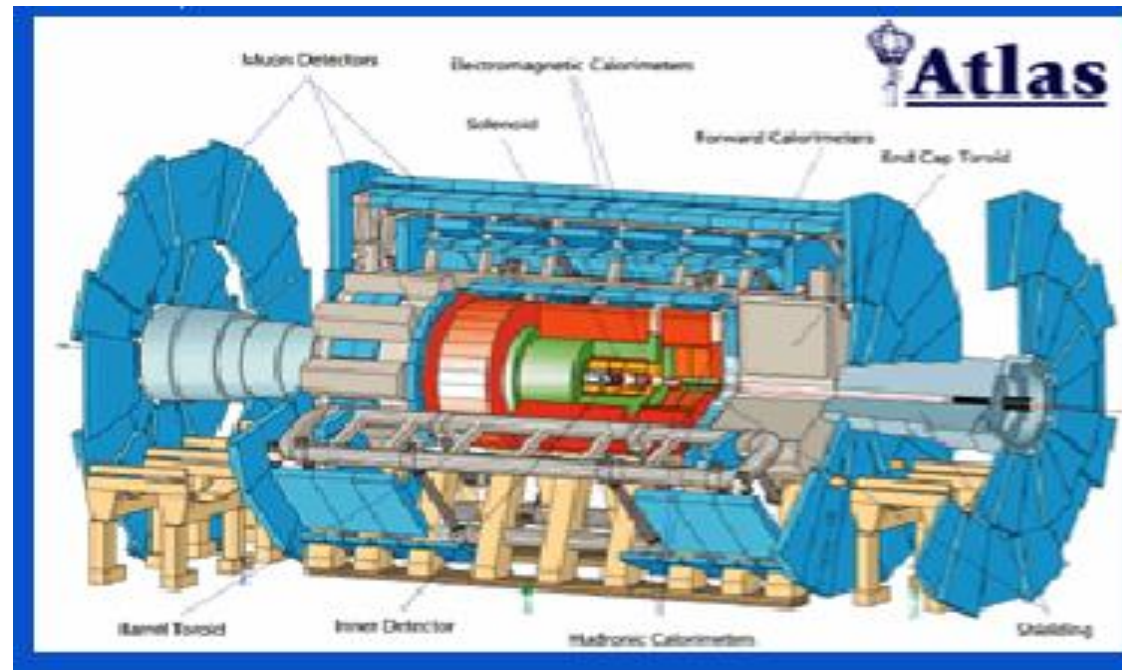
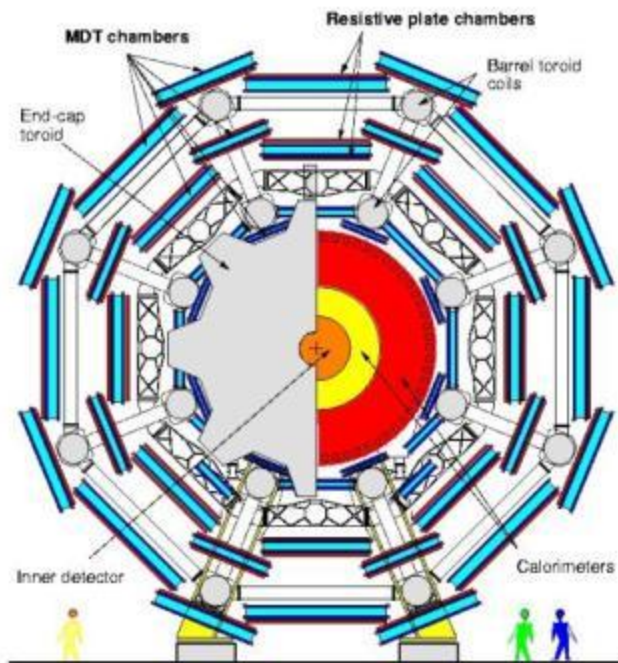

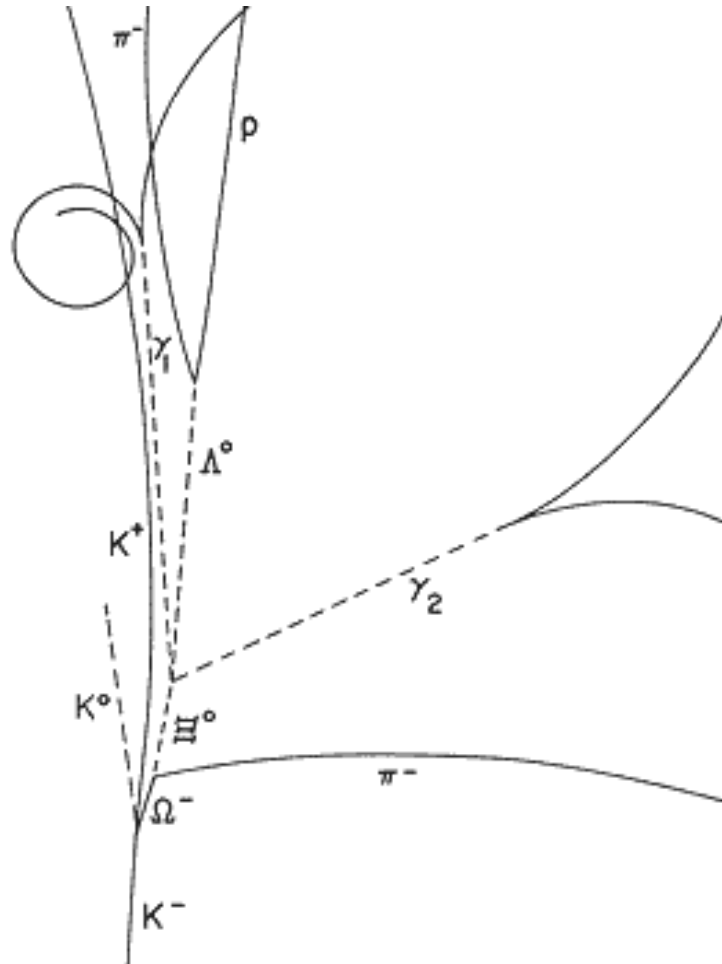
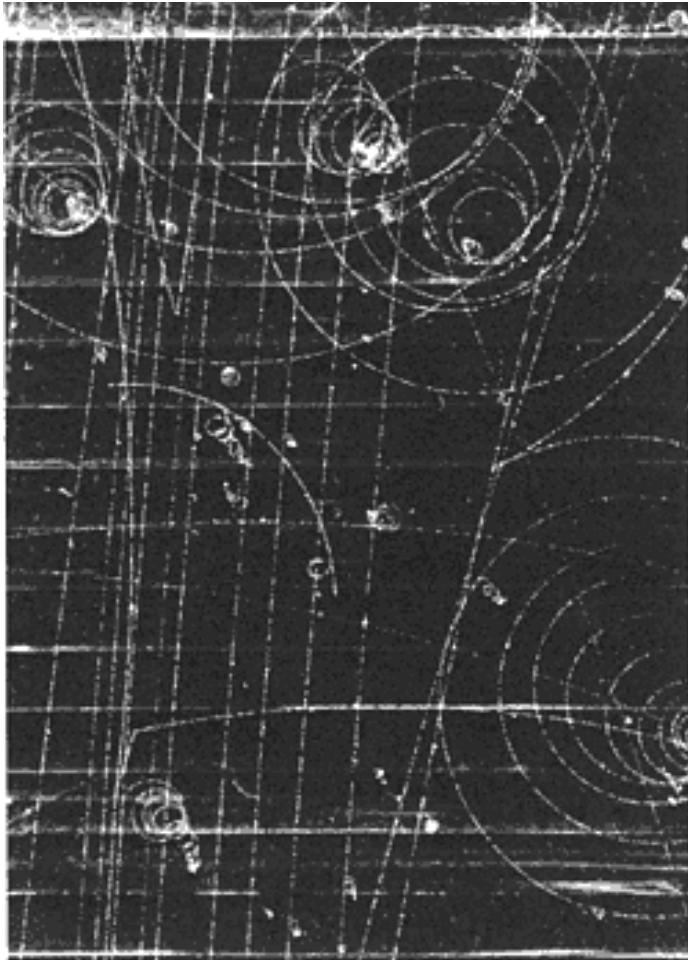



$e^\pm$	$m_e = 0.511 \text{ MeV}$	} EM
$\mu^\pm$	$m_\mu = 105.7 \text{ MeV} \sim 200 m_e$	
$\gamma$	$m_\gamma = 0, Q = 0$	
$\pi^\pm$	$m_\pi = 139.6 \text{ MeV} \sim 270 m_e$	} EM, Strong
$K^\pm$	$m_K = 493.7 \text{ MeV} \sim 1000 m_e \sim 3.5 m_\pi$	
$p^\pm$	$m_p = 938.3 \text{ MeV} \sim 2000 m_e$	
$K^0$	$m_{K^0} = 497.7 \text{ MeV} \quad Q=0$	} Strong
$n$	$m_n = 939.6 \text{ MeV} \quad Q=0$	

The Difference in Mass, Charge,

Mass, Charge, Interaction

is the key to the Identification

## Tracking:

Momentum by bending in the B-field

Secondary vertices

## Calorimeter:

Energy by absorption

## Muons:

Only particles passing through calorimeters

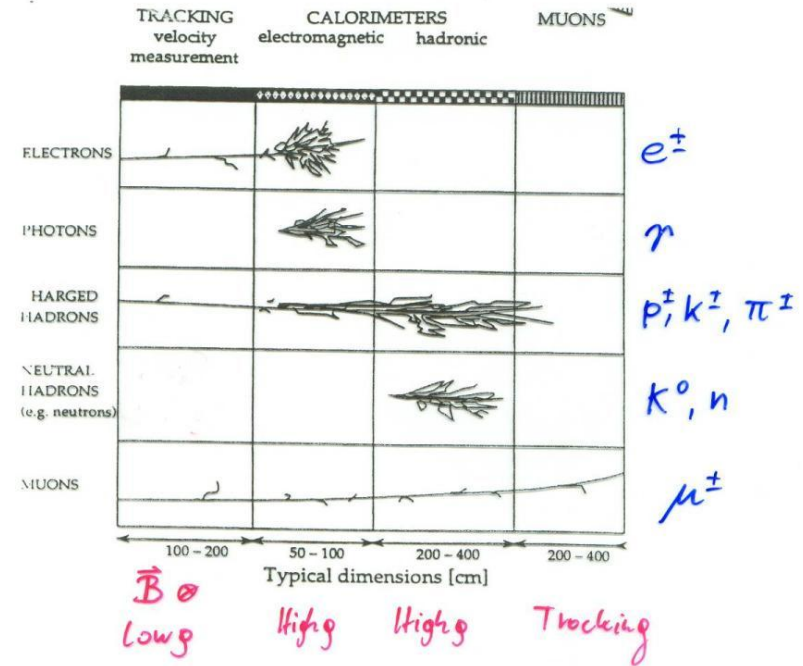

- Electrons ionize and show Bremsstrahlung due to the small mass
- Photons don't ionize but show Pair Production in high  $Z$  Material. From then on equal to  $e^\pm$
- Charged Hadrons ionize and show Hadron Shower in dense Material.
- Neutral Hadrons don't ionize and show Hadron Shower in dense Material
- Muons ionize and don't shower

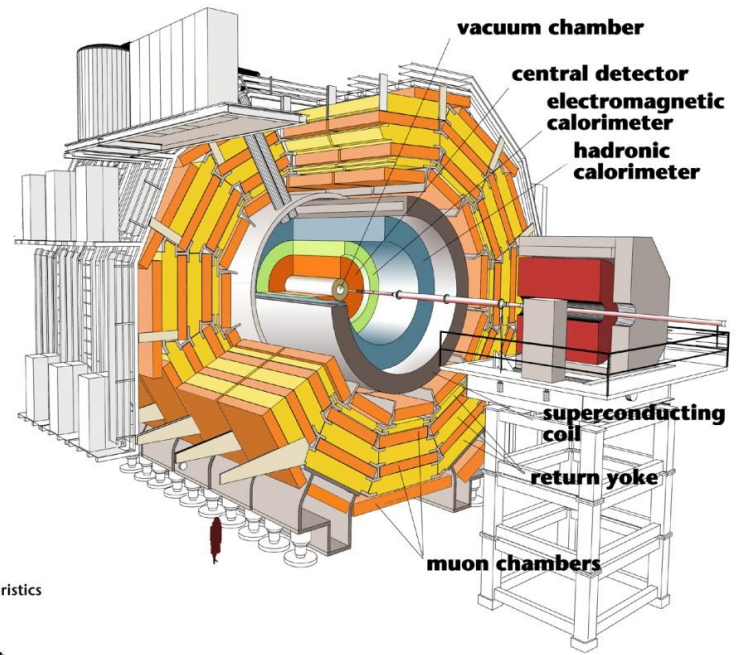
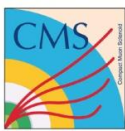
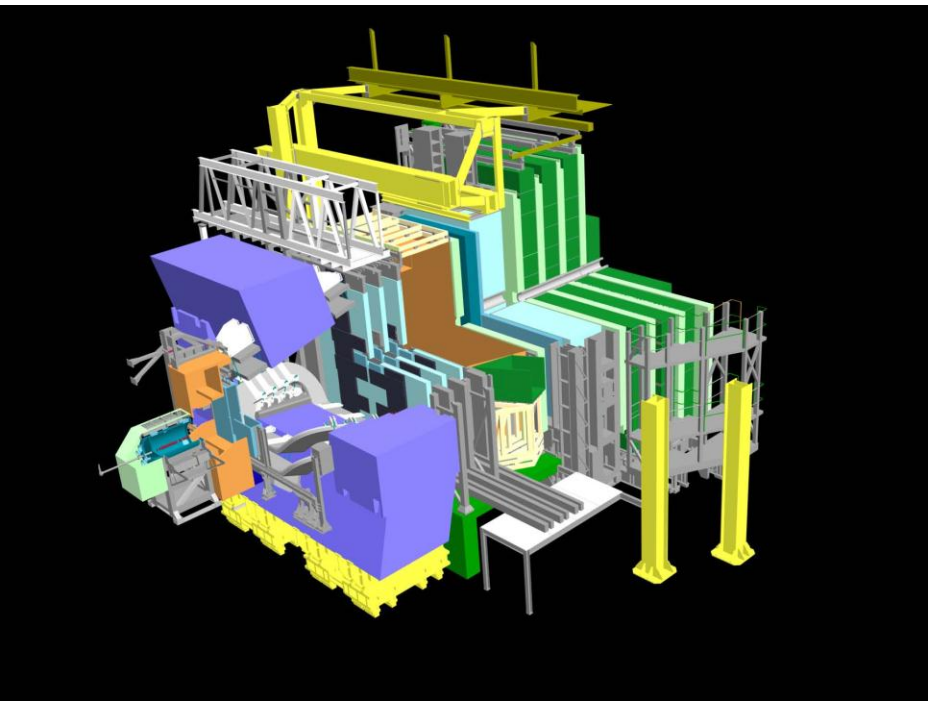
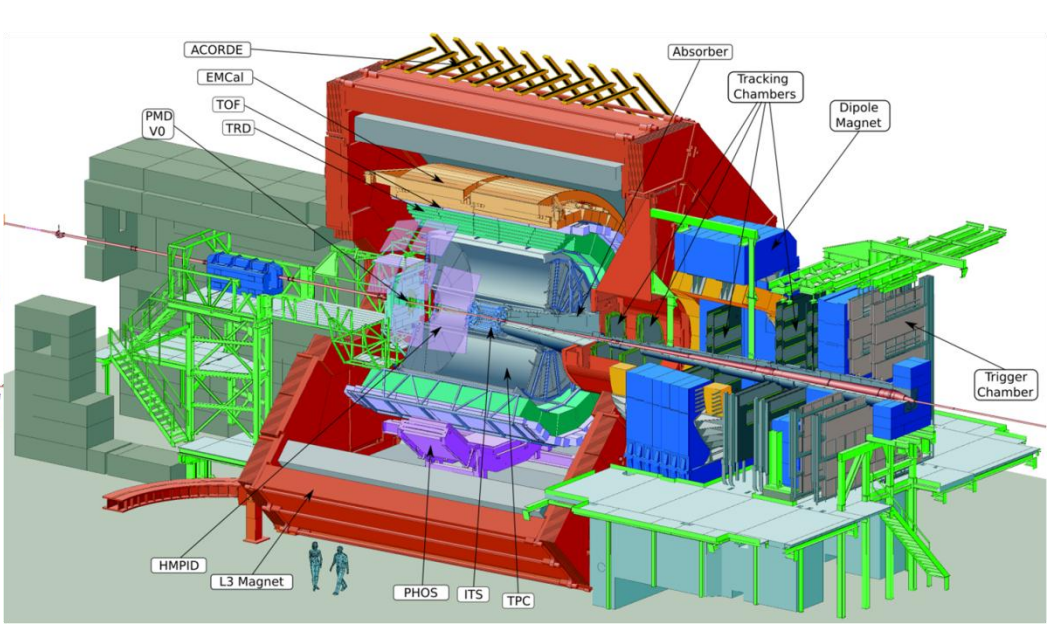
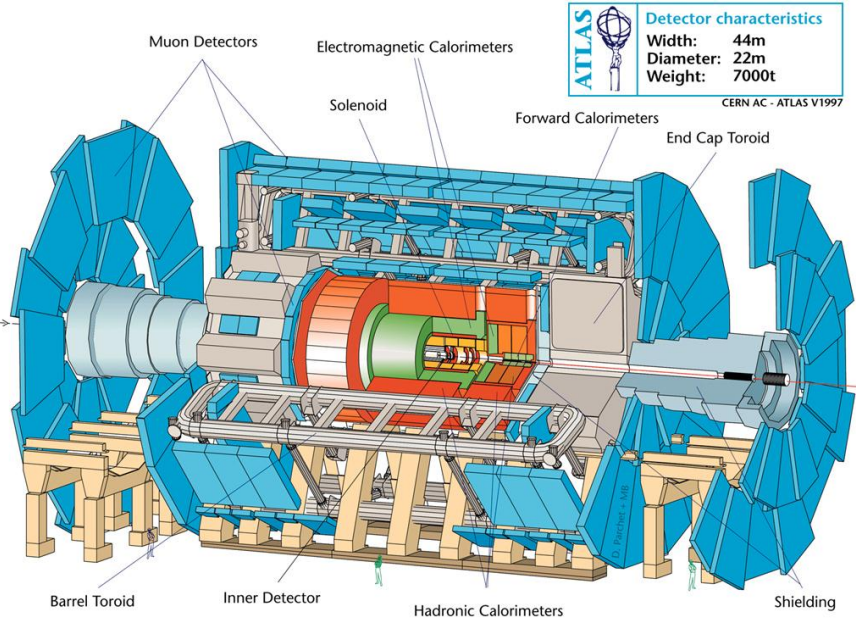

**Detector characteristics**  
 Width: 22m  
 Diameter: 15m  
 Weight: 14500t

Vertex Detector

Inner Tracking Chamber

Time Projection Chamber

Electromagnetic Calorimeter

Hadron Calorimeter

Muon Detectors

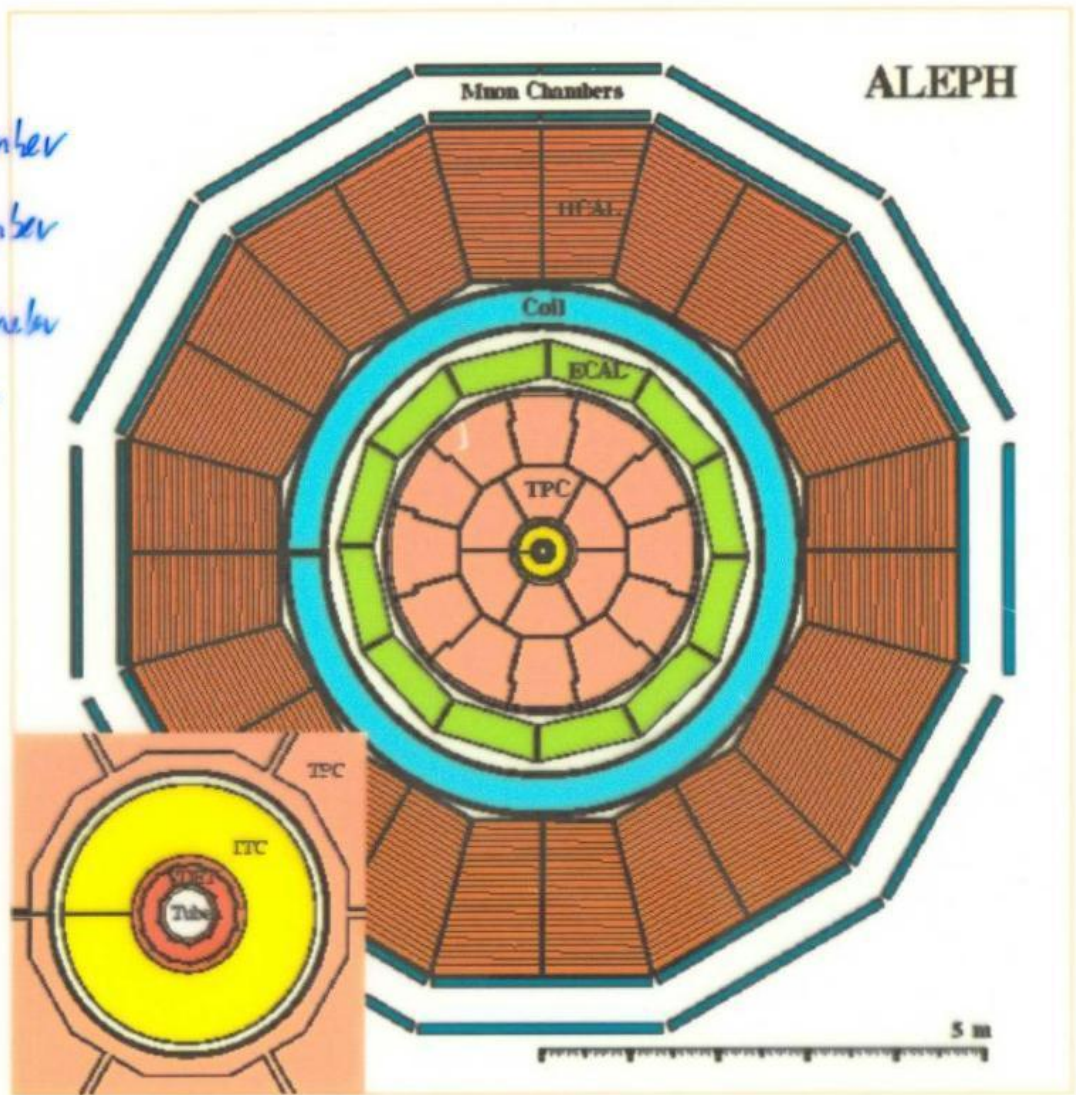

ALEPH

5 m

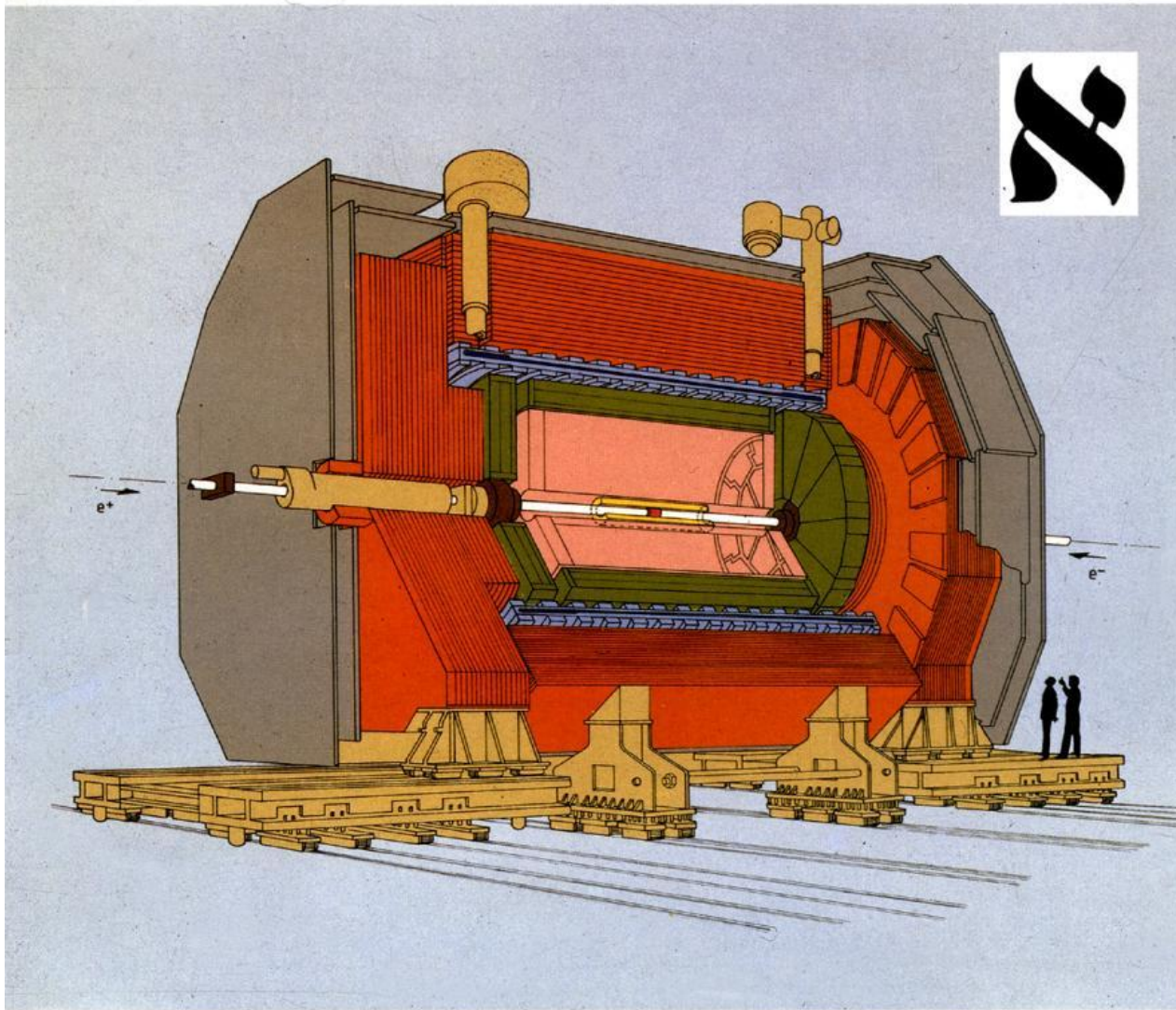









-  Vertex Detector
-  Inner Track Chamber
-  Time Projection Chamber
-  Electromagnetic Calorimeter
-  Superconducting Magnet Coil
-  Hadron Calorimeter
-  Muon Detection Chambers
-  Luminosity Monitors

Fig. 1 - The ALEPH Detector

$\gamma, e^{\pm}, \pi^{\pm}, k^{\pm}$   
 $k^0, p, n, \mu^{\pm}$



# CMS A Compact Solenoidal Detector for LHC

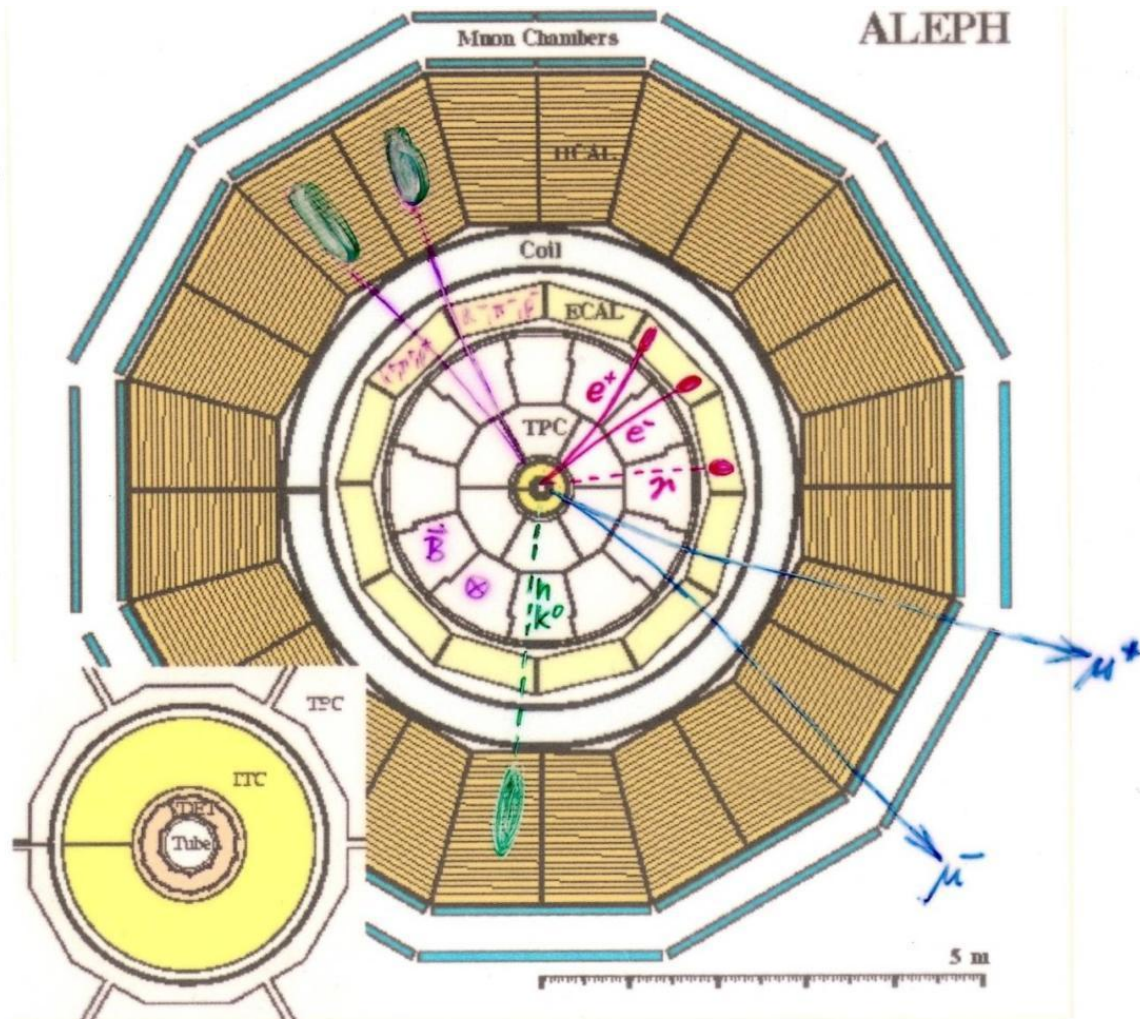
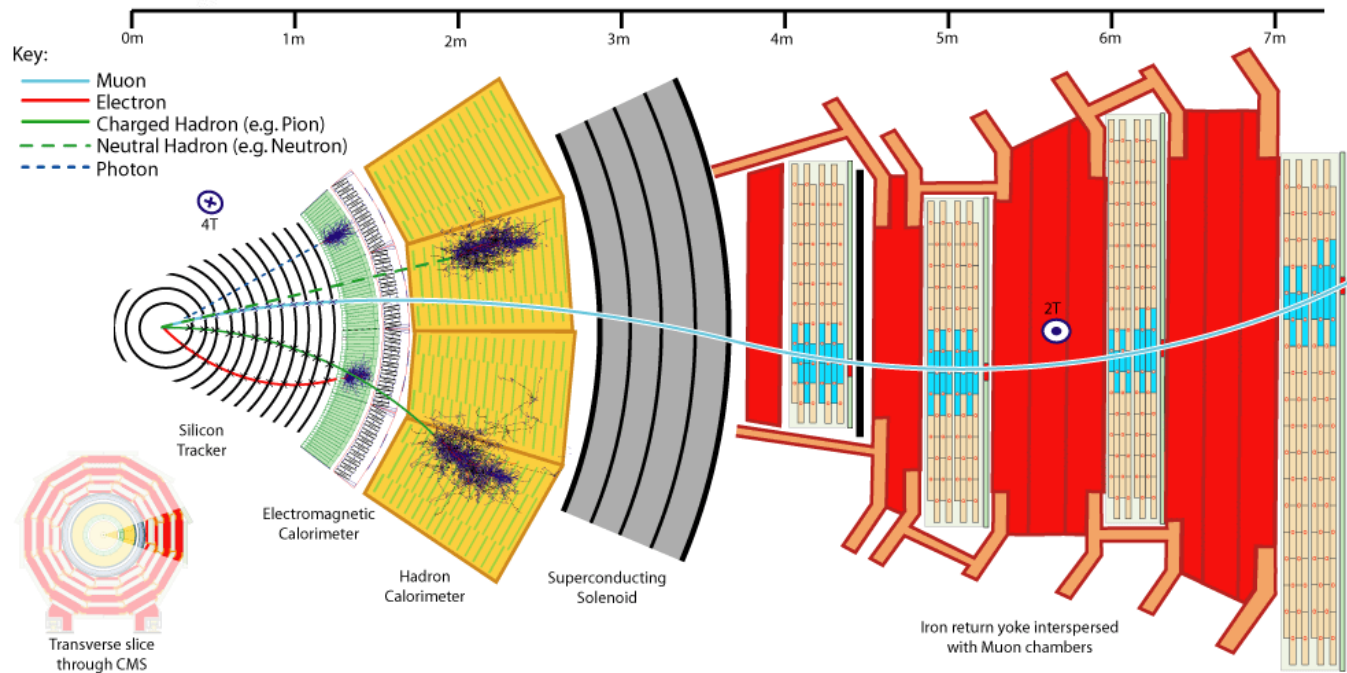
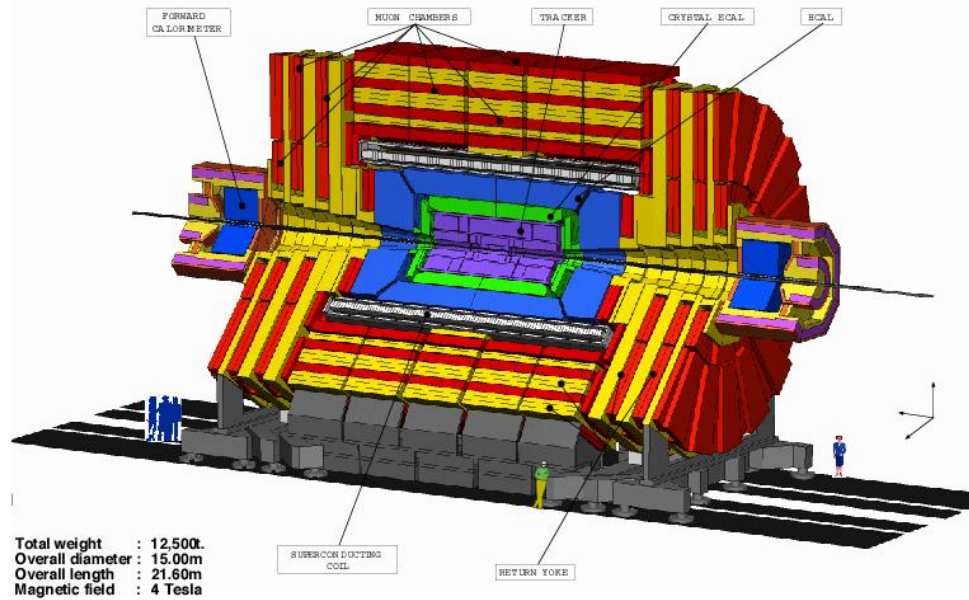

$$Z \rightarrow e^+ e^-$$

Two high momentum charged particles depositing energy in the Electro Magnetic Calorimeter

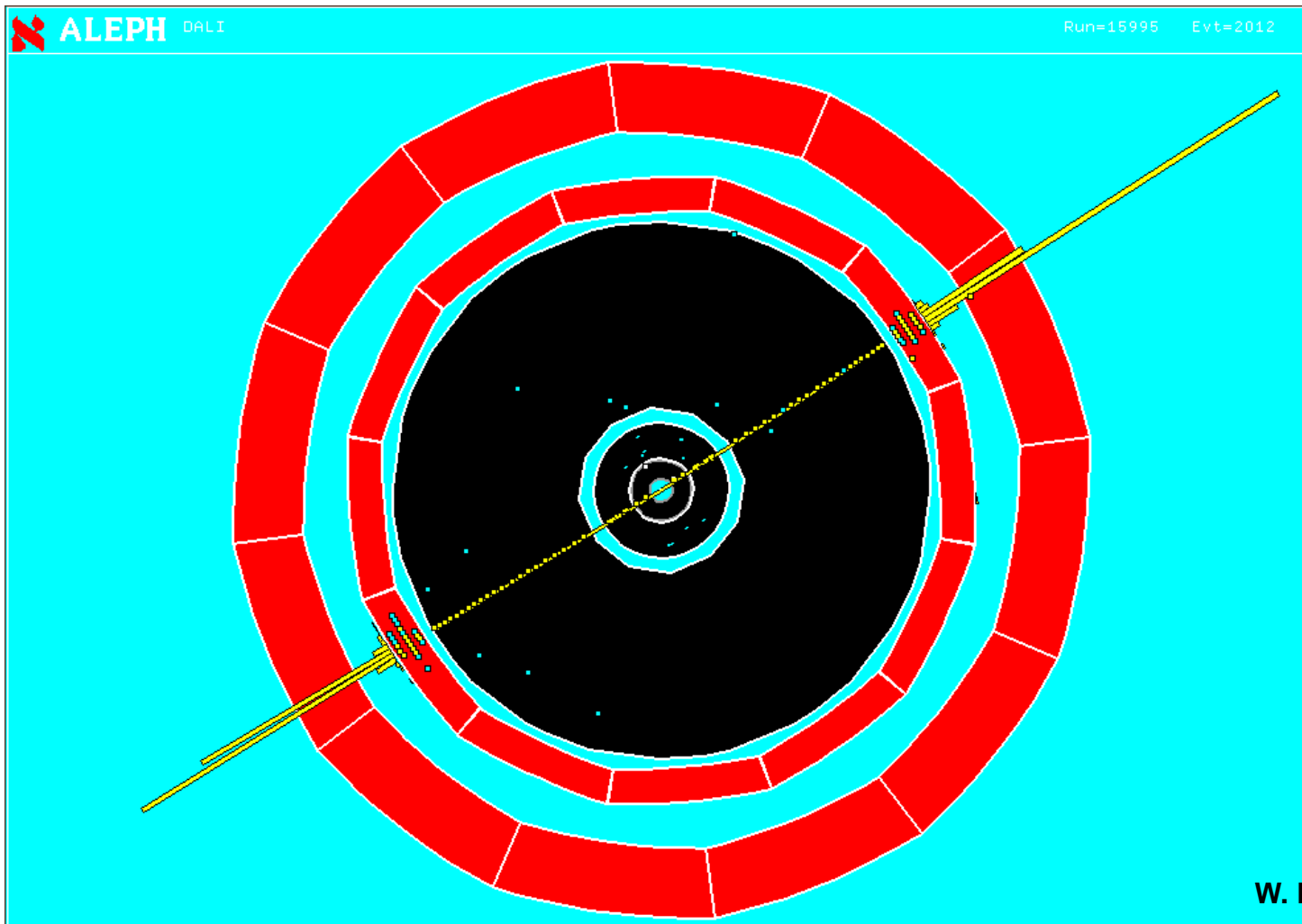



$$Z \rightarrow \mu^+ \mu^-$$

Two high momentum charged particles traversing all calorimeters and leaving a signal in the muon chambers.

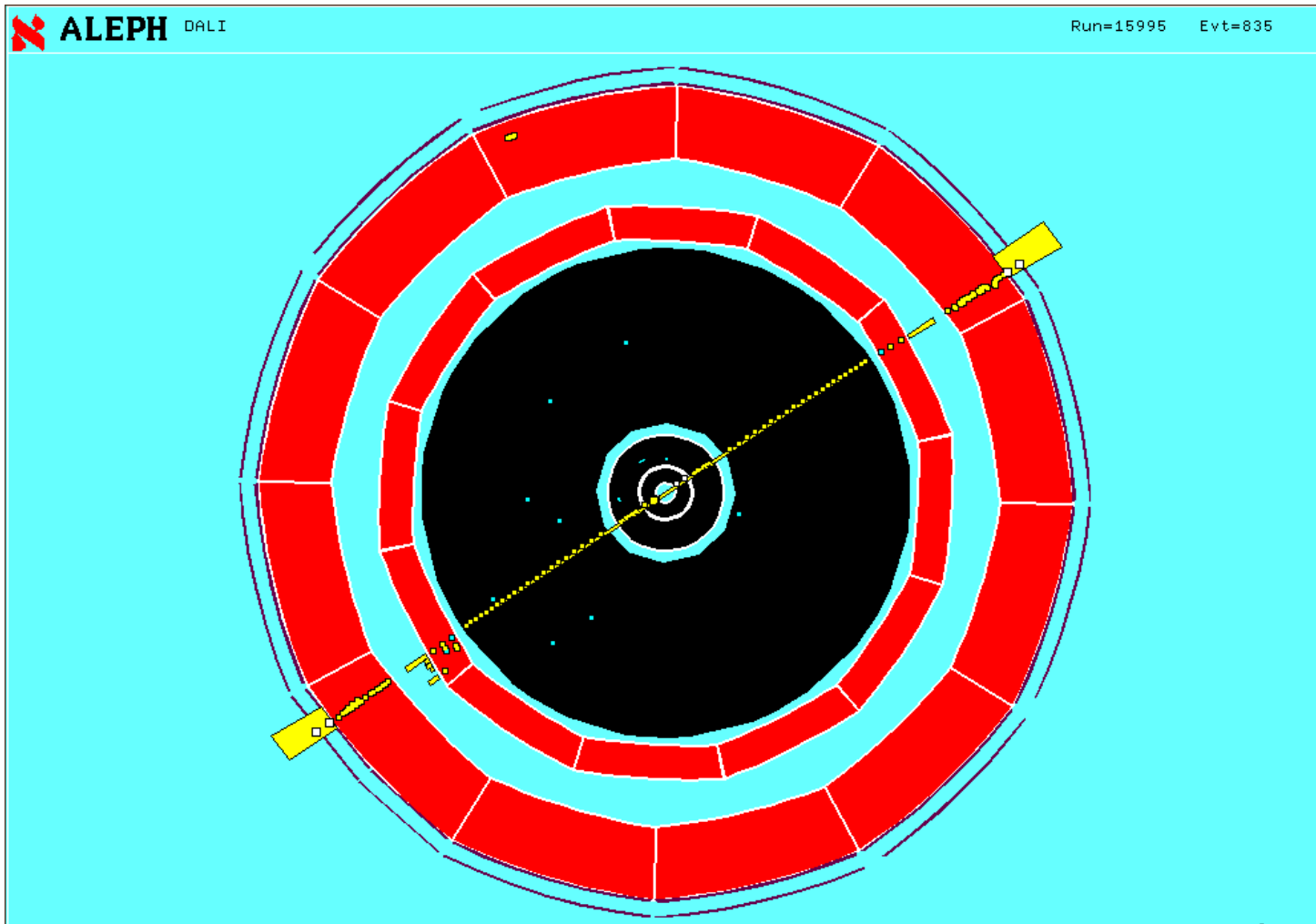

# Interaction of Particles with Matter

Any device that is to detect a particle must interact with it in some way → almost ...

In many experiments neutrinos are measured by missing transverse momentum.

E.g.  $e^+e^-$  collider.  $P_{\text{tot}}=0$ ,

If the  $\Sigma p_i$  of all collision products is  $\neq 0$  → neutrino escaped.



“Did you see it?”

“No nothing.”

“Then it was a neutrino!”

$$W^+W^- \rightarrow e^+ \gamma + \mu^- e^+ \gamma$$

# Single electron, single Muon, Missing Momentum

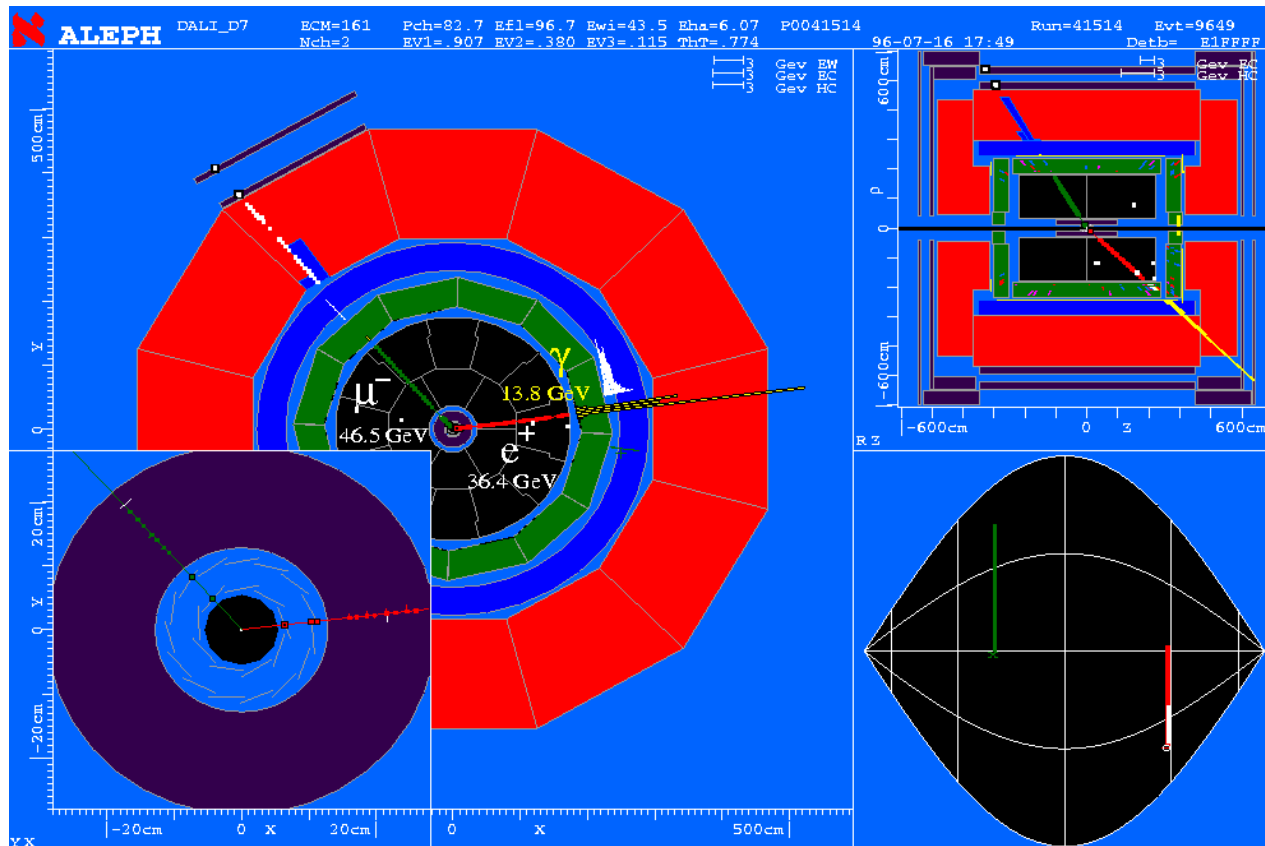

$$Z \rightarrow q \bar{q}$$

Two jets of particles

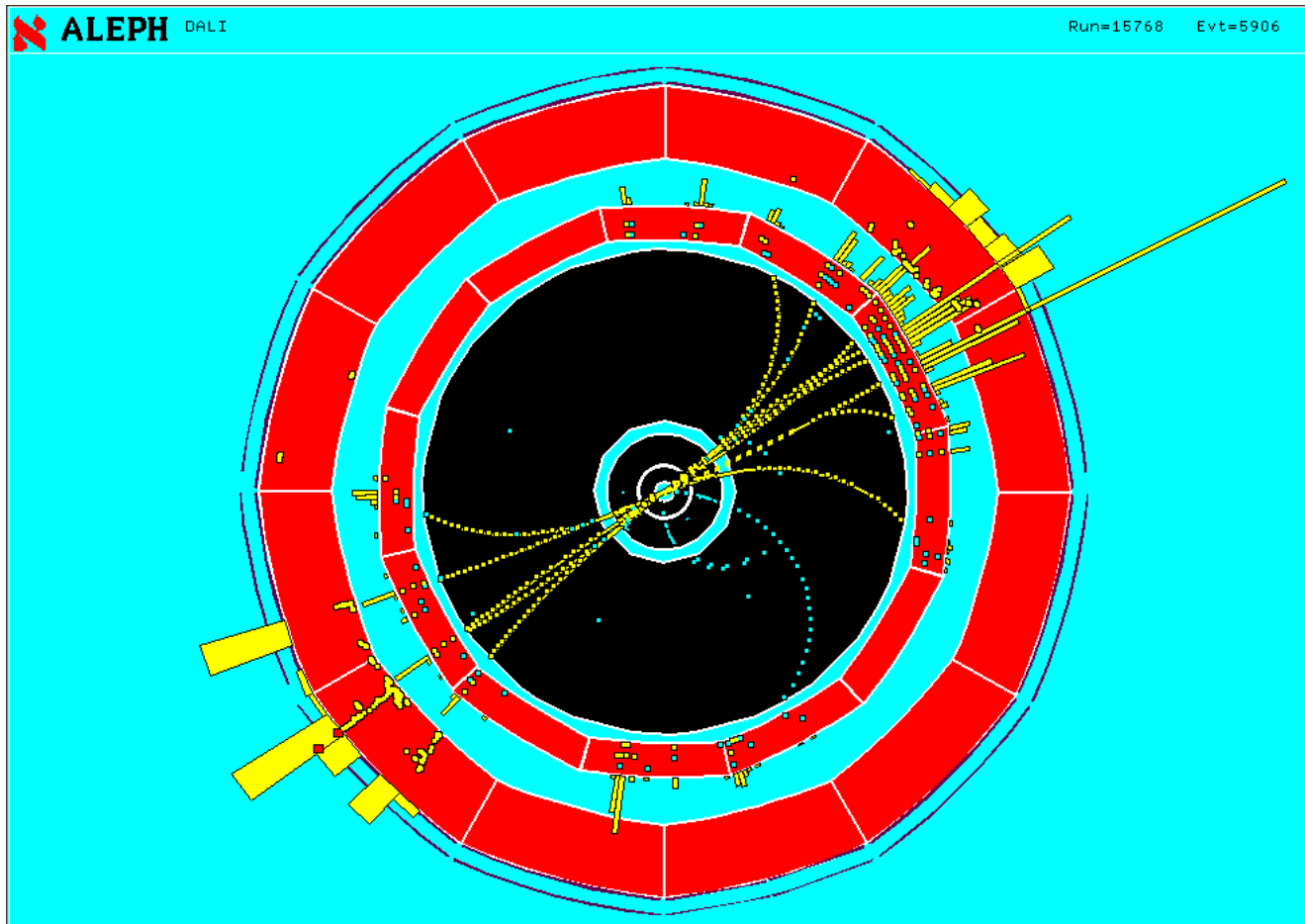

$$Z \rightarrow q \bar{q} g$$

Three jets of particles

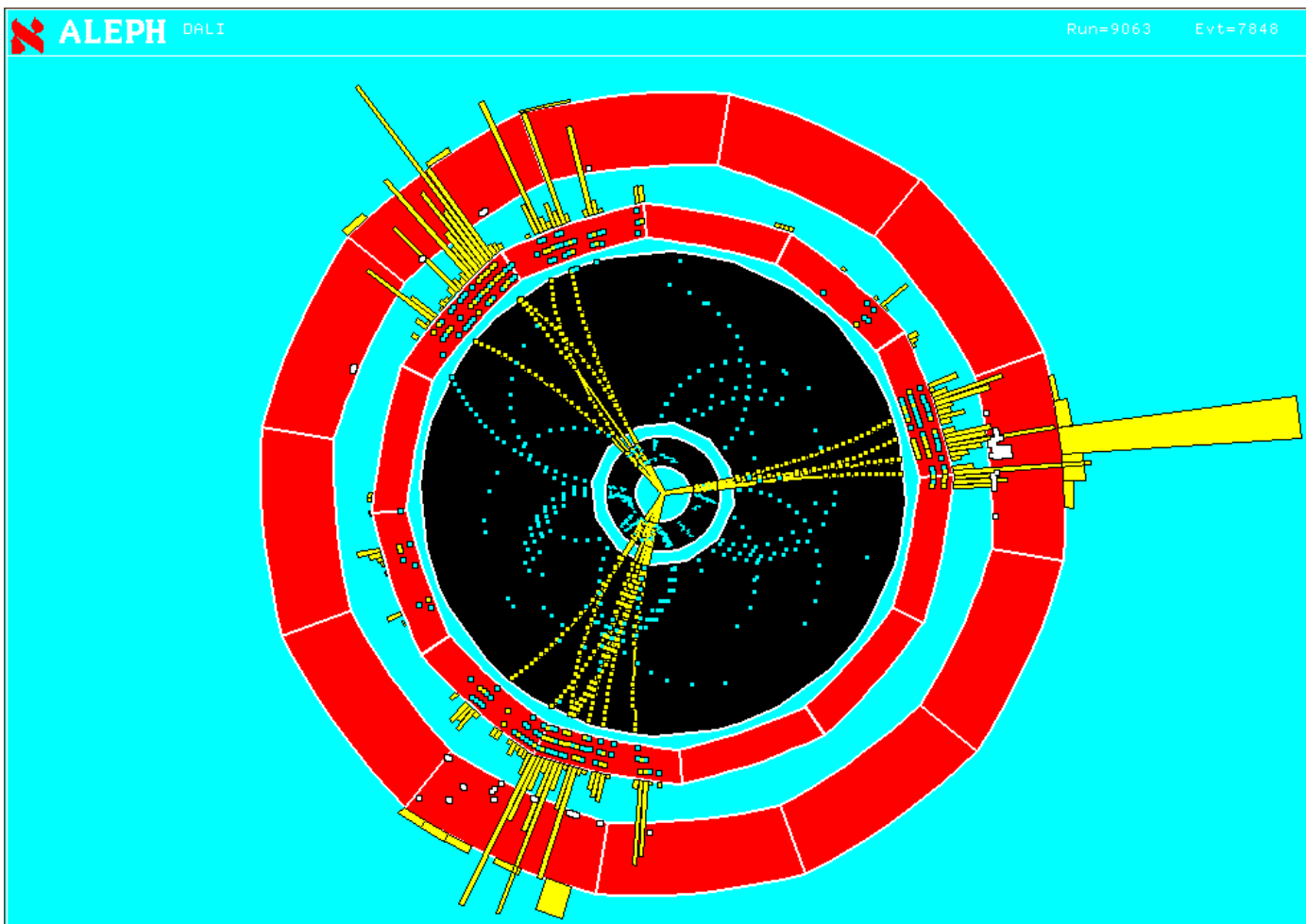

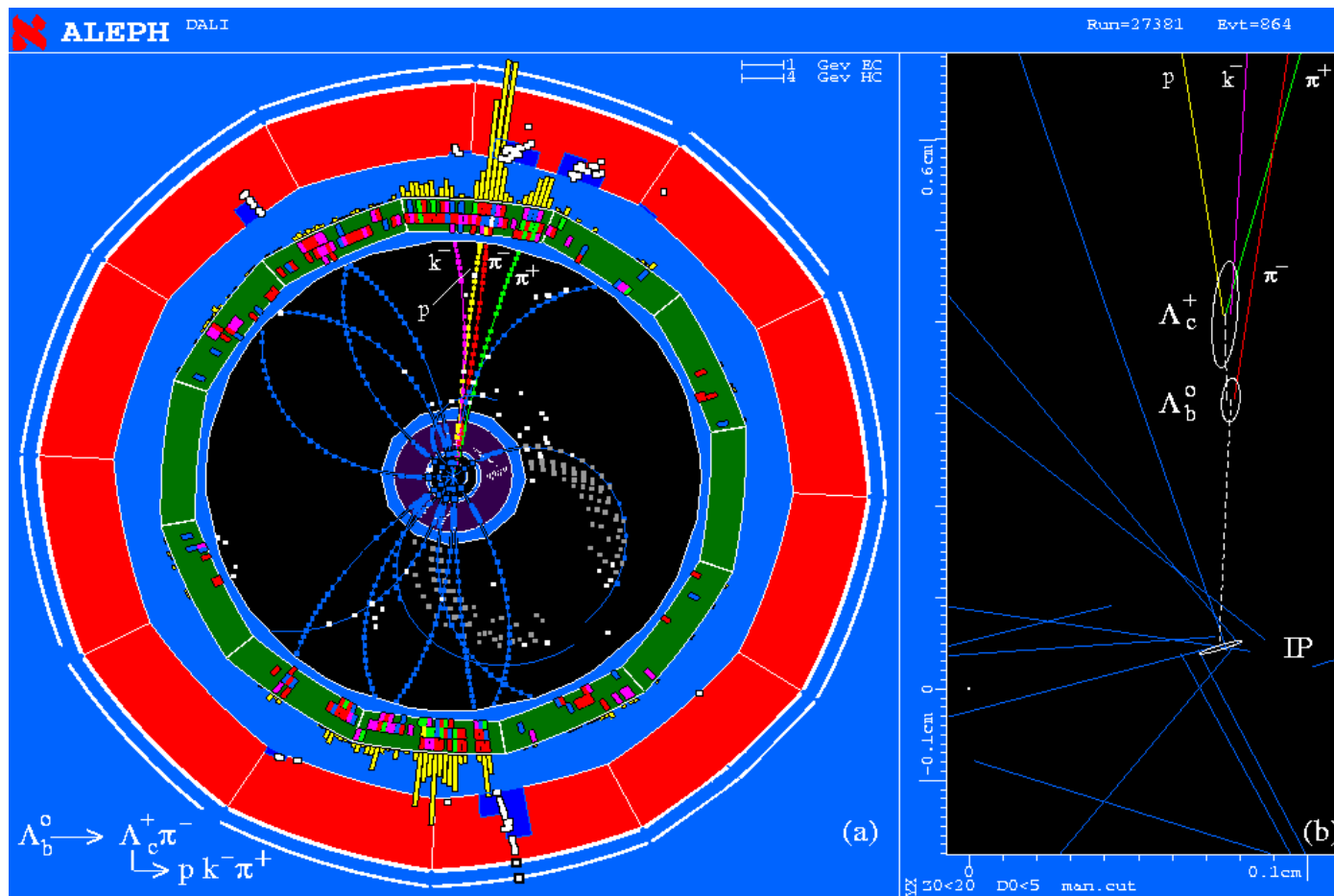

Two secondary vertices with characteristic decay particles giving invariant masses of known particles.

Bubble chamber like – a single event tells what is happening. Negligible background.

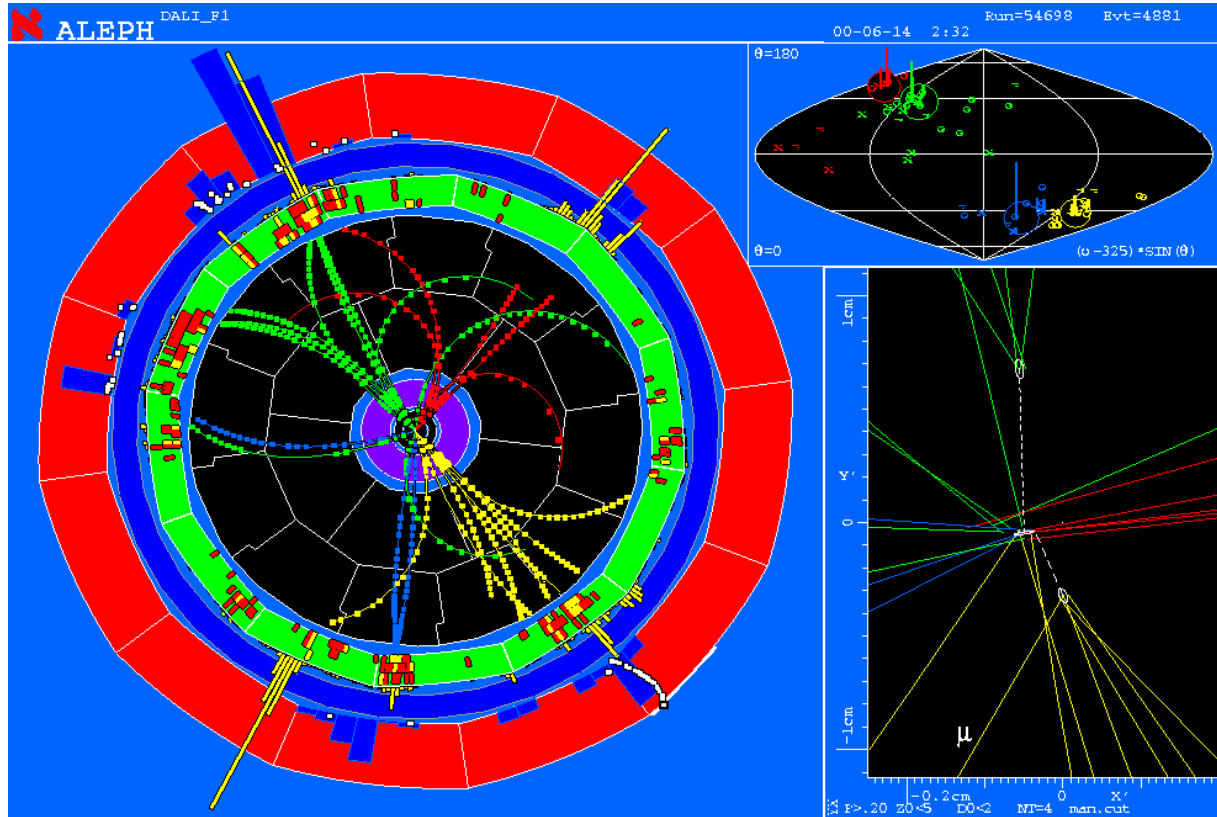

# ALEPH Higgs Candidate

$e^+e^- \rightarrow Z + H$   
 $L \rightarrow b\bar{b}$   
 $L \rightarrow \text{jet} + \text{jet}$



Undistinguishable background exists. Only statistical excess gives signature.

# 2010 ATLAS W, Z candidates !

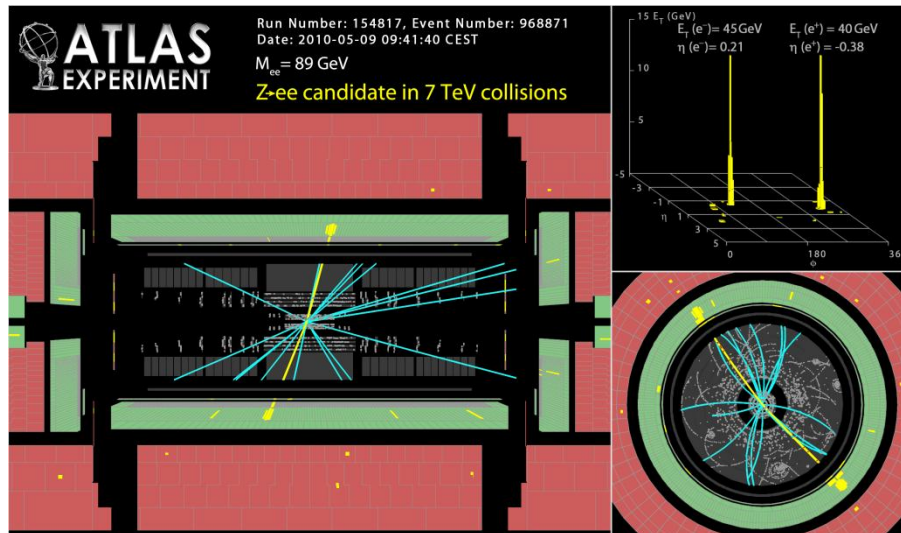
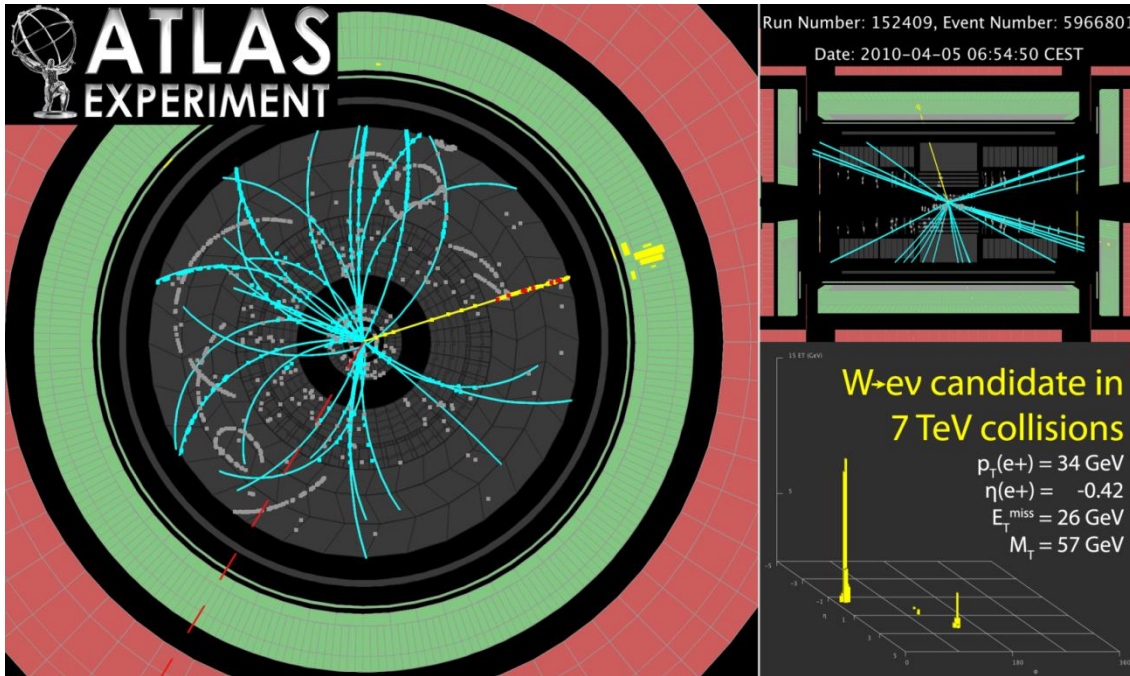



# 2010 ATLAS W, Z candidates !

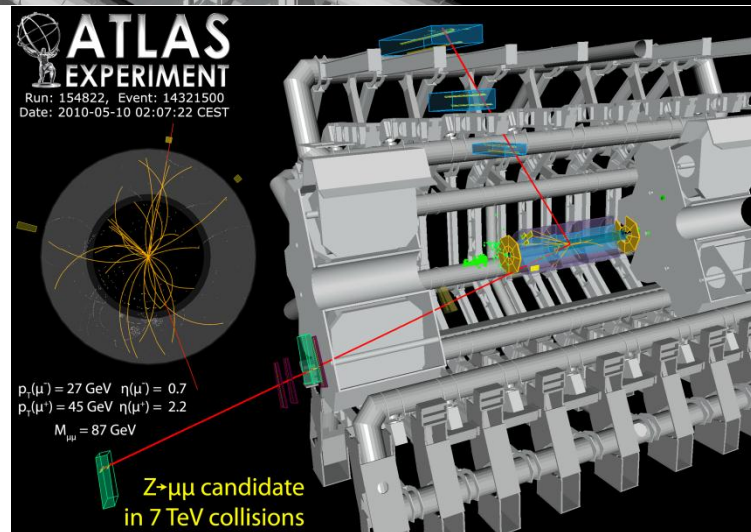
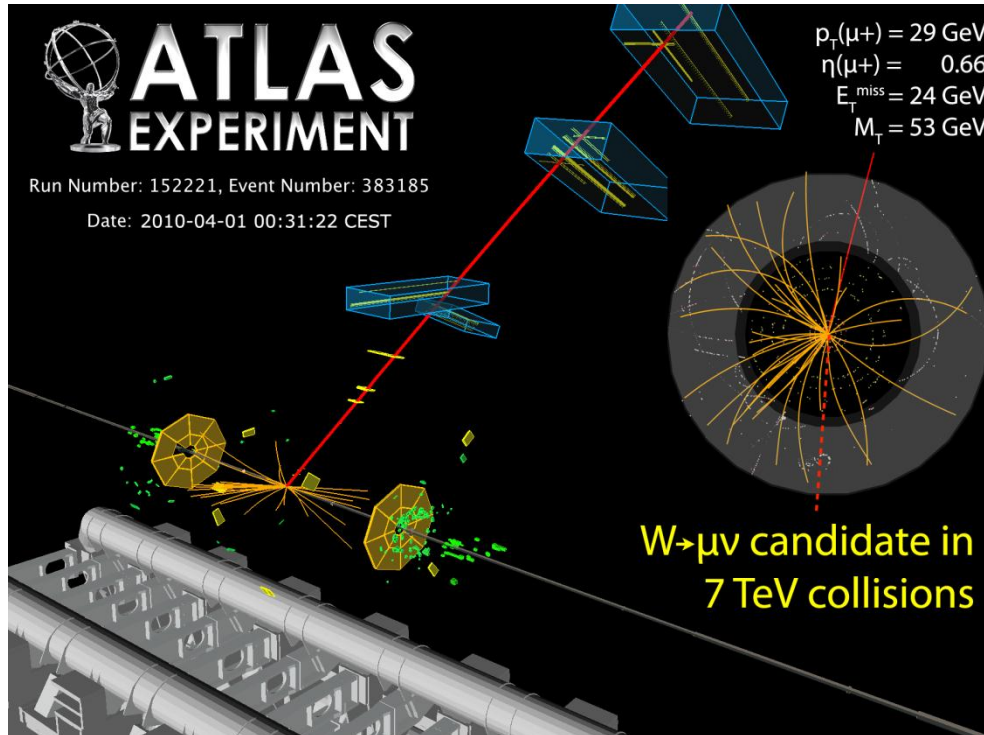

# Higgs Boson at CMS

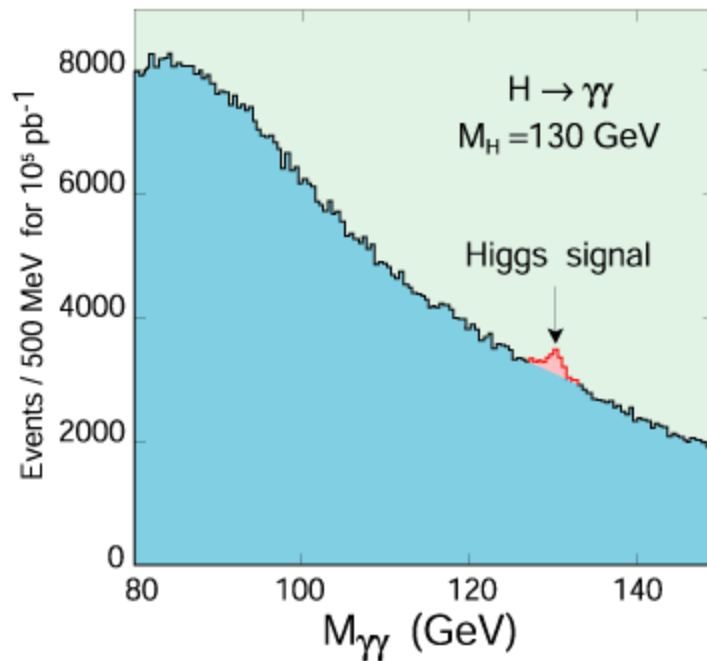
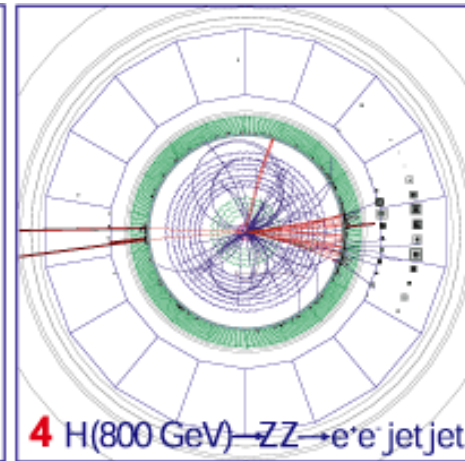
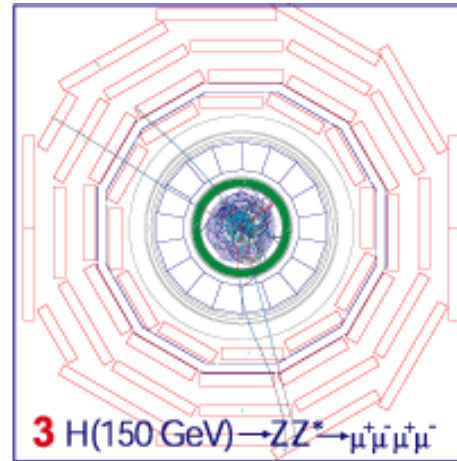
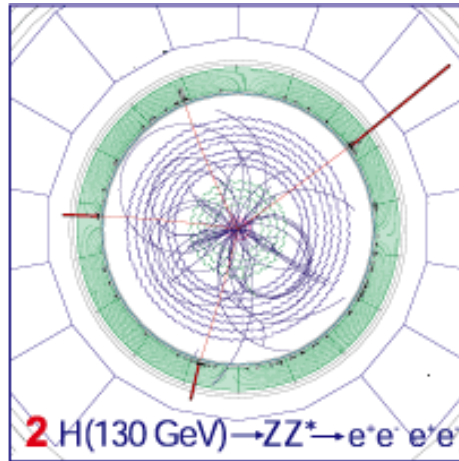
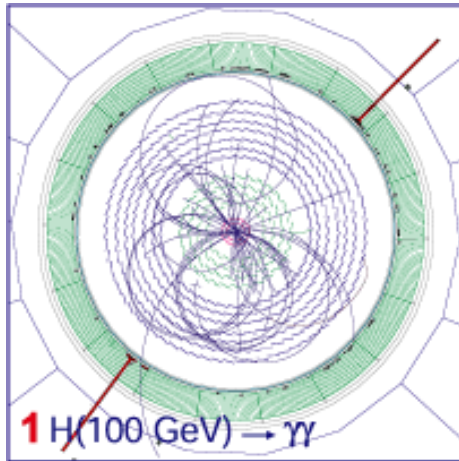

Particle seen as an excess of two photon events above the irreducible background.

# Principles:

Only a few of the numerous known particles have lifetimes that are long enough to leave tracks in a detector.

Most of the particles are measured through the decay products and their kinematic relations (invariant mass). Most particles are only seen as an excess over an irreducible background.

Some short lived particles (b,c –particles) reach lifetimes in the laboratory system that are sufficient to leave short tracks before decaying → identification by measurement of short tracks.

In addition to this, detectors are built to measure the  
8 particles

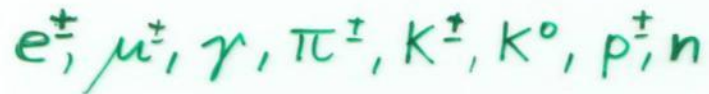

$e^{\pm}, \mu^{\pm}, \gamma, \pi^{\pm}, K^{\pm}, K^0, p^{\pm}, n$

Their difference in mass, charge and interaction is the key to their identification.

# Detector Technologies

Solid state detectors close to the collision point for excellent position resolution to find primary and secondary vertices → **silicon pixel detectors**.

Solid state detectors (**silicon strip detectors**) or **gas detectors** at larger distances for tracking and momentum measurement.

Massive **calorimeters** with alternating layers of passive absorber material and active detector material for measurement of particle energies.

# Silicon Pixel Detectors

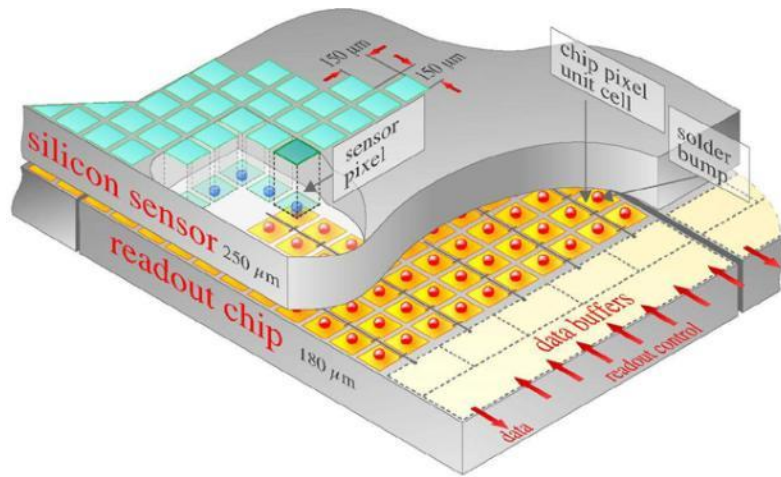

ATLAS:  $1.4 \times 10^8$  pixels

40 000 000 'images' per second.

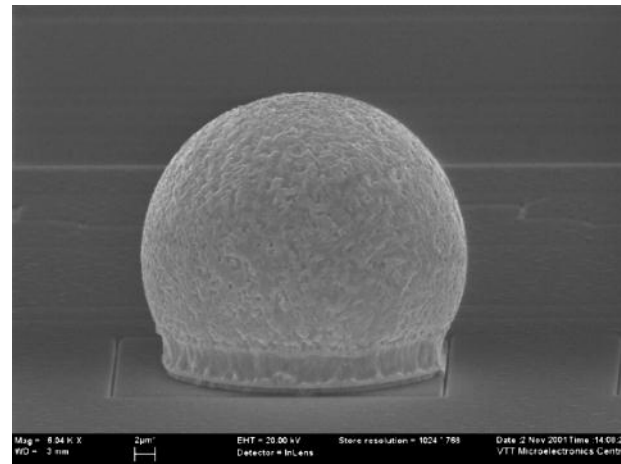
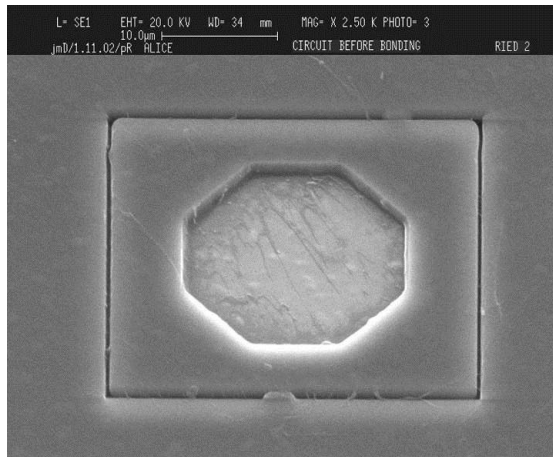

# ATLAS Silicon Pixel Detector

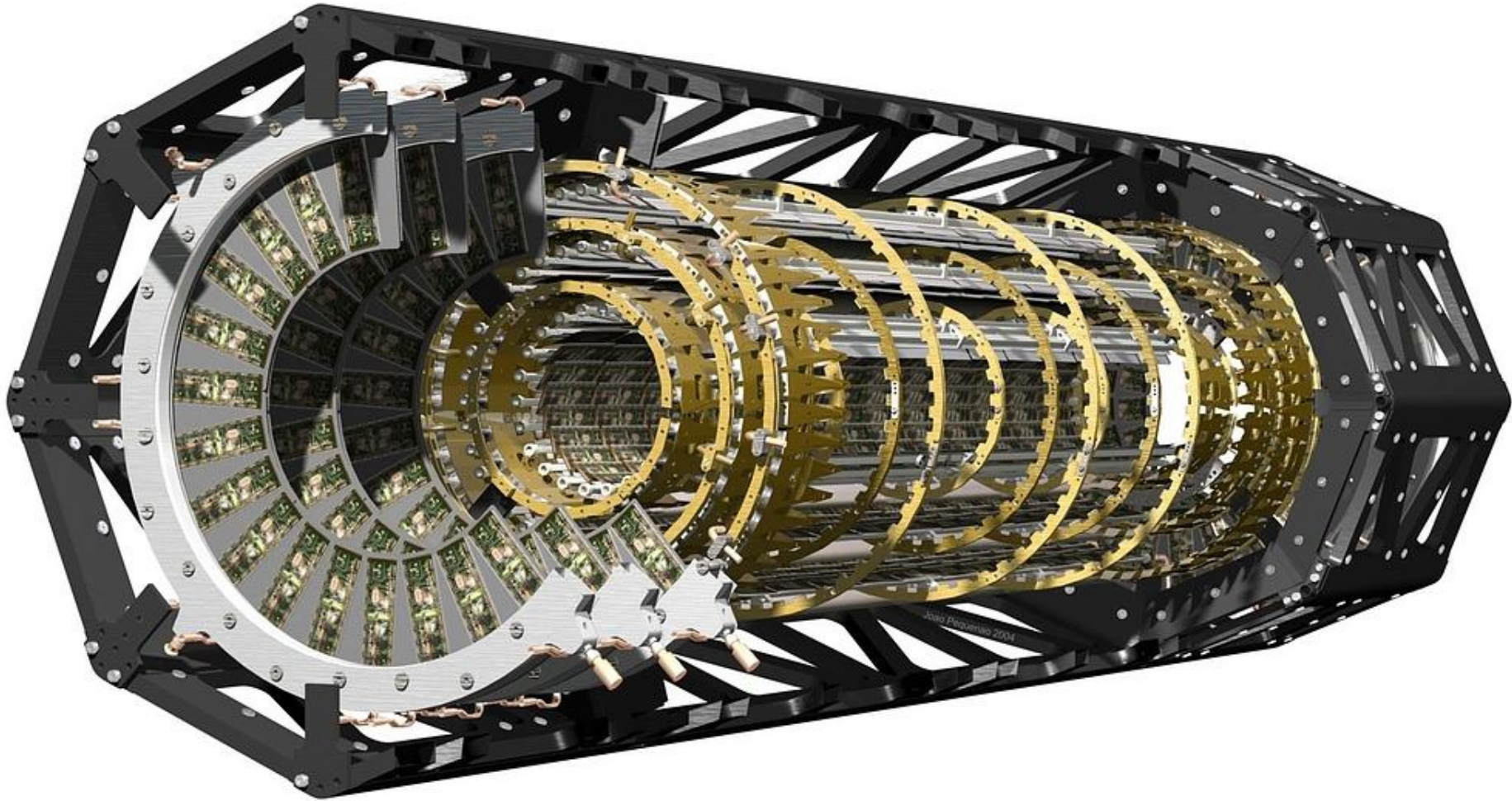

# Silicon Strip Detectors

Every electrode is connected to an amplifier →  
Highly integrated readout electronics.

Two dimensional readout is possible.

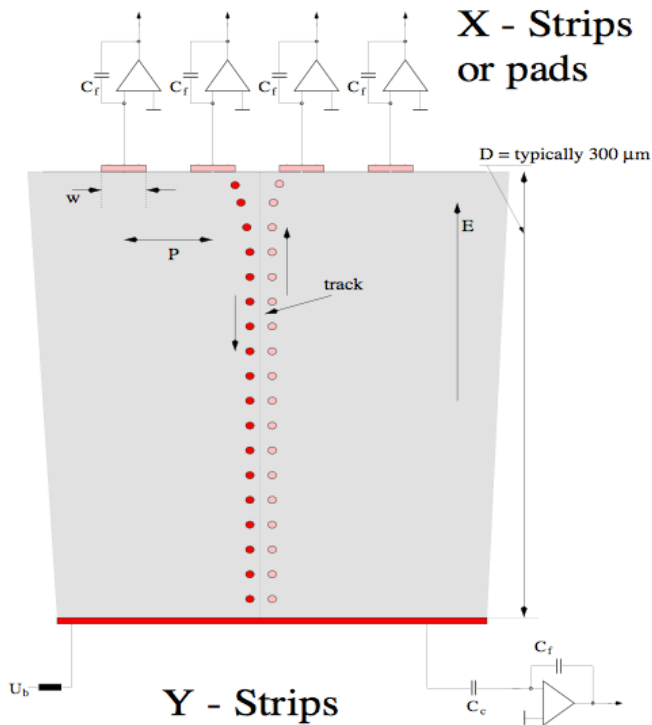

## CMS Outer Barrel Module

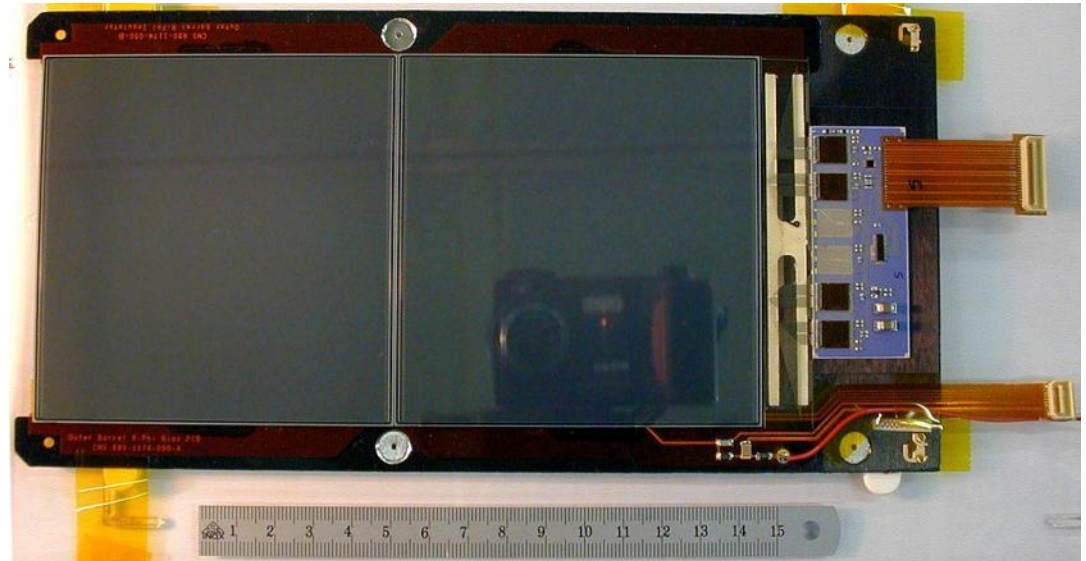

# Silicon Strip Detectors

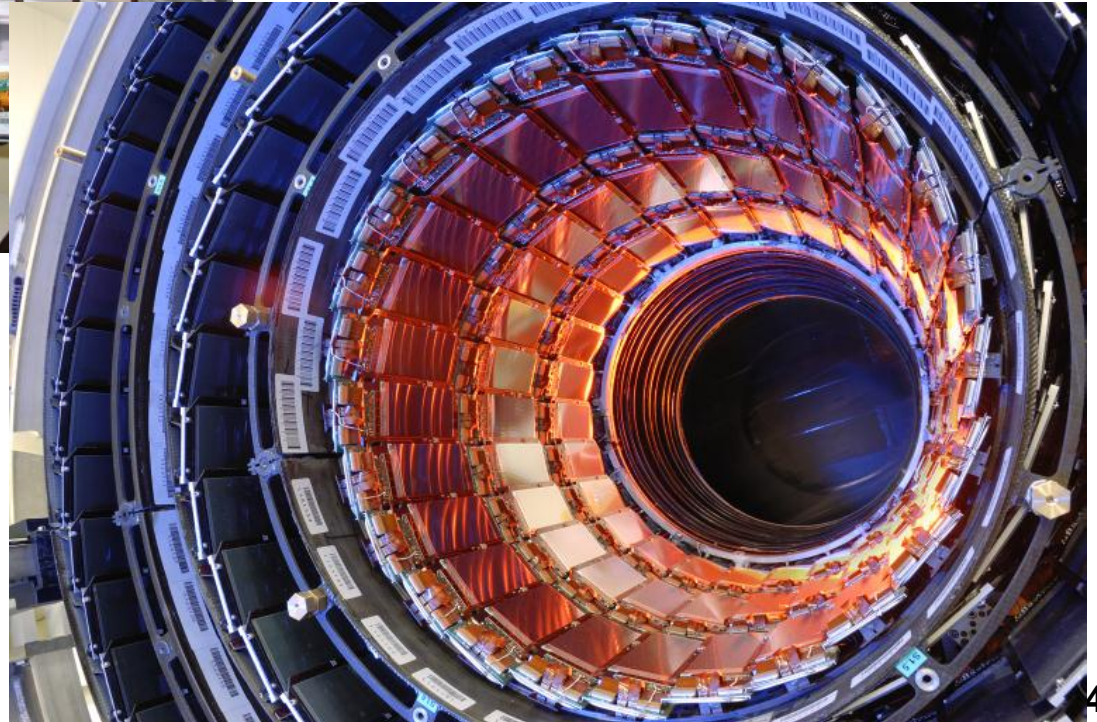



# Time Projection Chamber (TPC):

Gas volume with parallel E and B Field.

B for momentum measurement. Positive effect:

Diffusion is strongly reduced by E/B (up to a factor 5).

Drift Fields 100-400V/cm. Drift times 10-100  $\mu$ s.

Distance up to 2.5m !

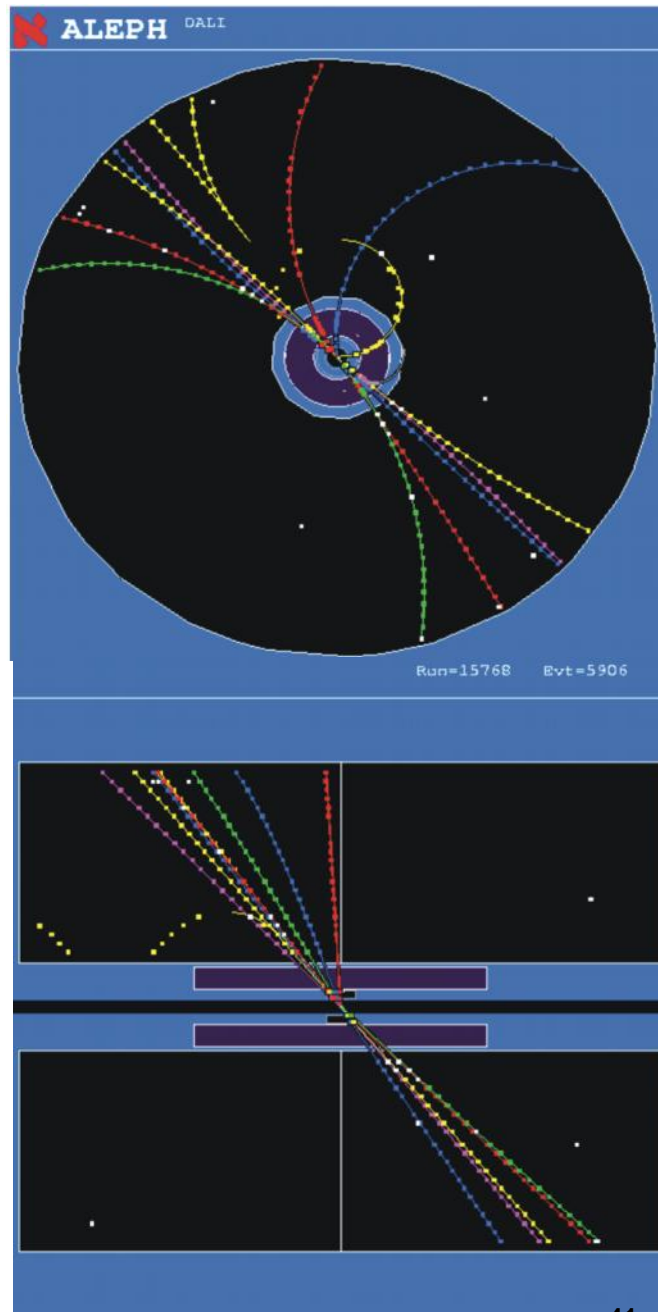
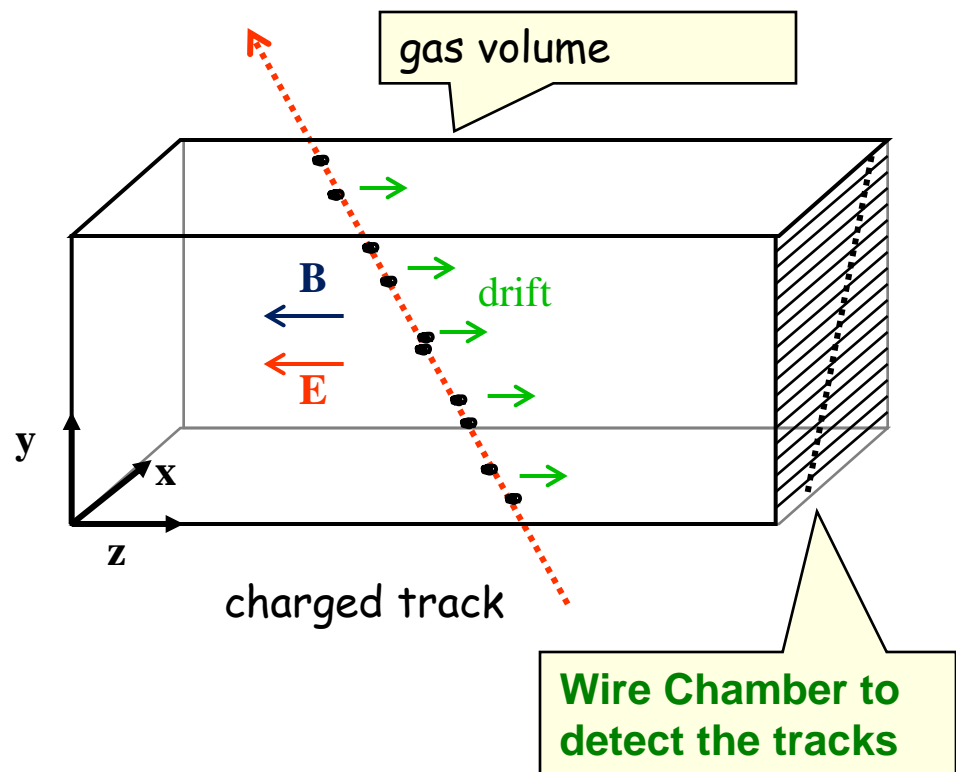

# ALICE TPC: Construction Parameters

- **Largest TPC:**
  - Length 5m
  - Diameter 5m
  - Volume 88m<sup>3</sup>
  - Detector area 32m<sup>2</sup>
  - Channels ~570 000
- **High Voltage:**
  - Cathode -100kV
- **Material  $X_0$** 
  - Cylinder from composite materials from airplane industry ( $X_0 = \sim 3\%$ )

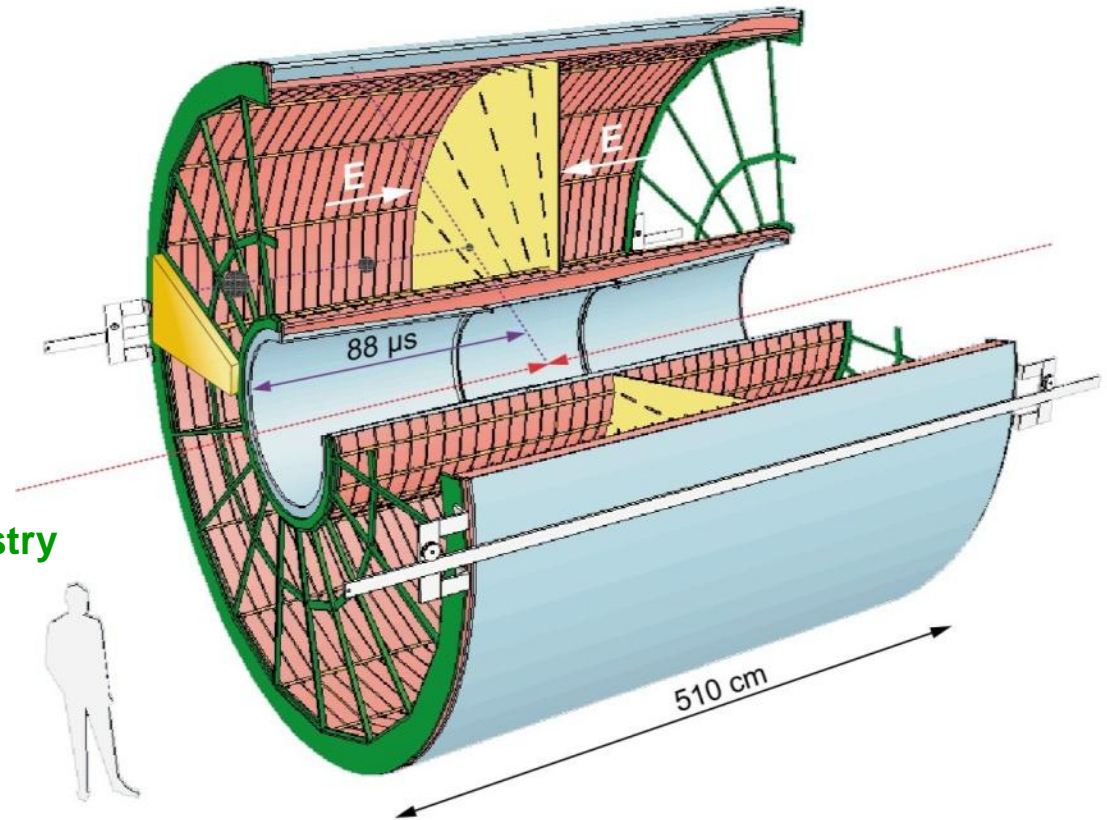

# ALICE TPC: Pictures of the Construction

Precision in z: 250 $\mu$ m

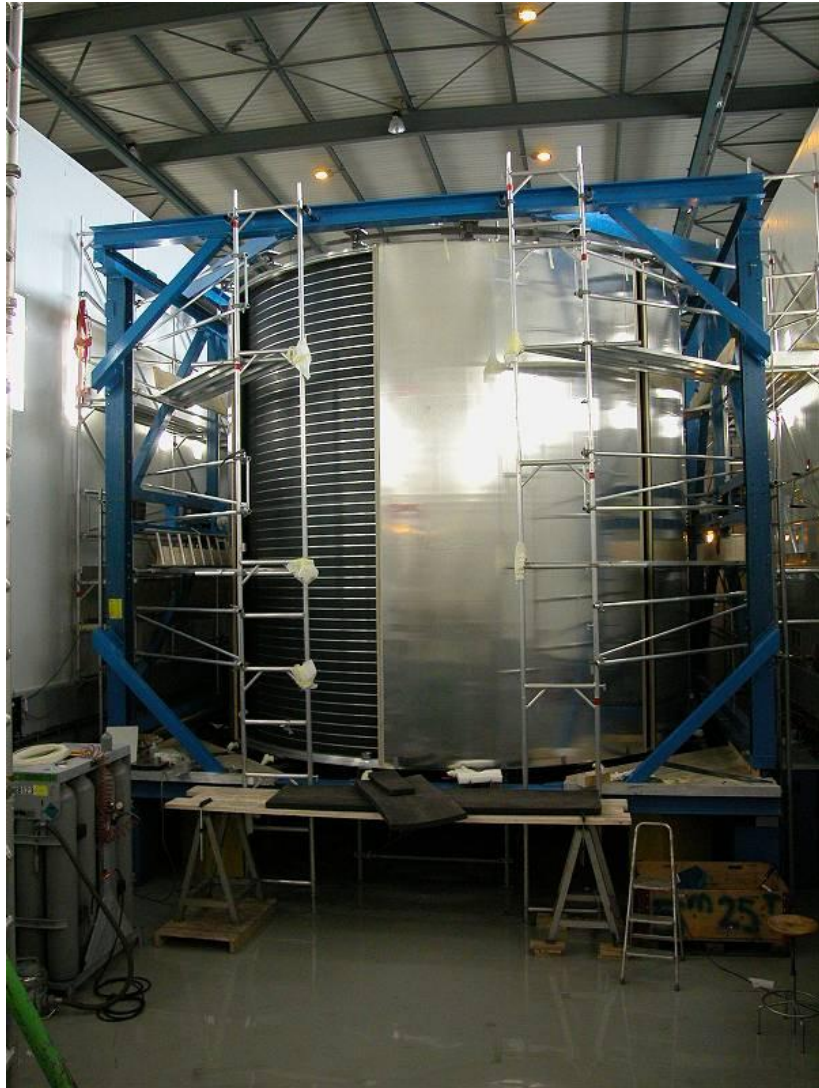

End plates 250 $\mu$ m



Wire chamber: 40 $\mu$ m

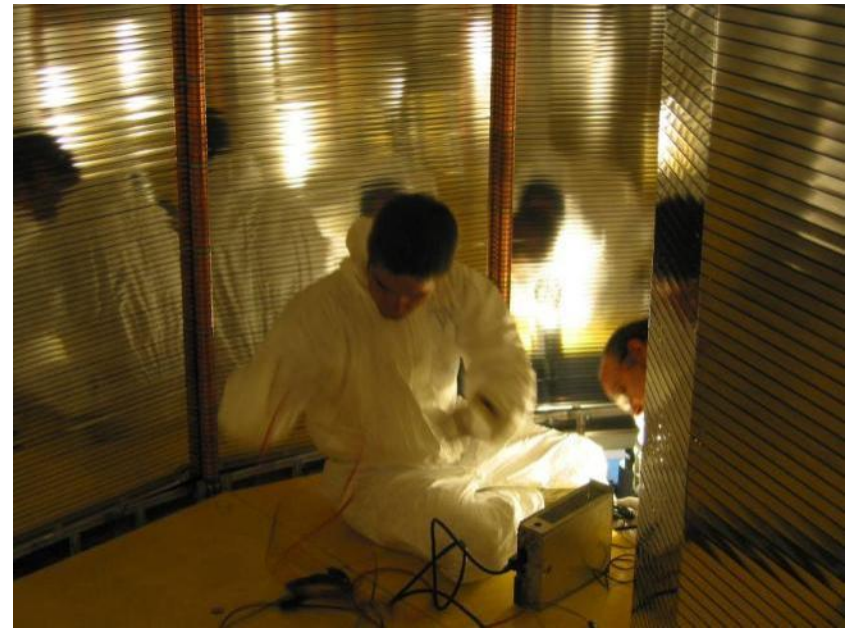

## ALICE TPC Construction

My personal contribution:

A visit inside the TPC.



# TPC installed in the ALICE Experiment

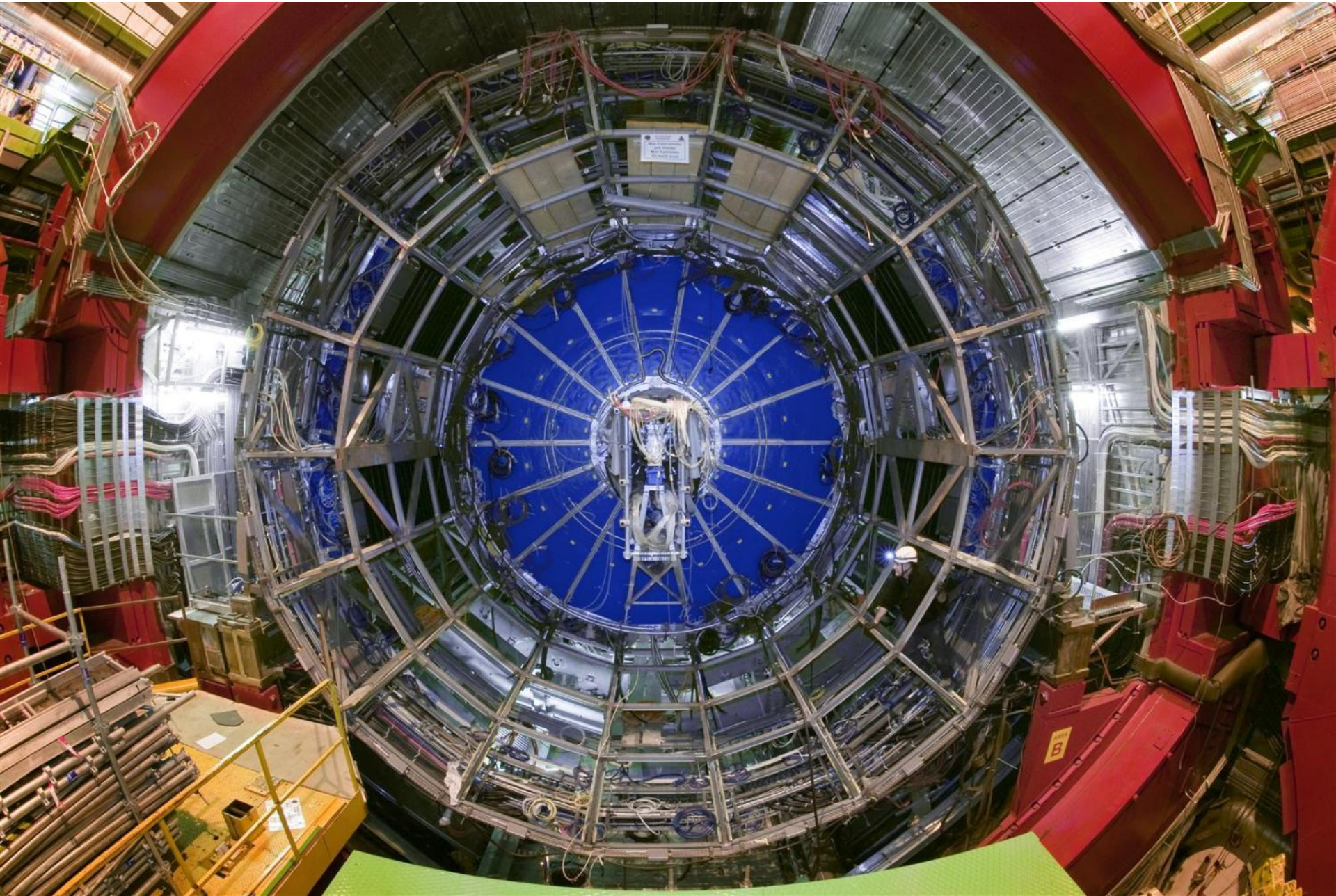

# First 7 TeV p-p Collisions in the ALICE TPC in March 2010 !

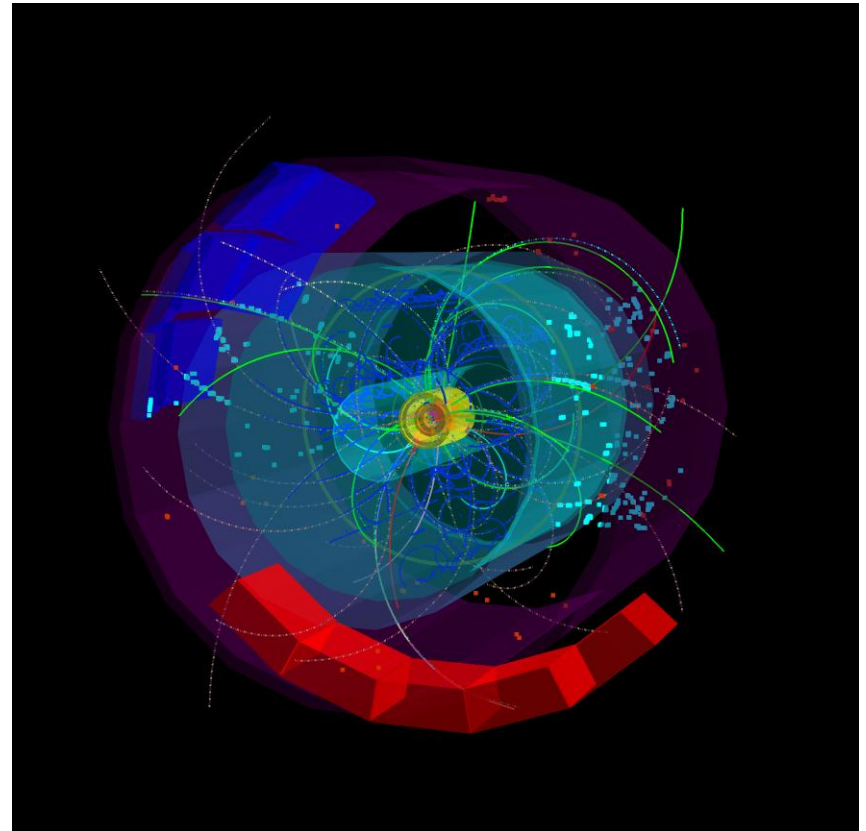
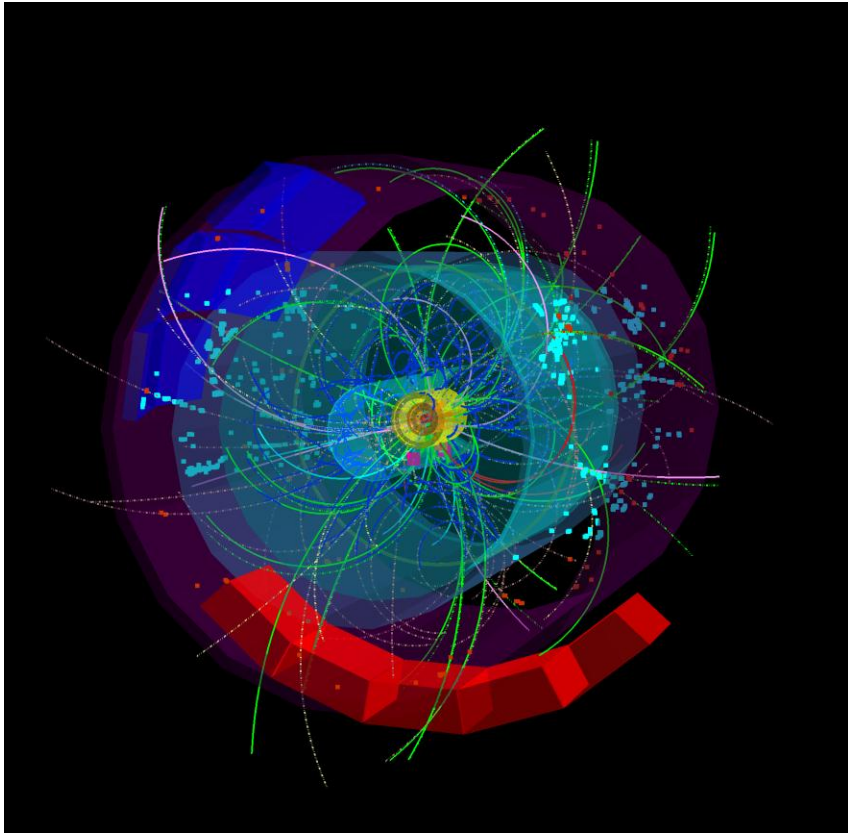

11/16/2011

# First Pb Pb Collisions in the ALICE TPC in Nov 2010 !

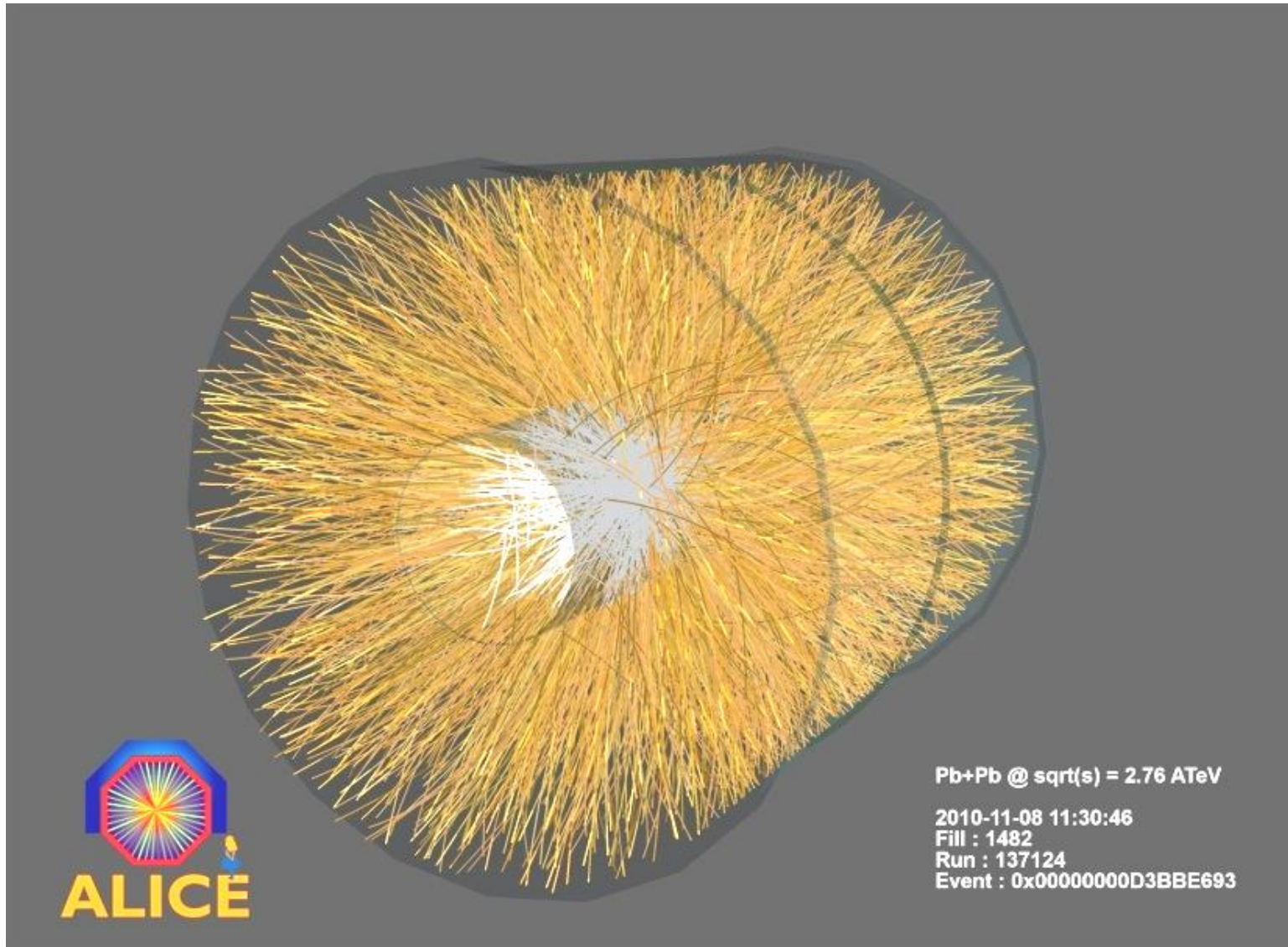

11/16/2011

# The Geiger Counter reloaded: Drift Tube

Primary electrons are drifting to the wire.

ATLAS MDT R(tube) = 15mm

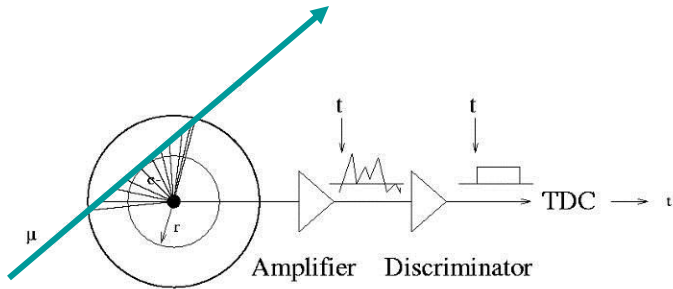

Calibrated Radius-Time correlation

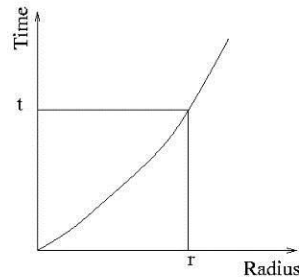

Electron avalanche at the wire.

The measured drift time is converted to a radius by a (calibrated) radius-time correlation.

Many of these circles define the particle track.

ATLAS Muon Chambers

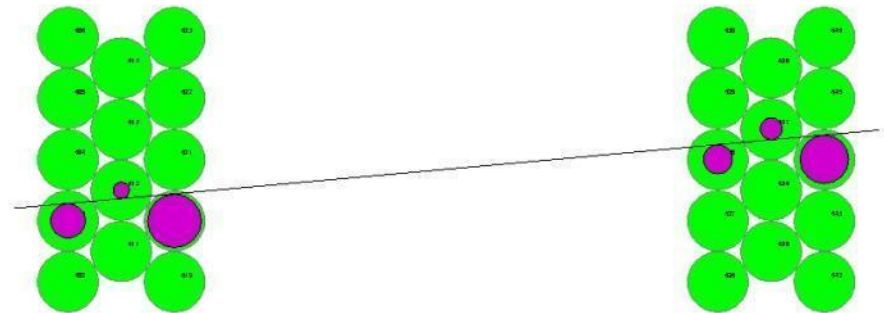
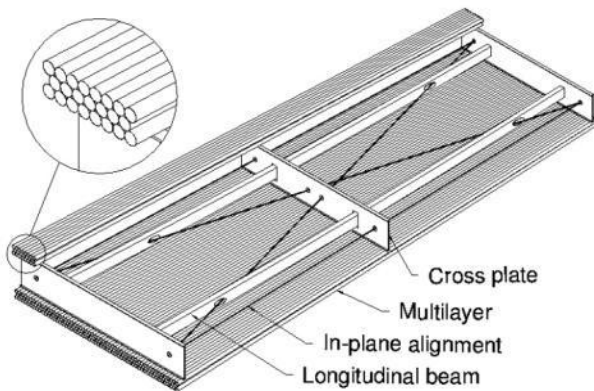

ATLAS MDTs, 80 $\mu$ m per tube



# The Geiger counter reloaded: Drift Tube

Atlas Muon Spectrometer, 44m long, from  $r=5$  to 11m.

1200 Chambers

6 layers of 3cm tubes per chamber.

Length of the chambers 1-6m !

Position resolution:  $80\mu\text{m}/\text{tube}$ ,  $<50\mu\text{m}/\text{chamber}$  (3 bar)

Maximum drift time  $\approx 700\text{ns}$

Gas Ar/CO<sub>2</sub> 93/7

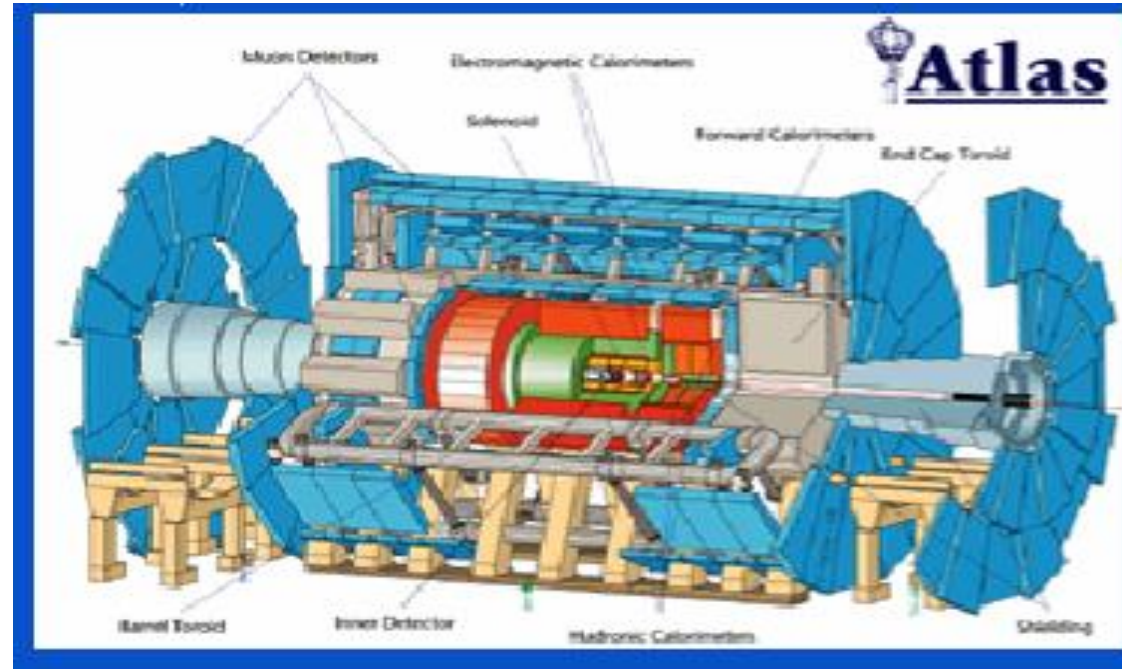
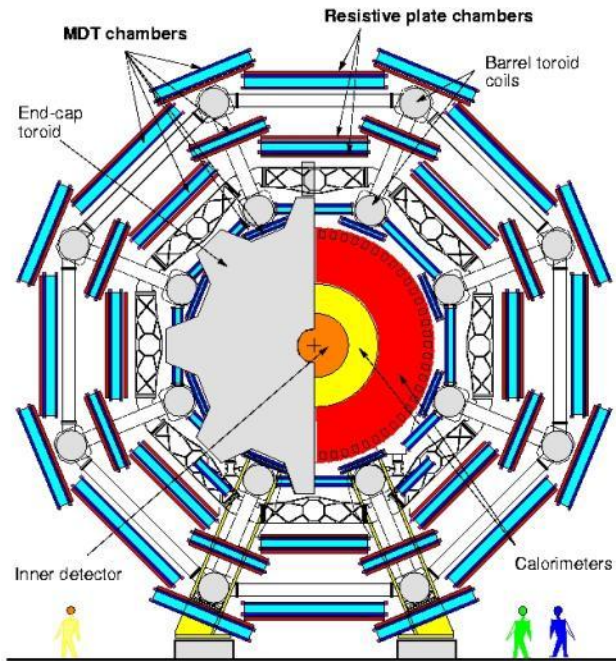
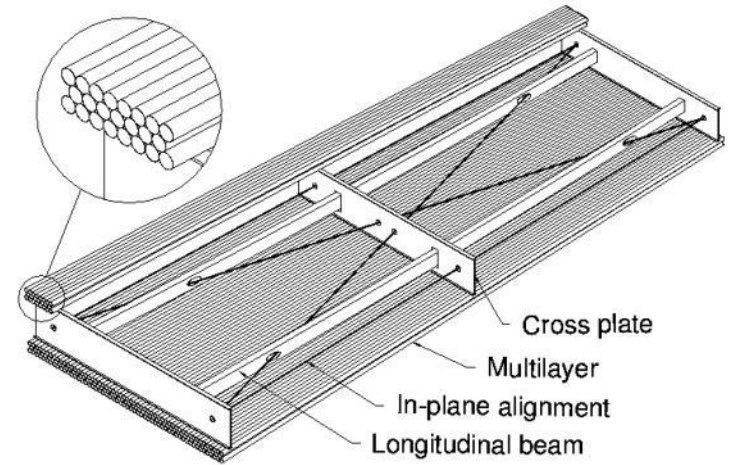

# Detector Systems

# **CERN Neutrino Gran Sasso**

**(CNGS)**

# CNGS

If neutrinos have mass:

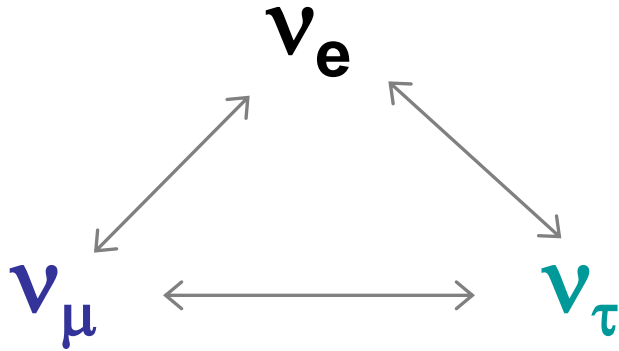

Muon neutrinos produced at CERN.  
See if tau neutrinos arrive in Italy.

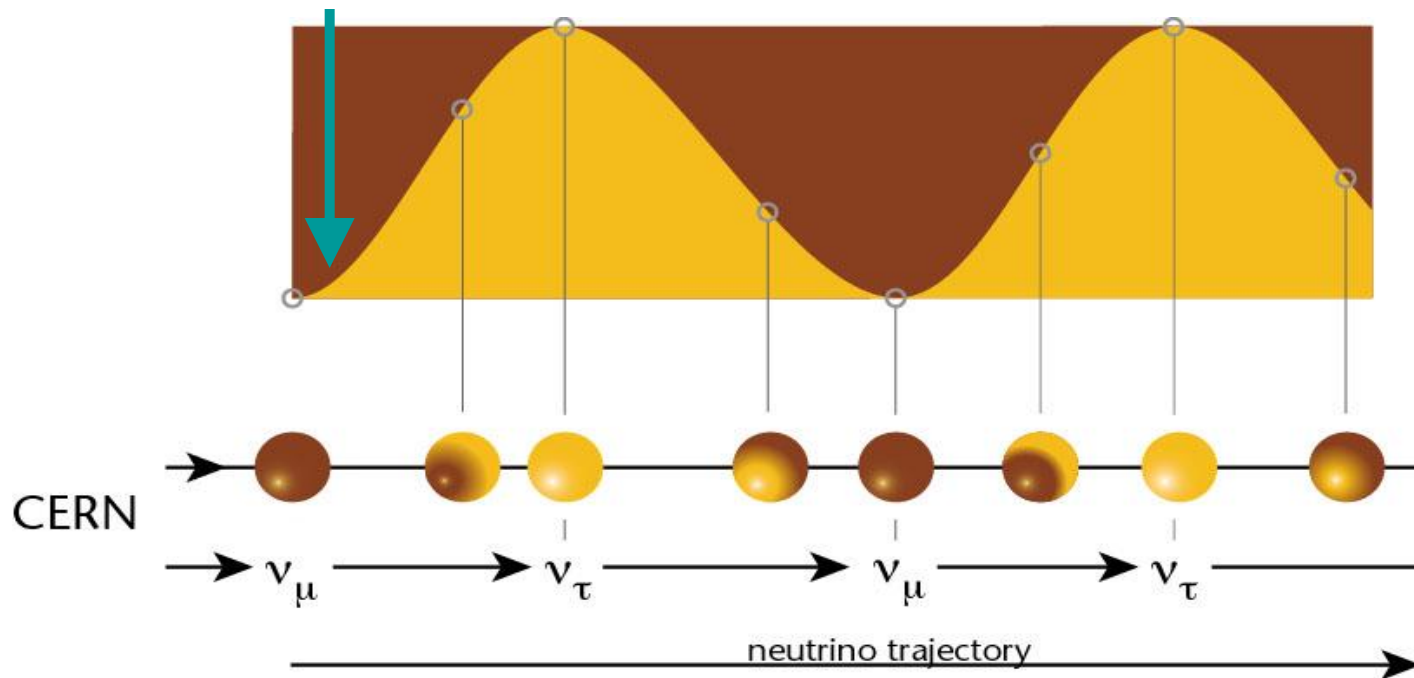

# CNGS Project

CNGS (CERN Neutrino Gran Sasso)

- A long base-line neutrino beam facility (732km)
- send  $\nu_{\mu}$  beam produced at CERN
- detect  $\nu_{\tau}$  appearance in OPERA experiment at Gran Sasso



➔ direct proof of  $\nu_{\mu}$  -  $\nu_{\tau}$  oscillation (appearance experiment)

# CNGS

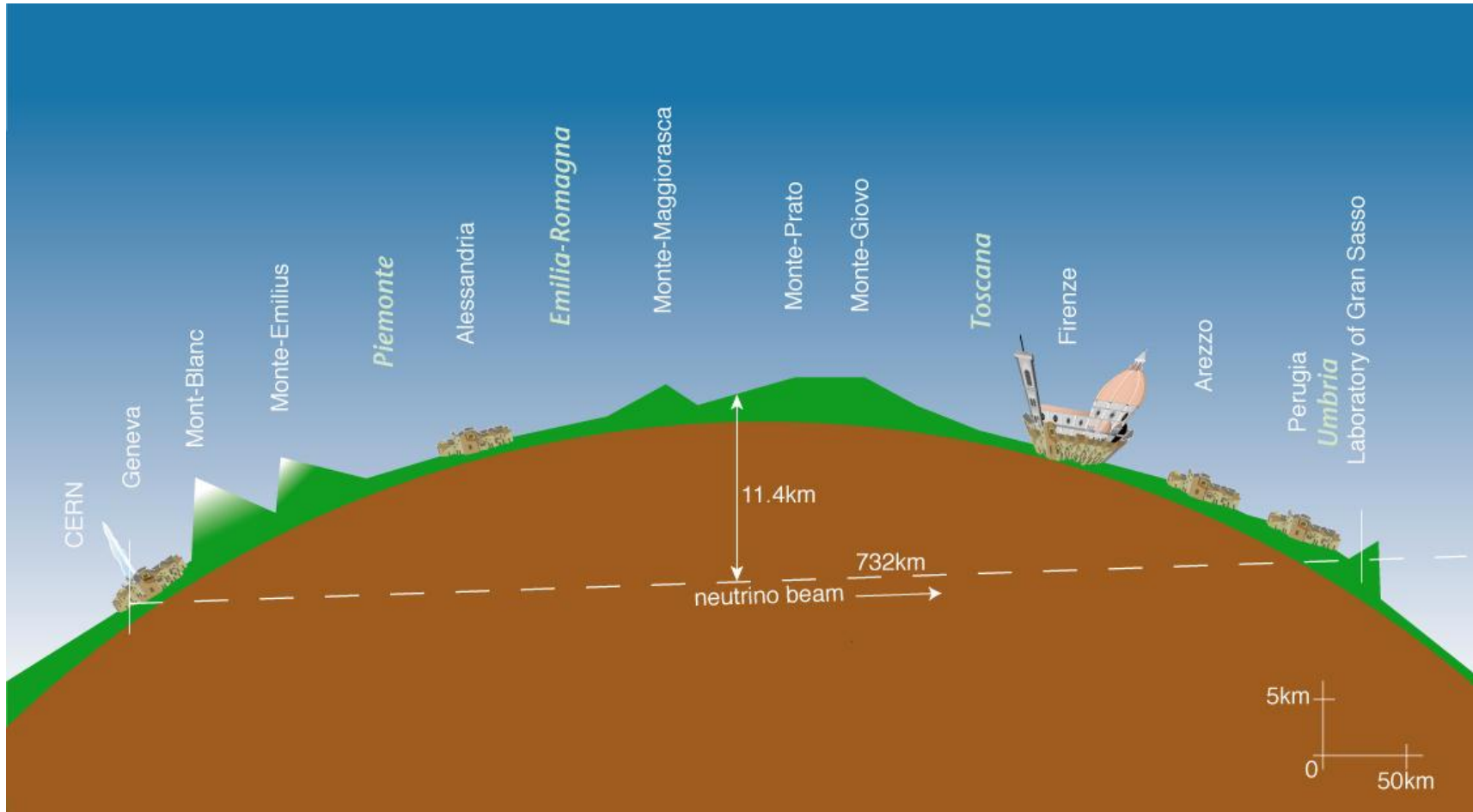

# CNGS

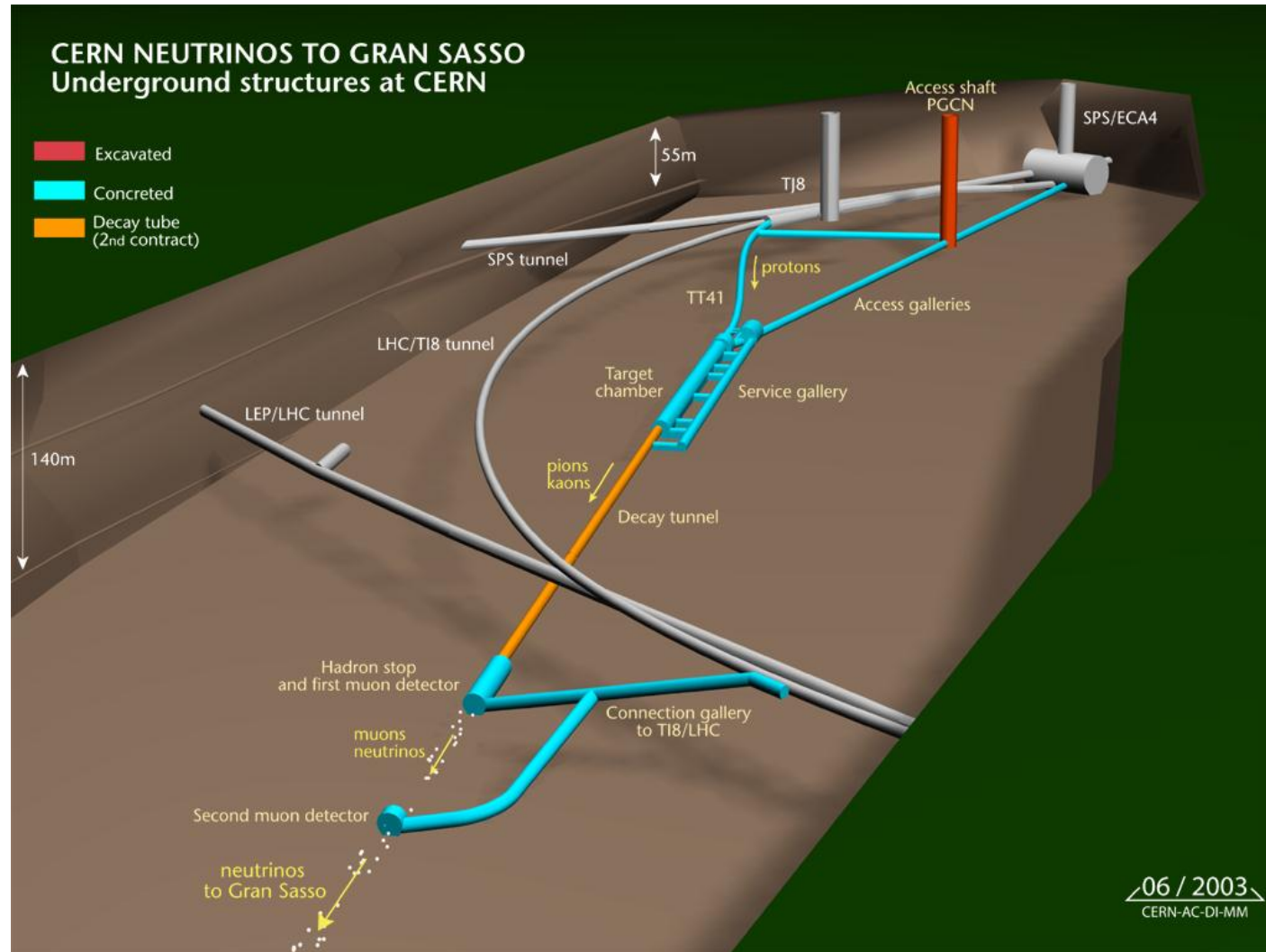

# CNGS

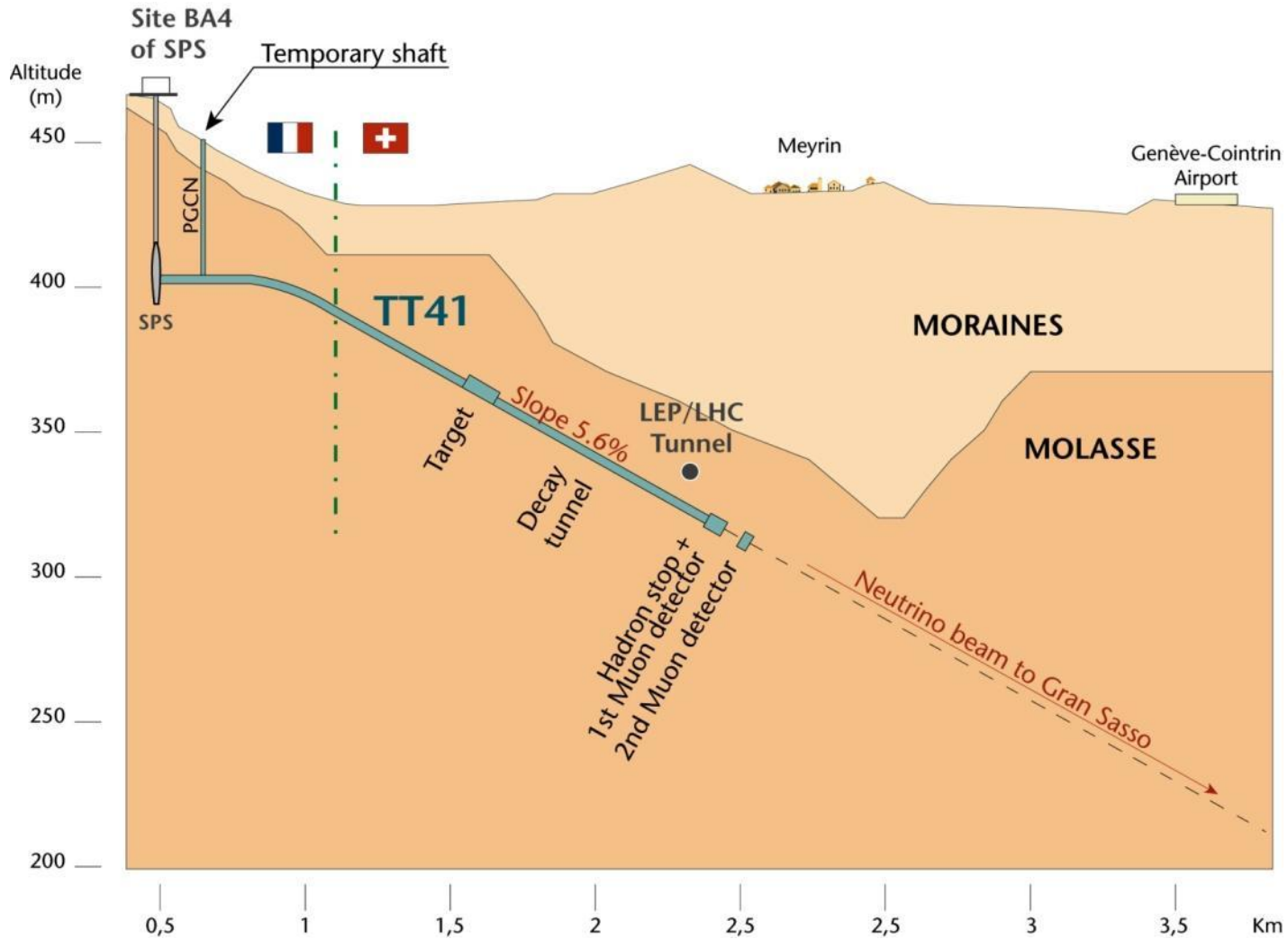



# Radial Distribution of the $\nu_\mu$ -Beam at GS

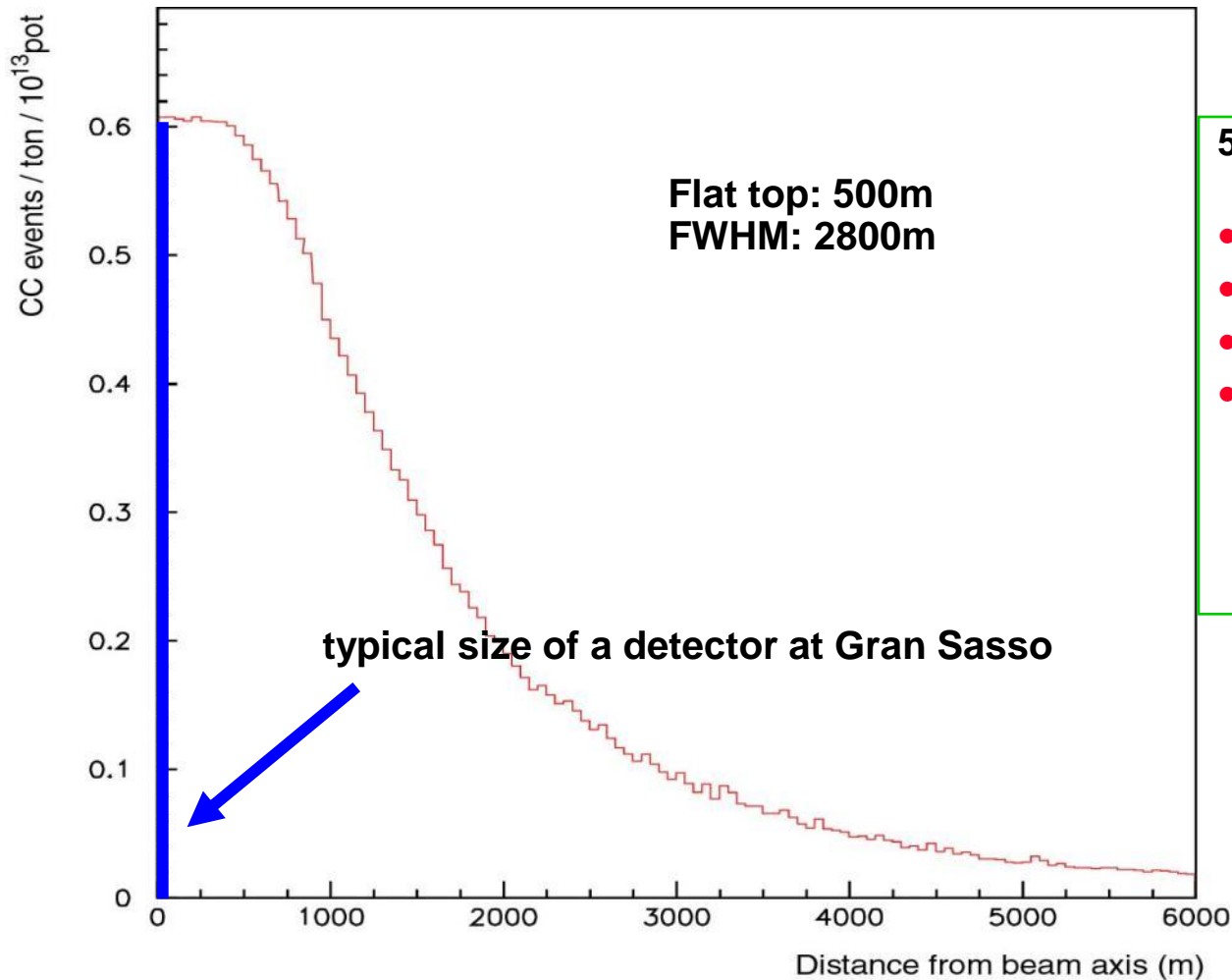

5 years CNGS operation, 1800 tons target:

- 30000 neutrino interactions
- $\sim 150$   $\nu_\tau$  interactions
- $\sim 15$   $\nu_\tau$  identified
- $< 1$  event of background

# Neutrinos at CNGS: Some Numbers

For 1 year of CNGS operation, we expect:

protons on target	$2 \times 10^{19}$	
pions / kaons at entrance to decay tunnel		$3 \times 10^{19}$
$\nu_{\mu}$ in direction of Gran Sasso	$10^{19}$	
$\nu_{\mu}$ in 100 m <sup>2</sup> at Gran Sasso	$3 \times 10^{14}$	
$N_{\mu}$ events per day in OPERA	$\approx 2500$	
$N_{\tau}$ events (from oscillation)	$\approx 2$	

# Opera Experiment at Gran Sasso

## Basic unit: brick

56 Pb sheets + 56 photographic films (emulsion sheets)

Lead plates: massive target

Emulsions: micrometric precision

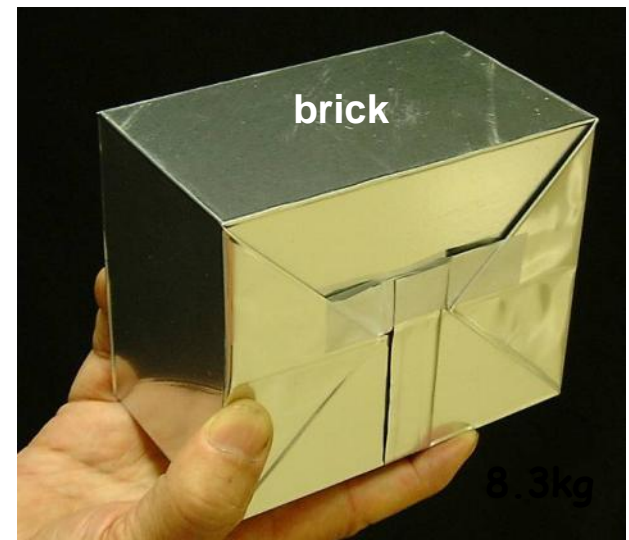
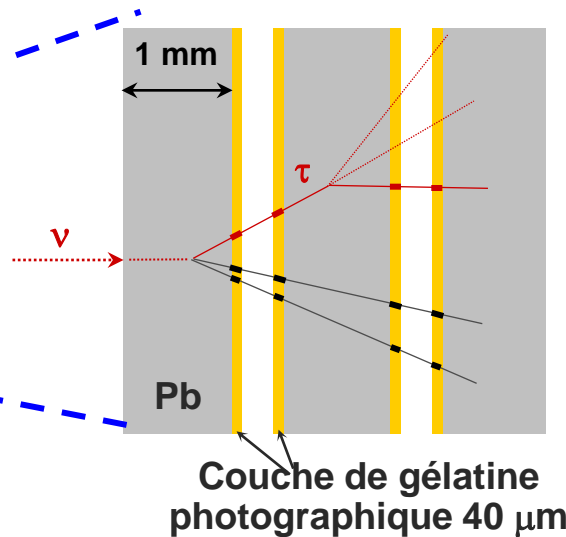
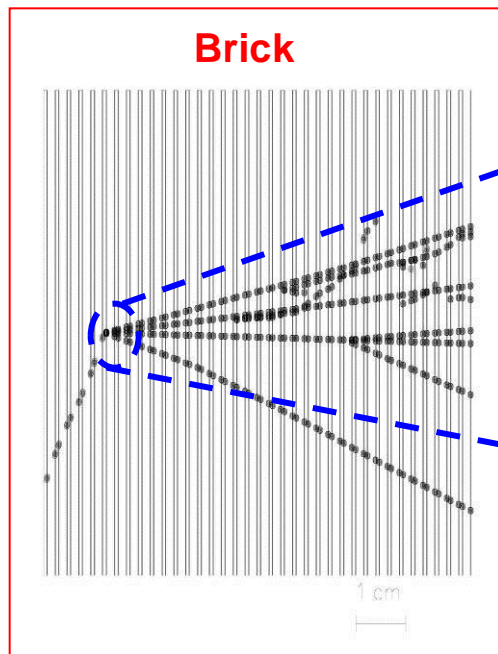

10.2 x 12.7 x 7.5 cm<sup>3</sup>

# Opera Experiment at Gran Sasso



31 target planes / supermodule In total: 206336 bricks, 1766 ton

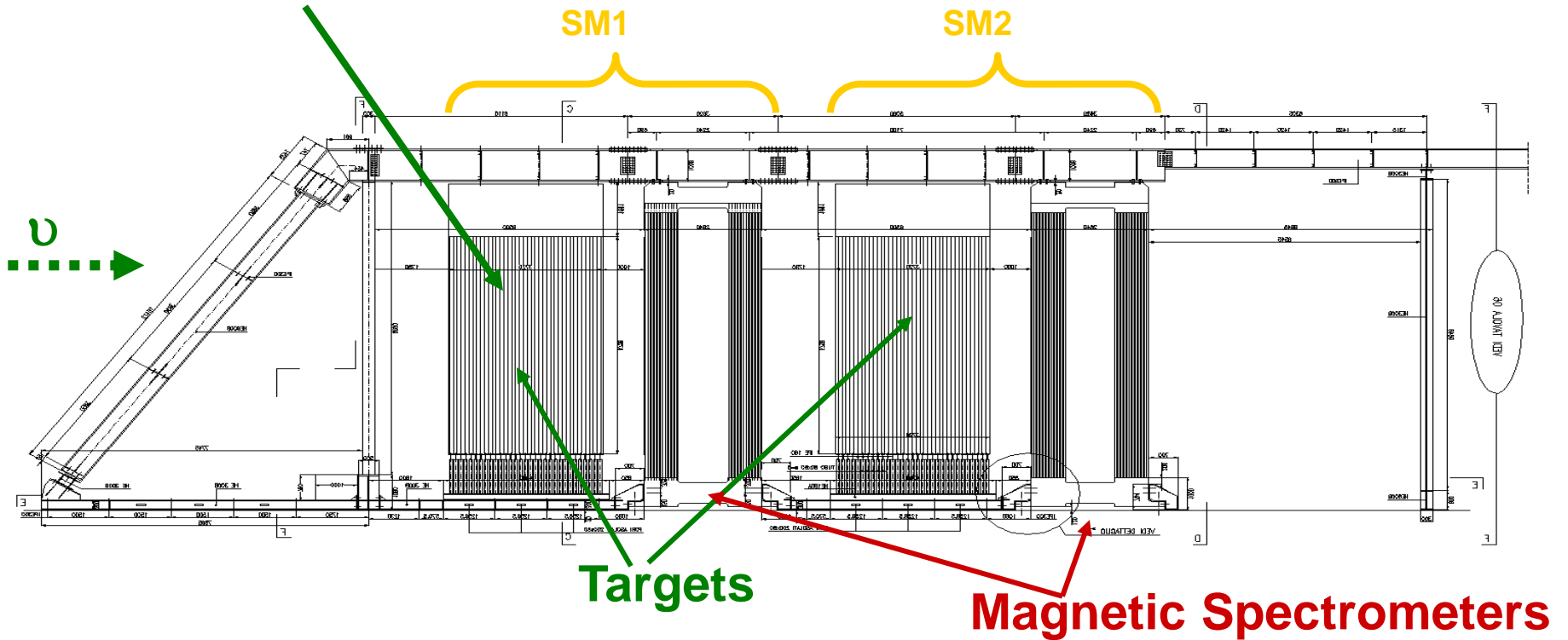

First observation of CNGS beam neutrinos : August 18<sup>th</sup>, 2006

# Opera Experiment at Gran Sasso



Second Super-module



Scintillator planes 5900 m<sup>2</sup>  
8064 7m long drift tubes

Details of the first spectrometer

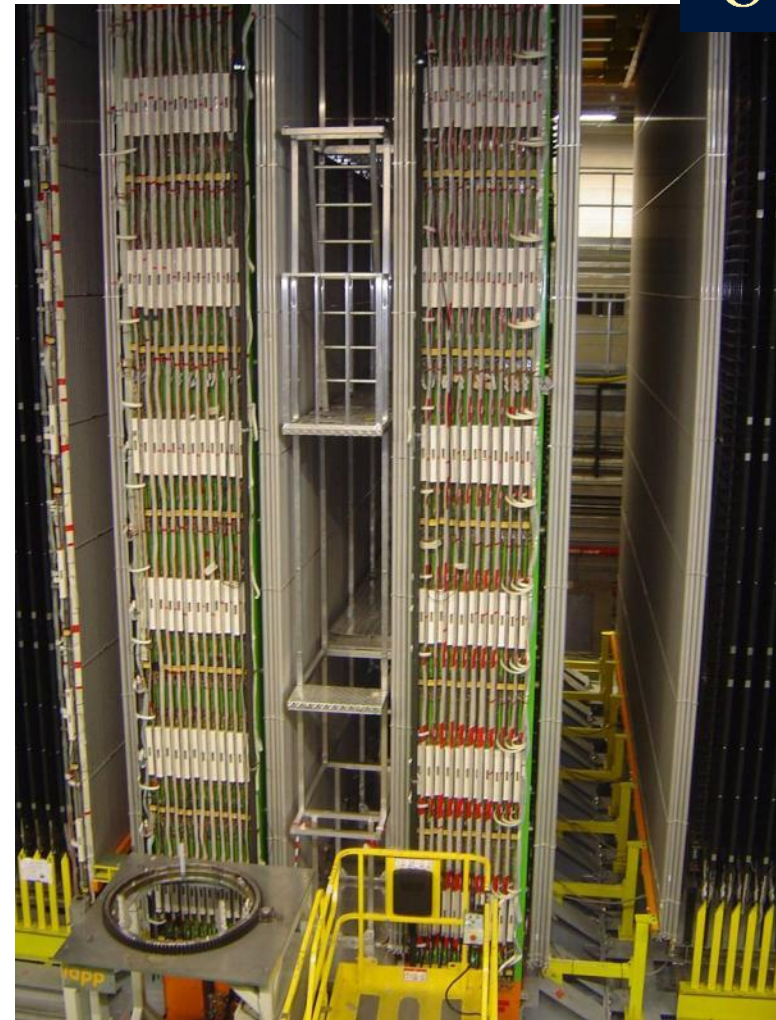

3050 m<sup>2</sup> Resistive Plate Counters  
2000 tons of iron for the two magnets

# Opera Experiment at Gran Sasso

The Brick Manipulator System (BMS) prototype:  
a lot of fun for children and adults !

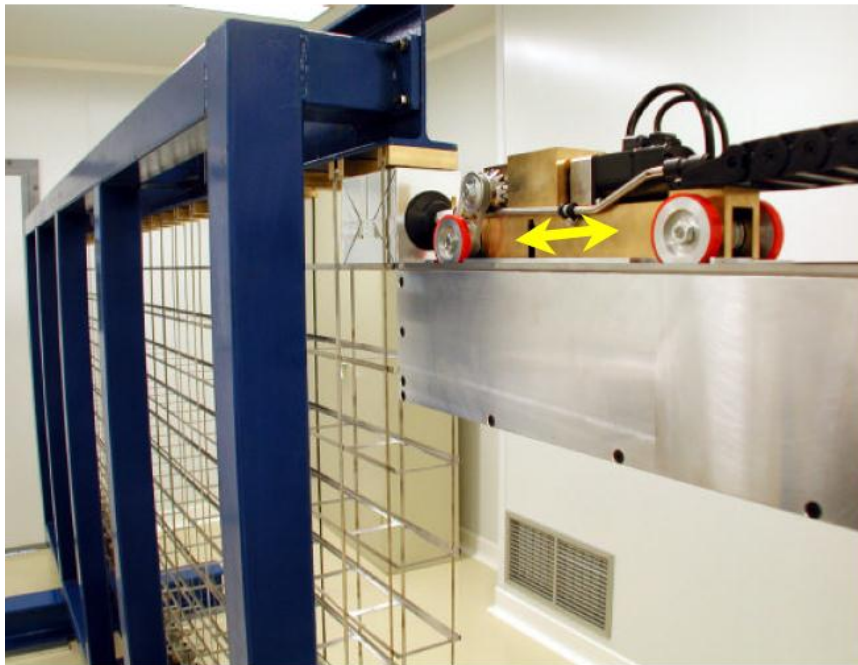
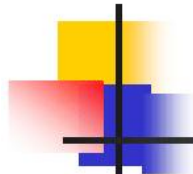

Tests with the prototype wall

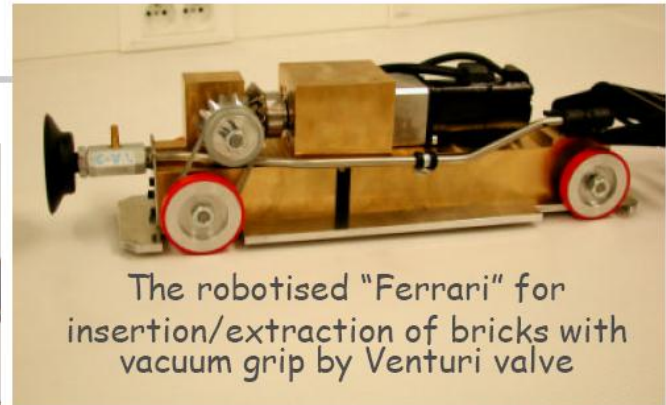

The robotised "Ferrari" for  
insertion/extraction of bricks with  
vacuum grip by Venturi valve



"Carousel" brick dispensing  
and storage system

# First Tau Candidate seen a few weeks ago !

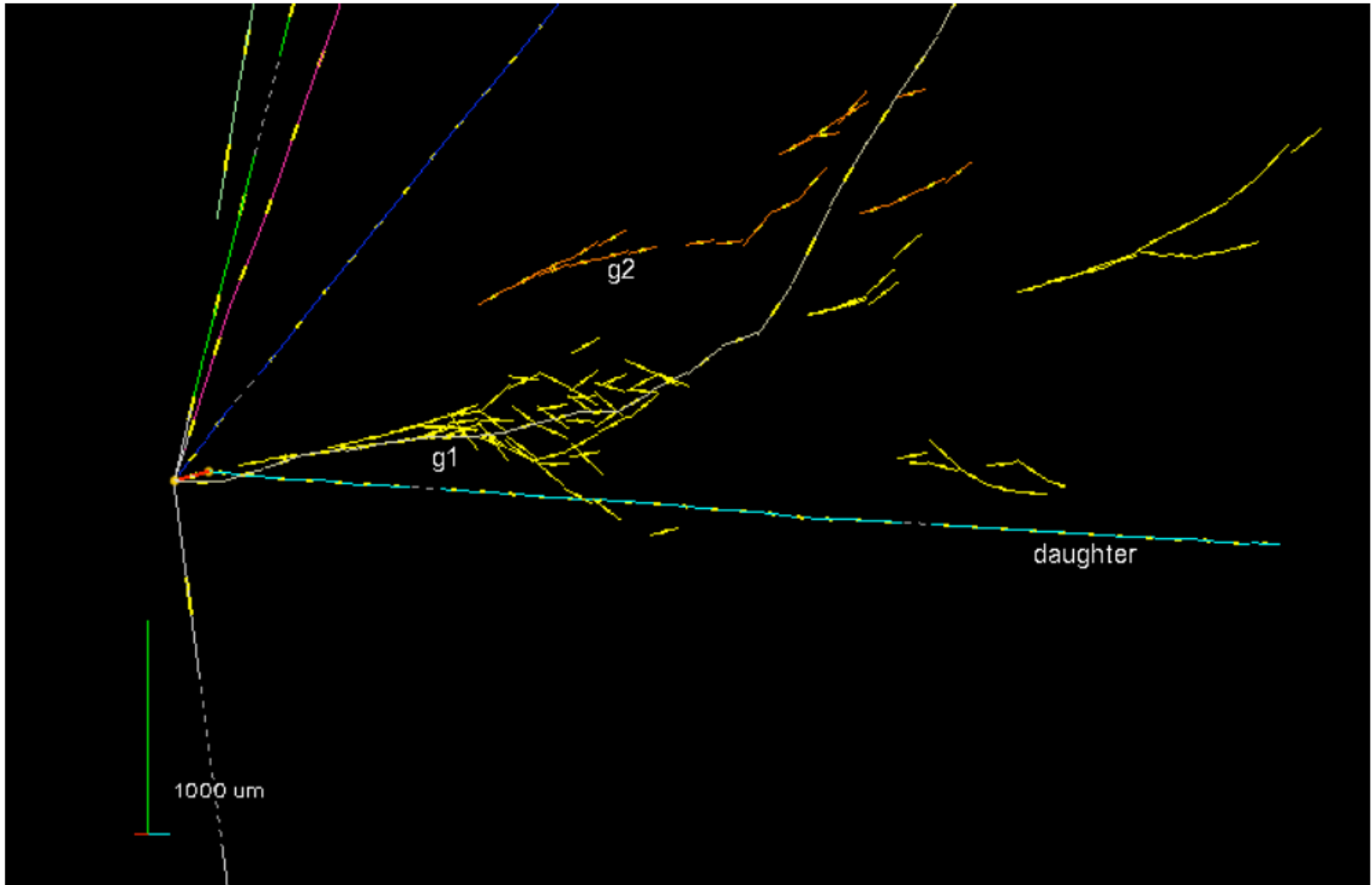

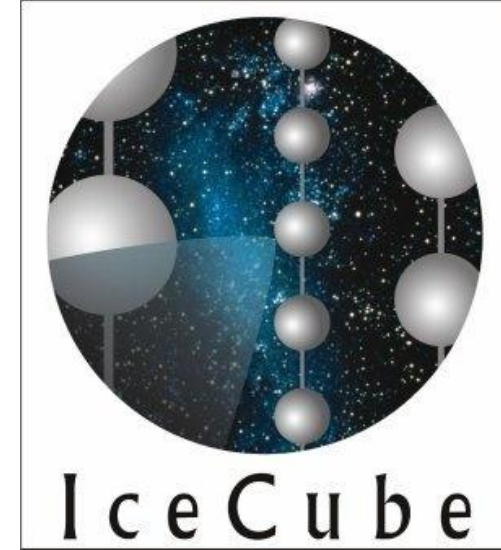
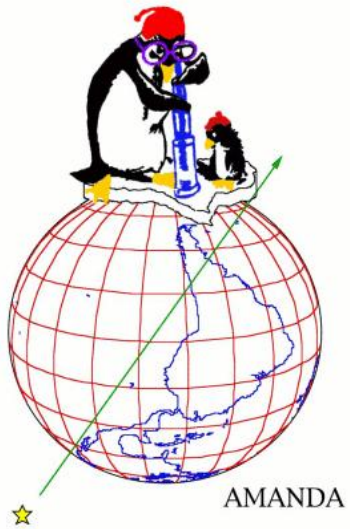

# AMANDA

Antarctic Muon And Neutrino Detector Array



# AMANDA



South Pole



# AMANDA

## AMANDA-II

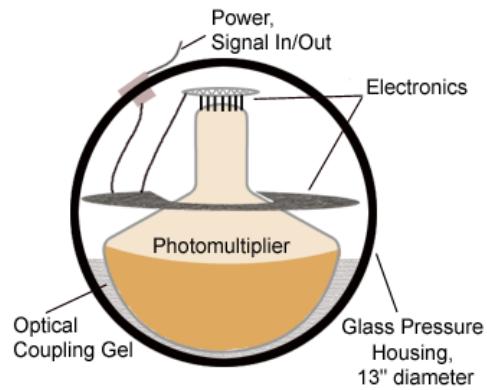
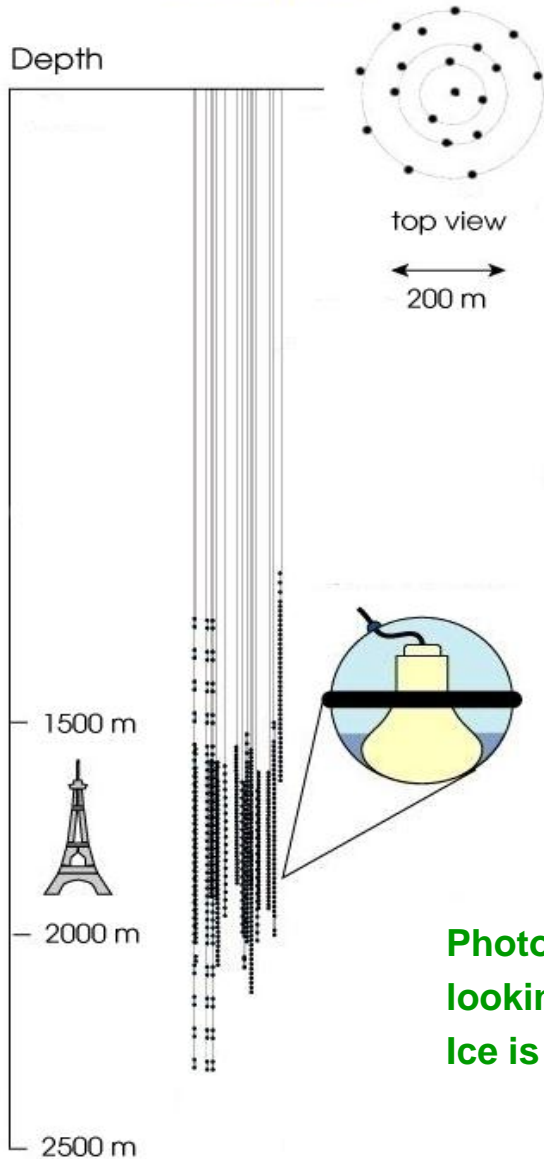

**Photomultipliers in the Ice,  
looking downwards.  
Ice is the detecting medium.**



# AMANDA

Look for upwards going Muons from Neutrino Interactions.  
Cherckov Light propagating through the ice.

→ Find neutrino point sources in the universe !

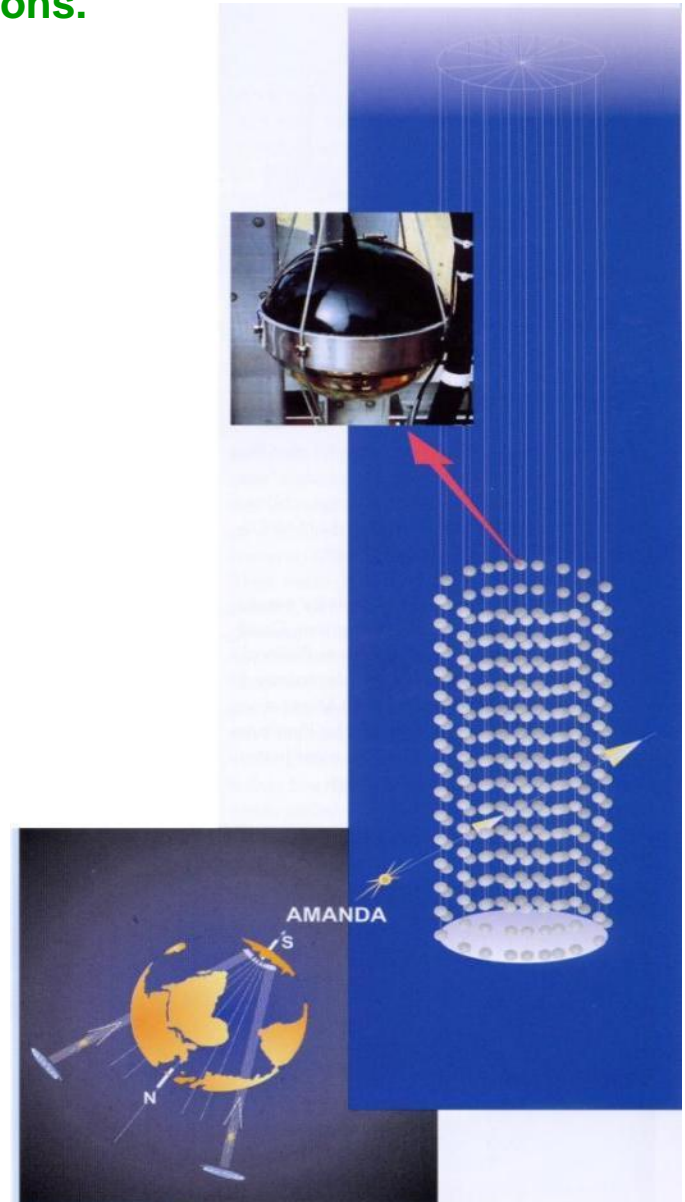
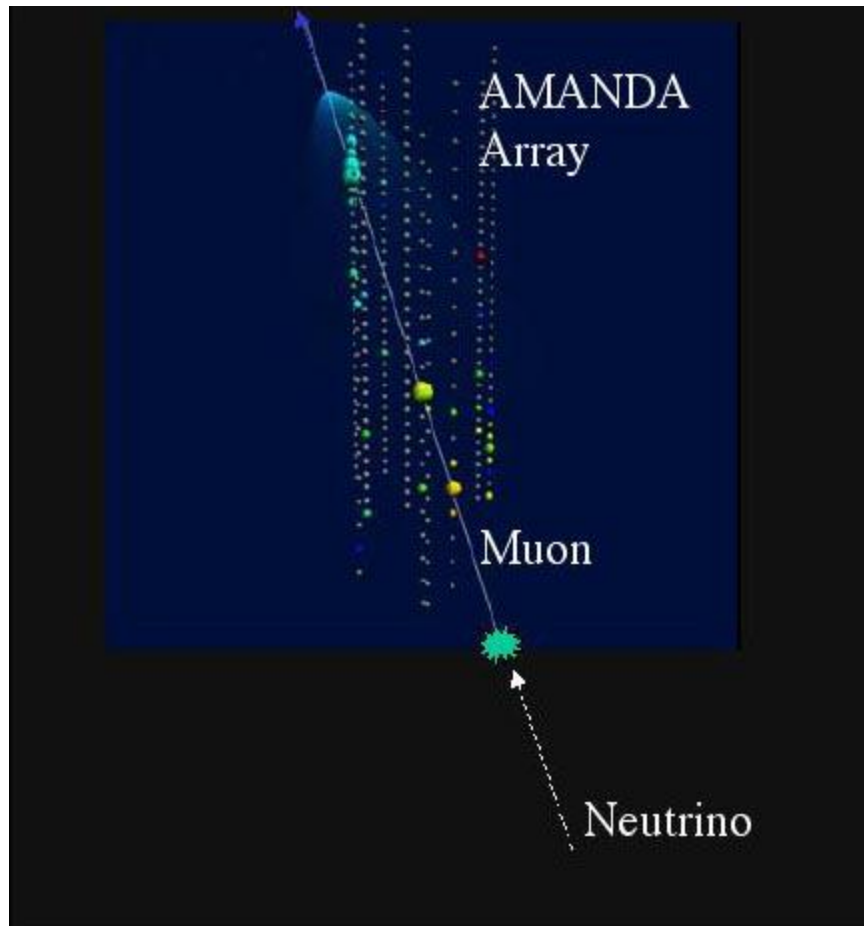

# AMANDA

## Event Display

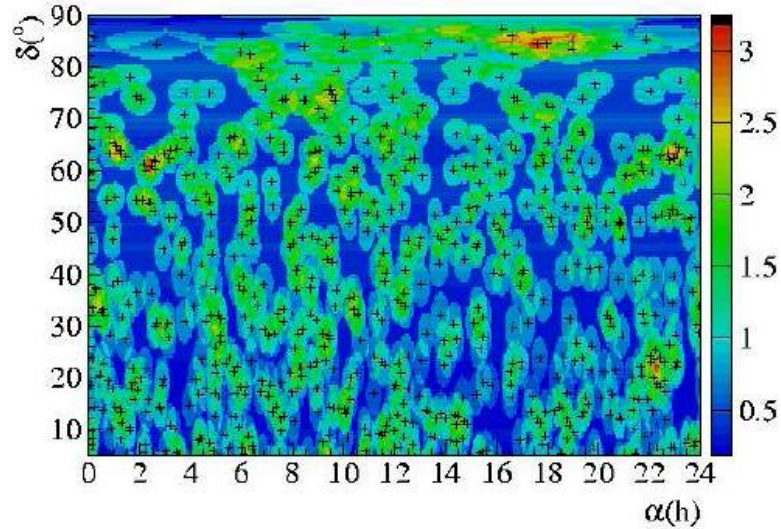
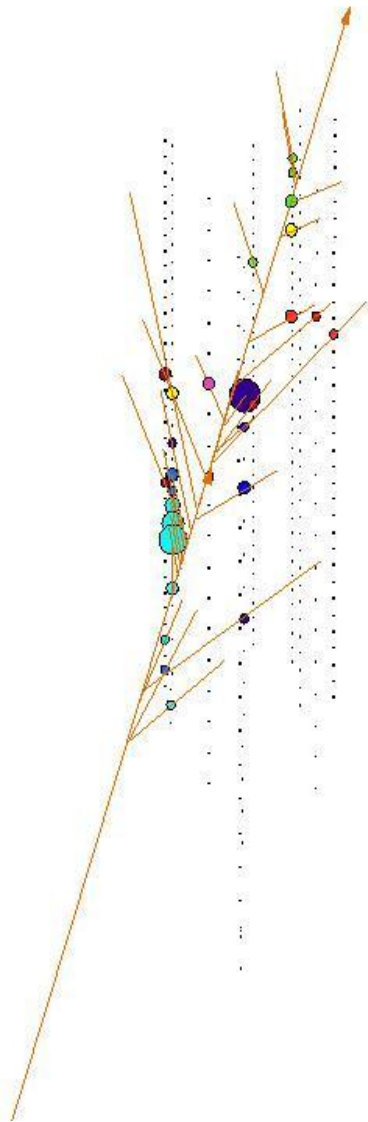

**Up to now: No significant point sources but just neutrinos from cosmic ray interactions in the atmosphere were found .**

**→ Ice Cube for more statistics !**

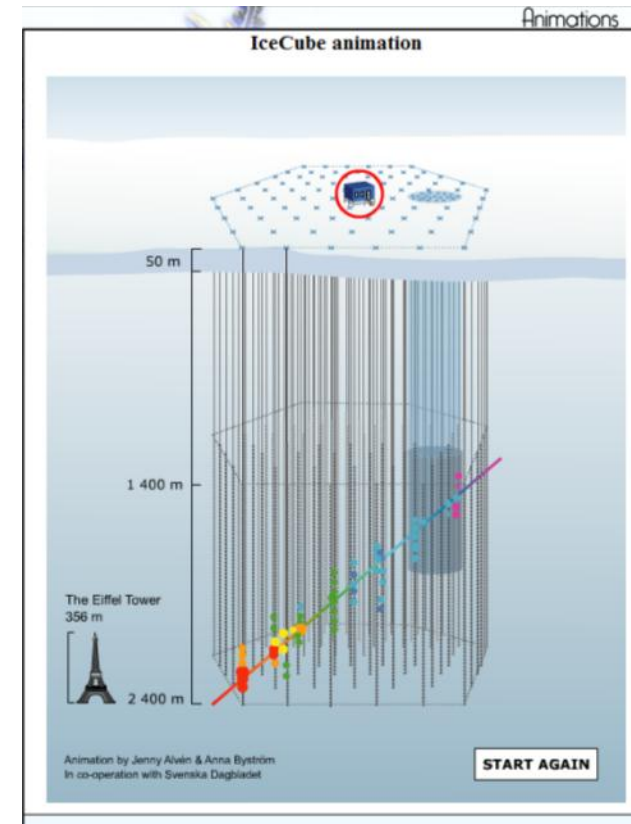



# AMS

## Alpha **M**agnetic **S**pectrometer

Try to find Antimatter in the primary cosmic rays.  
Study cosmic ray composition etc. etc.

# AMS

Will be installed on the space station.

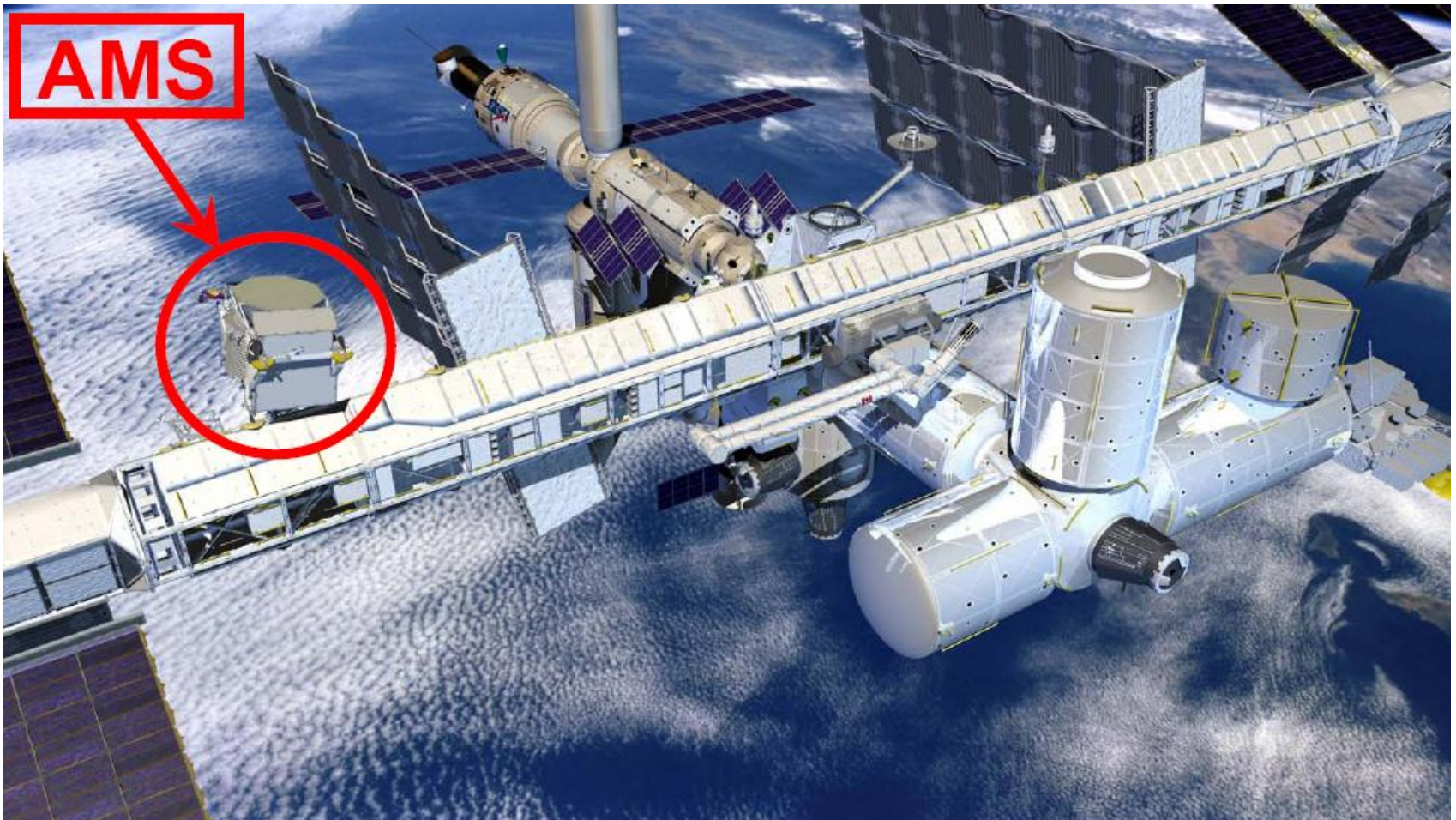

# AMS

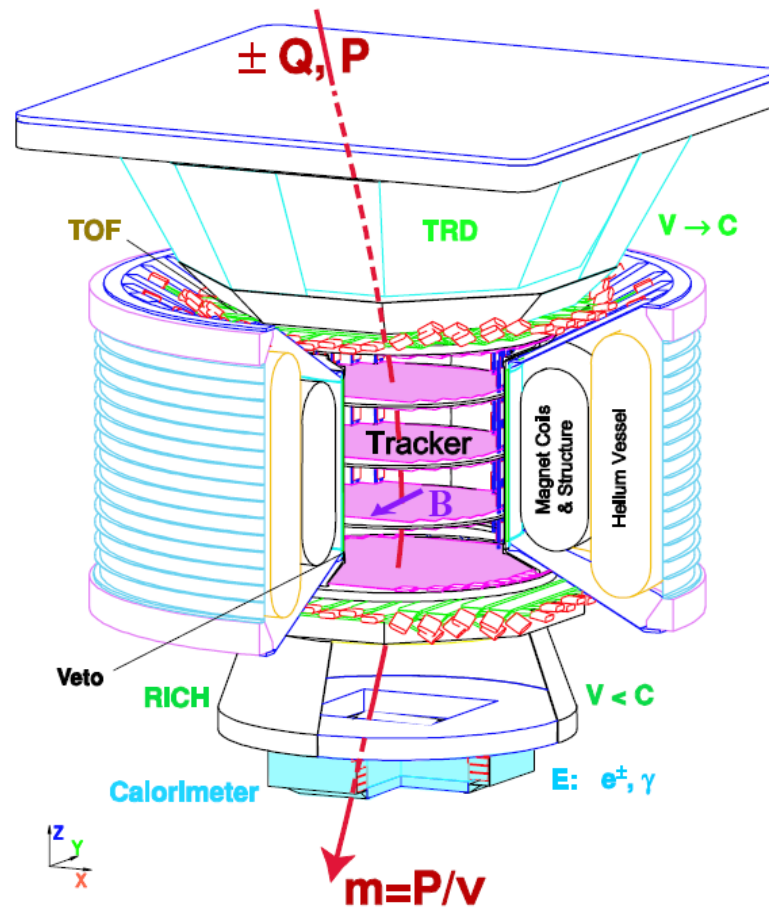

# AMS

