



irfu



Mechanics in UHF solenoids.

« The challenge of a 40 T full SC magnet »

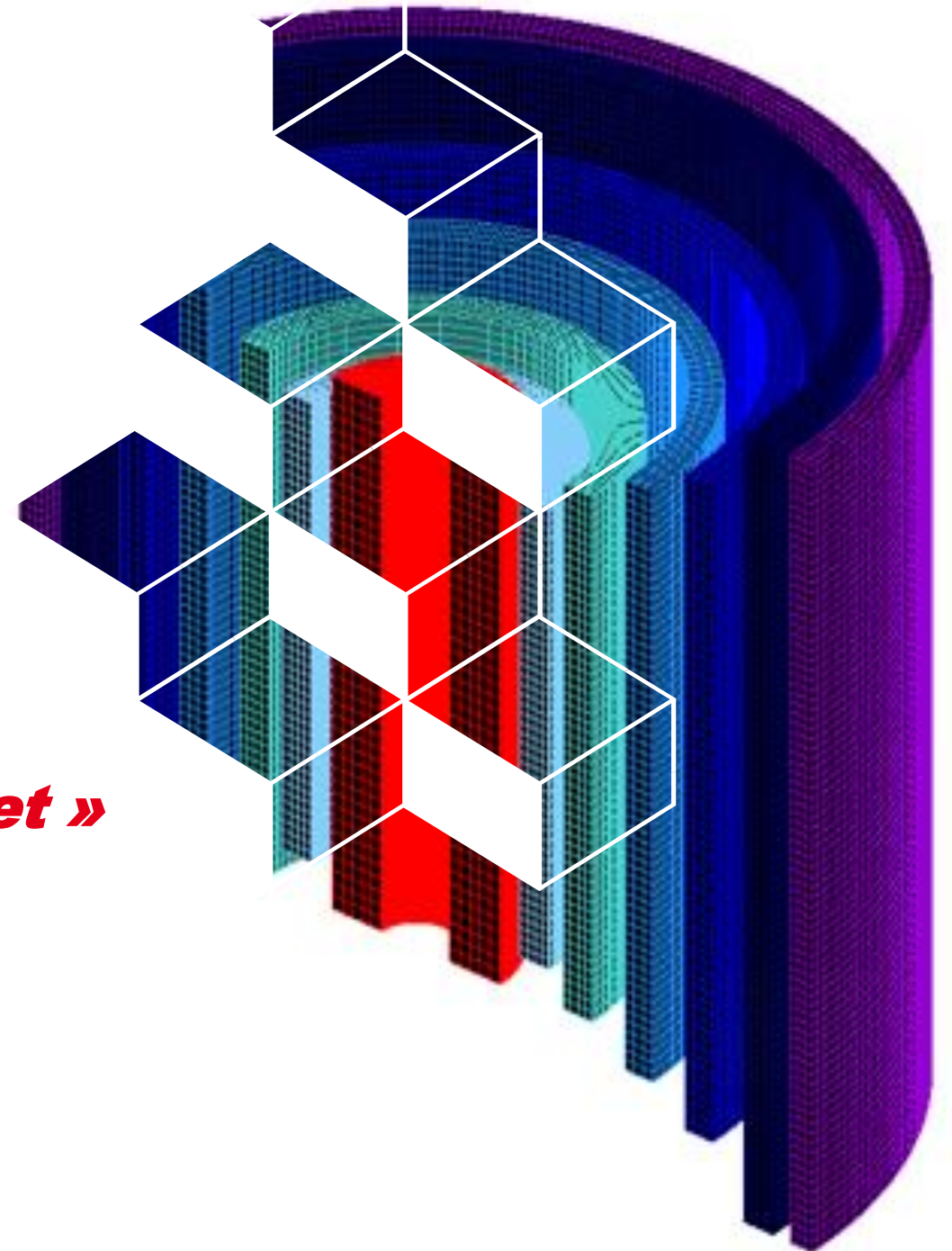

Thibault de CHABANNES
Philippe FAZILLEAU

CEA – Saclay
DRF/IRFU/DACM/LEAS

thibault.dechabanneslapalice@cea.fr
philippe.fazilleau@cea.fr

High magnetic field magnet

Full resistive magnet

42T (CHMFL)



42,02T resistive magnet of the High Magnetic Field Laboratory of Hefei Institutes of Physical Science, Chinese Academy of Sciences (CHMFL) – 2017

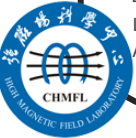

Hybrid Resistive / LTS user magnet

43T(CNRS)/ 45T (NHMFL)

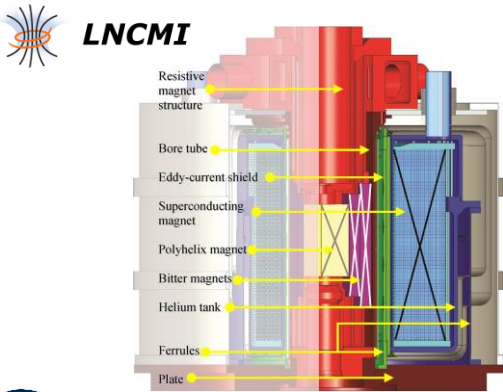

LNCMI

43T Hybrid magnet of the Laboratoire National des Champs Magnétiques Intenses (LNCMI-CNRS)



Full SC LTS/ HTS magnet

40T (FASUM/NHMFL)



40T Full superconducting magnet FASUM - LNCMI & CEA – 2021



OXFORD INSTRUMENTS NANOSCIENCE



Full SC HTS magnet

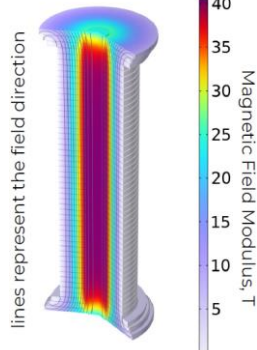

40T (Muon Collider)



lines represent the field direction

Magnetic Field Modulus, T

40T HTS solenoid of the MuonCollider project - 2021.





Introduction

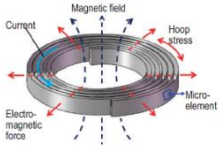

High magnetic field challenge

Induces high Lorentz forces
Volumic force $f = j \times B \propto B^2$
At constant volume of conductor,
from 10 T to 40 T
force density increases by 16



With the use of HTS ReBCO material.
Special issue of **screening currents**

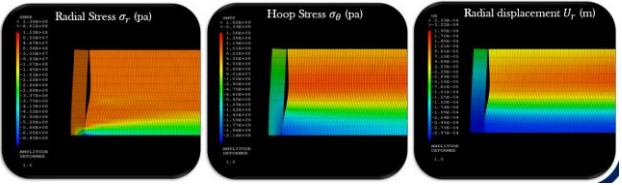

Configuration of single or nested solenoids

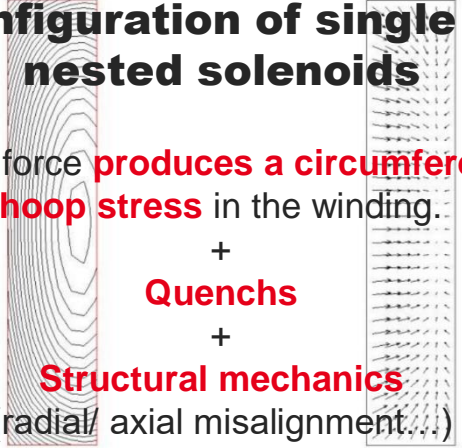

Radial force **produces a circumferential hoop stress** in the winding.
+
Quenches
+
Structural mechanics
(radial/ axial misalignment...)

Major issue of mechanics in UHF solenoids

ReBCO tapes, a sensitive material

- **Multi-layered architecture**

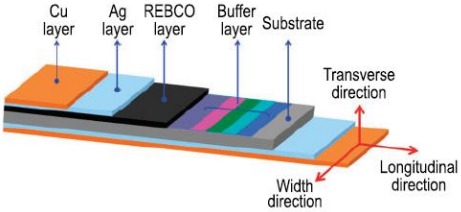

- **Longitudinal mechanical properties**

- Reversibly degrades the critical current below an irreversible strain limit ($\epsilon_{irr} \sim 0.4\%$), after which degradation becomes permanent due to ceramic layer fracturing,

- **Transverse mechanical properties and delamination**

- The laminated structure creates vulnerability to **transverse delamination**.
- Mechanical delamination strength at **77 K** ranges around **30 MPa**.

- **Fatigue and High-Cycle Loading**

- **Screening Current effects**

- Produce significant field reduction and non-uniform field distributions.
- Shear stresses due to strong reverse forces.
- local overstressing and potential plastic deformation
- Tilting effect.

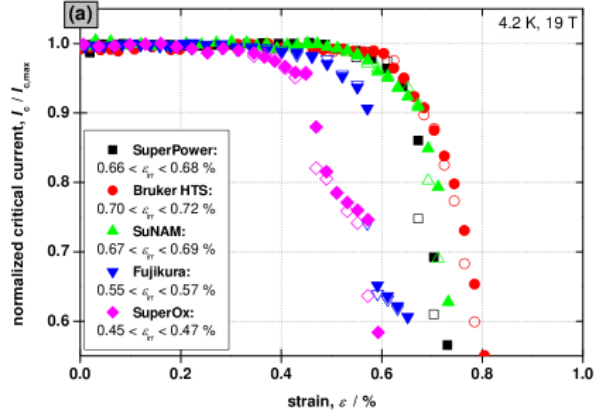

Barth (2015)



Zhou (2023)

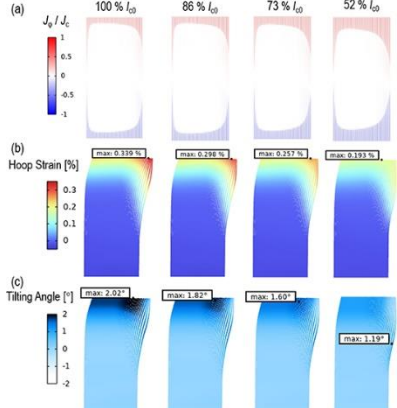
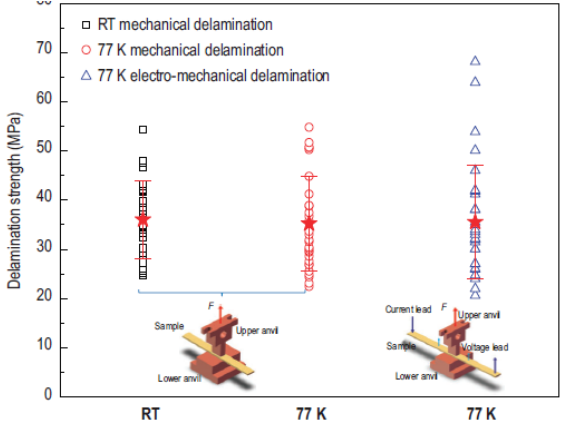

Yan (2021)



High magnetic field program at CEA



NOUGAT 32.5 T



14.5 T HTS
+
18 T resistive coils

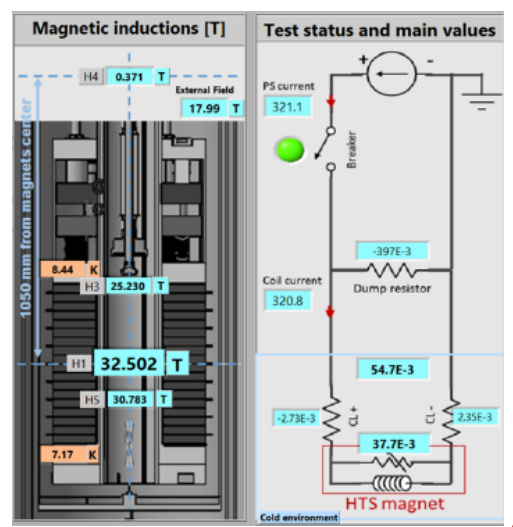

SuperEMFL SC 32 T+/40 T+ 2020-2024

11 europeans partners (academic/industry), total budget 2.9 M€
Designs of single and nested coils all sc 40 T+ magnets
Prototypes of nested coils.



FASUM 40 T 2022-2027



3 french partners (CEA/LNCMI-G,UGA)
 Total budget 3.4 M€
Fabrication of a 40 T all sc user magnet
 Hybrid LTS/HTS magnet



50 T Insert 2025-2027

Internal CEA fundings





“From 32.5T to 40T the mechanical issues of LTS / HTS hybrid magnet”

■ HTS insert

- Single stack vs nested stack coils
- Mechanical modelling
- Screening-current issues
- Solutions for mechanical challenges

■ HTS/LTS mechanical interactions

- Interactions and mechanics during a quench : HTS/LTS
- Structural analysis of axial/lateral misalignment between HTS/LTS.
- Solutions for mechanical challenges

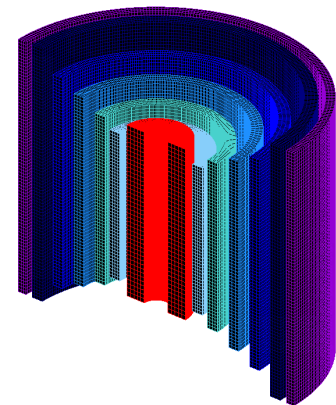



1. Mechanics in the HTS insert : the **superEMFL** and **FASUM 40T** projects

The superEMFL project : Nested coil vs Single coil

“Design of 32+ and 40+ T all-superconducting user magnets & fabrication of nested coil prototypes”

■ **Two main configurations due to commercial LTS outserts :** OXFORD INSTRUMENTS | NANOSCIENCE

- LTS outsert **150 mm Ø** / **Single stacked** pancake HTS solenoid
- LTS outsert **250 mm Ø** / **Nested stacked** pancakes HTS solenoid

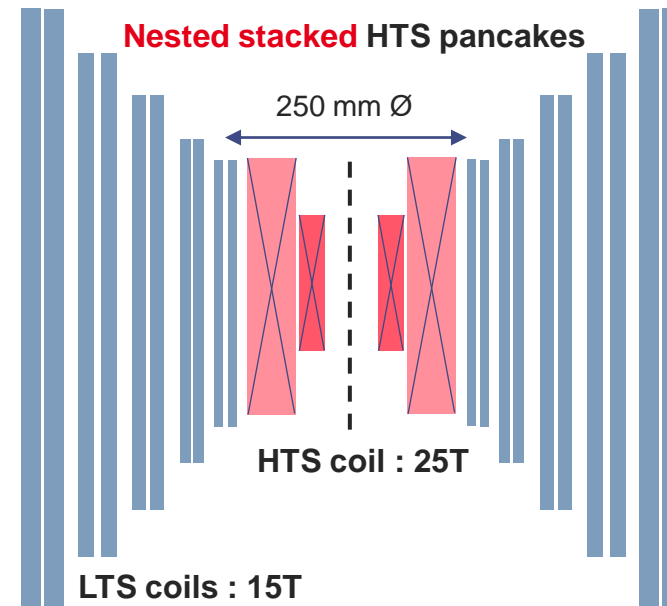
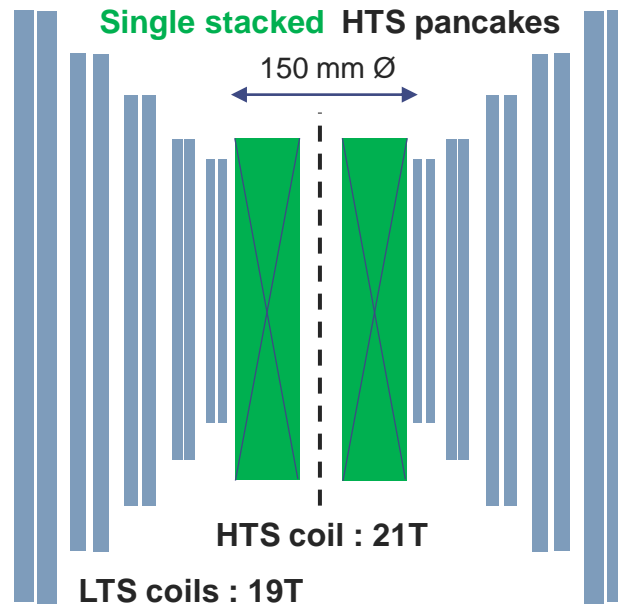

Which choice for the FASUM 40T project ?

□ Best **LTS economical** configuration : **Single HTS coil**

□ Best **HTS mechanical** configuration : **Nested HTS coil**

A quick regard : the HTS pancake

I or NI winding ?

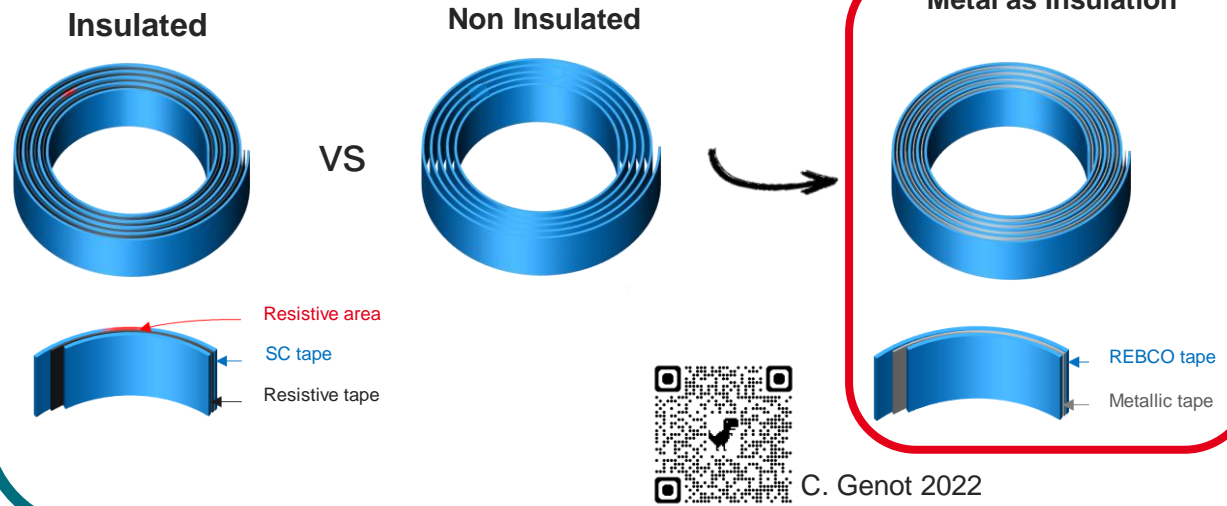

The Rct compromise

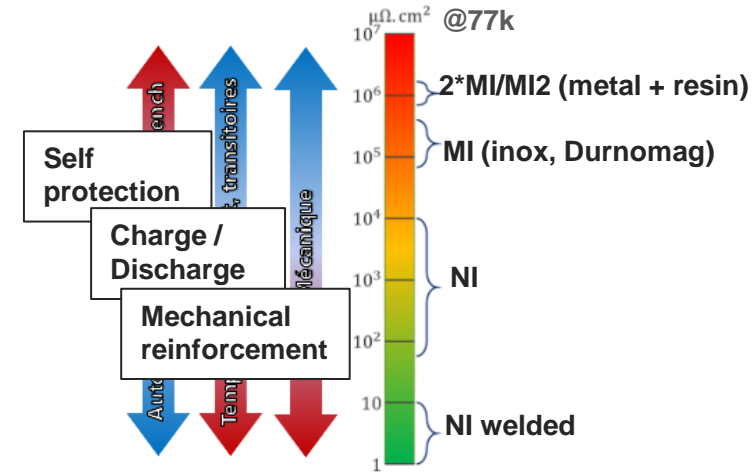

Courtesy P. Fazilleau - HDR defense

■ Choice at CEA of the intermediate solution of MI technology

- Mechanical reinforcement + pre-winding & over-banding with Durnomag® stainless steel tape
- Good compromise with charge/discharge time constant
- Good compromise with self protection.

■ Example of severe mechanical issue : the MIT H800 NI nested coil

- Mechanical damage during quench due to strong torques due to nested coils coupling and radial current due to NI configuration.
- Using the MI technology we are willing to avoid these particularly high mechanical issues.

Broken preload bolt due to strong torque on coil n°1 following H800 magnet quench.

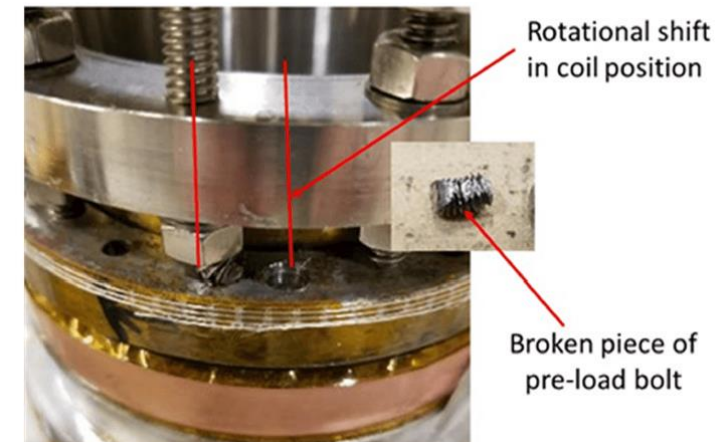

Philip. C 2019



SuperEMFL : HTS single coil results

Magnetic optimised designs of SuperEMFL single coil HTS insert

	<i>Basic Design</i>	<i>High Field</i>	<i>High Volume</i>	
Ref.	<i>S1</i>	<i>S2a</i>	<i>S2b</i>	<i>S2c</i>
Design led by	Mechanics	Mechanics	Mechanics	Mechanics
Geometry				
Internal diameter (winding)	40 mm	30 mm	40 mm	50 mm
External diameter (winding+ob)	122.8 mm	121.2 mm	122.8 mm	125.4 mm
Number of double-pancakes	25	25	25	25
Turns per pancake	380	420	380	360
Total length	4769.3 m	4888.6 m	4769.3 m	4959 m
Electrics				
SC conductor	THEVA APC			
Nominal current	293 A	303.9 A	308.9 A	283.3 A
Critical current	388.1 A	373.1 A	389.1 A	398.1 A
Current margin on load line	24.5 %	18.5 %	20.6 %	28.8 %
Magnetics				
Magnetic field at center (HTS alone)	21 T	24 T	22 T	19 T
Total Magnetic field at center	40 T	43 T	41 T	38 T
Mechanics				
Winding tension	100 MPa			
Turns of over-banding	50			
Maximal hoop stress	655.8 MPa	677.9 MPa	707.3 MPa	667.2 MPa
Non-thermal deformation (winding+field)	0.37 %	0.38 %	0.39 %	0.37 %

Parametric study (>10000 cases) with design criteria :

- Current margin > 25%
- Max Hoop-stress < 800 MPa
- Max elastic Hoop-strain < 0.4%

■ Conclusion of the study :

- ✓ Easy to fabricate
- ✗ High mechanical stress level due to high number of turns
- ✗ Possible loss of contact issue due to high number of turns
- ✗ Not possible to achieve 40T in a 50mm Ø

Elastic-plastic model of the REBCO coated conductor.

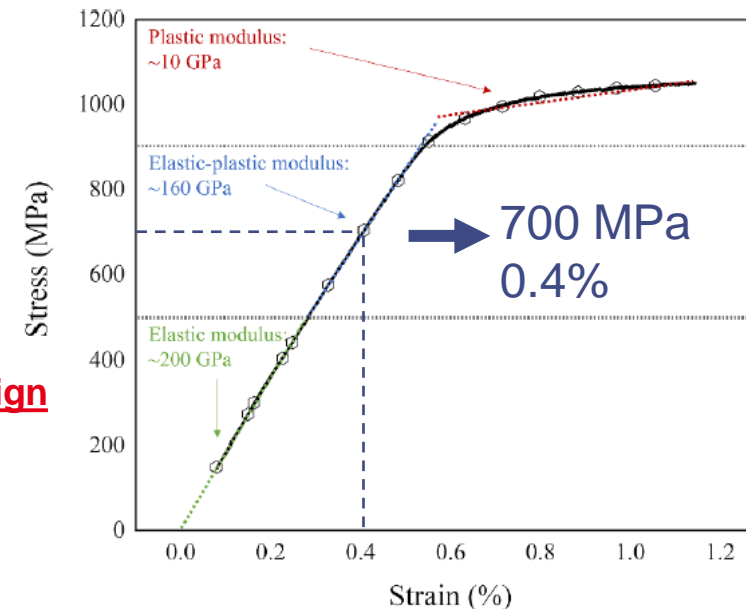

Bang 2024



SuperEMFL : HTS nested coil results

Magnetic optimised designs of SuperEMFL nested pancake coil

Name	Basic design		Low-stress design	High-Field Design	High-volume Design
Ref.	N1a	N1b	N2	N3	N4
Design led by	Mechanics				
Geometry					
Unit length	< 200 m	< 100 m	< 200 m	< 200 m	< 200 m
Internal diameter (winding)	50 mm	50 mm	50 mm	50 mm	70 mm
External diameter (windings+ob)	213.2 mm	167 mm	215.8 mm	215.8 m	214.8 mm
Gap between HTS1 and HTS2	15 mm	15 mm	10 mm	10 mm	10 mm
Number of double-pancakes HTS1	21	24	23	25	24
Turns per pancake HTS1	360	330	520	520	460
Number of double-pancakes HTS2	22	25	24	25	25
Turns per pancake HTS2	260	70	160	160	120
Maximal unit length	200 m	100 m	200 m	200 m	200 m
Total length	10 744 m	5934.8 m	12 051 m	13 470 m	11 961 m
Electrics					
SC conductor	THEVA APC				
Nominal current	231.2 A	339.7 A	208.8 A	238.3 A	239.1 A
Critical current	342.6 A	406.1 A	326.6 A	324.2 A	348.1 A
Current margin on load line	32.5 %	16.4 %	36.1 %	26.5 %	33.3 %
Magnetics					
Magnetic field at center (HTS alone)	25 T	25 T	25 T	29 T	25 T
Total magnetic field (HTS+LTS)	40 T	40 T	40 T	44 T	40 T
Mechanics					
Winding tension	100 MPa				
Turns of over-bending	50				
Maximal hoop stress HTS1	410.2 MPa	692.8 MPa	496.1 MPa	614.6 MPa	659.2 MPa
Non-thermal deformation (winding+field) HTS1	0.25 %	0.38 %	0.29 %	0.35 %	0.37 %
Maximal hoop stress HTS2	749.6 MPa	705.1 MPa	616.2 MPa	722.8 MPa	693.1 MPa
Non-thermal deformation (winding+field) HTS2	0.41 %	0.39 %	0.34 %	0.40 %	0.38 %

Courtesy of SuperEMFL design report of 32+T and 40+T nested coil HTS inserts

Low stress design

“Even though the Nested coil configuration can not be used for the FASUM project we are investigating nested coils dynamics with SuperEMFL prototypes...should be tested in the coming months.”

Conclusion of the study :

- ✓ Reduced of stress level : because of less number of turns better transfer of radial mechanical loads.
- ✓ Reduction of contact loss due to reduced number of turns per pancakes
- ✗ High magnetic coupling between coils.
- ✗ Need larger LTS internal diameter : 250 mm Ø

→ 50% more expensive.



Choice for the FASUM 40T project :

- ✗ Best HTS technical configuration : Nested coil LTS (15T – 150 mm Ø) / HTS (25T – 50 mm Ø)
- ✓ Best LTS economical configuration : Single coil LTS (19T – 140 mm Ø) / HTS (21T - 40 mm Ø)

FASUM 40 T : HTS single coil mechanical calculation

Choice of a single pancake design

Basic Design	
Ref.	S1
Design led by	Mechanics
Geometry	
Internal diameter (winding)	40 mm
External diameter (winding-ob)	122.8 mm
Number of double-pancakes	25
Turns per pancake	380
Total length	4769.3 m
Electrics	
SC conductor	
Nominal current	293 A
Critical current	388.1 A
Current margin on load line	24.5 %
Magnetics	
Magnetic field at center (HTS alone)	21 T
Total Magnetic field at center	40 T
Mechanics	
Winding tension	
Turns of over-banding	
Maximal hoop stress	655.8 MPa
Non-thermal deformation (winding+field)	0.37 %

2D pancake axisymmetric model

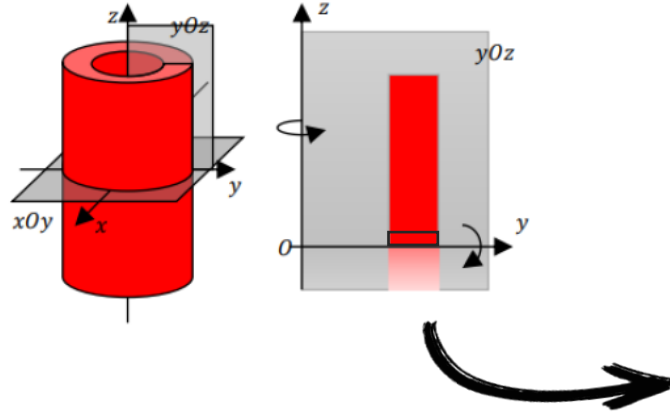

Meshing the co-winding with pre-tension

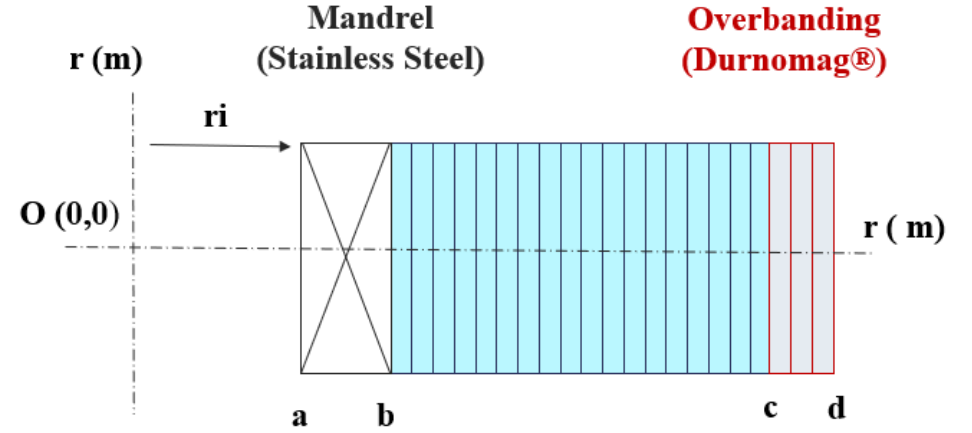

MI Winding (ReBCO + Durnomag®)

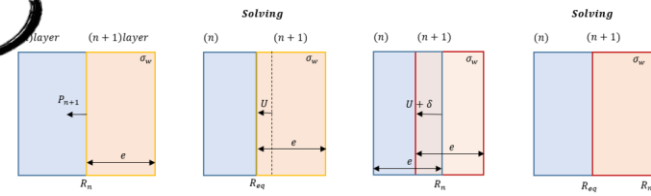

At step (n + 1)

External layer pressure

$$P_{n+1} = \frac{\sigma_w \cdot e}{R_n}$$

Virtual winding - stress (σ_w) shift

$$\delta = \frac{\sigma_w \cdot R_{eq}}{E}$$

CEA in house mechanical FEM

3 loadings

- Winding with pre-tension
- Cooling at 4K
- Lorentz force density due to energizing and external field (uniform or screening current density)

Pre-tensioned meshing

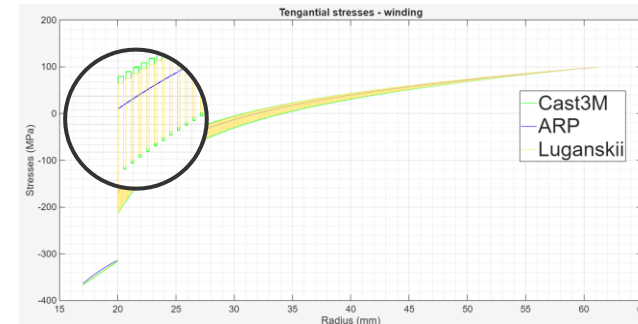

T. de Chabannes - 2024



FASUM 40 T : single coil mechanical calculation

2D axisymmetric pancake model : without screening current

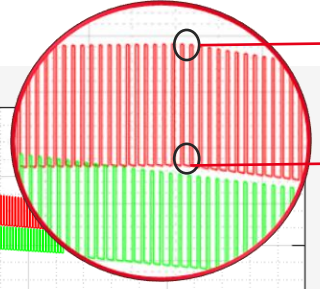
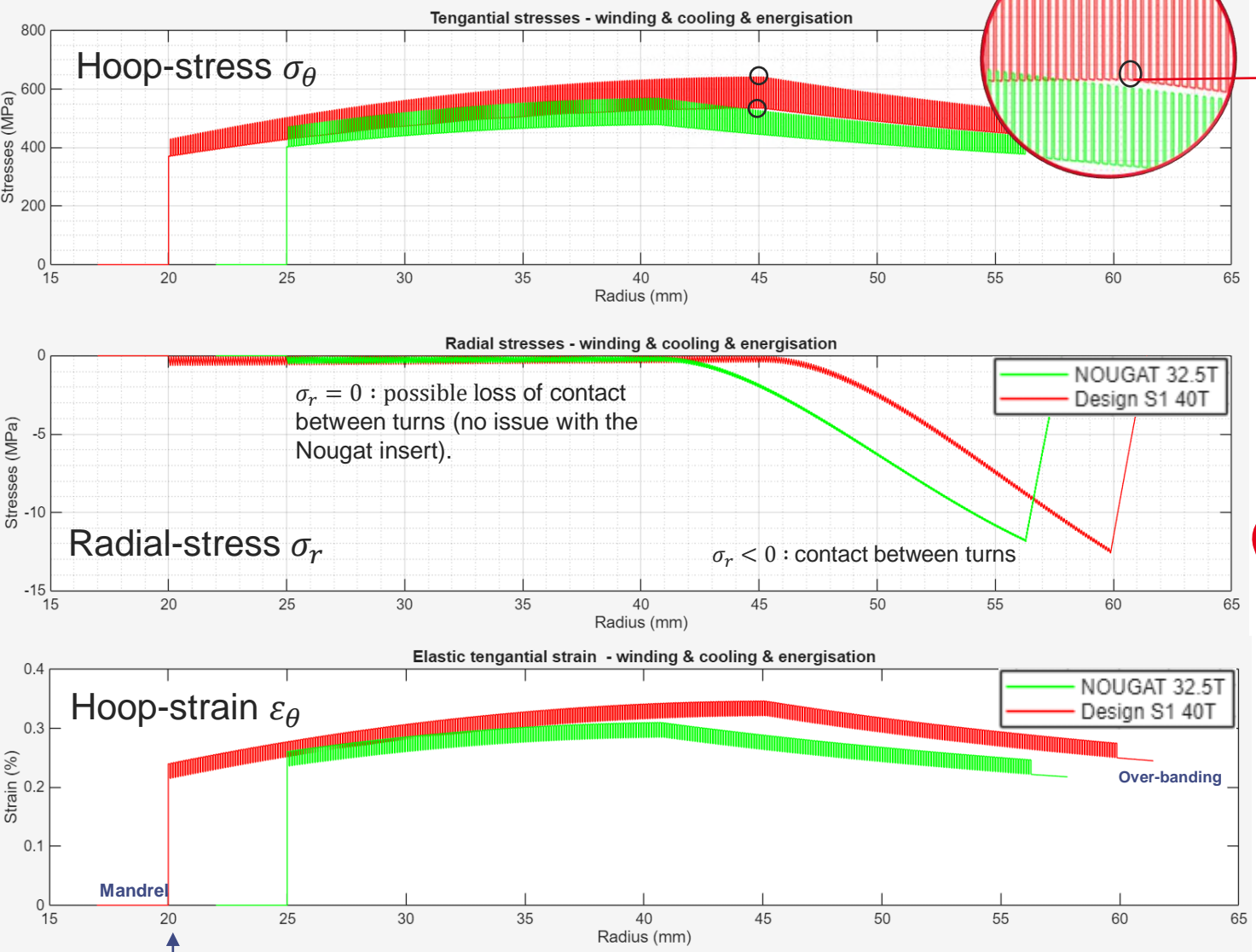

Co-winding Durnomag
max Hoop-stress : 655 MPa

ReBCO tape
max Hoop-stress : 534 MPa

Mid-plane pancake analysis

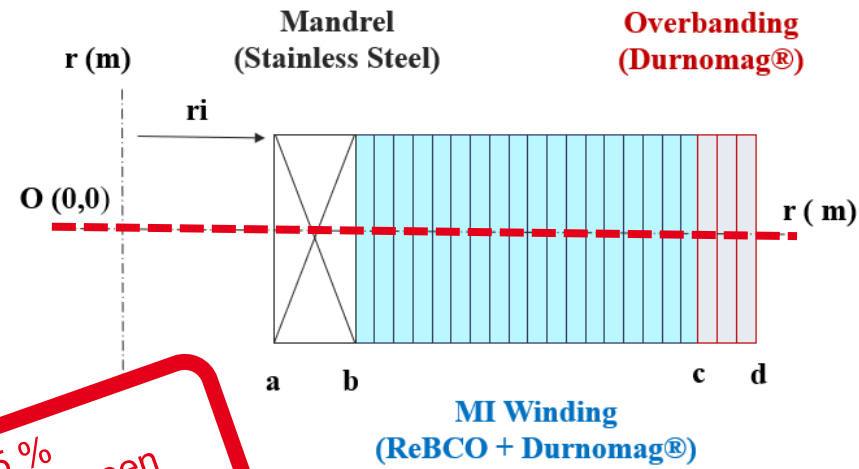

A gap of 15 % (100 Mpa) between 32.5T and 40T designs.

		Nougat 32.5 T	Deign S1 40T
Nb turns [-]	[-]	290	360
Nominal current	[A]	318	293
External field	[T]	18	19
Over-banding turns	[-]	50	50
Max hoop-stress	[MPa]	569	655
Max elastic hoop-strain	[%]	0.31	0.36
$\sigma_r = 0$	[-]	yes	yes

Internal radius



Special case : the screening current issue

Strong mechanical issues

- High current density area with reverse directions
- Strong & localised opposite induced Lorentz forces
- High tensile & compressive hoop stresses and shear stress effect
- Mechanical and magnetic degradation : Ic decrease & local plastic behavior

The particular case of the Little Big Coil 45T+ NHMFL

- SC induced hoop-stress > 1 GPa

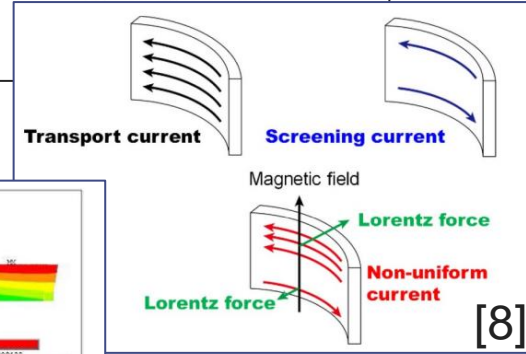
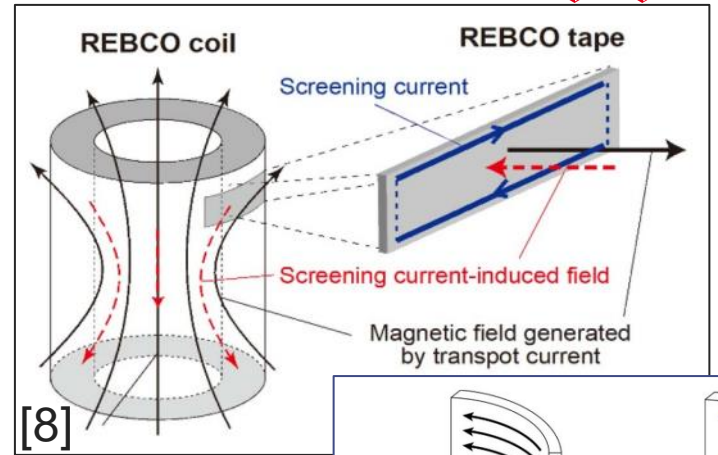

Hoop stress with SC calculation inducing plastification of HTS tapes

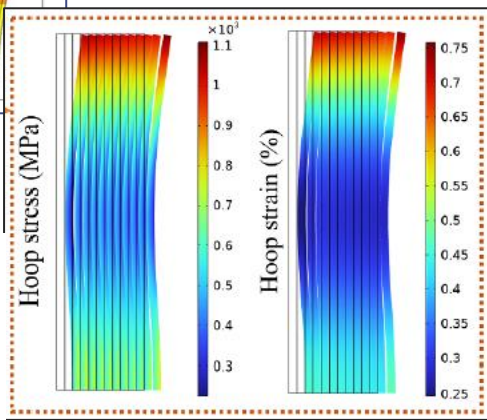
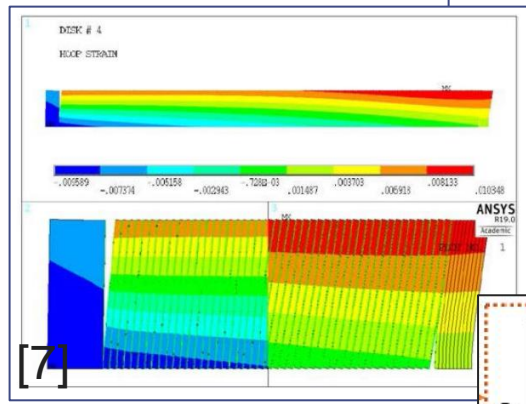
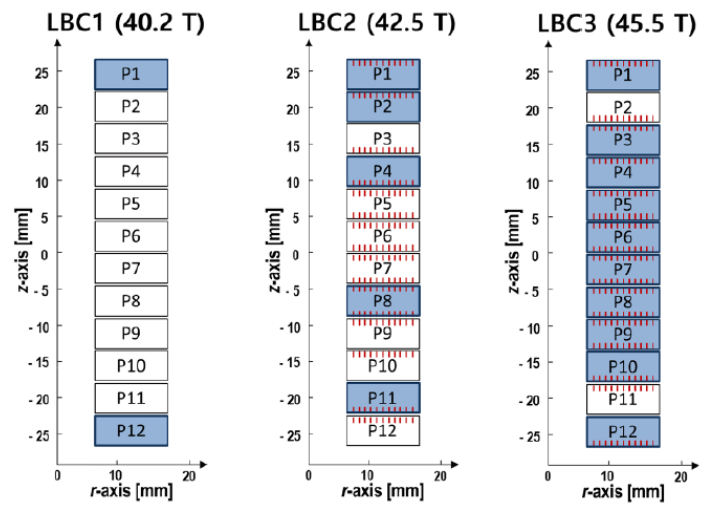
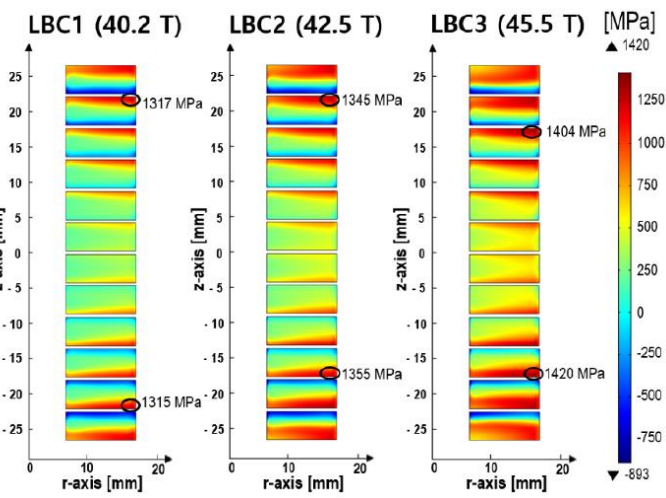

Unwound tape with plastified edge.



FASUM 40 T : calculation of screening current

■ A-V formulation code (In house 2D axisymmetric model) to achieve the SC distribution

□ Results of SC distribution within the Design_S1 40T

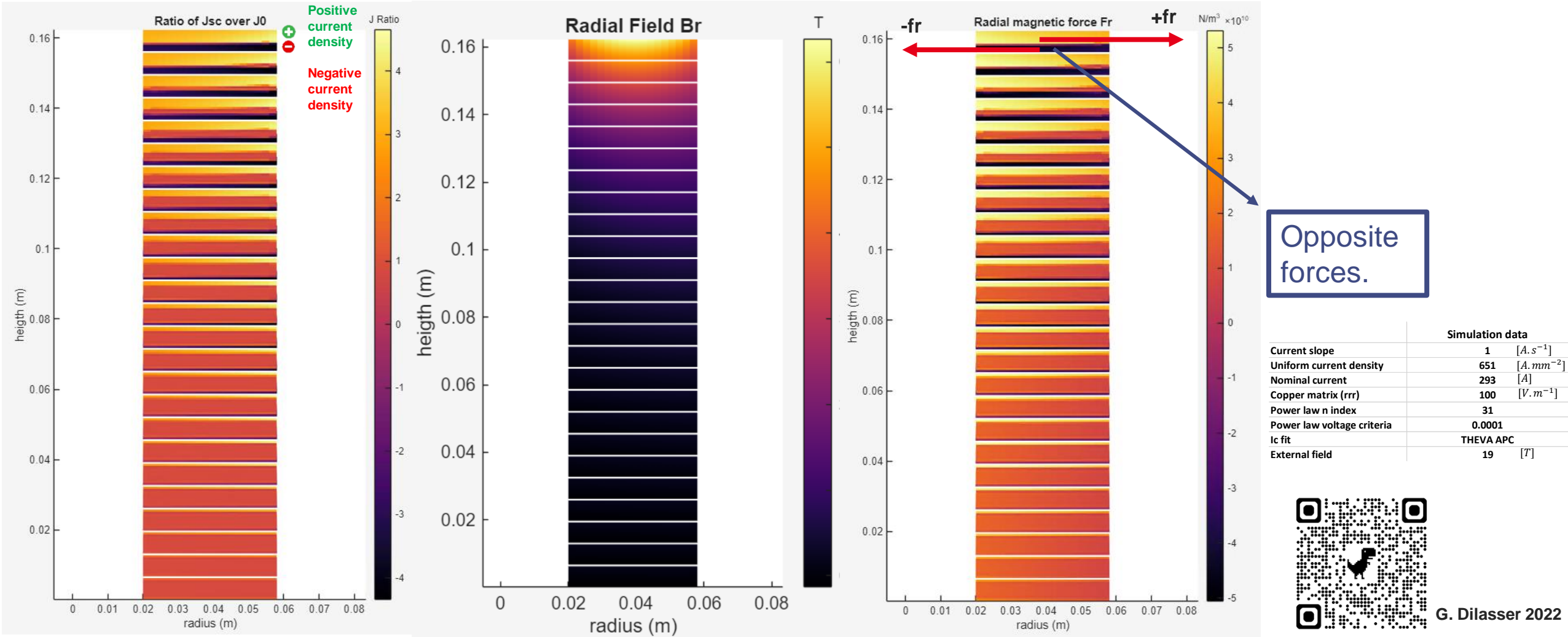

G. Dilasser 2022

FASUM 40 T : calculation of screening current stresses & strains



Comparative mechanical study with **homogenised** co-wound tapes :

Hoop-stress Nougat 32.5T
Uniform current density

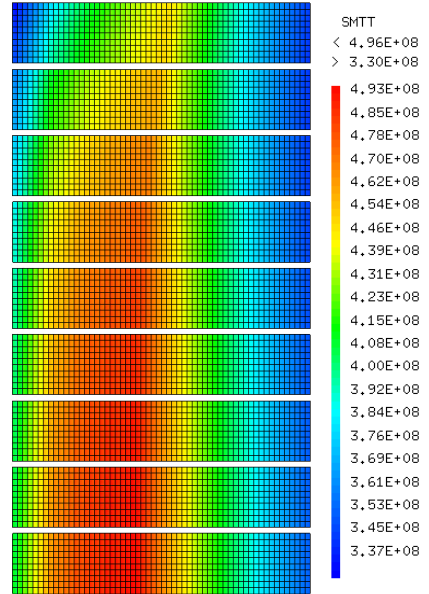

Hoop-stress Nougat 32.5T
Screening current density

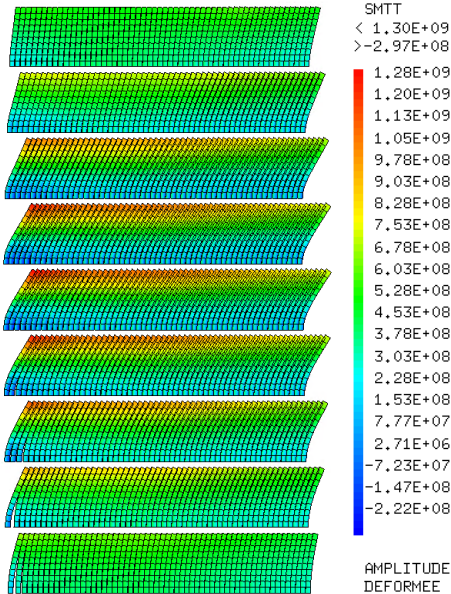

Hoop-stress Design_S1 40T
Uniform current density

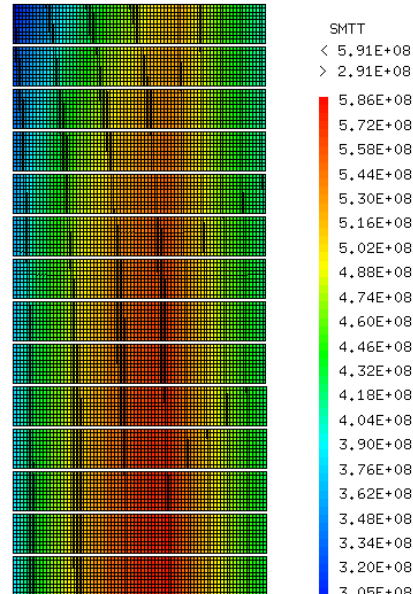

Hoop-stress Design_S1 40T
Screening current density

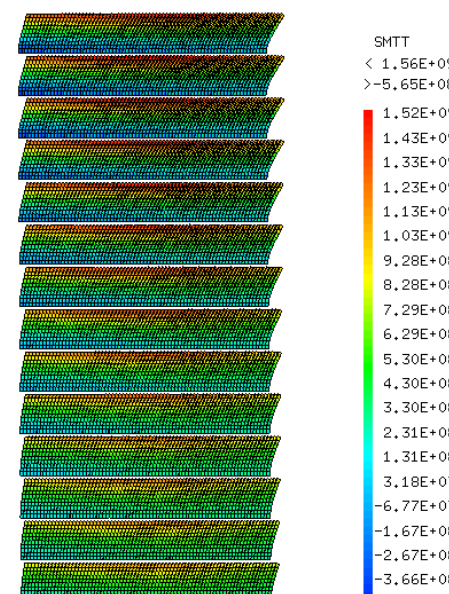

Focus on elastic hoop-strain for the 4 top pancakes.

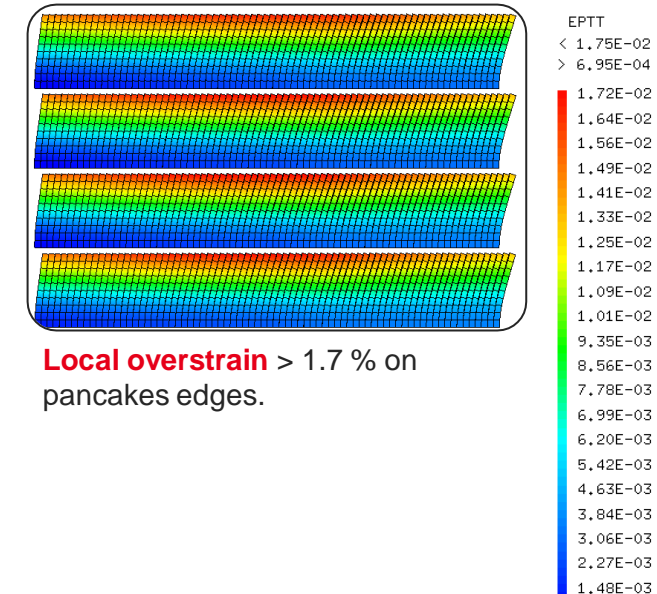

		Nougat 32.5 T	Design_S1 40T
Max hoop-stress @ J0	[MPa]	496	591
Max elastic hoop-strain @ J0	[%]	0.285	0.55
Max hoop-stress @ JSC	[MPa]	1280	1560
Max elastic hoop-strain @ JSC	[%]	1.51	1.44

1 GPa results exceeding mechanical allowable stress & strain for REBCO conductor.

■ Results exceeding mechanical strength

- Hoop-stress > 1GPa exceeding REBCO elastic behavior
- Hoop-stress >0.4 % starting Ic degradation
- No friction and axial pressure taken into account
- Few plastic behavior observed with the Nougat 32.5T experimentation in spite of the 1300 MPa predicted by calculation.

→ Need further studies

Keys : for mechanical issues in the HTS insert



■ Conclusions & discussion of FASUM single coil mechanical analysis

- For the FASUM 40T the **Single coil HTS insert** configuration have been chosen for its **economical reason**. Although the nested coil configuration shows interesting mechanical performances.
- Mechanical results on the FASUM 40T single coil design_S1 with uniform current density show high but **reasonable stress** and strain level, **below 0.4%**.
- **Screening current analysis** shows **very high stress and strain level** exceeding ReBCO allowable stress. These results **needs further study** especially with the taking into account of **the friction between pancakes due to axial pressure**.
- The issue of **contact loss** observed in the mechanical study may occur due to high number of turns of the FASUM design_S1 and **need to be further studied** as it is not a concern in the Nougat 32.5T experiment.

■ Solutions for the high stress level :

- **High pre-winding** tension (MI technology) + strong **over banding**
- **Pre-compression ring** : [Muon Collider] bladders or frets are difficult with the FASUM configuration : no space for reinforcement
- **MI2 impregnation** [CEA Patent] consist in MI + impregnation (wax, resin) = self-protection + mechanical reinforcement
- **NI + Soldering/Partial soldering** : [Muon Collider] & [Tokamak NRJ]

■ Solutions for the screening current effect :

- ReBCO tape **striation**
- Reduction of REBCO **tape width**
- Low ramping **time constant** or current overshoot
- Adjusting **a/b plane** direction with **field orientation**
- **Vortex-shaking**

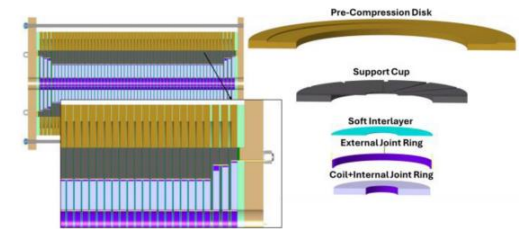
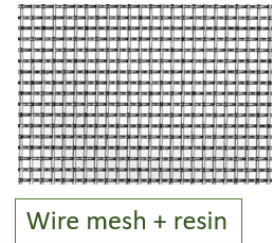
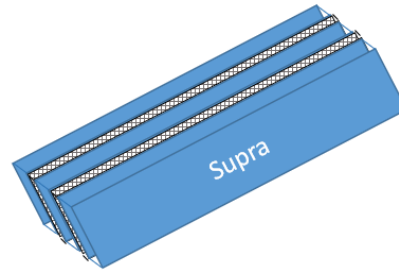

Muon Collider 40T magnet compression ring

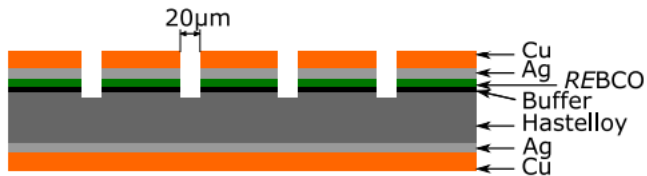

Fig. 1. Cross-sectional diagram of the superconducting striated tape with five filaments after cutting the edges.

A. Godfrin 2017



MI2 CEA Patent - 2025
Courtesy of F.Rondeaux P.Fazilleau T.Lecrevisse



C. Accetura 2025



2. Mechanical issues with HTS/LTS interactions : **FASUM 40T** project.

■ Problematic & issues

Magnetic interactions between HTS insert and LTS outsert.

Strong resultant forces induced, to manage : axial & lateral

No Torque issues with MI technology : conclusions of the superEMFL study.

Two main issues to tackle :

- **Quench** of the HTS insert / LTS outsert
- **Lateral / axial misalignment** of the HTS insert within the LTS outsert

Mechanical resultants due to magnetic interactions between HTS and LTS coils.

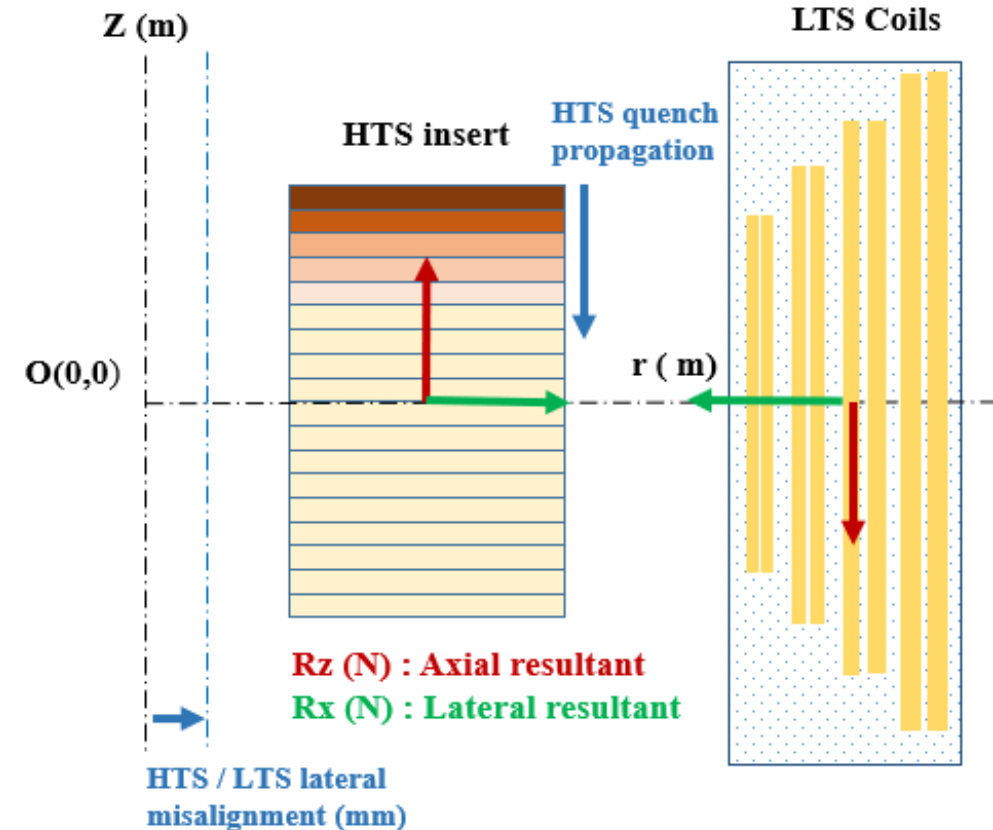

FASUM 40 T : mechanical issues of HTS/LTS interactions

■ Quench of the HTS insert

- **Asymmetrical quench of the HTS pancakes.** Ignition starting at the top intern of the solenoid.
- Impact of the **magneto-gravitational forces** due to helium diamagnetism.
- Progressive **quench of the HTS pancakes** induce an strong **axial resultant**.

■ Calculation of the axial resultant in the case of the HTS asymmetrical quench

Axial resultant due to increasing number of quenched pancakes.

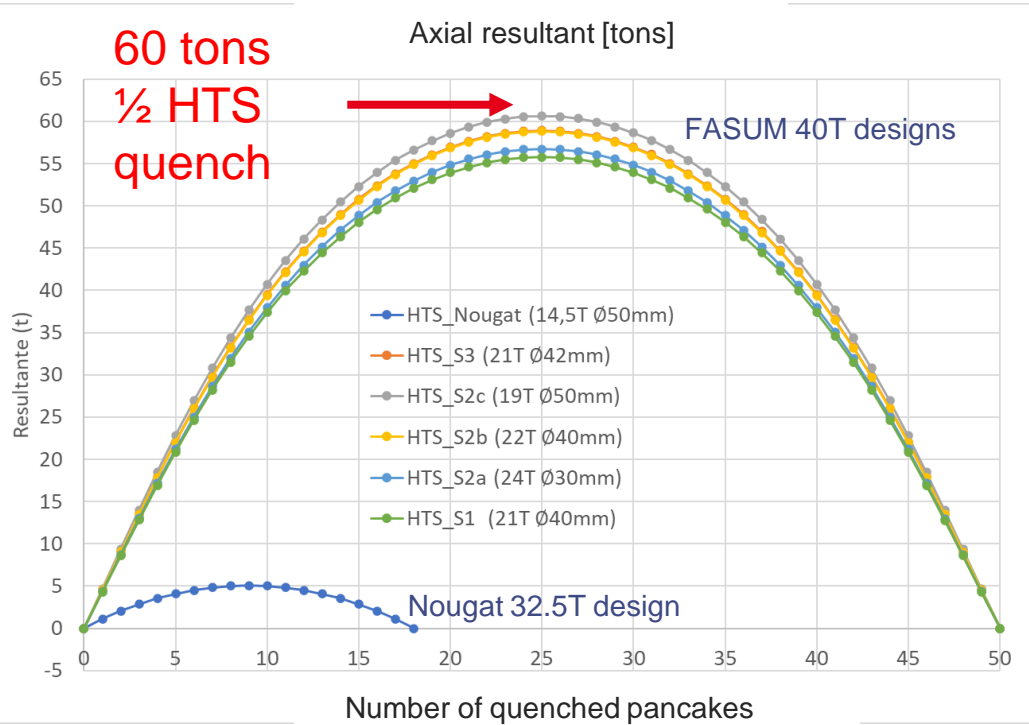

2D magnetogravitational resultants mapping on top of the Nougat HTS insert.

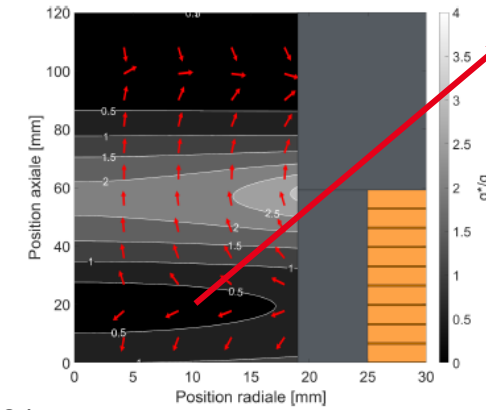

Trapped helium bubbles area. Local degradation of the cooling performances.

S. Bagnis 2023



E. Pardo 2024

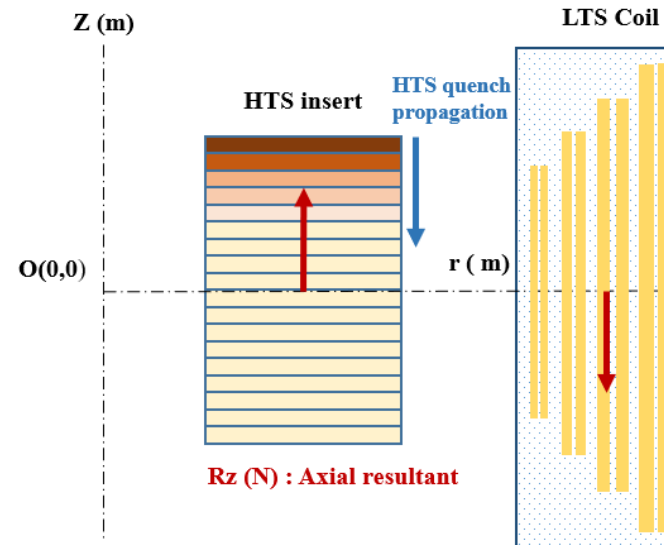

■ High axial resultant

- **Calculated theoretical value of 60 tons** in the worst case (half of the HTS quench) but **mitigated with quench numerical modelisation : taken as 25 tons.**
- Need to **reinforce axially the LTS outsert.**
- Need to **design a fixing device** between HTS insert and LTS base plate.



FASUM 40 T : mechanical issues of HTS/LTS interactions

LTS outsert quench

- Symmetrical quench of the LTS coil with respect to the median plan.
- No mechanical issue on the HTS insert, no axial resultant except in the case of a THEVA APC REBCO tape due to the tilting angle of the a-b plane.

Results of superEMFL - axial resultants due to HTS/LTS quench event

		NOUGAT IN 19 T	32 T BASIC DESIGN	S1 40 T DESIGN
QUENCH IGNITION IN HTS PART	Axial force/pancake	58 kN	120 kN	160 kN
	Total axial resultant			2
QUENCH IGNITION IN LTS PART	Axial force/pancake	80 kN	130 kN	280 kN
	Total axial resultant	0 N	20 kN ⁴	140 kN ⁴

THEVA APC conductor : axial resultant > 20 KN
 SuperPower conductor : axial resultant = 0 KN

Results of superEMFL – Axial resultant generated in the HTS (a) and the LTS (b) parts during LTS quench event.

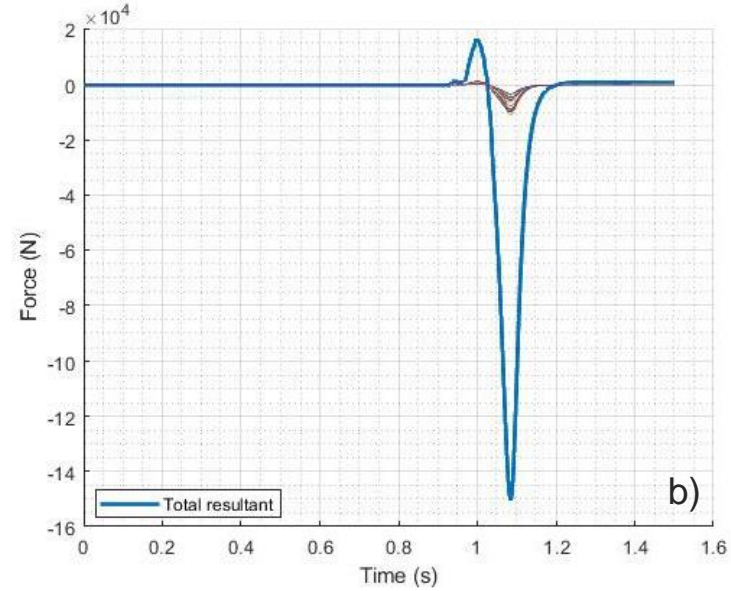
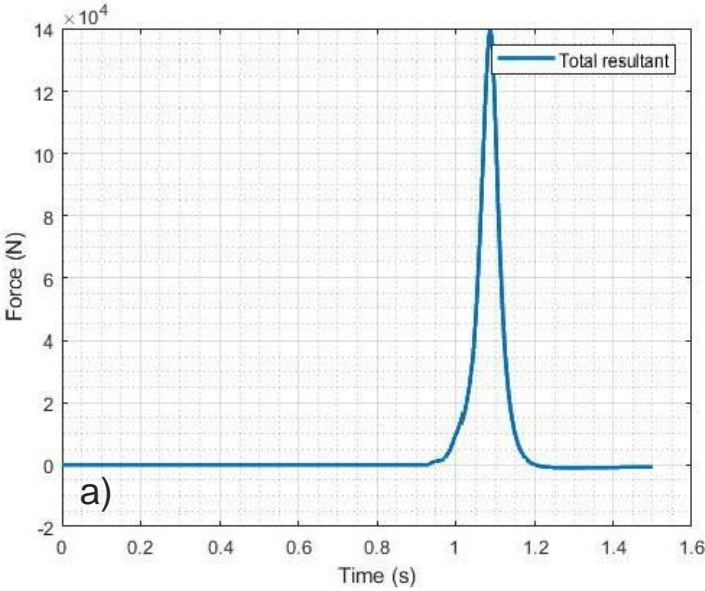

Special issue THEVA APC

- Axial resultant of 14 tons in case of the LTS quench due to THEVA APC a-b plane 30° angle.
- For future HTS insert this issue is managed with a tape orientation adjustment in order to have no axial resultant.

FASUM 40 T : mechanical issues of HTS/LTS interactions

- HTS insert axial misalignment

- HTS axial misalignment induces auto-centring forces transferred to the HTS/LTS fixing device.

- HTS insert lateral misalignment

- Lateral misalignment is a **severe issue of the FASUM project** currently. Hard to reinforce laterally the LTS coils which can resist only a limited lateral resultant value. **Quasi not allowable** with the FASUM design_S1 insert with **1 mm** lateral misalignment.

LTS max allowable lateral resultant for < 1 mm lateral misalignment.

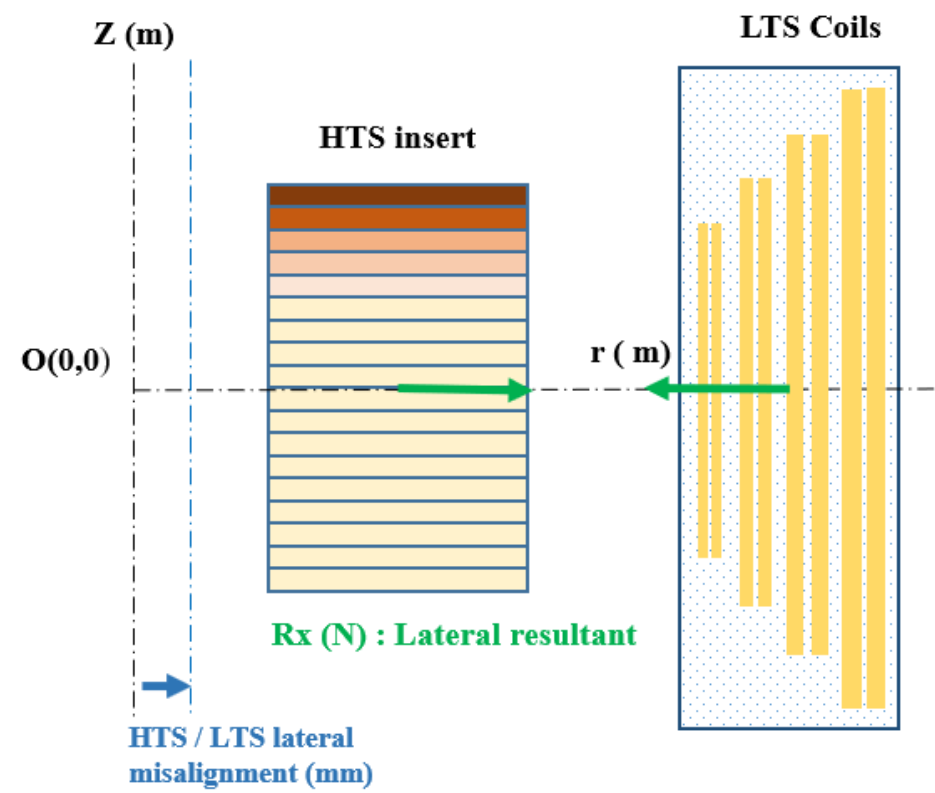
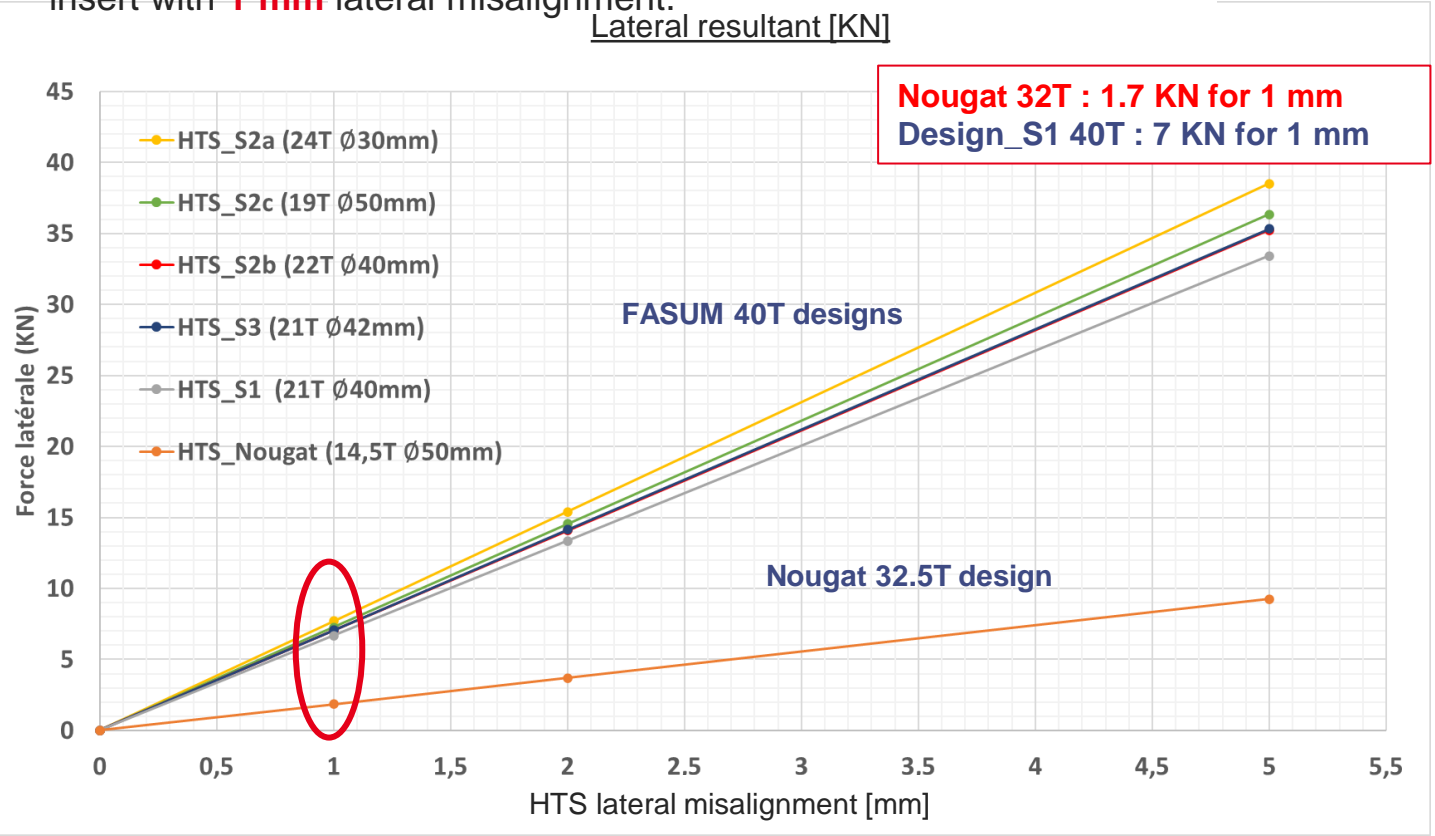

Keys for mechanical issues with the HTS/ LTS interactions

■ Conclusions of HTS/LTS mechanical interaction study

- Issue of the **HTS insert quench** inducing **25 tons axial resultant**.
- Issue of the **HTS lateral misalignment** inducing **7 KN lateral resultant** barely acceptable for the LTS coils.

■ Technical solutions to HTS/LTS mechanical interactions

- LTS outsert **axial & lateral reinforcement** : coil support and bore tube
- HTS/LTS **fixing device** to resist the axial resultant of 25 tons.
- HTS geometrical positioning : imposing a **maximum of +/-1mm lateral misalignment** during testing experiment.
- Progressive experimental **testing with increasing number of DP** :

“Current testing of the Nougat 14.5T insert in Dresden HZDR with a 18T LTS outsert delivered by Oxford Instrument : reaching 28,2T last week.”

X. Chaud & J. Song – LNCMI

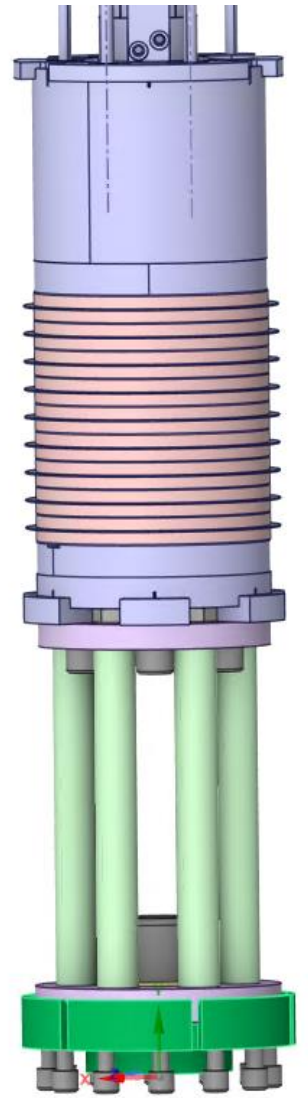

Conceptual design of the **HTS/LTS fixing device** to prevent from lateral/axial resultant.

Conclusion

■ Issues with mechanics in UHF : particular case of hybrid LTS/HTS magnet

- High increase of stress & strain level : **allowable results with uniform current density** :
Hoop stress < 800 MPa & Elastic Hoop-strain < 0.4%
- Screening current local over stress & strain : **exceeding material mechanical properties** :
Hoop stress < 1 GPa & Elastic Hoop-strain > 1%
- HTS/LTS mechanical interactions : **axial/lateral resultants** not allowable for the LTS magnet.

■ Technological implications & perspectives

- Needs for a **HTS insert design** managing the high stress and strain level with technical solutions :
MI2, pre-winding, over-banding, tape striation ..
- Needs for **LTS reinforcement specifications** : axial / lateral
- Needs for **HTS/LTS fixing device**
- Needs for further **mechanical numerical studies and modelling**:
 - Loss of contact between turns
 - Introducing the friction and axial pressure
 - Elastic-plastic behavior due to screening current over-stress
- Needs for **specific testing procedures** to mitigate the mechanical issues & validate reinforcement solutions :
progressive DP testing, over-shooting, vortex shaking, misalignment.

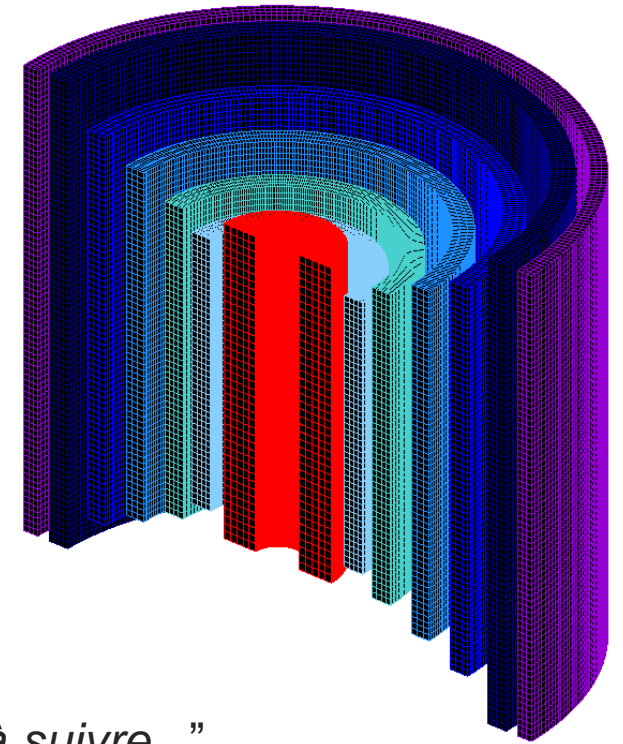

“Affaire à suivre ..”