



Coatings voor toepassingen binnen het CERN

Wil Vollenberg
TE-VSC-SCC-thin films lab

Thanks to colleagues Pedro C.P. and Matthias van Gompel for several slides



- Introductie
- Wat zijn coatings
- Hoe maken we coatings
- Belangrijke toepassing:
 - NEG
 - amorphous Carbon



Cern is een onderzoekscentrum voor
deeltjes fysica

Materiaalkunde onderzoek en ontwikkeling
ter ondersteuning van versnellers en
detectoren



Materiaalkundige ondersteuning:

- Keuze van materialen
- bewerken van materialen (warmte / chemisch / mechanisch)
- Coaten van materialen



Van Dale: Coaten is het aanbrengen van een deklaag.

Meeste gevallen is dat een dunne laag.

Voor onze toepassingen: 10 nm – 5 μ m

M.b.v. coaten veranderen we de oppervlakte eigenschappen van een materiaal.





80 nm Al
+
30 nm MgF₂

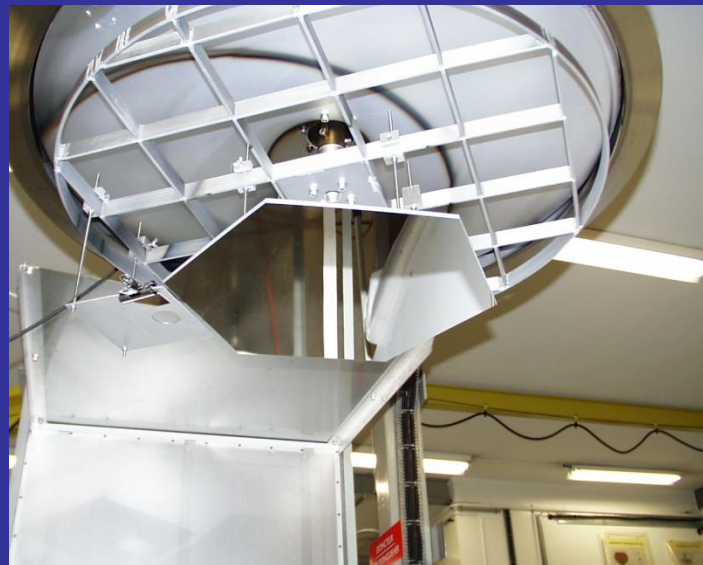

Reflectiviteit:
90 – 95 %



COMPASS **RICH**

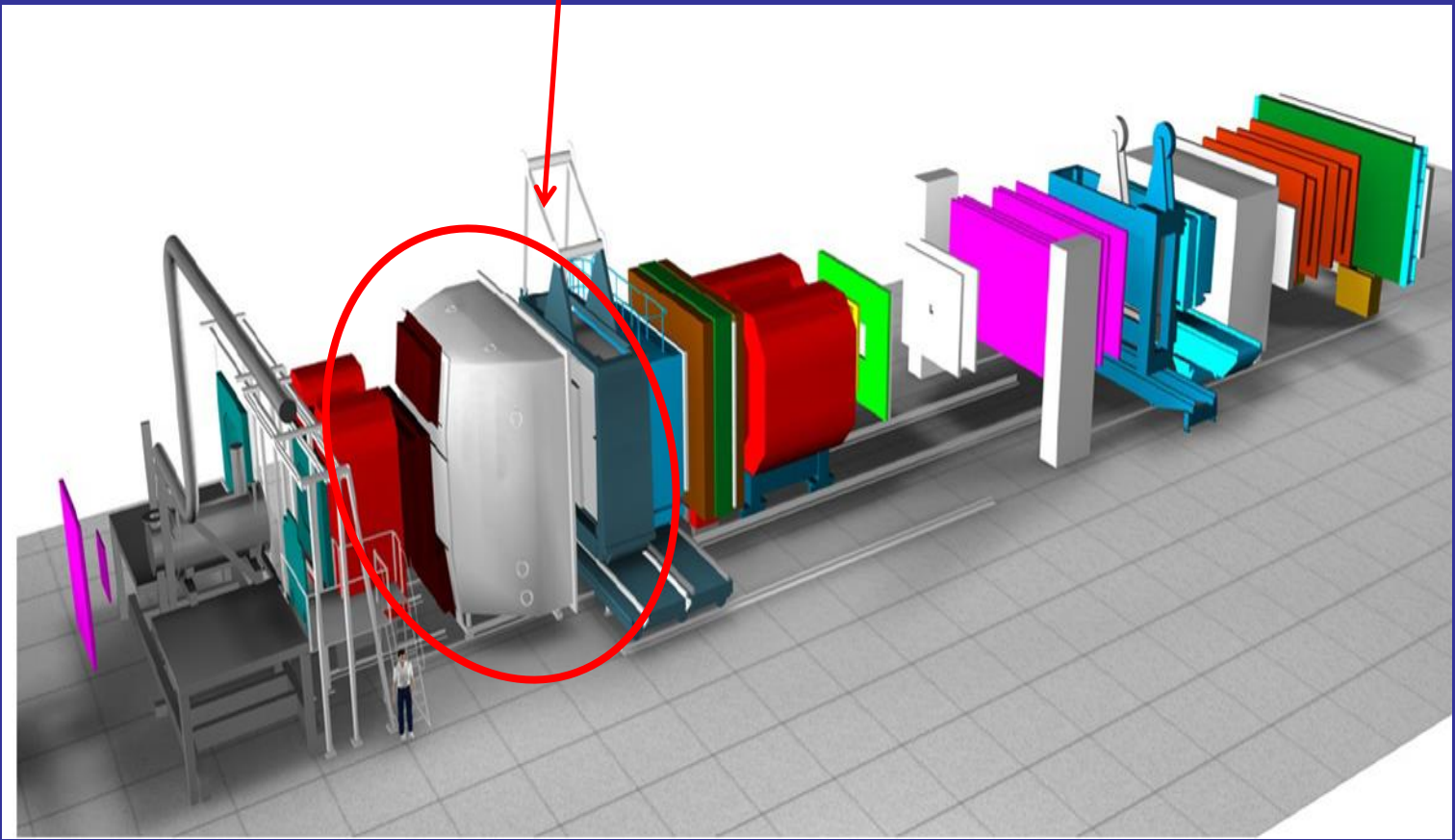

beam

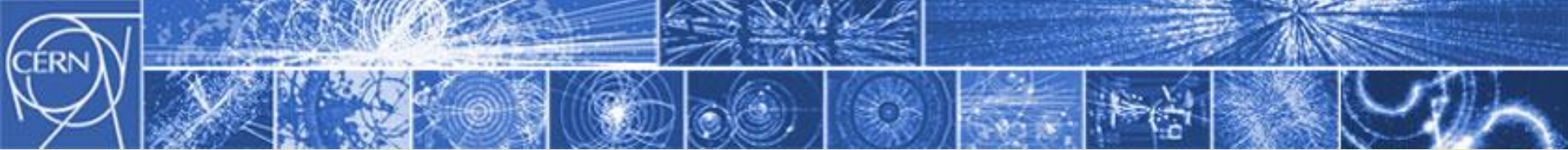

COMPASS RICH

Side View

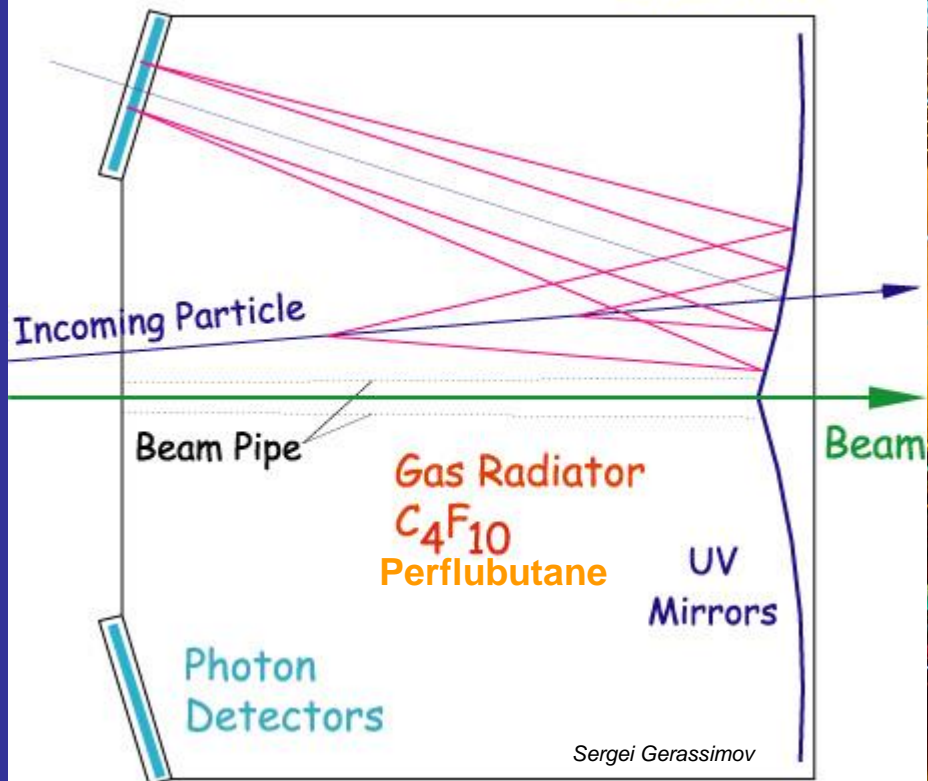

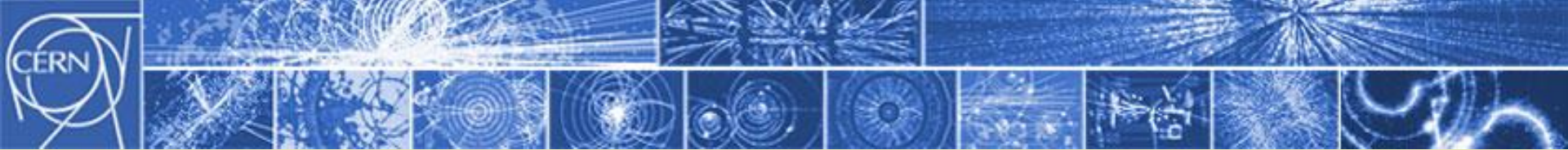

Medical Lighting

www.oerlikon.com/optics

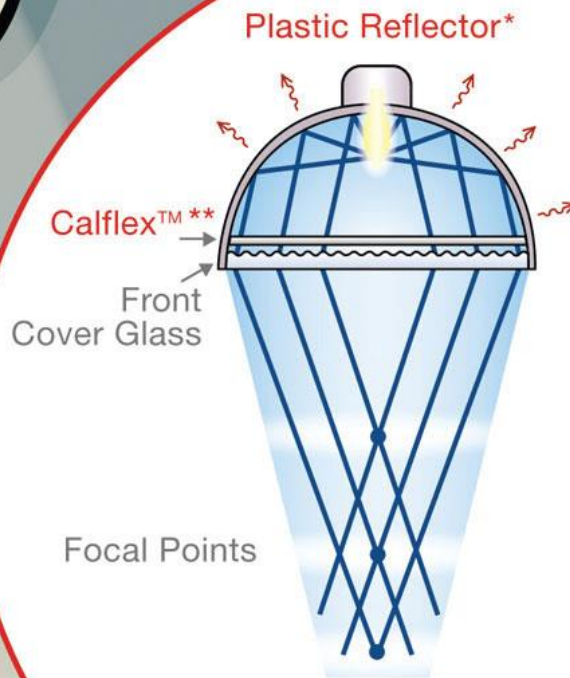

* Cold Light (Conversion) Reflector

** Combinations of Calflex™ and/or Conversion Filters

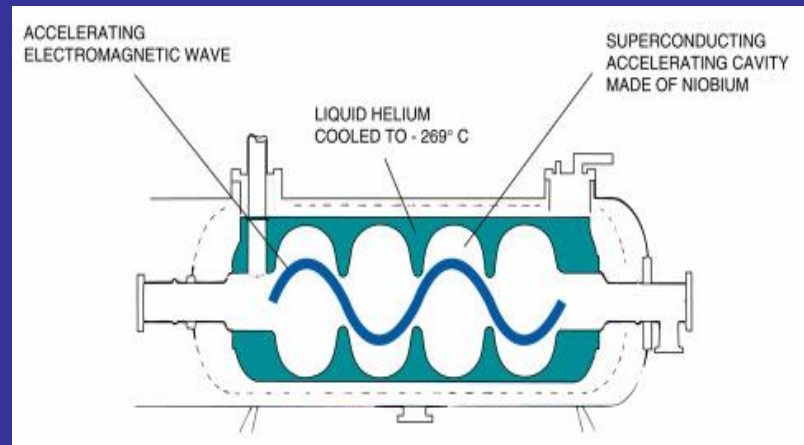
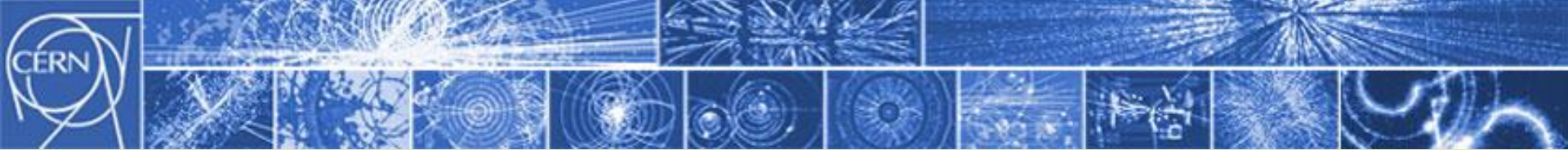

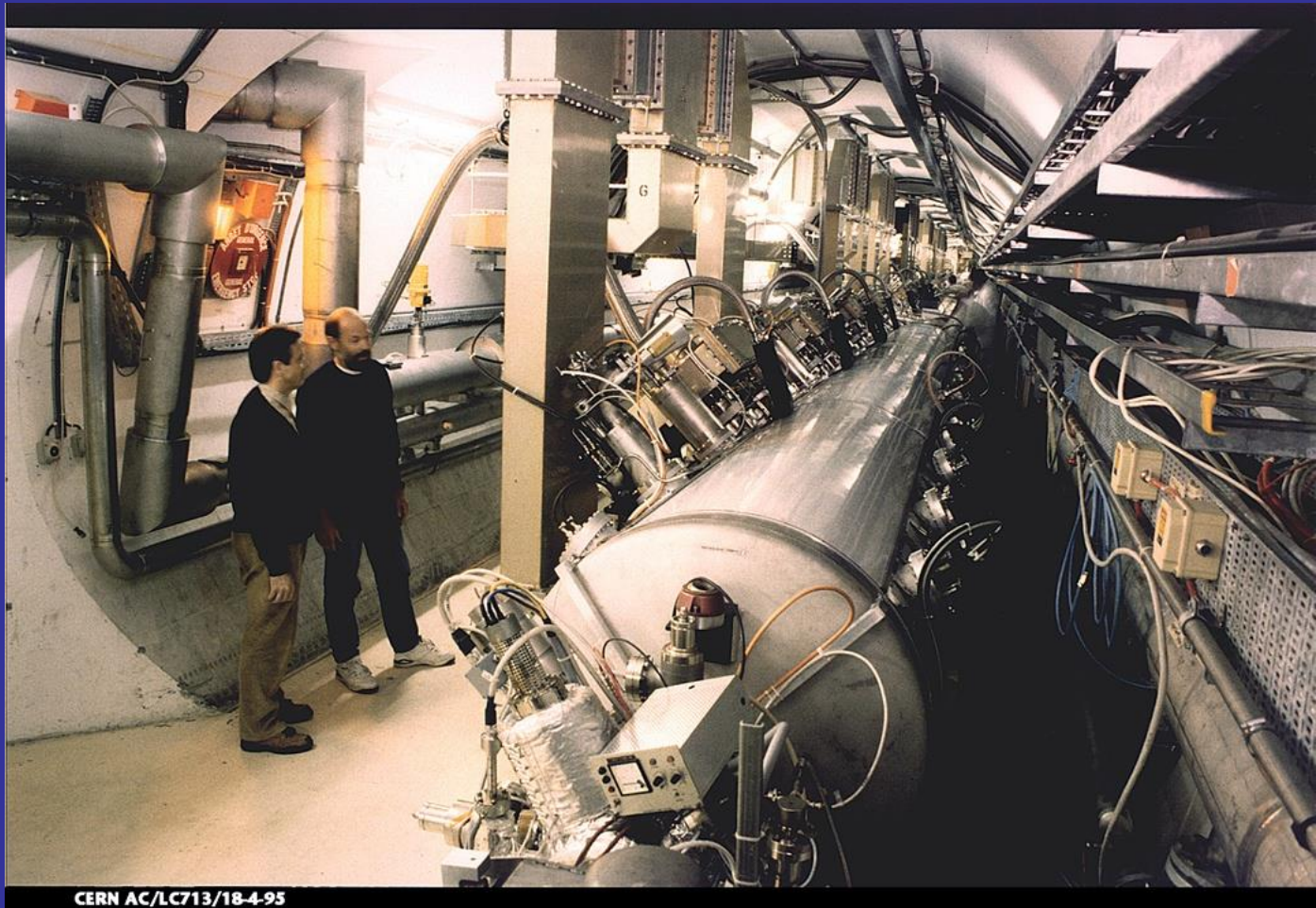

CERN AC/LC713/18-4-95



Hoe maken we coatings

- Galvanisch,
 - CVD ,
- Silicium

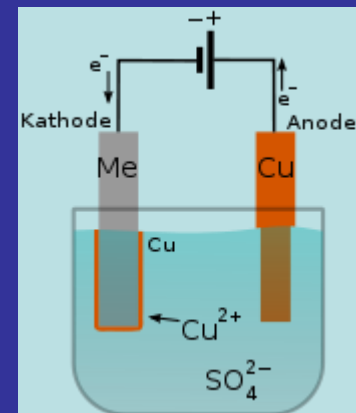

Redox-reactie

Toelichting:

- opdampen
- Plasma coaten

VACUUM



Thermisch opdampen

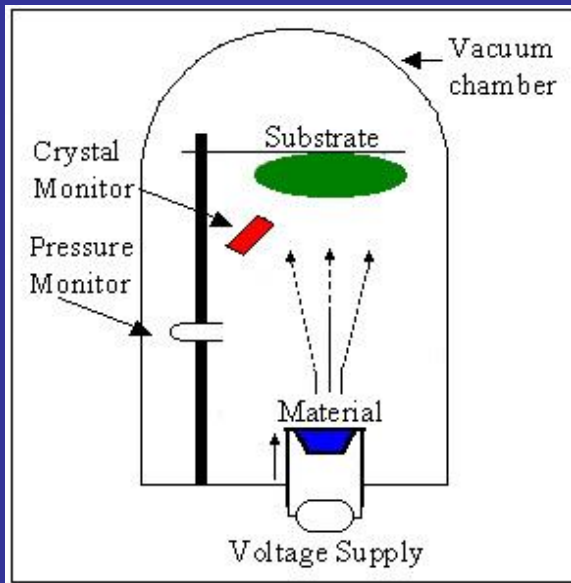

Opdampen: vaste stof \rightarrow vloeibaar \rightarrow damp
condensatie geeft coating

Waarom onder vacuum?



Plasma coating (sputter process)

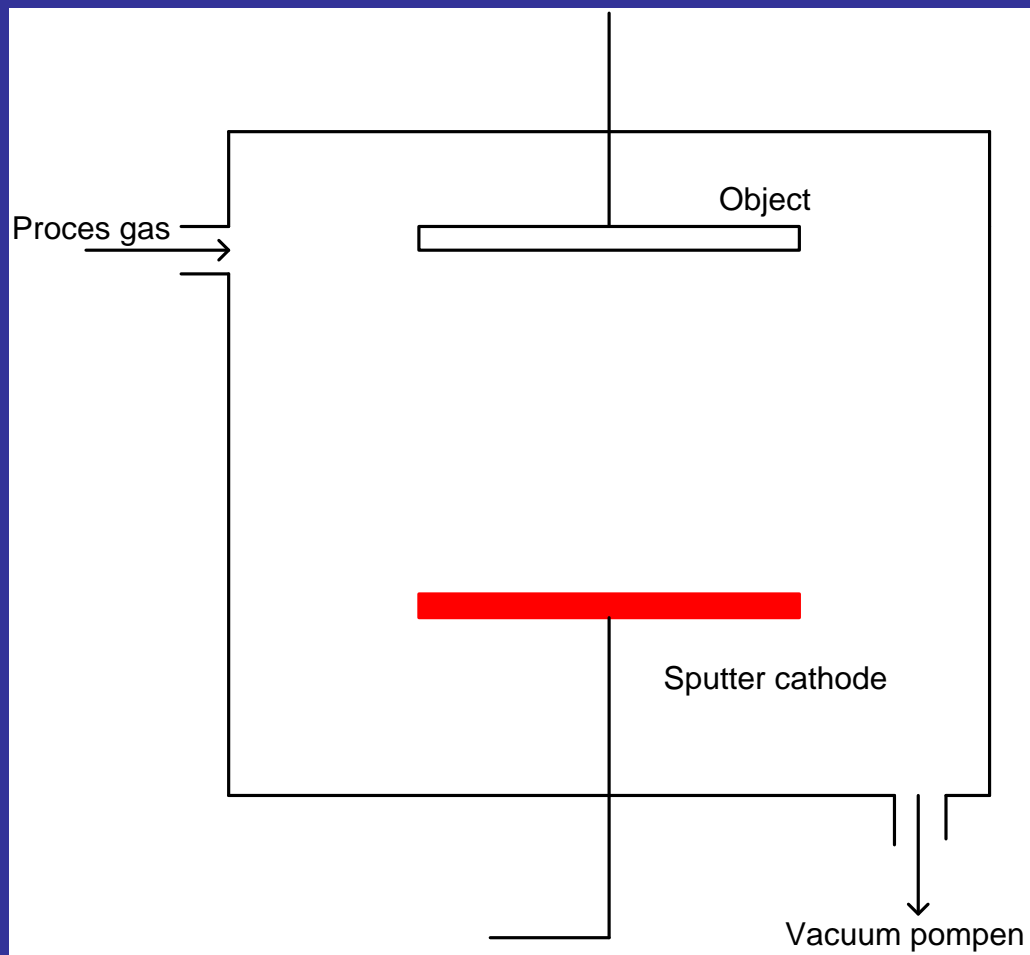



Plasma coating (sputter process)

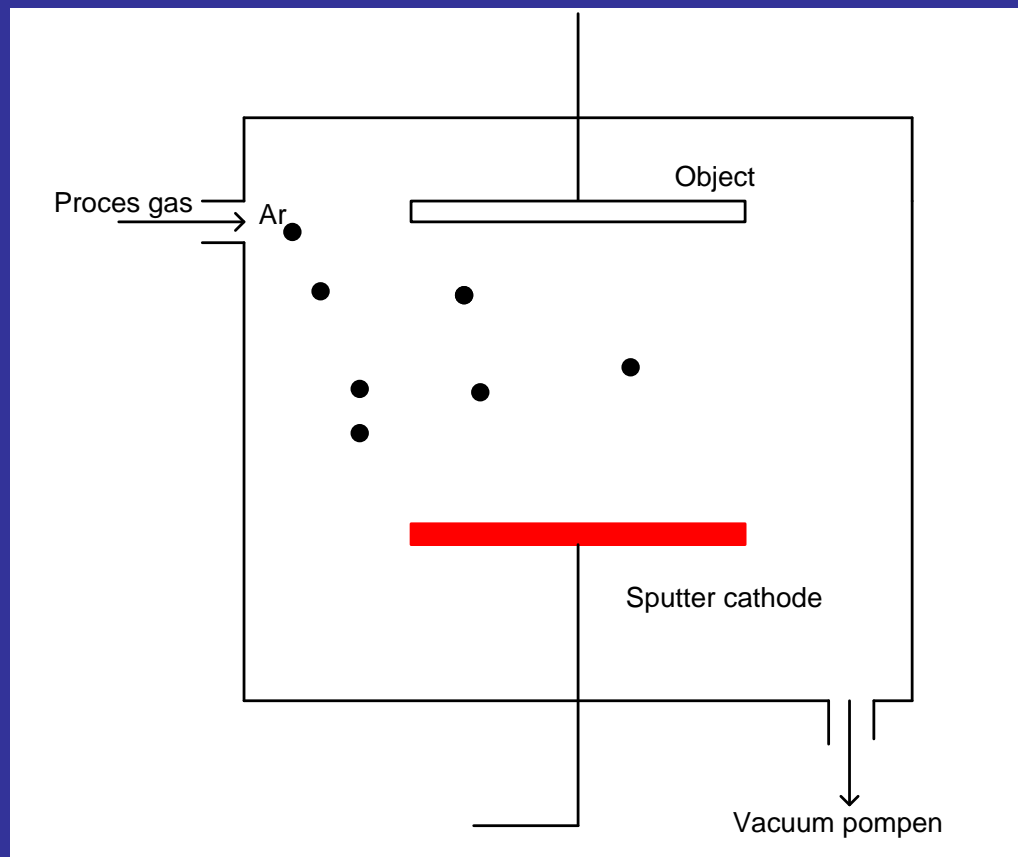



Plasma coating (sputter process)

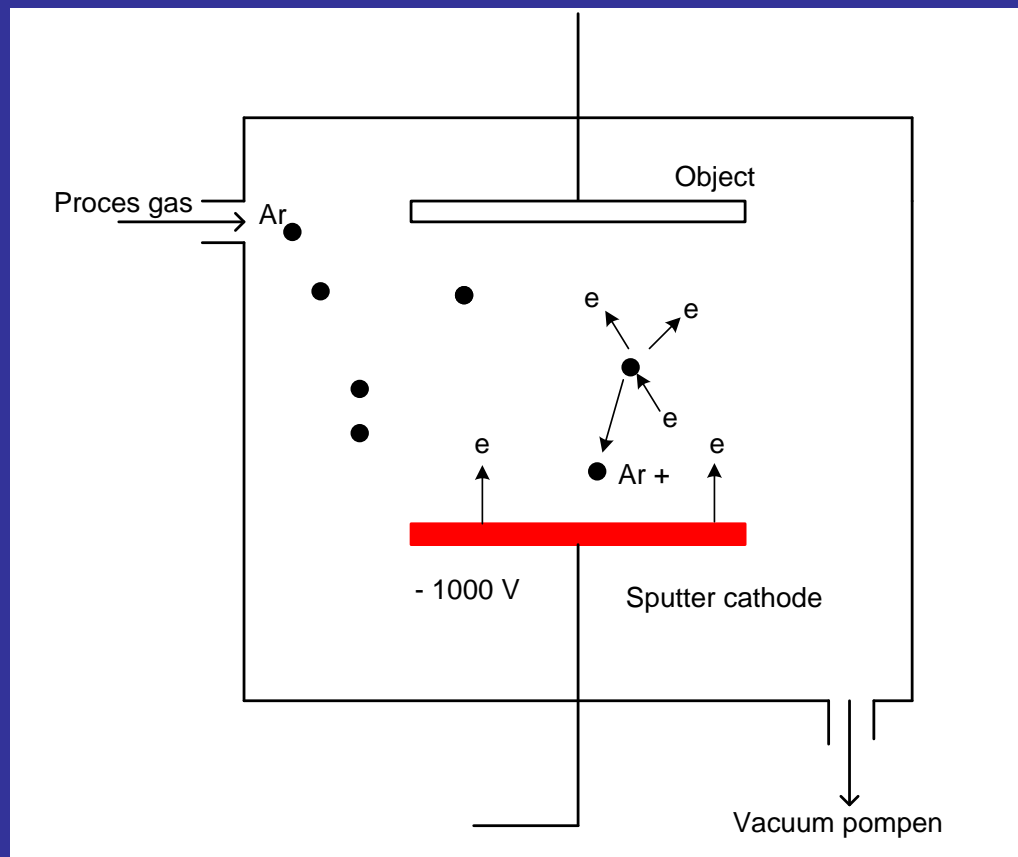



Plasma coating (sputter process)

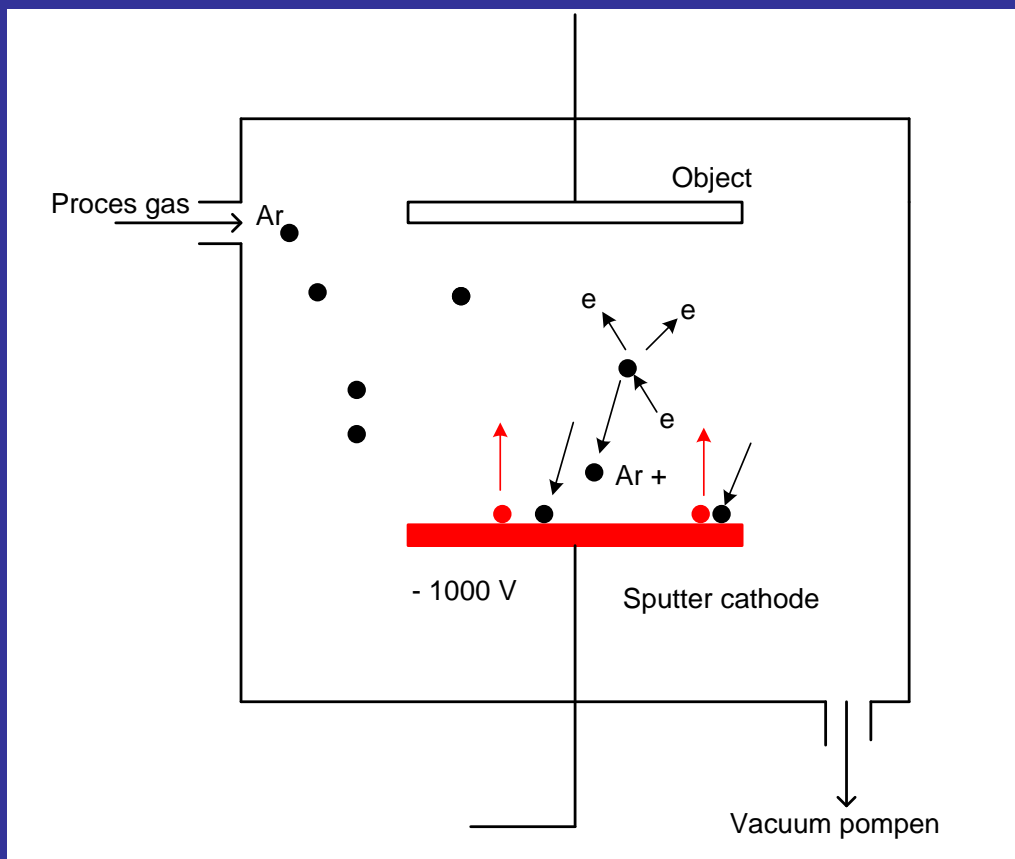



Plasma coating (sputter process)

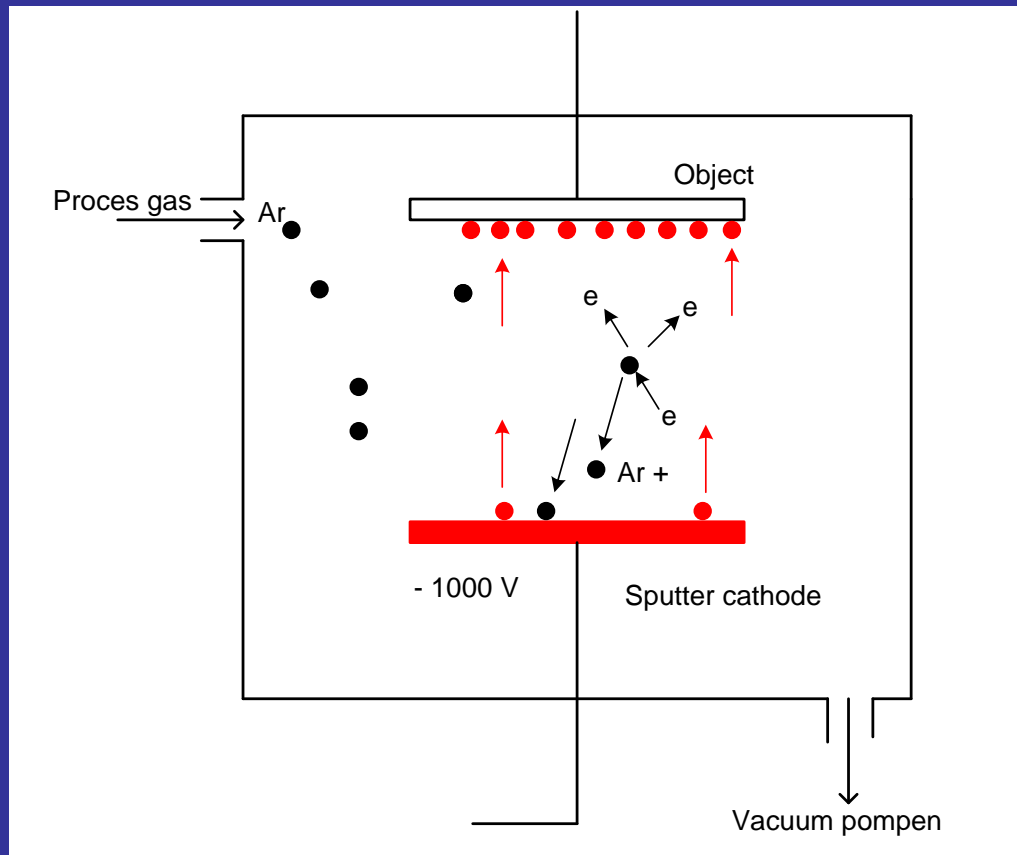



Plasma coaten (sputter process) *met magneet versterking*

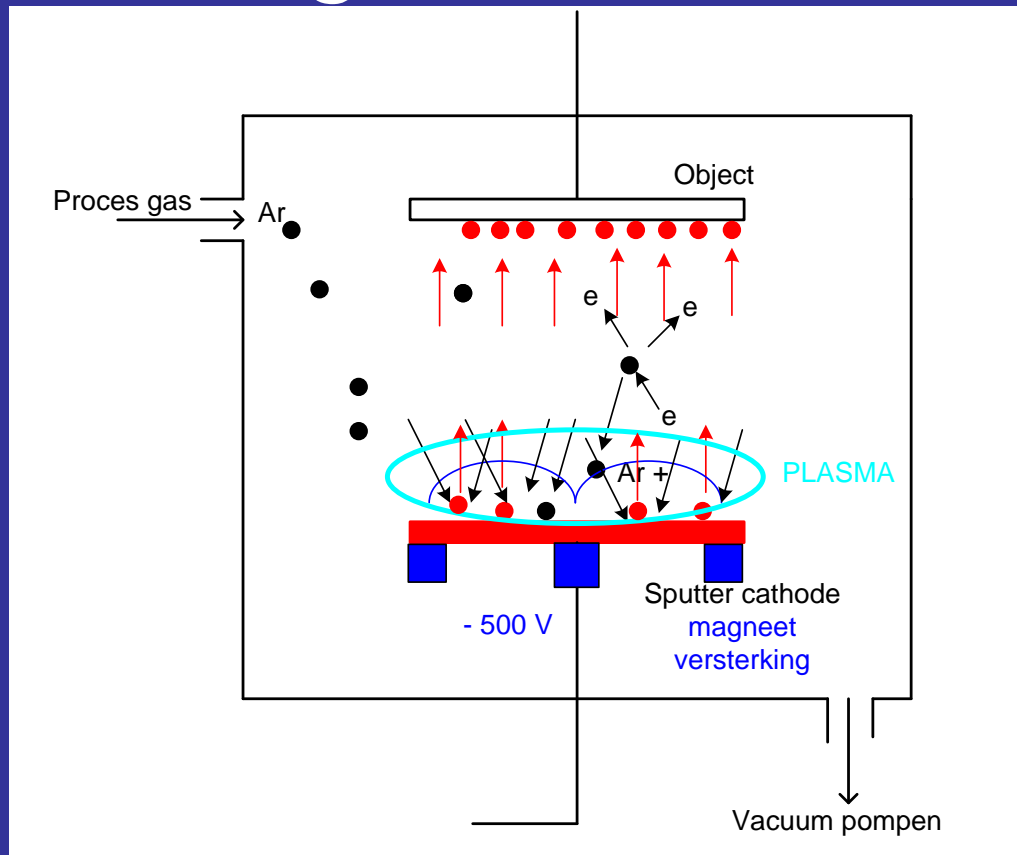

Fundamentals of Sputtering principle

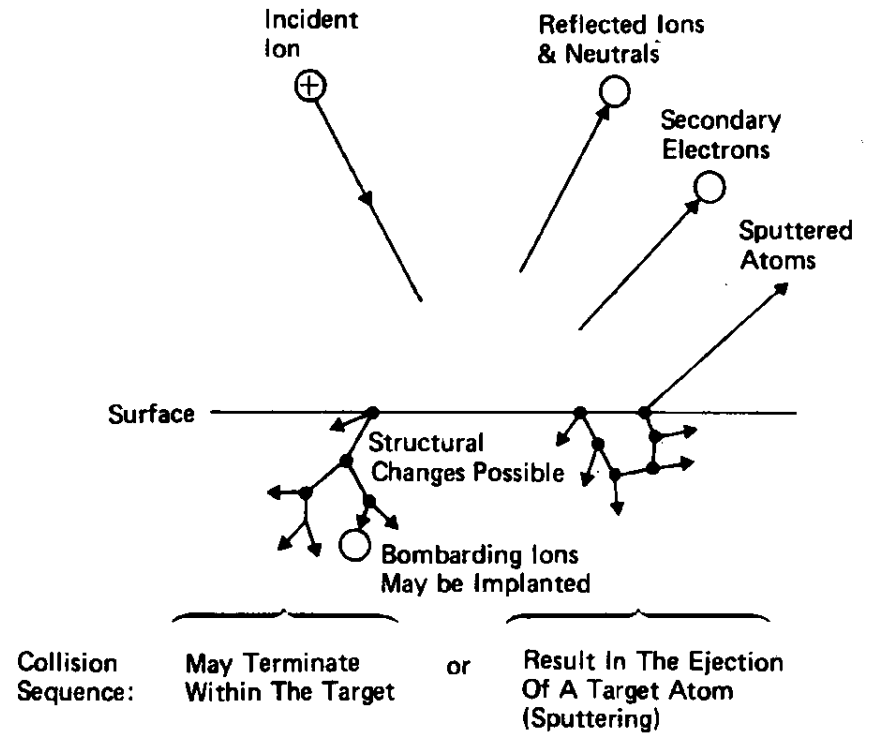
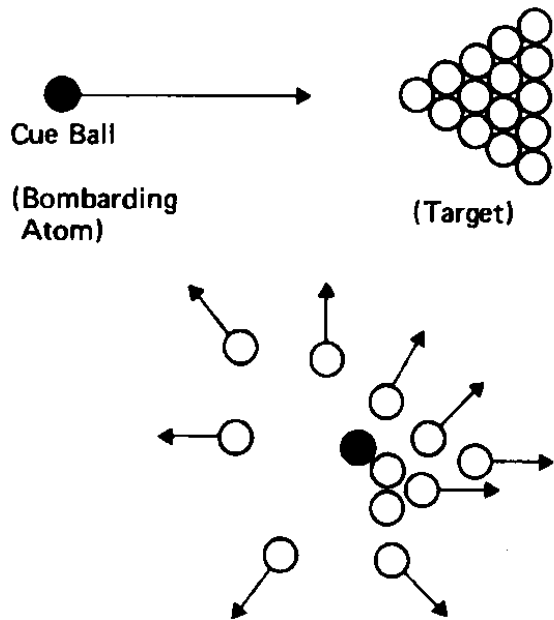
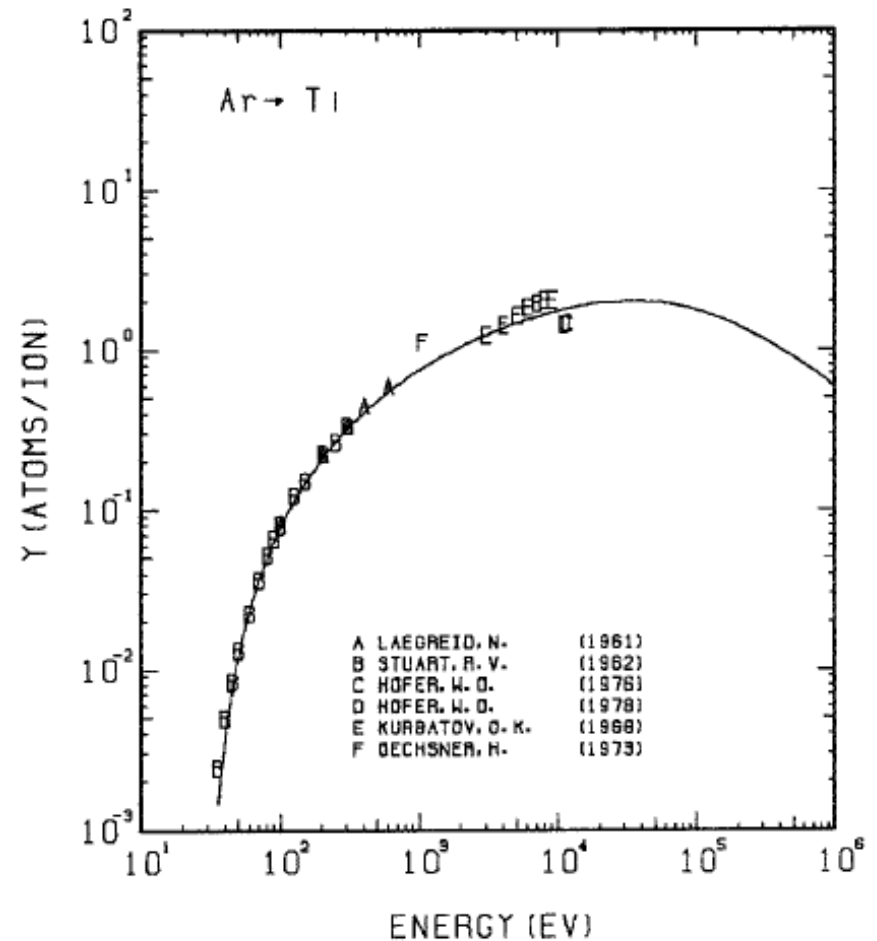
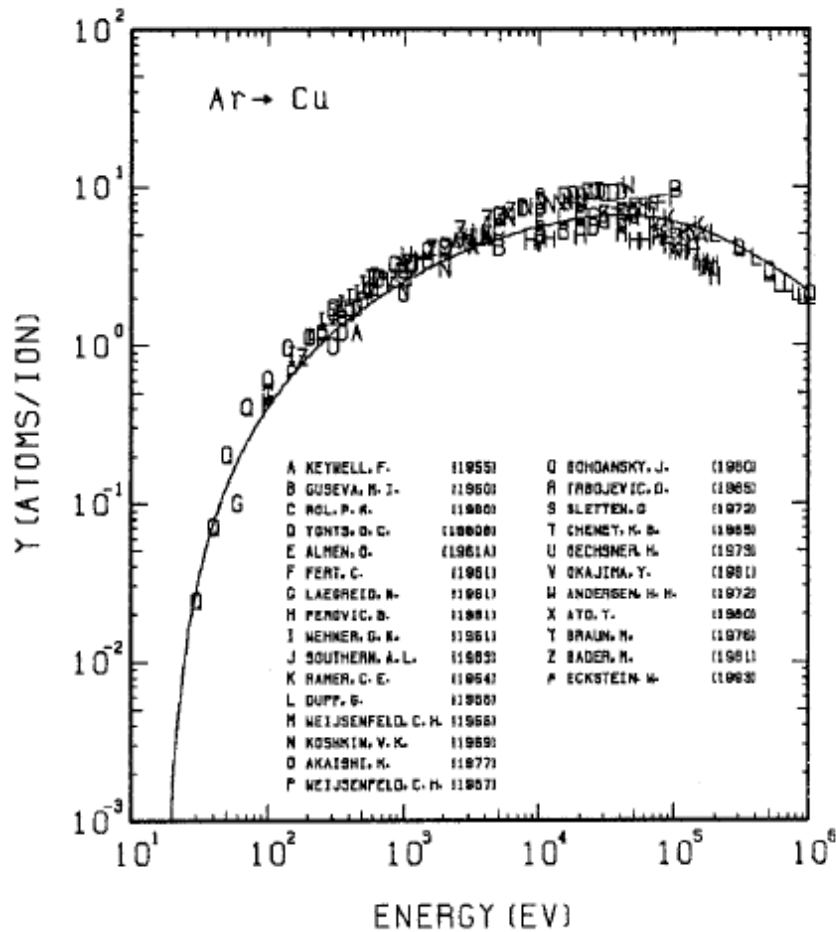

Figure 6-1. Interactions of ions with surfaces

Figure 6-2. Sputtering – the atomic billiards game

Sputtering yields





Plasma coaten (sputter process) *met magneet versterking*

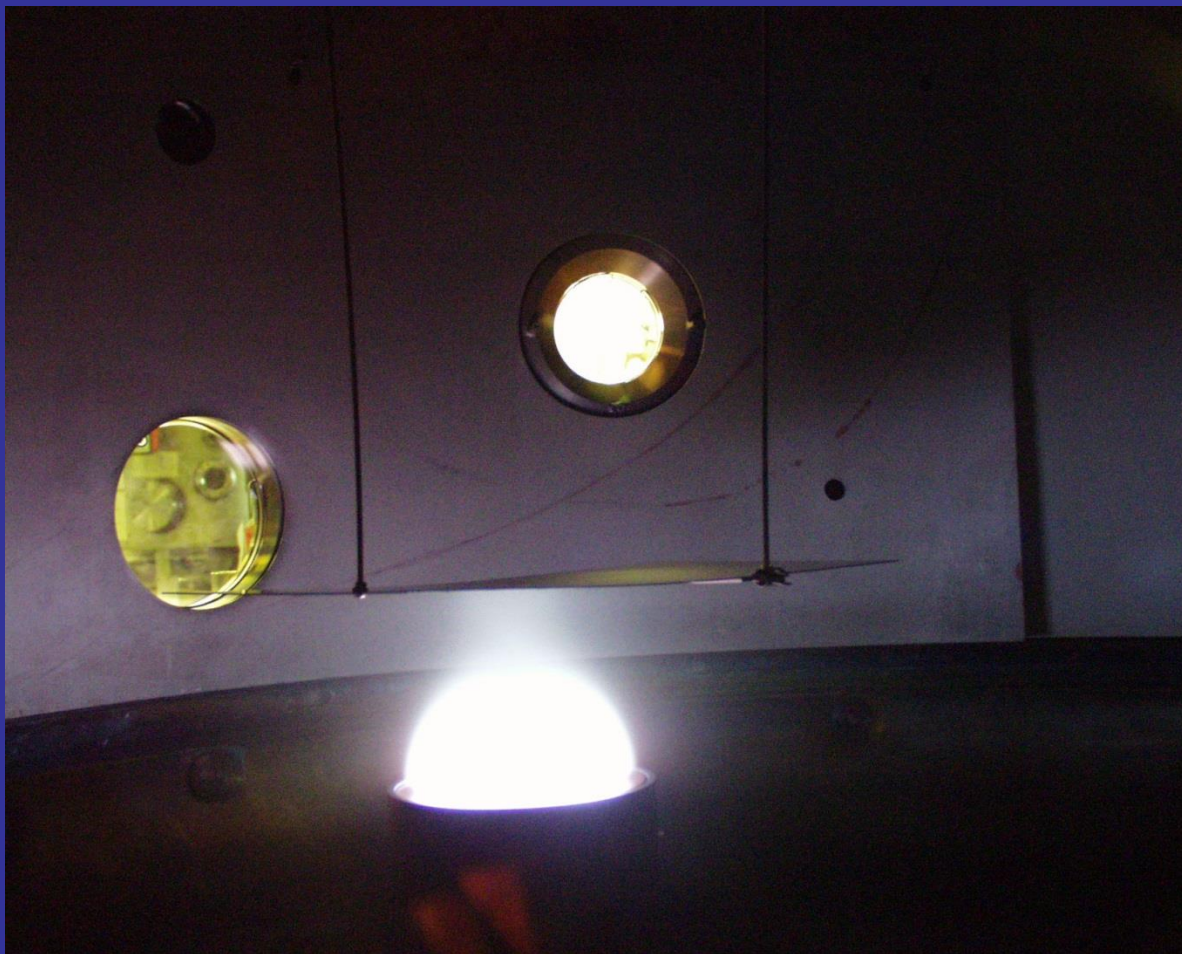



Aangeslagen toestand → foton emissie

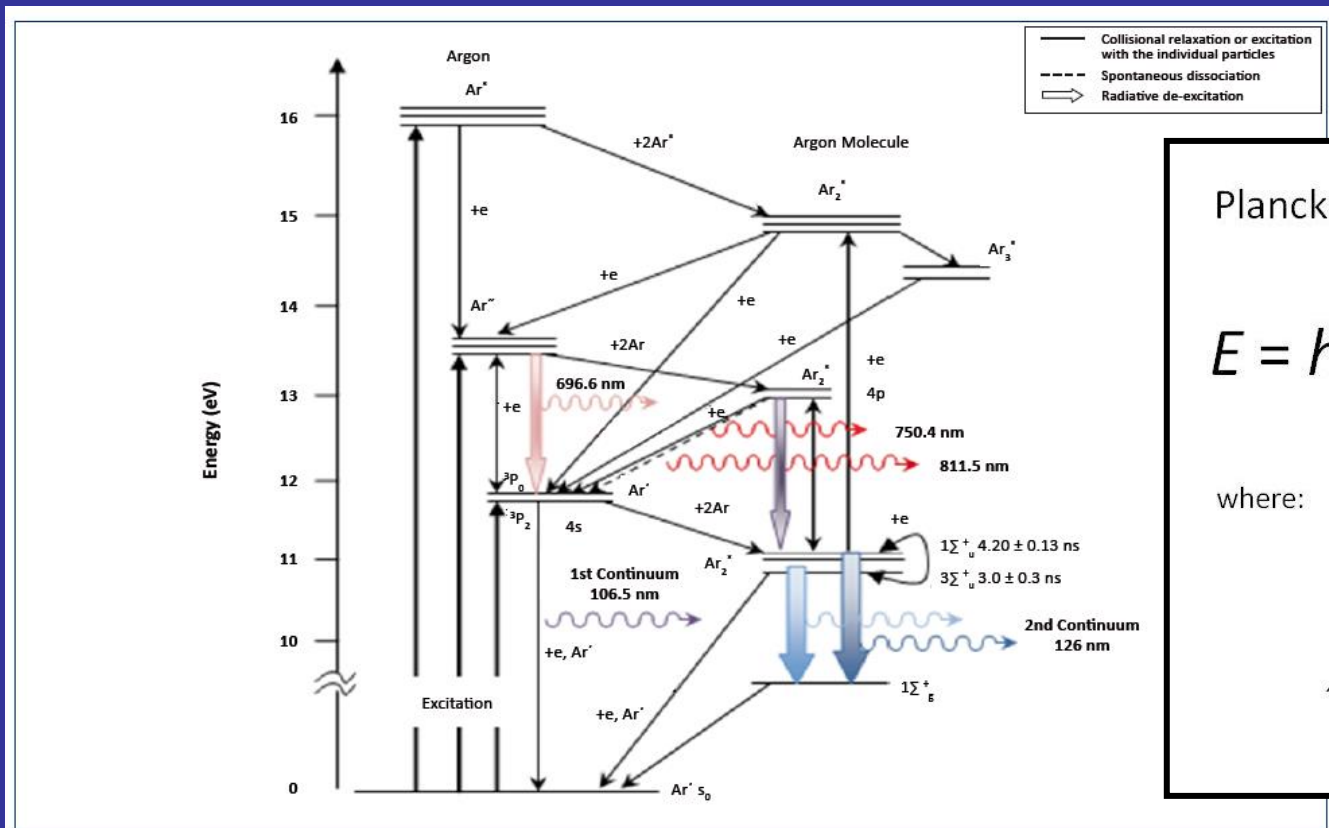

Planck relation:

$$E = h\nu = \frac{hc}{\lambda}$$

where:

- E = energy
- h = Planck constant
- ν = frequency
- c = speed of light
- λ = wavelength

The $3p^5 4s$ level is drawn as a doublet, with the non-metastable members ignored.

FIGURE 1: Energy level for atomic and molecular argon excited by a dielectric barrier discharge, showing transitions leading to the 126 nm, 750.4 nm and 811.5 nm emissions.



Erosie van kathodes





Niet vlakke objecten



3 D objecten

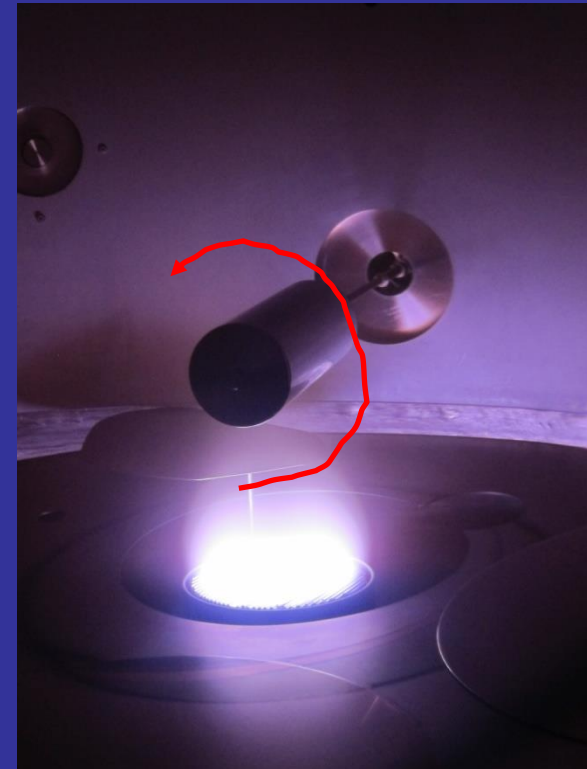

Uitwendig coaten van
cilinder



Plasma coaten in cilindrische configuratie: coaten van binnenkant cylinder

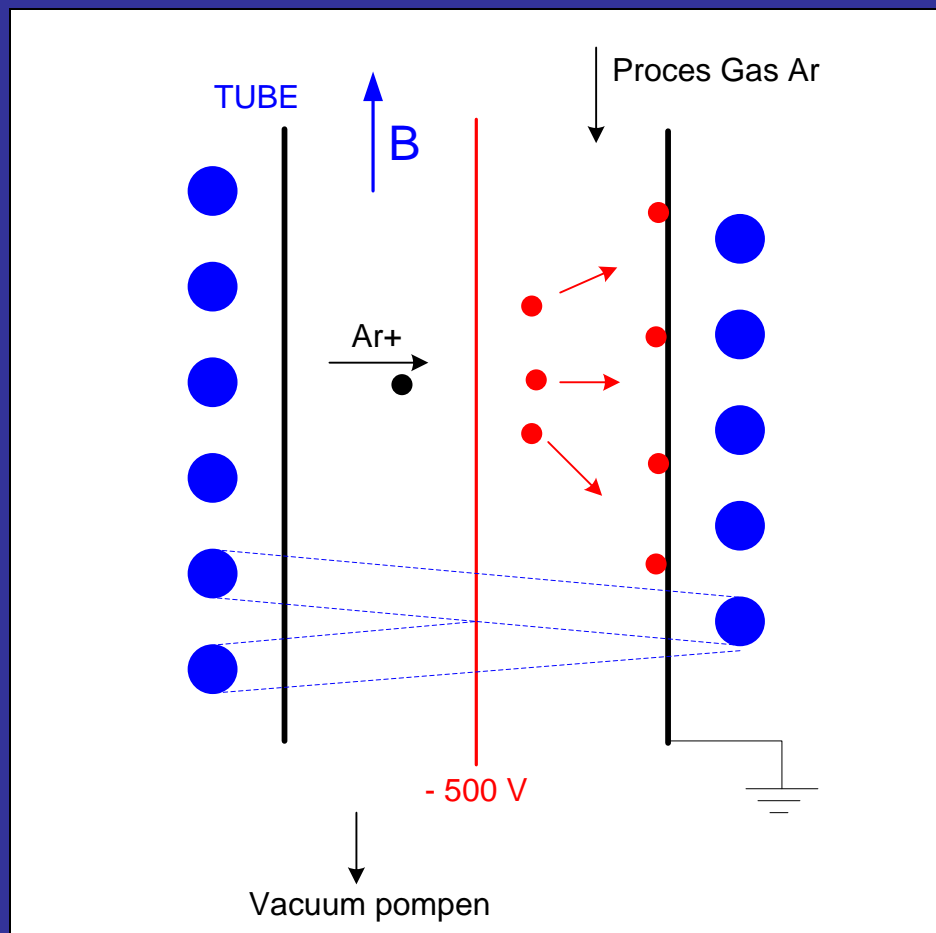

Simple examples: rectangular chamber

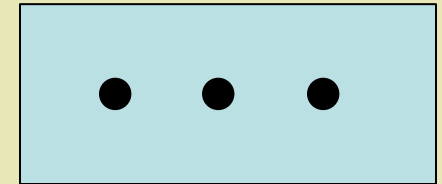
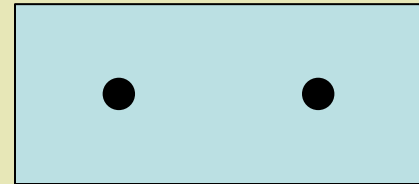
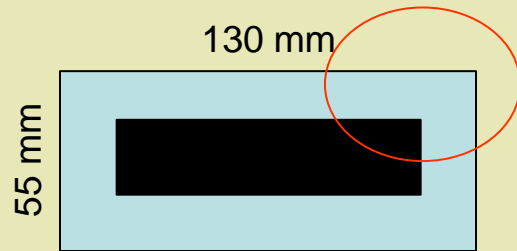

Which cathode gives the most uniform thickness profile?

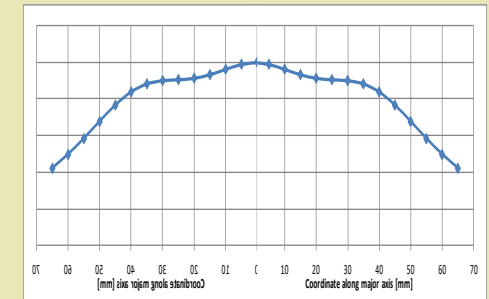
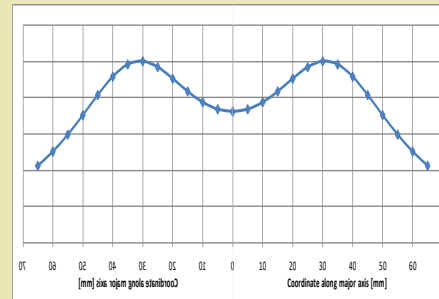
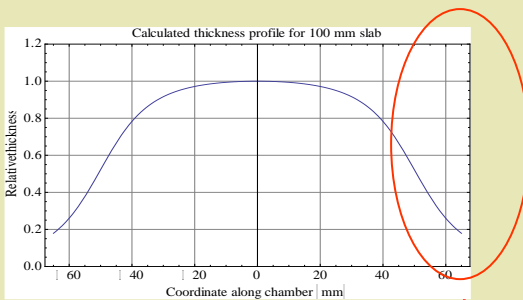

Edge effect

Advantages of coatings by sputtering

- Vacuum coatings are flexible: we can coat almost all metals, produce oxides and nitrides by chemical reactions in vacuum (adding gas)
- The atoms that make up the coatings have a large energy: this promotes adhesion, by giving activation energy for a chemical reaction to take place, and usually a good structure.
- Can be a “primer” for a galvanic coating

Disadvantages of coatings by sputtering

- Coatings only in line-of-sight: complex movements of pieces are needed, in vacuum
- The coating rate is very slow: 1 μm / hour is the order of magnitude. Because of this we need HV or UHV
- The coatings are often under stress due to the coating process itself. This goes against good adhesion.

Basic steps of thin film growth:

1. adsorption (physisorption) of atoms/molecules
2. surface diffusion
3. formation of molecule-molecule and substrate-molecule bondings (chemisorption)
4. nucleation: aggregation of single atoms/molecules
5. structure and microstructure formation (amorphous- polycrystalline - single-crystalline, defects, roughness, etc.)
6. changes within the bulk of the film, e.g. diffusion, grain growth etc.

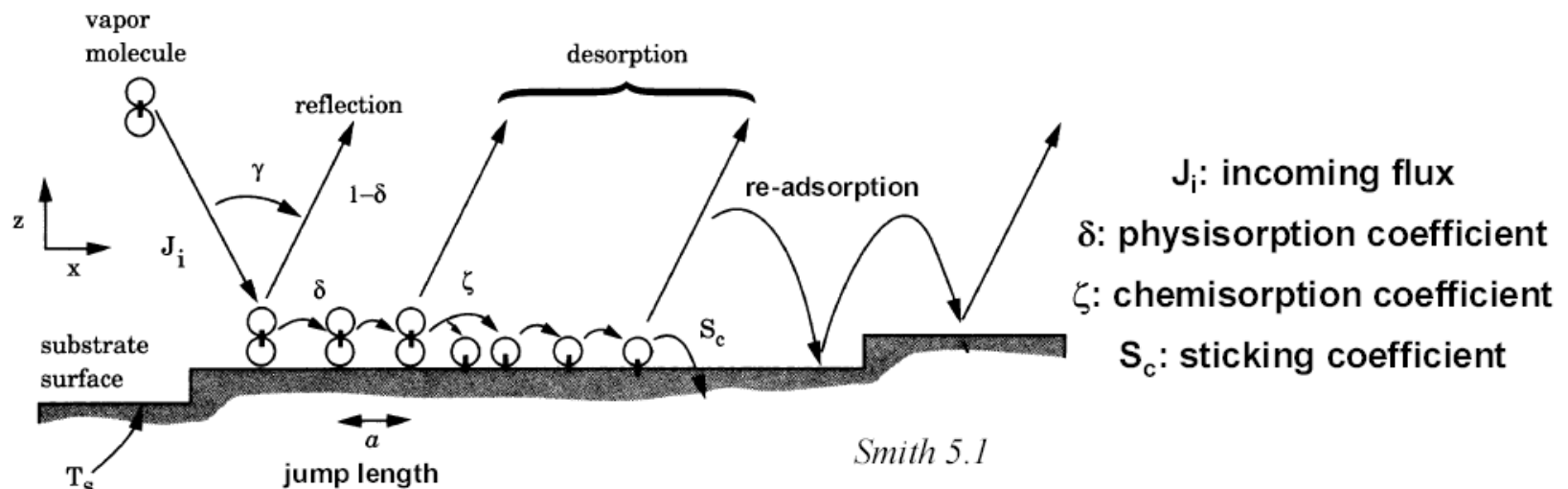

Different types of adhesion

- Chemical adhesion:
 - The film and the substrate make a chemical bond. This can be of two natures: covalent or ionic
 - Covalent: it is usually the case of a **metal film on top of an oxidised metal** (**gemeenschappelijke elektronenparen**)
 - Ionic: it is usually the case between **two metals without oxide** in between (**metaalbinding**)
- Wetting or thermodynamical or Van der Waals adhesion:
 - Two surfaces in close contact experience short range forces, which are not due to chemical actions but rather to adsorption-like phenomena.
 - Typical of **oxides on oxides, or of polymer films**
- Mechanical adhesion:
 - Roughness, interlocking of substrate and layer. Used for paints etc. Sandblasting of surfaces

More on chemical adhesion

- Example of covalent adhesion: niobium on copper
 - Enthalpy of formation: $\text{Nb}_2\text{O}_5 = -1899.54 \text{ kJ/mol}$
 $\text{CuO}_2 = -156.06 \text{ kJ/mol}$
 - Niobium has a good adhesion on copper
 - Copper has a bad adhesion on niobium!
 - Niobium can break copper oxide. The contrary will not work!!
 - Good cases: Ti/S.Steel, NEG/Cu, Ti/Al₂O₃, Al/glass
 - Bad cases: Cu/S.Steel, Cu/glass
- Ionic adhesion is stronger than covalent adhesion
 - Remove the oxide from the substrate and put pure metals in contact
 - Put first a coating which has a very good adhesion followed, without exposing to air, by the “functional” coating.
 - Example: Cu/Ti/S.steel. (Titanium is often the “magic” tool)

HiPIMS

High Power Impulse Magnetron Sputtering

The screenshot displays the genUI control interface for a HiPIMS system. The interface is divided into several sections:

- Control Panel:** Includes buttons for 'Connect', 'Disconnect', and 'Refresh'. The system is identified as 'Magn2 (master)'.
- Voltage Controls:** Negative voltage is set to 488 V, and positive voltage is set to 100 V. Both are accompanied by 'Enable' toggle switches set to 'ON'.
- Status Indicators:** Board statuses are 'ok / ok / ON'. Radiator temperature is 29.8 °C. Fan mode is 'auto adjust | max'. Arc number is 2. Arc event is 'overcurrent'. Charge system state is 'ready'.
- Mode Selection:** Magnetron mode is 'Pulse | DC'. Pulse mode is 'Both polarities | Negative only'. Parallel mode is 'Single | Independent | Dependent | Bias'. Master/Slave is set to 'Master | Slave | Off'.
- Configuration Parameters:** Operating time is 370 ms|s|m|h. Energy limit is ∞ J|kJ|MJ. Delay after arc is 100 μs|ms|s. Max arcs is 100000.
- Start Control:** A 'Start' toggle switch is set to 'ON'.
- Advanced Settings (Red Box):** Frequency is 1000 Hz, Negative pulse is 50 μs, Interpulse is 4 μs, and Positive pulse is 200 μs.
- Power Settings:** 'Stabilize negative source: voltage | power' is set to 'power: 400 W'.
- Real-time Plot:** A graph showing current (I, A) and voltage (V, V) over time (t, μs). The current shows a sharp negative peak of approximately -44.2 A during the pulse.
- Summary Statistics:** Current peak: -44.2 A, Current avg: -26.1 A, Voltage peak: -492.6 V, Voltage avg: -491.4 V, Power: 388 W, Pulse energy: 0.388 J, Total energy: 2057754.3 J, Pulses done: 5262405.

= Power DC →

power: 400 W

	negative	positive	Σ
Current peak:	-44.2 A	2.9 A	
Current avg:	-26.1 A	0.4 A	
Voltage peak:	-492.6 V	98.4 V	
Voltage avg:	-491.4 V	97.6 V	
Power:	388 W	11 W	399 W
Pulse energy:	0.388 J	0.011 J	
Total energy:	2057754.3 J	59062.6 J	
Pulses done:	5262405		

HiPIMS

High Power Impulse Magnetron Sputtering

DCMS: Cu atomen
HiPIMS: > Cu ionen

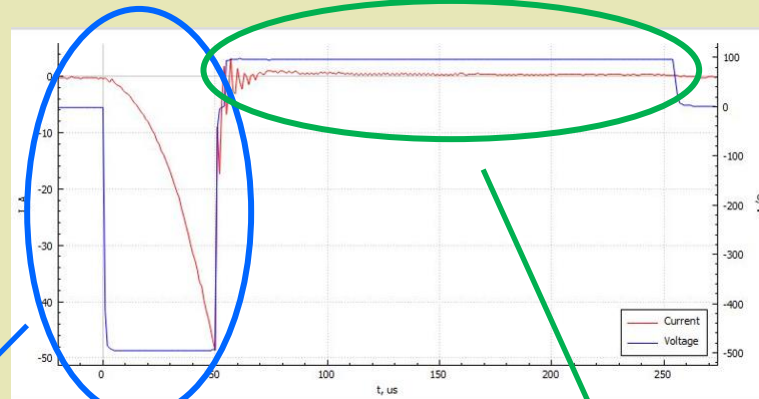

Negative puls: sputtering

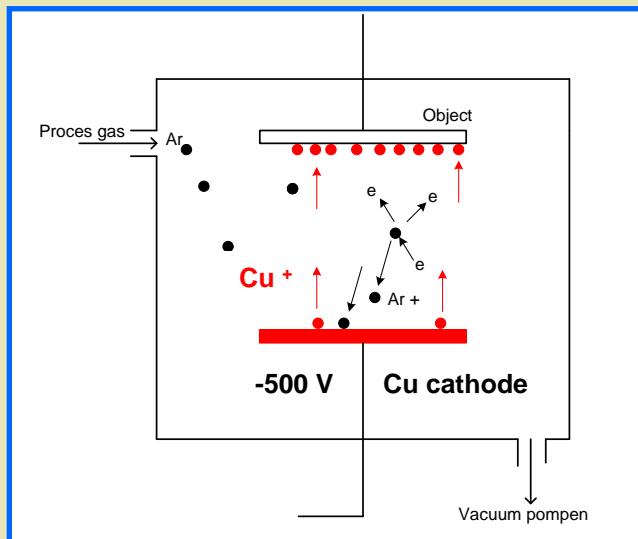

Positive puls: transport of Cu ionen: kick energy

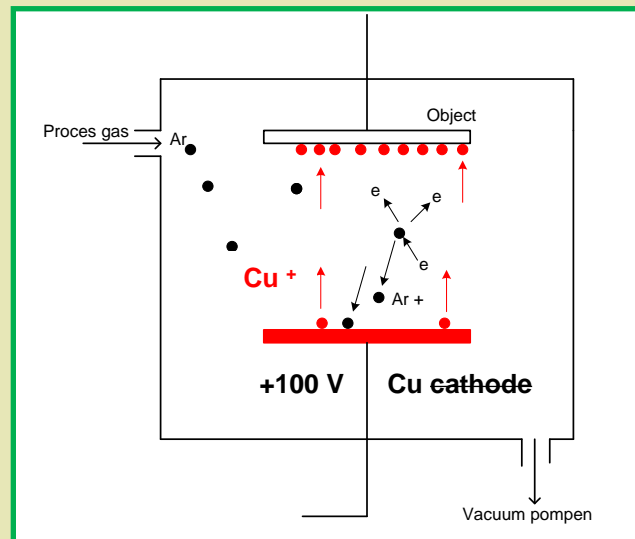

Thin films in CERN accelerators: Nb for accelerating cavities

Superconducting Radio Frequency (SRF) acceleration

Challenges for FCC -ee:

- Improve Q_0 for Nb films at higher Eacc

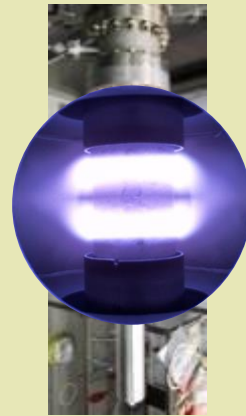

DC
magnetron

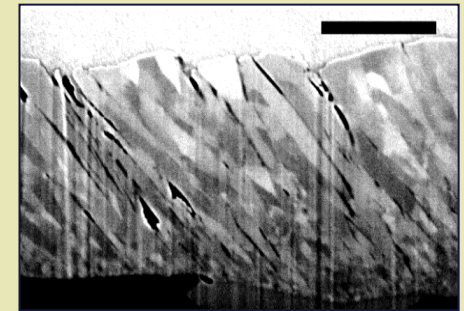

HiPIMS

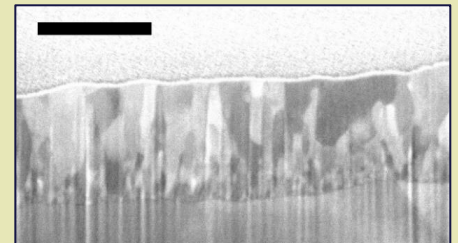



Voorbeelden van coatingen in industrie



Harde / slijtvaste coating



lage wrijvings-coëfficiënt



lage transmissie

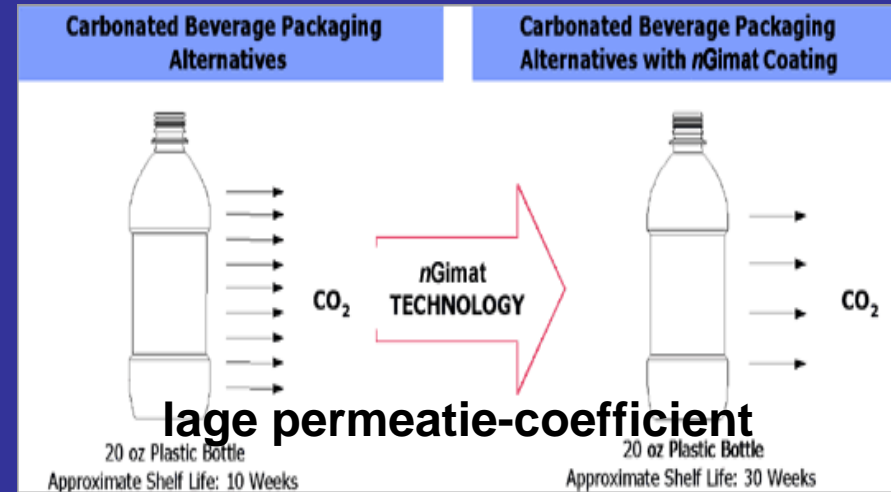



Voorbeelden van coatings in industrie

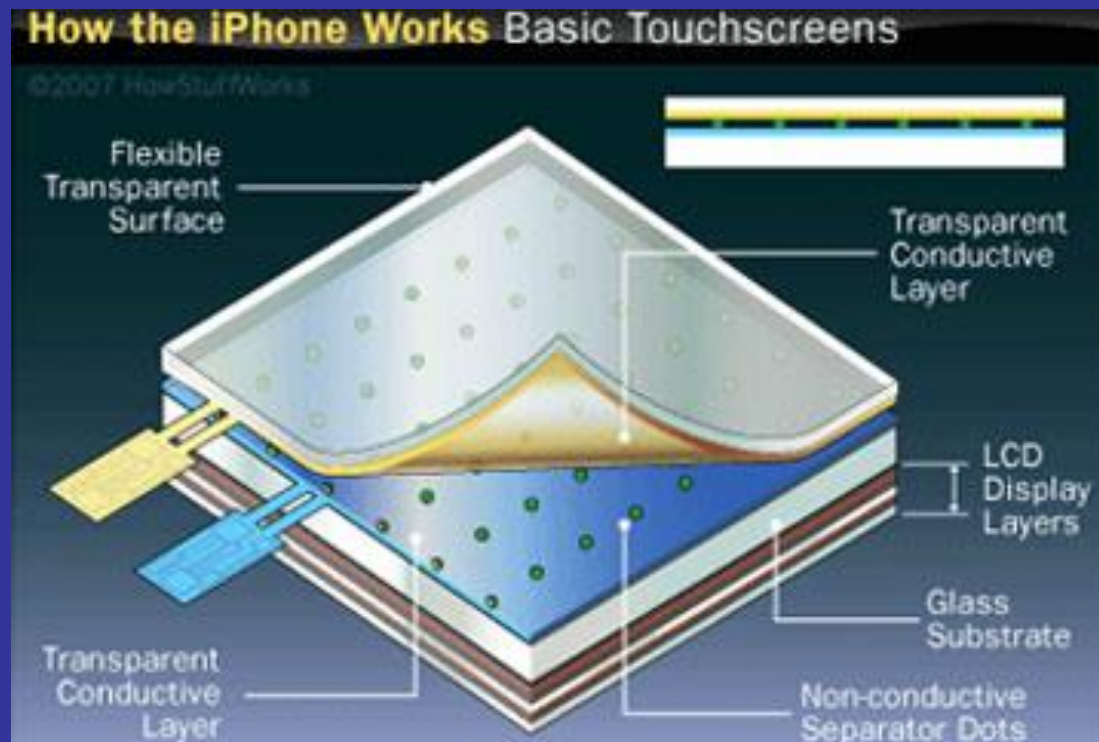



Een ander toepassing op CERN :
NEG COATING: pompende coating

LHC: Beam pipe: Pressure $< 1 \cdot 10^{-11}$
mbar ($1 \cdot 10^{-9}$ Pa)





What is a Non Evaporable Getter (NEG)? Materiaalkunde

A NEG material presents a reactive surface to some gas species, adsorbing (*gettering*) impinging molecules.

Once saturated, the *gettering* activity ceases and no more gas is pumped.

The NEG can then be regenerated by heating to its activation temperature during a certain time.

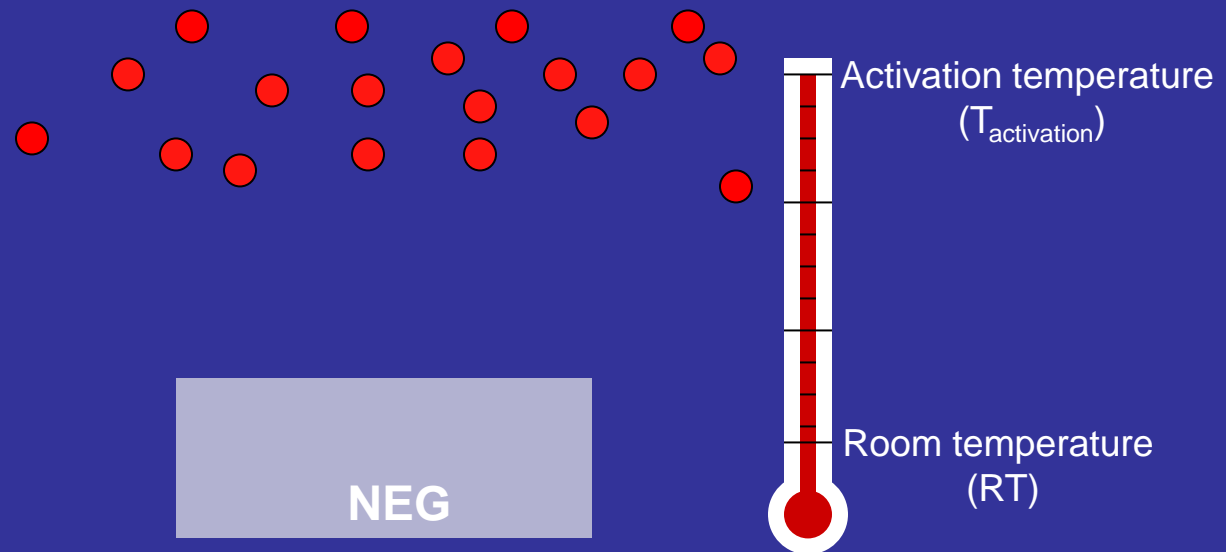



What is a Non Evaporable Getter (NEG)?

A NEG material presents a reactive surface to some gas species, adsorbing (*gettering*) impinging molecules.

Once saturated, the *gettering* activity ceases and no more gas is pumped.

The NEG can then be regenerated by heating to its activation temperature during a certain time.

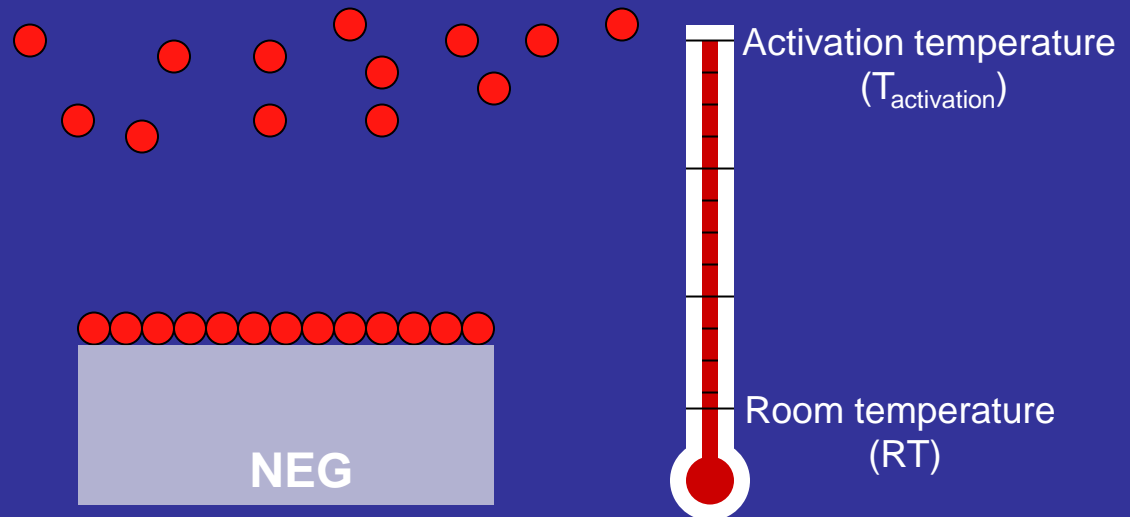

Back to room temperature (RT) the NEG recovers its pumping capabilities.



The solution was to integrate the vacuum pump in the beam pipes by inserting a strip of NEG. This NEG strip could be activated by resistive heating and pump molecules desorbed all along the beam pipe.

Cross section of the LEP dipole vacuum chamber

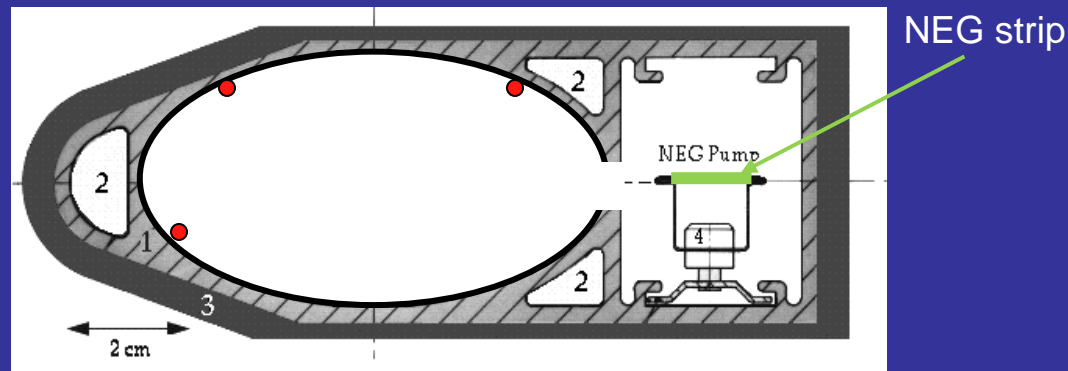



The solution was to integrate the vacuum pump in the beam pipes by inserting a strip of NEG. This NEG strip could be activated by resistive heating and pump molecules desorbed all along the beam pipe.

VOOR LHC

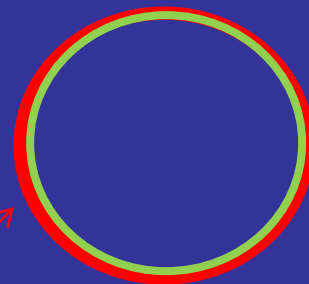

Cross section of the LEP dipole vacuum chamber

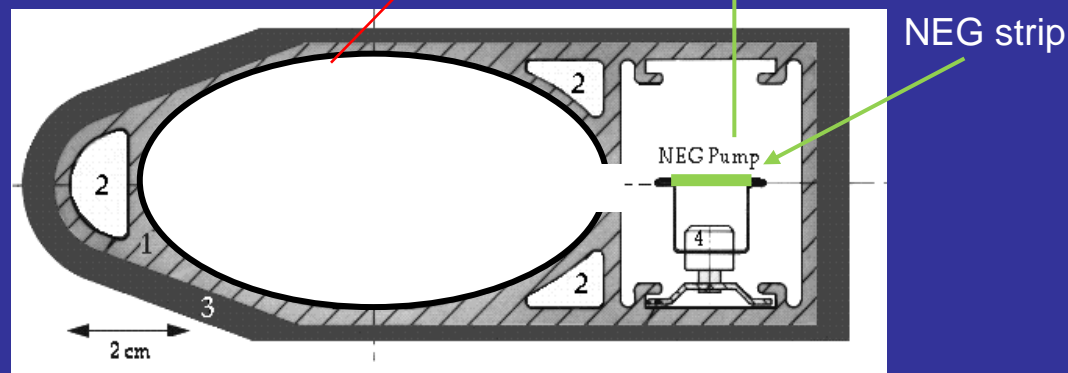



R & D

Research:

- legering met een “lage” activatie temperatuur.

De laagste activatie temperatuur is gevonden in een ruim gebied van composities met:

Titanium, Zirconium en Vanadium

en is 180 °C ; 24 uur

- onderzoek naar coating parameters (T , Power, Gasses)
 - Lange termijn effecten (activatie cycli)



This NEG thin film is obtained by bombarding a target made of inter twisted wires of titanium, zirconium and vanadium, with ions. The atoms of the target are then sputtered and deposited in the beam pipe walls.

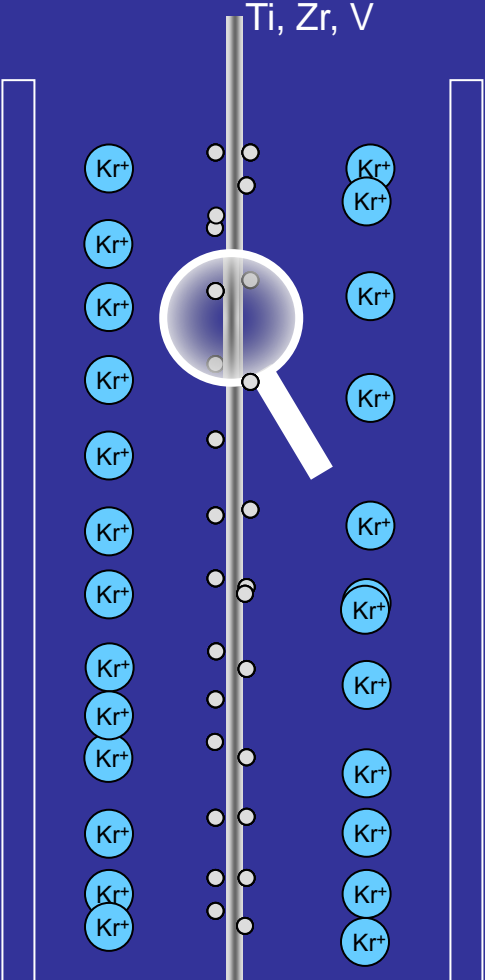

beam pipe wall

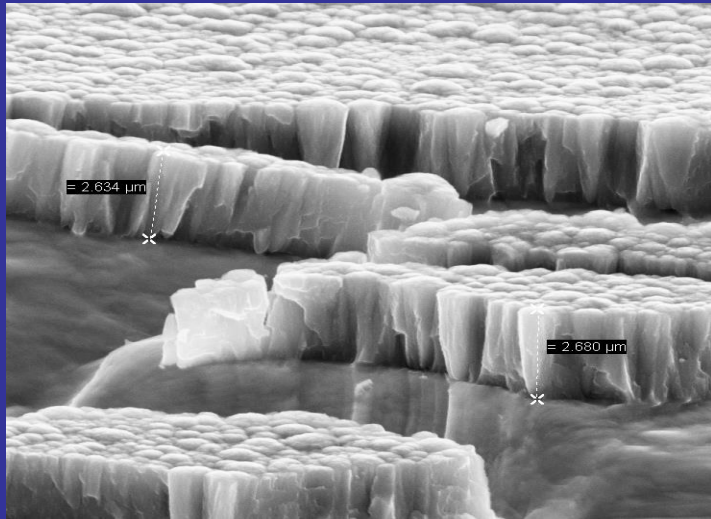
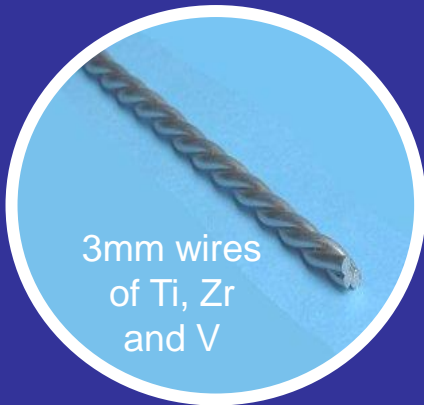



Totale project:

van Research tot
installatie in LHC

≈ 7 km NEG coated

10 jaar

5 mensen

Version française ci-dessous

PR03.23
27.09.2023

ALPHA observes the influence of gravity on antimatter

Geneva, 27 September 2023. Isaac Newton's historic work on gravity was apparently inspired by watching an apple fall to the ground from a tree. But what about an “anti-apple” made of [antimatter](#), would it fall in the same way if it existed? According to Albert Einstein’s much-tested theory of general relativity, the modern theory of gravity, antimatter and matter should fall to Earth in the same way. But do they, or are there other long-range forces beyond gravity that affect their free fall?

In a [paper](#) published today in *Nature*, the [ALPHA](#) collaboration at CERN’s Antimatter Factory shows that, within the precision of their experiment, atoms of antihydrogen – a positron orbiting an antiproton – fall to Earth in the same way as their matter equivalents.

The “de-accelerator” where the antiprotons are prepared is fully coated with NEG.

2- Thin films in CERN accelerators: NEG for vacuum (and e-cloud)

NEG thin films widely used in synchrotron light sources

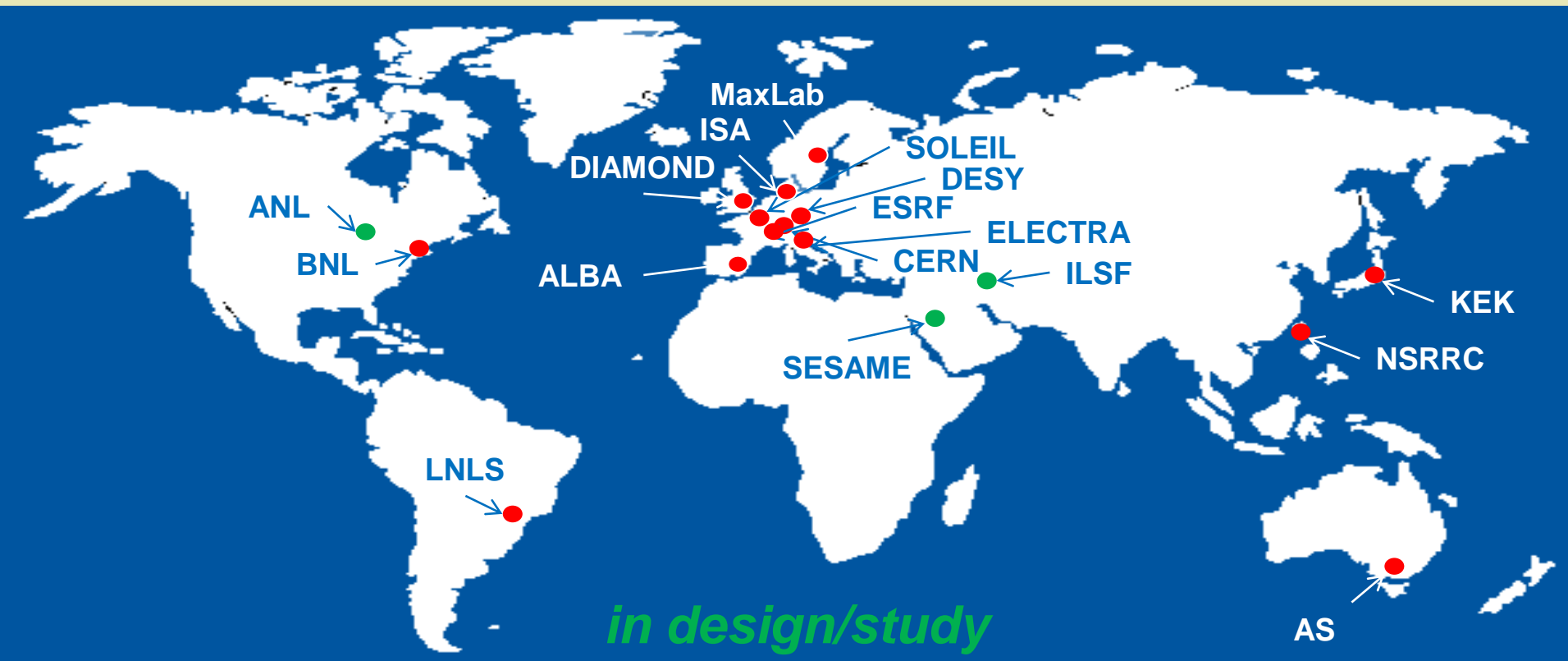



Wat nu :LHC werkt

“upgrade” van LHC: HL-LHC
diverse onderdelen

Onderdrukking van Electronen
emissies van pijpwanden in voor
versnellers (SPS: 1976 , 6.9 km):

Mogelijke oplossing:

Koolstof coating

1. Introduction / Motivation; why?

The formation of electron clouds in particle accelerators.

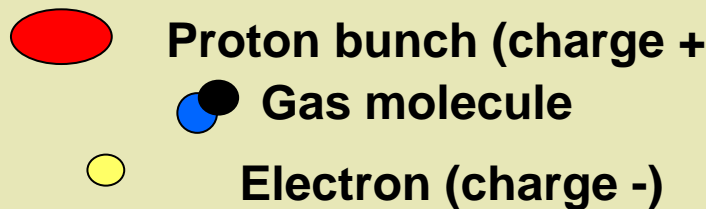

Proton bunch (charge +)
Gas molecule
Electron (charge -)

$$\text{Secondary electron Yield (SEY)} = \frac{\text{Number of emitted electrons}}{\text{Number of impinging electrons}}$$

1. Introduction / Motivation; why?

Threshold for SEY for e-cloud: Depending of geometry, and energy

For SPS different geometries

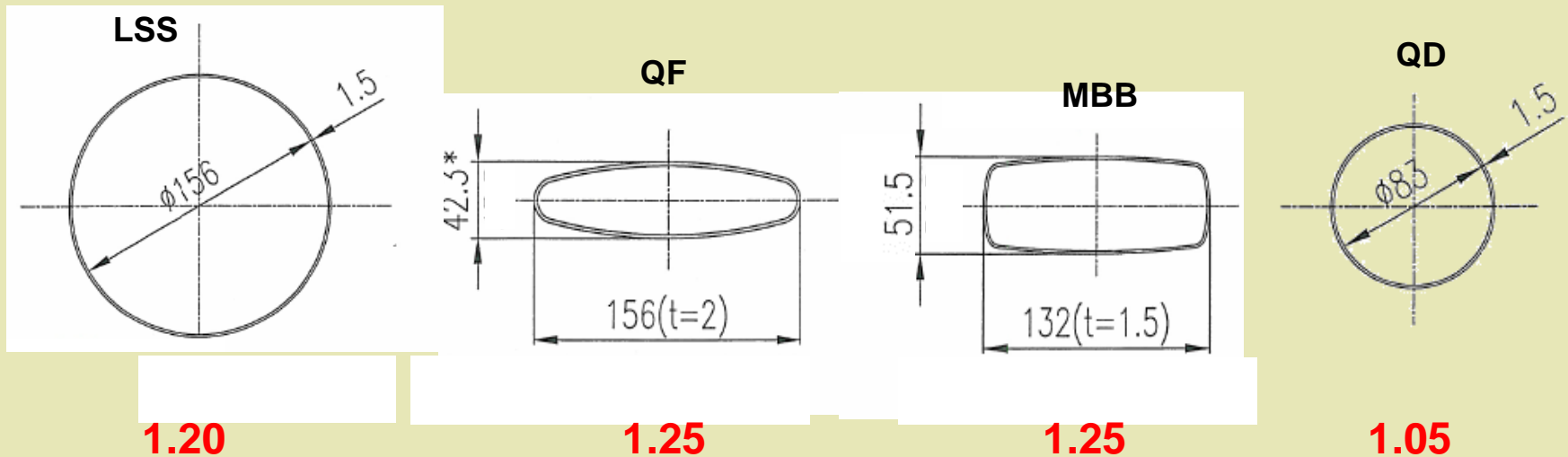

*: Giovanni Iadarola: LIU SPS scrubbing review; 8-9 September 2015, values for “worst” case scenario

2. Method: How?

Development of carbon coatings (from 2007)

Why carbon? **➔** Graphite has a low SEY (secondary electron yield)

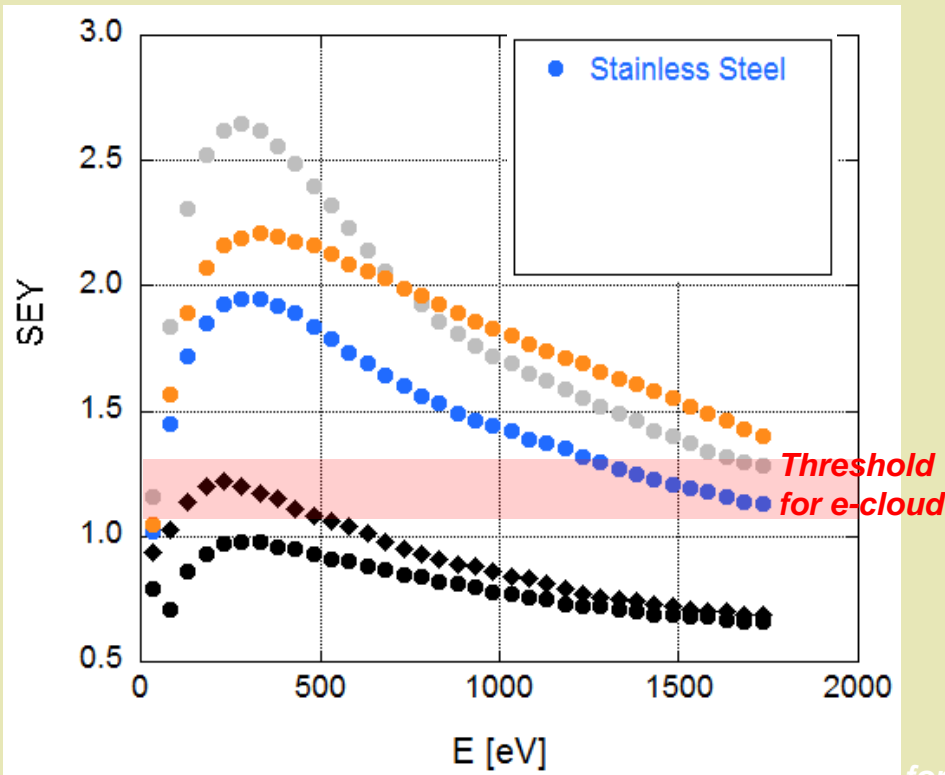

Alternatives:

Clearing electrodes

LESS

(Laser Engineered Surface Structures)



Ontwikkeling van Carbon coatings in vacuum pijp

Test opstelling in lab: 2013-2016





Ontwikkeling van Carbon coatings in vacuum pijp

Test opstelling in lab: 2013-2016

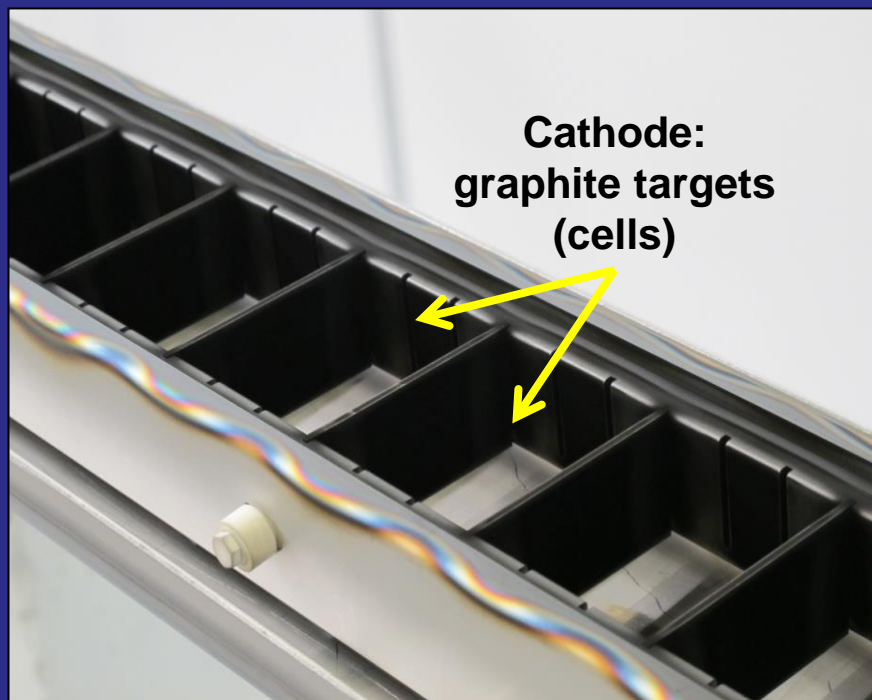

**Cathode:
graphite targets
(cells)**



6.5 meter



Ontwikkeling van Carbon coatings in vacuum pijp

Test opstelling in lab: 2013-2016

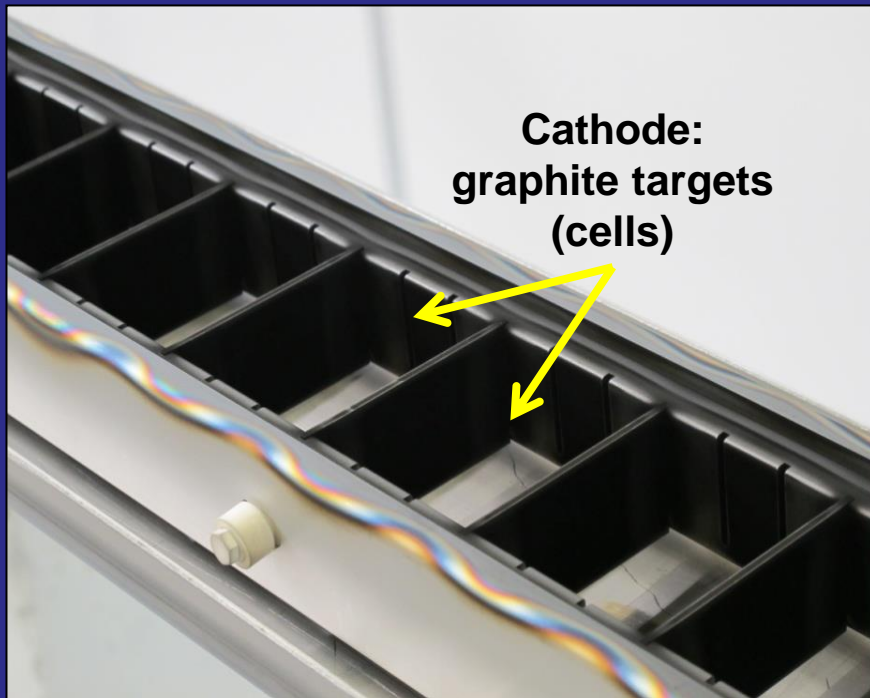



Ontwikkeling van Carbon coatings in vacuum pijp

Test opstelling in lab: 2013-2016

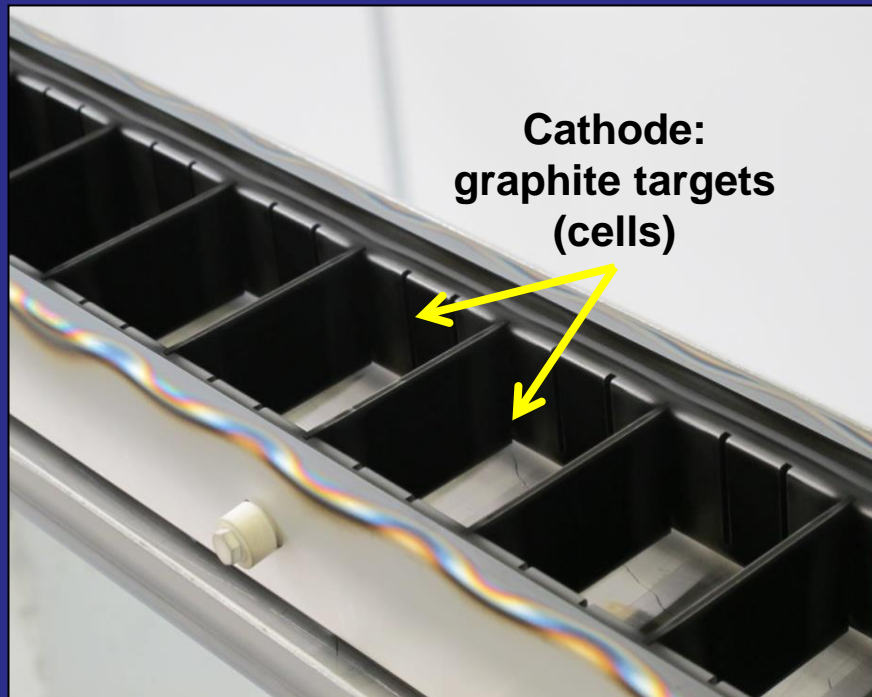

**Installed in SPS:
GOOD RESULTS**

Plan voor LS2: 2019-2020: coat magneten in tunnel



QF

SSS

MBB

MB 2-31

SPS ARC :
Herhaling van cell van 64 m
Niet mogelijk QF / MBB te verplaatsen

LS2: coating of alle QF + small magnets

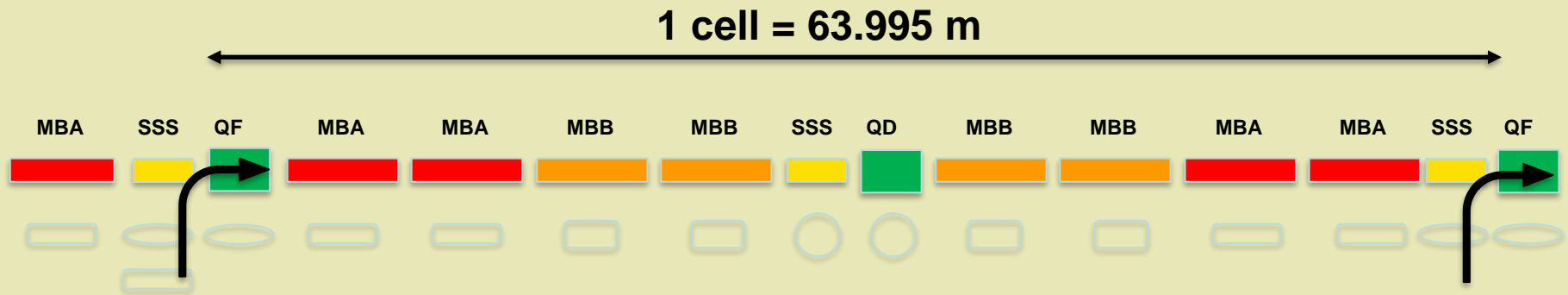

Coating lab in surface building



+ drifts to 181

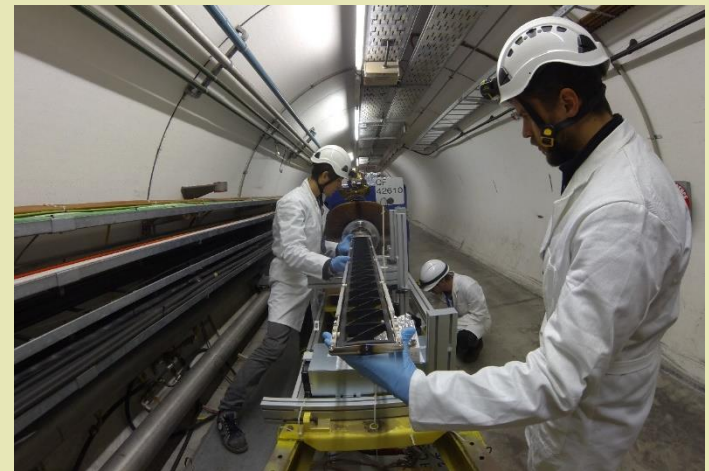



In situ Carbon coatings in SPS



2017: 8 grote Magneten MBB

9 "kleine" QF

2018: 3 grote Magneten

2019-2020: LS2

- 88 QF

- 102 magn. in lab

SPS operationeel sinds 2022: goede resultaten mbt elektronen-wolk reductie

2- Thin films in CERN accelerators: a-C (anti-multipacting)

Challenges & Opportunities?

High Luminosity LHC: anti-multipacting to reduce the heat load to superconducting magnets.

Very restricted clearance:
150 mm gap to insert coating device
to coat 12 m long tubes

Ti & aC coating:
Ti for adhesion and
pumping of hydrogen

