

WP3: Vacuum

Jose A. Ferreira Somoza and Alice Michet (TE-VSC)

9th of february 2026

PUMA requirements: Trap requirements

- Pumping on cold surfaces (4.2K) of gases entering the trap
- Maximum allowed pressure at the entrance of the trap \Rightarrow Defined by expansion of gas
- Only H₂ and He pressure will evolve with time \Rightarrow Sub ML coverage
- Small conductance between the entrance and collision and storage trap.

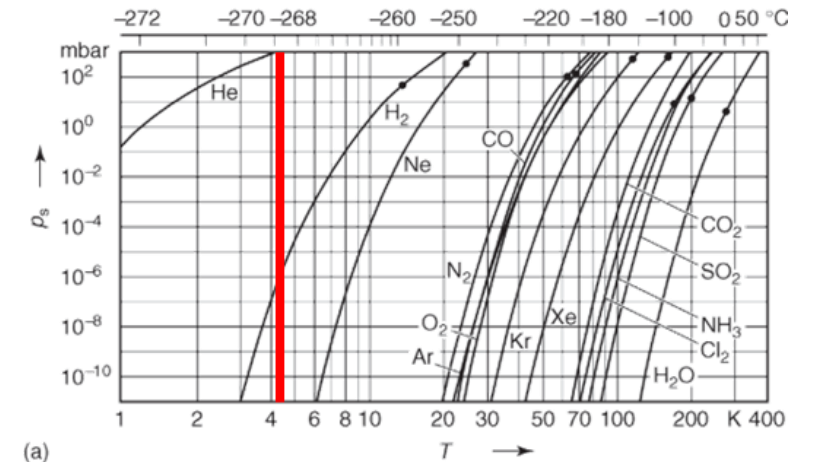
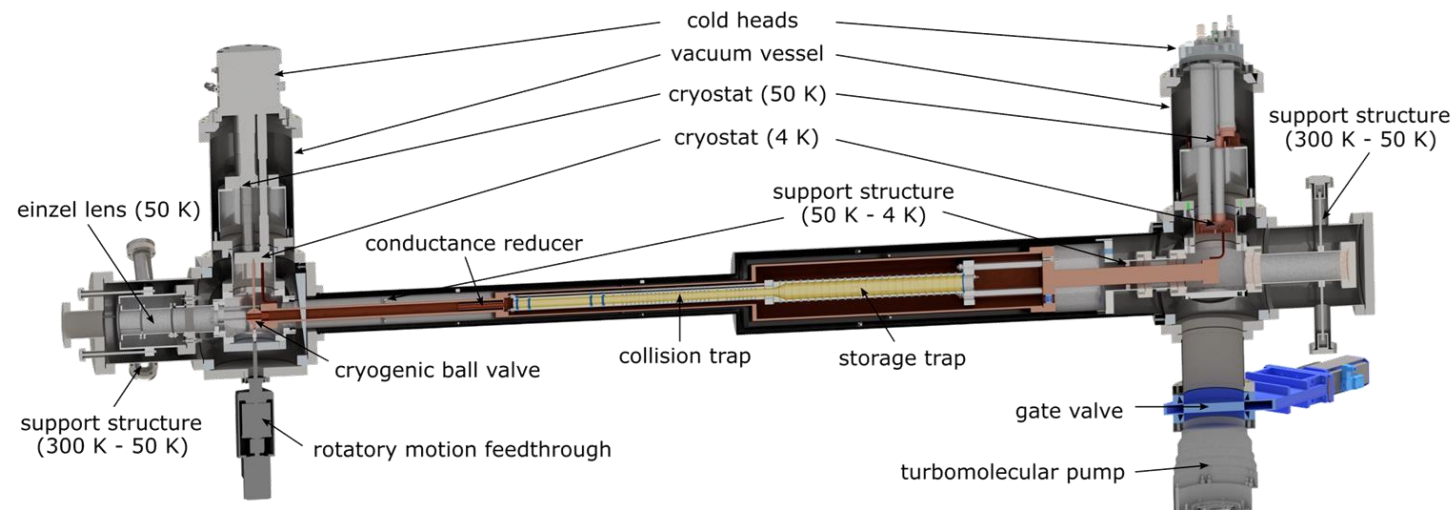

(a)

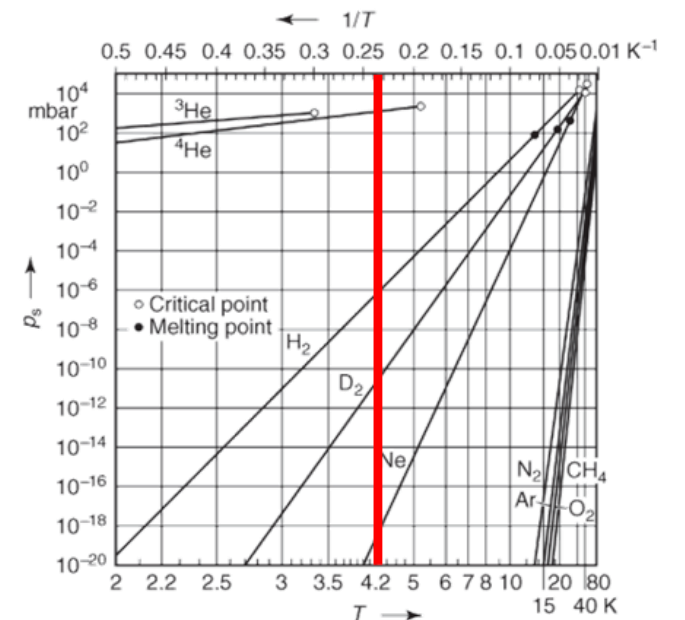

(b)

PUMA layout

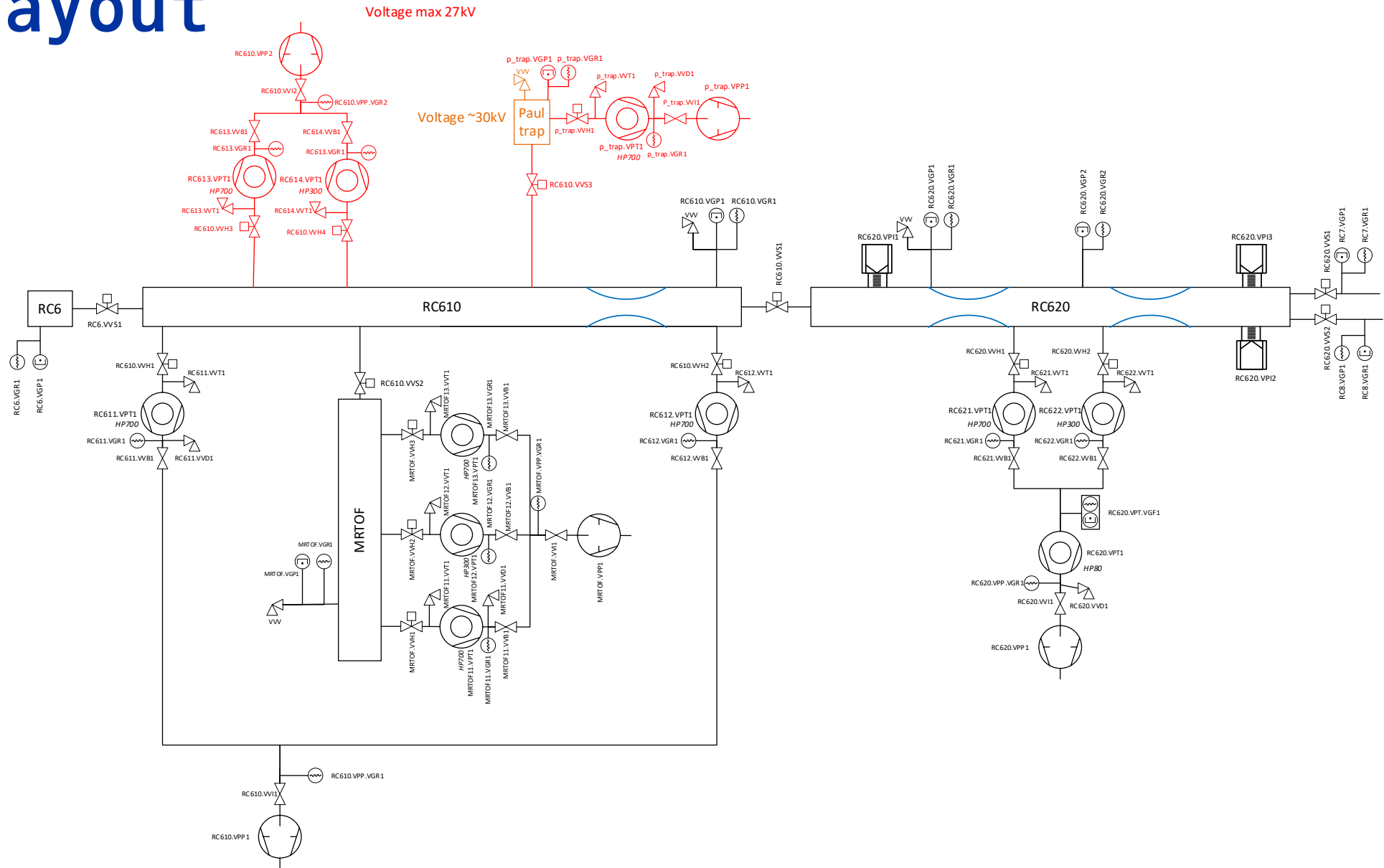

PUMA layout: Sectorization

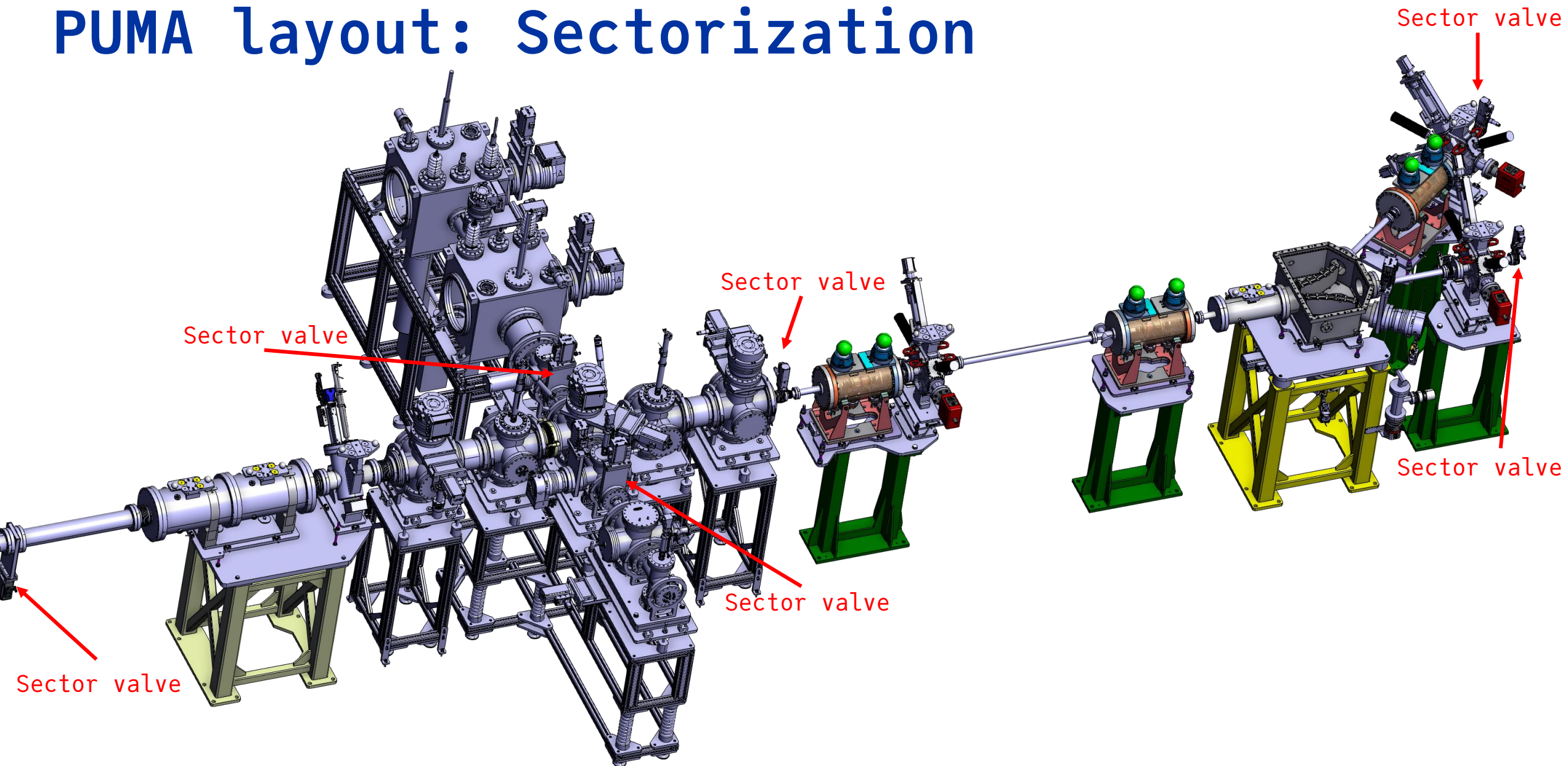

PUMA layout: RC610

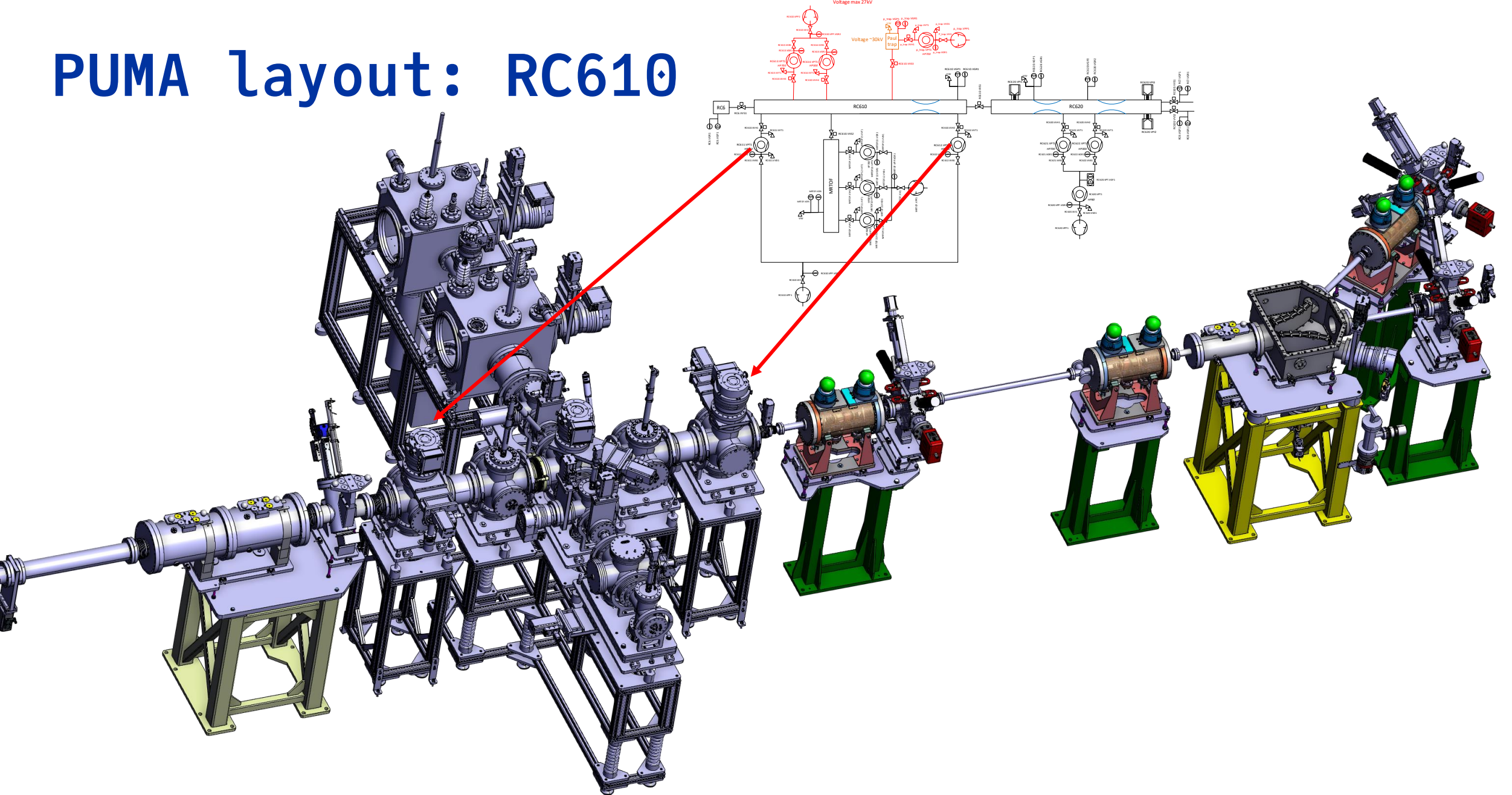

PUMA layout: RC610

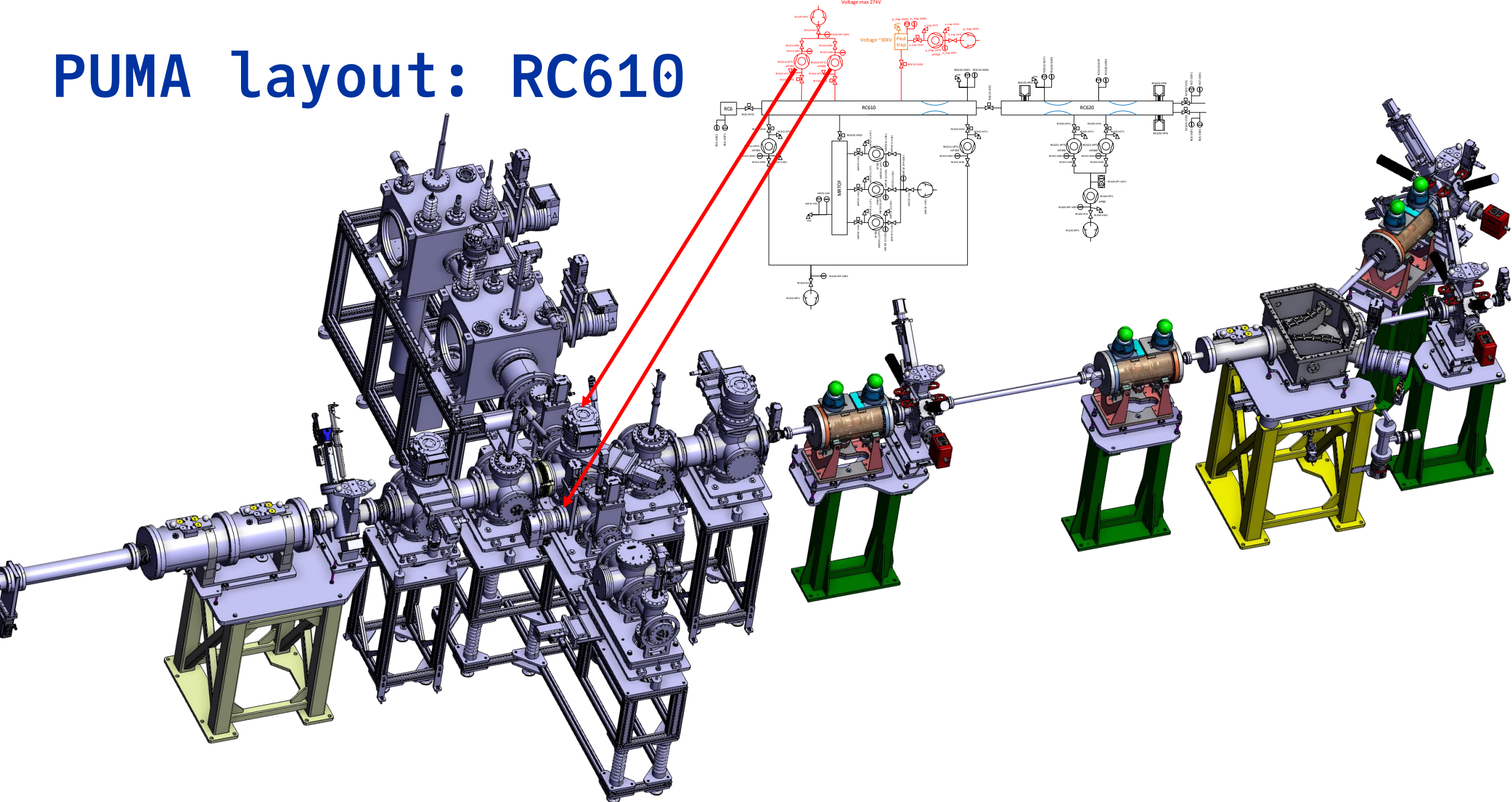

PUMA layout: MRTOF

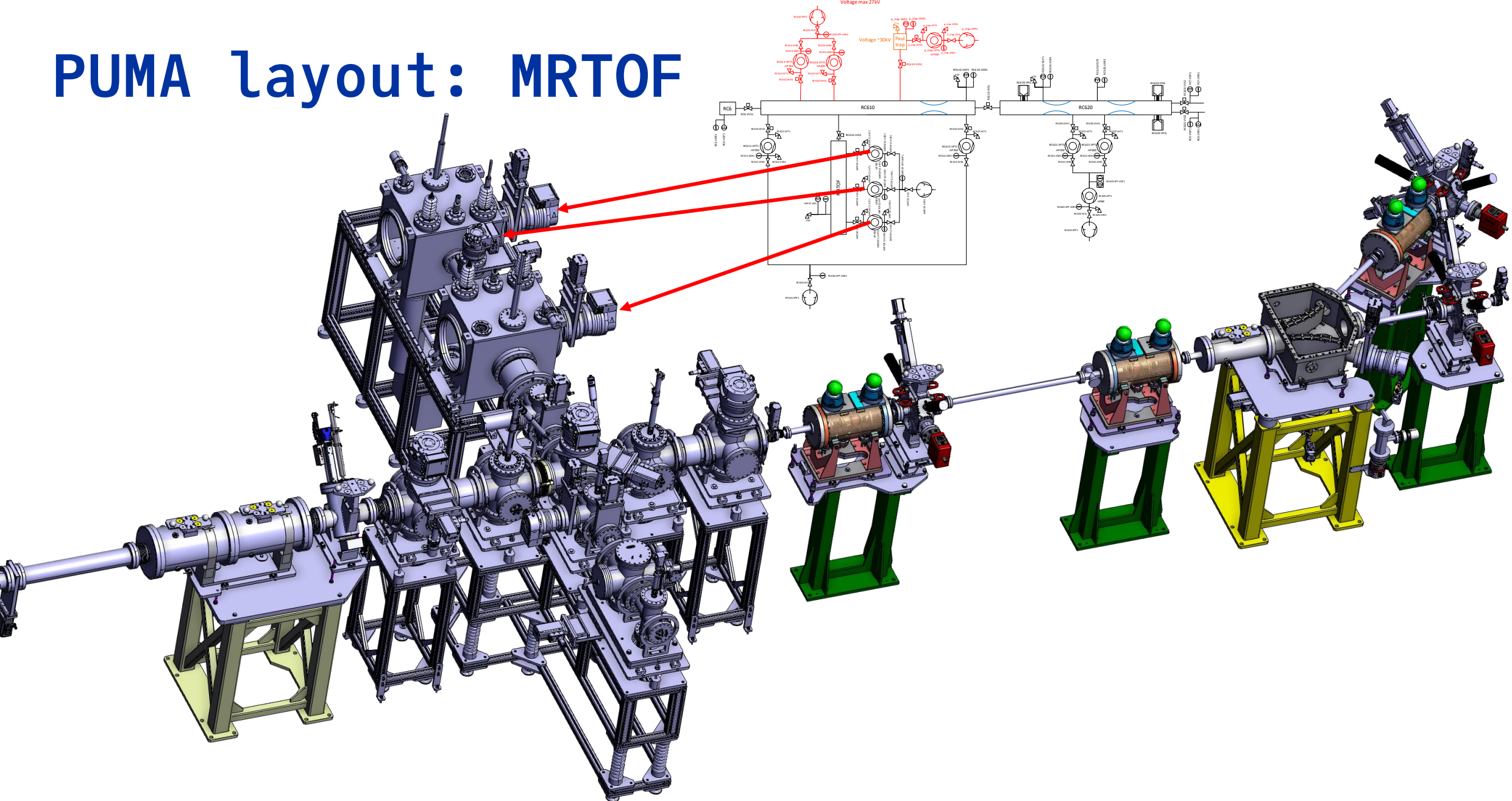

PUMA layout: PT

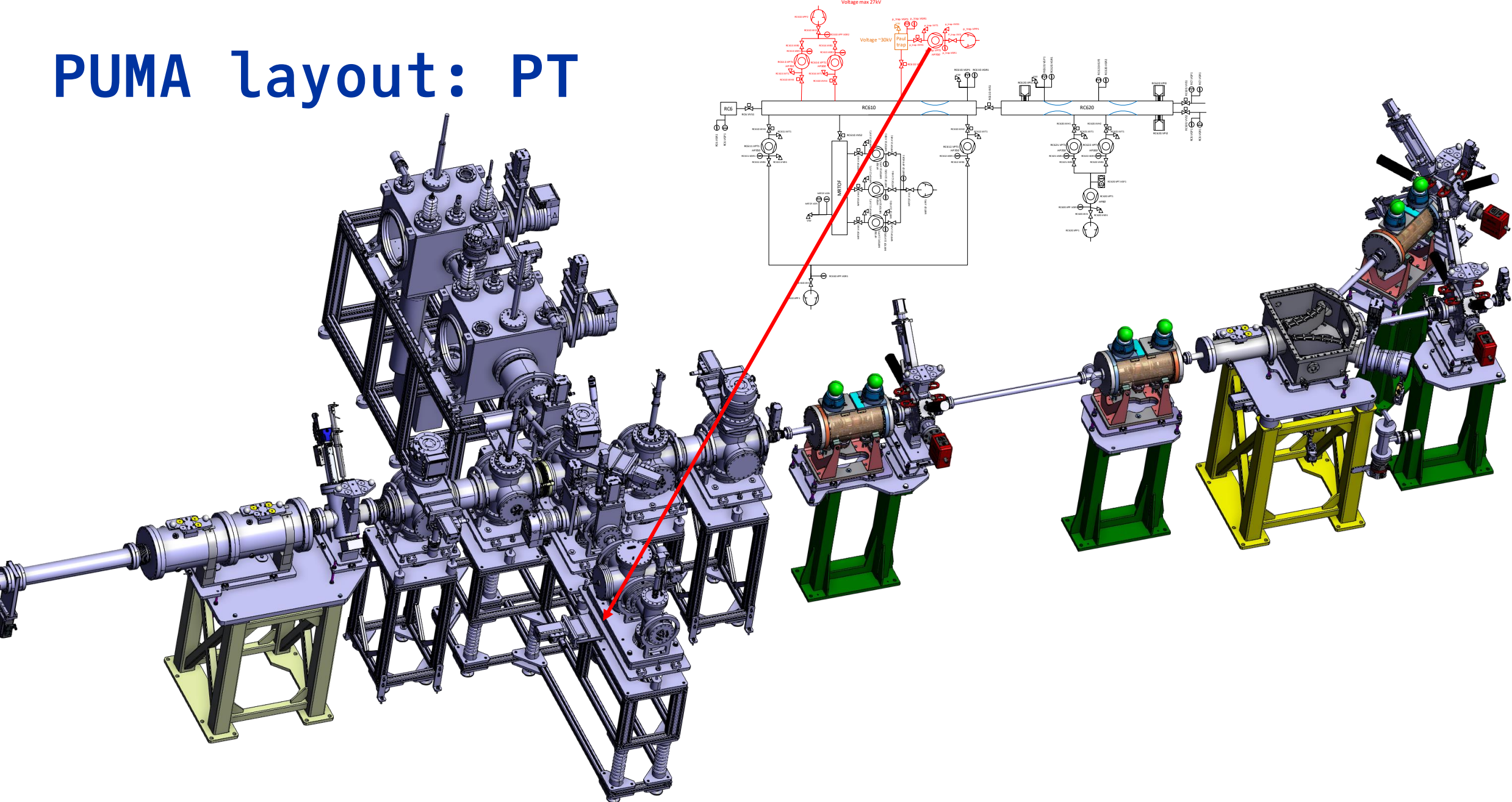

PUMA layout: RC620

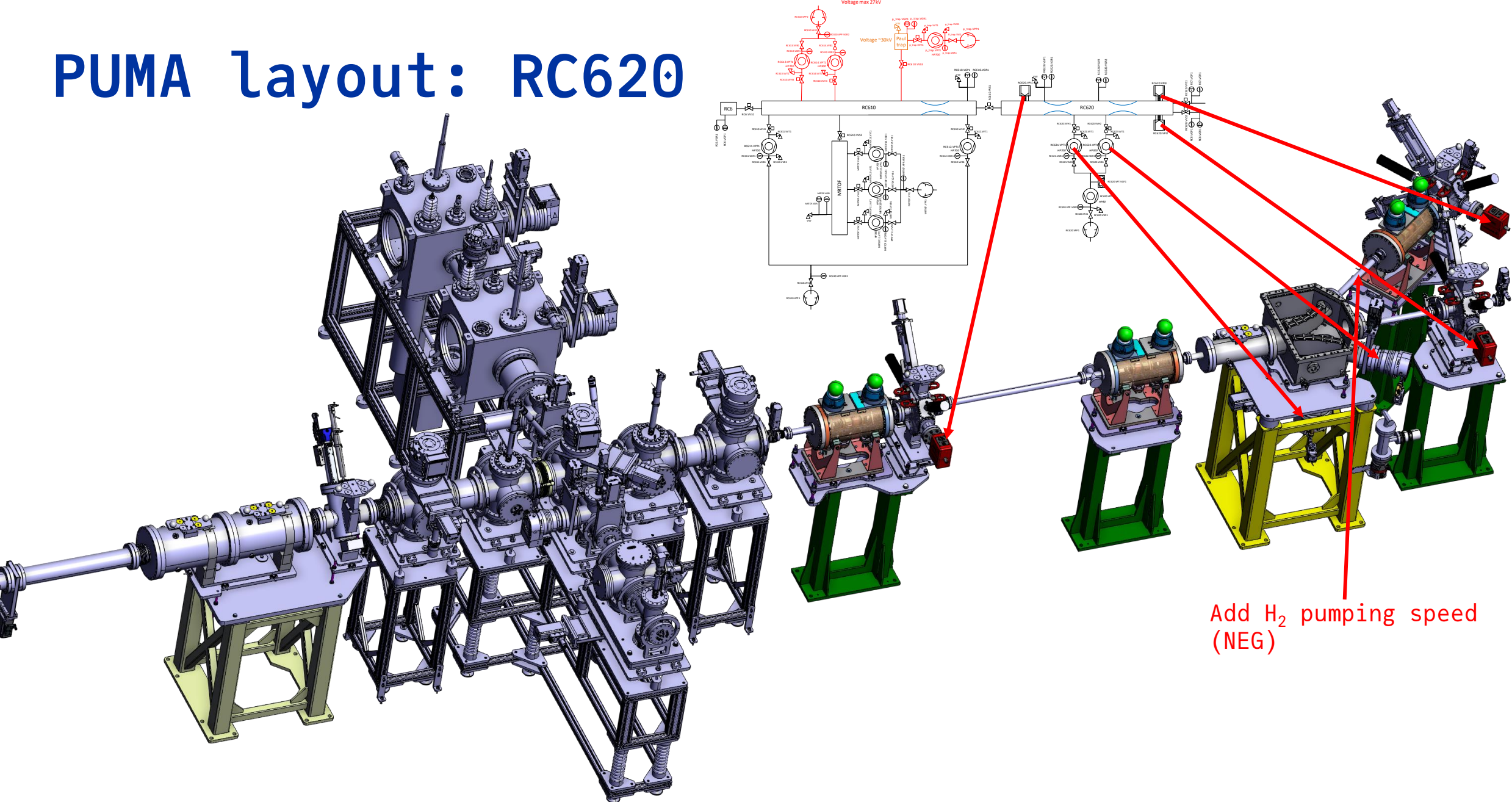

PUMA layout: RC620

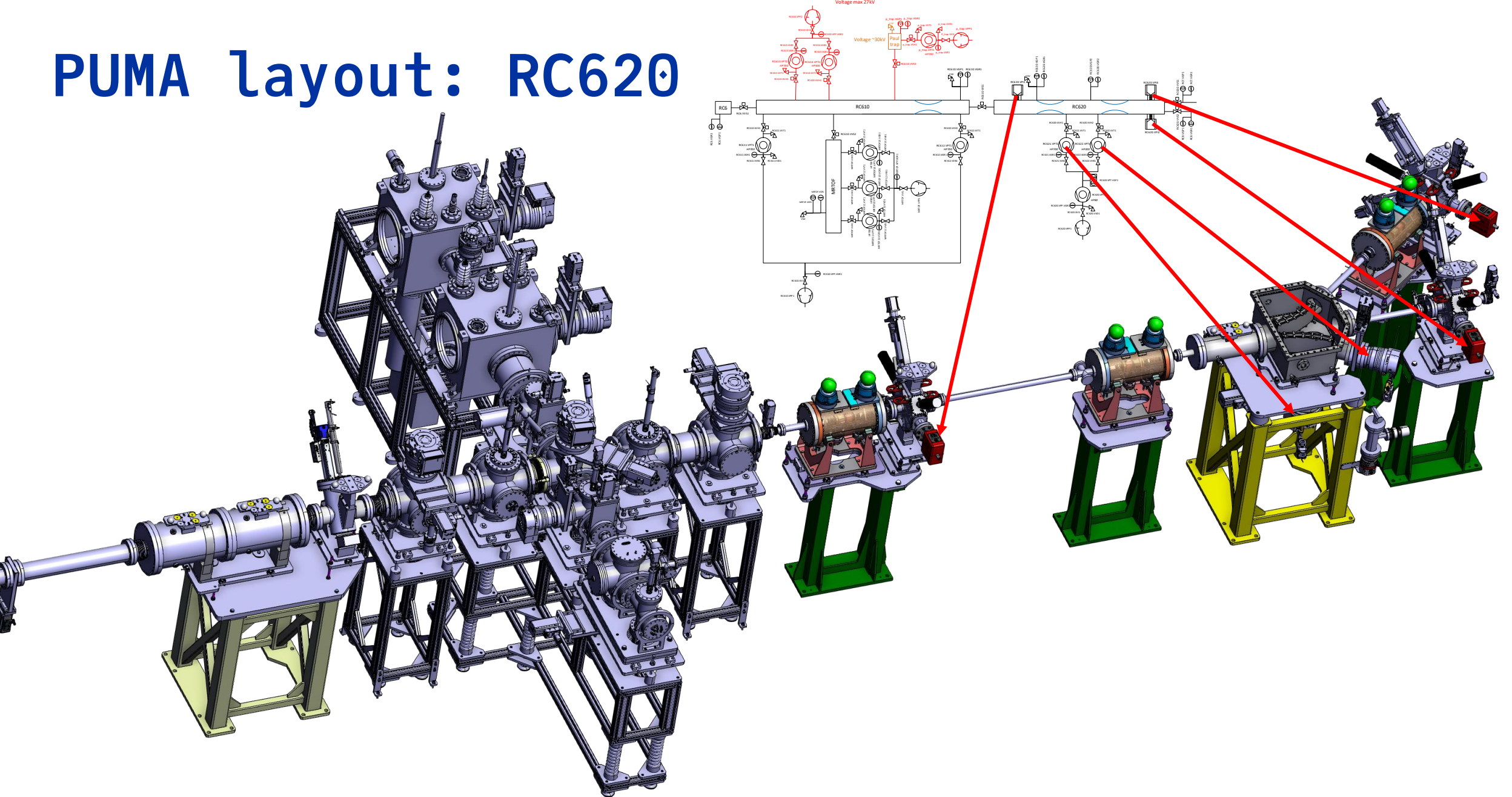

PUMA simulations

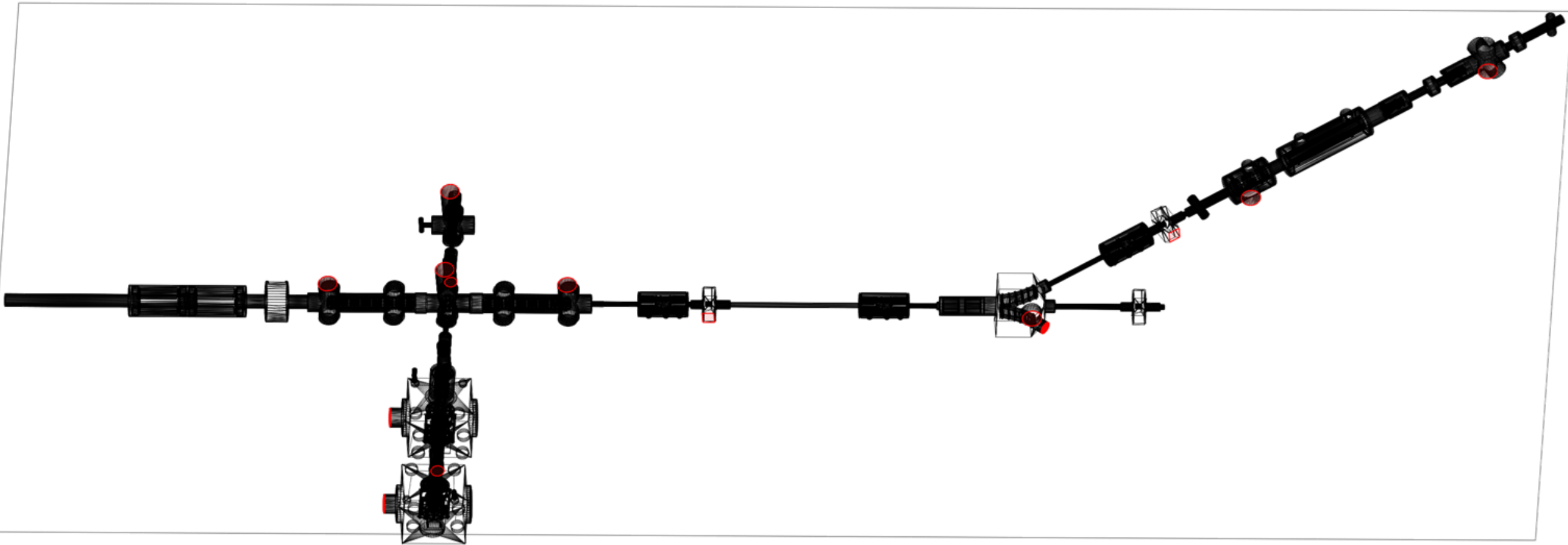

PUMA beam line requirements

- ❑ **Input: Paul trap with He injection at 10^{-4} mbar (absolute) \Rightarrow Inside the trap pressure is $>10^{-2}$ mbar!**
- ❑ Main concern is the He propagation.
- ❑ He pumping strategy:
 - ❑ (many) turbopumps along the beam line
 - ❑ ion pumps next to the trap at very low pressure.
- ❑ H_2 easier to treat. Its pumping speed can be progressively increased to cope with the outgassing gas loads in the vicinity of the trap. Starting with turbopumps and ending with ion pumps and NEG cartridges and coatings

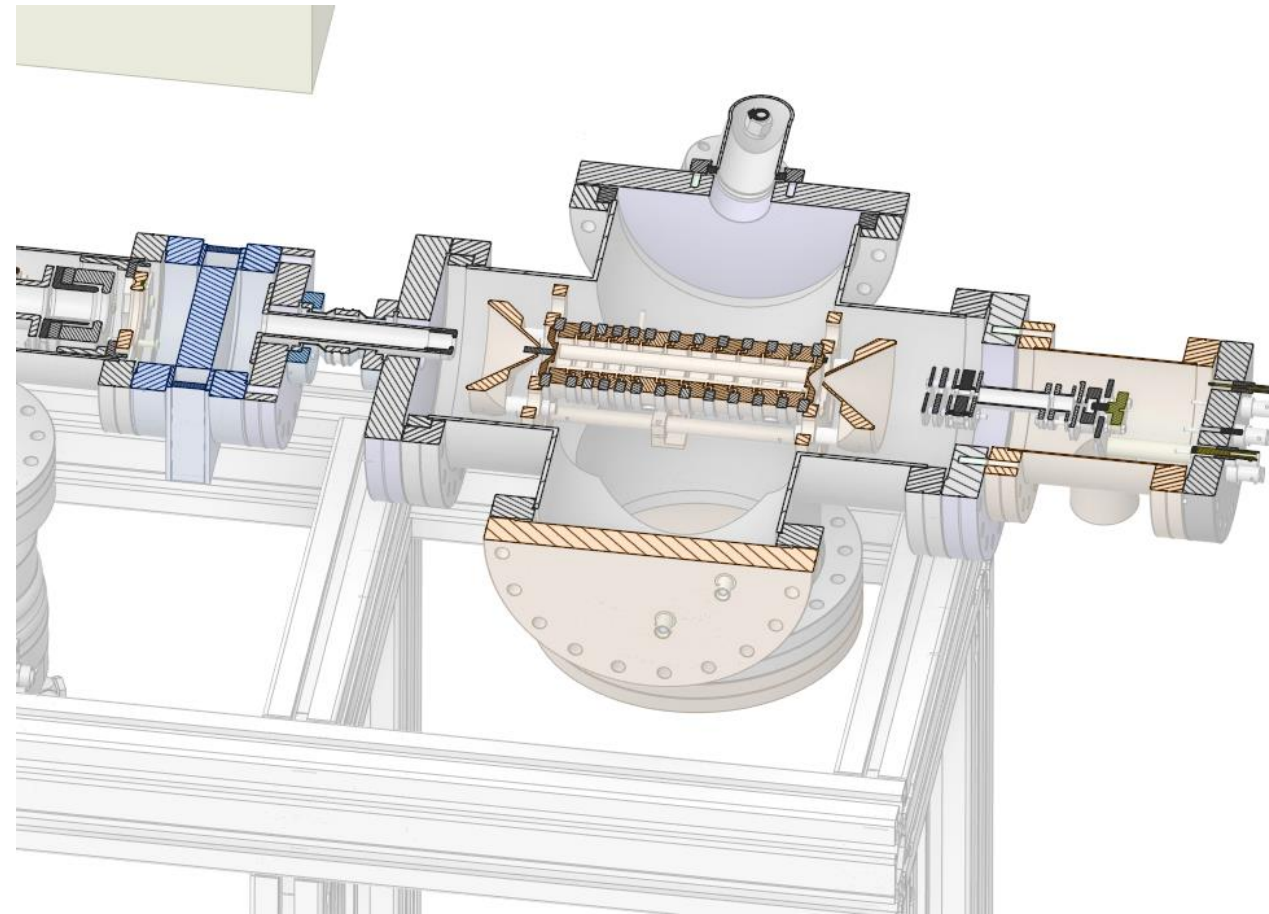

Test at MIRACLs

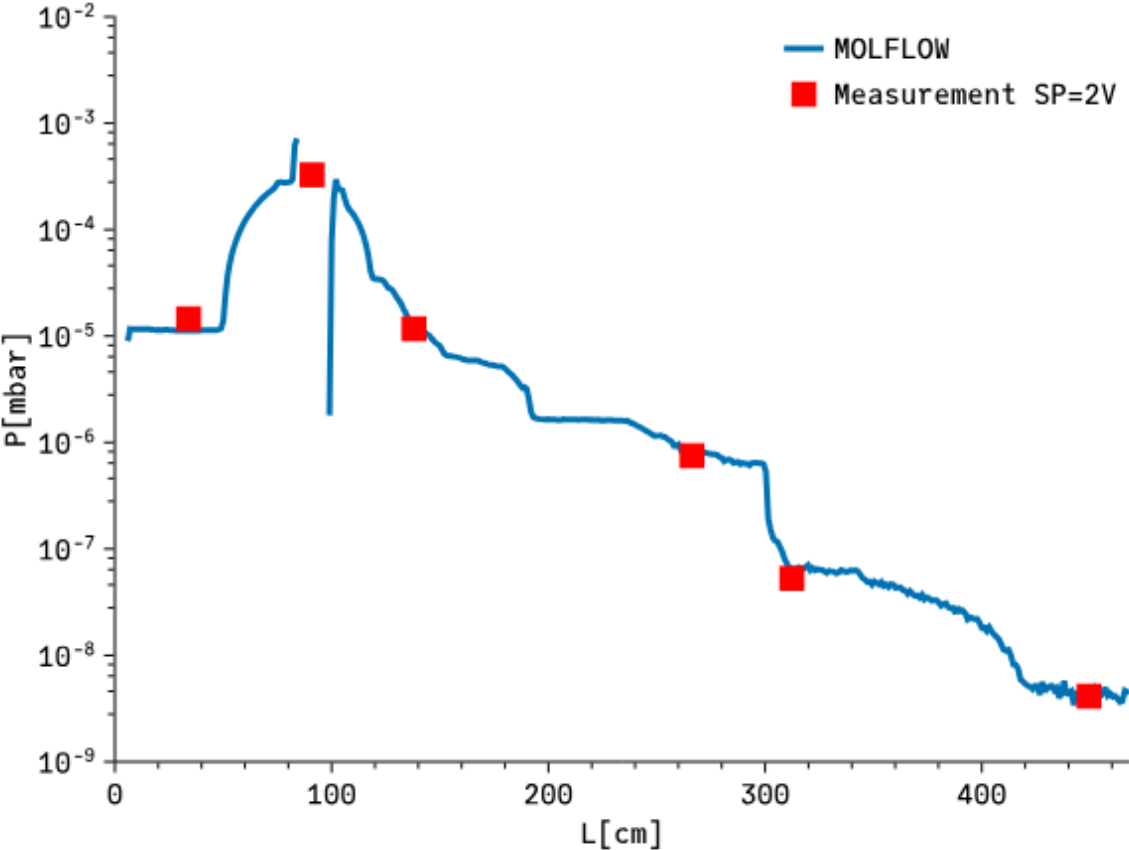

With calibrated leak discrepancy of approx. 5% between simulation and real value => Compression ratio has to be considered => Exhaust

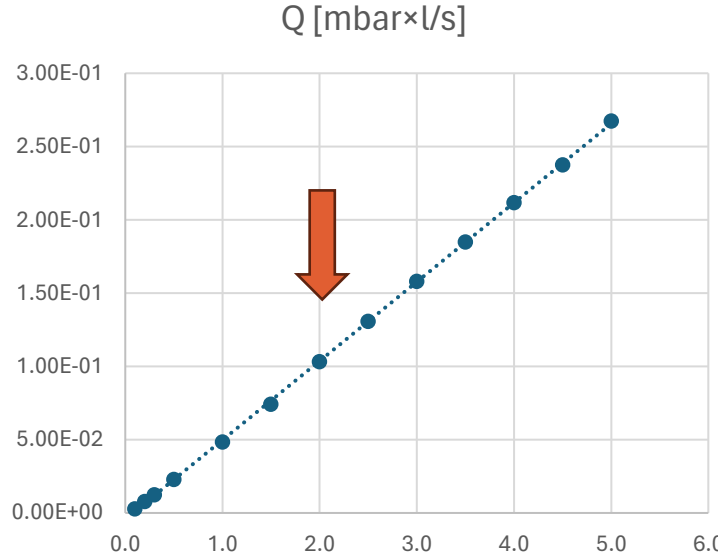
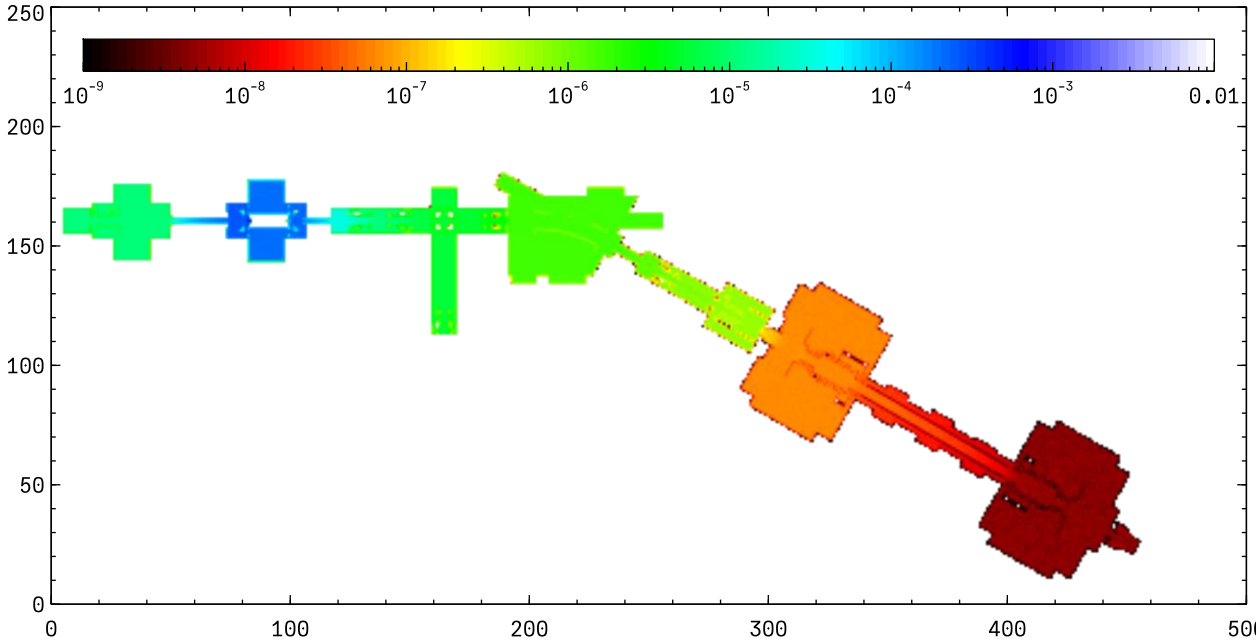

SP[V]	Q [mbar×l/s]
0.1	2.74E-03
0.2	7.68E-03
0.3	1.24E-02
0.5	2.30E-02
1.0	4.84E-02
1.5	7.41E-02
2.0	1.03E-01
2.5	1.31E-01
3.0	1.58E-01
3.5	1.85E-01
4.0	2.12E-01
4.5	2.38E-01
5.0	2.67E-01

Iris

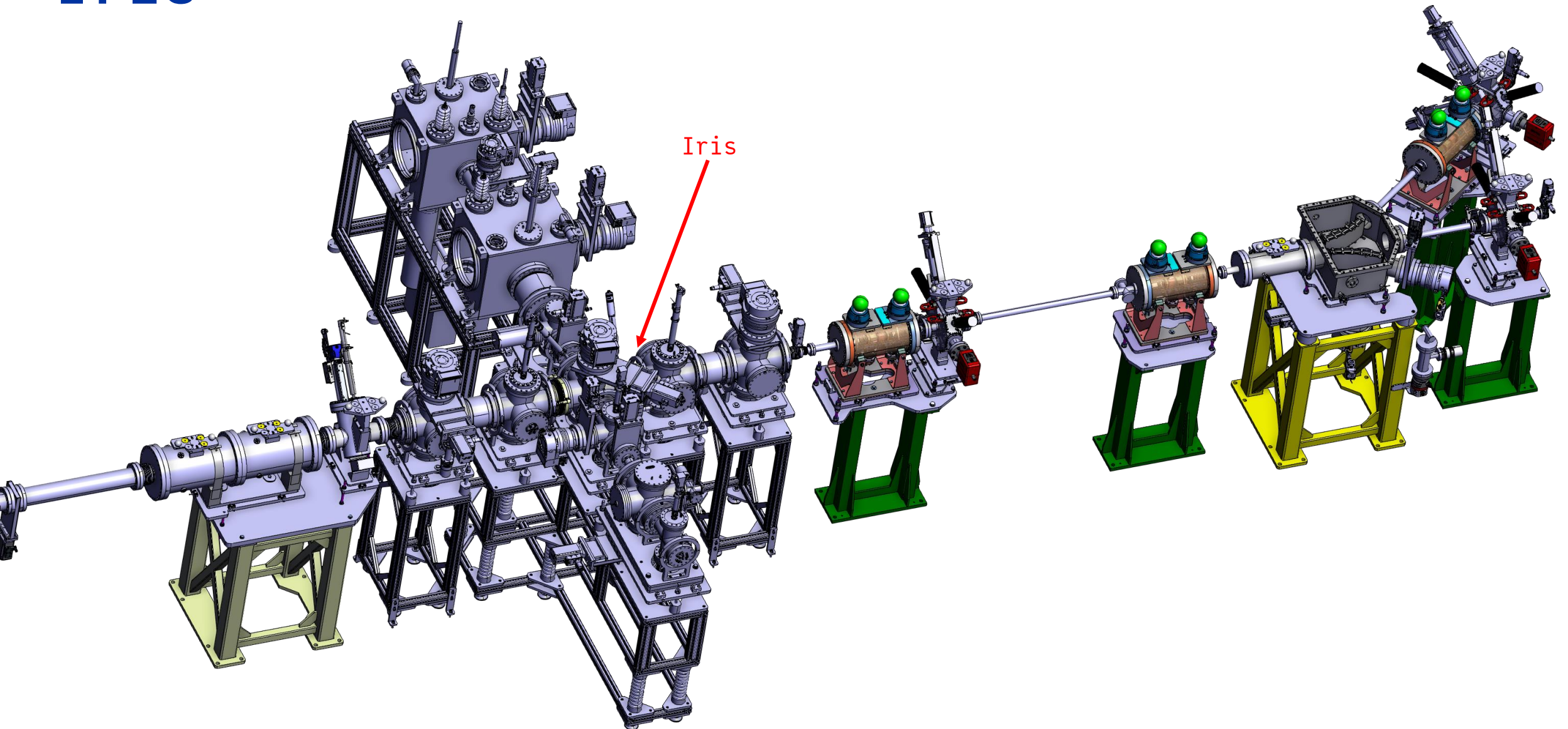

He propagation 20 mm orifice

- SP 2V => Injection $\approx 0.1 \text{ mbar}\times\text{l/s}$
- Simulation in two steps to overcome the lack of statistics (MC simulation)
- 2xStarCell 300 as in PUMA at ELENA
- No pumping from the trap
- $P \approx 10^{-10} \text{ mbar}$ next to the trap

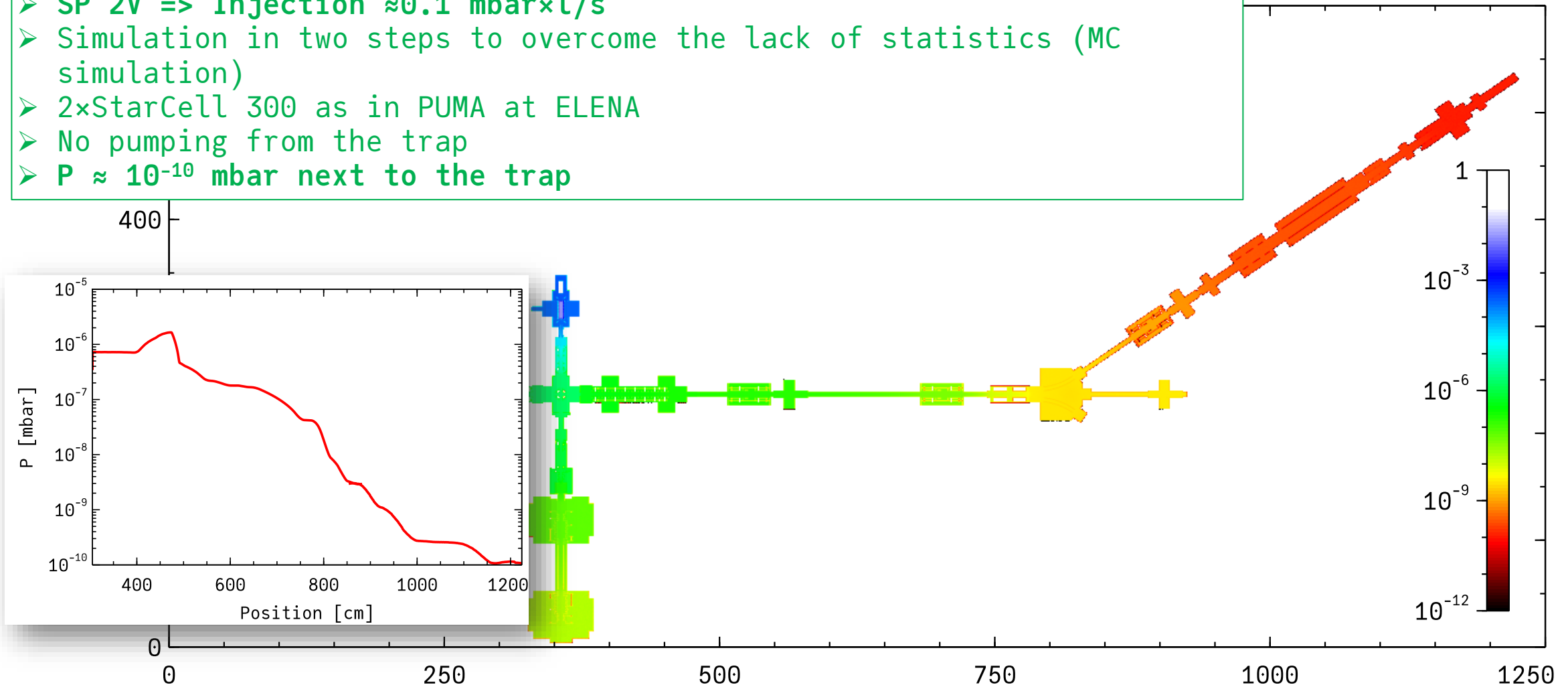

He propagation 20 mm orifice

- SP 2V => Injection ≈ 0.1 mbar \times l/s
- Simulation in two steps to overcome the lack of statistics (MC simulation)
- 2 \times StarCell 300 as in PUMA at ELENA
- No pumping from the trap
- $P \approx 10^{-10}$ mbar next to the trap

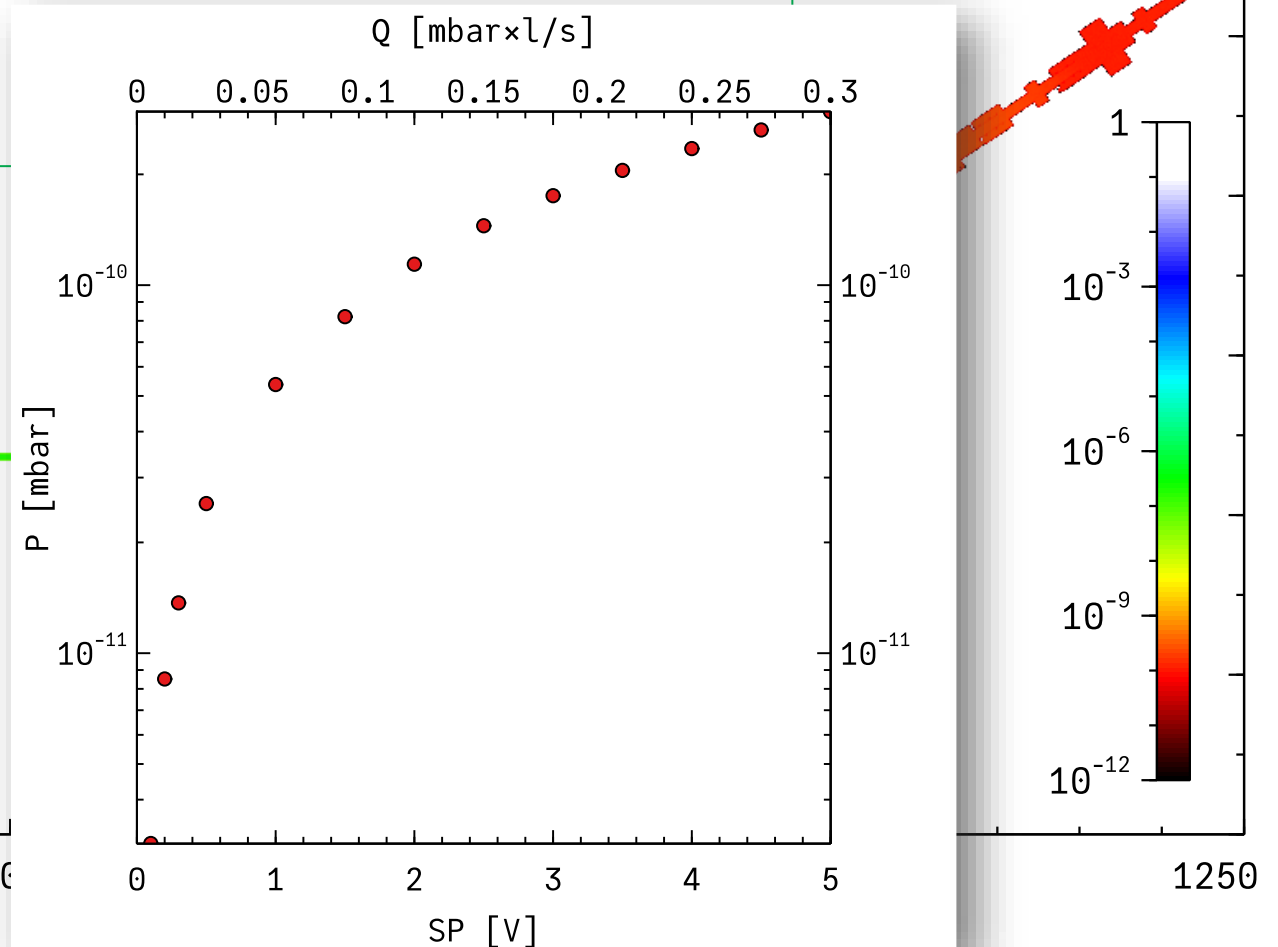
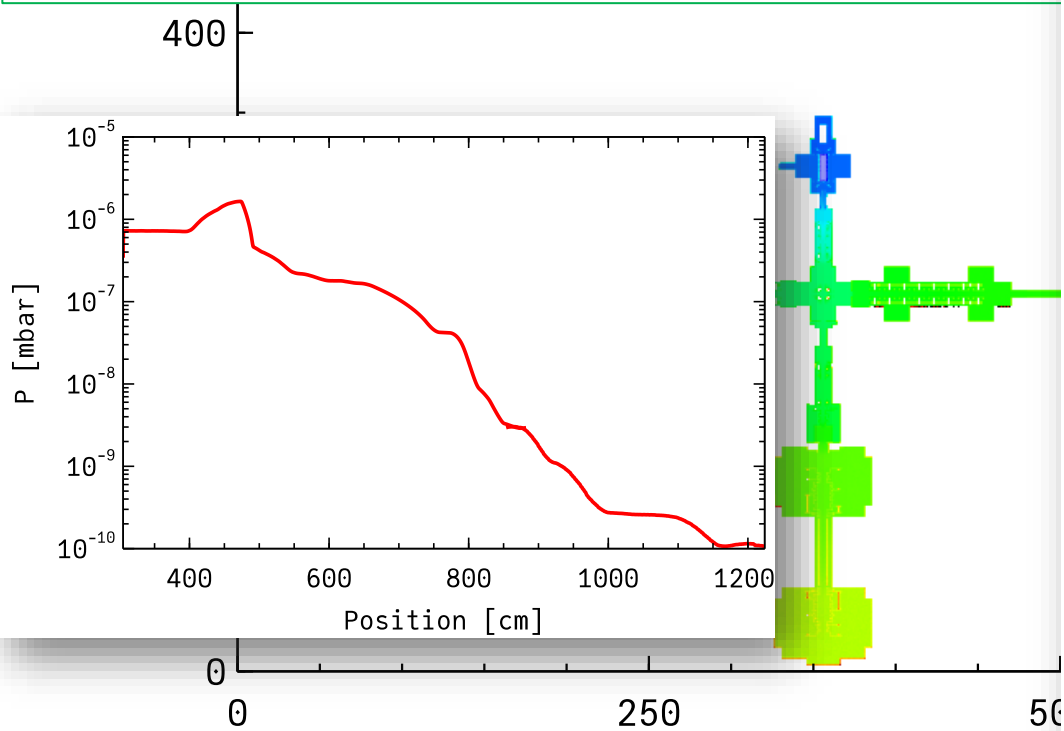

He propagation 4 mm orifice

- SP 2V => Injection $\approx 0.1 \text{ mbar}\cdot\text{l/s}$
- Simulation in two steps to overcome the lack of statistics (MC simulation)
- 2xStarCell 300 as in PUMA at ELENA
- No pumping from the trap
- $P < 10^{-11} \text{ mbar}$ next to the trap

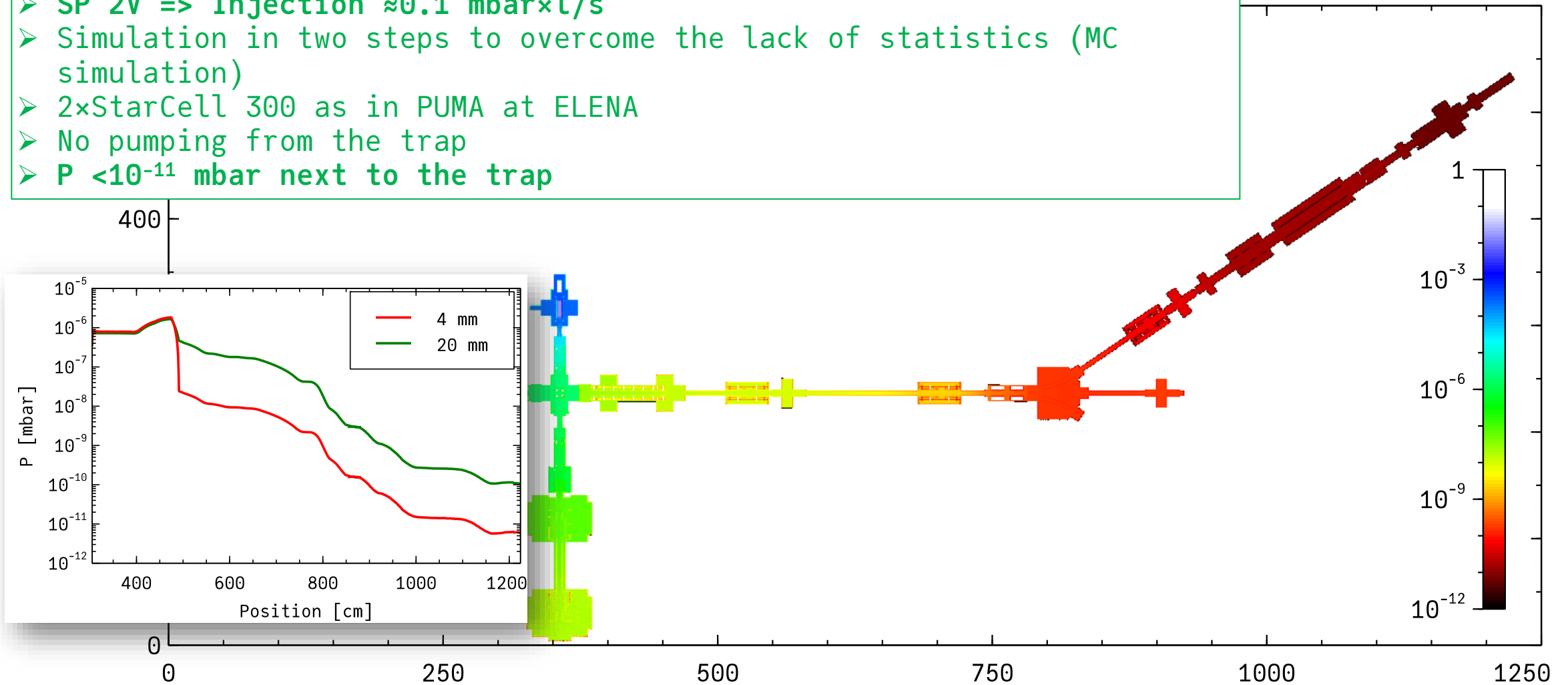

More iris

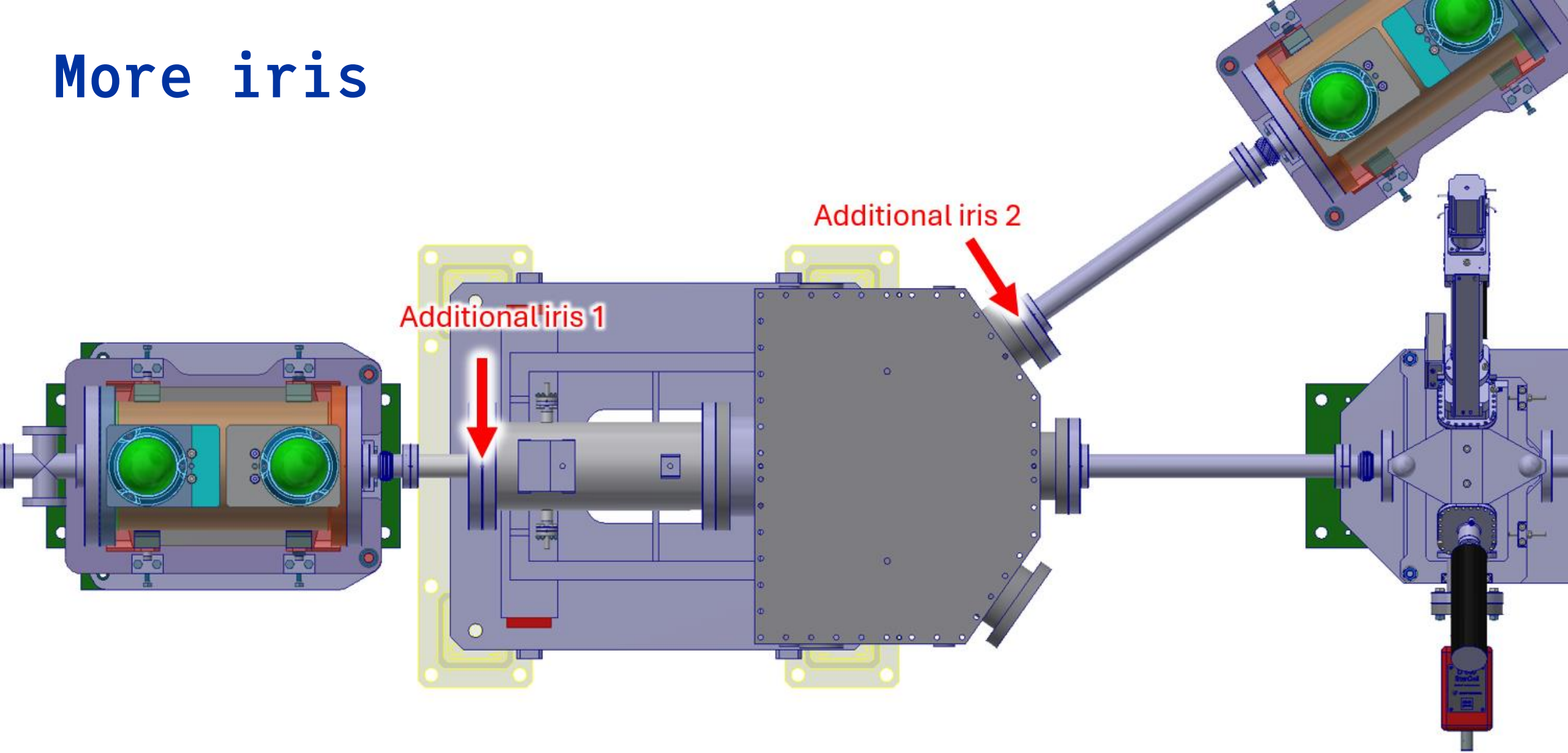

Courtesy P. Arrutia

Problem setup

- I ignore iris1, since beam size there will heavily depend on einzel+MR-TOF.
- Trying to understand reasonable openings for iris2 and iris3.
- Incoming beam taken from shoot-through config, but reduced remittances to $\text{emit}_x = \text{emit}_y = 1 \text{ mm.mrad}$ (RMS).

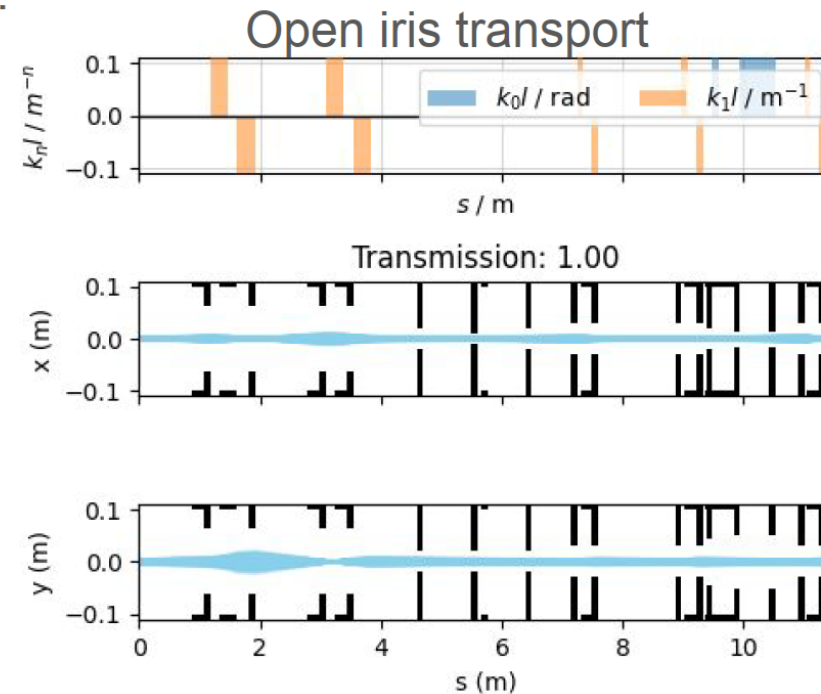
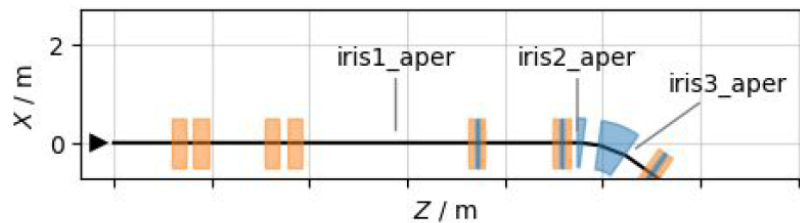
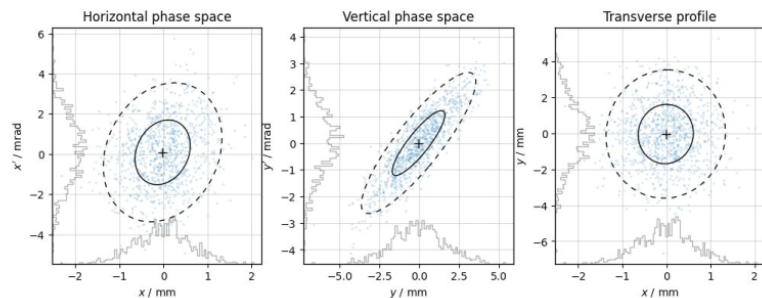

Courtesy P. Arrutia

Results

- Assuming circular irises, the optimiser finds below the relationship between beam loss and iris radius.
- Irises of ~3-4 mm in radius seem like a good choice for bunched beam.

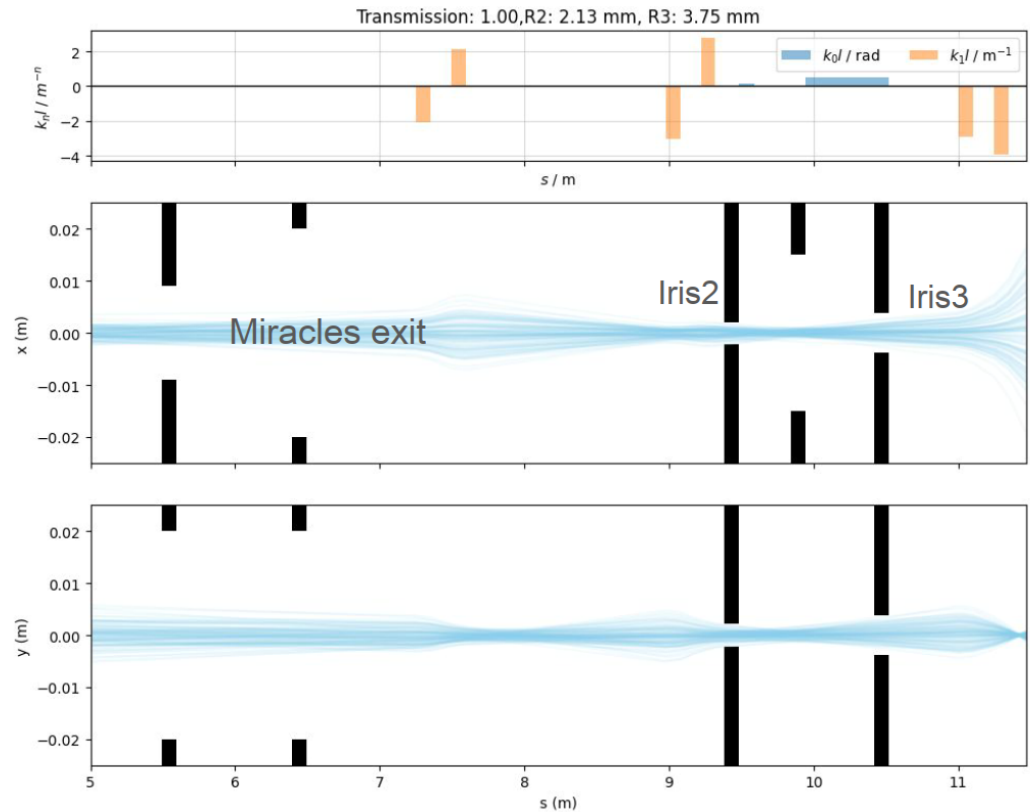
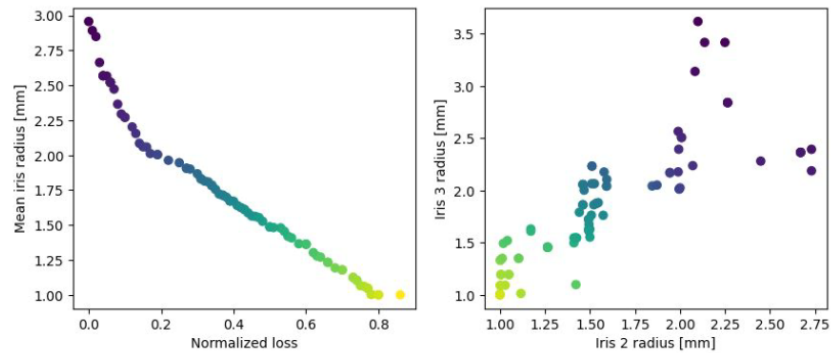

He propagation 3×4 mm orifices

- SP 2V => Injection $\approx 0.1 \text{ mbar}\cdot\text{l/s}$
- Simulation in 4 steps to overcome the lack of statistics (MC simulation)
- 2×StarCell 300 as in PUMA at ELENA
- No pumping from the trap
- $P < 10^{-12} \text{ mbar}$ next to the trap!

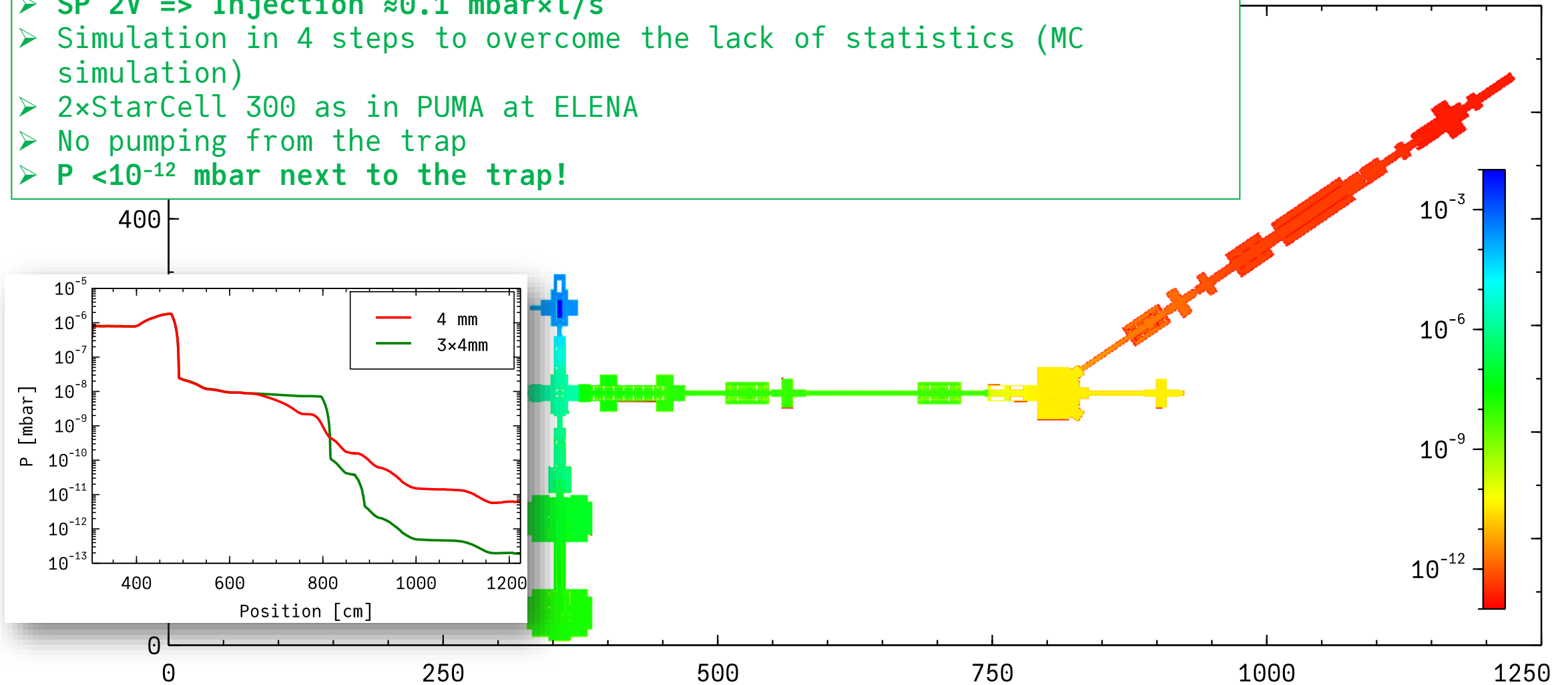

PUMA offline ion source

(Moritz Schlaich)

As a reminder, we do have one iris shutter in between each section and during the measurements I had them at a diameter (ISA 1) = 4.5 mm and a diameter (ISA 2) = 7.5 mm. Compare the figure of our ion source setup for the locations of both irises.

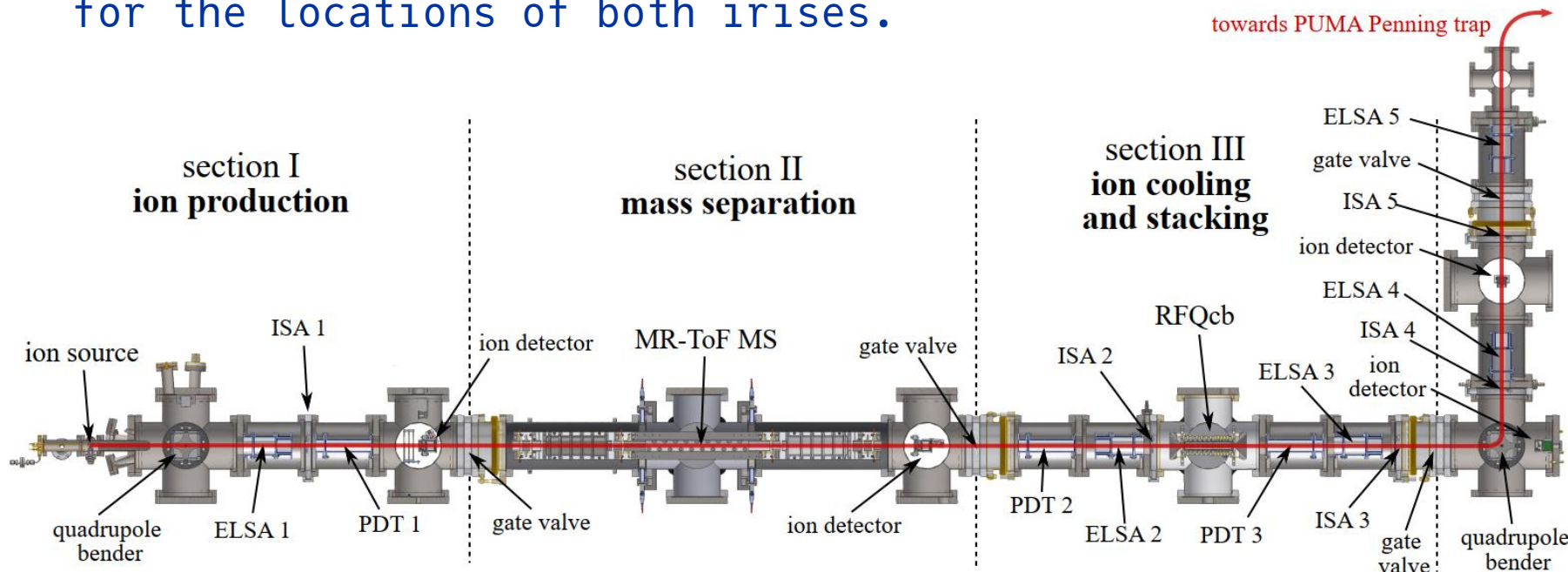
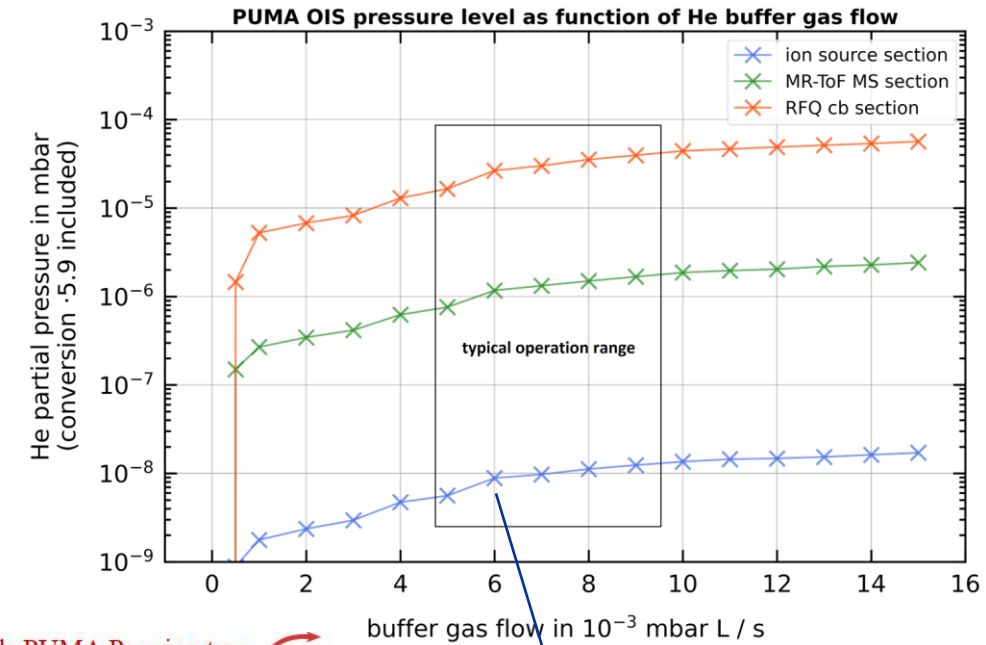

1000 times higher than requirement

H₂ propagation

- 10^{-8} mbar at entrance of the previous sector
- Assuming NEG coating in the first drift towards PUMA and in most of PUMA elements (0.005 sticking factor)
- 2xStarCell 300 as in PUMA at ELENA
- Outgassing pessimistic assumption 5×10^{-12} mbar \times l/s/cm²
- Effect of irises conductance restriction not considered
- Not considered pumping from the trap, neither NEG cartridges.
- $P \sim 10^{-11}$ mbar next to the trap

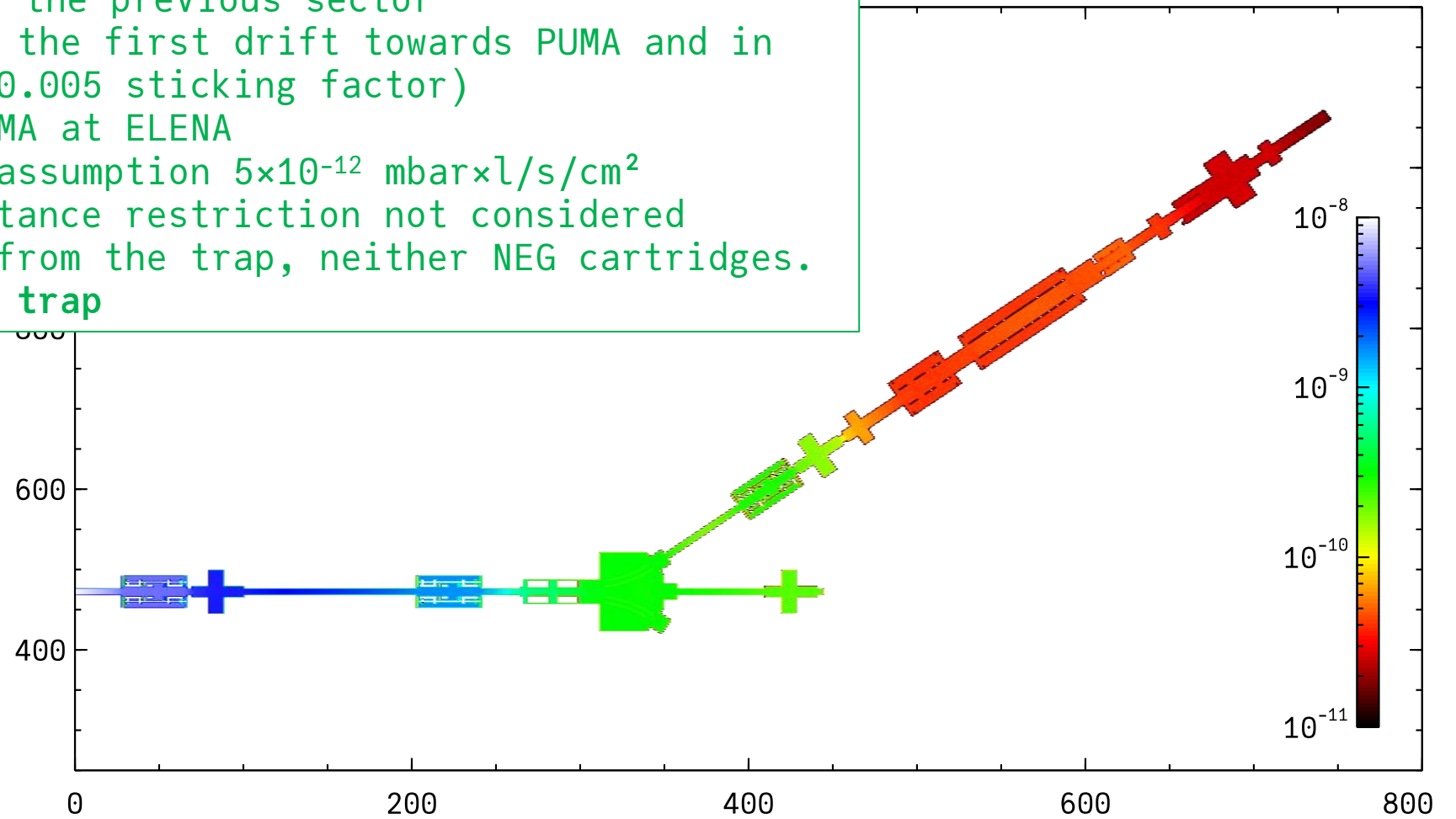

Equipment and budget

- Order TMPs, primary pumps and instrumentation?
- Sector valves to order as soon as layout is frozen
- All metal or series 10 V: valve at the interface experimental lines
- Hardware estimated to be higher than in the budget

Item	Q	CHF/piece	Total
Series 10 DN100CF	7	4	28
Series 10 DN40CF	1	4	4
HiPace 700	7	7	49
Series 10 DN150CF	7	5	35
Angle valve DN100	18	0.5	9
Hipace 300	3	6	18
Aluminum	6	0.5	3
		1	10
	11	1.5	31.5
	5	4	20
	7	1	7
	4	2	8
Series 48 DN40CF	2	15	30
NexTorr 500 -StarCell	3	9	27
TOTAL			279.5

Old slide

PUMA at ISOLDE			
Item	Model	units	kCHF/unit
Sector Valves	Viton sealed DN100	4	7.5
	All metal DN100	2	15
VPIs	to be defined	3	5.0
	VGP/VGR	3	2.50
TMPs	HiPace 300	3	6.00
	HiPace 700	3	7.00
VVRs	Viton sealed DN100	6	4.00
	Viton sealed DN150	3	5.00
Valves for VPGs	Angle valve	18	0.50
	Viton sealed DN100	9	1.00
Pirani	Pressure gauges	9	4.00
	Pressure gauges	9	1.50
Vacuum chambers	Production	5	5.00
	Cleaning coating and vacuum firing	5	3.00
Bolts seals, chains, etc.	Bolts seals, chains, etc.	200	0.10
SubTOTAL			307 kCHF
Control			83 kCHF
Total			390 kCHF

First evaluation sent 2023

Equipment and budget

- Pompes (turbos, primaries, NexTorr) + valves + instrumentation) : EDHs done -> 168kCHF
- Small Std components (vacuum connexions, compressed air...) : EDHs done -> 16kCHF
- The chambers are in production (~ 40kCHF (i.e. less than expected)) ready by end of 2023
- + ~83kCHF installation services not included)
- Total = ~310kCHF

Item:	Ref:	Needed qty:	Cost/item (CHF):	Total cost (CHF):	Qty at	Comments:
HiPace700-H-DN150CF	Onboard-elec	0	10250	0	0	0 replaced by sdt + booster pump
HiPace300-H-DN100CF	Onboard-elec	0	6070	0	0	0 replaced by sdt + booster pump
HiPace 80 DN63CF	tcp 350 + box	1	4112	4112	1	1 EDH 10573342
HiPace700 DN150CF	Onboard elec	1	5970	5970	1	1 EDH 10742652
HiPace700 DN150CF	Onboard elec	2			2	2 pumps for HV sectors
HiPace700 DN150CF	tcp 350 + box 250m	5			5	EDH 10573342
HiPace 300 DN100CF	Onboard elec	1			1	1 pump for HV sector / 1 pump for spare
HiPace 300 DN100CF	tcp 350 + box 250m	2			2	2 EDH 10573342
VVR CF150 for PG	Serie 10 10844-CE44 (24V)	7			7	7 EDH 10828746
VVR CF40 sector	Serie 01 - 01032-CE44 (24V)	1			1	1 EDH 10828746
VVR CF40 sector	Serie 48 - 48132-CE44-A	1			1	
VVR CF100 for PG	Serie 10 10840-CE44-00	1			1	
VVR CF100 sector	Serie 10 10840-CE44-00	1			1	
Turbo venting valve	PM Z01 200	1			1	
Pneumatic angle valve DN25KF	18.60.80.225.0	1			1	
N2 venting valve	18.20.20.620.1	1			1	
Penning		1			1	
Pirani digitales		1			1	
Controllers + cables for penning		1			1	
Secuvac		1			1	
Primary pump		1			1	
Scroll pump		1			1	
Transition between end RC610 and sector valve	ISLVCD_0021	1			1	2 Transitions vannes - pumping groups: ordered by Lukas
1st bellow after the sector valve	ISLVCD_0014	1			1	1 Already available (Lukas)
Chamber before the 1st quad RC620 (env 142mm)	ISLVCD_0015	1			1	1 lenght: 174mm on the drawing
Transition flanges of the 1st quad RC620	ST1962381	2			2	2 CF Zero Length Reducer Flanges 303402 VACOM
Bellow between the 1st quad RC620 and 1st diag. box	ISLVCD_0016	1			1	
Transition Nextorr for the 3 D Boxes	ISLDBEG0002	6			6	6 (+3 for Guillermo)
Bellow after the 1st D box	ISLVCD_0016	1			1	
Tube after the 1st D box 805mm	ISLVCD_0017	1			1	
Cross before the 2nd quad RC620	ST0465801	1			1	1 https://www.vacom.net/en/x40rs-316lms.html
Transition flanges of the 2nd quad RC620	ST1962381	2			2	2 CF Zero Length Reducer Flanges 303402 VACOM
Bellows after the 2nd quad RC620	ISLVCD_0014	1			1	
Transition after the 2nd quad RC620	ISLVCD_0021	1			1	
Kicker	ISLZKHA0001	1			1	
Tank SwithYard	ST1683144	1			1	1 Already existing
Transition after the SwitchYard to the 2nd DB	STDVFUHV0181	1			1	1 CF Zero Length Reducer Flanges 303375 VACOM
Tube to the 2nd DB	ISLVCD_0018	1			1	
Bellow before the 2nd DB	ISLVCD_0016	1			1	
Transition after the 2nd DB	ISLVCD_0019	1			1	
Transition after the SwitchYard to the 3rd quad RC620	STDVFUHV0181	1			1	1 CF Zero Length Reducer Flanges 303375 VACOM
Tube between the Swityard and the 3rd quad RC620	ISLVCD_0018	1			1	
Bellow before the 3rd quad RC620	ISLVCD_0014	1			1	
Transitions flanges of the 3rd quad RC620	ST1962381	2			2	2 CF Zero Length Reducer Flanges 303402 VACOM
Bellow before the 3rd DB	ISLVCD_0016	1			1	
Transition after the 3rd DB	ISLVCD_0019	1			1	
Transition to the HiPace 700 SY	ISLVCD_0022	1			1	

Old slide

Equipment and budget

- Pumps (turbos, primaries, NexTorr) + valves + instrumentation) – 168kCHF: **received**
- Small Std components (vacuum connections, compressed air...) – 16kCHF: **received, CF gaskets are late**
- The chambers are in production (~ 40kCHF than expected) **arrive middle**
- + ~83kCHF (cables installation, back services not included)
- **Total = ~310kCHF**

Item:	Ref:	Needed qty:	Cost/item (€)	Cost (€)	Comments:
HiPace700 H-DN150CF	Onboard-elec	0			0 replaced by sdt + booster pump
HiPace300 H-DN100CF	Onboard-elec	0			0 replaced by sdt + booster pump
HiPace 80 DN63CF	tcp 350 + box				1 EDH 10573342 / 19-S-017
HiPace700 DN150CF	Onboard elec				1 EDH 10742652 / 19-S-017 2 pumps for HV sector
HiPace700 DN150CF	tcp 350 + box 250m				5 EDH 10573342 / 19-S-017
HiPace 300 DN100CF	Onboard elec				0 1 pump for HV sector / 1 pump for spare
HiPace 300 DN100CF	tcp 350 + box 250m	2			2 EDH 10573342 / 19-S-017
VVR CF150 for PG	Serie 10 10844-CF				7 EDH 10828746 --> 169-R-022
VVR CF40 sector	Serie 01 - 01				1 EDH 10828746 19-S-017
VVR CF40 sector	Serie	0		2	0 Tests done in lab 101
VVR CF100 for PG		0		3	0 solenoids to be replaced by 24V ! / 19-S-017
VVR CF100 sector		10	12000		3 EDH 10828746 --> 119-S-017
Turbo venting valve		495	3465		7 EDH 10573342 / 19-S-017
Pneumatic angle valve DN20		421	7578		18 EDH 10649321 / 169-R-12 K.3.3
N2 venting valve		4	600	2400	4 EDH 10649321 / 169-R-12 K.3.3
Penning		8	970	7760	8 EDH 10649321 / 169-R-12 K.3.3
Pirani di		8	1190	9520	8 We have enough in 169 storage Abel is taking care of it
		5	1528	7640	5 Do we need it?
		3	4000	12000	3 EDH 10700439 / 169-R-012
		2			0 Already there (Lukas)
		2	400	800	2
	code 10351	10	100	1000	10 EDH 10880658 / 169-R-12 K.3.3 EDH 10880658 / 169-R-12 K.3.3
	Nextorr D500 Starcell C4 SAES	3	8870	26610	3 EDH 10673289 / 19-S-017 C4 portable + cables already there Abel is taking care of it
	Agilent				3 EDH 10828746 / 19-S-017
		3	200	600	3 EDH 10828746 / 19-S-017
	Valves ISO 25KF	6	212	1272	6 EDH 10674470 / 169-R-12 K.3.3
	Pirani TPR280	16	228	3648	16 EDH 10649321 / 169-R-12 K.3.3
Screws	Screws, nuts, washes, studs etc...				EDH 10880825 / 19-R-033
Gaskets					EDH 10880825 / partially received 169-R 14.4.3
Pumping groups connexions	ISOKF transitions, gaskets, clamps etc...				waiting for quotation and EDH 10881483 169-R-12 K.3.3
Vacuum chambers / transitions CF		35			35 On going with JMM for the chambers / EDH 10841306 169-R-12 J.4.3 for the transitions
Full range controller + cable					Abel is taking care of it
Full range for Booster pump	18.20.50.014.2	1	1013	1013	1 EDH 10649321 / 169-R-12 K.3.3

Old slide

Equipment and budget

Components:	Cost (kCHF):	Status:	Comment:
Pumps + instrumentation:	168	Ready for installation	
Vacuum chambers:	40	Ready for installation	ISLVCD—0024 is waiting for NEG coating
Control:	83	Ready	
Other vacuum components:	16	Ready for installation	
TOTAL:	307		

Vacuum acceptance tests

Legend:
 Acceptance test to be done
 Acceptance test done → OK for inst.
 Acceptance test done → Inst. tolerated
 Acceptance test done → NOK for inst.

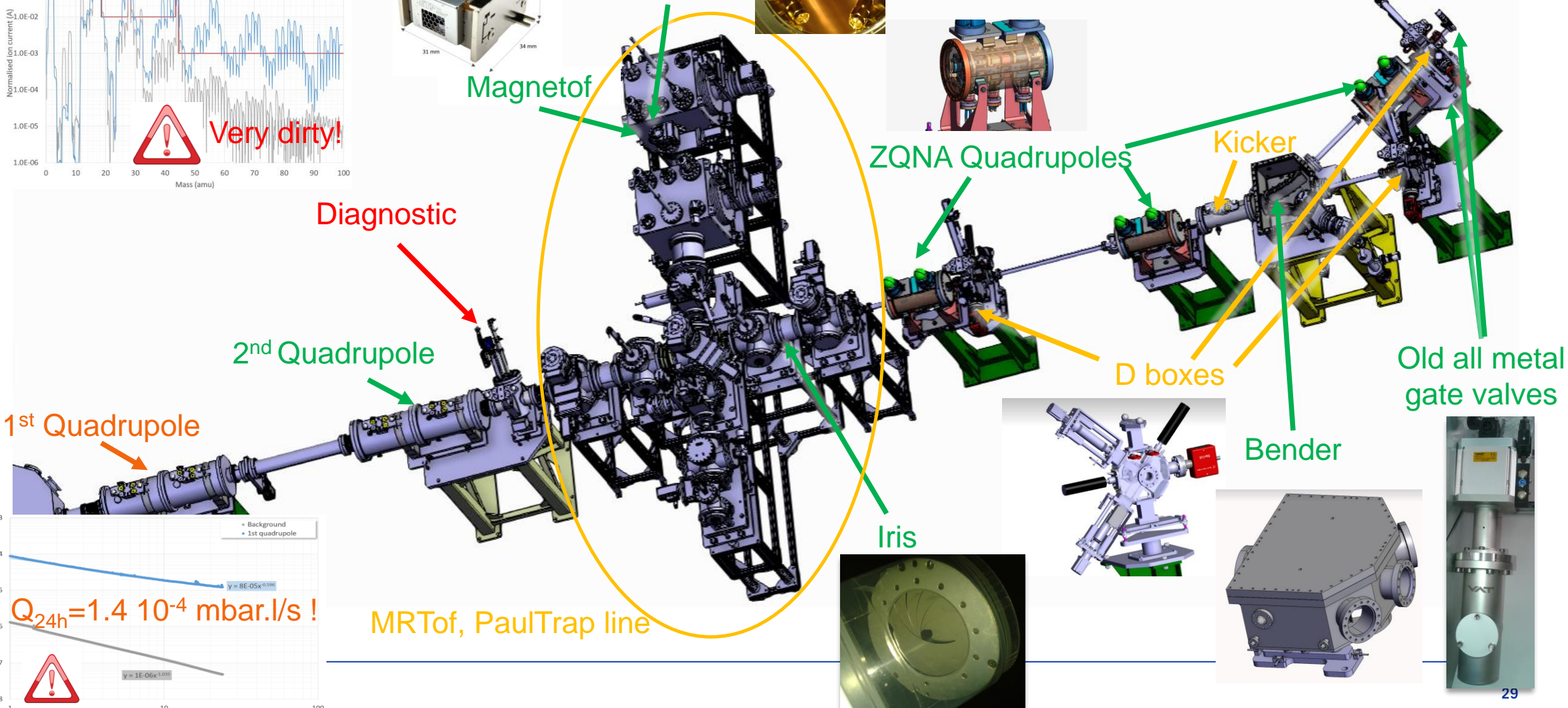
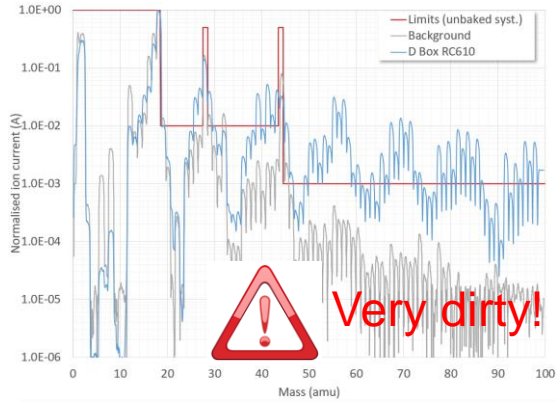

What do we have and what do we need?

What we have:

- Vacuum layout is 100% defined.
- Vacuum devices are ready to be installed.
- TE/VSC/ICM can not do more at this stage.
- Main risk => He propagation. With estimated flow there is no margin. One iris achieves a 17 times reduction => Second iris? => 2 extra solve the issue, but not integrated at this stage!
- Reasonable H₂ pumping speed => H₂ pressure in front of the trap will be determined by the outgassing sources and pumping speed in its vicinity.
- ~~TMPs H version for maximum compression ratio (50 times higher for H₂ and 30 for He) => Too expensive => Booster TMP for last 2 turbos~~
- PUMA offline ion source => He propagation may be an issue => Deserves a detailed study => Rough estimate 10⁻¹⁰ mbar range.
- The two primary pumps for the high voltage parts will work at high voltage.

What we need:

- Waiting for NEG coating on one chamber but the machine can also be operational without.
- Installation planning => **beginning of 2026? Please note that if the installation does not happen before the start of LHC LS3 we cannot commit to do it in 2026 !**

Thank you