

1. PROJECT CODE ALICE		ALICE TASK DESCRIPTION		
2. EDMS ID. XXXXXXXX		3. TASK NO. FIT200915_002		4. PAGE 1 OF 15
5. DISCREPANCY REPORT SHEET(S) NUMBER(S)				
6. CATEGORY DETECTOR		7. PART NAME FAST INTERACTION TRIGGER (FIT)		8. SERIAL NUMBER
9. APPLICABLE DOCUMENTS				
10. TASK TITLE FIT-A Deinstallation				
11. OPER SEQ. NO.	12. OPERATIONS (Print, Type, or Write Legibly)			13. NOTE QA/PE
	<u>SCOPE</u>			
	<p>Two Fast Interaction Trigger (FIT) are installed at either side of the IP in ALICE to be able to benefit from the improved performance of the LHC. The one on the A side consists of a timing detector (T0A+) attached to a large scintillator ring (V0+). Made from two quasi-symmetrical halves, each one consisting of a V0A and a T0A module, they rest on a mechanical sliding system that allows removing and installing them in their nominal position. The purpose of the present document is to provide information and guidelines for the deinstallation of the FIT-A detector during LS3.</p> <p style="text-align: center;"><u>WARNING</u></p> <p style="text-align: center;">This procedure requires working in a radiation supervised area, lifting operation and working at height. All Safety regulation and procedures must be followed</p> <p style="text-align: center;">This procedure requires exposure of the beryllium beam pipe. Only authorized personnel shall be involved.</p> <p style="text-align: center;">Fence the miniframe around the working area to limit the access only to personnel involved in the intervention.</p> <p style="text-align: center;">Suspend any other activity in L3 and on the miniframe</p>			
14. ORIGINATOR		15. TASK PROJECT ENGINEER		
Massimo Angeletti				
16. ALICE PROJECT ENGINEER		17. QUALITY-SAFETY ENGINEER		
Corrado Gargiulo		Elisa Laudi and Klaus Barth		
18. ALICE INTEGRATION		19. ALICE TECHNICAL COORDINATOR		
XXXXXXXX		Arturo Tauro		
20. TASK CLOSED ACCEPTANCE SIGNATURE				21. DATE
APPROVAL (Printed or Typed and Signed)				

ALICE TASK SHEET
CONTINUATION PAGE

3. TASK SHEET NO

FIT200915_002

5. DISCREPANCY NO.

11. OPER
SEQ. NO.

12. OPERATIONS
(Print, Type, or Write Legibly)

13. NOTE QA/PWE

Assembly drawings	CDD number/ ST
FT0-A_FV0-A-FOR INSERTION	ALIP2A__1495

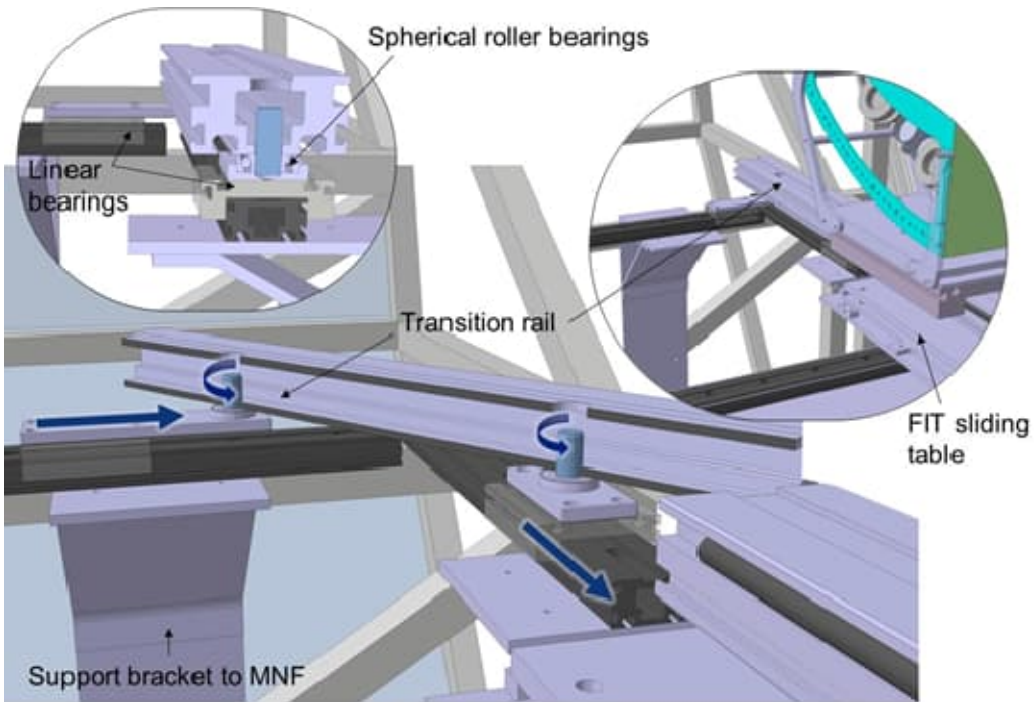
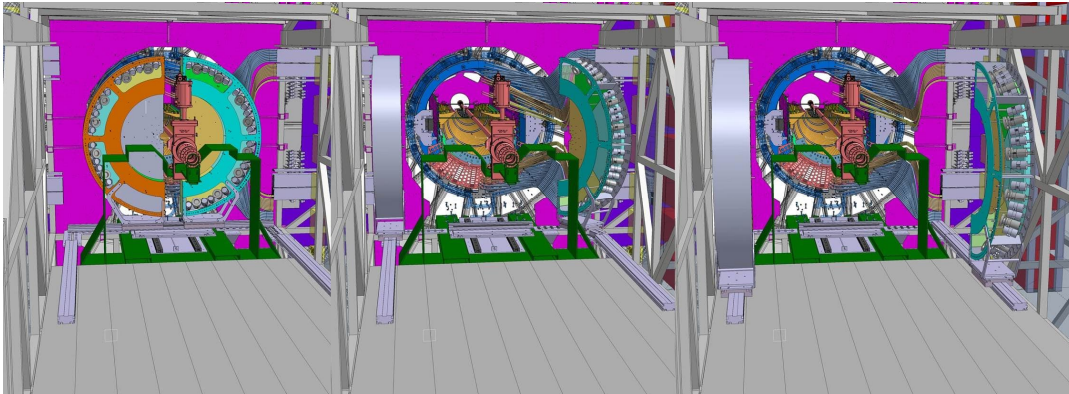

1. Open this Task Sheet.

ALICE TASK SHEET
CONTINUATION PAGE

3. TASK SHEET NO

FIT200915_002

5. DISCREPANCY NO.

11. OPER
SEQ. NO.12. OPERATIONS
(Print, Type, or Write Legibly)

13. NOTE QA/PWE

2. Preparation

- 2.1 Obtain authorization from ALICE Technical Coordination to start the task.
- 2.2 Verify that the following deinstallation tasks are completed:
- Open PX24 plug
 - Deinstallation UX25 shielding
 - BCM removal
- 2.3 Verify that Survey of the FIT has been performed.
- 2.4 Verify readiness of the assembly tools from document : {EXCEL summary}

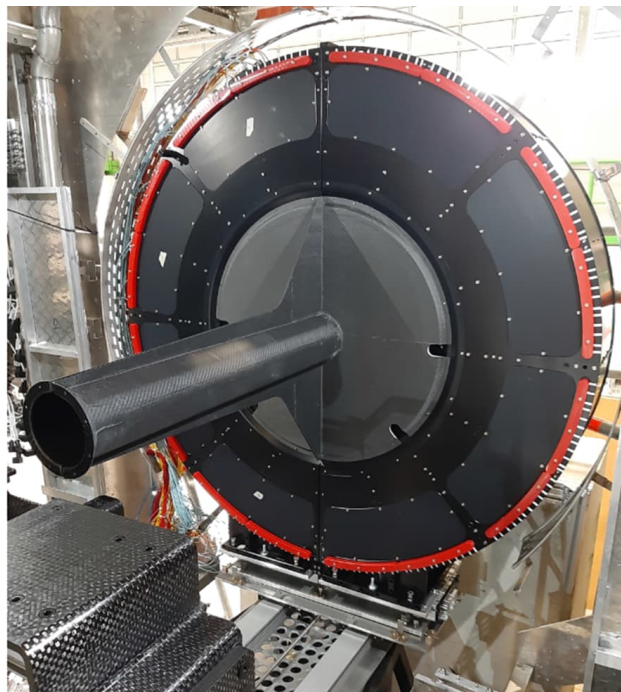
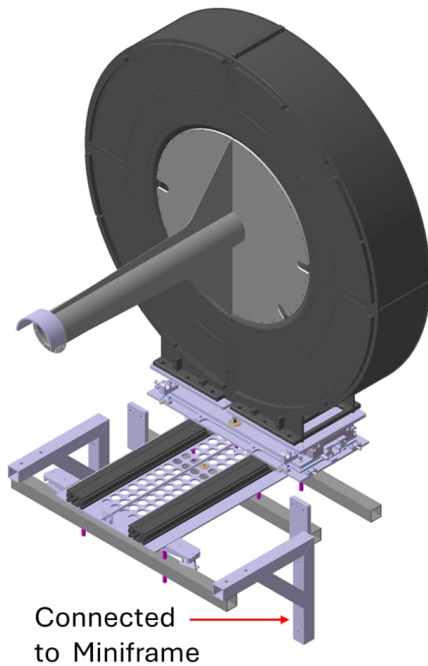

3. FIT-A: removal

- 3.1 Ensure that all fibers and cables from both the FIT-A patch panels are disconnected and properly protected.
- 3.2 Ensure that the beam pipe is in a safe condition, preferably not under vacuum (filled with Neon). Verify that the beam pipe valve is closed and that the beam pipe valve support stiffeners (ALIITSUP0968) are installed.

ALICE TASK SHEET

CONTINUATION PAGE

3. TASK SHEET NO

FIT200915_002

5. DISCREPANCY NO.

11. OPER
SEQ. NO.12. OPERATIONS
(Print, Type, or Write Legibly)

13. NOTE QA/PWE



3.3 Remove the miniframe bridges (**STnumber**)

3.4 Install FIT rails and supports (FT0-A_FV0-A-FOR INSERTION ALIP2A__1495)

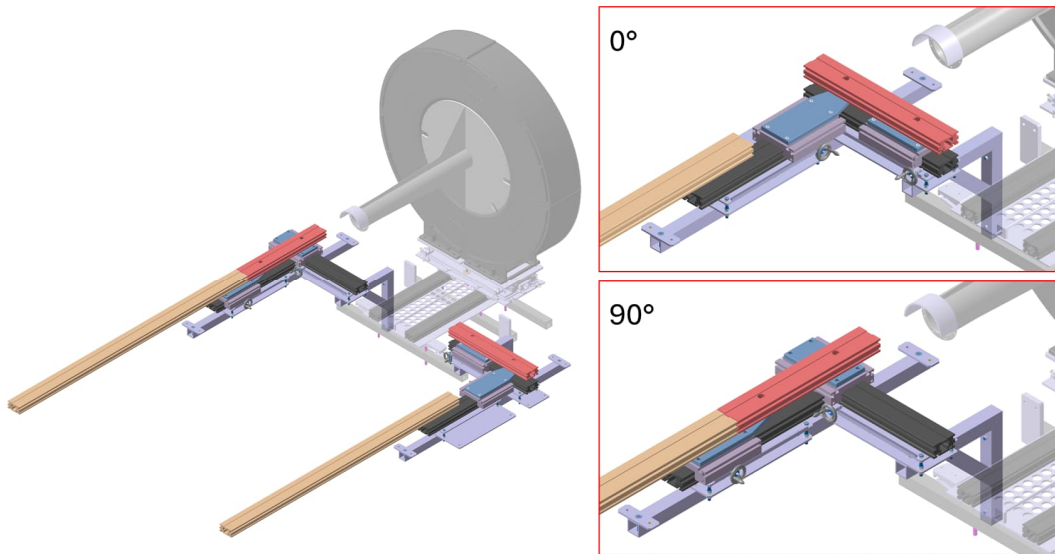

3.5 Measure the angle, position, and height of the rails and supports with respect to the BP, as required for reinstallation.

ALICE TASK SHEET
CONTINUATION PAGE

3. TASK SHEET NO

FIT200915_002

5. DISCREPANCY NO.

11. OPER
SEQ. NO.12. OPERATIONS
(Print, Type, or Write Legibly)

13. NOTE QA/PWE

3.6

Dismount beam pipe protections (ST1305212_01): CFRP covers and the Bosh support structures protecting the CFRP covers. Take some photos after removing the CFRP covers.

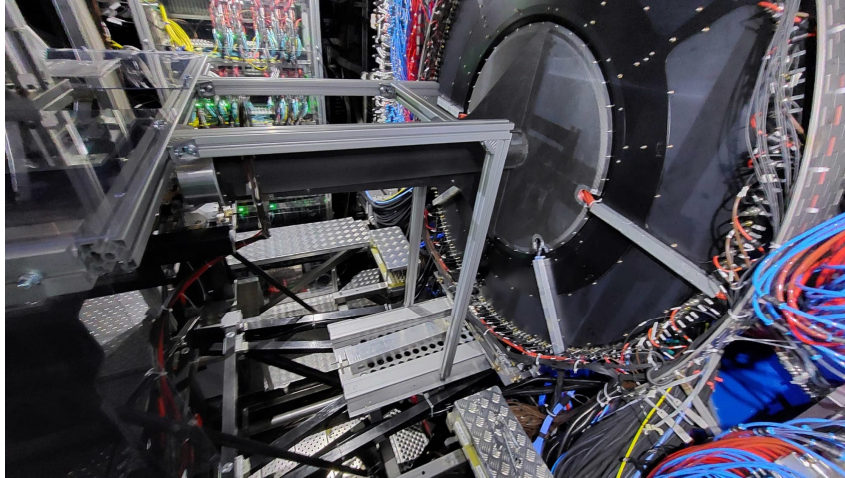

3.7

Remove the top rear support (Ref.1) attached to the miniframe above the FIT, and remove locking screws (Ref.2).

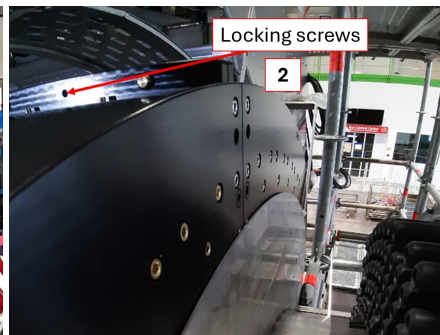
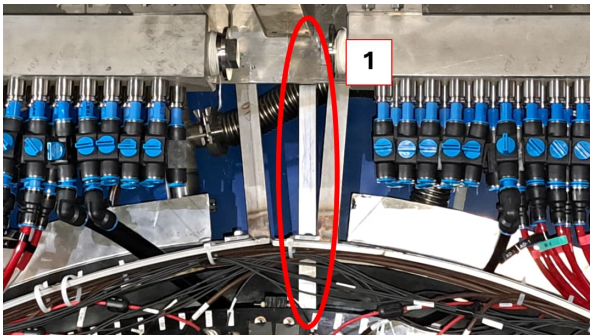

3.8

Move the FIT along the two rails of FIT adjusting table (ST0906224). Move the FIT back towards the miniframe by turning the bar (Ref.1). Use the 3 height adjustment screws per halves to compensate for the angular difference between

ALICE TASK SHEET
CONTINUATION PAGE

3. TASK SHEET NO

FIT200915_002

5. DISCREPANCY NO.

11. OPER
SEQ. NO.12. OPERATIONS
(Print, Type, or Write Legibly)

13. NOTE QA/PWE

the beam pipe and the FIT positioning system. Two Height adjustment screws are at the front of the FIT-A (Ref.2) while the third is at the rear. Check the top and bottom clearance (15mm nominally, Ref.3) during the movement and adjust if necessary.

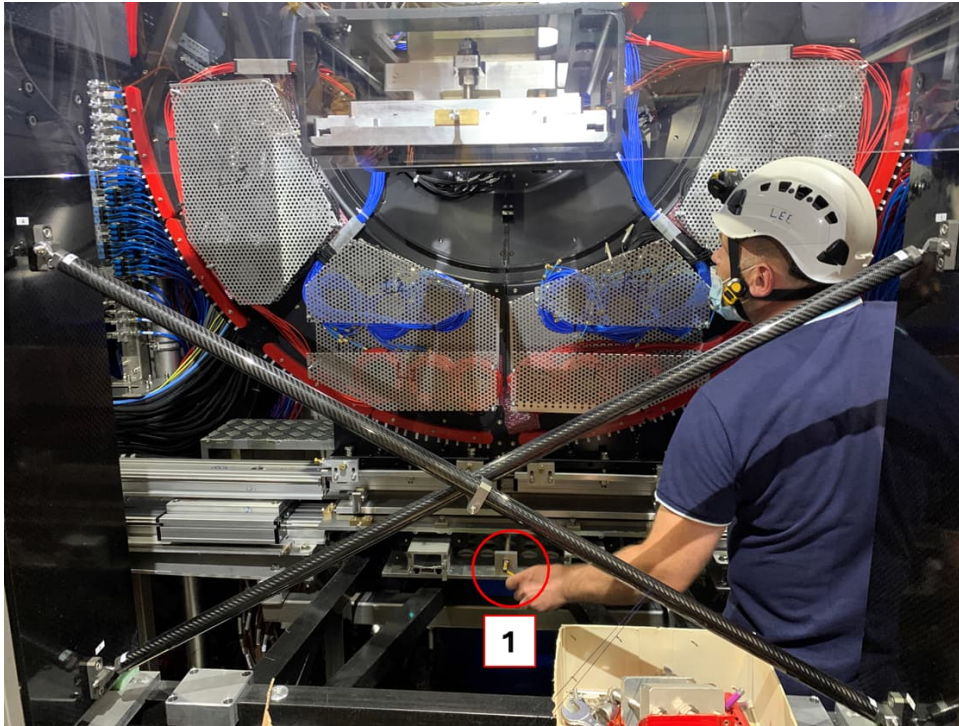

ALICE TASK SHEET
CONTINUATION PAGE

3. TASK SHEET NO

FIT200915_002

5. DISCREPANCY NO.

11. OPER
SEQ. NO.12. OPERATIONS
(Print, Type, or Write Legibly)

13. NOTE QA/PWE

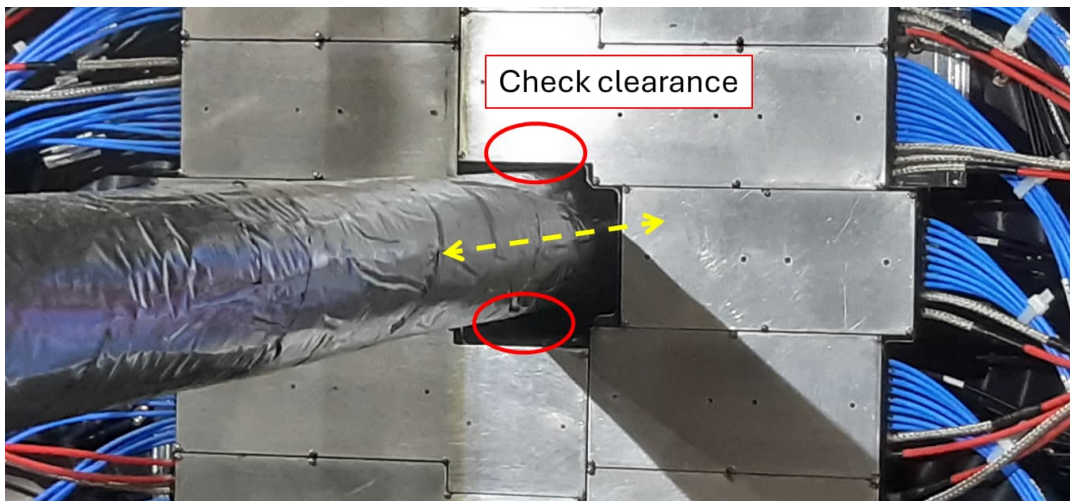
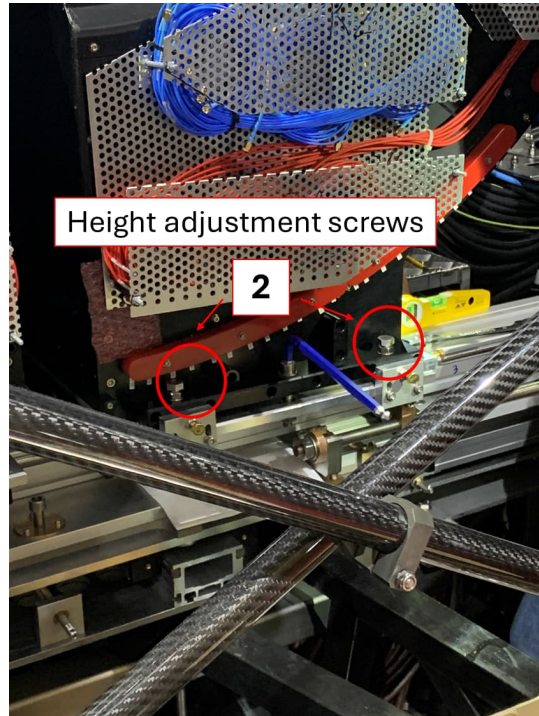

3.9

Open the two halves. Connect the bar mechanism of the FIT translation system (ALIP2A__1429) to the base plate (Ref.1). Rotate the two handwheels (Ref.2)

ALICE TASK SHEET
CONTINUATION PAGE

3. TASK SHEET NO

FIT200915_002

5. DISCREPANCY NO.

11. OPER
SEQ. NO.12. OPERATIONS
(Print, Type, or Write Legibly)

13. NOTE QA/PWE

until the FIT-A left and the FIT-A right are fully open.

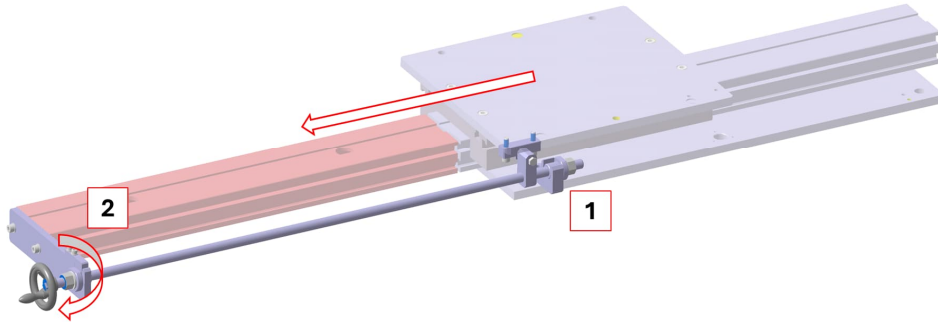

3.10 Install the two temporary BP protections (transparent +PVC tubes).

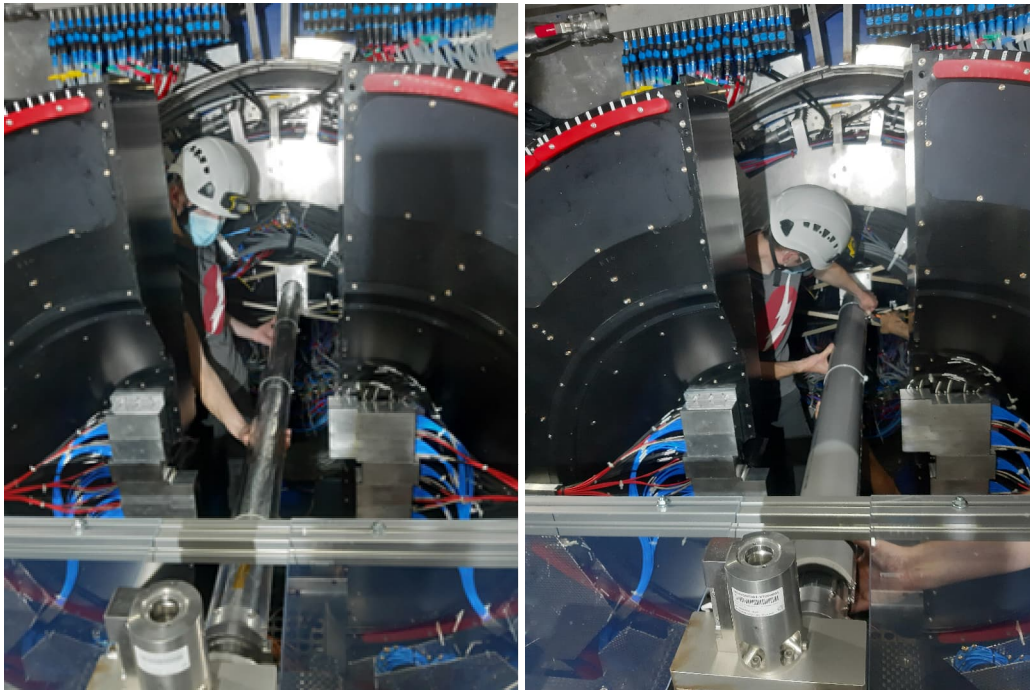

3.11 Remove the bar mechanism to the base plate.

ALICE TASK SHEET
CONTINUATION PAGE

3. TASK SHEET NO.

FIT200915_002

5. DISCREPANCY NO.

11. OPER
SEQ. NO.12. OPERATIONS
(Print, Type, or Write Legibly)

13. NOTE QA/PWE

3.12

Rotate the right and left halves of the FIT by 90 degrees using the handwheels that drive the pinion on the rack bar (pivoting rails, ALIITSUP0437).

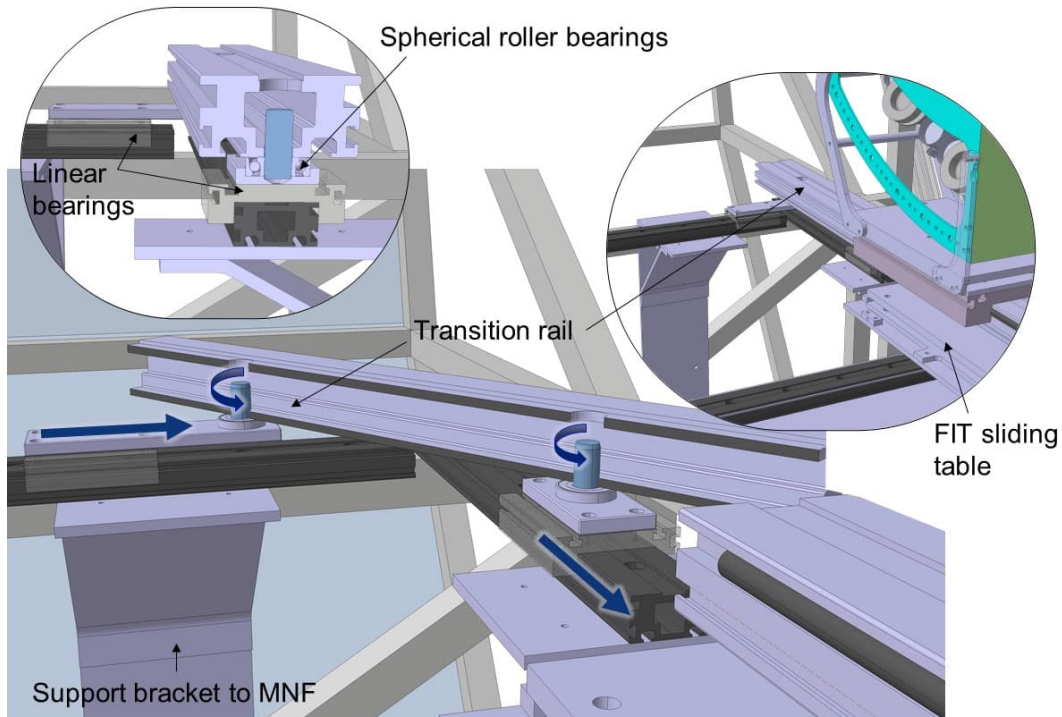

3.13

Move the two halves at the end of the lateral rails.

3.14

Install the lifting jig (spreader jig) on the two halves.

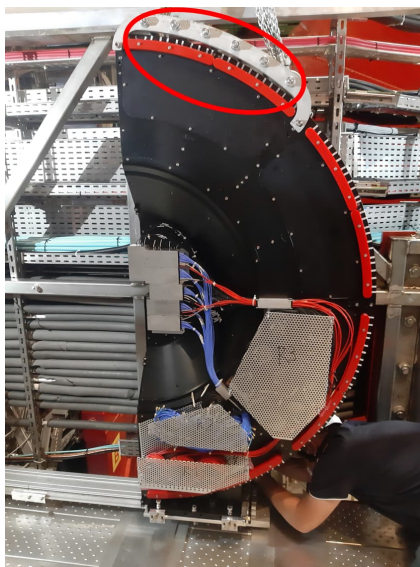

4.

FIT-A: Transfer to Low Beta Platform

ALICE TASK SHEET
CONTINUATION PAGE

3. TASK SHEET NO

FIT200915_002

5. DISCREPANCY NO.

11. OPER
SEQ. NO.12. OPERATIONS
(Print, Type, or Write Legibly)

13. NOTE QA/PWE

- 4.1 Contact ALICE Technical Coordination for authorization to move the FIT-A detector to the Low Beta Platform. Use the crane at minimum speed. Crane operations described in this procedure shall be performed by an operator trained and authorized for this specific procedure.
- 4.2 Ensure that the Low Beta Platform area is fenced and that the access is restricted to FIT-A deinstallation team.
- 4.3 Ensure that the transport support (bosh exoskeleton and feet) and the wood box are placed on the Low Beta Platform.
- 4.4 Connect the lifting jig (the spreader jig) of FIT-A left to the miniframe bridge crane.
- 4.5 Unlock the three locking screws per half at the FIT-A base and tension the chains of the miniframe bridge crane. Note that three lifting points are used, two of which are ratchet chain lever hoists to adjust the center of gravity.
- 4.6 Lift the FIT-A left with the miniframe bridge crane to the Low Beta Platform. The detector shall be lifted in the 0-degree orientation. Use the crane at minimum speed.

ALICE TASK SHEET

CONTINUATION PAGE

3. TASK SHEET NO

FIT200915_002

5. DISCREPANCY NO.

11. OPER
SEQ. NO.12. OPERATIONS
(Print, Type, or Write Legibly)

13. NOTE QA/PWE

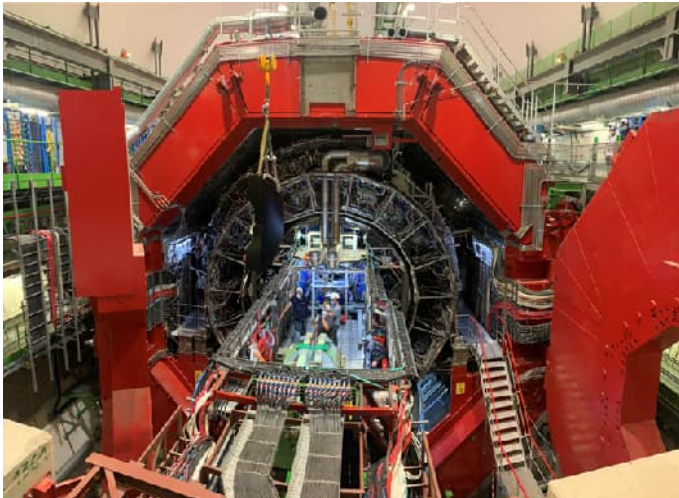

- 4.7 Lower the FIT-A left and secure it to its transport feet. Note that the three height adjustment screws used to align the FIT-A half angle must be removed beforehand.

ALICE TASK SHEET
CONTINUATION PAGE

3. TASK SHEET NO

FIT200915_002

5. DISCREPANCY NO.

11. OPER
SEQ. NO.

12. OPERATIONS
(Print, Type, or Write Legibly)

13. NOTE QA/PWE

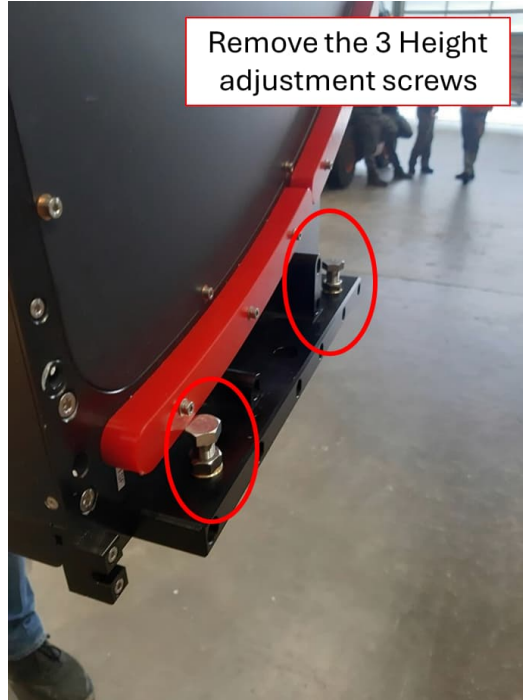

4.8 Install the bosh transport structure.

ALICE TASK SHEET

CONTINUATION PAGE

3. TASK SHEET NO

FIT200915_002

5. DISCREPANCY NO.

11. OPER
SEQ. NO.12. OPERATIONS
(Print, Type, or Write Legibly)

13. NOTE QA/PWE



4.9 Remove the lifting jig (the spreader jig) and relocate lifting lugs to the upper part of the frame. Note that four lifting points are needed with the two rear ones used as an additional safety measure.

4.10 Lower FIT-A onto its large face on the ground.



ALICE TASK SHEET

CONTINUATION PAGE

3. TASK SHEET NO

FIT200915_002

5. DISCREPANCY NO.

11. OPER
SEQ. NO.12. OPERATIONS
(Print, Type, or Write Legibly)

13. NOTE QA/PWE

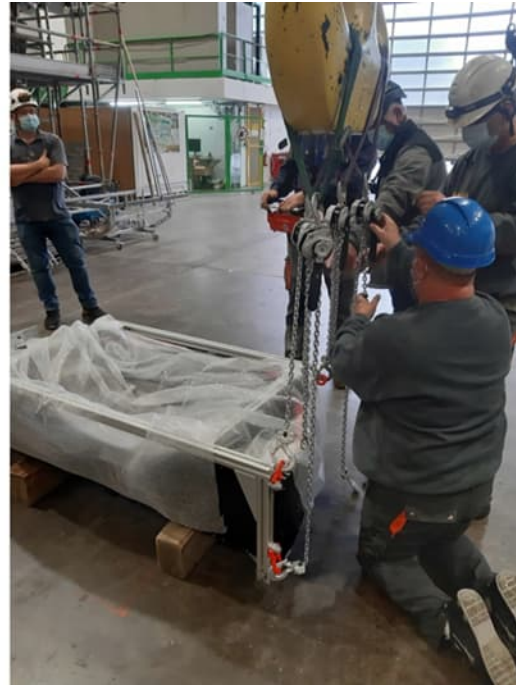

4.11 Disconnect the miniframe bridge crane and reconnect it at the four lifting lugs located at the extremities of the Bosh transport structure in order to lift the half in the horizontal position.

4.12 Lift the detector and place it inside the wooden box.



ALICE TASK SHEET
CONTINUATION PAGE

3. TASK SHEET NO

FIT200915_002

5. DISCREPANCY NO.

11. OPER
SEQ. NO.12. OPERATIONS
(Print, Type, or Write Legibly)

13. NOTE QA/PWE

4.13 Disconnect the miniframe bridge crane.

4.14 Close the wooden box.

5. FIT-A: Transfer to SX2 hall

5.1 Contact ALICE Technical Coordination for authorization to lift the FIT-A left to the SX2 hall. Use the crane at minimum speed. The cranes operations described in this procedure shall be performed by an operator trained and authorized for this specific procedure.

5.2 Ensure that the SX2 hall area is fenced and that the access is restricted to detector installation team.

5.3 Attach the P2 crane and the pallet truck (orange, shown in the picture below) to the wooden box.

5.4 Lift the half to the SX2 hall area. The box is to be lifted in the 0-degree orientation. Use the crane minimum speed.



5.5 Disconnect the P2 Crane

5.6 Repeat steps from 4.1 to 5.6 for the FIT-A right.

5.7 Remove FIT rails and supports (FIT translation system ALIP2A__1495)

5.8 Perform RP measurement on FIT-A left and right in SX2

5.9 If no activation, transport FIT-A left and right to the FIT lab 23/R-002 (Meyrin). Transport to be arranged by FIT team

5.10 Close this task.