

1. PROJECT CODE ALICE		ALICE TASK DESCRIPTION		
2. EDMS ID. XXXX		3. TASK NO. ITS220708_008		4. PAGE 1 OF 23
5. DISCREPANCY REPORT SHEET(S) NUMBER(S)				
6. CATEGORY DETECTOR		7. PART NAME		8. SERIAL NUMBER
9. APPLICABLE DOCUMENTS				
10. TASK TITLE ITS Outer Barrel (OB) deinstallation				
11. OPER SEQ. NO.	12. OPERATIONS (Print, Type, or Write Legibly)			13. NOTE QA/PE
	<u>SCOPE</u>			
	<p>The purpose of the present document is to provide information and guidelines for the deinstallation of OB BOTTOM and TOP of the ITS2 Detector in the ALICE cavern, inside the Cage ALICE TPC bore. This procedure applies to the detector deinstallation during LS3.</p> <p style="text-align: center;"><u>WARNING</u></p> <p style="text-align: center;">This procedure requires working in a radiation controlled area. All Safety regulation and procedures shall be followed.</p> <p style="text-align: center;">This procedure requires exposure of the beryllium beam pipe. Only authorized personnel shall be involved.</p> <p style="text-align: center;">Fence the miniframe around the working area to limit the access only to personnel involved in the intervention.</p> <p style="text-align: center;">Suspend any other activity in L3 and on the miniframe.</p> <p style="text-align: center;">Electrical power supply shall be isolated and secured using Lock- Out Tag-Out (LOTO) procedure prior to intervention. Work can start only after verification of absence of voltage.</p>			
14. ORIGINATOR Massimo Angeletti		15. TASK PROJECT ENGINEER		
16. ALICE PROJECT ENGINEER Corrado Gargiulo		17. QUALITY-SAFETY ENGINEER Elisa Laudi / Klaus Barth		
18. ALICE INTEGRATION		19. ALICE TECHNICAL COORDINATOR Arturo Tauro		
20. TASK CLOSED ACCEPTANCE SIGNATURE				21. DATE

APPROVAL (Printed or Typed and Signed)

ALICE TASK SHEET
CONTINUATION PAGE

3. TASK SHEET NO

ITS220708_008

5. DISCREPANCY NO.

11. OPER
SEQ. NO.12. OPERATIONS
(Print, Type, or Write Legibly)

13. NOTE QA/PWE

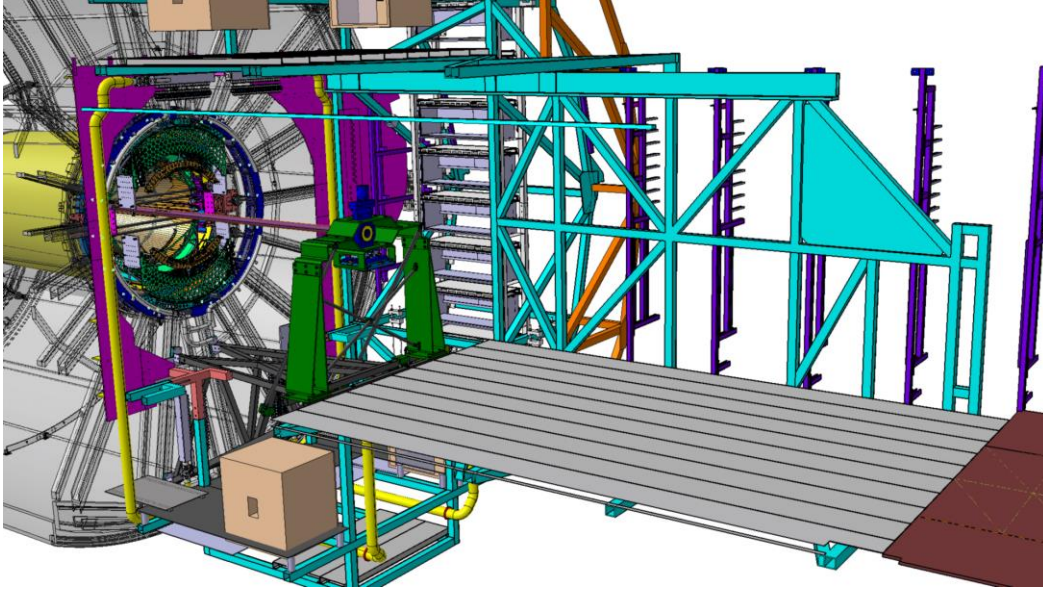

1. Required hardware and CAD model support

Assembly drawings	CDD number/ ST
ITS insertion-assembly on the Miniframe	ALIITSUP1029
IB OB MFT assembly	ST1327332_01
ITS support tooling for OB insertion	ALIITSUP1005
Cage clamps for OB insertion/extraction	ALIITSUP1028
OB integration	
OB Insertion Chassis (Top & Bottom)	ALIITSUP0957
OB Shipping Chassis (Top & Bottom)	ALIITSUP1049
OB Assembly Chassis	ALIITSUP1145
ITS rotator - OB on rotator	ALIITSUP1050

Readiness of the assembly tools from document: {EXCEL summary}

Open this Task Sheet.

2. Preparation

2.1 Obtain authorization from ALICE Technical Coordination to start the task.

2.2 Verify that the following de-installation tasks are completed:

- Open PX24 plug
- Deinstallation UX25 shielding

ALICE TASK SHEET

CONTINUATION PAGE

3. TASK SHEET NO

ITS220708_008

5. DISCREPANCY NO.

11. OPER
SEQ. NO.12. OPERATIONS
(Print, Type, or Write Legibly)

13. NOTE QA/PWE

- Deinstallation Miniframe hardware (including Compensator magnet, ZEM, BLM, FIT.A and RB24 Beampipe).
- Deinstallation of IB detector.

2.3 Verify that the areas between the Cage and Vacuum Valve support on the Miniframe are clear. If there is any hardware on the way to the detector installation contact ALICE Technical Coordination for removal.

2.4 Verify that the MNF is equipped for ITS deinstallation (ALIITSUP1031). Verify that the components of the *ITS insertion - assembly on the miniframe* (ALIITSUP1029) are installed, available and inspected:

1. *Manual lifting devices* (ALIITSUP0848)
2. *Top guiding bars* (ST1217085, ST1217060).
3. *Guiding support for chassis during its insertion* (ALIITSUP1030).
4. *Rear support for the chassis before insertion* (ALIITSUP0752).
5. *Lifting device with threaded rod* (ALIITSUP0862)
6. *Floor with rails* (ALIITSUP0607, ALIITSUP0605, ALIITSUP0599, ALIITSUP0598, ALIITSUP0595).
7. *External camera system* (ALIITSUP1046).

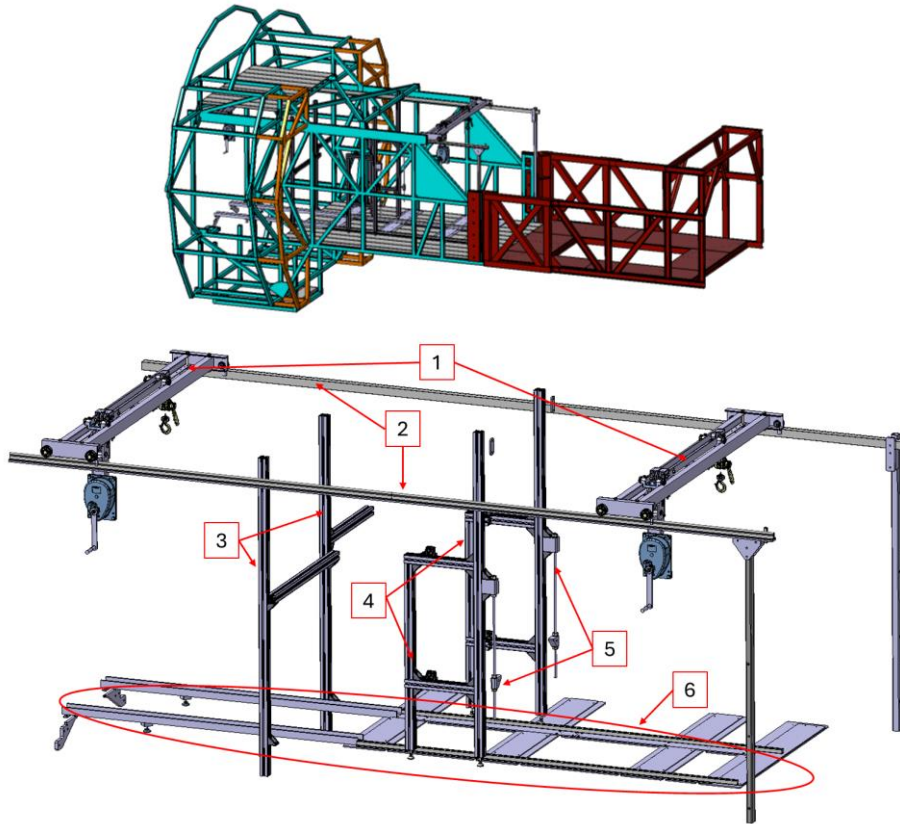

ITS insertion assembly tooling (update with camera system)

ALICE TASK SHEET

CONTINUATION PAGE

3. TASK SHEET NO

ITS220708_008

5. DISCREPANCY NO.

11. OPER
SEQ. NO.12. OPERATIONS
(Print, Type, or Write Legibly)

13. NOTE QA/PWE

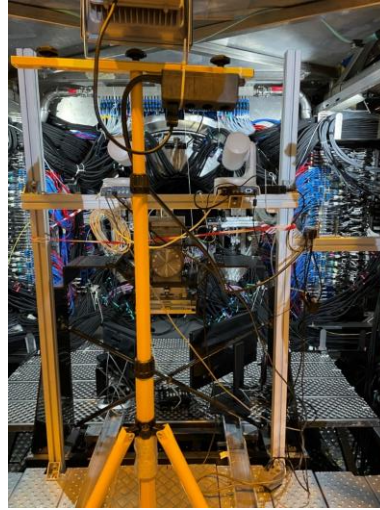

External camera system.

2.5

Verify that the following tools for extraction are available and inspected in the miniframe:

- *Support tooling for OB and PP2 extraction/insertion (ALIITSUP1005)*
- *Cage clamps for OB insertion/extraction (ALIITSUP1028)*
- *End fixing tool (ALIITSUP0732)*
- *Special key (ST1343308)*

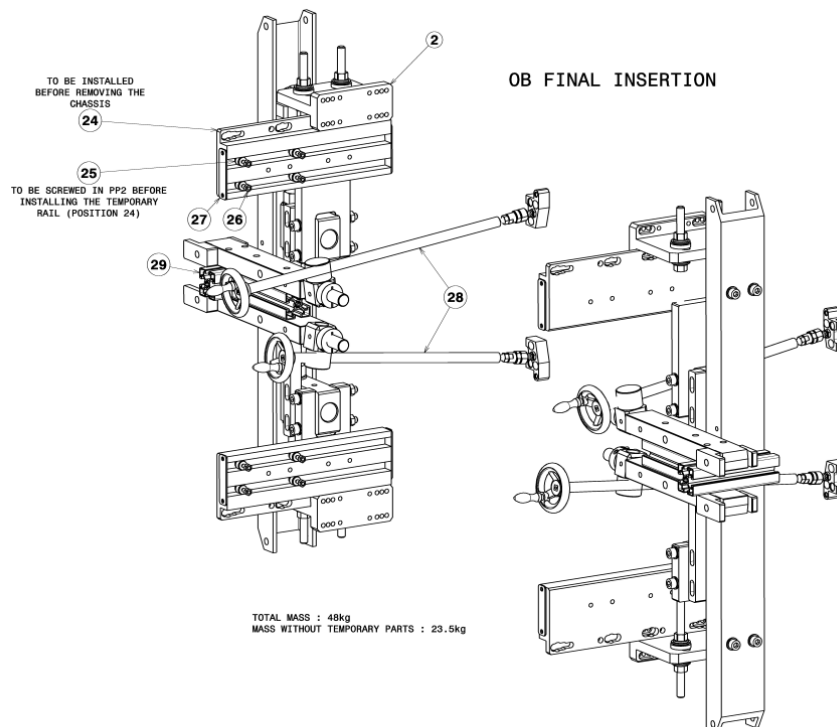

Support tooling for OB and PP2 extraction/insertion (ALIITSUP1005)

ALICE TASK SHEET
CONTINUATION PAGE

3. TASK SHEET NO

ITS220708_008

5. DISCREPANCY NO.

11. OPER
SEQ. NO.12. OPERATIONS
(Print, Type, or Write Legibly)

13. NOTE QA/PWE

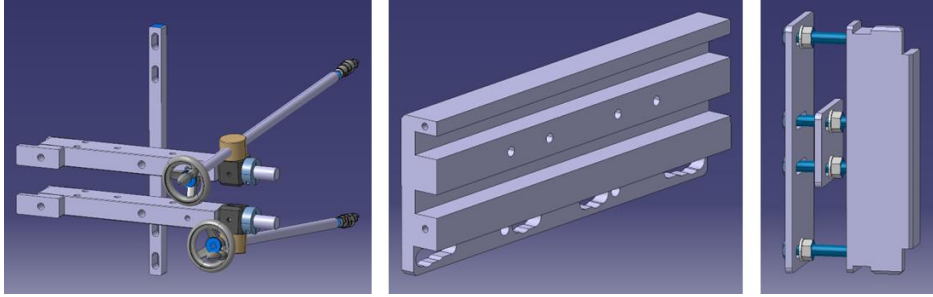

(Left) 2x insertion tooling – OB position (ALIITSUP1004), (Center) temporary rail for patch panel insertion (ALIITSUP0744) and (Right) Cage clamps for OB insertion/extraction (ALIITSUP1028).

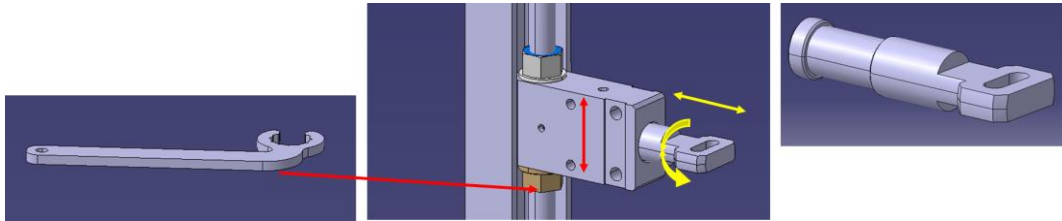

(Left) Special key (ST1343308), (center) Vertical adjustment, (right) end fixing tool (ALIITSUP0732).

2.6 Verify that for both the half-barrels, cables, cooling pipes and air pipes are disconnected and sealed/capped at Patch Panel 2 (a-side).

3. **OB: separation**

The separation of the two half-detectors, which have an interface clearance of approximately one millimeter, requires a precise, manually controlled movement over a distance of nearly 4 meters. During this operation, the camera system monitoring the interface between the two half-barrels must be continuously used. Particular attention must be paid to moving the half-barrel patch panels synchronously and to avoiding any misalignment of the cage.

WARNING

The risks associated with this activity are limited to mechanical hazards, including handling of components, use of dedicated hand tools, work in a confined underground environment, working in a radiation-controlled area, and potential exposure to the beryllium beam pipe.

3.1 Remove the *cage closing crosses* (ALIITSUP0242) and install the two *cage clamps for OB insertion/extraction* (ALIITSUP1028) without changing the cage position.

ALICE TASK SHEET

CONTINUATION PAGE

3. TASK SHEET NO

ITS220708_008

5. DISCREPANCY NO.

11. OPER
SEQ. NO.12. OPERATIONS
(Print, Type, or Write Legibly)

13. NOTE QA/PWE

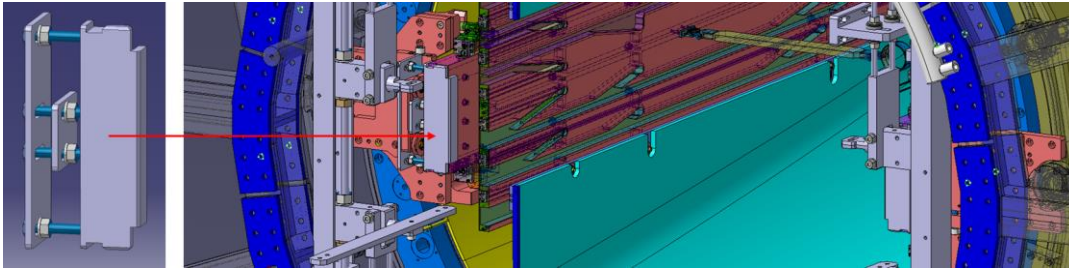

Position of the cage clamps for OB insertion/extraction (ALIITSUP1028)

- 3.2 Install the 2x8 *temporary roller assy for OB-PP2* (ALIITSUP0971) of the halves.

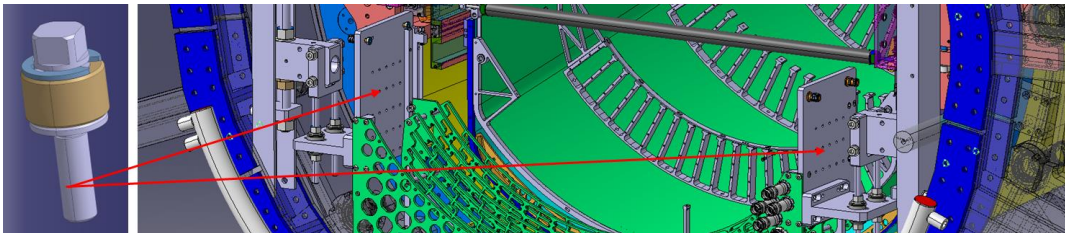

Position of the temporary roller assy for OB-PP2 (ALIITSUP0971)

- 3.3 Install the *support tooling for OB and PP2 insertion/extraction* (ALIITSUP1005) system in configuration “OB Final Insertion”, which includes the installation of the 4x *insertion tooling – OB position* (ALIITSUP1004, ref1) and the 4x *temporary rails for patch panel insertion* (ALIITSUP0744, ref2). Reinforce the assembly adding the *L shape roads* (ref3).

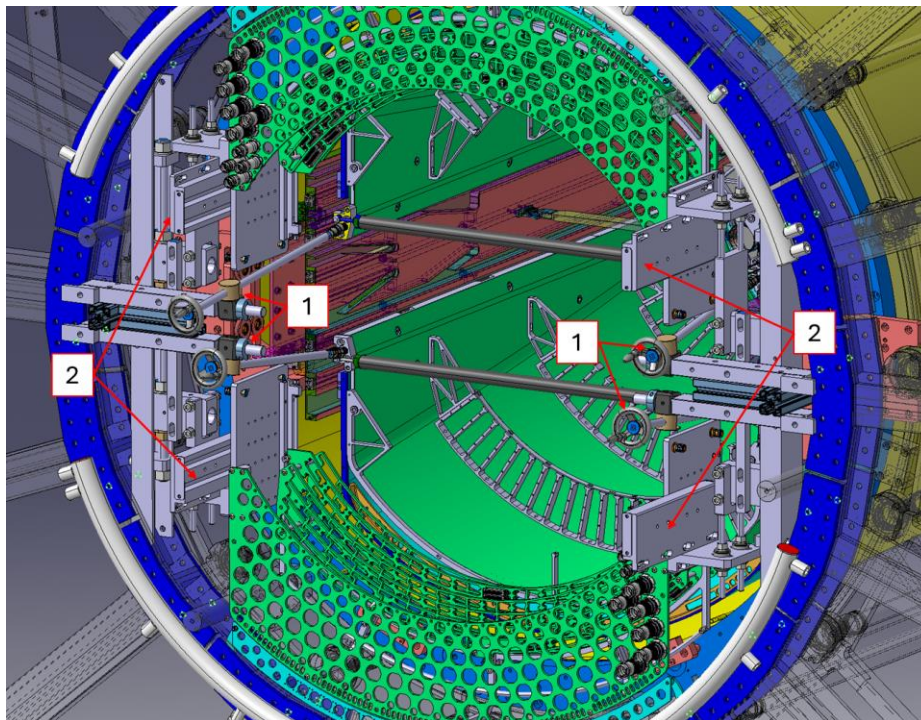

ALICE TASK SHEET

CONTINUATION PAGE

3. TASK SHEET NO

ITS220708_008

5. DISCREPANCY NO.

11. OPER
SEQ. NO.12. OPERATIONS
(Print, Type, or Write Legibly)

13. NOTE QA/PWE

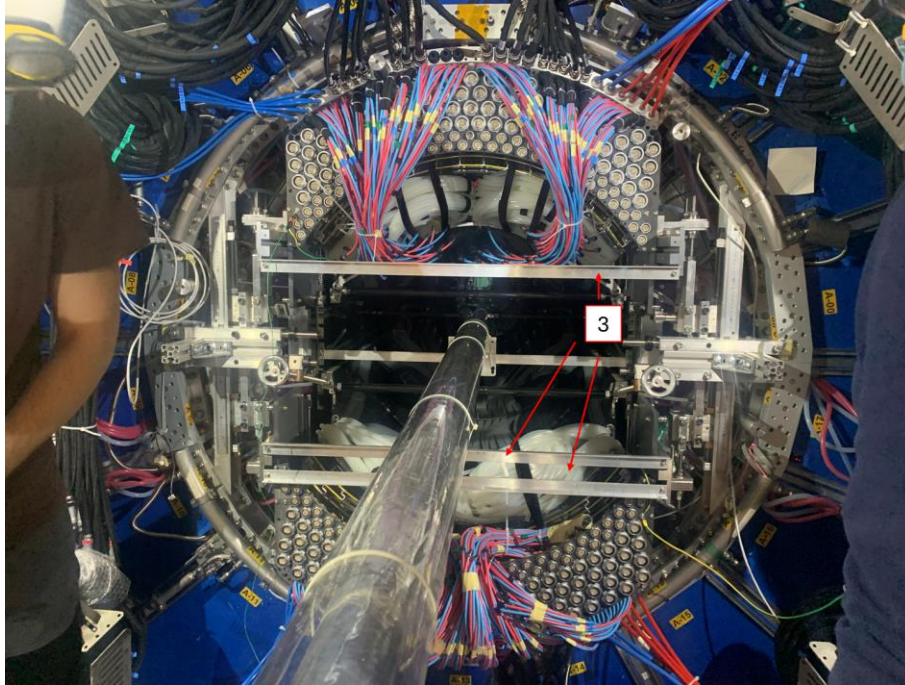

Support tooling for OB and PP2 insertion/extraction (ALIITSUP1005) system before extraction.

- 3.4 Verify that the 4x *insertion tooling – OB position* (ALIITSUP1004) are well connected and ready to hold the OB half-barrels. Remove the 2x2 *barrel push bars* (ALIITSUP0971) and unlock the PP2.

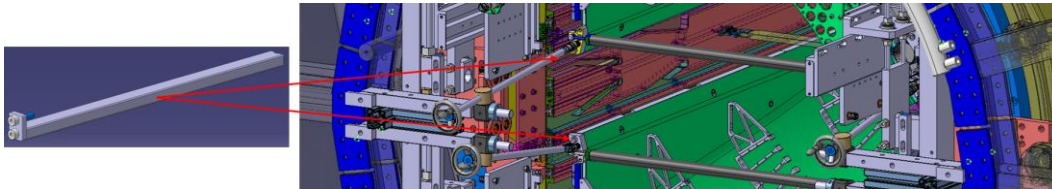

(Left) Push bar (ALIITSUP0971) and (Right) position of 2x2 push bars.

- 3.5 Pull back both half-barrels at the beginning of the slope. Start with the OB Top, check carefully the interface top/bottom by means of the *camera system*.

ALICE TASK SHEET
CONTINUATION PAGE

3. TASK SHEET NO

ITS220708_008

5. DISCREPANCY NO.

11. OPER
SEQ. NO.12. OPERATIONS
(Print, Type, or Write Legibly)

13. NOTE QA/PWE

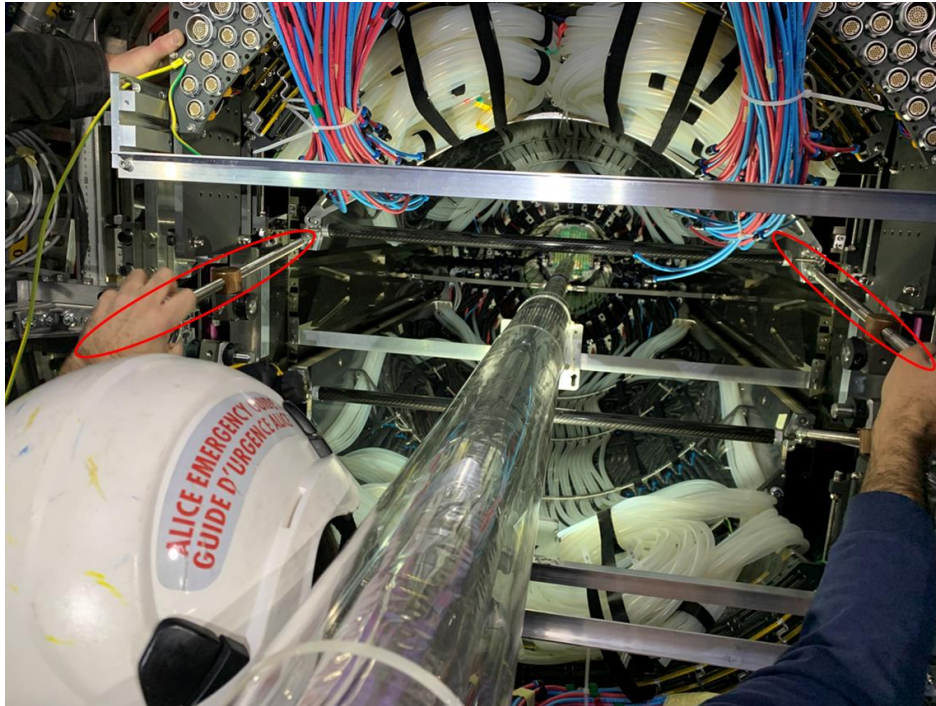

Extraction of the OB Top using the two manually operated insertion tooling – OB position (ALIITSUP1004).

ALICE TASK SHEET

CONTINUATION PAGE

3. TASK SHEET NO

ITS220708_008

5. DISCREPANCY NO.

11. OPER
SEQ. NO.12. OPERATIONS
(Print, Type, or Write Legibly)

13. NOTE QA/PWE

4. OB Top: extraction

The extraction of the OB Top, a large and heavy component, requires careful transfer from the cage to its dedicated chassis. The chassis must be precisely aligned with the cage to allow safe extraction of the OB Top and its insertion into the chassis. Using manual lifting devices, the chassis is then guided over the beam pipe and its valve support. Care must be taken to avoid any collision with these elements.

WARNING:

The risks associated with this activity are limited to mechanical hazards, including handling of components, use of dedicated hand tools, work in a confined underground environment, working in a radiation-controlled area, and potential exposure to the beryllium beam pipe.

- 4.1 Lower the **OB Top chassis** onto the miniframe and connect it to the **manual lifting devices** (ALIITSUP0848). OB Top chassis shall be assembled for insertion/extraction (ALIITSUP0957).



OB Top chassis for extraction (ALIITSUP0957) before (Left) and after (Right) to be lifted by the manual lifting device (ALIITSUP0848).

- 4.2 Move the back of the OB top chassis onto the **rear support for the chassis** (ALIITSUP0752) and the **lifting device with threaded rod** (ALIITSUP0862), while the front part near the cage. Adjust the height of the **manual lifting device** if required.

ALICE TASK SHEET

CONTINUATION PAGE

3. TASK SHEET NO

ITS220708_008

5. DISCREPANCY NO.

11. OPER
SEQ. NO.12. OPERATIONS
(Print, Type, or Write Legibly)

13. NOTE QA/PWE

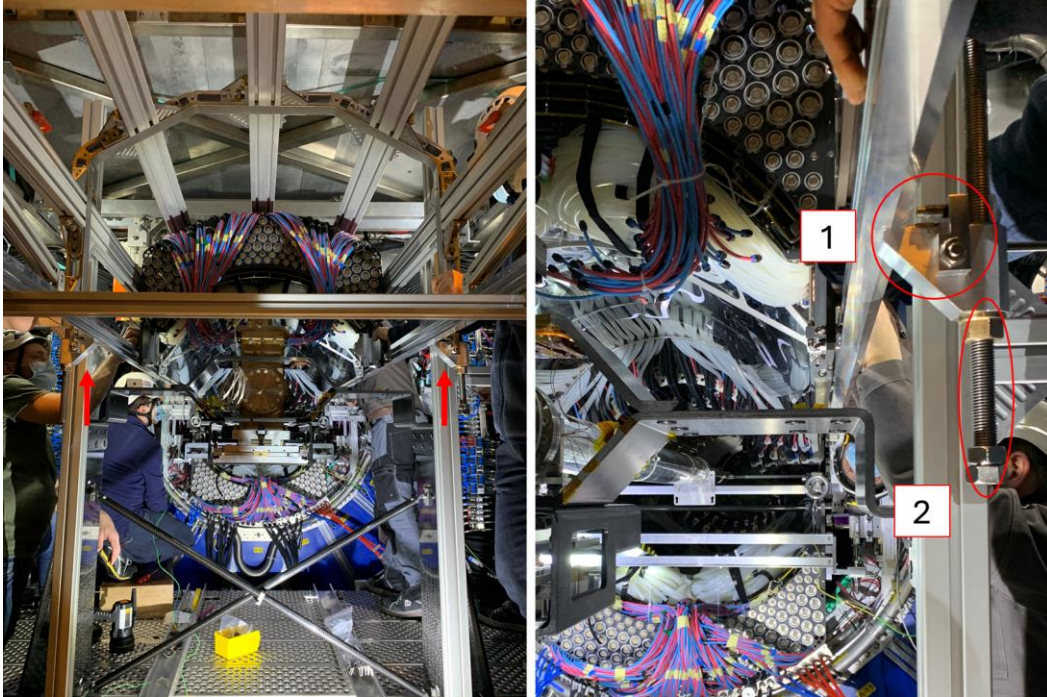

- 4.3 Adjust the height and the lateral position of the front part of the **OB Top chassis**. Install the **end fixing foot** (ALIITSUP0732). Use **special key** (ST1343308) to adjust the height and the end fixing foot itself to adjust the lateral position.

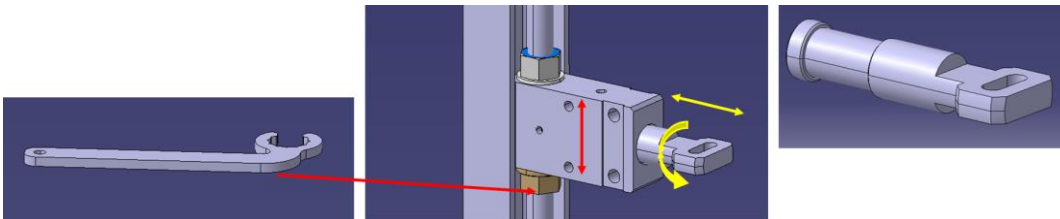

(Left) Special key (ST1343308), (center) Vertical adjustment, (right) end fixing tool (ALIITSUP0732).

- 4.4 Install the 2x top cage extension parts (**L profile 60x60x10**, ALIITSUP0742, ref1) and fix the front part of OB Top chassis onto it.

ALICE TASK SHEET

CONTINUATION PAGE

3. TASK SHEET NO

ITS220708_008

5. DISCREPANCY NO.

11. OPER
SEQ. NO.12. OPERATIONS
(Print, Type, or Write Legibly)

13. NOTE QA/PWE

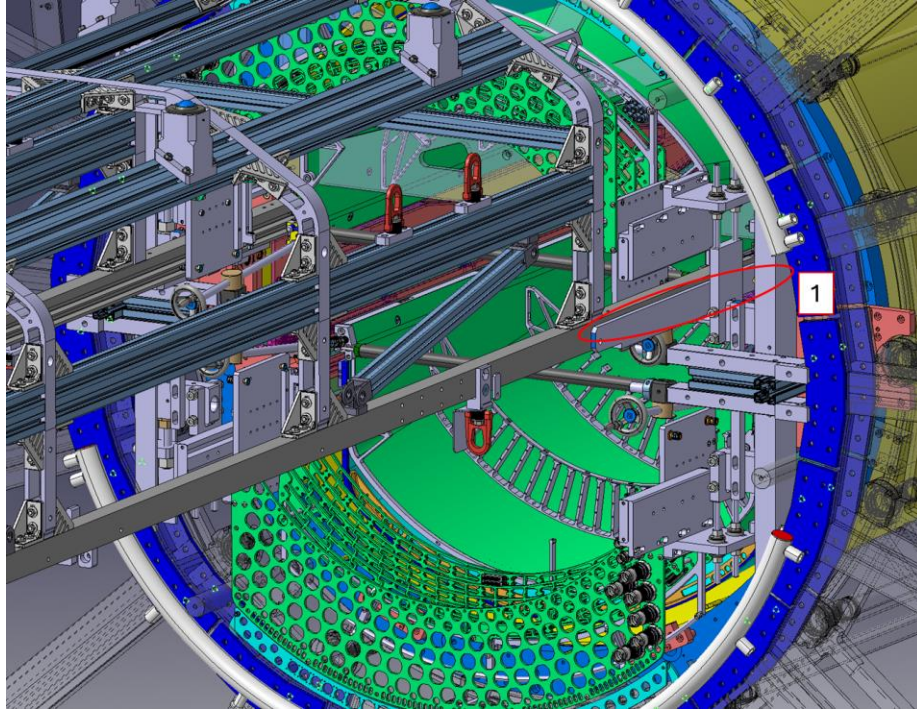

4.5 Remove the top *L shape road* and the 2x *insertion tooling – OB position* (ALIITSUP1004) of the OB Top.

4.6 Extract the OB Top by sliding it completely inside the *OB Top Chassis*.

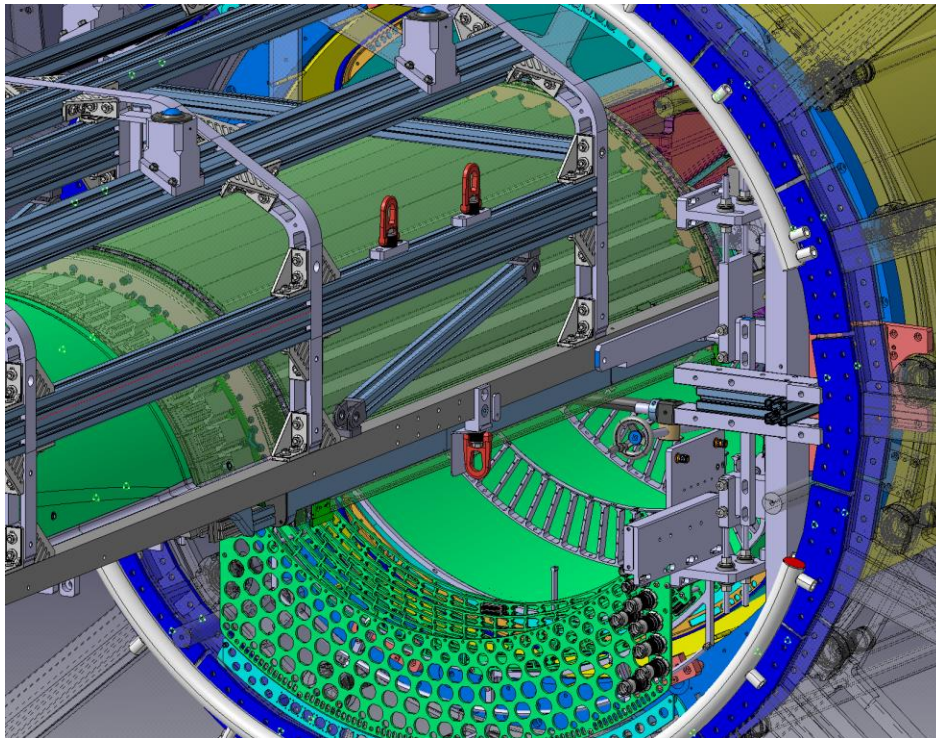

ALICE TASK SHEET
CONTINUATION PAGE

3. TASK SHEET NO

ITS220708_008

5. DISCREPANCY NO.

11. OPER
SEQ. NO.12. OPERATIONS
(Print, Type, or Write Legibly)

13. NOTE QA/PWE

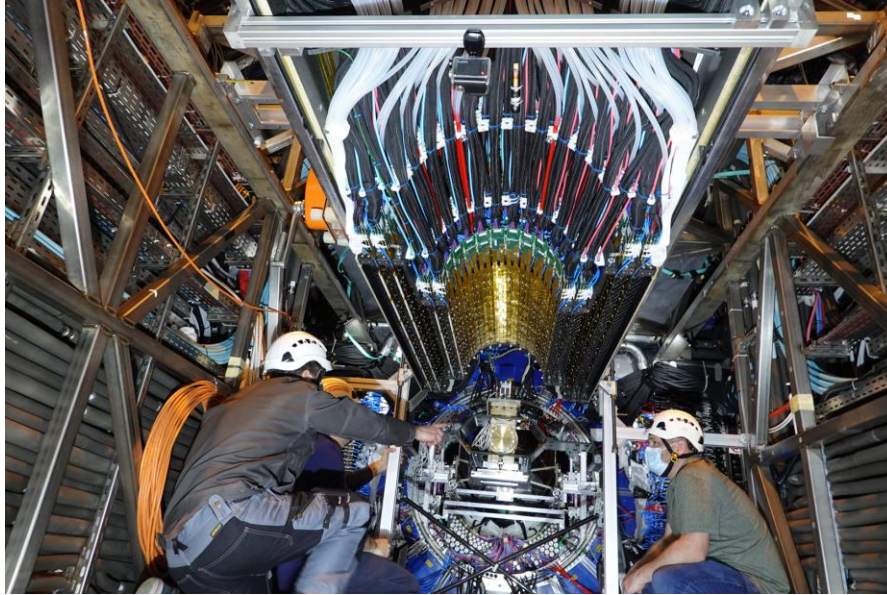

- 4.7 Lock the **OB Top** inside the **OB Top Chassis**.
- 4.8 Reinstall the top **cage closing cross** (ALIITSUP0242).
- 4.9 Unlock the **OB Top chassis** from the 2x top cage extension parts (**L profile 60x60x10**, ALIITSUP0742).
- 4.10 Install the **A-side support of the OB Top chassis** (large bosh profiles connected to the miniframe lateral walls).
- 4.11 and connect them at the end extremity of the miniframe.
- 4.12 Move the **OB Top chassis** backward by sliding on the **rear support for the chassis** (ALIITSUP0752) and the 2x top cage extension parts until it reaches a safe position (outside the TPC end-wheel).
- 4.13 Lift the **OB Top chassis** using the **manual lifting devices**. The chassis shall be maintained at zero-degree orientation. Ensure that no contact with the beam pipe occurs.
- 4.14 Move the **OB Top chassis** to the opposite extremity of the **top guiding bars** (ST1217085, ST1217060).
- 4.15 Add Bosh profiles of the **OB Top Chassis** protecting the inner part of the detector.

ALICE TASK SHEET
CONTINUATION PAGE

3. TASK SHEET NO

ITS220708_008

5. DISCREPANCY NO.

11. OPER
SEQ. NO.12. OPERATIONS
(Print, Type, or Write Legibly)

13. NOTE QA/PWE



- 4.16 Place the **OB Top Chassis** on the **A-side support of the OB Top chassis** (large bosh profiles connected to the miniframe lateral walls).
- 4.17 Remove the 2x top cage extension parts (**L profile 60x60x10**, ALIITSUP0742) and the **end fixing foot** (ALIITSUP0732).

5. OB Top: Transfer to Low Beta Platform

Once clear of the ALICE central area and positioned at the opposite end of the miniframe, the OB Top is transferred to the Low Beta Platform. Care must be taken when attaching the crane and ensuring a sufficiently low speed to maintain the chassis in a 0° orientation. Once on the Low Beta Platform, the chassis is connected to the ITS rotator, safely rotated, and then secured to the shipping base, where damping springs are installed to absorb potential vibrations during transport.

WARNING:

The risks associated with this activity are limited to mechanical hazards, including handling of components, use of dedicated hand tools, work in a confined underground environment, working in a radiation-controlled area, and potential exposure to the beryllium beam pipe. The cranes operated in this procedure shall be performed by a crane operator trained for this specific procedure.

ALICE TASK SHEET
CONTINUATION PAGE

3. TASK SHEET NO.

ITS220708_008

5. DISCREPANCY NO.

11. OPER
SEQ. NO.12. OPERATIONS
(Print, Type, or Write Legibly)

13. NOTE QA/PWE

- 5.1 Contact ALICE Technical Coordination for authorization to move the half-barrel to the Low Beta Platform. Use the crane at minimum speed.
- 5.2 Ensure that the Low Beta Platform area is fenced and the access is restricted to the ITS deinstallation team.
- 5.3 Ensure that the bottom part of the *barrel shipping chassis OB* (ALIITSUP1049), the *ITS rotator – reducer side* (ALIITSUP0833) and the *ITS rotator - free-wheel side* (ALIITSUP0834) are in position on the Low Beta Platform.
- 5.4 Connect the miniframe bridge crane, do not tension it.
- 5.5 Verify that the *OB Top chassis* is fully supported by the *A-side support of the OB Top chassis* (large bosh profiles connected to the miniframe lateral walls), and release tension, if any, to the manual lifting devices and disconnect them.
- 5.6 Remove the *manual lifting device* near the extremity of *top guiding shafts* to allow *OB Top chassis* movement along the miniframe length.

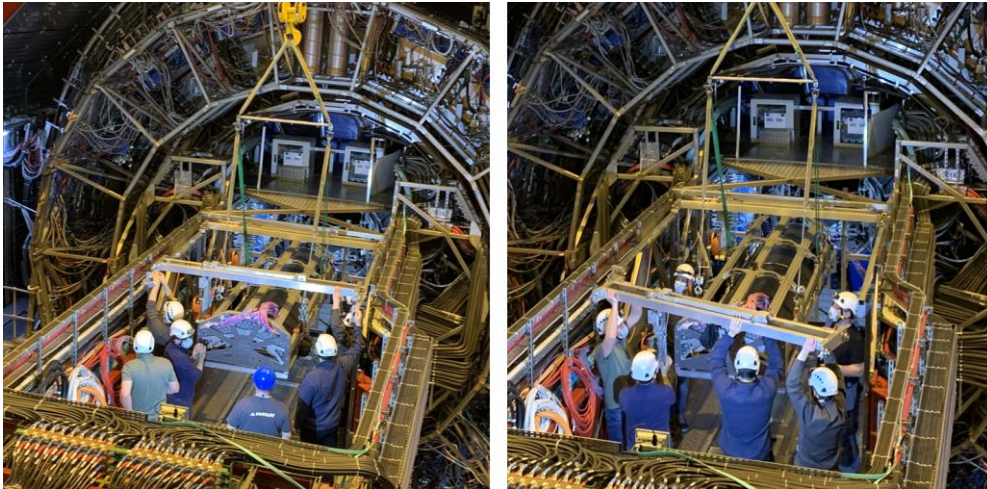

- 5.7 Tension and lift the chassis with the miniframe bridge crane to the Low Beta Platform. The chassis is to be lifted in the 0-degree orientation. Use the crane at minimum speed.

ALICE TASK SHEET

CONTINUATION PAGE

3. TASK SHEET NO

ITS220708_008

5. DISCREPANCY NO.

11. OPER
SEQ. NO.12. OPERATIONS
(Print, Type, or Write Legibly)

13. NOTE QA/PWE

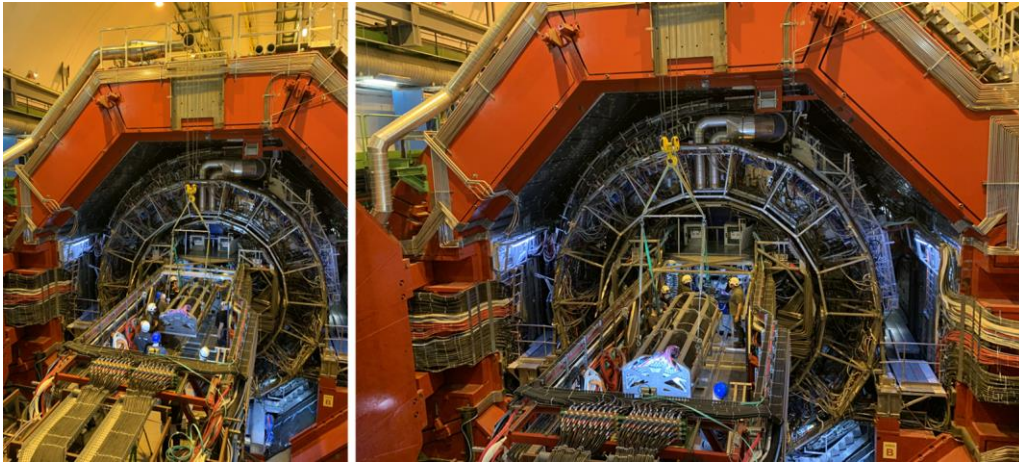

- 5.8 Mount the *ITS rotator – reducer side* (ALIITSUP0833) and the *ITS rotator - free-wheel side* (ALIITSUP0834) onto the chassis

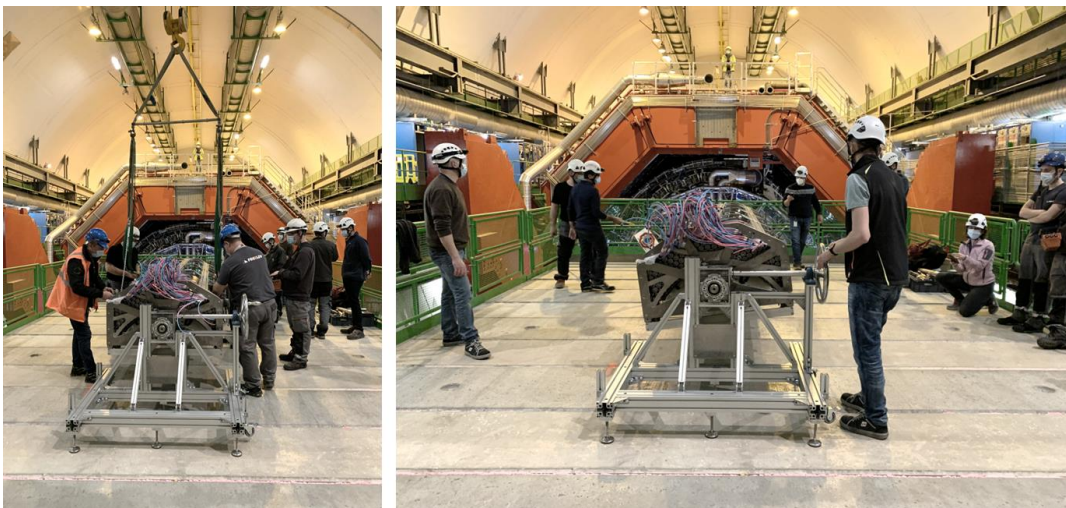

- 5.9 Disconnect the miniframe bridge crane.

- 5.10 Rotate the chassis (180 °).

ALICE TASK SHEET

CONTINUATION PAGE

3. TASK SHEET NO

ITS220708_008

5. DISCREPANCY NO.

11. OPER
SEQ. NO.12. OPERATIONS
(Print, Type, or Write Legibly)

13. NOTE QA/PWE



- 5.11 Proceed to reconnect the miniframe bridge crane to the lifting points on the chassis.
- 5.12 Tension the slings and disconnect the *ITS rotator – reducer side* (ALIITSUP0833) and the *ITS rotator - free-wheel side* (ALIITSUP0834).



- 5.13 Place the chassis on the base part of the *barrel shipping chassis OB* (ALIITSUP1049).
- 5.14 Align the base part of the *barrel shipping chassis OB* (ALIITSUP1049) under the insertion chassis using jacks. Lower and connect the chassis to the *barrel shipping chassis OB* (ALIITSUP1049) by screwing it to the steel-spring dumpers.

ALICE TASK SHEET
CONTINUATION PAGE

3. TASK SHEET NO

ITS220708_008

5. DISCREPANCY NO.

11. OPER
SEQ. NO.12. OPERATIONS
(Print, Type, or Write Legibly)

13. NOTE QA/PWE



5.15 Disconnect the miniframe bridge crane.

6. OB Top: Transfer to SX2 hall

Once the OB Top is secured in its shipping chassis, the P2 crane is connected to its base. Care must be taken when attaching the crane and operating at sufficiently low speed to maintain the chassis at 0° orientation. Once the OB Top is in the SX2 hall, it is loaded into the truck. Temperature and humidity sensors, as well as shock loggers, must travel with the chassis until the next reinstallation.

WARNING:

The risks associated with this activity are limited to mechanical hazards, including handling of components, use of dedicated hand tools, work in a confined underground environment, and working in a radiation-controlled area. The cranes operated in this procedure shall be performed by a crane operator trained for this specific procedure.

- 6.1 Contact ALICE Technical Coordination for authorization to lift the OB TOP half to SX2 hall. Use crane at minimum speed.
- 6.2 Ensure that the SX2 hall area is fenced and the access is restricted to ITS deinstallation team.
- 6.3 Attach the P2 Crane at the base of the *barrel shipping chassis OB* (ALIITSUP1049).

ALICE TASK SHEET

CONTINUATION PAGE

3. TASK SHEET NO

ITS220708_008

5. DISCREPANCY NO.

11. OPER
SEQ. NO.12. OPERATIONS
(Print, Type, or Write Legibly)

13. NOTE QA/PWE



- 6.4 Lift the *barrel shipping chassis OB* (ALIITSUP1049) up to the SX2 hall area. The Transport chassis is to be lifted in the 0-degree orientation. Use the crane at minimum speed.



- 6.5 Place the *barrel shipping chassis OB* (ALIITSUP1049) inside the Truck. Install temperature and humidity sensors and shock loggers.

ALICE TASK SHEET
CONTINUATION PAGE

3. TASK SHEET NO

ITS220708_008

5. DISCREPANCY NO.

11. OPER
SEQ. NO.12. OPERATIONS
(Print, Type, or Write Legibly)

13. NOTE QA/PWE



6.6 Disconnect the P2 Crane.

6.7 Transport the OB Top to the **storage location**.

7. OB Bottom: extraction

The extraction of the OB Bottom, a large and heavy component, requires careful transfer from the cage to its dedicated chassis. The chassis must be precisely aligned with the cage to allow safe extraction of the OB Bottom and its insertion into the chassis. The chassis is then guided along floor rails beneath the beam pipe and its valve support. Particular care must be taken to avoid any collision with these elements.

WARNING:

The risks associated with this activity are limited to mechanical hazards, including handling of components, use of dedicated hand tools, work in a confined underground environment, working in a radiation-controlled area, and potential exposure to the beryllium beam pipe.

7.1 Inspect the area between the Cage, Valve Support to ensure no obstruction.

7.2 Reinstall the **external camera system**.

7.3 Dismount the valve support cross (ALIITSUP0777)

ALICE TASK SHEET
CONTINUATION PAGE

3. TASK SHEET NO

ITS220708_008

5. DISCREPANCY NO.

11. OPER
SEQ. NO.12. OPERATIONS
(Print, Type, or Write Legibly)

13. NOTE QA/PWE



- 7.4 Bring the **OB Bottom chassis** down on the miniframe area place it inside the **guiding support for chassis** (ALIITSUP1030).
- 7.5 Move the **OB Bottom chassis** next the Cage. Carefully ensure that no contact occurs with the beam pipe.
- 7.6 Adjust the height and the lateral position of the front part of the **OB Bottom chassis**. Install the **end fixing foot** (ALIITSUP0732). Use **special key** (ST1343308) to adjust the height and the end fixing foot itself to adjust the lateral position.

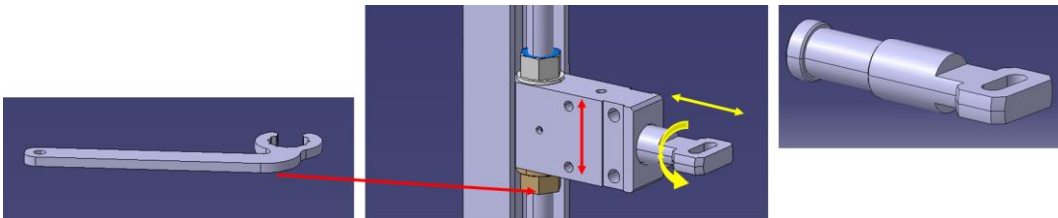

(Left) Special key (ST1343308), (center) Vertical adjustment, (right) end fixing tool (ALIITSUP0732).

- 7.7 Remove the **L shape roads** and the 2x **insertion tooling – OB position** (ALIITSUP1004) of the OB Top.
- 7.8 Extract the OB Bottom by sliding it completely inside its chassis.

ALICE TASK SHEET
CONTINUATION PAGE

3. TASK SHEET NO

ITS220708_008

5. DISCREPANCY NO.

11. OPER
SEQ. NO.12. OPERATIONS
(Print, Type, or Write Legibly)

13. NOTE QA/PWE

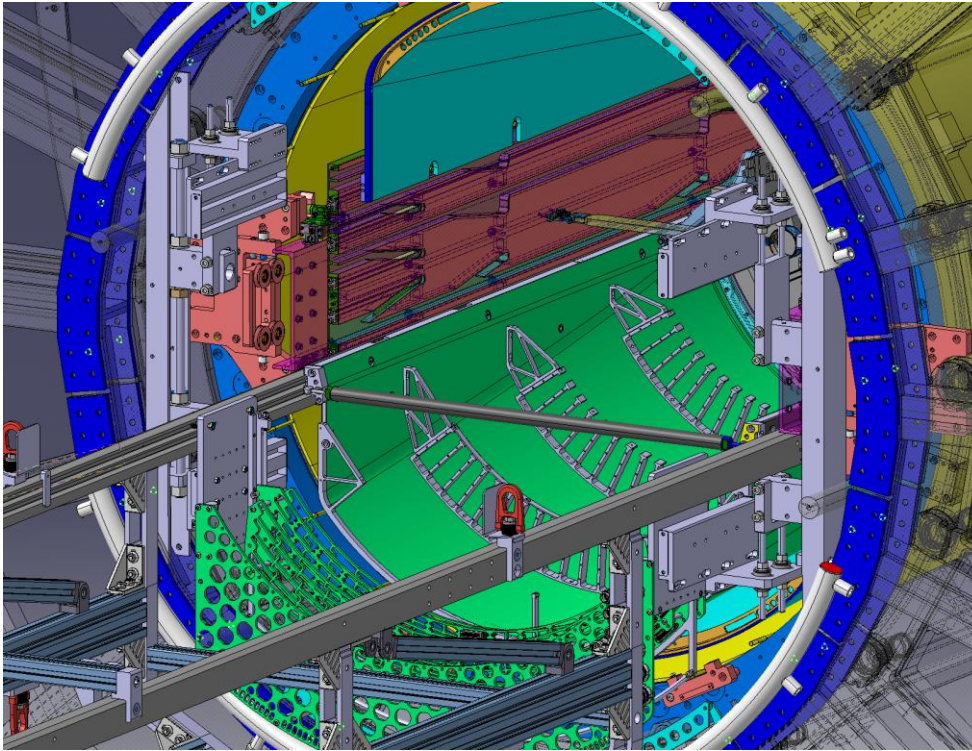

- 7.9 Reinstall the bottom **cage closing cross** (ALIITSUP0242).
- 7.10 Lock the OB Bottom inside the **OB Bottom Chassis**.
- 7.11 Move the OB chassis back, through the chassis rails, until it reaches the other extremity of the miniframe. Carefully ensure that no contact occurs with the beam pipe.
- 7.12 Add Bosh profiles of the **OB Bottom Chassis** protecting the inner part of the detector.
- 7.13 Remove the end fixing foot (ALIITSUP0732).
- 8. OB Bottom: Transfer to Low Beta Platform**
Once clear of the ALICE central detector area and positioned at the opposite end of the miniframe, the OB Bottom is transferred to the Low Beta Platform. Care must be taken when attaching the crane and ensuring a sufficiently low speed to maintain the chassis in a 0° orientation. Once on the Low Beta Platform, the chassis is connected and secured to the shipping base, where damping springs are installed to absorb potential vibrations during transport.

WARNING:

The risks associated with this activity are limited to mechanical hazards,

ALICE TASK SHEET
CONTINUATION PAGE

3. TASK SHEET NO

ITS220708_008

5. DISCREPANCY NO.

11. OPER
SEQ. NO.12. OPERATIONS
(Print, Type, or Write Legibly)

13. NOTE QA/PWE

including handling of components, use of dedicated hand tools, work in a confined underground environment, working in a radiation-controlled area, and potential exposure to the beryllium beam pipe. The cranes operated in this procedure shall be performed by a crane operator trained for this specific procedure.

- 8.1 Contact ALICE Technical Coordination for authorization to move the half-barrel to the Low Beta Platform. Use the crane at minimum speed.
- 8.2 Ensure that the Low Beta Platform area is fenced and the access is restricted to ITS deinstallation team.
- 8.3 Ensure that the bottom part of the *barrel shipping chassis OB* (ST1353182) is in position on the Low Beta Platform.
- 8.4 Verify that the *manual lifting devices* are dismantled.
- 8.5 Connect the miniframe bridge crane, do not tension it.
- 8.6 Tension and lift the chassis with the miniframe bridge crane to the Low Beta Platform. The chassis is to be lifted in the 0-degree orientation. Use crane minimum speed.



- 8.7 Place the chassis on the base part of the *barrel shipping chassis OB* (ST1353182).
- 8.8 Lower and connect the chassis to the *barrel shipping chassis OB* (ST1353182) by screwing it to the steel-spring dumpers.

ALICE TASK SHEET
CONTINUATION PAGE

3. TASK SHEET NO

ITS220708_008

5. DISCREPANCY NO.

11. OPER
SEQ. NO.12. OPERATIONS
(Print, Type, or Write Legibly)

13. NOTE QA/PWE



8.9 Disconnect the miniframe bridge crane.

9. OB Bottom: Transfer to SX2 hall

Once the OB Bottom is secured in its shipping chassis, the P2 crane is connected to its base. Care must be taken when attaching the crane and operating at sufficiently low speed to maintain the chassis at 0° orientation. Once the OB Top is in the SX2 hall, it is loaded into the truck. Temperature and humidity sensors, as well as shock loggers, must travel with the chassis until the next reinstallation.

WARNING:

The risks associated with this activity are limited to mechanical hazards, including handling of components, use of dedicated hand tools, work in a confined underground environment, and working in a radiation-controlled area. The cranes operated in this procedure shall be performed by a crane operator trained for this specific procedure.

9.1 Repeat step 7 (OB Top: Transfer to SX2 hall) for OB Bottom.

10. Closure of the task

Once the removal of both OB half-barrels is complete, the miniframe area shall be cleaned and secured in preparation for the subsequent hardware deinstallation.

10.1 Verify that the following tools for extraction are removed

- *Support tooling for OB and PP2 extraction/insertion* (ALIITSUP1005)
- *Cage clamps for OB insertion/extraction* (ALIITSUP1028)
- *End fixing tool* (ALIITSUP0732)

10.2 Verify that the **cage closing crosses** (ALIITSUP0242) are installed.

10.3 Close this task.