



# B mixing: unexplored observables

Ulrich Nierste

Institute for Theoretical Particle Physics (TTP)

Karlsruhe Institute of Technology

FCC CP Violation Working Group

31 March 2026

Collaborative Research Center TRR 257



Particle Physics Phenomenology after the Higgs Discovery



# Meson-antimeson mixing

- The flavoured neutral mesons  $M = K, D, B_d, B_s$  mix with their antiparticles:
  - $\Rightarrow$  mass eigenstates  $\neq$  flavour eigenstates
  - $\Rightarrow$  damped  $M-\bar{M}$  oscillations
- gold mine for CP studies!

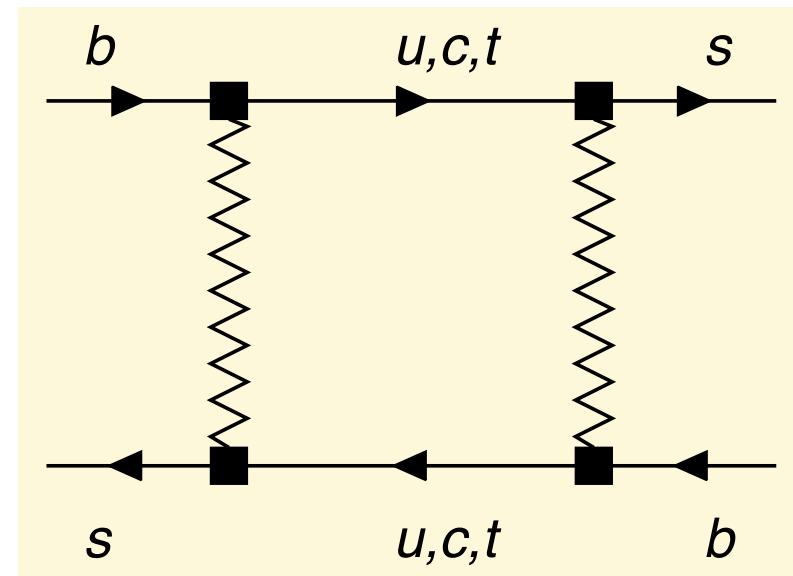
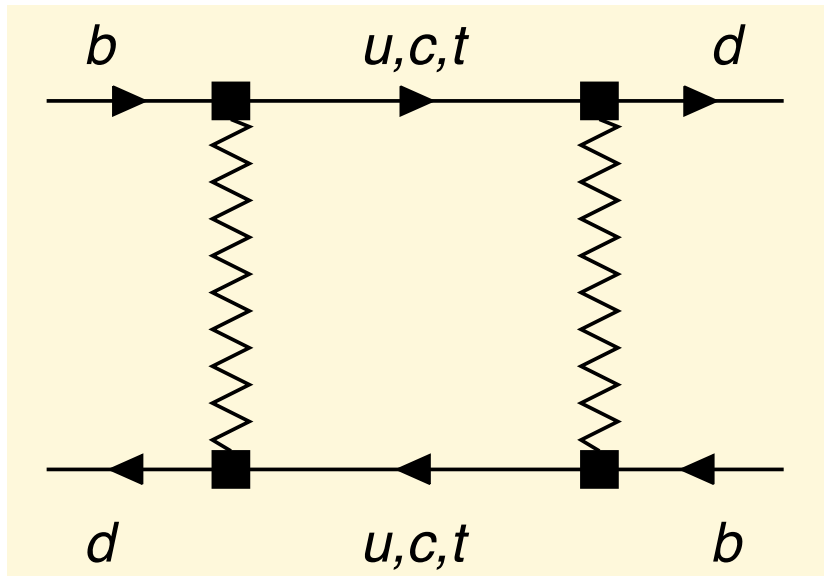

# $B - \bar{B}$ mixing

- $B_q - \bar{B}_q$  mixing involves the  $2 \times 2$  hermitian matrices  $M^q$  and  $\Gamma^q$ , where  $q = d$  or  $s$ .

- off-diagonal element  $M_{12}^q - i\frac{\Gamma_{12}^q}{2} \neq 0$   
 $\Rightarrow B_q - \bar{B}_q$  oscillations

- diagonalise  $M^q - i\frac{\Gamma^q}{2}$ :
 
$$\begin{aligned} |B_L\rangle &= p|B_s\rangle + q|\bar{B}_s\rangle \\ |B_H\rangle &= p|B_s\rangle - q|\bar{B}_s\rangle \end{aligned}$$
 with  $\begin{cases} L = \text{"light"} \\ H = \text{"heavy"} \end{cases}$

$|B_L\rangle$  and  $|B_H\rangle$  obey exponential decay laws:  $|B_{L,H}(t)\rangle = e^{-iM_{L,H}t - \Gamma_{L,H}t/2} |B_{L,H}\rangle$

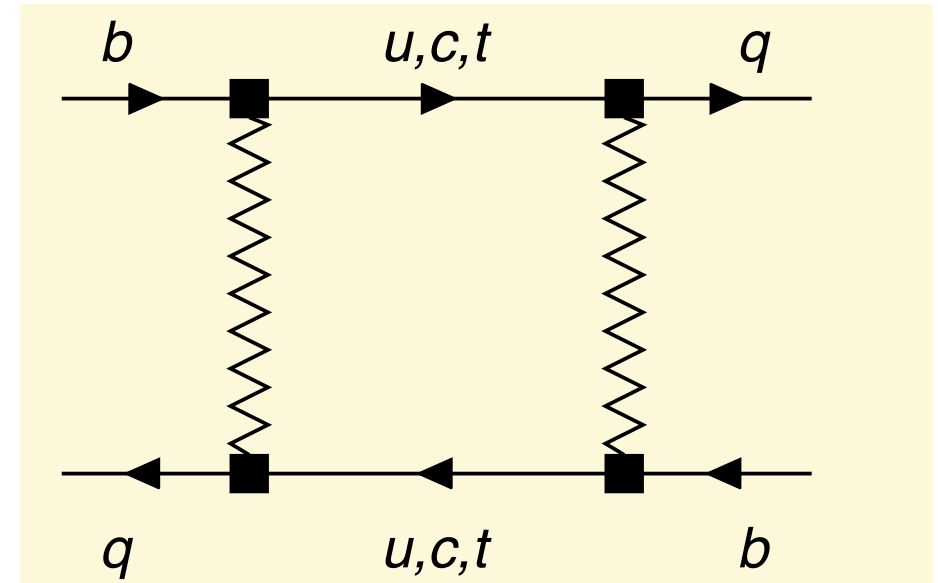

# $B - \bar{B}$ mixing

- Three universal physical quantities in  $B_q - \bar{B}_q$  mixing:

$$\left| M_{12}^q \right|, \quad \left| \Gamma_{12}^q \right|, \quad \phi_q \equiv \arg \left( -\frac{M_{12}^q}{\Gamma_{12}^q} \right) \quad \leftarrow \text{quantifies "CP violation in mixing"}$$

entering every  $B_q$  decay.

- Fourth quantity defined via a chosen exclusive decay:

$$\arg \left( M_{12}^q / (V_{cb} V_{cq}^*)^2 \right) \text{ from } B_d \rightarrow J/\psi K_S \text{ and } B_s \rightarrow J/\psi \phi \quad \leftarrow \text{quantifies "mixing-induced CP violation"}$$

Future: Get information on  $\arg M_{12}^q$  instead from

$$B_d \rightarrow \bar{D}^0 K_S \text{ and } B_s \rightarrow \bar{D}^0 \phi \text{ combined with } \gamma \text{ from } B^+ \rightarrow \bar{D}^0 K^+$$

$\Rightarrow$  no penguin pollution.

# $B - \bar{B}$ mixing

- Three universal physical quantities in  $B_q - \bar{B}_q$  mixing:

$$\left| M_{12}^q \right|, \quad \left| \Gamma_{12}^q \right|, \quad \phi_q \equiv \arg \left( -\frac{M_{12}^q}{\Gamma_{12}^q} \right) \leftarrow \text{quantifies "CP violation in mixing"}$$

- $|\Gamma_{12}^q| \ll |M_{12}^q| \Rightarrow$  expand in  $|\Gamma_{12}^q|/|M_{12}^q|$  from now on

- Determined from three observables:

- mass difference:  $\Delta m_q \equiv M_H^q - M_L^q \simeq 2 |M_{12}^q| \leftarrow \text{equals oscillation frequency}$

- width difference:  $\Delta \Gamma_q \equiv \Gamma_L^q - \Gamma_H^q \simeq 2 |\Gamma_{12}^q| \cos \phi_q \leftarrow \text{small!}$

- CP asymmetry in flavour-specific decays:  $a_{\text{fs}}^q = \frac{|\Gamma_{12}^q|}{|M_{12}^q|} \sin \phi_q \leftarrow \text{even smaller, since } \phi_q \ll 1$

# $\Delta\Gamma^q$ and $a_{\text{fs}}^q$

- Experimental situation (HFLAV 2024):

- $\Delta\Gamma^{s,\text{exp}} = (0.0781 \pm 0.0035) \text{ ps}^{-1}$

- $\Delta\Gamma^{d,\text{exp}} = (0.001 \pm 0.010) \text{ ps}^{-1}$

- $a_{\text{fs}}^{d,\text{exp}} = -0.0021 \pm 0.0017$

- $a_{\text{fs}}^{d,\text{exp}} = -0.0006 \pm 0.0028$

- Theory predictions are done in a double expansion in  $\Lambda_{\text{QCD}}/m_b$  and  $\alpha_s$ .

State of the art:  $m_b^0$ ,  $m_b^0\alpha_s$ , and  $m_b^0\alpha_s^2$  ← next-to-next-to-leading order, 3 loops  
well-known hadronic matrix elements  
from lattice QCD

$\Lambda_{\text{QCD}}/m_b$ : no QCD corrections yet, poorly known matrix elements

UN, Pascal Reeck, Vladyslav Shtabovenko, Matthias Steinhauser, *JHEP* 03 (2026) 094

- 2025 theory predictions:

$$a_{\text{fs}}^s = (2.27 \pm 0.13) \times 10^{-5}, \quad a_{\text{fs}}^d = - (5.19 \pm 0.30) \times 10^{-4}$$

Error dominated by unknown  $\alpha_s/m_b$  terms and poor  $1/m_b$  matrix elements.

- 2025 theory prediction:

$$a_{fs}^d = - (5.19 \pm 0.30) \times 10^{-4}$$

determines a circle in the  $(\bar{\rho}, \bar{\eta})$  plane of the unitarity triangle.

- Can test new physics from  $B_d - \bar{B}_d$  observables alone!

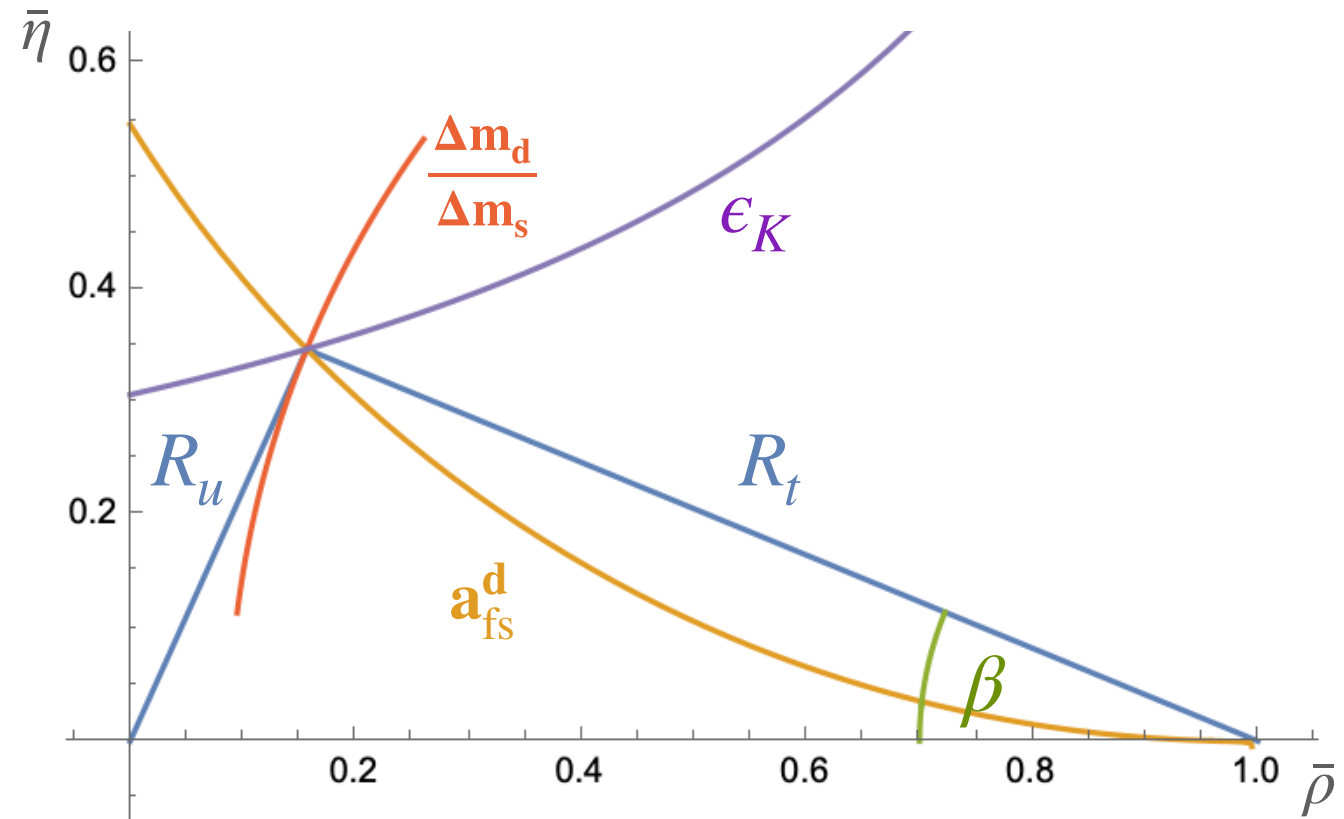

# $a_{\text{fs}}^d$ and $\Delta\Gamma^d$

Standard Model

$$a_{\text{fs}}^q \propto m_c^2/m_b^2 \sin\phi_q,$$

but new physics can easily lift this suppression!

Bands show uncertainty from NNLO piece, uncertainty from  $1/m_b$  part not shown.

UN, Pascal Reeck, Vladyslav Shtabovenko, Matthias Steinhauser, *JHEP* 03 (2026) 094

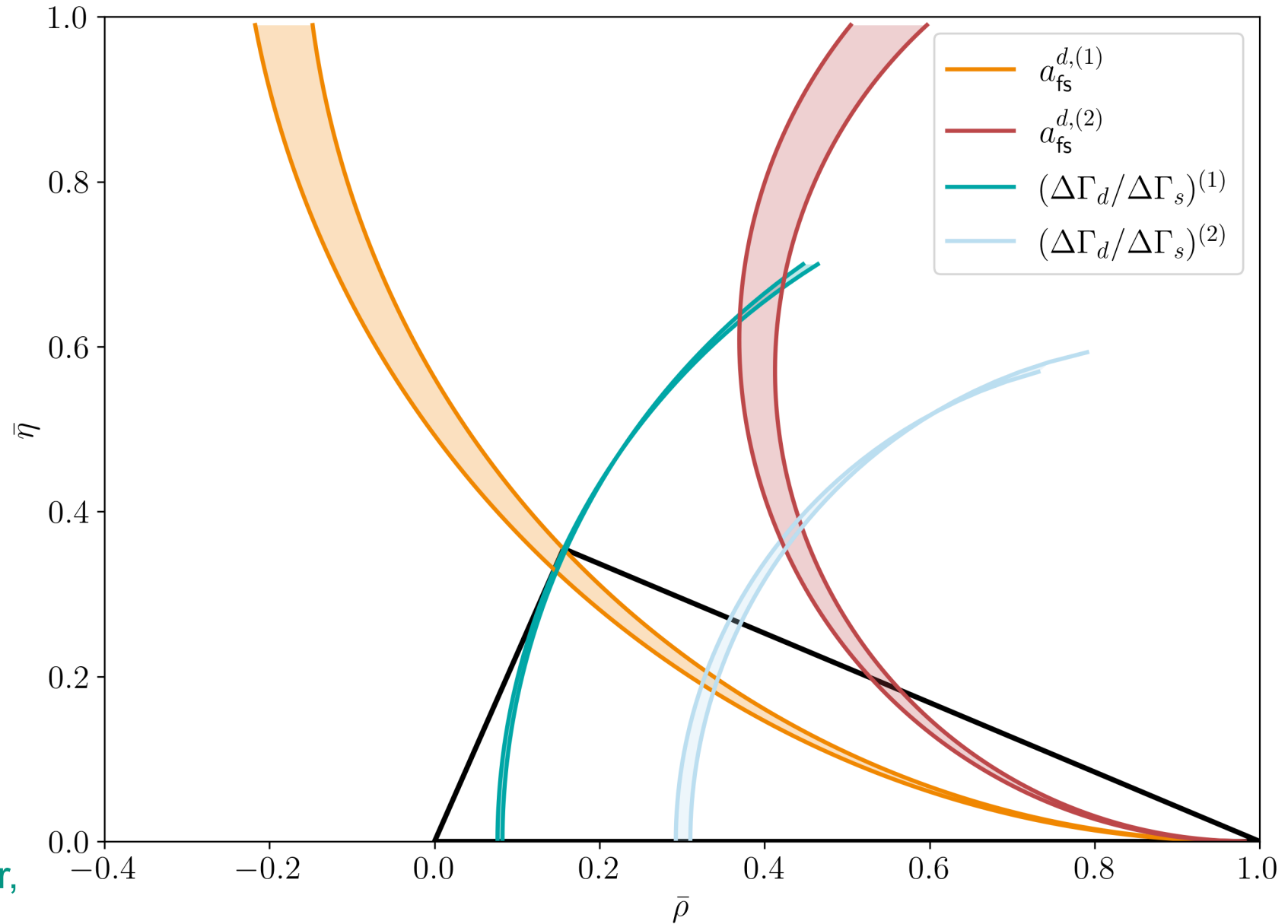

# Conclusions

- The yet unmeasured quantities  $a_{\text{fs}}^{d,s}$  and  $\Delta\Gamma^d$  will complete the knowledge on the  $B_q - \bar{B}_q$  mixing complex and are highly sensitive to new physics.
- The quantities can be calculated reliably. New **NNLO** results were obtained in 2025.
- $a_{\text{fs}}^d$  defines a circle in the  $(\bar{\rho}, \bar{\eta})$  plane!

# The usual theorist's persuasion:



Psst!!! Hey, bud! C'mere.

Who? Me?

You can make a DISCOVERY  
and become famous!  
And it is JUST AROUND  
the corner!

Wow, I can become  
famous!!!

Just look for  $a_{fs}^d$  and  $\Delta\Gamma^d$  !