



The CERN Accelerator School



Introduction to RF Linear Accelerators

Maurizio Vretenar, CERN

Introduction to Accelerator Physics
Granada 2012

1. Why linear accelerators
2. Periodic structures
3. Overview of linacs
4. Linac beam dynamics
5. Bi-periodic structures
6. RFQs
7. Linac Technology



The CERN Accelerator School

Why Linear Accelerators



Linear Accelerators are used for:

1. Low-Energy acceleration (injectors to synchrotrons or stand-alone):
for protons and ions, linacs can be synchronous with the RF fields in the range where velocity increases with energy. When velocity is ~constant, synchrotrons are more efficient (multiple crossings instead of single crossing).
Protons : $\beta = v/c = 0.51$ at 150 MeV, 0.95 at 2 GeV.
2. High-Energy acceleration in the case of:
 - Production of high-intensity proton beams
in comparison with synchrotrons, linacs can go to higher repetition rate, are less affected by resonances and have more distributed beam losses. Higher injection energy from linacs to synchrotrons leads to lower space charge effects in the synchrotron and allows increasing the beam intensity.
 - High energy linear colliders for leptons, where the main advantage is the absence of synchrotron radiation.

2

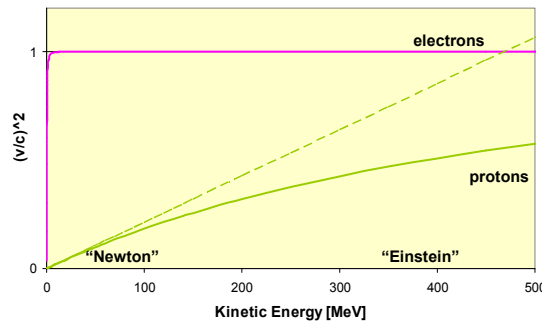

$\beta^2=(v/c)^2$ as function of kinetic energy T for protons and electrons.

Classic (Newton) relation:

$$T = m_0 \frac{v^2}{2}, \quad \frac{v^2}{c^2} = \frac{2T}{m_0 c^2}$$

Relativistic (Einstein) relation:

$$\frac{v^2}{c^2} = 1 - \frac{1}{\sqrt{1 + T/m_0 c^2}}$$

- **Protons** (rest energy 938.3 MeV): follow "Newton" mechanics up to some tens of MeV ($\Delta v/v < 1\%$ for $W < 15$ MeV) then slowly become relativistic ("Einstein"). From the GeV range velocity is nearly constant ($v \sim 0.95c$ at 2 GeV) → linacs can cope with the increasing particle velocity, synchrotrons cover the range where v nearly constant.
- **Electrons** (rest energy 511 keV, 1/1836 of protons): relativistic from the keV range ($v \sim 0.1c$ at 2.5 keV) then increasing velocity up to the MeV range ($v \sim 0.95c$ at 1.1 MeV) → $v \sim c$ after few meters of acceleration (typical gradient 10 MeV/m). 3

The distance between accelerating gaps is proportional to particle velocity

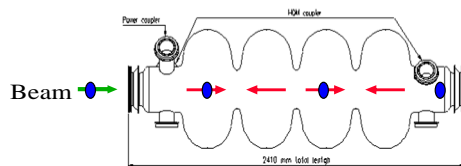

Example: a linac superconducting 4-cell accelerating structure

Synchronism condition bw. particle and wave t (travel between centers of cells) = $T/2$

Electric field (at time t_0)

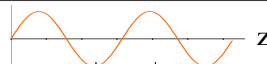

d = distance between centres of consecutive cells

$$\frac{d}{\beta c} = \frac{1}{2f} \Rightarrow d = \frac{\beta c}{2f} = \frac{\beta \lambda}{2}$$

1. In an ion linac cell length has to increase (up to a factor 200 !) and the linac will be made of a sequence of different accelerating structures (changing cell length, frequency, operating mode, etc.) matched to the ion velocity.
2. For electron linacs, $\beta=1$, $d=\lambda/2$ → An electron linac will be made of an injector + a series of identical accelerating structures, with cells all the same length

Note that in the example above, we neglect the increase in particle velocity inside the cavity ! 4

Linear and circular accelerators

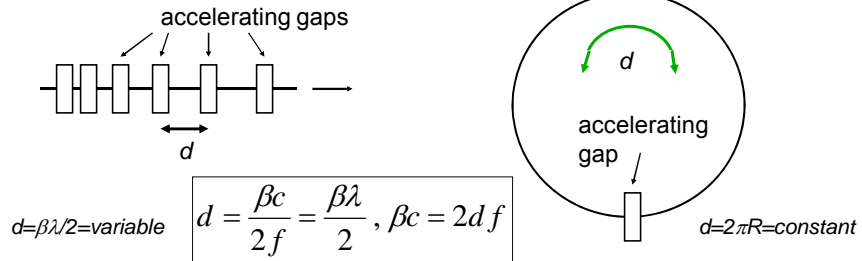

Linear accelerator:

Particles accelerated by a sequence of gaps (all at the same RF phase).

Distance between gaps increases proportionally to the particle velocity, to keep synchronicity.

Used in the range where β increases. "Newton" machine

Circular accelerator:

Particles accelerated by one (or more) gaps at given positions in the ring.

Distance between gaps is fixed. Synchronicity only for $\beta \sim \text{const}$, or varying (in a limited range!) the RF frequency.

Used in the range where β is nearly constant. "Einstein" machine

Example 1: gap spacing in a Drift Tube Linac (low β)

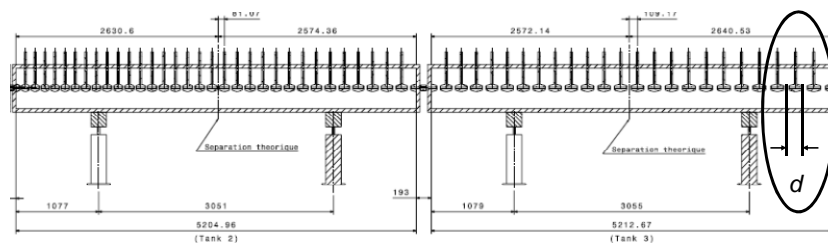

Tank 2 and 3 of the new Linac4 at CERN:

Beam energy from 10 to 50 MeV

Beta from 0.145 to 0.31

Cell length from 12.3 cm to 26.4 cm (factor 2!)

This arrangement works only for one type of particles and one range of energies!

The same superconducting cavity design can be used for different proton velocities. The linac has different sections, each made of cavities with cell length matched to the average beta in that section. At "medium energy" (>150 MeV) we are not obliged to dimension every cell or every cavity for the particular particle beta at that position, and we can accept a slight "asynchronicity".

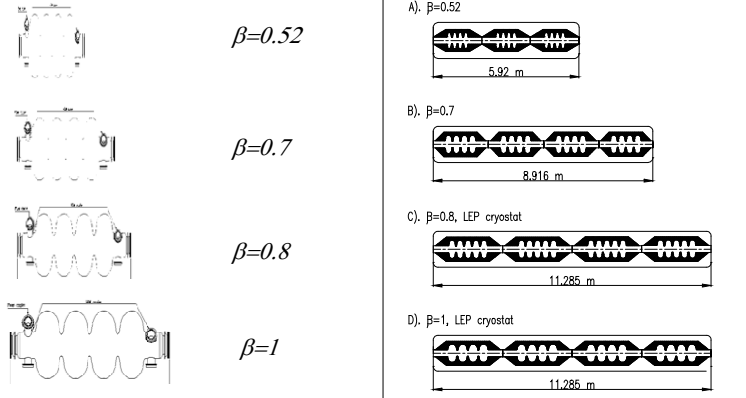

CERN (old) SPL design, SC linac 120 - 2200 MeV, 680 m length, 230 cavities

2 - Acceleration in Periodic Structures

Wave propagation in a cylindrical pipe

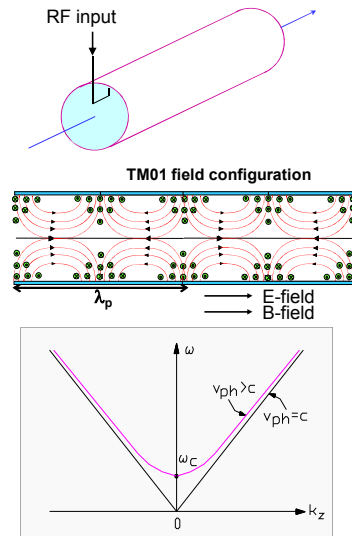

- > In a cylindrical waveguide different modes can propagate (=Electromagnetic field distributions, transmitting power and/or information). The field is the superposition of waves reflected by the metallic walls of the pipe → velocity and wavelength of the modes will be different from free space (c, λ)
- > To accelerate particles, we need a mode with longitudinal E-field component on axis: a TM mode (Transverse Magnetic, $B_z=0$). The simplest is TM01.
- > We inject RF power at a frequency exciting the TM01 mode: sinusoidal E-field on axis, wavelength λ_p depending on frequency and on cylinder radius. Wave velocity (called "phase velocity") is $v_{ph} = \lambda_p / T = \lambda_p f = \omega / k_z$ with $k_z = 2\pi / \lambda_p$
- > The relation between frequency ω and propagation constant k is the DISPERSION RELATION (red curve on plot), a fundamental property of waveguides.

9

Wave velocity: the dispersion relation

The dispersion relation $\omega(k)$ can be calculated from the theory of waveguides:
 $\omega^2 = k^2 c^2 + \omega_c^2$ Plotting this curve (hyperbola), we see that:

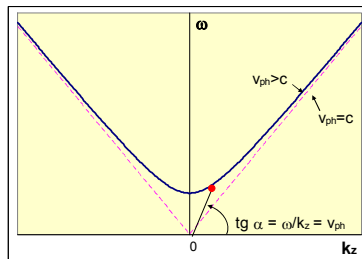

$$k = 2\pi / \lambda_p$$

$$v_{ph} = \omega / k = (c^2 + \omega_c^2 / k^2)^{1/2}$$

$$v_g = d\omega / dk$$

- 1) There is a "cut-off frequency", below which a wave will not propagate. It depends on dimensions ($\lambda_c = 2.61a$ for the cylindrical waveguide).
- 2) At each excitation frequency is associated a phase velocity, the velocity at which a certain phase travels in the waveguide. $v_p = \infty$ at $k=0$, $\omega = \omega_c$ and then decreases towards $v_p = c$ for $k, \omega \rightarrow \infty$.
- 3) To see at all times an accelerating E-field a particle traveling inside our cylinder has to travel at $v = v_{ph} \rightarrow v > c$!!!

Are we violating relativity? No, energy (and information) travel at group velocity $d\omega / dk$, always between 0 and c .

To use the waveguide to accelerate particles, we need a "trick" to slow down the wave.

Slowing down waves: the disc-loaded waveguide

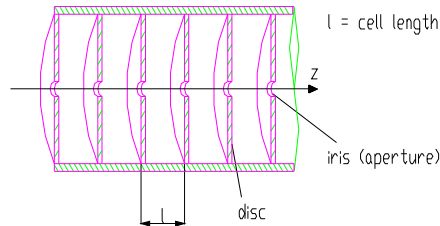

Discs inside the cylindrical waveguide, spaced by a distance l , will induce multiple reflections between the discs.

11

Dispersion relation for the disc-loaded waveguide

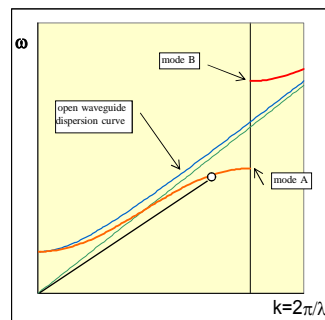
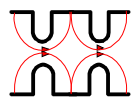
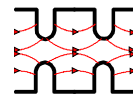
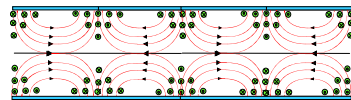

➤ Wavelengths with $\lambda_p/2 \sim l$ will be most affected by the discs. On the contrary, for $\lambda_p=0$ and $\lambda_p=\infty$ the wave does not see the discs → the dispersion curve remains that of the empty cylinder.

➤ At $\lambda_p/2 = l$, the wave will be confined between the discs, and present 2 "polarizations" (mode A and B in the figure), 2 modes with same wavelength but different frequencies → the dispersion curve splits into 2 branches, separated by a stop band.

➤ In the disc-loaded waveguide, the lower branch of the dispersion curve is now "distorted" in such a way that we can find a range of frequencies with $v_{ph} = c$ → we can use it to accelerate a particle beam!

➤ We have built a linac for $v \sim c$ → a TRAVELING WAVE (TW) ELECTRON LINAC

12

Traveling wave linac structures

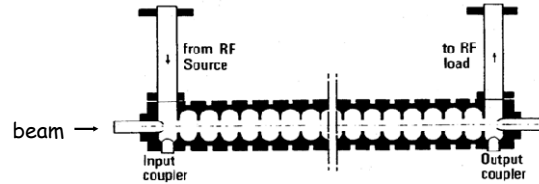

- Disc-loaded waveguide designed for $v_{ph}=c$ at a given frequency, equipped with an input and an output coupler.
- RF power is introduced via the input coupler. Part of the power is dissipated in the structure, part is taken by the beam (beam loading) and the rest is absorbed in a matched load at the end of the structure. Usually, structure length is such that $\sim 30\%$ of power goes to the load.
- The "traveling wave" structure is the standard linac for electrons from $\beta \sim 1$.
- Can not be used for protons at $v < c$:
 1. constant cell length does not allow synchronism
 2. structures are long, without space for transverse focusing

13

Standing wave linac structures

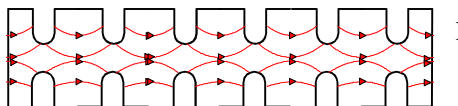

To obtain an accelerating structure for protons we close our disc-loaded structure at both ends with metallic walls → multiple reflections of the waves.

Boundary condition at both ends is that electric field must be perpendicular to the cover → Only some modes on the disc-loaded dispersion curve are allowed → only some frequencies on the dispersion curve are permitted.

In general:

1. the modes allowed will be equally spaced in k
2. The number of modes will be identical to the number of cells (N cells → N modes)
3. k represents the phase difference between the field in adjacent cells.

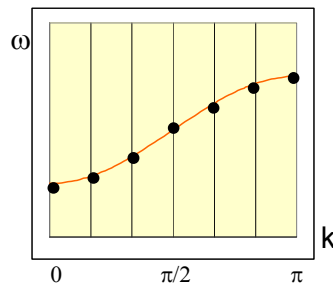

14

More on standing wave structures

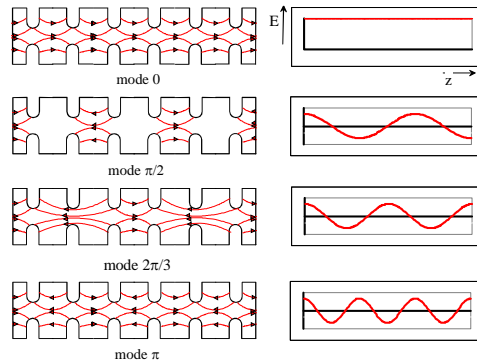

Standing wave modes are named from the phase difference between adjacent cells: in the example above, mode 0, $\pi/2$, $2\pi/3$, π .

In standing wave structures, cell length can be matched to the particle velocity!

→ STANDING WAVE MODES are generated by the sum of 2 waves traveling in opposite directions, adding up in the different cells.

→ For acceleration, the particles must be in phase with the E-field on axis. We have already seen the π mode: synchronism condition for cell length $l = \beta\lambda/2$.

→ Standing wave structures can be used for any β (→ ions and electrons) and their cell length can increase, to follow the increase in β of the ions.

Synchronism conditions:

0-mode : $l = \beta\lambda$

$\pi/2$ mode: $2l = \beta\lambda/2$

π mode: $l = \beta\lambda/2$

15

Acceleration on traveling and standing waves

TRAVELING Wave

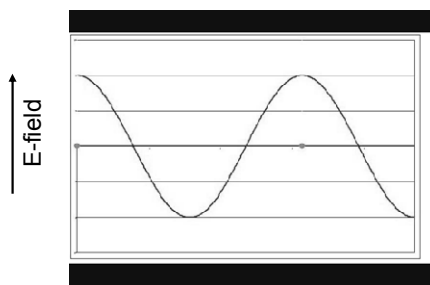

→ position z

STANDING Wave

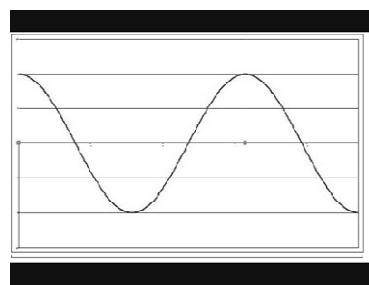

→ position z

16

Practical standing wave structures

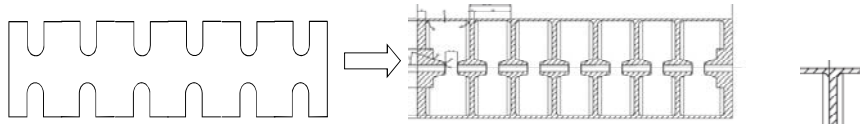

From disc-loaded structure to a real cavity (Linac4 PIMS, Pi-Mode Structure)

1. To increase acceleration efficiency (=shunt impedance ZT^2 !) we need to concentrate electric field on axis ($Z \uparrow$) and to shorten the gap ($T \uparrow$) → introduction of "noses" on the openings.
2. The smaller opening would not allow the wave to propagate → introduction of "coupling slots" between cells.
3. The RF wave has to be coupled into the cavity from one point, usually in the center.

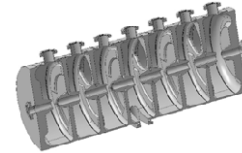

Comparing traveling and standing wave structures

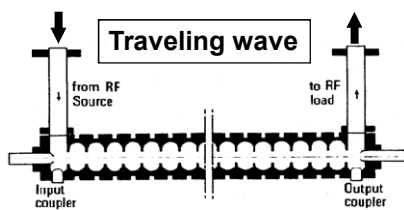

Chain of coupled cells in TW mode
Coupling bw. cells from on-axis aperture.
RF power from input coupler at one end, dissipated in the structure and on a load.

Short pulses, High frequency (≥ 3 GHz).
Gradients 10-20 MeV/m

Used for Electrons at $v \sim c$

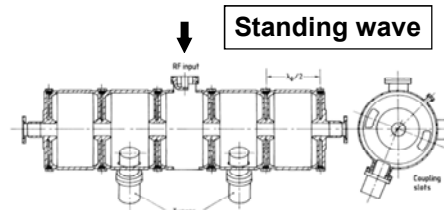

Chain of coupled cells in SW mode.
Coupling (bw. cells) by slots (or open). On-axis aperture reduced, higher E-field on axis and power efficiency.
RF power from a coupling port, dissipated in the structure (ohmic loss on walls).

Long pulses. Gradients 2-5 MeV/m

Used for Ions and electrons, all energies

Comparable RF efficiencies

3 - Examples of linac accelerating structures:

- a. protons,
- b. electrons,
- c. heavy ions

The Drift Tube Linac (also called "Alvarez")

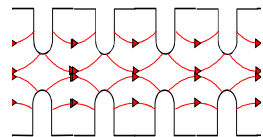

Disc-loaded structures operating in 0-mode

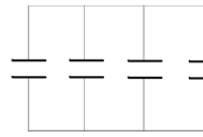

Add tubes for high shunt impedance

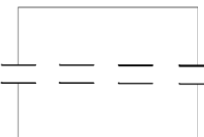

Maximize coupling between cells → remove completely the walls

2 advantages of the 0-mode:

1. the fields are such that if we eliminate the walls between cells the fields are not affected, but we have less RF currents and higher shunt impedance.
2. The "drift tubes" can be long ($\sim 0.75 \beta \lambda$), the particles are inside the tubes when the electric field is decelerating, and we have space to introduce focusing elements (quadrupoles) inside the tubes.

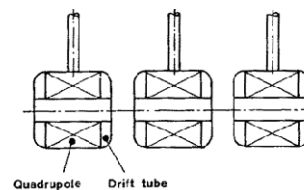

More on the DTL

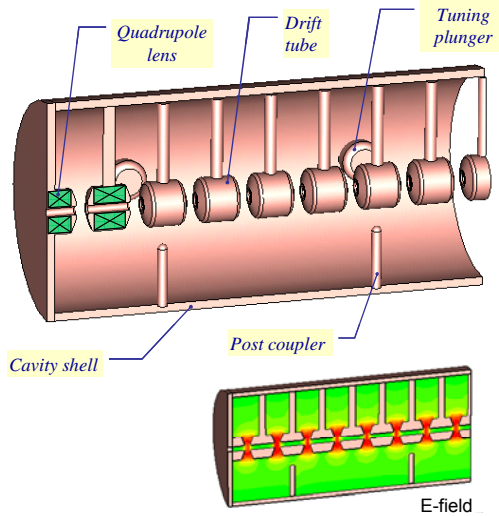

Standing wave linac structure for protons and ions,
 $\beta=0.1-0.5$, $f=20-400$ MHz
 Chain of coupled cells, completely open (no walls), maximum coupling.
 Operating in 0-mode, cell length $\beta\lambda$.
 Drift tubes are suspended by stems (no net current)
 Drift tubes contain focusing quadrupoles.

21

Examples of DTL

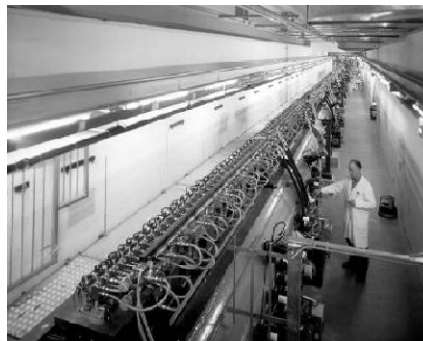
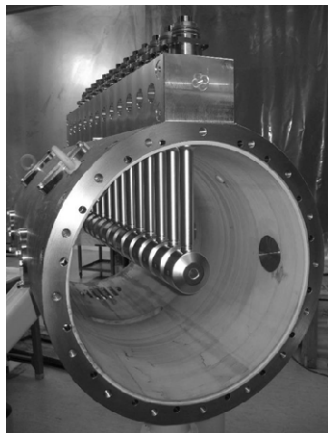

Top: CERN Linac2 Drift Tube Linac accelerating tank 1 (200 MHz). The tank is 7m long (diameter 1m) and provides an energy gain of 10 MeV.
 Left: DTL prototype for CERN Linac4 (352 MHz). Focusing is provided by (small) quadrupoles inside drift tubes. Length of drift tubes (cell length) increases with proton velocity.

22

Example: the Linac4 DTL

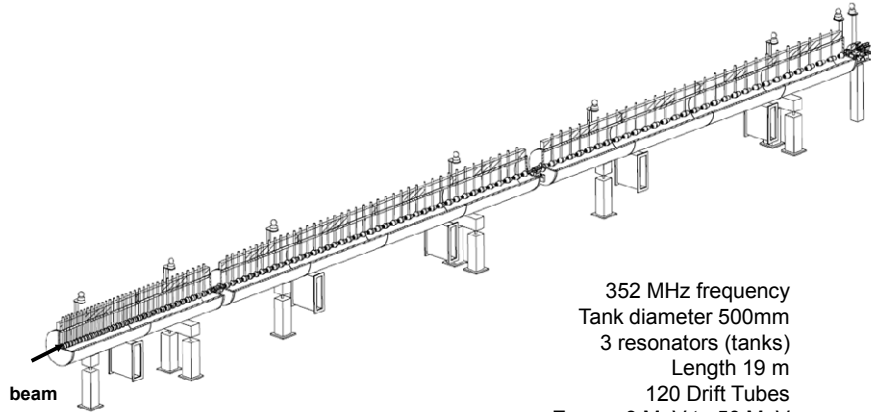

352 MHz frequency
 Tank diameter 500mm
 3 resonators (tanks)
 Length 19 m
 120 Drift Tubes
 Energy 3 MeV to 50 MeV
 Beta 0.08 to 0.31 → cell length ($\beta\lambda$) 68mm to 264mm
 → factor 3.9 increase in cell length

23

Multigap linac structures: the PI Mode Structure

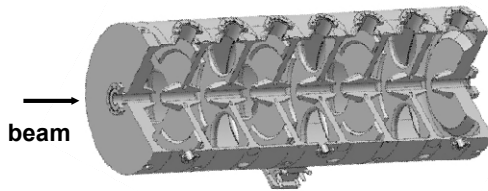

PIMS=PI Mode Structure
 Standing wave linac structure for
 protons, $\beta > 0.4$
 Frequency 352 MHz
 Chain of coupled cells with coupling
 slots in walls.
 Operating in π -mode, cell length
 $\beta\lambda/2$.

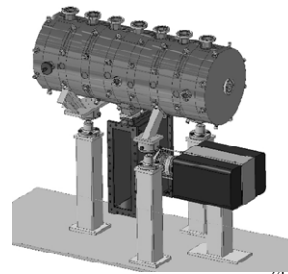
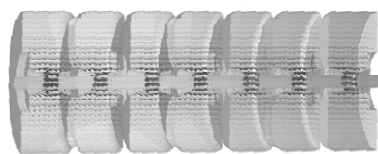

24

Sequence of PIMS cavities

Cells have same length inside a cavity (7 cells) but increase from one cavity to the next. At high energy (>100 MeV) beta changes slowly and phase error ("phase slippage") is small.

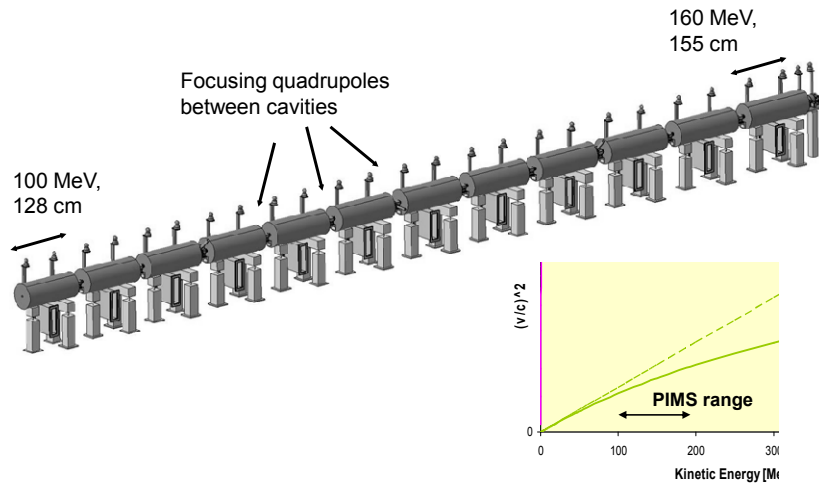

Proton linac architecture - cell length, focusing period

EXAMPLE: the Linac4 project at CERN. H-, 160 MeV energy, 352 MHz. A 3 MeV injector + 22 multi-cell standing wave accelerating structures of 3 types

- DTL:** every cell is different, focusing quadrupoles in each drift tube
- CCDTL:** sequences of 2 identical cells, quadrupoles every 3 cells
- PIMS:** sequences of 7 identical cells, quadrupoles every 7 cells

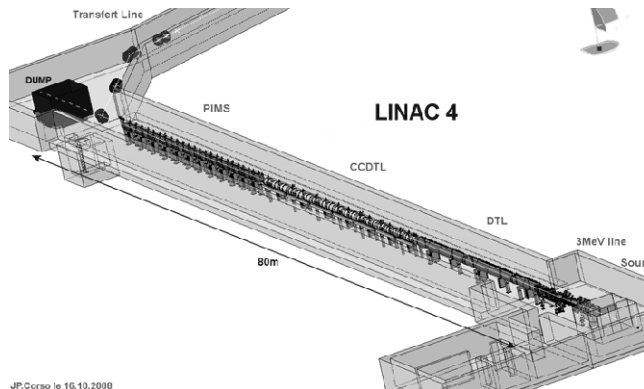

Two basic principles to remember:

1. As beta increases, phase error between cells of identical length becomes small → we can have short sequences of identical cells (lower construction costs).
2. As beta increases, the distance between focusing elements can increase (more details in 2nd lecture!).

Proton linac architecture - Shunt impedance

A third basic principle:
Every proton linac structure has a characteristic curve of shunt impedance (=acceleration efficiency) as function of energy, which depends on the mode of operation.

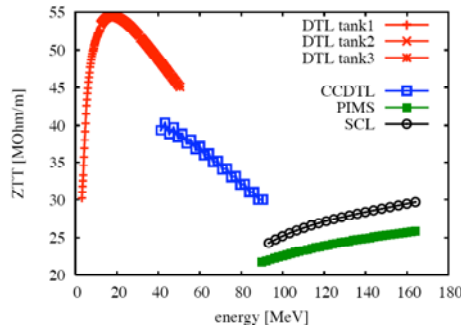

3MeV	50MeV	100MeV	160MeV
DTL	CCDTL	PIMS	
Drift Tube Linac	Cell-Coupled Drift Tube Linac	Pi-Mode Structure	
18.7 m 3 tanks 3 klystrons	25 m 7 tanks 7 klystrons	22 m 12 tanks 8 klystrons	

The choice of the best accelerating structure for a certain energy range depends on shunt impedance, but also on beam dynamics and construction cost.

$$ZT^2 = \frac{V_{eff}^2}{P} = \frac{(E_0 T)^2}{P}$$

$$\Delta W = eE_0 T \cos \varphi$$

Effective shunt impedance ZT^2 is the ratio between voltage seen by the beam and power (for a given gap)

Multi-gap Superconducting linac structures (elliptical)

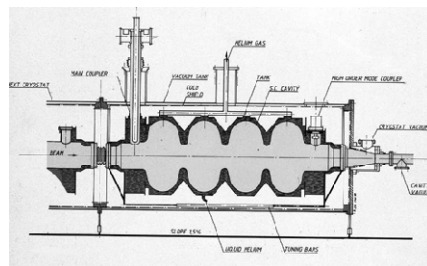
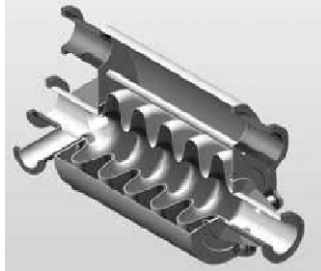

Standing wave structures for particles at $\beta > 0.5-0.7$, widely used for protons (SNS, etc.) and electrons (ILC, etc.)
 $f=350-700$ MHz (protons),
 $f=350$ MHz - 3 GHz (electrons)
 Chain of cells electrically coupled, large apertures (ZT^2 not a concern).

Operating in π -mode, cell length $\beta\lambda/2$
 Input coupler placed at one end.



Other superconducting structures for linacs

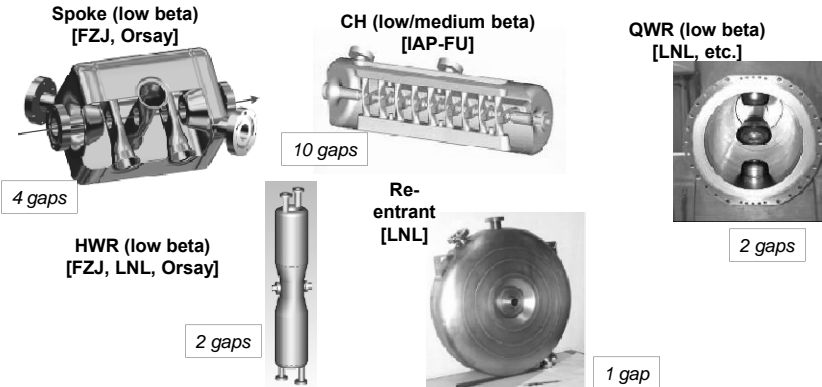

Superconducting linacs for low and medium beta ions are made of multi-gap (1 to 4) individual cavities, spaced by focusing elements. Advantages: can be individually phased → linac can accept different ions
Allow more space for focusing → ideal for low β CW proton linacs

29

Quarter Wave Resonators

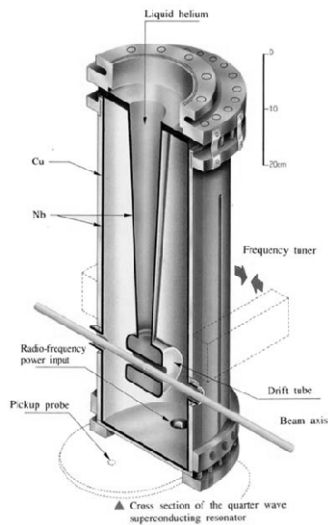

Simple 2-gap cavities commonly used in their superconducting version (lead, niobium, sputtered niobium) for low beta protons or ion linacs, where ~CW operation is required.

Synchronicity (distance $\beta\lambda/2$ between the 2 gaps) is guaranteed only for one energy/velocity, while for easiness of construction a linac is composed by series of identical QWR's → reduction of energy gain for "off-energy" cavities, Transit Time Factor curves as below: "phase slippage"

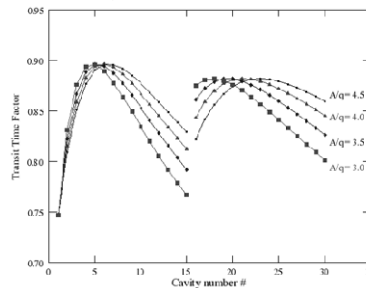

$$T = \frac{V_{eff}}{V_0}$$

Transit time factor T is the ratio between voltage seen by the beam (because of finite velocity) and actual voltage in the gap

30

H-mode structures

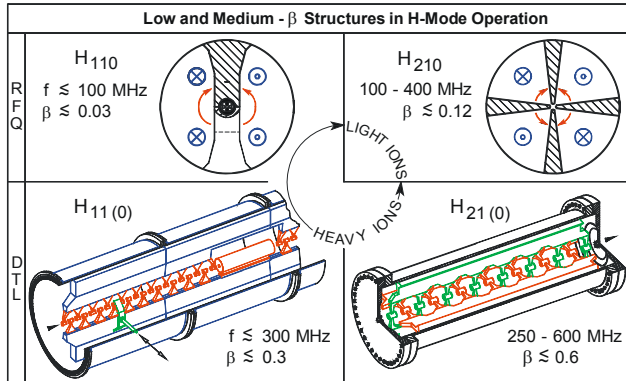

Interdigital-H Structure Operates in TE₁₁₀ mode
 Transverse E-field "deflected" by adding drift tubes
 Used for ions, $\beta < 0.3$

CH Structure operates in TE₂₁₀, used for protons at $\beta < 0.6$

High ZT^2 but more difficult beam dynamics (no space for quads in drift tubes)

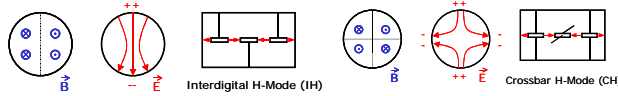

HSI - IH DTL, 36 MHz



Examples: an electron linac

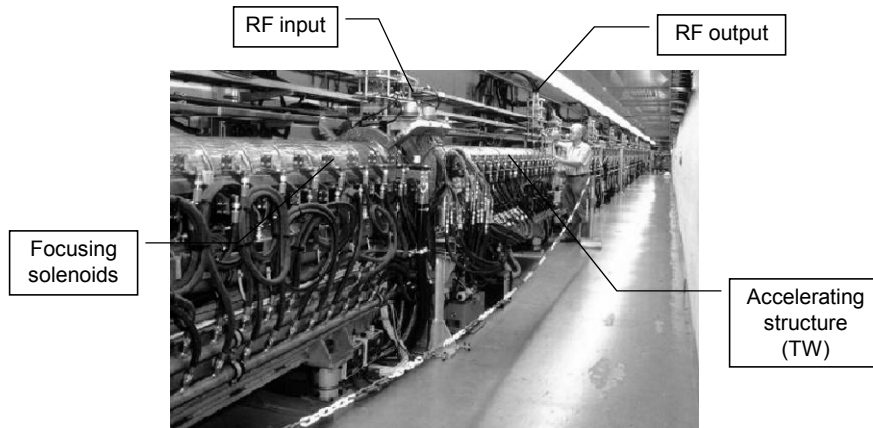

The old CERN LIL (LEP Injector Linac) accelerating structures (3 GHz). The TW structure is surrounded by focusing solenoids, required for the positrons.

Examples: a TW accelerating structure

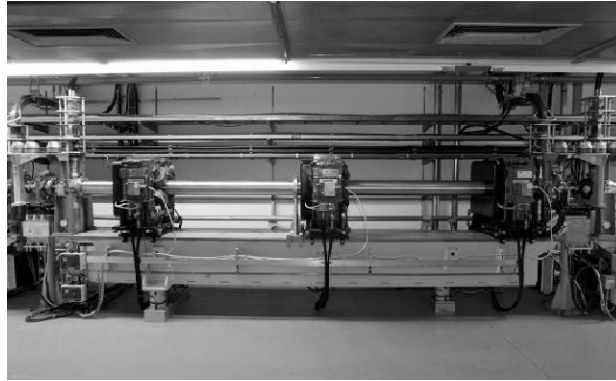

A 3 GHz LIL accelerating structure used for CTF3. It is 4.5 meters long and provides an energy gain of 45 MeV. One can see 3 quadrupoles around the RF structure.

33

Electron linac architecture

EXAMPLE: the CLIC Test facility (CTF) at CERN: drive linac, 3 GHz, 184 MeV.
 An injector + a sequence of 20 identical multi-cell traveling wave accelerating structures.
 Main beam accelerator: 8 identical accelerating structures at 30 GHz, 150-510 MeV

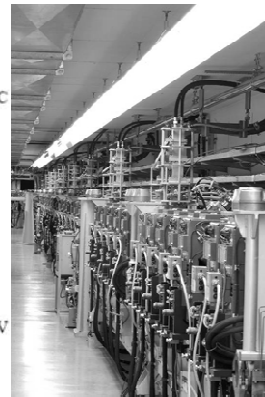
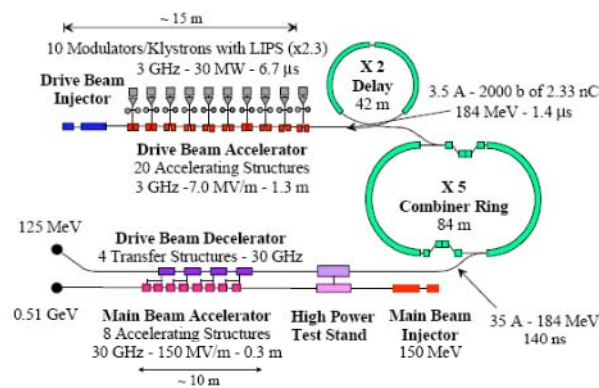

34

EXAMPLE: the REX upgrade project at CERN-ISOLDE. Post-acceleration of radioactive ions with different A/q up to energy in the range 2-10 MeV. An injector (source, charge breeder, RFQ) + a sequence of short (few gaps) standing wave accelerating structures at frequency 101-202 MHz, normal conducting at low energy (Interdigital, IH) and superconducting (Quarter Wave Resonators) at high energy → mix of NC-SC, different structures, different frequencies.

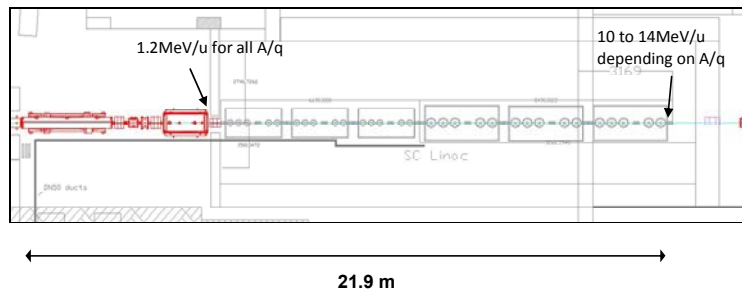

35

Particle source

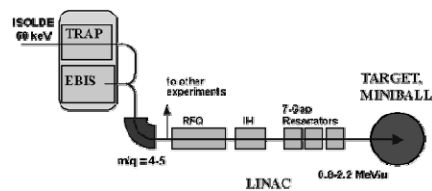
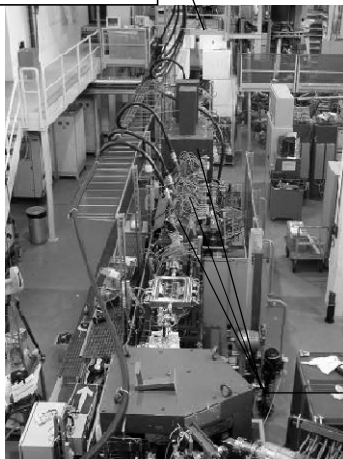

The REX heavy-ion post accelerators at CERN. It is made of 5 short standing wave accelerating structures at 100 MHz, spaced by focusing elements.

Accelerating structures

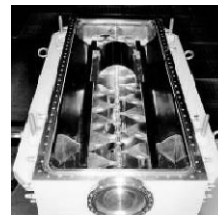

36

4 - Beam Dynamics of Ion and Electron Linacs

37

Longitudinal dynamics

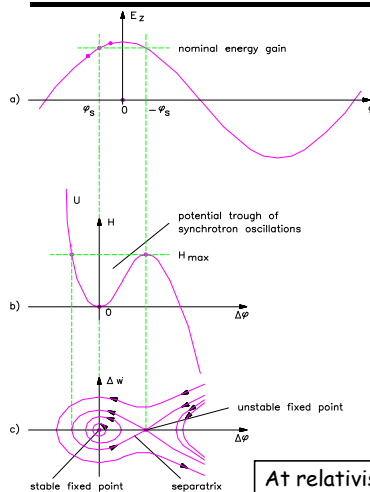

→ Ions are accelerated around a (negative = linac definition) synchronous phase.

→ Particles around the synchronous one perform oscillations in the longitudinal phase space.

→ Frequency of small oscillations:

$$\omega_1^2 = \omega_0^2 \frac{qE_0 T \sin(-\varphi) \lambda}{2\pi mc^2 \beta \gamma^3}$$

→ Tends to zero for relativistic particles $\gamma \gg 1$.

→ Note phase damping of oscillations:

$$\Delta\varphi = \frac{\text{const}}{(\beta \gamma)^{3/4}} \quad \Delta W = \text{const} \times (\beta \gamma)^{3/4}$$

At relativistic velocities phase oscillations stop, and the beam is compressed in phase around the initial phase. The crest of the wave can be used for acceleration.

38

- Electrons at $v=c$ remain at the injection phase.
- Electrons at $v < c$ injected into a TW structure designed for $v=c$ will move from injection phase φ_0 to an asymptotic phase φ , which depends only on gradient and β_0 at injection.
- The beam can be injected with an offset in phase, to reach the crest of the wave at $\beta=1$
- Capture condition, relating E_0 and β_0 :

$$\frac{2\pi mc^2}{\lambda_g qE_0} \left[\sqrt{\frac{1-\beta_0}{1+\beta_0}} \right] = 1$$

Example: $\lambda=10\text{cm}$, $W_{in}=150\text{ keV}$ and $E_0=8\text{ MV/m}$.

$$\sin \varphi = \sin \varphi_0 + \frac{2\pi mc^2}{\lambda_g qE_0} \left[\sqrt{\frac{1-\beta_0}{1+\beta_0}} - \sqrt{\frac{1-\beta}{1+\beta}} \right]$$

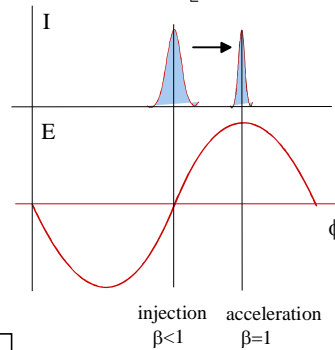

In high current linacs, a bunching and pre-acceleration sections up to 4-10 MeV prepares the injection in the TW structure (that occurs already on the crest)

39

- Large numbers of particles per bunch ($\sim 10^{10}$).
- Coulomb repulsion between particles (space charge) plays an important role.
- But space charge forces $\sim 1/\gamma^2$ disappear at relativistic velocity: the magnetic attraction compensates exactly for the coulomb repulsion!

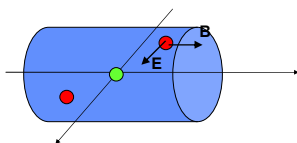

Force on a particle inside a long bunch with density $n(r)$ traveling at velocity v :

$$E_r = \frac{e}{2\pi\epsilon r} \int_0^r n(r) r dr \quad B_\phi = \frac{\mu}{2\pi} \frac{ev}{r} \int_0^r n(r) r dr$$

$$F = e(E_r - vB_\phi) = eE_r \left(1 - \frac{v^2}{c^2}\right) = eE_r (1 - \beta^2) = \frac{eE_r}{\gamma^2}$$

Note that the expression for space charge forces in a bunch can be vary complicated (and linac beam dynamics in the space charge regime is a science in itself!)

40

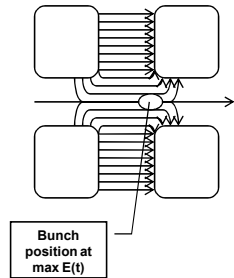

- RF defocusing experienced by particles crossing a gap on a longitudinally stable phase.
- In the rest frame of the particle, only electrostatic forces → no stable points (maximum or minimum) → radial defocusing.
- Lorentz transformation and calculation of radial momentum impulse per period (from electric and magnetic field contribution in the laboratory frame):

$$\Delta p_r = -\frac{\pi e E_0 T L r \sin \varphi}{c \beta^2 \gamma^2 \lambda}$$

- Transverse defocusing $\sim 1/\gamma^2$ disappears at relativistic velocity (transverse magnetic force cancels the transverse RF electric force).
- Important consequence: in an electron linac, transverse and longitudinal dynamics are decoupled !

41

Defocusing forces need to be compensated by focusing forces → alternating gradient focusing provided by quadrupoles along the beam line.

A linac alternates accelerating sections with focusing sections. Options are: one quadrupole (singlet focusing), two quadrupoles (doublet focusing) or three quadrupoles (triplet focusing).

Focusing period=length after which the structure is repeated (usually as $N\beta\lambda$).

The accelerating sections have to match the increasing beam velocity → the basic focusing period increases in length (but the beam travel time in a focusing period remains constant). The maximum allowed distance between focusing elements depends on beam energy and current and change in the different linac sections (from only one gap in the DTL to one or more multi-cell cavities at high energies).

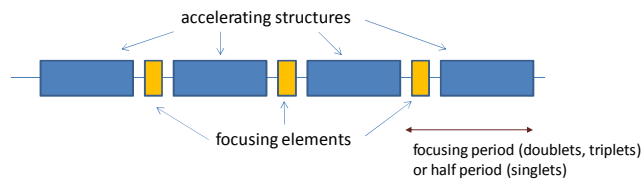

42

The equilibrium between external focusing force and internal defocusing forces defines the frequency of beam oscillations.

Oscillations are characterized in terms of *phase advance per focusing period* σ_r , or *phase advance per unit length* k_r .

Ph. advance = Ext. quad focusing - RF defocusing - space charge - Instabilities

$$k_r^2 = \left(\frac{\sigma_r}{N\beta\lambda} \right)^2 = \left(\frac{qGl}{2mc\beta\gamma} \right)^2 - \frac{\pi q E_0 T \sin(-\phi)}{mc^2 \lambda \beta^3 \gamma^3} - \frac{3qI\lambda(1-f)}{8\pi\epsilon_0 r_0^3 mc^3 \beta^2 \gamma^3} - \dots$$

Approximate expression valid for:
 FODO lattice, smooth focusing approximation, space charge of a uniform 3D ellipsoidal bunch.
 G =quadrupole gradient, ϕ =synchronous phase, I =beam current, f =bunch form factor, r_0 =average beam radius

Electron Linac:

Ph. advance = Ext. focusing + RF defocusing + ~~space charge~~ + Instabilities

For $\gamma \gg 1$ (electron linac): RF defocusing and space charge disappear, *phase advance* $\rightarrow 0$.

External focusing is required only to control the emittance and to stabilize the beam against instabilities (as wakefields and beam breakup).

43

Focusing provided by quadrupoles (but solenoids for low β !).

Different distance between focusing elements (=1/2 length of a FODO focusing period)! For the main linac accelerating structure (after injector):

Protons, (high beam current and high space charge) require short distances:

- $\beta\lambda$ in the DTL, from ~70mm (3 MeV, 352 MHz) to ~250mm (40 MeV),
- can be increased to 4-10 $\beta\lambda$ at higher energy (>40 MeV).
- longer focusing periods require special dynamics (example: the IH linac).

Heavy ions (low current, no space charge):

2-10 $\beta\lambda$ in the main linac (>~150mm).

Electrons (no space charge, no RF defocusing):

up to several meters, depending on the required beam conditions. Focusing is mainly required to control the emittance.

44

Transverse (x) r.m.s. beam envelope along Linac4

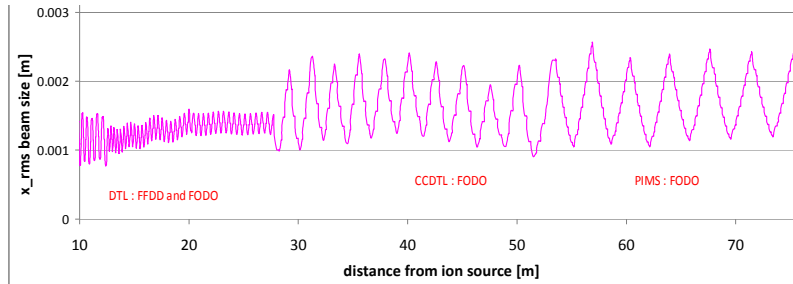

Example: beam dynamics design for Linac4@CERN.

High intensity protons (60 mA bunch current, duty cycle could go up to 5%), 3 - 160 MeV

Beam dynamics design minimising emittance growth and halo development in order to:

1. avoid uncontrolled beam loss (activation of machine parts)
2. preserve small emittance (high luminosity in the following accelerators)

45

Prescriptions to minimise emittance growth:

1. Keep zero current phase advance always below 90° , to avoid resonances
2. Keep longitudinal to transverse phase advance ratio 0.5-0.8, to avoid emittance exchange
3. Keep a smooth variation of transverse and longitudinal phase advance per meter.
4. Keep sufficient safety margin between beam radius and aperture

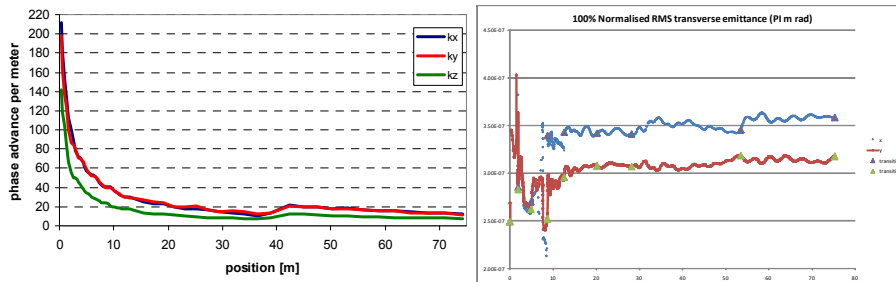

Transverse r.m.s. emittance and phase advance along Linac4 (RFQ-DTL-CCDTL-PIMS)

46

5. Double periodic accelerating structures

47

Long chains of linac cells

- ☞ To reduce RF cost, linacs use high-power RF sources feeding a large number of coupled cells (DTL: 30-40 cells, other high-frequency structures can have >100 cells).
- ☞ Long linac structures operating in the 0 or π modes are extremely sensitive to mechanical errors: small machining errors in the cells can induce large differences in the accelerating field between cells.

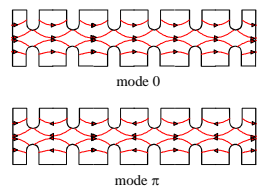
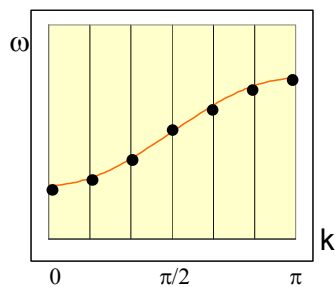

48

Stability of long chains of coupled resonators

Mechanical errors → differences in frequency between cells → to respect the new boundary conditions the electric field will be a linear combination of all modes, with weight

$$\frac{1}{f^2 - f_0^2}$$

(general case of small perturbation to an eigenmode system, the new solution is a linear combination of all the individual modes)

The nearest modes have the highest effect, and when there are many modes on the dispersion curve (number of modes = number of cells !) the difference in E-field between cells can be extremely high.

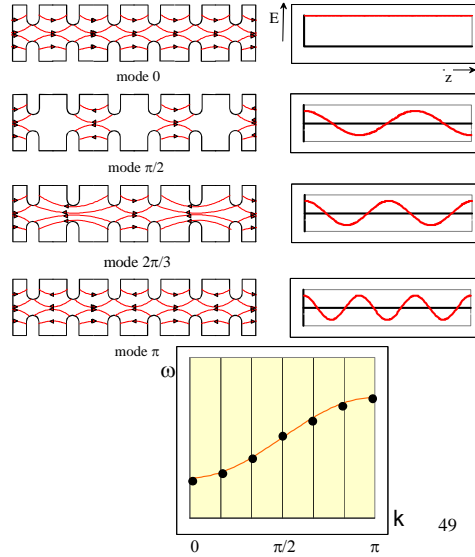

Stabilization of long chains: the π/2 mode

Solution:
Long chains of linac cells are operated in the π/2 mode, which is intrinsically insensitive to differences in the cell frequencies.

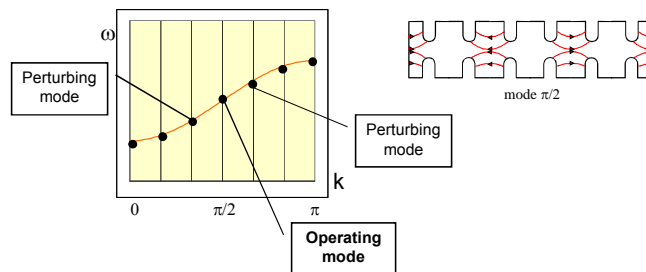

Contribution from adjacent modes proportional to $\frac{1}{f^2 - f_0^2}$ with the sign !!!

Contribution from equally spaced modes in the dispersion curve will cancel each other.

The Side Coupled Linac

To operate efficiently in the $\pi/2$ mode, the cells that are not excited can be removed from the beam axis \rightarrow they become coupling cells, as for the Side Coupled Structure.

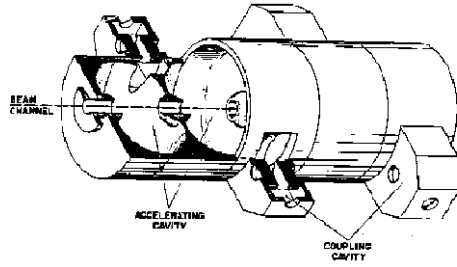

multi-cell Standing Wave structure in $\pi/2$ mode
frequency 800 - 3000 MHz
for protons ($\beta=0.5 - 1$)

Example: the Cell-Coupled Linac at SNS, >100 cells/module



Examples of $\pi/2$ structures

$\pi/2$ -mode in a coupled-cell structure

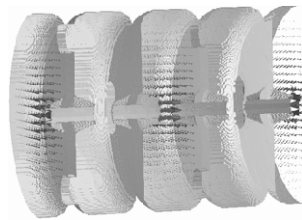

On axis Coupled Structure (OCS)

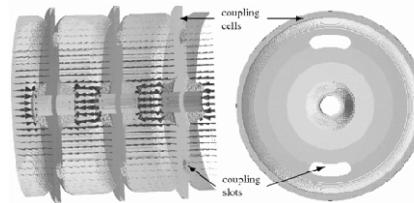

Annular ring Coupled Structure (ACS)

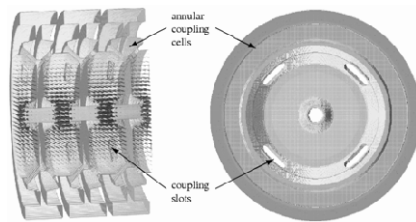

Side Coupled Structure (SCS)

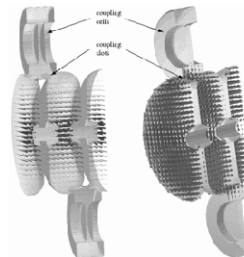

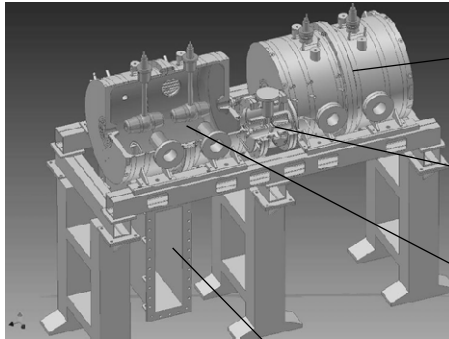

DTL-like tank
(2 drift tubes)

Coupling cell

DTL-like tank
(2 drift tubes)

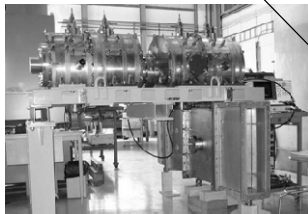

Waveguide
input coupler

Series of DTL-like tanks (0-mode), coupled by coupling cells ($\pi/2$ mode)

352 MHz, will be used for the CERN Linac4 in the range 40-100 MeV.

Quadrupoles between tanks \rightarrow easier alignment, lower cost than standard DTL

6. The Radio Frequency Quadrupole

At low proton (or ion) energies, space charge defocusing is high and quadrupole focusing is not very effective, cell length becomes small → conventional accelerating structures (Drift Tube Linac) are very inefficient → use a (relatively) new structure, the Radio Frequency Quadrupole.

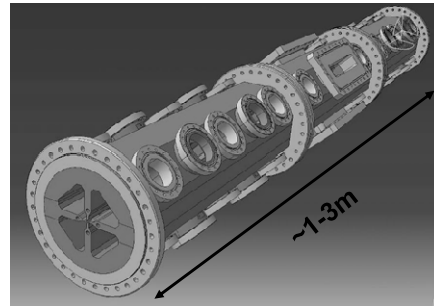
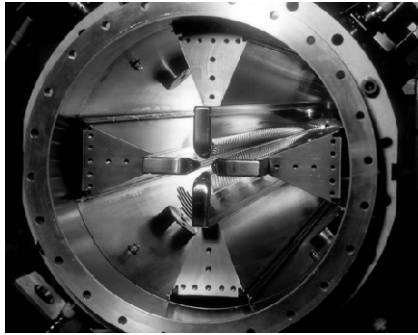

RFQ = Electric quadrupole focusing channel + bunching + acceleration

55

- Four electrodes (vanes) between which we excite an RF Quadrupole mode (TE₂₁₀) → Electric focusing channel, alternating gradient with the period of the RF. Note that electric focusing does not depend on the velocity (ideal at low β !)
- The vanes have a longitudinal modulation with period = $\beta\lambda$ → this creates a longitudinal component of the electric field. The modulation corresponds exactly to a series of RF gaps and can provide acceleration.

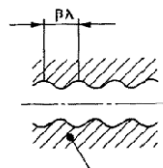
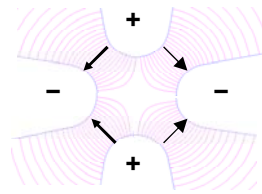

Opposite vanes (180°)

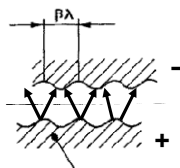

Adjacent vanes (90°)

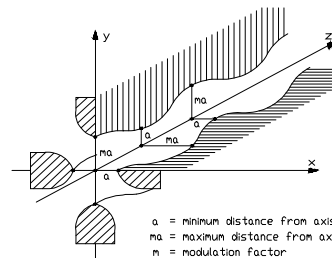

56

3. The modulation period (distance between maxima) can be slightly adjusted to change the phase of the beam inside the RFQ cells, and the amplitude of the modulation can be changed to change the accelerating gradient → we can start at -90° phase (linac) with some bunching cells, progressively bunch the beam (adiabatic bunching channel), and only in the last cells switch on the acceleration.

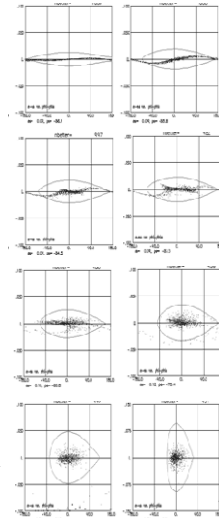

☞ An RFQ has 3 basic functions:

1. Adiabatically bunching of the beam.
2. Focusing, on electric quadrupole.
3. Accelerating.

Longitudinal beam profile of a proton beam along the CERN RFQ2: from a continuous beam to a bunched accelerated beam in 300 cells. →

57

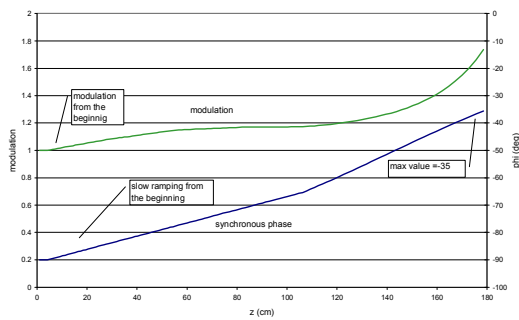

CERN High intensity RFQ (RFQ2, 200 mA, 1.8m length)

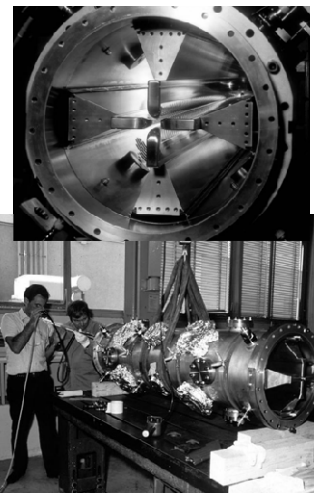

58

How to create a quadrupole RF mode ?

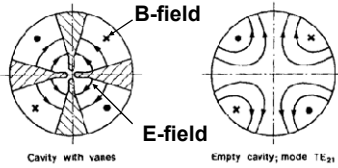

The TE₂₁₀ mode in the “4-vane” structure and in the empty cavity.

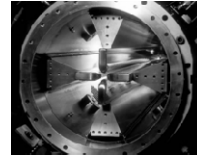

Alternative resonator design: the “4-rod” structure, where an array of $\lambda/4$ parallel plate lines loads four rods, connected in such a way as to provide the quadrupole field.

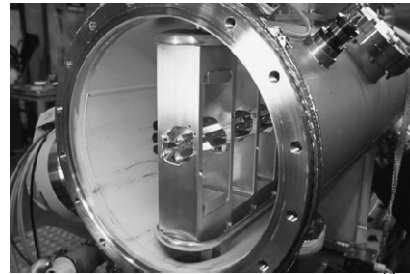
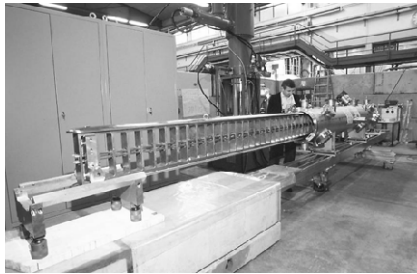

7. Linac Technologies

Linac building blocks

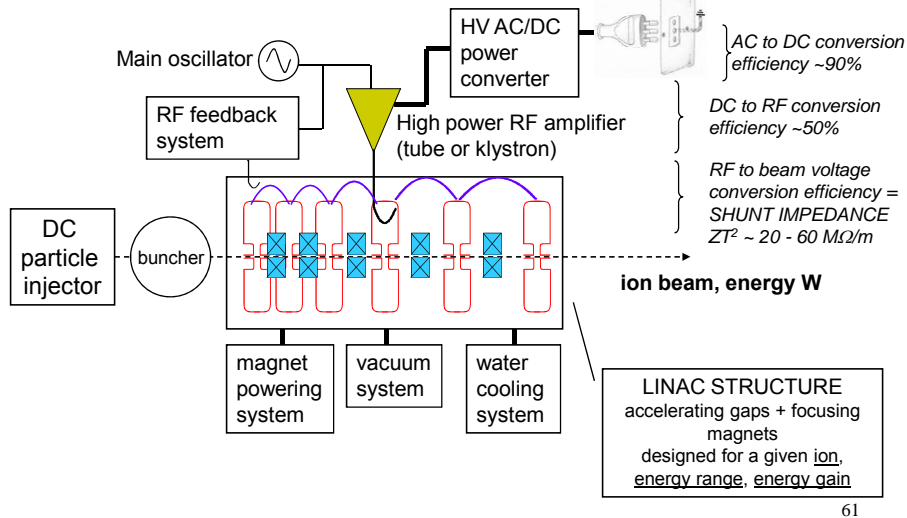

61

Particle production - the sources

Electron sources:
 give energy to the free electrons inside a metal to overcome the potential barrier at the boundary.
 Used for electron production:

- > thermoionic effect
- > laser pulses
- > surface plasma

Ion sources:
 create a plasma and optimise its conditions (heating, confinement and loss mechanisms) to produce the desired ion type. Remove ions from the plasma via an aperture and a strong electric field.

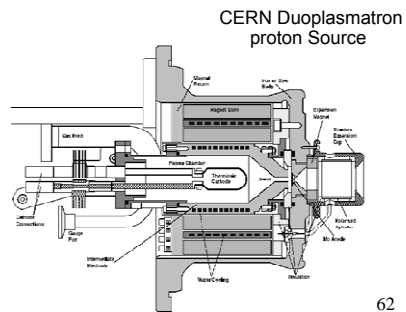
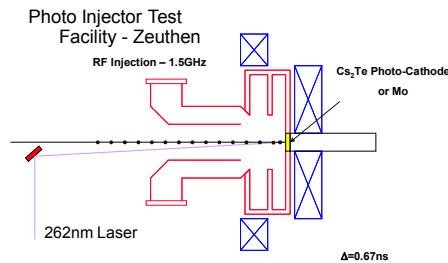

62

Ion injector (CERN Linac1)

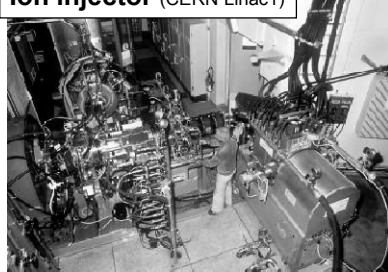

Electron injector (CERN LIL)

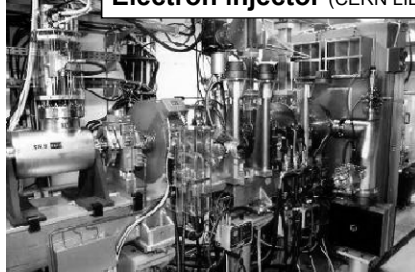

3 common problems for protons and electrons after the source, up to ~1 MeV energy:

1. large space charge defocusing
2. particle velocity rapidly increasing
3. need to form the bunches

Solved by a special injector

Ions: RFQ bunching, focusing and accelerating.

Electrons: Standing wave bunching and pre-accelerating section.

☞ For all particles, the injector is where the emittance is created!

63

approximate scaling laws for linear accelerators:

☞ RF defocusing (ion linacs)	~ frequency
☞ Cell length ($=\beta\lambda/2$)	~ (frequency) ⁻¹
☞ Peak electric field	~ (frequency) ^{1/2}
☞ Shunt impedance (power efficiency)	~ (frequency) ^{1/2}
☞ Accelerating structure dimensions	~ (frequency) ⁻¹
☞ Machining tolerances	~ (frequency) ⁻¹

- Higher frequencies are economically convenient (shorter, less RF power, higher gradients possible) but limitation comes from mechanical precision in construction (tight tolerances are expensive!) and beam dynamics for ion linacs at low energy.
- Electron linacs tend to use higher frequencies (0.5-12 GHz) than ion linacs. Standard frequency 3 GHz (10 cm wavelength). No limitations from beam dynamics, iris in TW structure requires less accurate machining than nose in SW structure.
- Proton linacs use lower frequencies (100-800 MHz), increasing with energy (ex.: 350 - 700 MHz): compromise between focusing, cost and size.
- Heavy ion linacs tend to use even lower frequencies (30-200 MHz), dominated by the low beta in the first sections (CERN RFQ at 100MHz, 25 keV/u: $\beta\lambda/2=3.5\text{mm}$!)

→ Type of RF power source depend on frequency:

- ☞ Klystrons (>350 MHz) for electron linacs and modern proton linacs. RF distribution via waveguides.
- ☞ RF tube (<400 MHz) or solid state amplifiers for proton and heavy ion linacs. RF distribution via coaxial lines.

→ Construction technology depends on dimensions (→on frequency):

- ☞ brazed copper elements (>500 MHz) commonly used for electron linacs.
- ☞ copper or copper plated welded/bolted elements commonly used for ion linacs (<500 MHz).

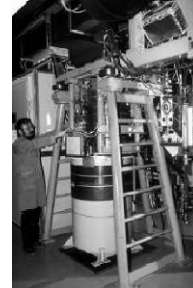

3 GHz klystron (CERN LPI)

200 MHz triode amplifier (CERN Linac3)

65

Note that the optimum design gradient (E_0T) in a normal-conducting linac is not necessarily the highest achievable (limited by sparking).

- The cost of a linear accelerator is made of 2 terms:
- a "structure" cost proportional to linac length
 - an "RF" cost proportional to total RF power

$$C = C_s l + C_{RF} P$$

C_s, C_{RF} unit costs (€/m, €/W)

$$\begin{aligned} l &\propto 1/E_0T \\ P &\propto (E_0T)^2 l \propto E_0T \end{aligned} \implies C \propto C_s \frac{1}{E_0T} + C_{RF} E_0T$$

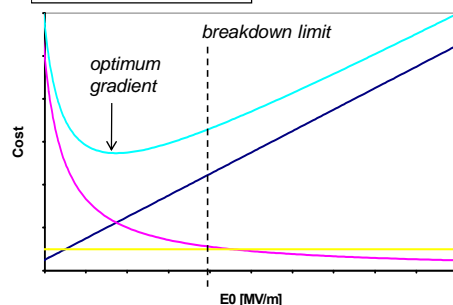

Total cost
RF cost

Overall cost is the sum of a structure term decreasing with the gradient and of an RF term increasing with the gradient → there is an optimum gradient minimizing cost.

Example: for Linac4
 $C_s \dots \sim 200$ kCHF/m
 $C_{RF} \dots \sim 0.6$ CHF/W (recuperating LEP equipment)
 $E_0T \dots \sim 3 - 4$ MV/m

structure cost

66

Advantages:

- Much smaller RF system (only beam power) → prefer low current/high duty
- Large aperture (lower beam loss in the SC section).
- Lower operating costs (electricity consumption).



Disadvantages:

- Need cryogenic system (in pulsed machines, size dominated by static loss → prefer low repetition frequency or CW to minimize filling time/beam time).
- Need cold/warm transitions to accommodate quadrupoles → becomes more expensive at low energy (short focusing periods).
- Individual gradients difficult to predict (large spread) → need large safety margin in gradient at low energy.

Conclusions:

1. Superconductivity gives a large advantage in cost at high energy / high duty cycle.
2. At low energy / low duty cycle superconducting sections become expensive.

67

What is new (& hot) in the field of linacs?

1. Frequencies are going up for both proton and electron linacs (←less expensive precision machining, efficiency scales roughly as \sqrt{f}). Modern proton linacs start at 350-400 MHz, end at 800-1300 MHz. Modern electron linacs in the range 3-12 GHz.
2. Superconductivity is progressing fast, and is being presently used for both electron and ion linacs → multi-cell standing wave structures in the frequency range from ~100 MHz to 1300 MHz.

Superconductivity is now bridging the gap between electron and ion linacs.

The 9-cell TESLA/ILC SC cavities at 1.3 GHz for electron linear colliders, are now proposed for High Power Proton Accelerators (Fermilab 8 GeV linac)!

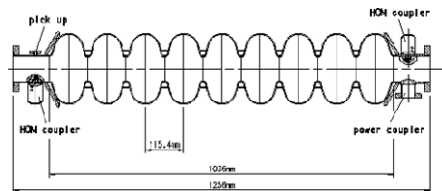

68



Bibliography



1. Reference Books:

- T. Wangler, Principles of RF Linear Accelerators (Wiley, New York, 1998).
P. Lapostolle, A. Septier (editors), Linear Accelerators (Amsterdam, North Holland, 1970).
I.M. Kapchinskii, Theory of resonance linear accelerators (Harwood, Chur, 1985).

2. General Introductions to linear accelerators

- M. Puglisi, The Linear Accelerator, in E. Persico, E. Ferrari, S.E. Segré, Principles of Particle Accelerators (W.A. Benjamin, New York, 1968).
P. Lapostolle, Proton Linear Accelerators: A theoretical and Historical Introduction, LA-11601-MS, 1989.
P. Lapostolle, M. Weiss, Formulae and Procedures useful for the Design of Linear Accelerators, CERN-PS-2000-001 (DR), 2000.
P. Lapostolle, R. Jameson, Linear Accelerators, in Encyclopaedia of Applied Physics (VCH Publishers, New York, 1991).

3. CAS Schools

- S. Turner (ed.), CAS School: Cyclotrons, Linacs and their applications, CERN 96-02 (1996).
M. Weiss, Introduction to RF Linear Accelerators, in CAS School: Fifth General Accelerator Physics Course, CERN-94-01 (1994), p. 913.
N. Pichoff, Introduction to RF Linear Accelerators, in CAS School: Basic Course on General Accelerator Physics, CERN-2005-04 (2005).
M. Vretenar, Differences between electron and ion linacs, in CAS School: Small Accelerators, CERN-2006-012.