

High beta cavity

G. Devanz CEA-Saclay

Activities contracted to Saclay

Design activities

- High beta cavity design+tuner+tank
- Power coupler design
- HOM design, starting

Prototyping activities

- Two high beta cavity prototypes tested within ADU. Drawings are ready
- 6 fully equipped cavities (tank+ tuner+power c couplers)

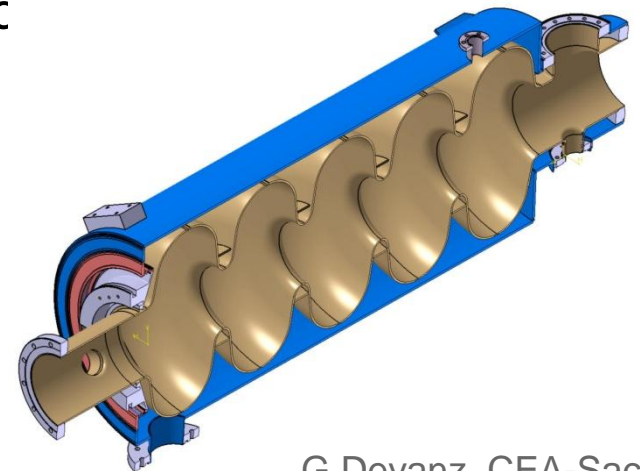

RF design

Advantages of high cell to cell coupling for TM_{01} :

- easier to obtain field flatness, control over peak fields distribution among cells
- more consistent Q_{ext} across cavities
- enhanced mode separation between π and $4\pi/5$ modes
- HOM also better coupled to the outer cells (needed for damping)

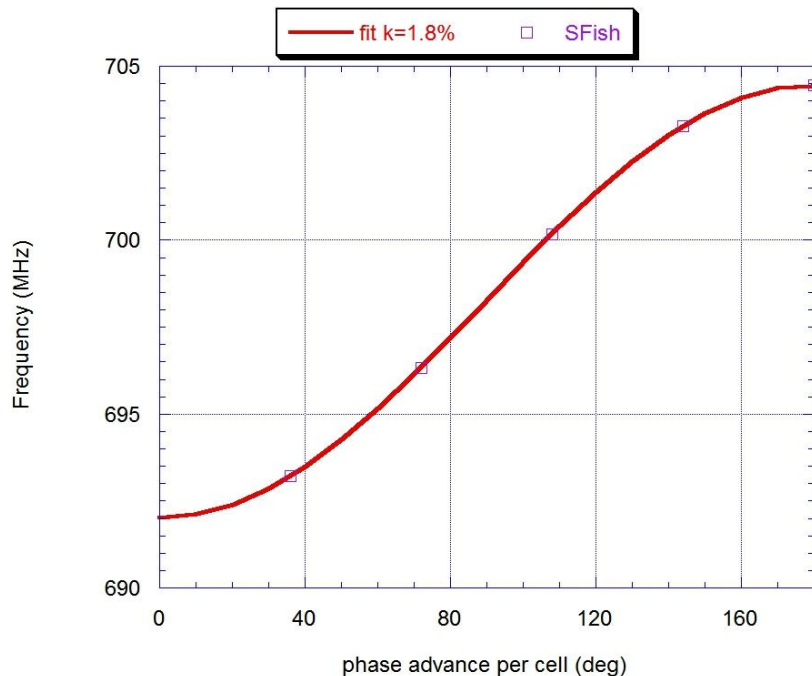

β $g=0.86$		unit
Frequency	704.42	MHz
Nr of cells	5 (sym.)	
Cell to cell coupling	1.8	%
π and $4\pi/5$ mode separation	1.2	MHz
E_{pk}/E_{acc}	2.2	
B_{pk}/E_{acc}	4.3	mT/(MV/m)
Max. r/Q	477 @ $\beta=0.92$	Ω
G	241	Ω
Low field Q_0	$2.4e10$ ($R_s=10$ n Ω)	

RF design – End groups and Qext

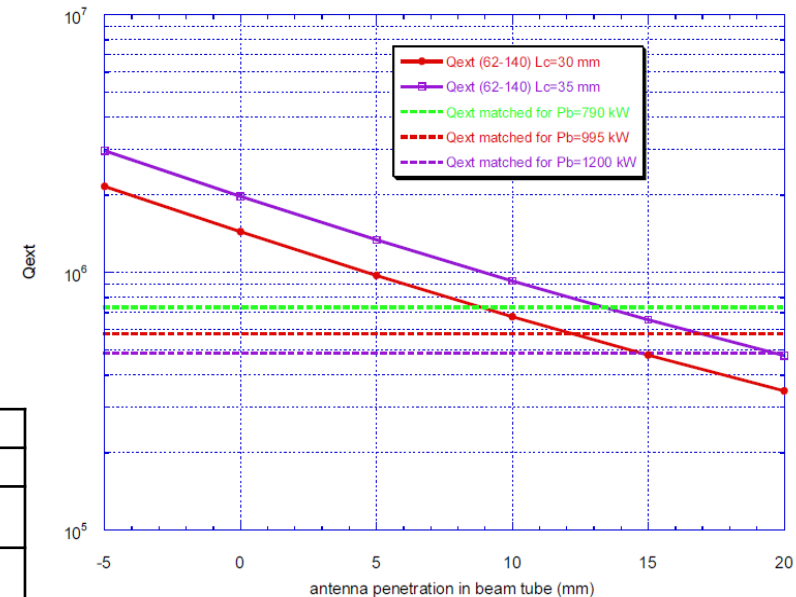
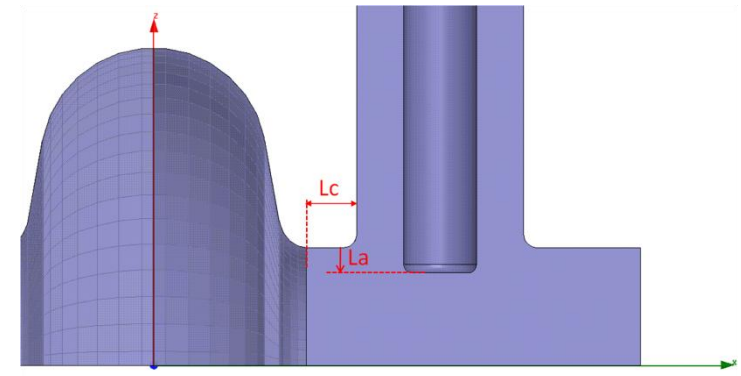
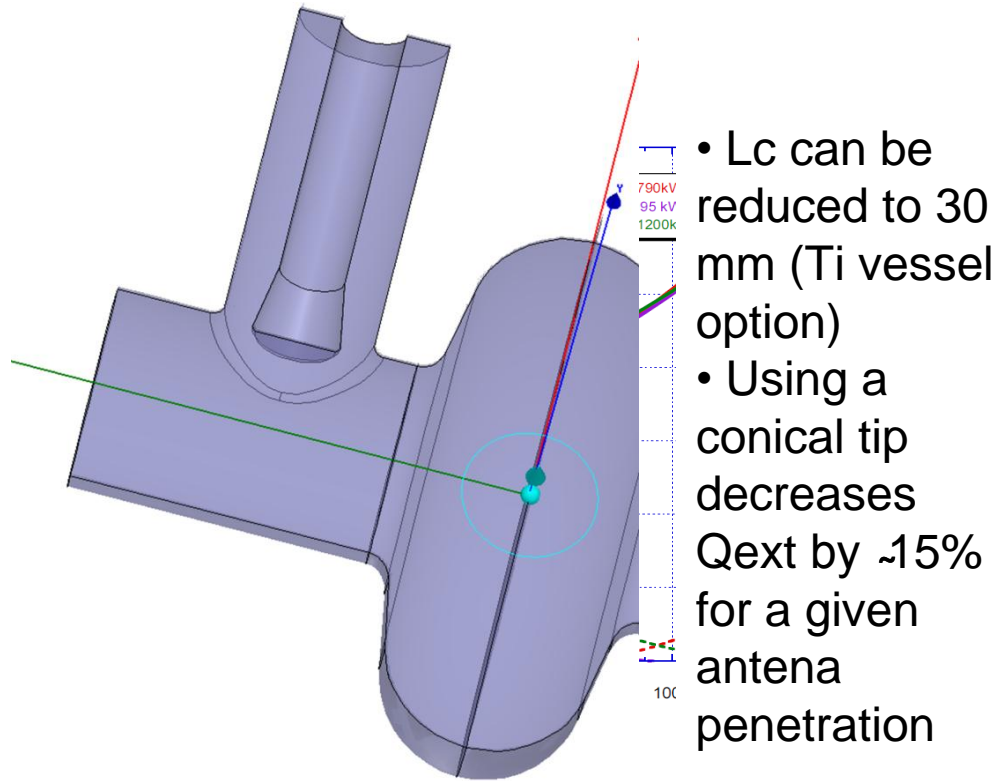

Diameter (mm)	Cut-off frequencies (GHz)						
	TE11	TM01	TE21	TM11	TE01	TE31	TM21
130	1.3535	1.7683	2.2405	2.8143	2.8143	3.0769	3.7831
140	1.2568	1.6420	2.0804	2.6132	2.6132	2.8571	3.5129

I_b=50 mA and E_{acc}=18 MV/m correspond to 790kW beam power and matched Qext=7.1e5
 A beam tube diameter of 140 mm is necessary to achieve the coupling with Lc=35 mm (constrained by the mechanical design of He vessel and coupler flange)

RF design – HOMs

Monopole HOM for the 5-cell below cutoff

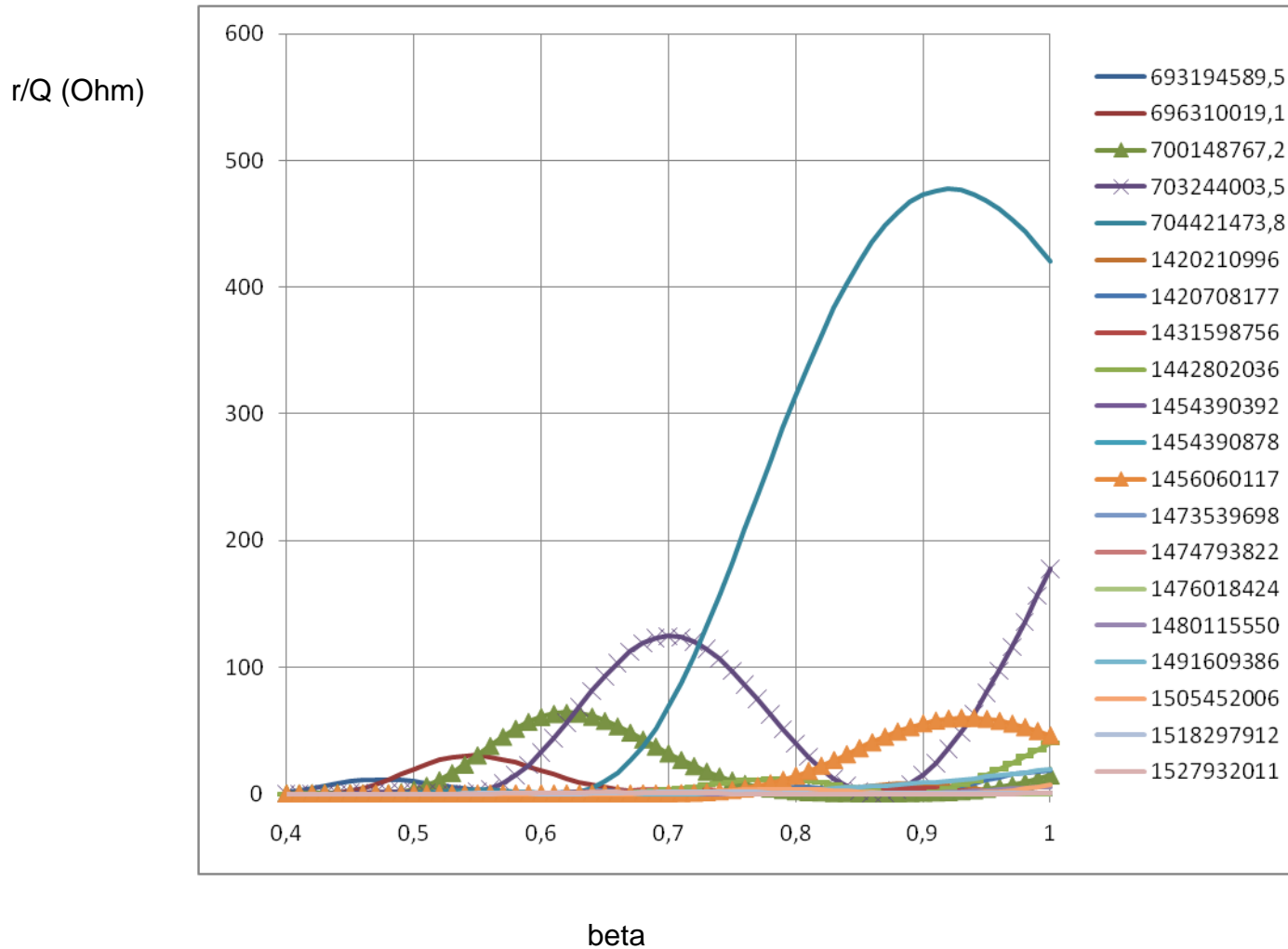

RF design – HOMs

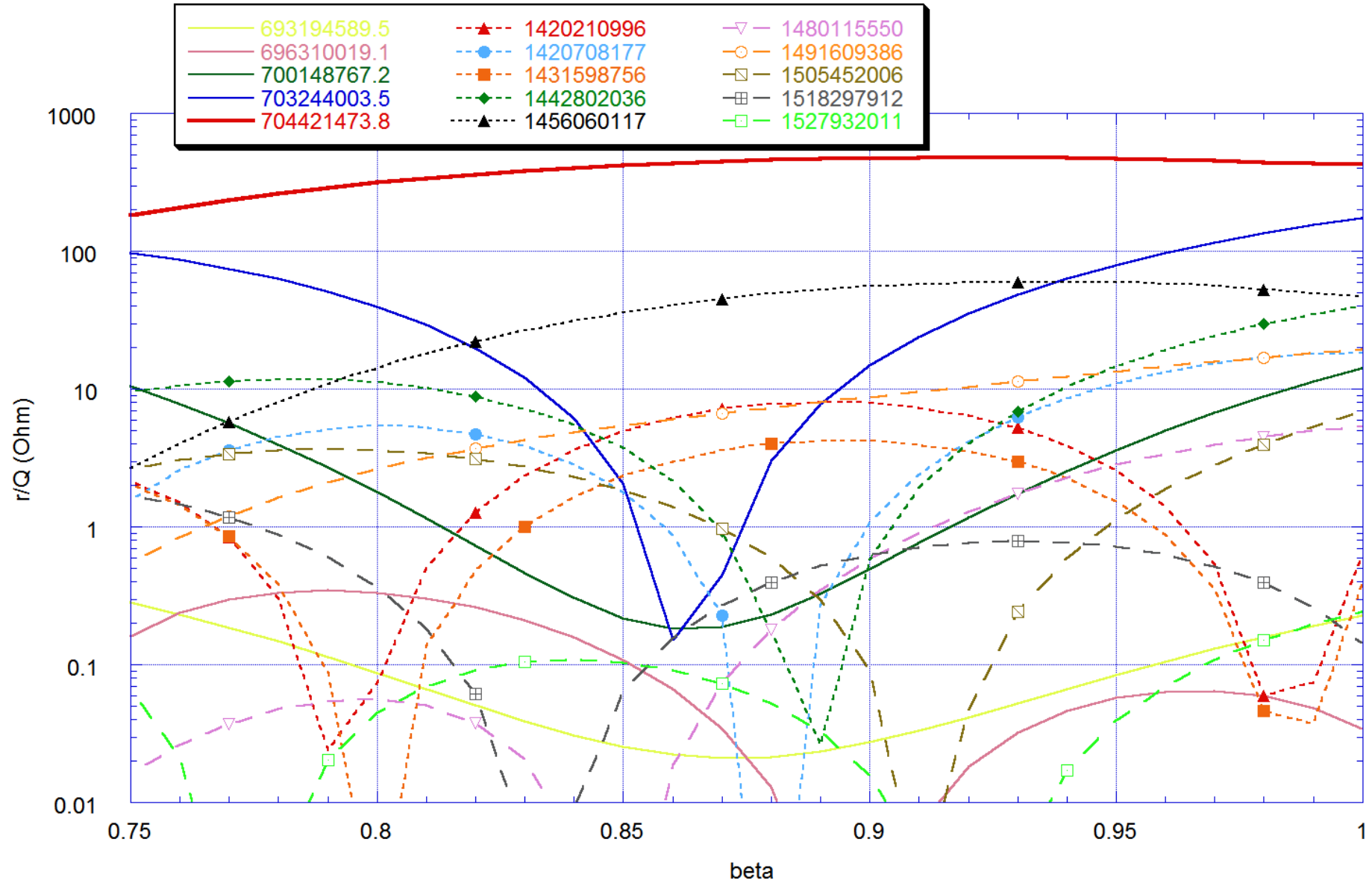

RF design – HOMs – first TM band

Freq	Q	Max. r/Q
1,420314E+09	1,58E+05	8
1,421856E+09	4,30E+03	17
1,431672E+09	3,22E+04	4
1,442845E+09	3,30E+04	29
1,456038E+09	4,41E+04	60

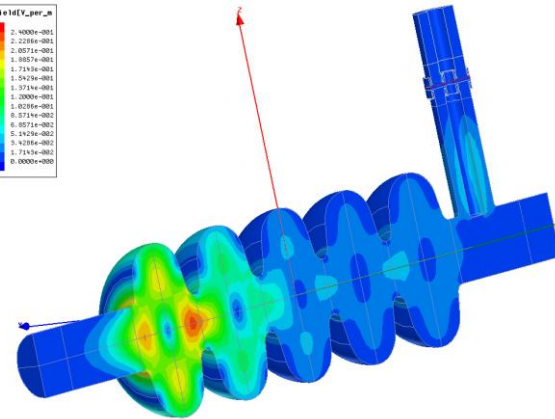
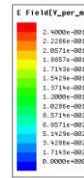

RF window included
Copper losses from
- power coupler
- inter-cavity bellows

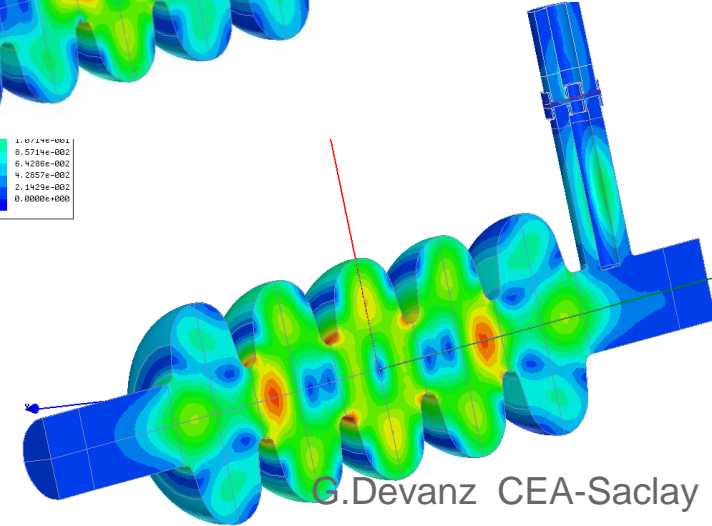
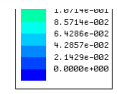
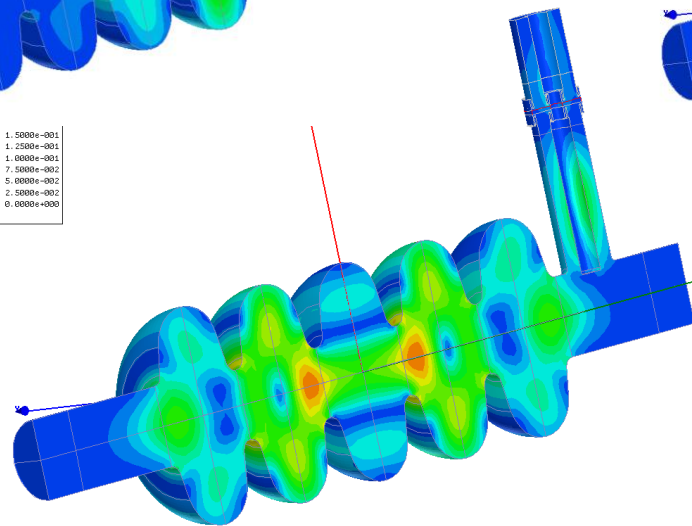
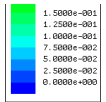
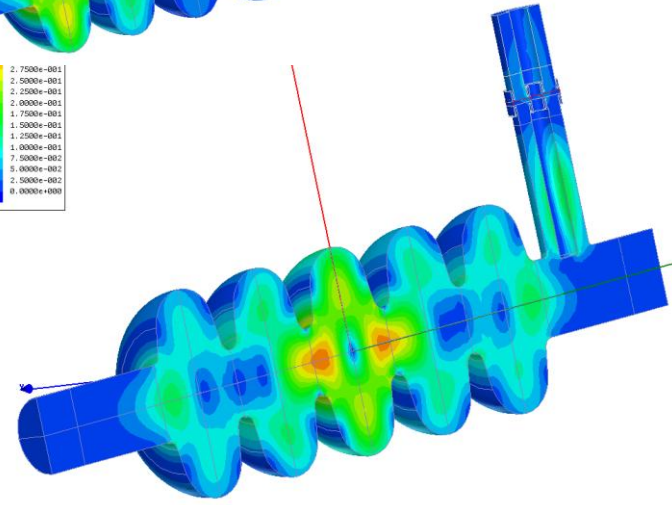
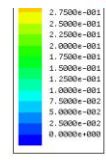
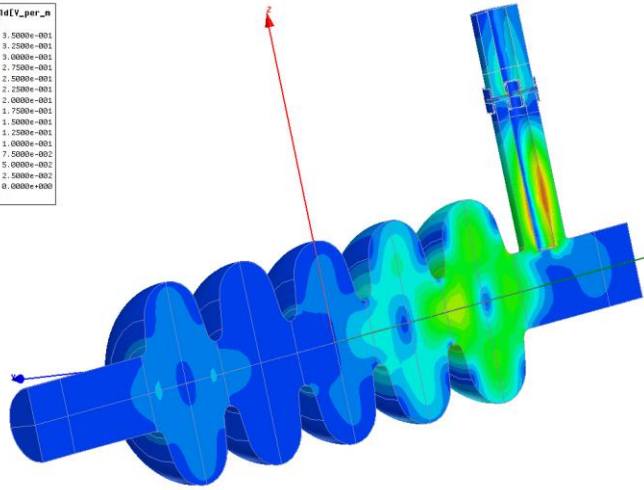
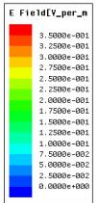

RF design – HOMs – TM02 band

Freq	Q	Max. r/Q
1,480140E+09	1,98E+04	5
1,491491E+09	1,33E+04	17
1,505236E+09	1,40E+04	4
1,518154E+09	1,87E+04	4
1,527895E+09	4,57E+04	0,2

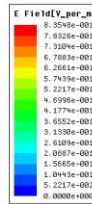

RF window included
Copper losses from
- power coupler
- inter-cavity bellows

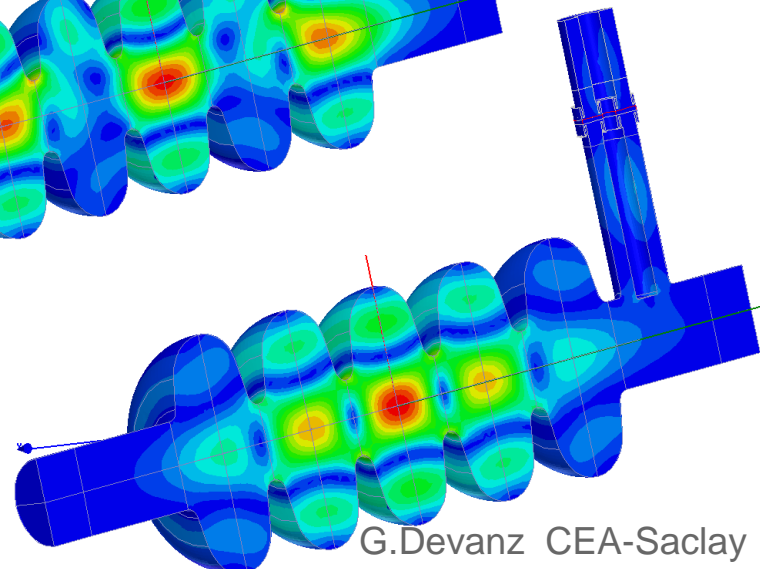
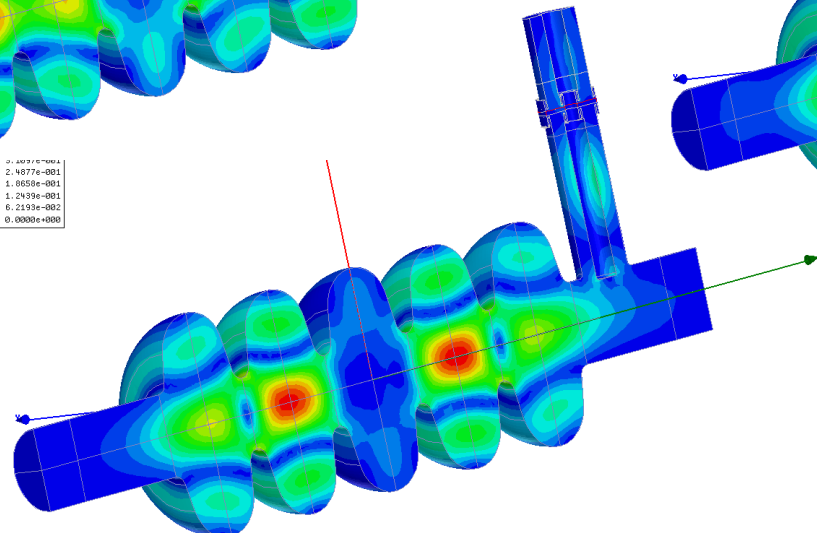
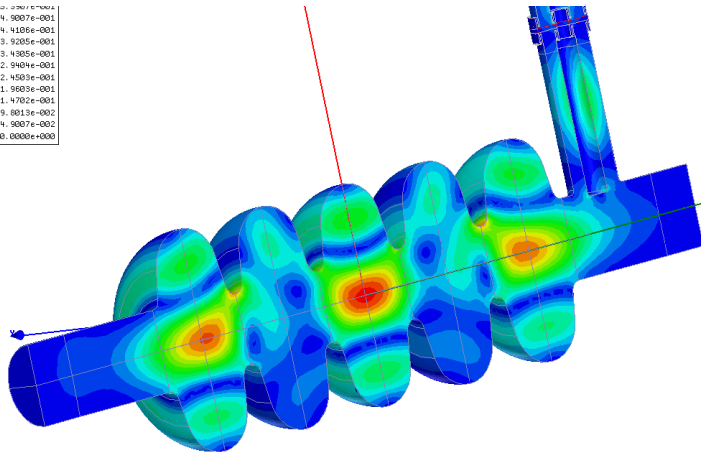
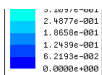
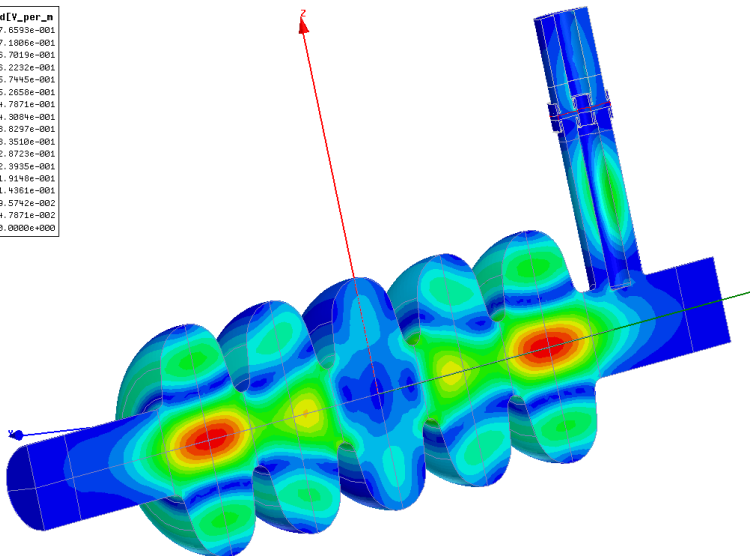
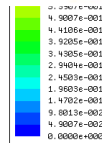
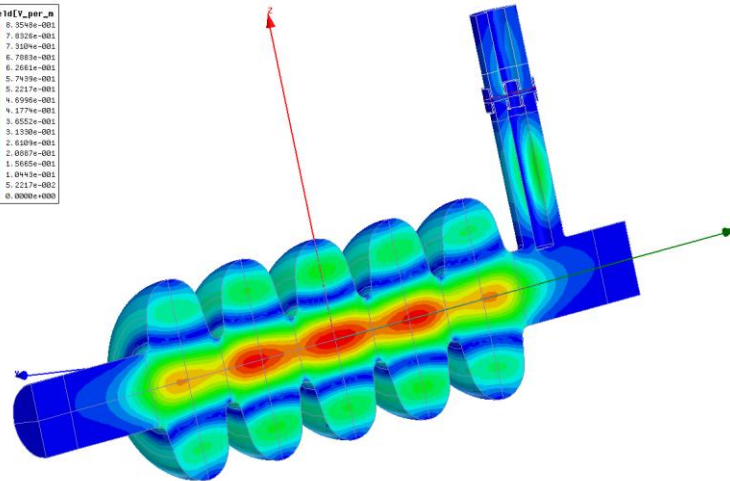

Prototype features

- Two HOM ports 50 mm diam. Equipped with flanges. Position is as close to the iris as permitted by the flange and He tank.
- 105 angle between couplers
- Prototype HOM couplers will not be ready for the vertical tests at the end of next year, but HOM spectrum measurements will be carried out. We can make a survey of frequency shifts for individual HOMs during all cavity preparation phases

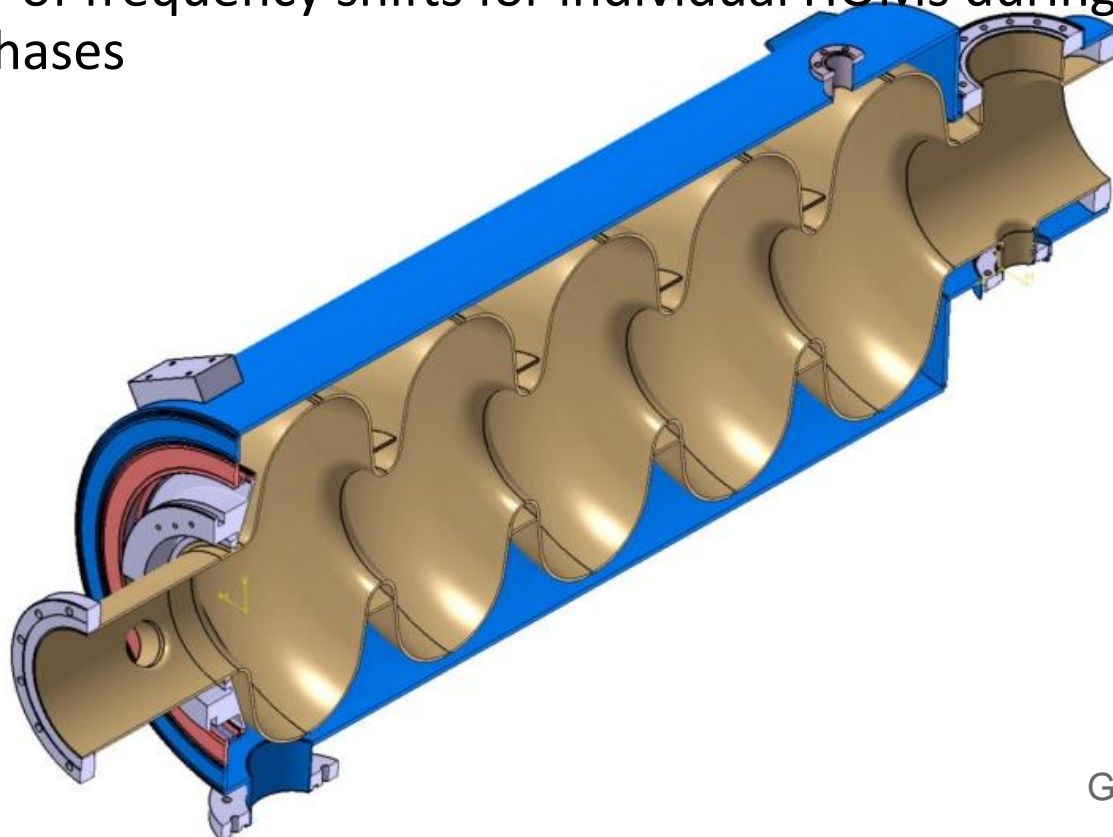

Cryomodule layout

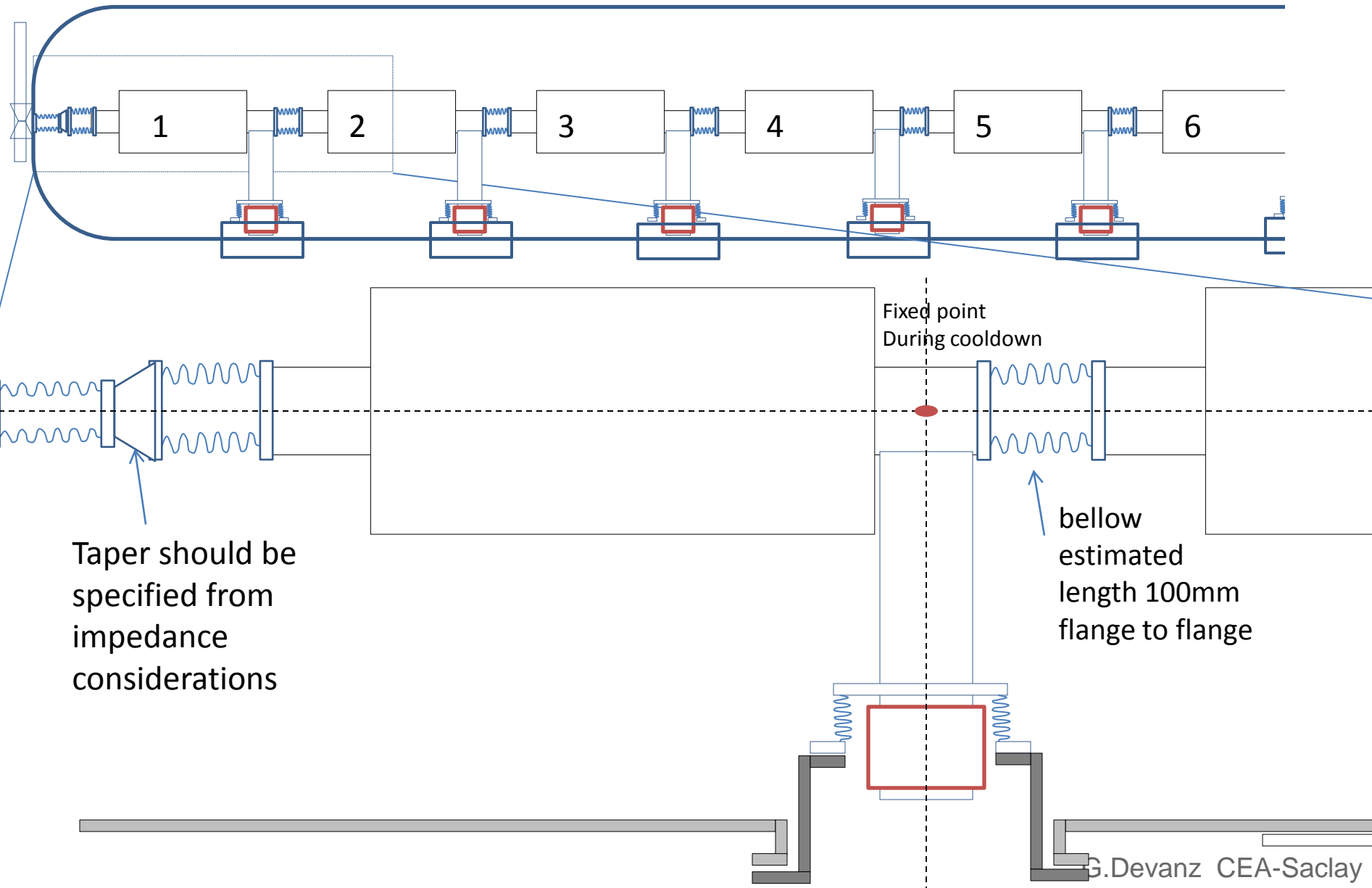

Questions to solve

- Straight beam tube geometry + lossy tapers at cryomodule extremities+ normal conducting bellows between cavities (choice for the prototype cavities)

OR

- SC tapers part of each cavity beam tube+smaller diameter N.C. bellows between cavities
 - Linked to cryomodule design,
 - electropolishing process design (cathode diameter)

How many HOM couplers, 2,1,0 ?

Damping specifications: in which terms?

- Q_{ext} for monopole and Q_{ext}' for dipoles?
- a maximum impedance $(r/Q)*Q_{ext}$?
- Do we need to damp the dipole, quadrupole modes, etc, in a proton linac? SPL-HOM meeting of june 2009 conclusion was: no

Some words about multipactor

- Benchmarking of codes is needed.
- Simulation of HOM couplers that actually work without problems even more important. DESY HOM coupler is a good candidate to check the MP simulation codes.
- Experience from HOM couplers developed at Saclay in the 90's: rejection filter capacitance with a large surface cause MP problems in a coaxial configuration. Breaking coaxial symmetry is the way to go: either stable trajectories concentrating impact points on a small surface area, or making trajectories unstable.
- Concentrating the impacts on a small surface area is the way to condition MP faster (if cooling is sufficient) SEY reduction depends on dose.
- Experience from testing SRF cavities: the same cavity tested twice: fatal MP to no MP at all just by changing the drying conditions in the clean room
- HOM couplers are part of the cavity and get the same surface processing (chemical etching, high pressure rinse). The shape should not create traps for acids or water, and all surfaces should be swept by HPWR water jets

Checking MP sensitivity to material surface condition

Secondary emission coefficient for Nb

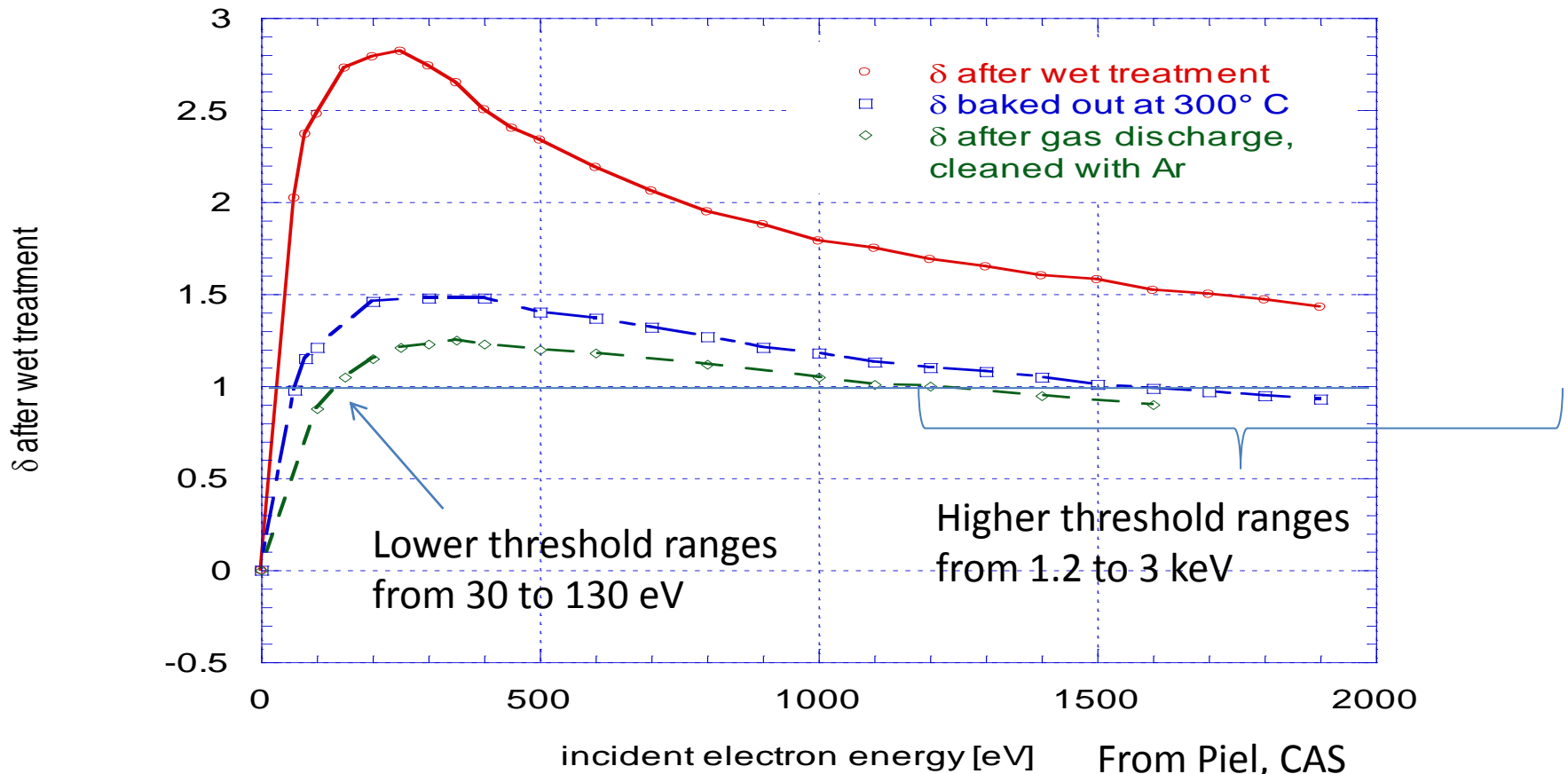

Normal incidence data