

# Scintillating Fibres Front-End Electronic ECS

Hervé Chanal

13<sup>th</sup> December 2012

# Foreseen readout electronic

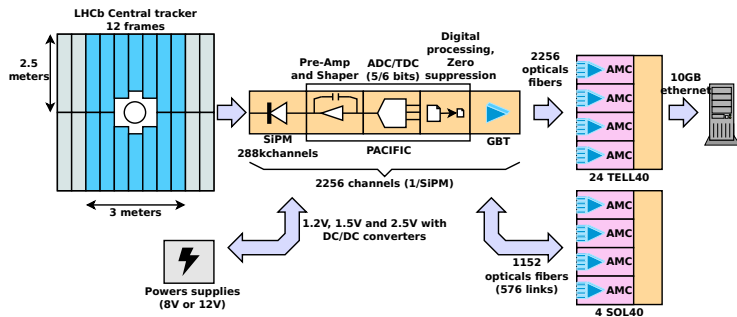

## Number of GBT links

The FE board output bandwidth studies are not yet finished. Hence, it is order of magnitudes :

- ▶ For data  $\approx 2300$  fibres ;
- ▶ For ECS  $\approx 600$  links (bidirectional) ;

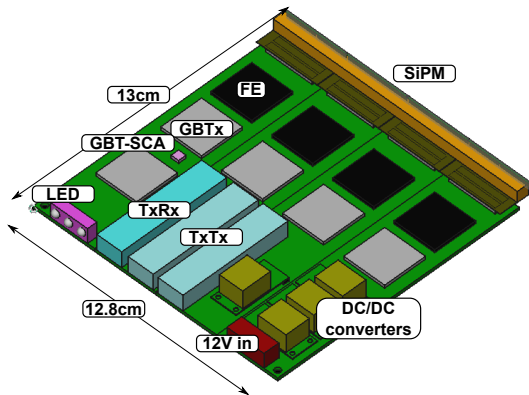

## Rough state

Order of magnitudes :

- ▶ 576 boards;
- ▶ 1 SCA/Master GBT;
- ▶ User bus : 4  $I^2C$  bus, 1 JTAG bus.

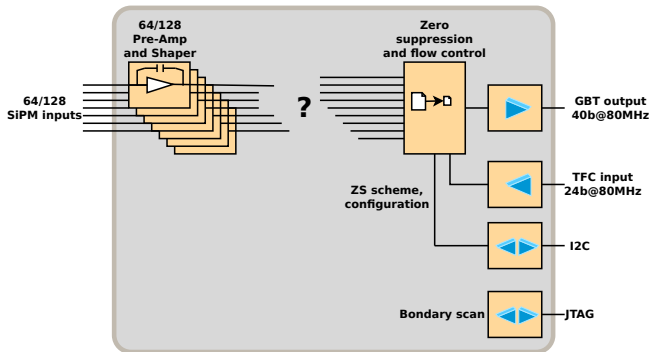

## Well defined

The final processing is not yet defined (rough numbers):

- ▶ Channel configuration 10kb;
- ▶ PACIFIC configuration 2.5kb;
- ▶ Board configuration 50kb;
- ▶  $\approx 50$  registers/chip;
- ▶ Monitoring : temperature, cluster rate... a few kb/min/board.