

The Compressed Baryonic Matter experiment at FAIR

Johann M. Heuser
GSI, Darmstadt, Germany

for the CBM Collaboration

Quark Matter 2012, Washington DC



CBM physics program

Explore the QCD phase diagram:

- equation-of-state at high ρ_B
- deconfinement phase transition
- QCD critical endpoint
- chiral symmetry restoration

Probes of the high-density phase:

- open charm, charmonia
- low-mass vector mesons
- multistrange hyperons
- flow, fluctuations, correlations

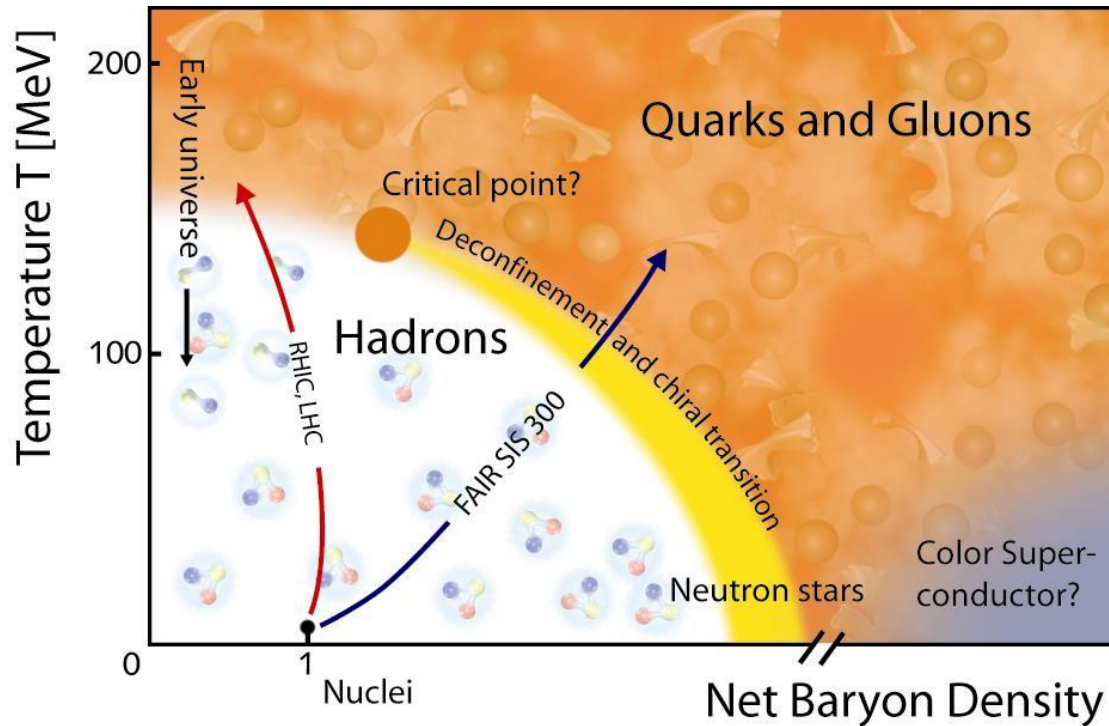

Experiments on super-dense nuclear matter

Experiment	Energy range (Au/Pb beams)	Reaction rates Hz	Observables, $\sqrt{s_{NN}}= 8 \text{ GeV}$			
			hadrons	flow, fluct., correl.	dileptons	charm
STAR@RHIC BNL	$\sqrt{s_{NN}} = 7 - 200 \text{ GeV}$	1 – 800 (limit luminosity)	yes	no	no	no
NA61@SPS CERN	$E_{kin} = 20 - 160 \text{ AGeV}$ $\sqrt{s_{NN}} = 6.4 - 17.4 \text{ GeV}$	80 (limit detector)	yes	no	no	no
MPD@NICA Dubna	$\sqrt{s_{NN}} = 4.0 - 11.0 \text{ GeV}$	~1000 (at design luminosity)	yes	yes	no	no
CBM@FAIR Darmstadt	$E_{kin} = 2.0 - 35 \text{ AGeV}$ $\sqrt{s_{NN}} = 2.7 - 8.3 \text{ GeV}$	$10^5 - 10^7$ (limit detector)	yes	yes	yes	yes

Observables

minimum bias Au+Au collisions at 25 AGeV
(from HSD and thermal model)

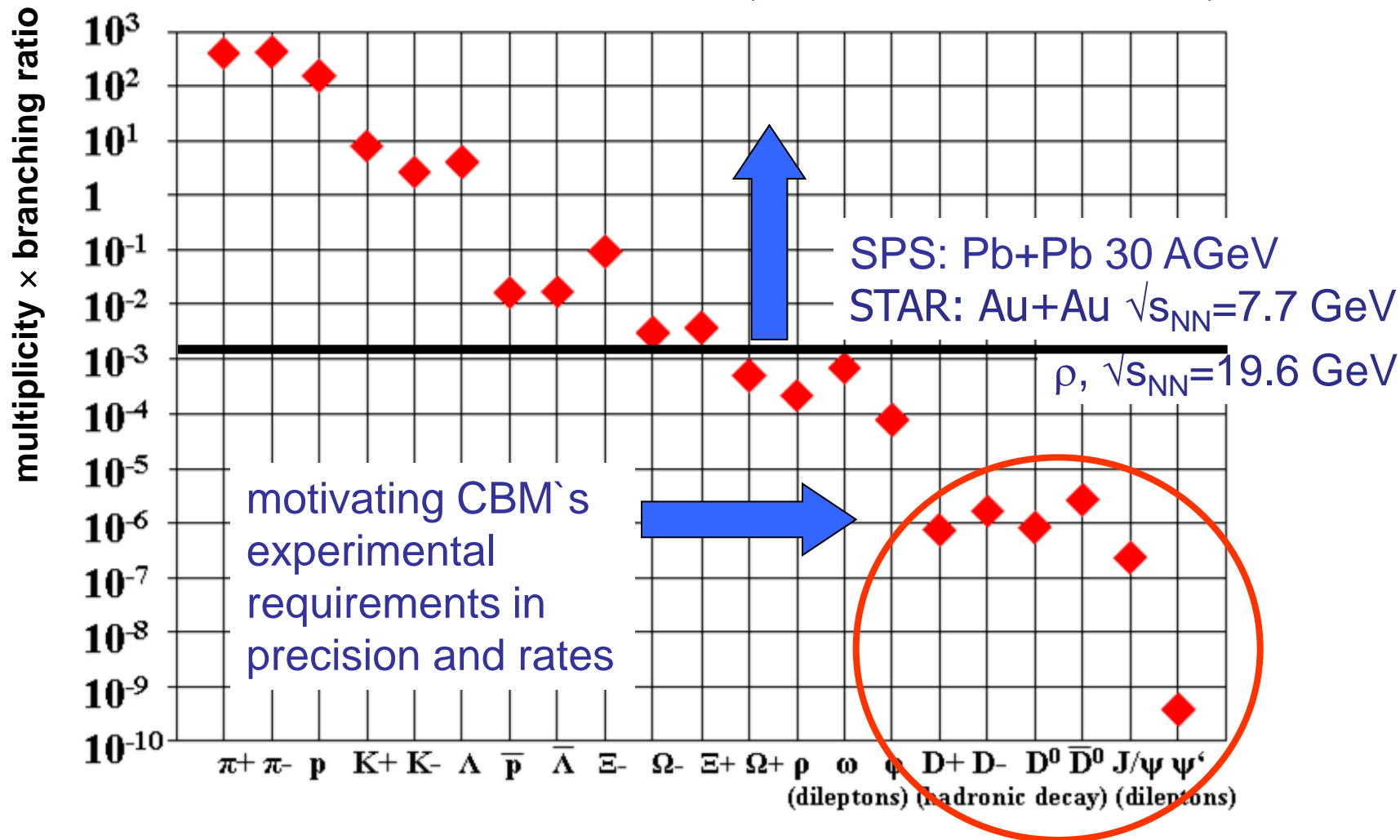

CBM physics book

Lecture Notes in Physics Vol. 814

April 29, 2011

1000 pages, 400 figures, 2000 citations

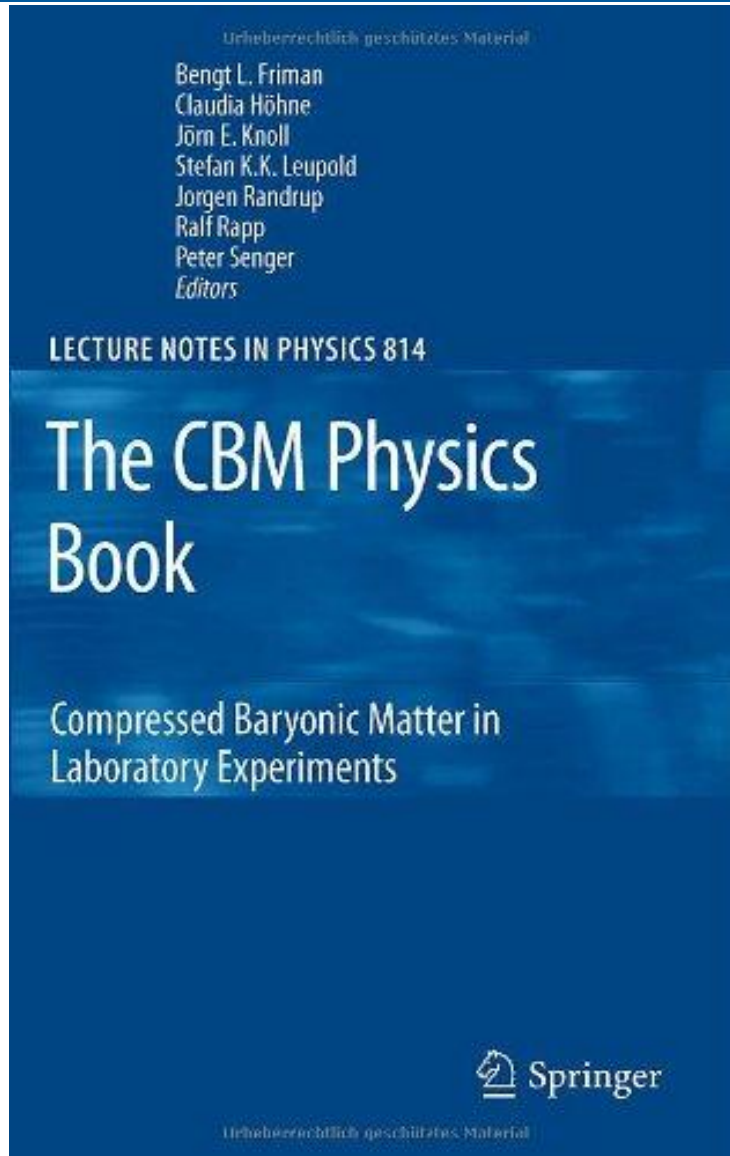

General Introduction
Prelude by Frank Wilczek
Facets of Matter
Executive Summary

Part I

*BULK PROPERTIES OF STRONGLY
INTERACTING MATTER*

Part II

IN-MEDIUM EXCITATIONS

Part III

COLLISION DYNAMICS

Part IV

OBSERVABLES AND PREDICTIONS

Part V

CBM EXPERIMENT

Facility for Antiproton and Ion Research

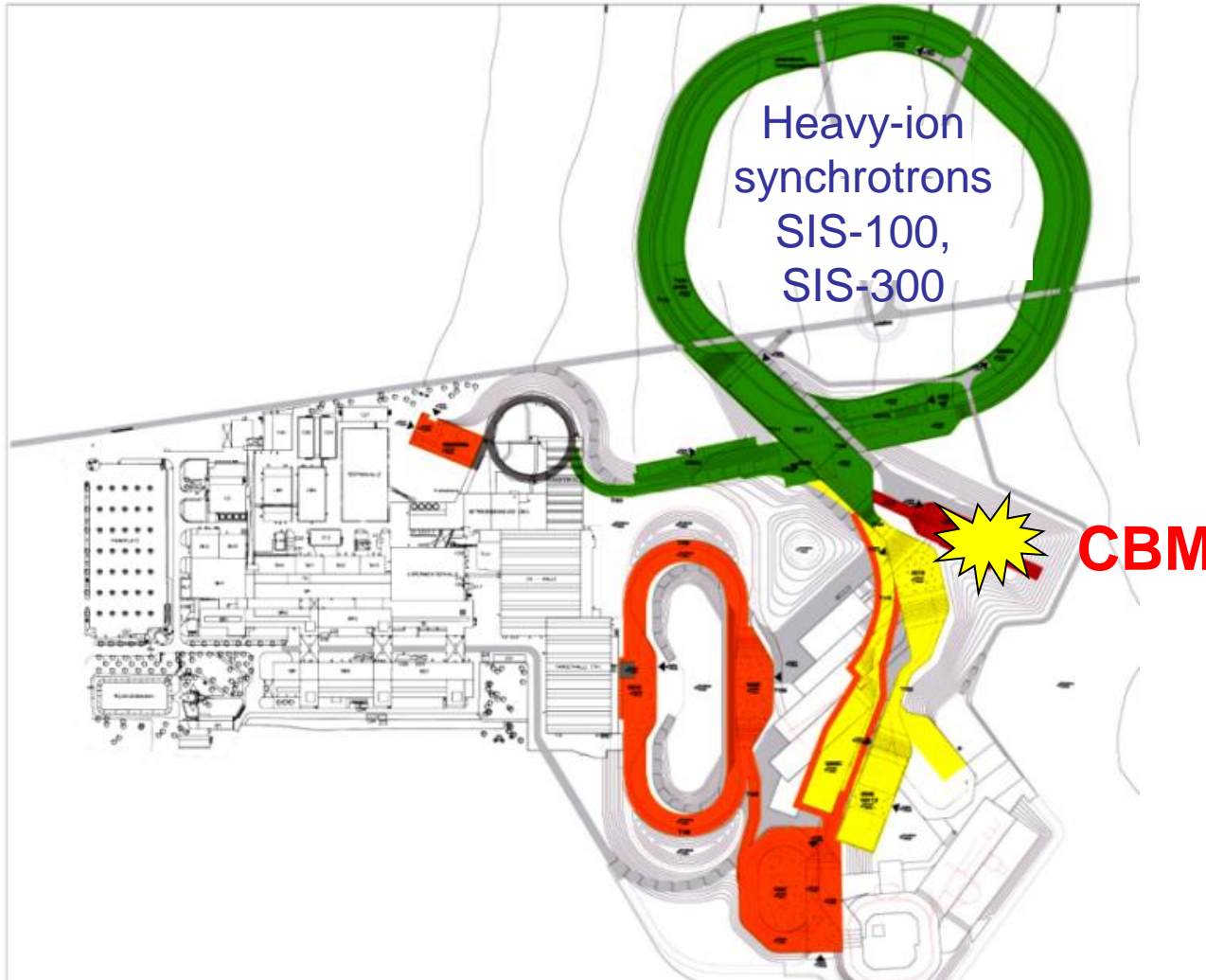

- CBM is one of the four scientific pillars at FAIR
- Civil construction of FAIR has started

SIS-100 / SIS-300:

- *protons:*
2 - 29/89 GeV
- *ions:*
2 - 14/44 AGeV,
 $\sqrt{s_{NN}} = 1.9 - 4.5 /$
4.2 - 9 GeV
- *intensities:*
up to 10^9 ions per second at CBM

CBM experimental hall

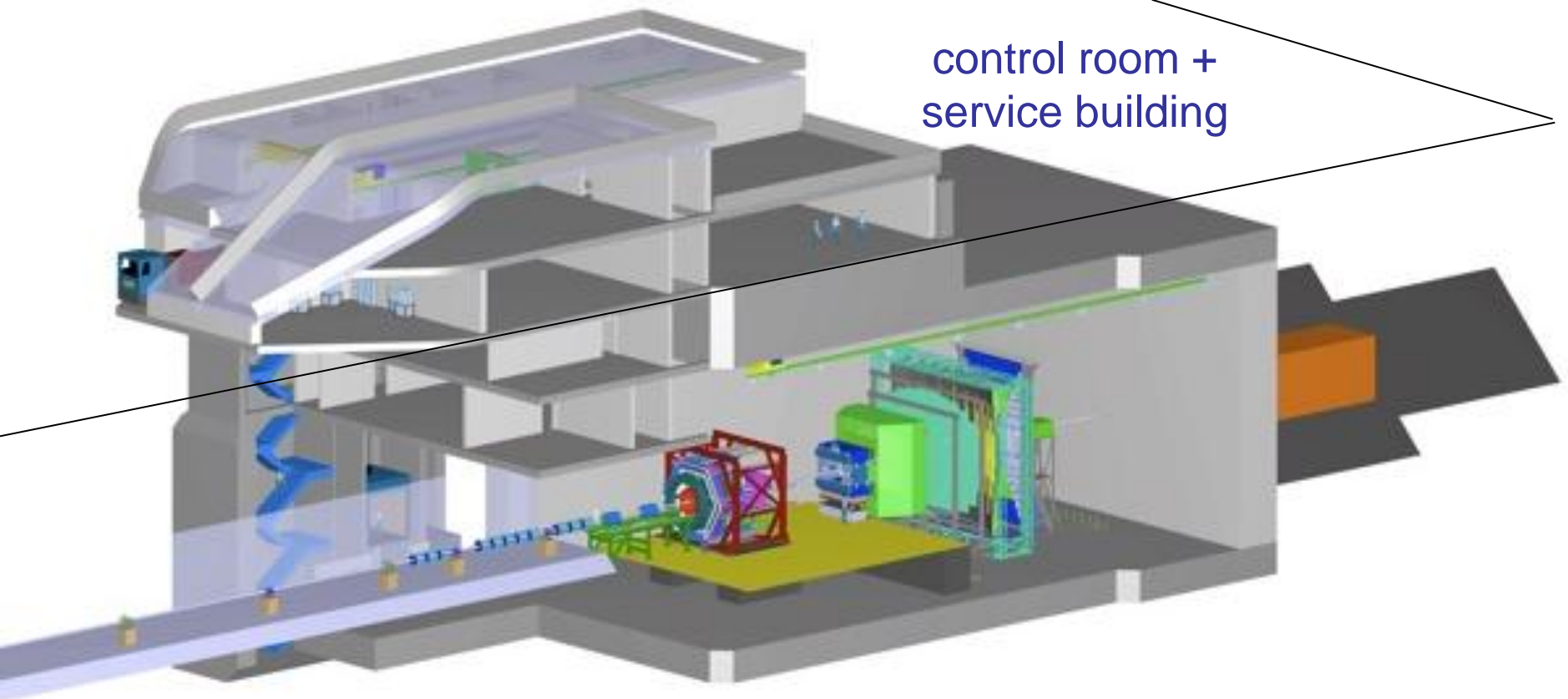

control room +
service building

building application filed

underground hall: length: 37 m
 width: 27 m
 height: 17 m

Construction of FAIR

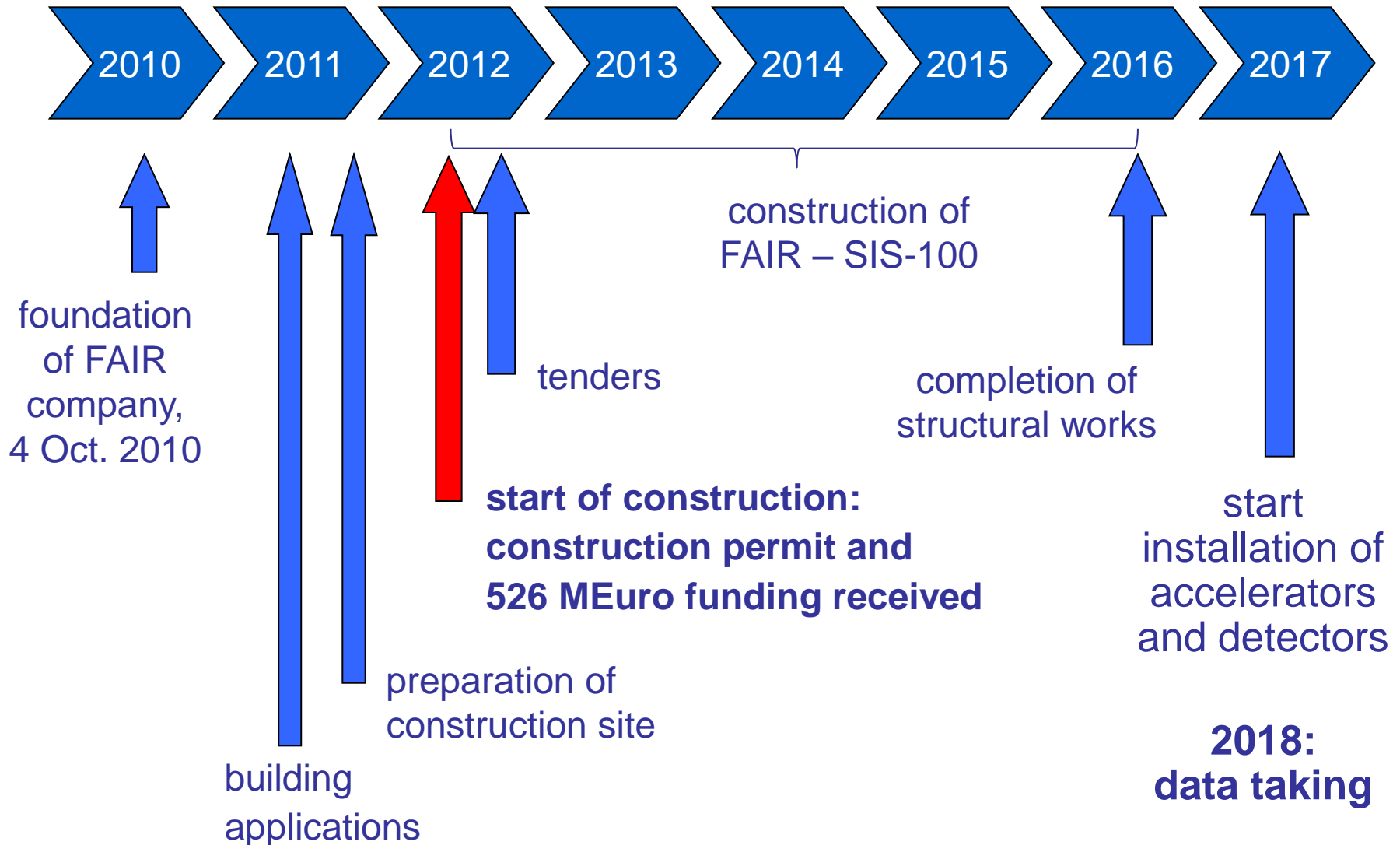

Civil construction of FAIR

FAIR site preparation



Spring 2012



Summer 2011



Winter 2011/12



Status of the accelerators

Dipole magnets for SIS-100



Babcock-Noell

Prototypes for industrial mass production have been developed.

Important milestone:

SIS-100 dipole series has been tendered.

Dipole magnets for SIS-300

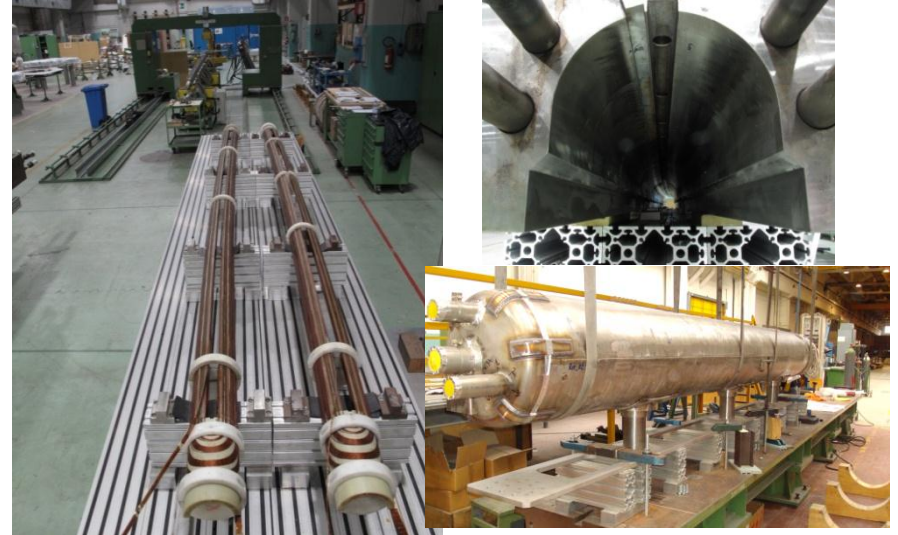

Breakthrough in July 2012:

Successful test of the first curved prototype dipole (*DISCORAP Collaboration, LASA lab, INFN Milan, Italy*)

- fields up to 4.5 T
- field ramps (currently limited to 0.4 T/s)

The CBM experiment

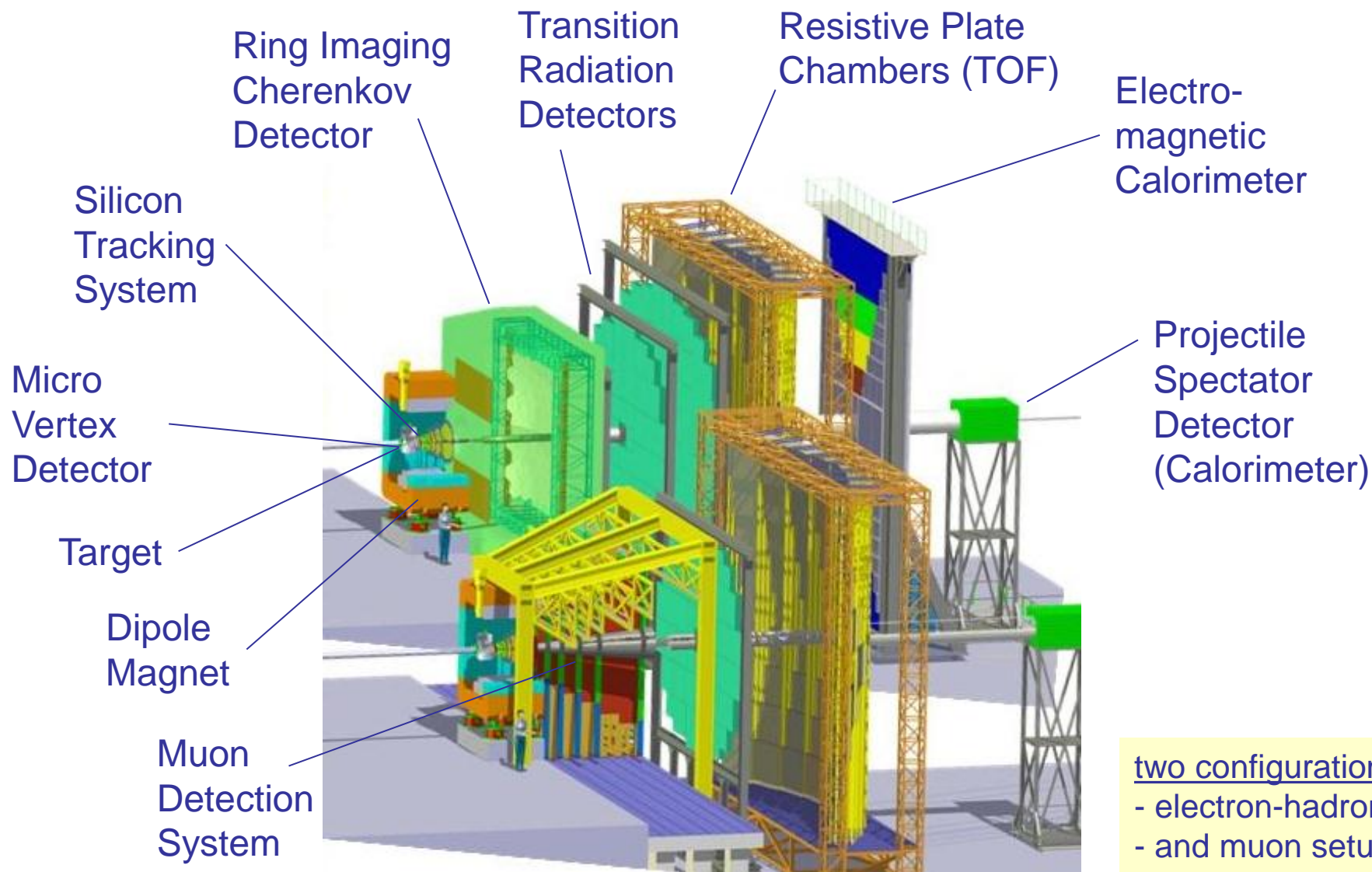

Experimental challenges

Central Au+Au collision at 25A GeV
UrQMD + GEANT + CbmRoot

- 10^5 - 10^7 Au+Au reactions/sec
- hit densities $10/\text{cm}^2/\text{event}$ (at STS-1)
- high hit rates 1-100 MHz/cm²
- fast and radiation hard detectors
- free-streaming readout electronics
- online event selection
- high precision vertex reconstruction
- identification of leptons and hadrons

700 π , 160 p, 53 K, 32 Λ , 27 K_S^0 , ~ 1 Ξ^- , 0.022 Ω^-

Development of CBM - examples of progress

The core detectors: Silicon Tracking System and Micro Vertex Detector

- 8 low-mass tracking stations
- 4 m² of silicon microstrip detectors
- layout optimized for efficient track reconstruction and high momentum resolution.
- 2 ultra-thin stations
- CMOS monolithic active pixel sensors
- layout optimized for extremely low mass and highest space-point resolution

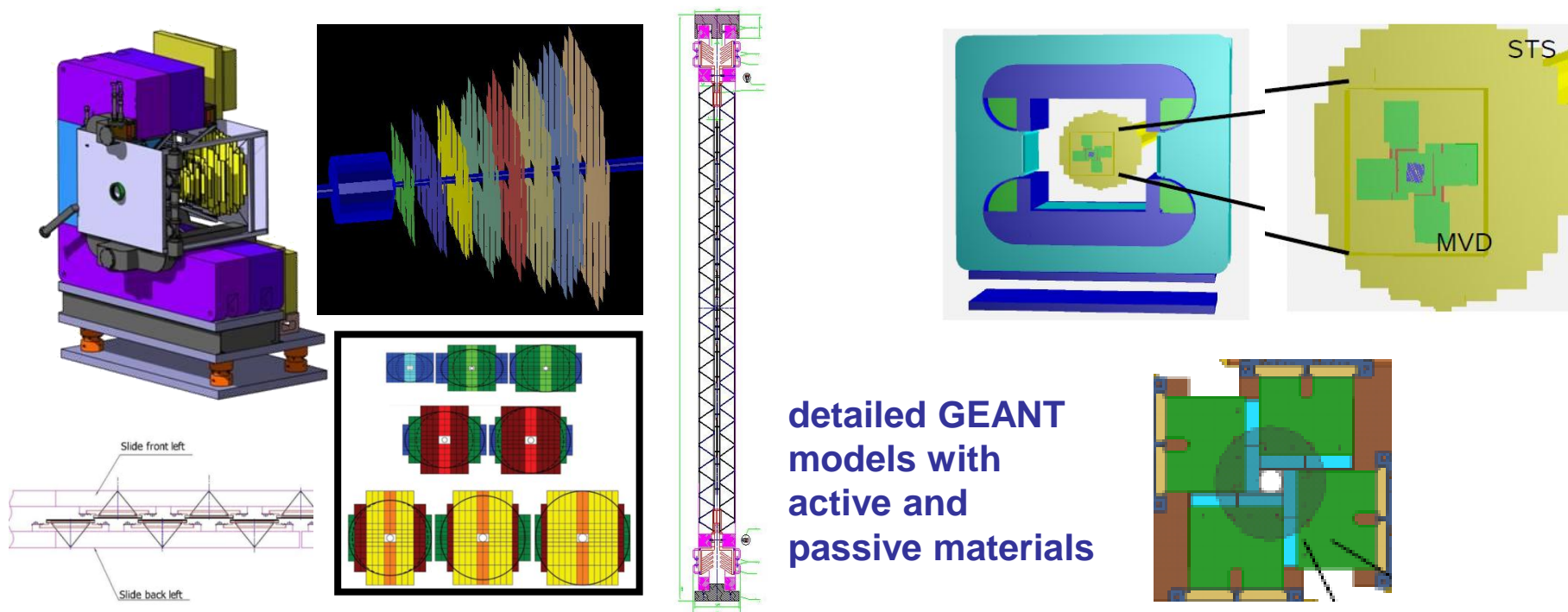

Silicon tracking performance

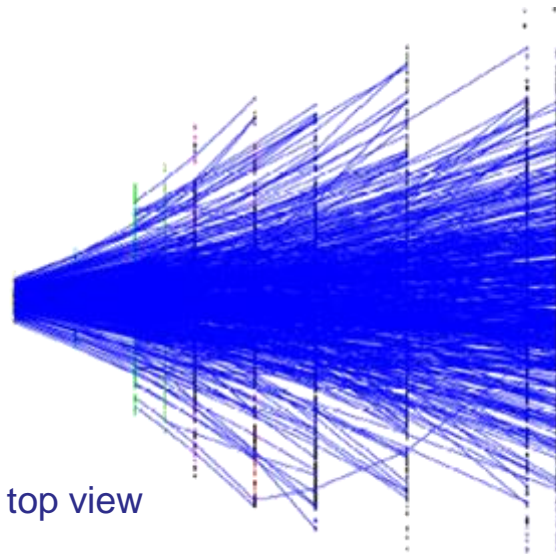

Au+Au collisions at
25 AGeV (UrQMD)

reconstruction with a
Cellular Automaton and
Kalman Filter

2500 min. bias events/s
80-core server with
4 Intel E7-4860 processors

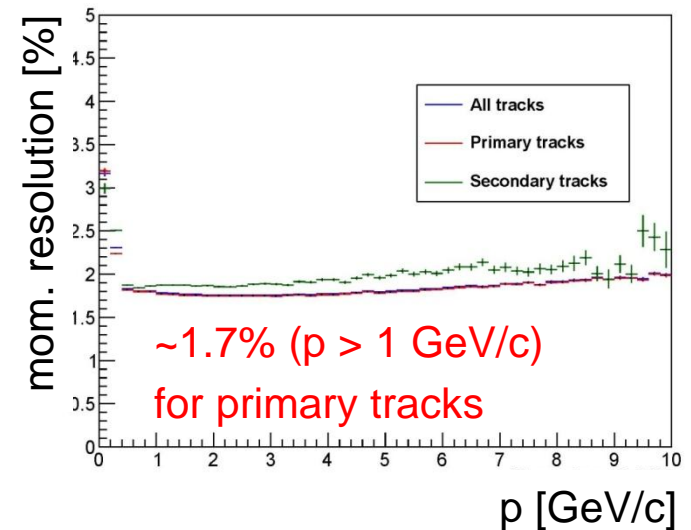
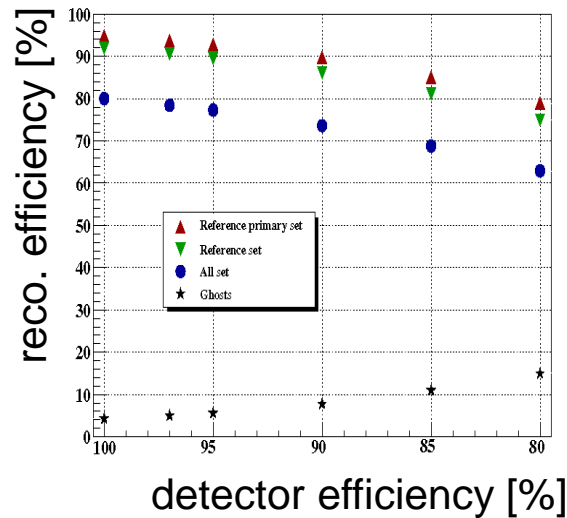
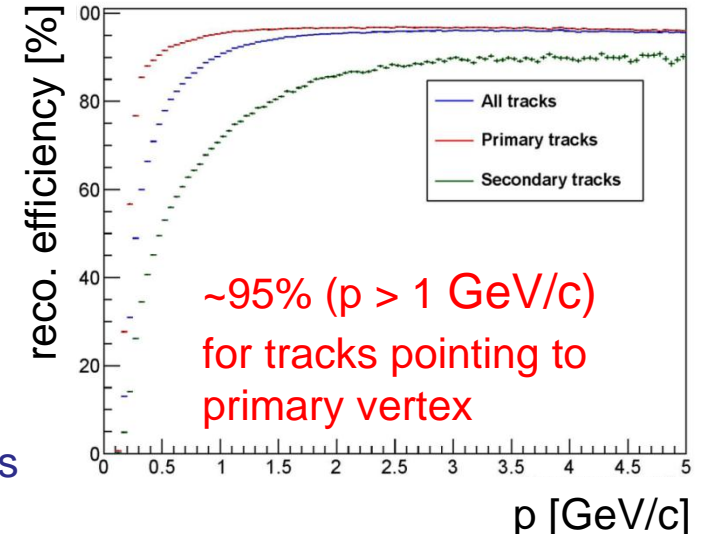
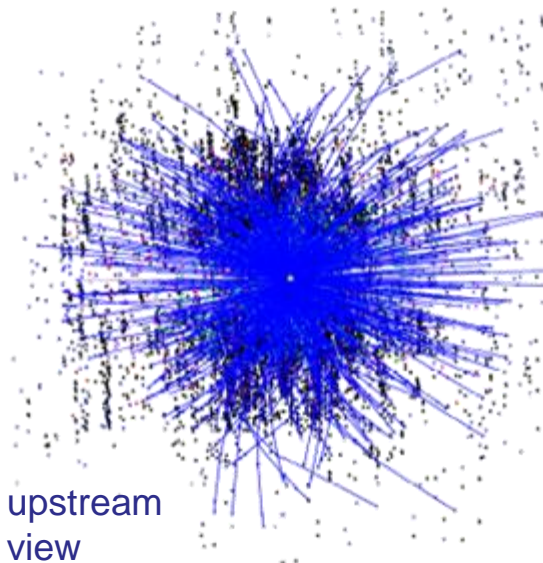

Novel data acquisition architecture

On-line event determination and event evaluation from free-streaming data.

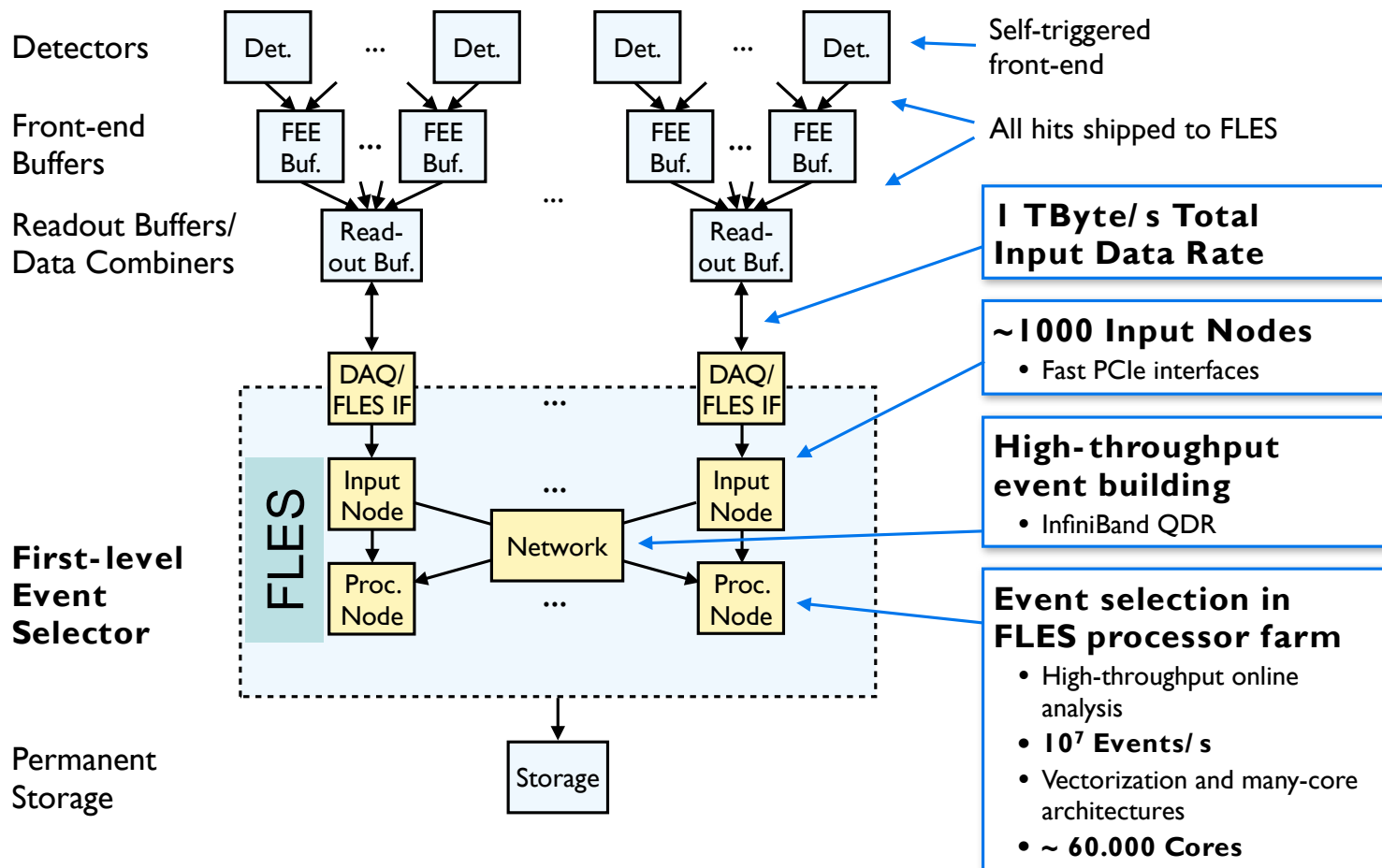

Computing centers

Prototype First Level Event Selector
for CBM: **LOEWE-CSC, Frankfurt**

800 nodes each with two 12-core
processors + one GPU

rank 22 in top-500 list of super-
computers



Prototype for a new
data center at GSI:
“Mini Cube”

with some 10,000
cores



GreenIT Cube

forthcoming FAIR
Tier-0 data center



Open charm reconstruction in Au+Au collisions at 25 AGeV

- STS: microstrip detectors ($8 \times 0.4\% X_0$)
- MVD: MAPS pixel sensors ($0.3\% X_0, 0.5\% X_0$)
- no K and π identification, proton rejection via TOF

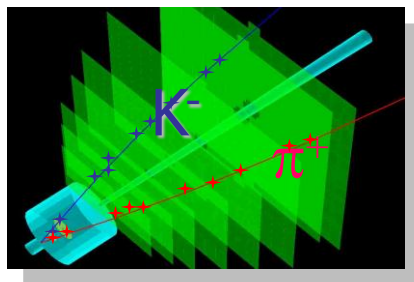

$D^0 \rightarrow K \pi, c\tau = 123 \mu\text{m}$

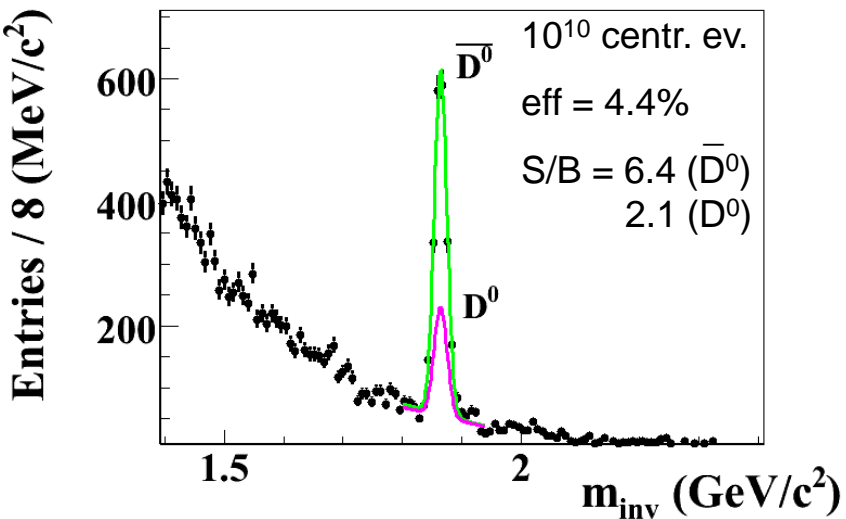

$D^\pm \rightarrow K \pi \pi, c\tau = 317 \mu\text{m}$

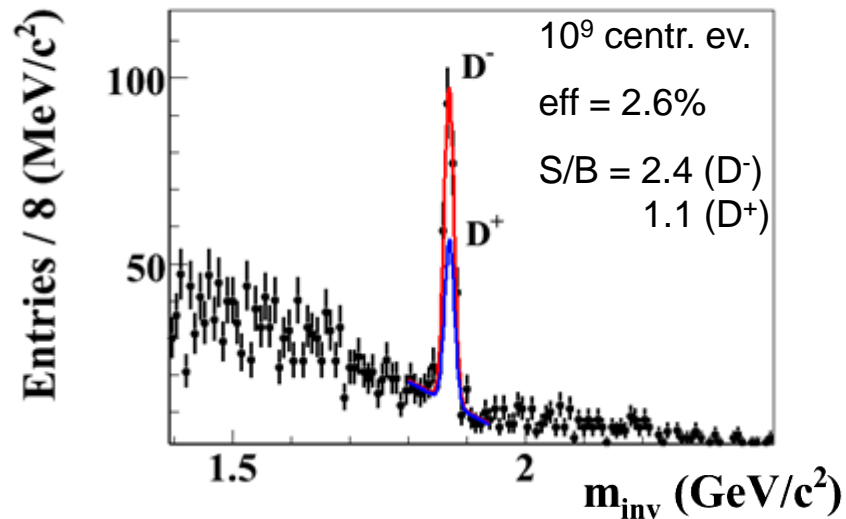

10 weeks data taking at 10^5 interactions/s (MVD limit)

~ 7k D^0 + 20k \bar{D}^0

and

~ 12k D^+ + 26k D^-

(based on HSD multiplicities)

Prototype STS and MVD components

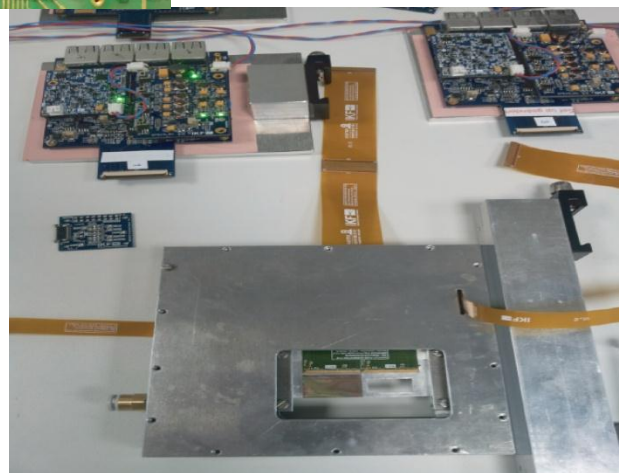
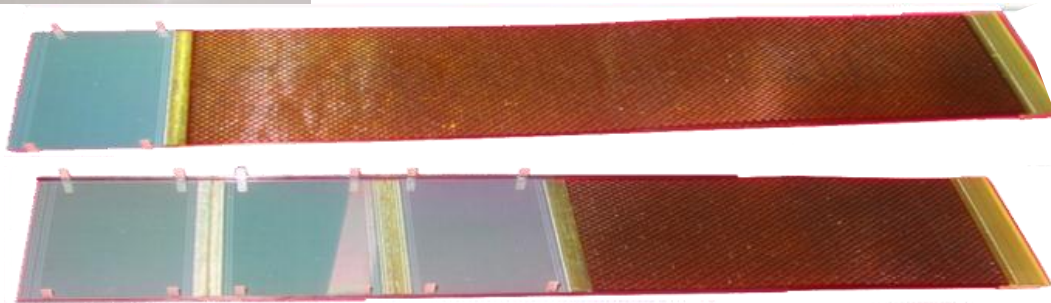
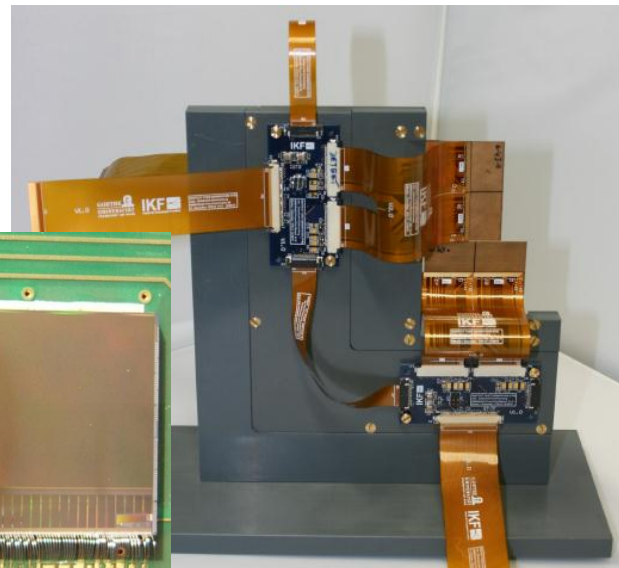
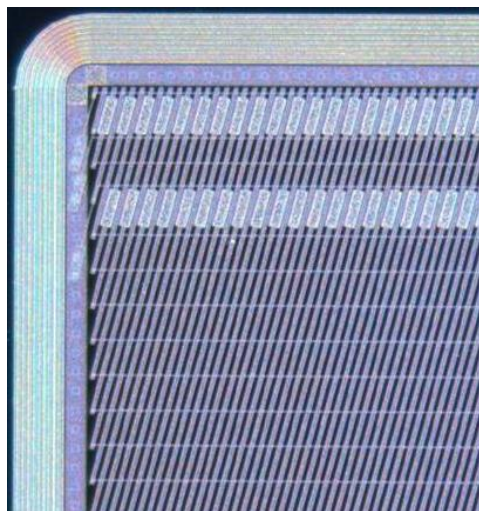
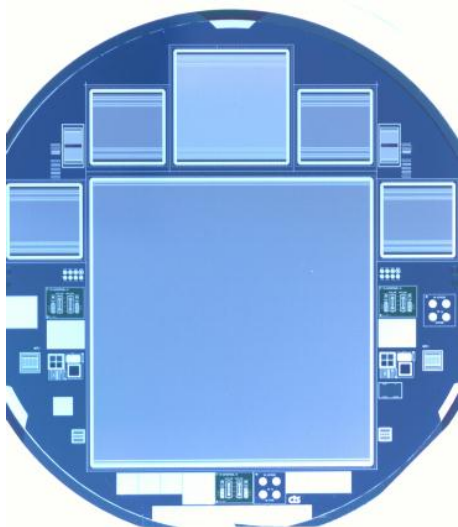

In-beam tests of prototype systems

silicon
microstrip
detectors

self-
triggering
front-end
electronics

DAQ

DCS

online
monitoring

tracking

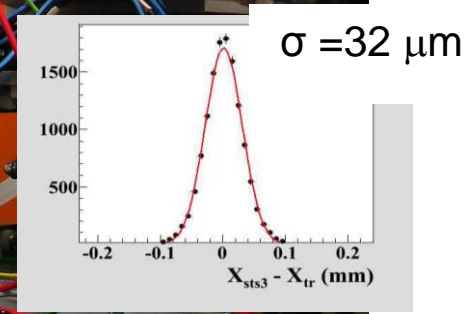
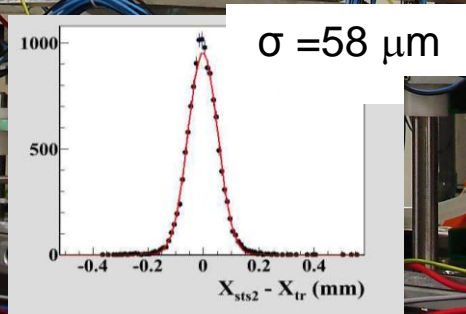
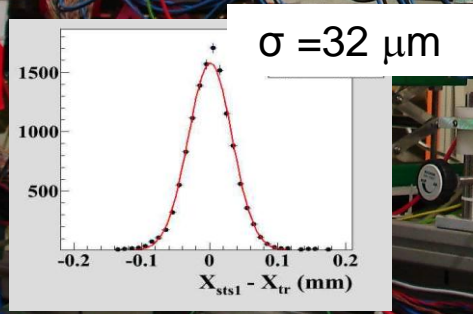
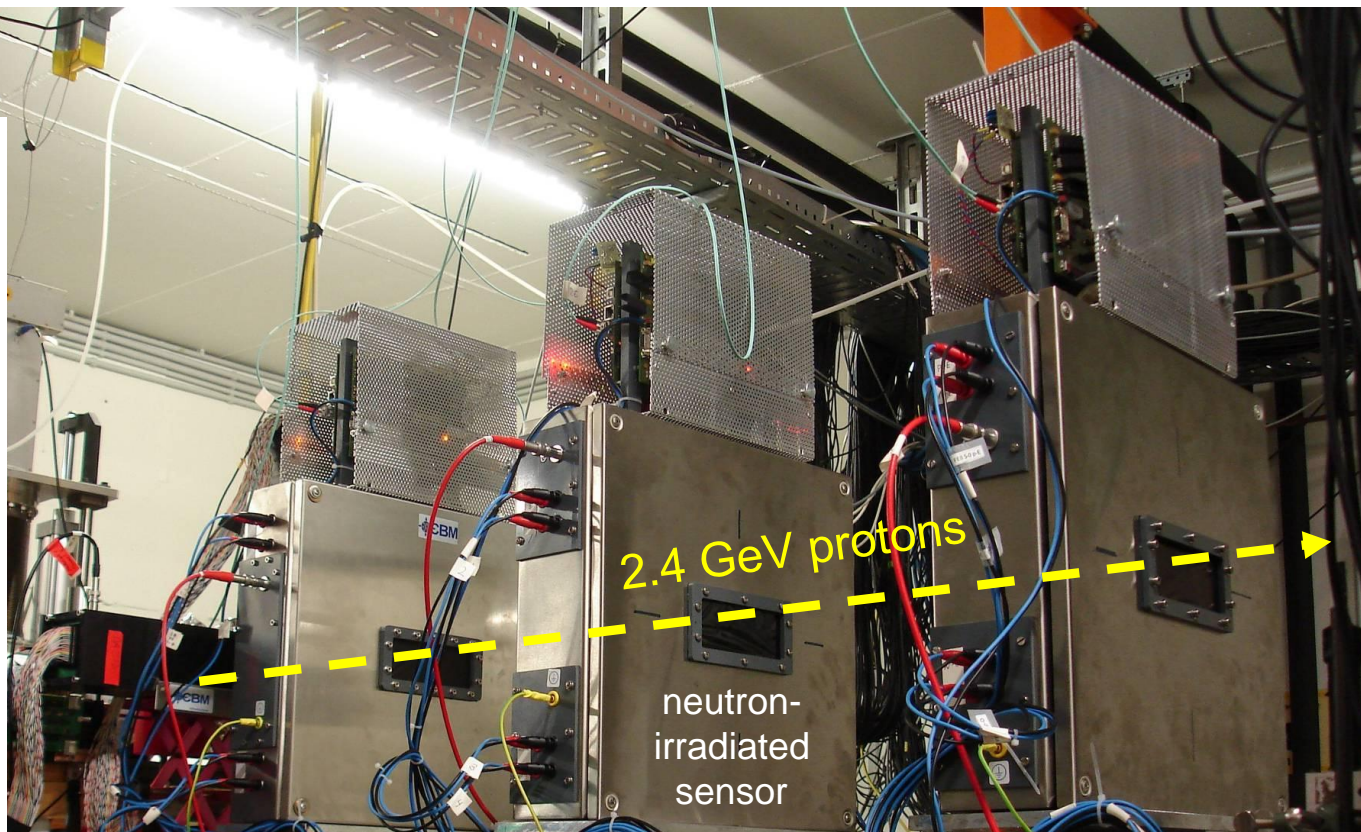

System engineering

- STS
- MVD
- beam pipe
- target

in **dipole magnet** gap:
 $1.4 \times 1.8 \times 1.0 \text{ m}^3$

thermal insulation,
windows

cooling

of electronics with
 CO_2 cooling
system

and of Si sensors
with dry gas

operation
temperature:

$\sim -5^\circ \text{C}$ to -10°C

electronics,
cooling pipes,
low voltage cables,
optical data links

power dissipation:

planned prototypes: 37 kW

optimized distribution: 27 kW

maintenance

Poster presentations on detector developments

- [13] The Micro-Vertex-Detector of the CBM-Experiment
T. Tischler (Frankfurt Univ.)

- [76] Two real-size high-rate MRPC modules for CBM-TOF
J. Wang (Tsinghua Univ.)

- [100] Development of the Silicon Tracking System for the Compressed Baryonic Matter (CBM) Experiment at FAIR
J. Eschke (GSI-FAIR)

- [260] The RICH detector for the Compressed Baryonic Matter experiment
J. Kopfer (Wuppertal Univ.)

Summary

- CBM Collaboration: 56 institutes, 455 members from 12 countries
- The CBM physics program is one of the four scientific pillars at FAIR
- FAIR construction has started
- CBM starts at SIS-100: physics program on nuclear equation-of-state, hadrons in dense matter, strangeness, heavy-flavor physics

Current CBM activities focus on:

- Pre-construction Memorandum of Understanding (signed)
- Prototyping of detector systems
- Online data processing
- Preparation of Technical Design Reports

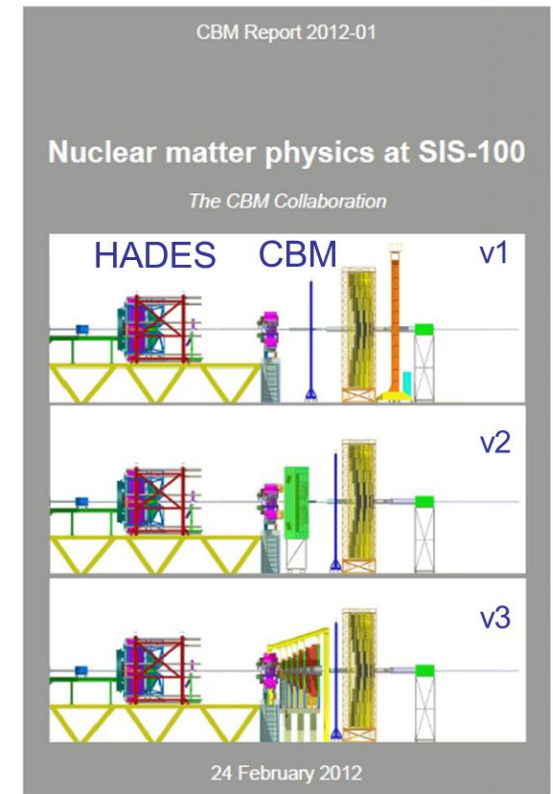

backup slides

Observables and physics at SIS-300

- **Particles containing charm quarks (D mesons and charmonium)**
→ early, dense phase of collision
- **Low-mass vector mesons decaying into dilepton pairs (ρ, ω, ϕ)**
→ hadron properties in the dense and hot fireball
- **Collective flow of identified hadrons**
→ information on the equation-of-state of dense matter
- **Kaons, hyperons and hadronic resonances**
→ strangeness sensitive to fireball evolution
- **Dynamical fluctuations of particle multiplicities and momenta**
→ sensitive to first order phase transition or the critical endpoint
- **Photons**
→ direct radiation from the early fireball
- **Two-particle correlations**
→ source size and time evolution of fireball + particle production

Observables and physics at SIS-100

- Nuclear equation-of-state, new forms of matter at high densities?

What are the properties and the degrees-of-freedom of nuclear matter at neutron star core densities?

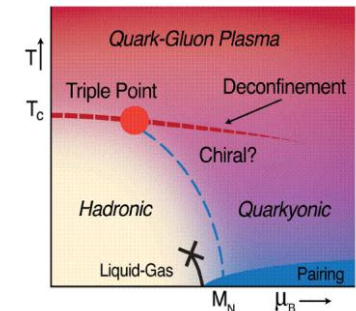
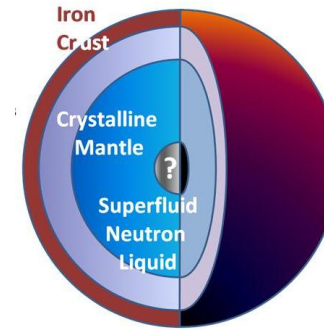

- Hadrons in dense matter:

What are the in-medium properties of hadrons?
Is chiral symmetry restored at very high baryon densities?

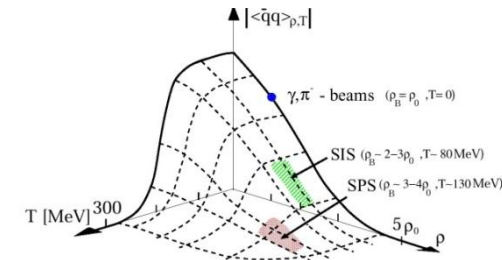

- Production of single and double hypernuclei

How far can we extend the third (strange) dimension of the nuclear chart?

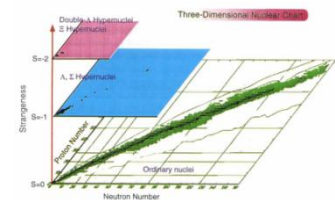

- Strange matter:

Does strange matter exist in the form of heavy multi-strange objects?

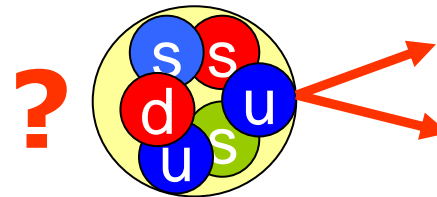

- Heavy flavor physics:

How is charm produced at low beam energies, and how does it propagate in cold nuclear matter?

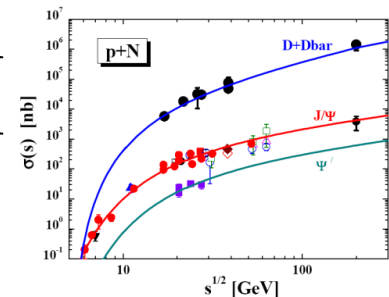

Observables and detector combinations at SIS-100

Observable	Detectors								
	HADES	CBM							
		Magnet +STS +DAQ +FLES	MVD	TOF	TRD 1	RICH	MuCh start	ECAL start	PSD
hadrons, hyperons, dileptons in Ni+Ni < 8A GeV	X								
hadrons, hyperons, hyper nuclei, Au+Au < 11A GeV		X		X	X				X
dileptons , Au+Au 11A GeV		X	X	X	X	X			X
D mesons, p+A < 30 GeV		X	X	X	X				
charmonium, p+A < 30 GeV, Au+Au < 11A GeV		X		X	X		X		X
photons (incl. π^0 and η)		X						X	X

STS: Silicon Tracking System

TRD: start version as tracker (1 station of 3)

TOF: Time-of-Flight Detector (RPC)

PSD: Projectile Spectator Detector

MVD: Micro-Vertex Detector

MuCh: start version Myon Detector (2 stations of 5)

DAQ/: Data Acquisition System & First Level Event Selection
(start version)

ECAL: Electromagnetic Calorimeter (start version)

Costs of FAIR start version

Accelerators incl. personell, modules 0 – 3	502 M€
Construction, modules 0 - 3	400 M€
FAIR share in experiments (excluding Super-FRS)*	78 M€
FAIR GmbH personell & running costs (until 2018)	47 M€
Sum Modules 0 - 3	1027 M€

in 2005 €
(inflation until 2018 ca. +50%)

* Total costs of experiments (excl. Super-FRS):
ca. 210 M€ (2005) = 315 M€ (2018)

Costs of CBM in M€ (2009)

Project	Costs full version	Costs start version
MVD	2.1	2.1
STS	11.5	11.5
TRD*	9.6	4.0
RICH	5.6	5.6
TOF	6.8	6.8
DAQ*	3.9	3.0
FLES*	6.0	3.0
Magnet	4.3	4.3
MuCh*	10.6	4.0
PSD	1.0	1.0
Infrastr.	4.2	4.2
ECAL*	10.6	3.0
Sum in 2009 €	76.4	52.5

TDR*, DAQ*, FLES*, MuCh*, ECAL*:
reduced for CBM start version 2018

Time lines for CBM subsystems

	2012	2013	2014	2015	2016	2017	2018
MVD	R&D,	proto- typing	TDR, production			installation, commissioning	
STS	R&D, note, review	TDR, preseries production		production, quality assurance		“	
TRD	R&D, TDR		production			“	
RICH	prototypes, TDR		production			“	
MuCh	R&D, TDR			production		“	
TOF	R&D, TDR		pre-series production	production		“	
ECAL	R&D, TDR			production		“	
PSD	R&D, TDR			production		“	
DAQ	R&D, TDR		production			“	
FLES	R&D, prototypes				TDR	“	