

LHC Days in Split



LHC Days in Split

Status

Julien Cogan (CPPM) on behalf of the LHCb Collaboration

LHCb Status

- ❖ Setting the scene
- ❖ Detector performances
- ❖ Operations

LHCb : a dedicated flavour physics experiment at LHC

ATLAS & CMS search for direct production of new states

LHCb designed to see their *indirect* effect on **charm & beauty** decays via *virtual* production in loop diagrams

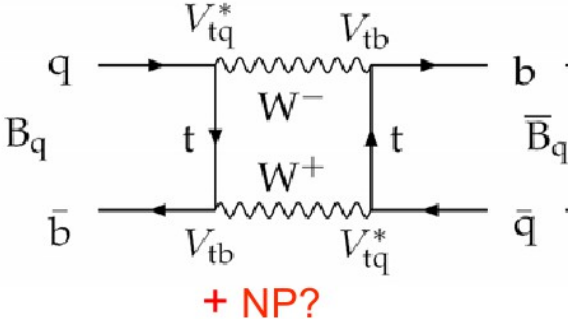
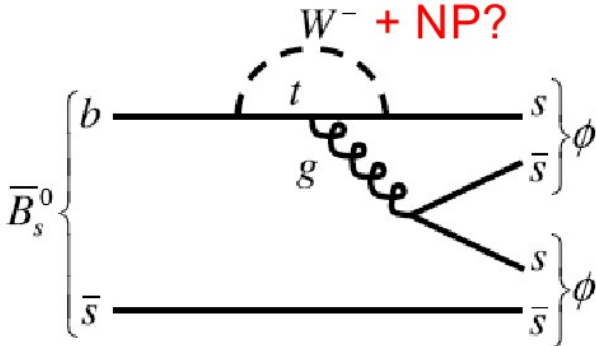
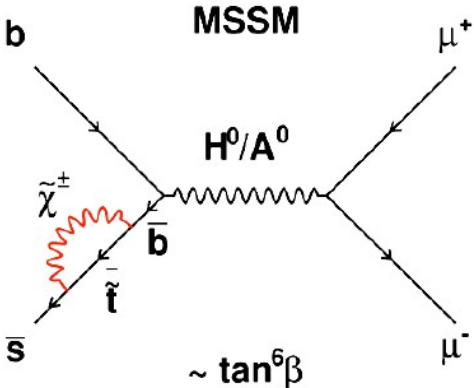

Key topics in LHCb :

- **CP violation** : check whether it is due to a single phase in the quark mixing (CKM) matrix, as in the Standard Model
- **Rare decays** : FCNC decays (e.g. $B_s \rightarrow \mu^+\mu^-$) are strongly suppressed in the Standard Model, may be enhanced by new physics processes

Beauty and Charm production at LHC

LHC is a Flavor Factory, @ 7 TeV :

- $\sigma(pp \rightarrow c\bar{c} X) = \sim 6 \text{ mb}$ [LHCb-CONF-2010-013]
- $\sigma(pp \rightarrow b\bar{b} X) = \sim 0.3 \text{ mb}$ [PLB 694 (2010) 209]
- B factories : $\sigma(e^+e^- \rightarrow b\bar{b})@Y(4S) = \sim 1 \text{ nb}$

Challenging background condition :

- $\sigma(pp \rightarrow X)_{inel} = 60 \text{ mb}$ [JINST 7 (2012) P01010]

All B hadron species are produced cf. P. Bobovici's talk

- New states discovered, e.g. $\Lambda_b^*(5912/5920)$ orbitally-excited states [arXiv:1205.3452v1]
- New decay mode discovered, e.g. $B_c^+ \rightarrow J/\Psi \pi^+\pi^-\pi^+$ [PRL 108, 2012, p. 251802]
- B_s is rich and little explored

bb/cc pairs are produced predominantly in the forward or backward directions

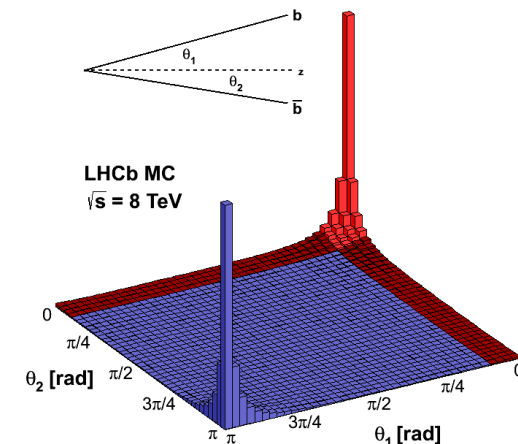
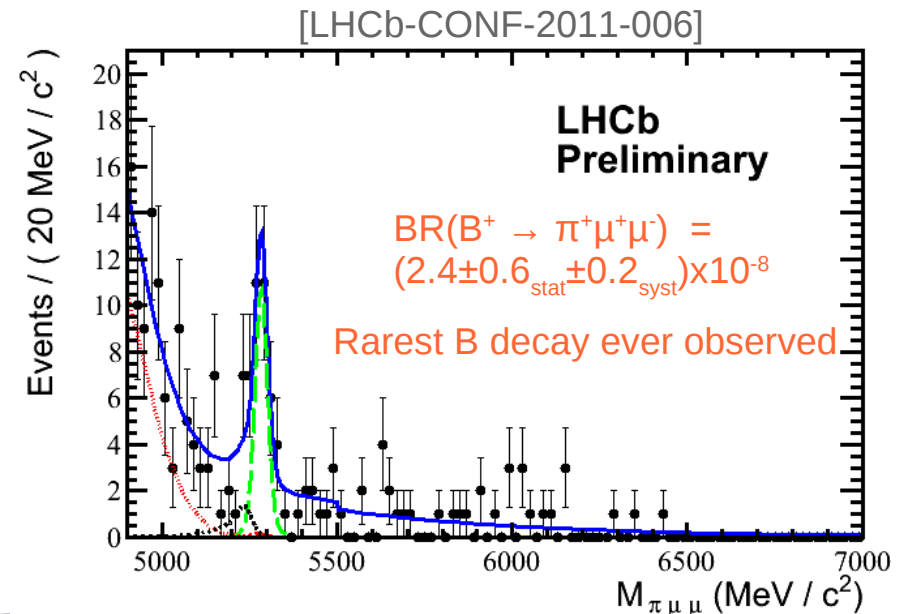
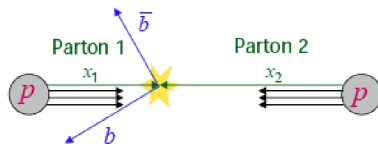

The LHCb Collaboration

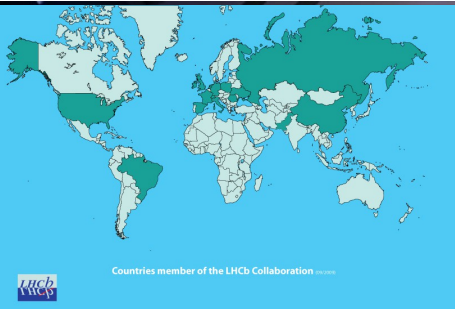

822 members - 60 institutes - 16 countries

7/09/2012



LHCb : a forward spectrometer

B forward-peaked production



LHCb is a forward spectrometer

(operating in collider mode)

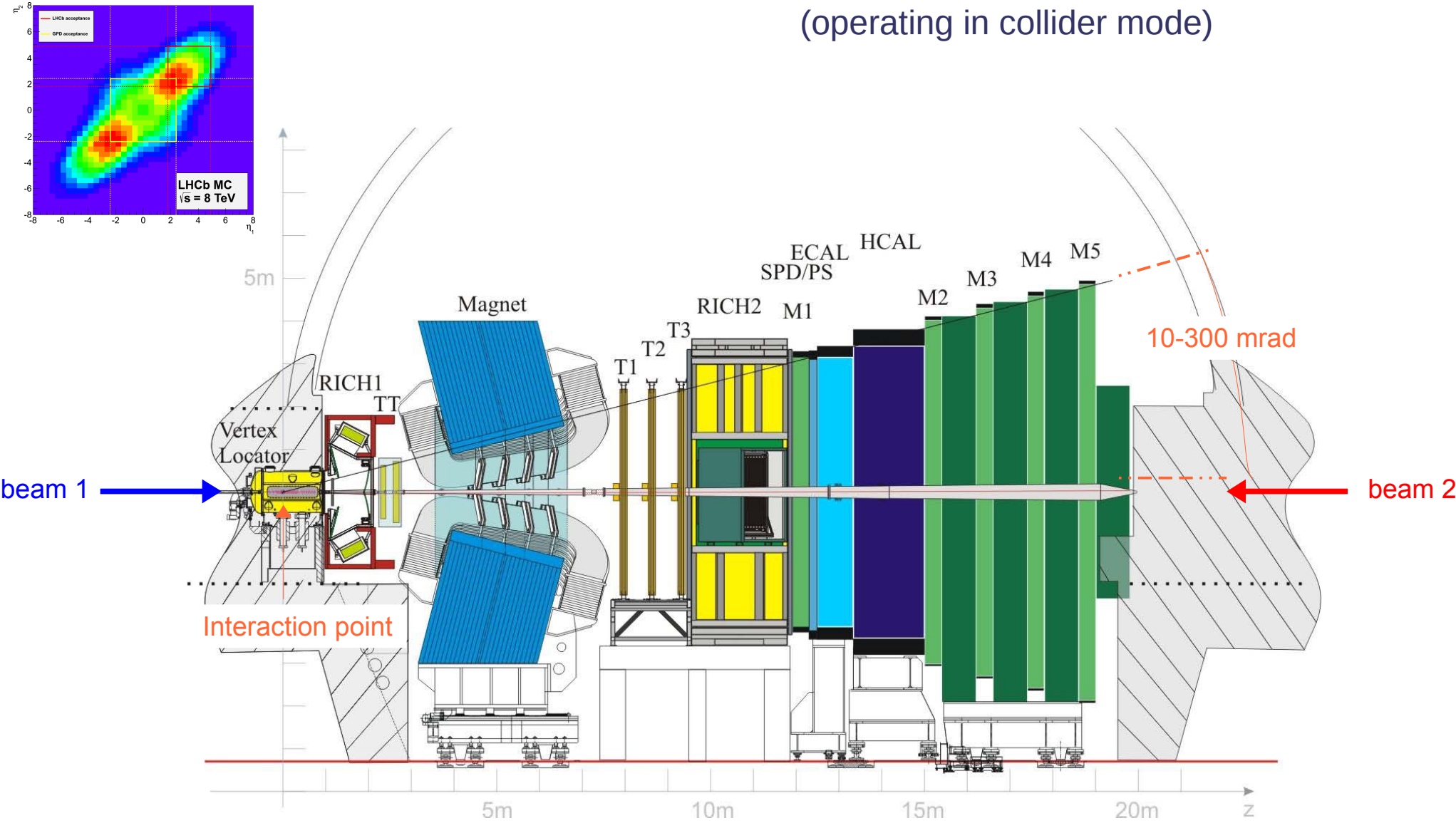

LHCb : a forward spectrometer

With unique rapidity coverage at LHC

→ complementary measurements

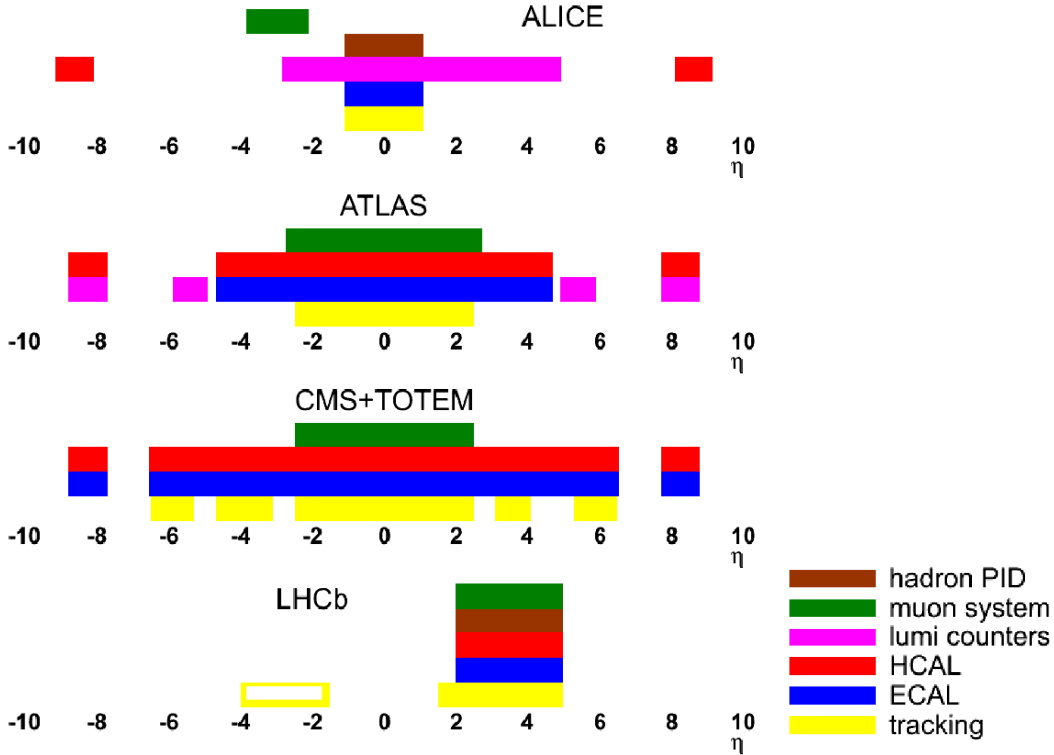

- LHCb acceptance : $2 < \eta < 5$
- fully covered by tracking and PID

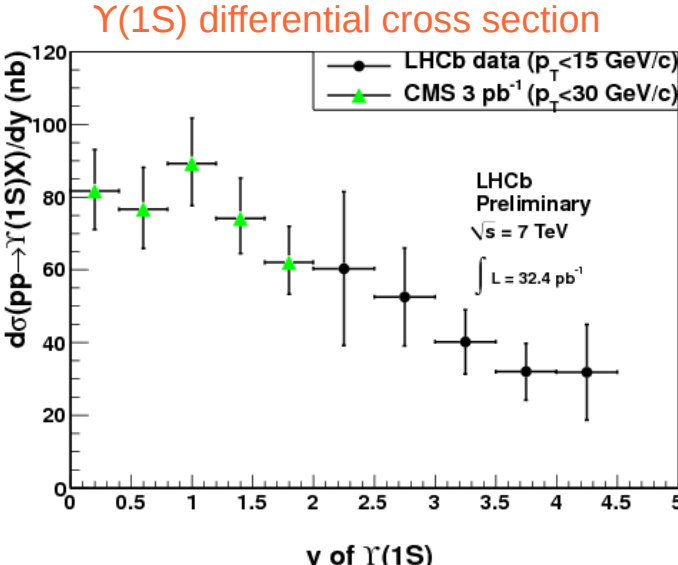
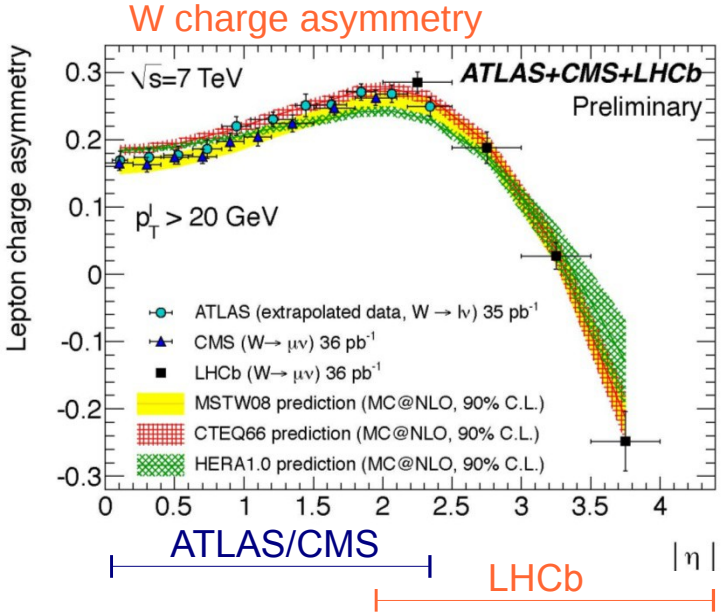
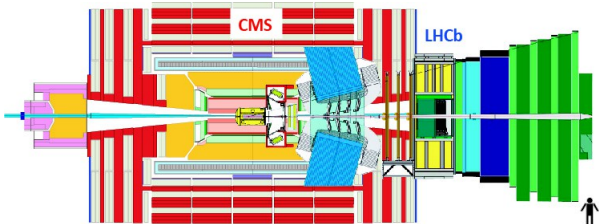

LHCb : a forward spectrometer optimised for heavy flavors

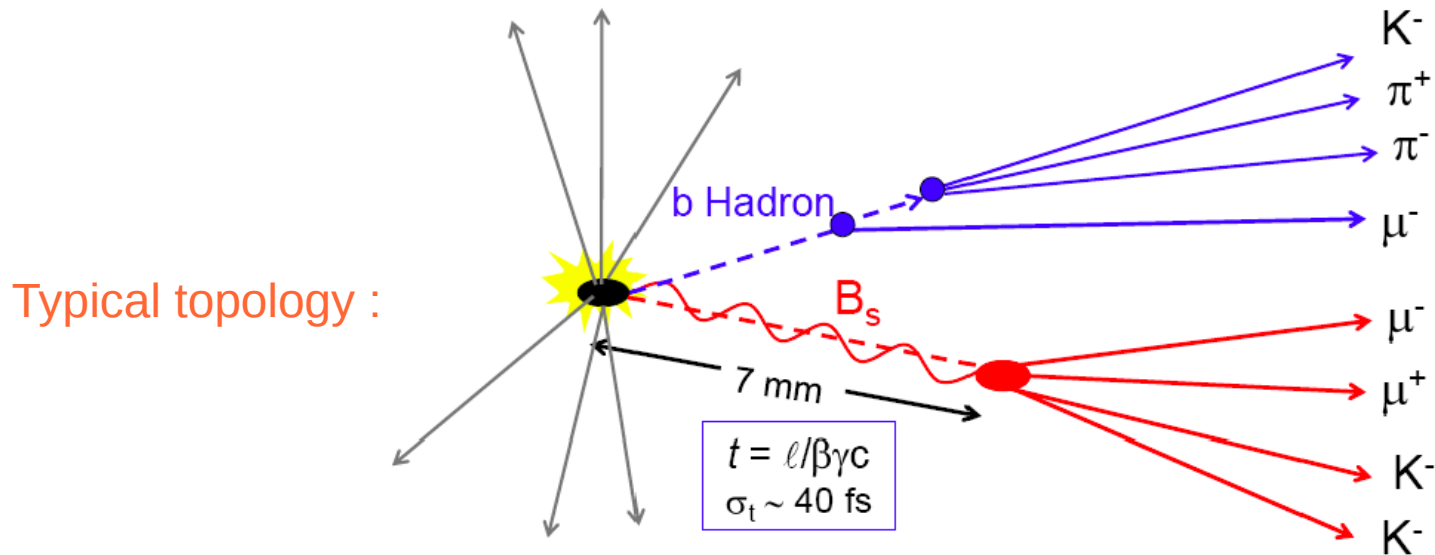

Key features :

- Resolve fast B_s oscillation
 - excellent vertex resolution
- Background reduction :
 - very good impact parameter resolution
 - good mass resolution
 - good particle identification (K/π)
- Collect high statistics :
 - efficient trigger for both hadronic and leptonic final states

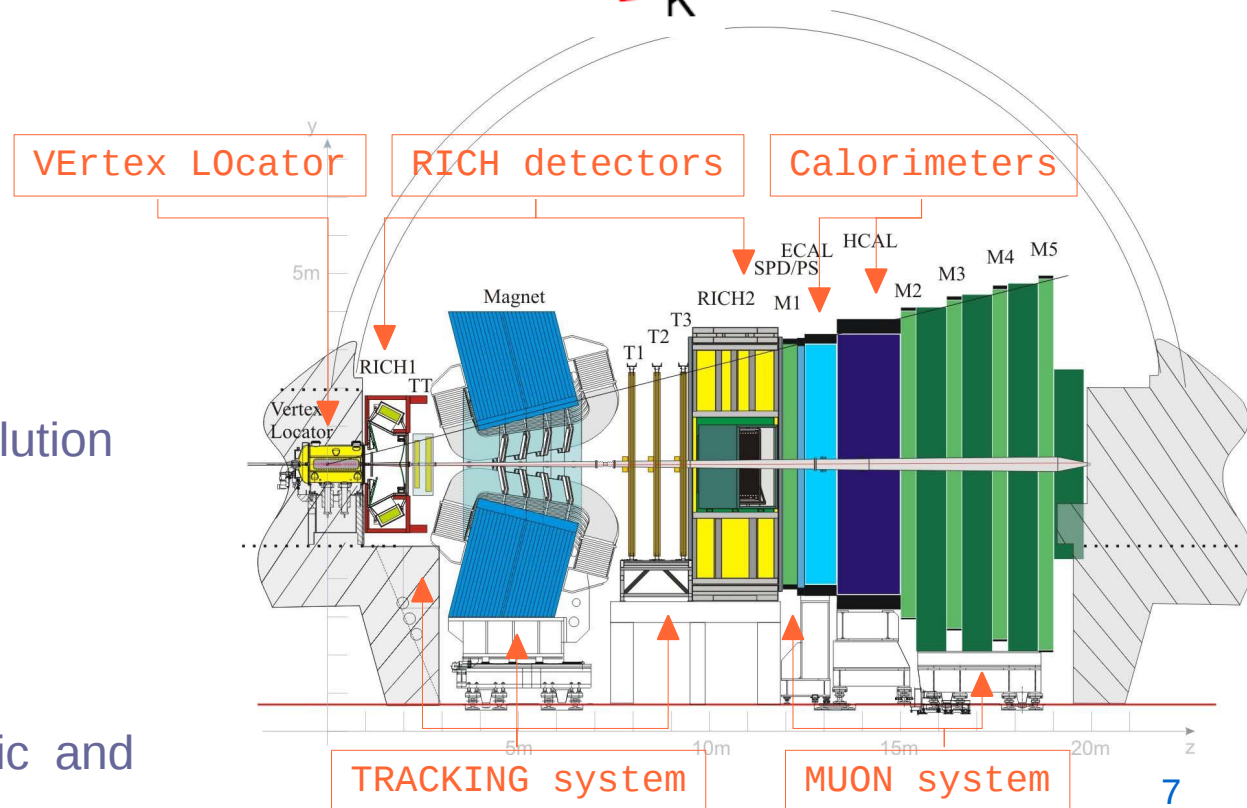

LHCb detector

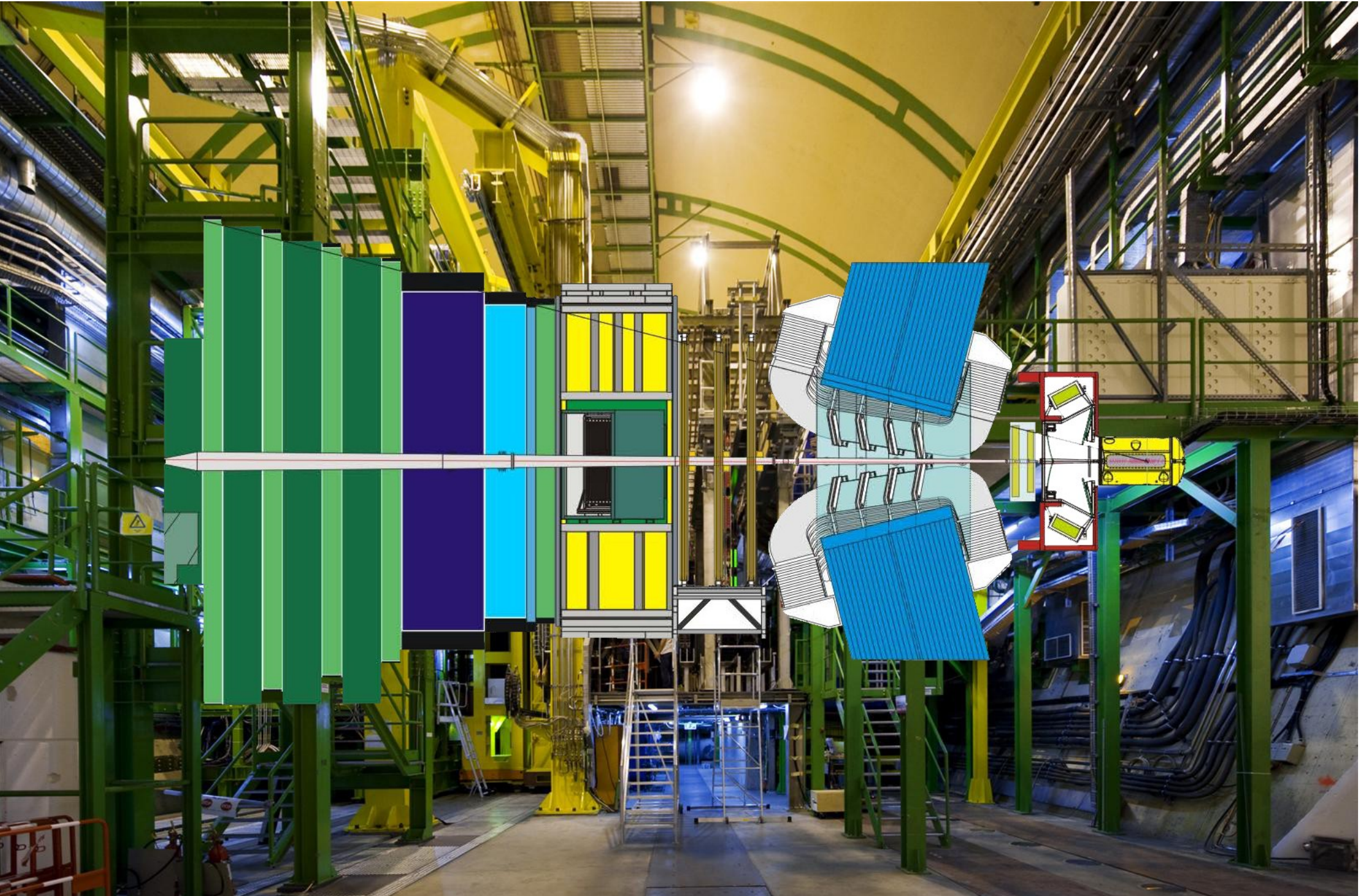

Vertex detection : the VErteX LOcator (VELO)

Reconstruction of primary and decay vertices, track seeds, + trigger input

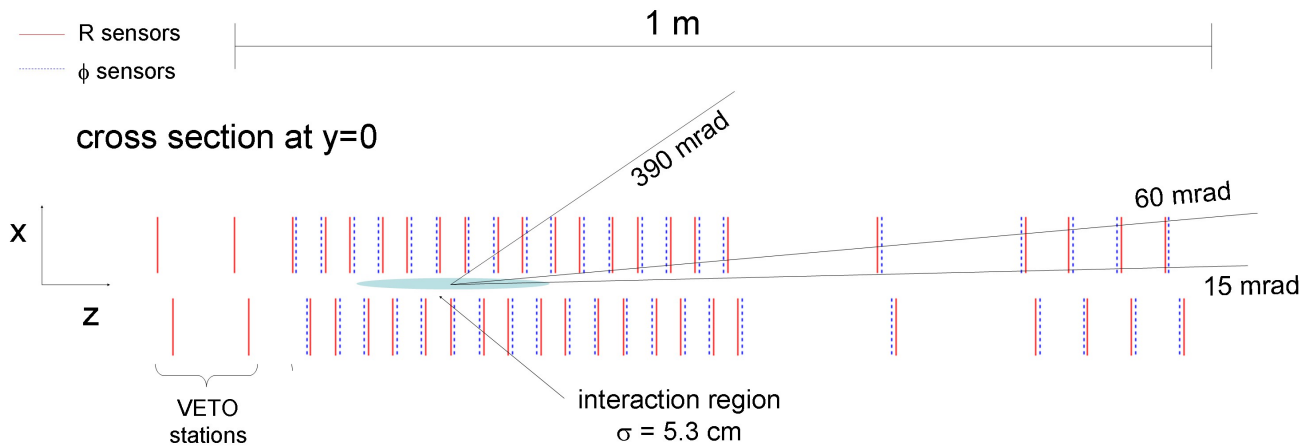

The VELO seen by the LHC beams

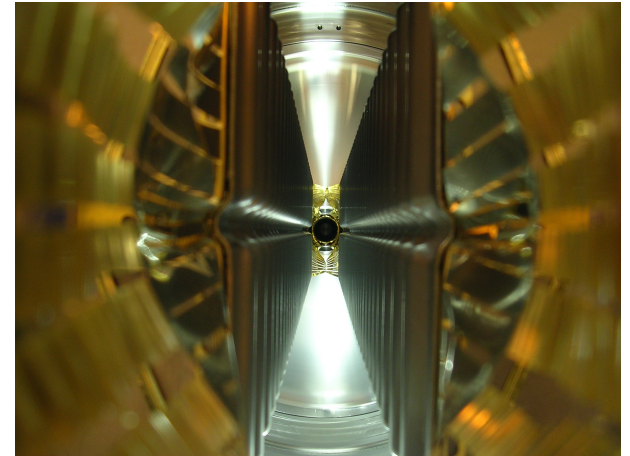

21 modules of R- Φ sensors

Movable device (retracted for safety during beam injection) :

- 35 mm from beam out of physics
- 8 mm from beam during physics

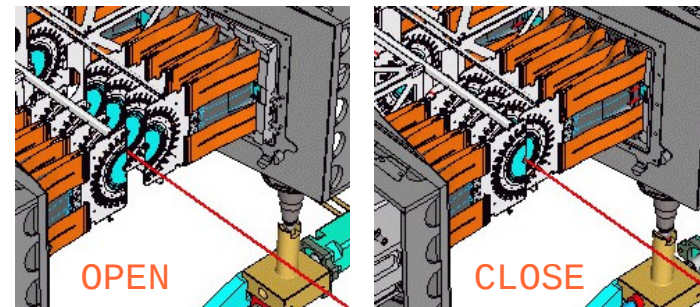

Vertex detection : performances

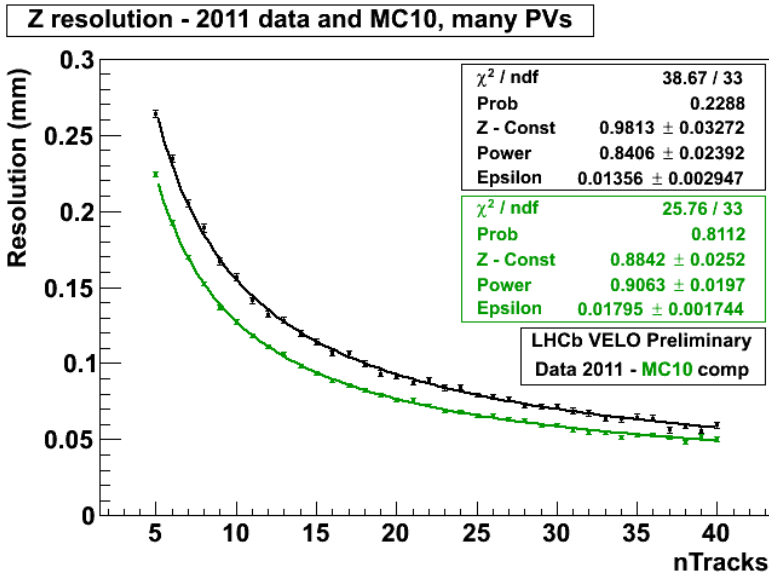

For 25 tracks : $\sigma_x \approx \sigma_y \approx 16 \mu\text{m}$, $\sigma_z \approx 76 \mu\text{m}$

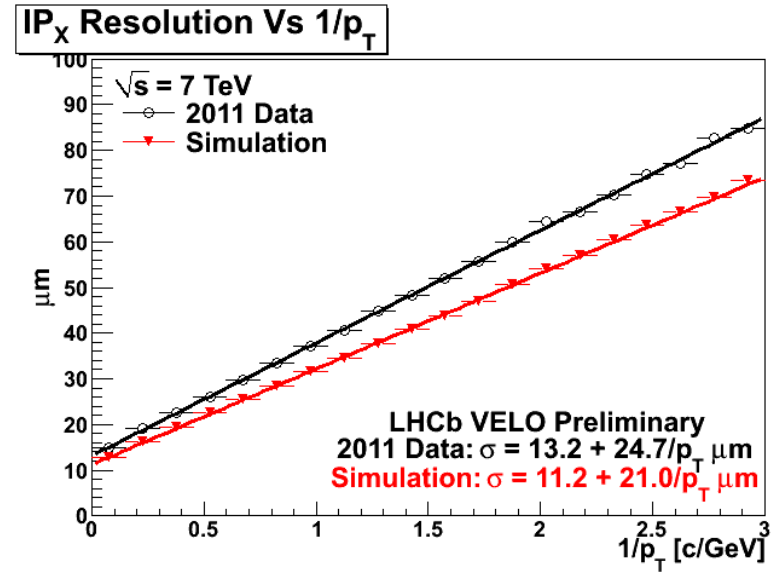

Impact parameter resolution
for high p_T track : $\sim 20 \mu\text{m}$

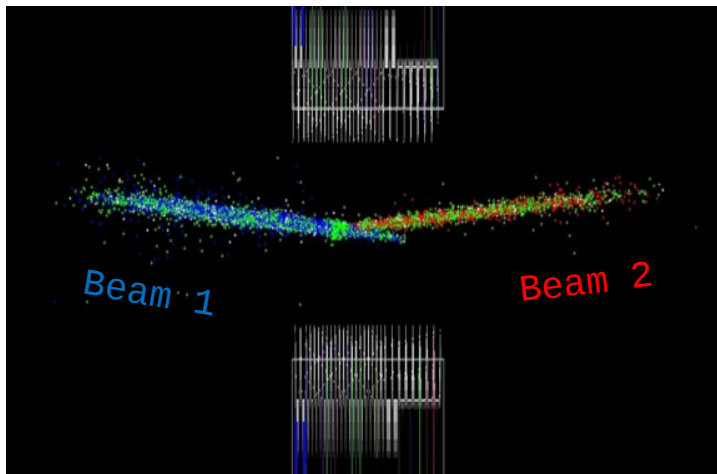

Reconstructed beam-gaz vertices
(used for luminosity measurement)

[PLB 693 69]

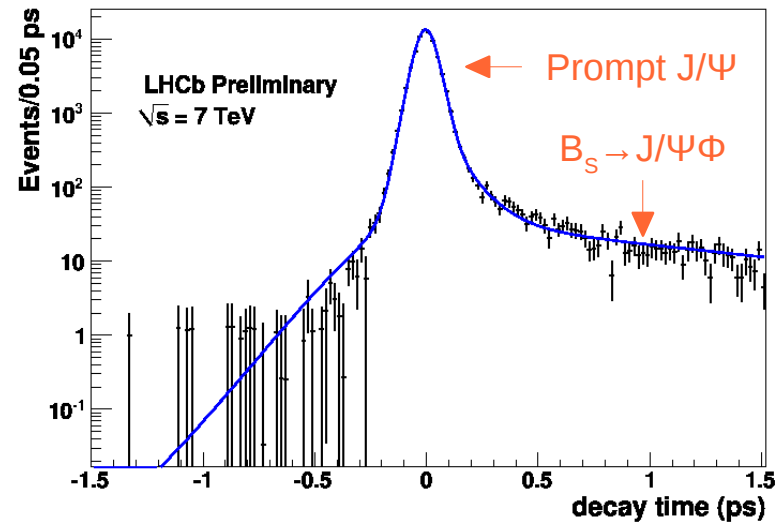

Proper time resolution : $\sigma_t = \sim 45 \text{ fs}$
(cf. $\lambda = 2\pi/\Delta m_s \sim 350 \text{ fs}$)

[CONF-2012-002]

The Tracking System

System :

- 1 tracking station before magnet (TT) :
 - 4 layers of Si-Strips sensors
- Magnet
 - $\int B dl = \sim 4 \text{ Tm}$; polarity switched regularly
- 3 tracking stations after magnet,
 - 4 layers each split into:
 - Inner Tracker (Si-sensors)
 - Outer Tracker (straw tube)

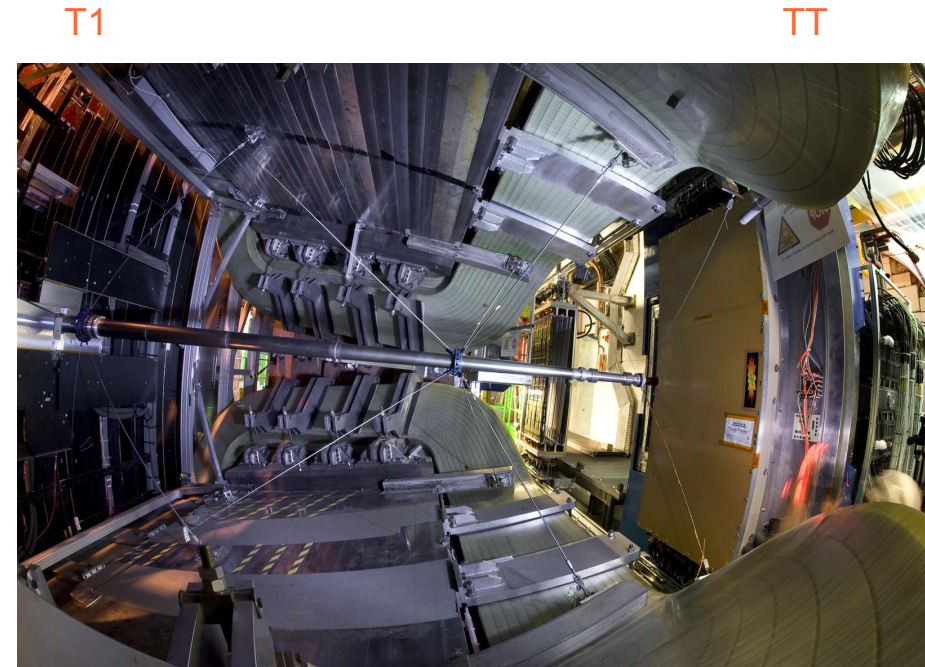

Track finding :

- Long tracks : high-momentum tracks traversing the full LHCb tracking setup
 - combine track seeds in VELO and T-stations and add TT hits
 - measured with highest precision
 - most numerous in the main LHCb acceptance

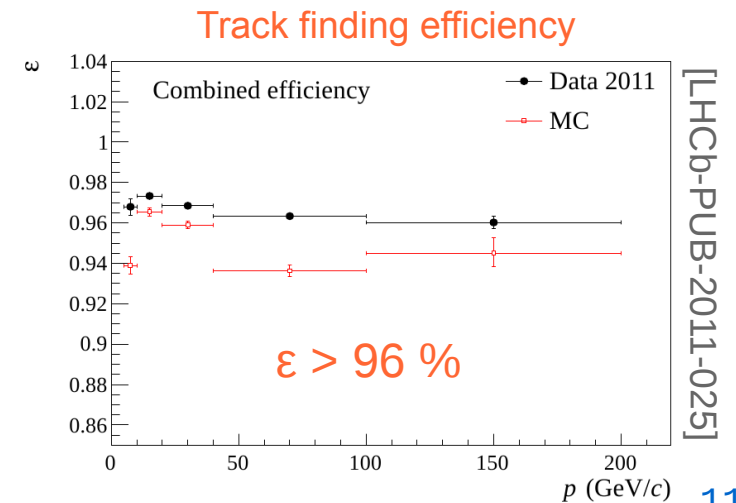

Tracking performances

Momentum resolution : $\sigma(p)/p = 0.4-0.6\%$ (5-100 GeV/c)

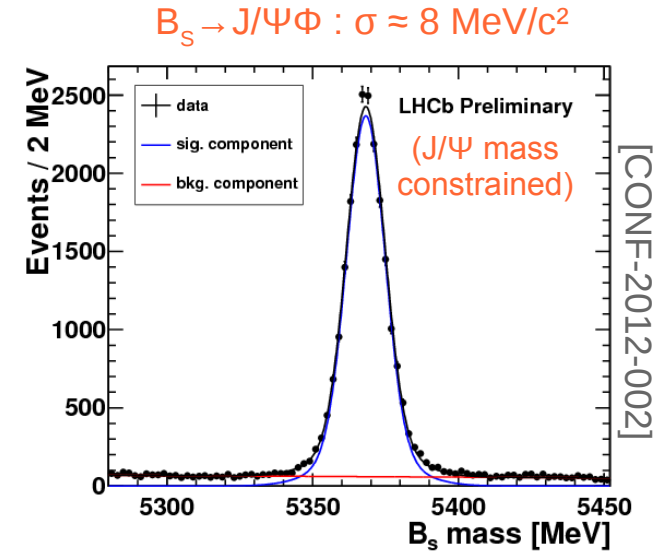
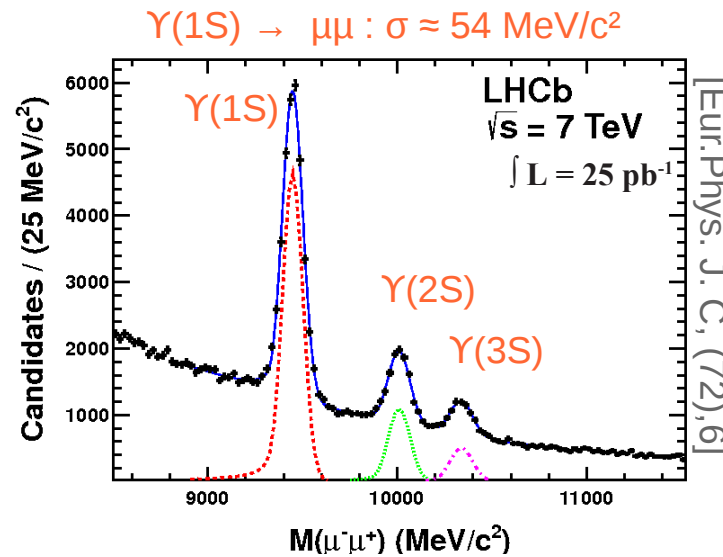
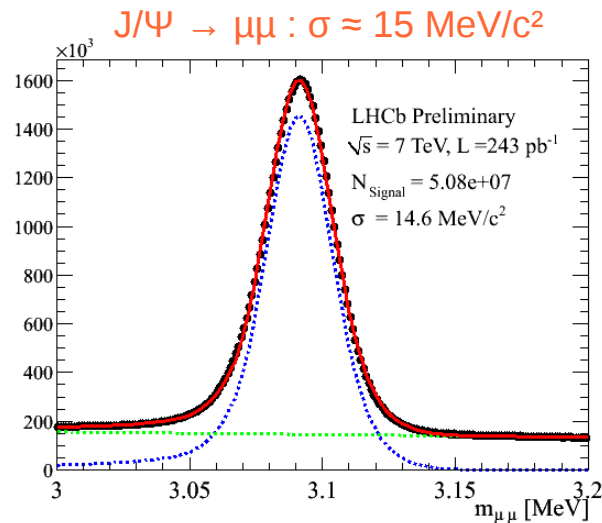

cf. [CMS DPS-2010-040] $\sim 16 \text{ MeV}/c^2$
 [ATLAS CONF-2011-050] $\sim 22 \text{ MeV}/c^2$

Momentum scale and detector alignment well controlled :

B hadron mass world's best measurements (2010 data only, 37pb⁻¹)

Quantity	LHCb measurement	Best previous measurement	PDG fit
$M(B^+)$	5279.38 ± 0.35	5279.10 ± 0.55	5279.17 ± 0.29
$M(B^0)$	5279.58 ± 0.32	5279.63 ± 0.62	5279.50 ± 0.30
$M(B_s^0)$	5366.90 ± 0.36	5366.01 ± 0.80	5366.3 ± 0.6
$M(\Lambda_b^0)$	5619.19 ± 0.76	5619.7 ± 1.7	—
$M(B^0) - M(B^+)$	0.20 ± 0.20	0.33 ± 0.06	0.33 ± 0.06
$M(B_s^0) - M(B^+)$	87.52 ± 0.32	—	—
$M(\Lambda_b^0) - M(B^+)$	339.81 ± 0.72	—	—

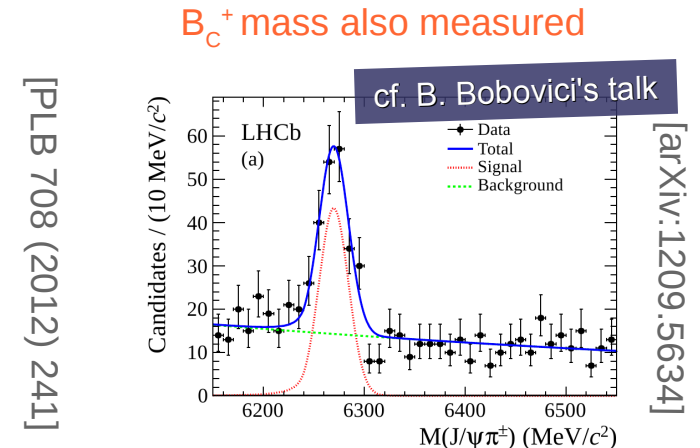

Particle identification : the RICH detectors

K/ π separation over the full 1-100 GeV/c range

The detectors :

- RICH1 :
 - full angular acceptance
 - covers low momentum range : 1-60 GeV/c
 - aerogel & C₄F₁₀ radiators
- RICH2 :
 - limited angular acceptance ($\sim \pm 15 \rightarrow \sim \pm 100$ mrad)
 - high momentum range : ~ 15 GeV/c - > 100 GeV/c
 - CF₄ radiator
- Hybrid Photon Detectors (HPDs)
 - 500 each with 1024 pixels
 - High efficiency, low noise

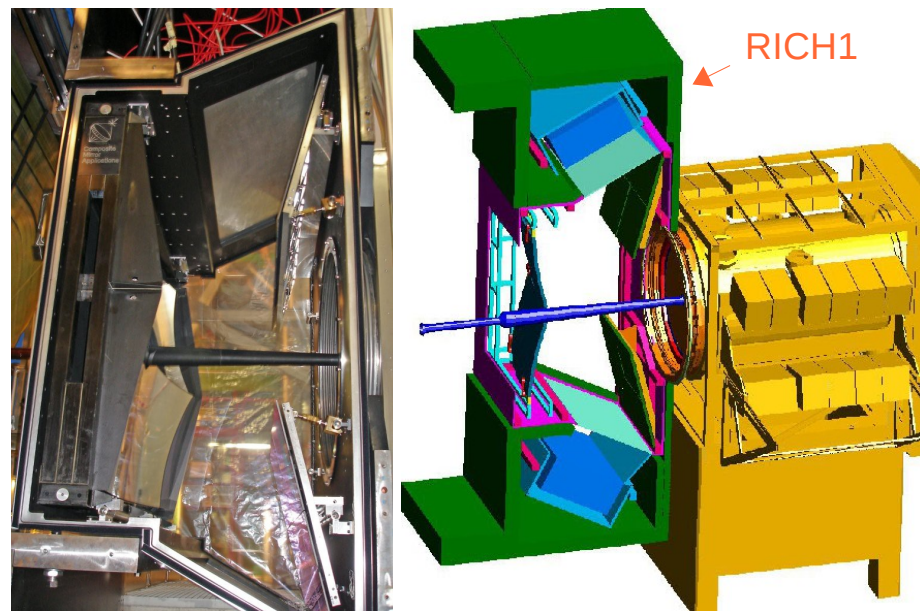

Performances

- $\epsilon \approx 95\%$ for 5% π -K misID probability
- performances well described by simulation

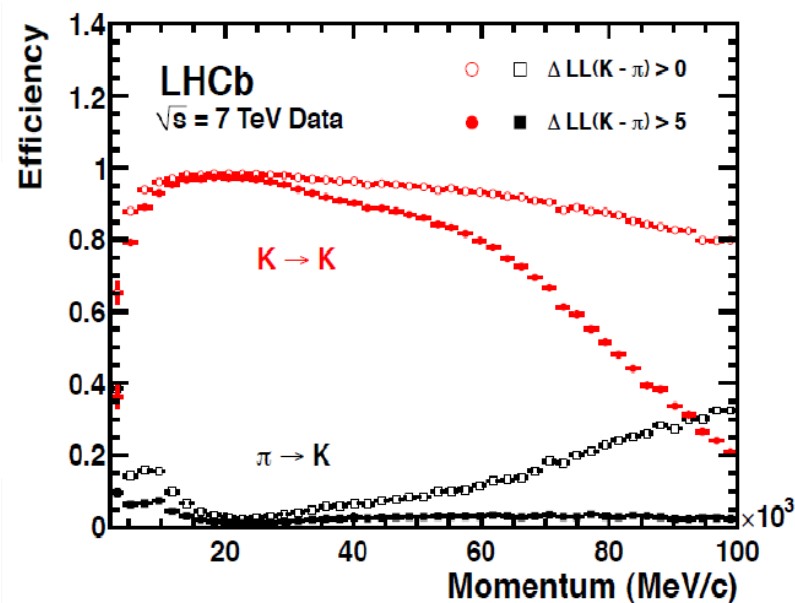

Particle identification : illustration of K- π separation

cf. C. Fitzpatrick 's talk

Charmless B decays : sensitive probes of CKM matrix

Plot with $\pi\pi$ hypothesis - No RICH

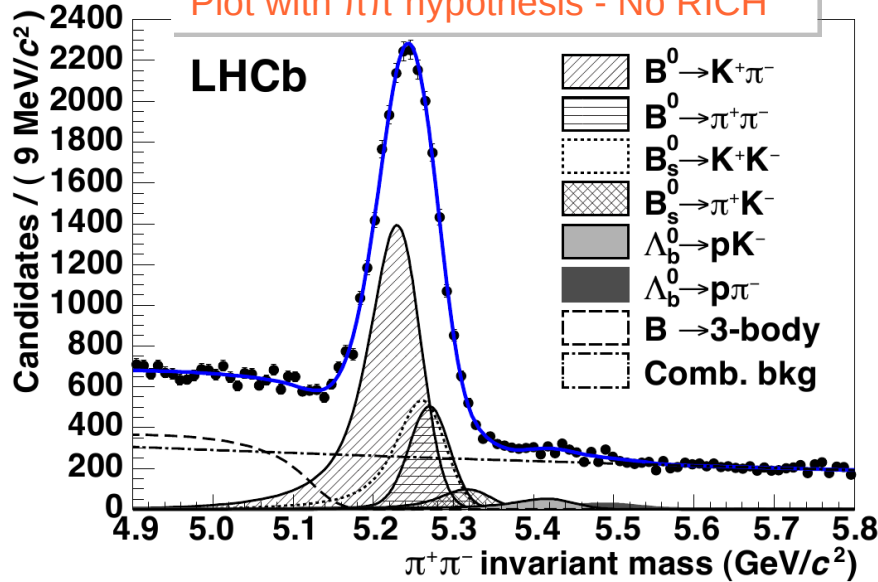

Deploy RICH to isolate each mode

$K\pi$

$\pi\pi$

KK

$\rho\pi$

ρK

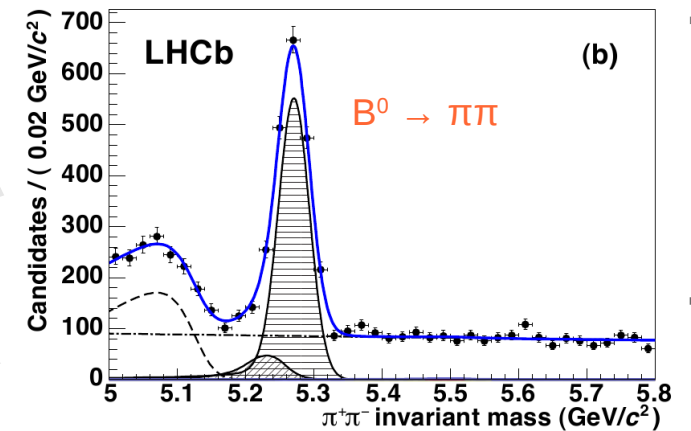
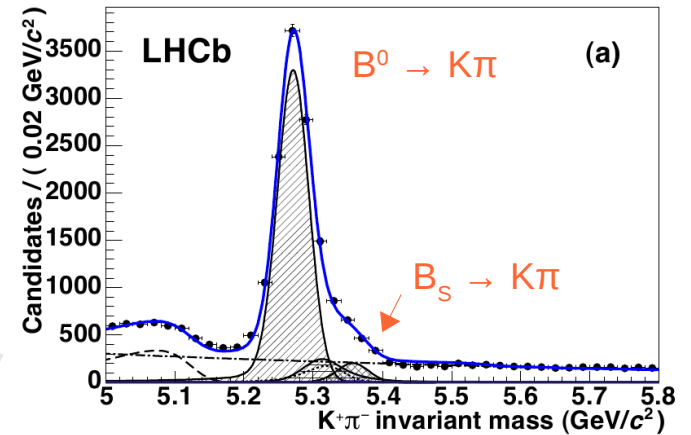

[arXiv:1206.2794]

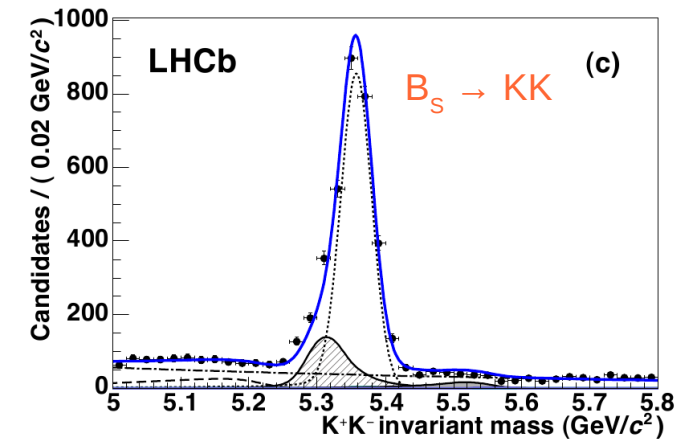
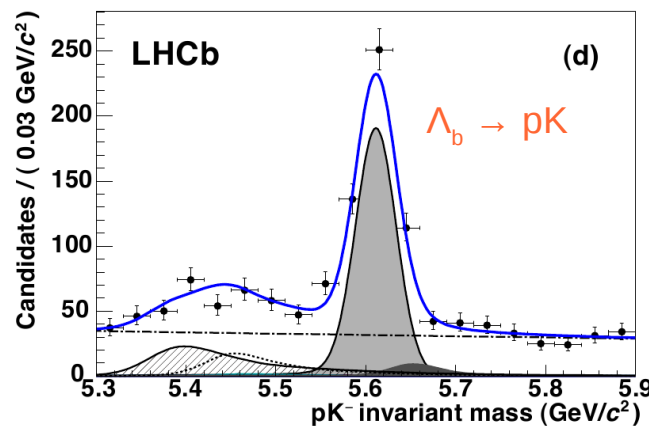
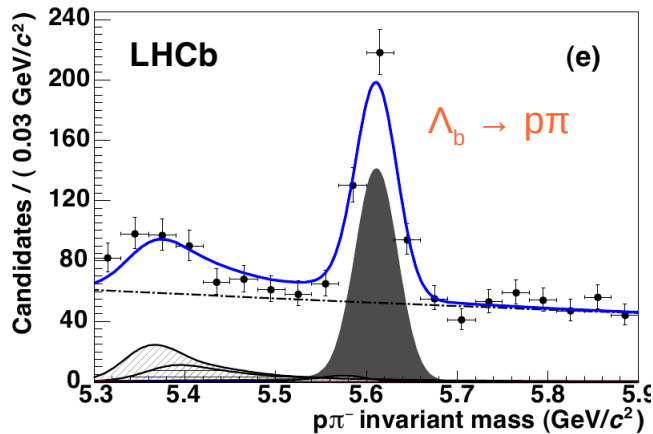

Particle identification : the calorimeters

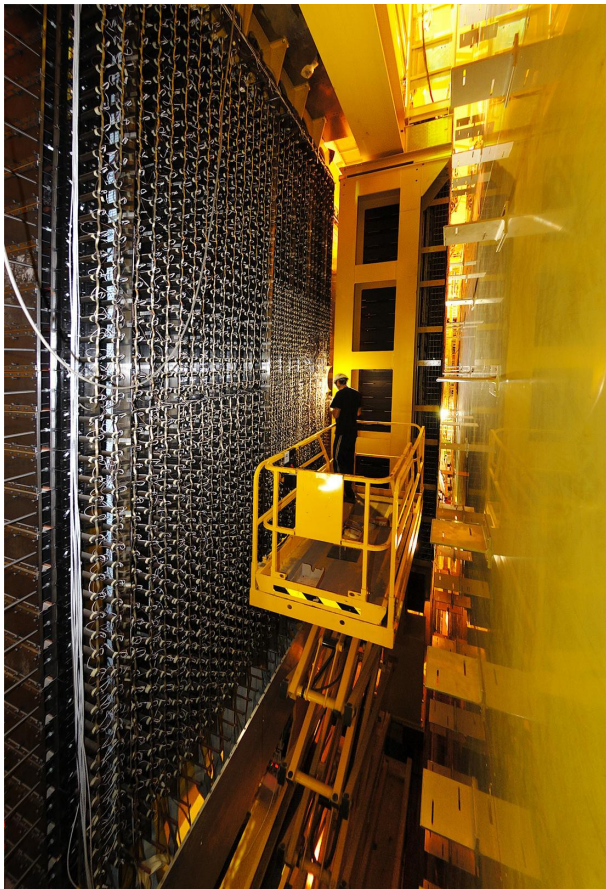
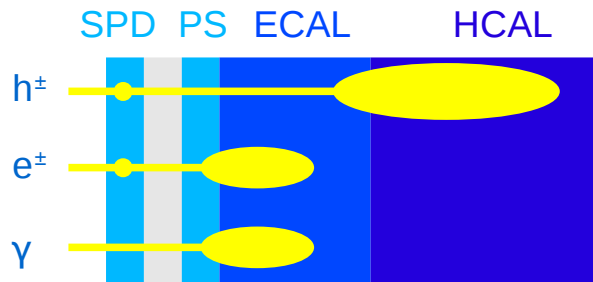

The ECAL detector

Scintillator Pad Detector / PreShower :

- robust e/γ and e/hadron separation
- single layer scintillator tiles separated by Pb sheet ($2.5 X_0$)
- $\epsilon(e^\pm) = 90\%$ for 5% e-hadron MisID

Electromagnetic CALorimeter :

- e and γ energy measurement
- trigger on electromagnetic decay channels
- Pb plates / scintillator tiles ($25 X_0$)
- $\sigma(E)/E = 10\%/\sqrt{E(\text{GeV})} + 1\%$ (nominal)

Hadronic CALorimeter :

- energy measurement for hadron
- trigger on hadronic decay channels
- Fe plates / scintillator tiles
- $\sigma(E)/E = 69\%/\sqrt{E(\text{GeV})} + 9\%$ (nominal), moderate but enough for triggering

Particle identification : electron, photon and π^0

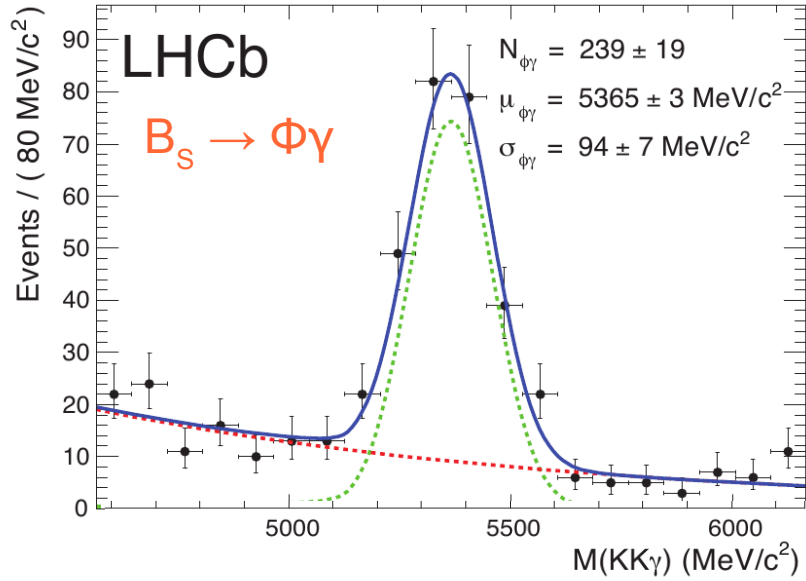
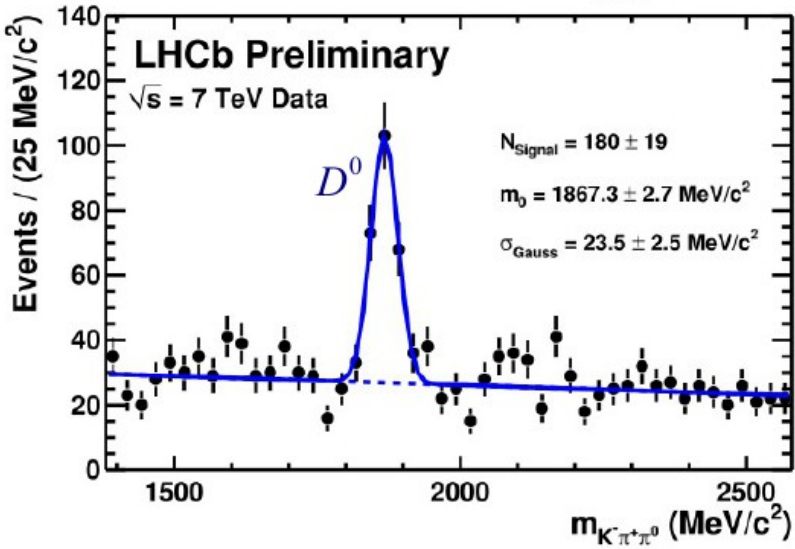
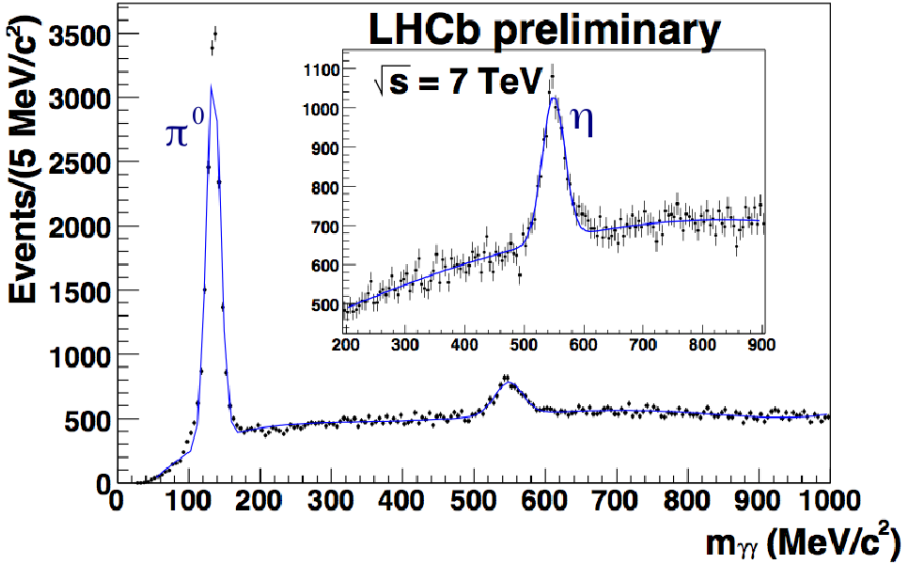
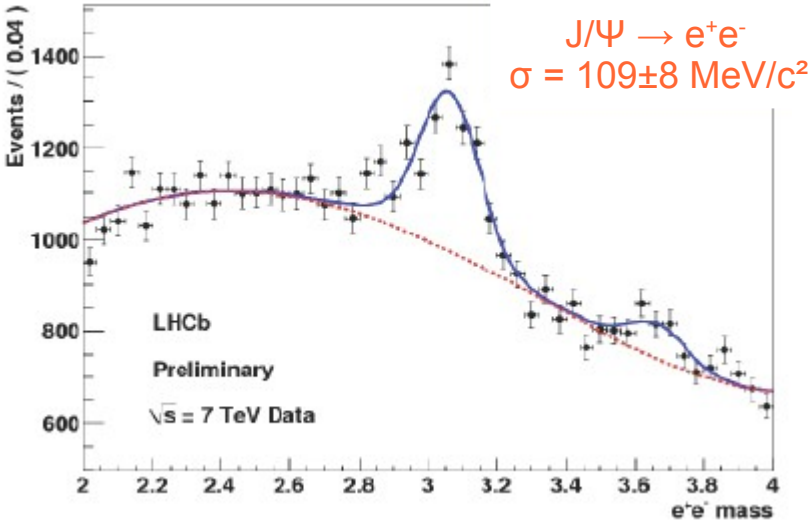

[arXiv:1202.6267]

Particle identification : the muon system

5 stations interleaved with iron absorbers

- muon identification
- trigger on muonic decay channels
- Muon ID $\epsilon(\mu) = 97\%$ for 1-3% π - μ MisID

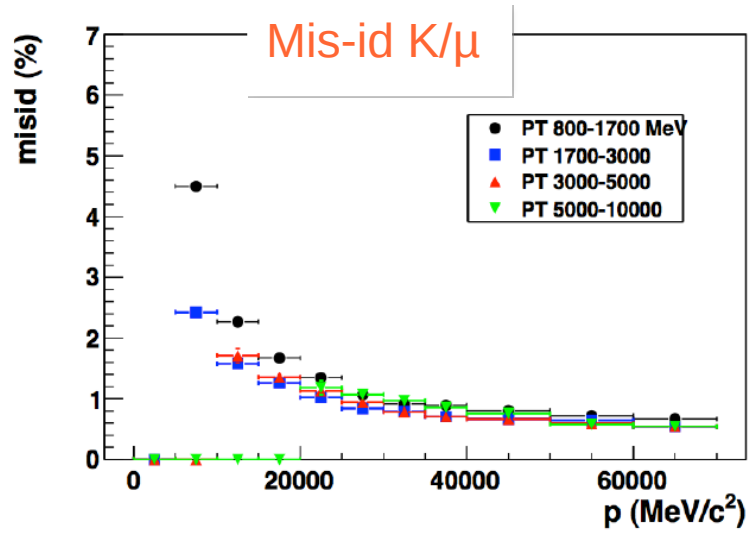
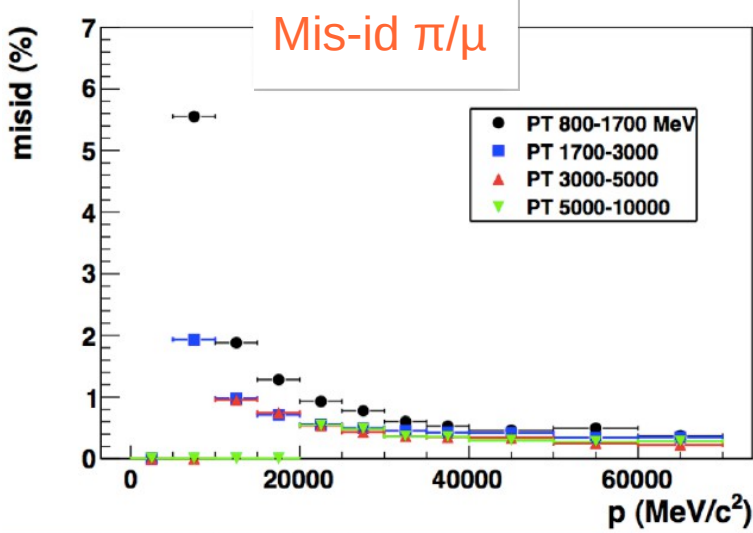
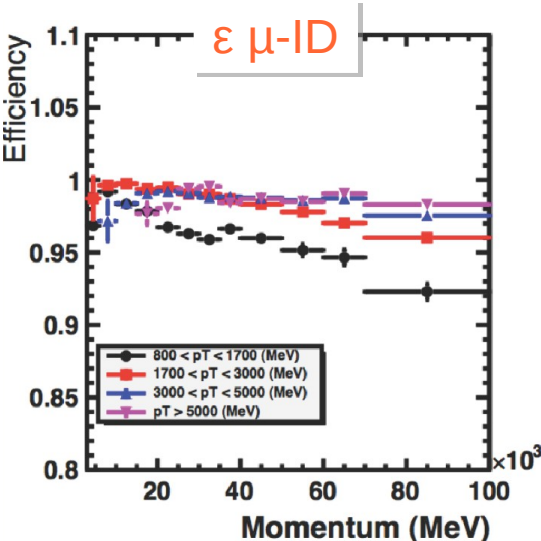
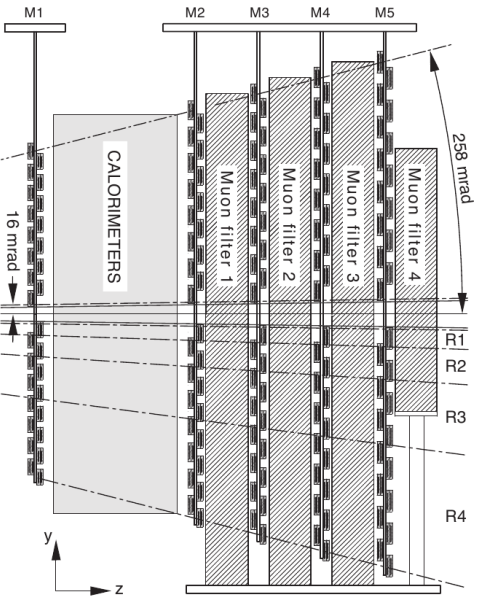
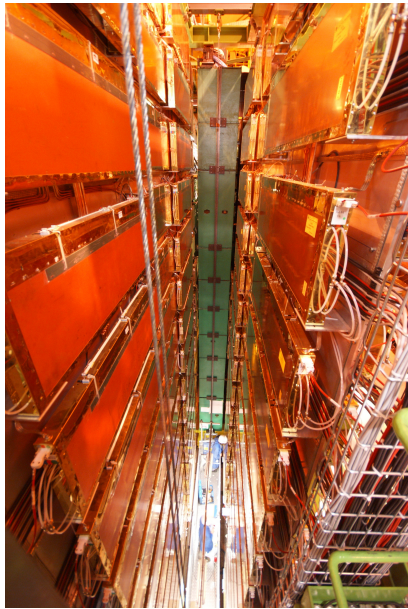

Trigger & stripping

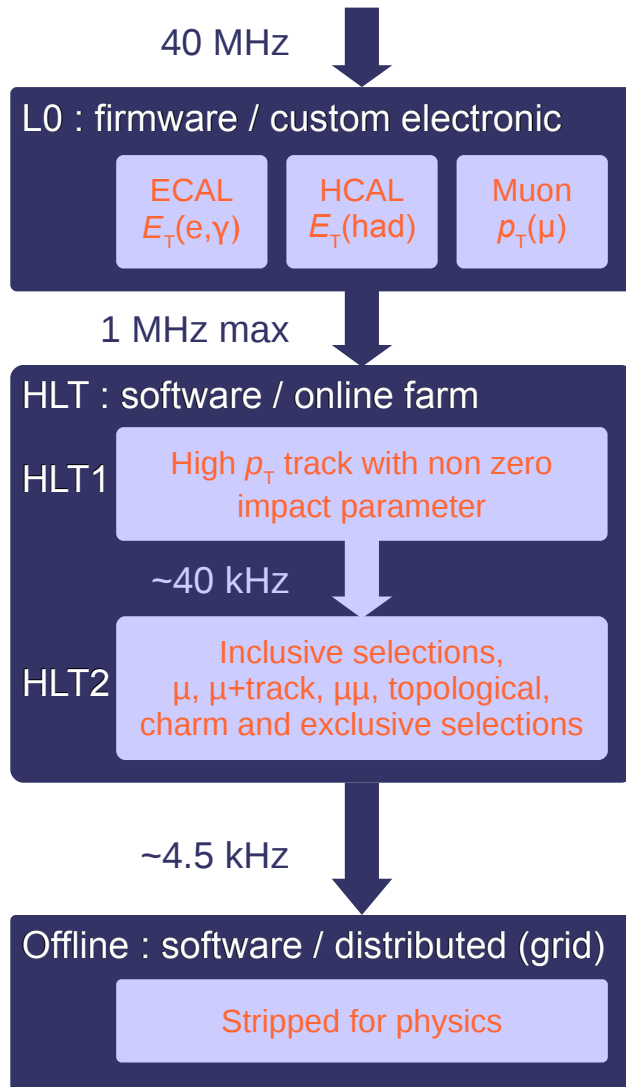

L0 : custom electronic @40Mhz, 4 μ s latency

- search for high- p_T μ , e, γ , hadron candidates
→ $p_T(\mu) > 1.4$; $E_T(e/\gamma) > 2.7$; $E_T(\text{hadron}) > 3.6$ [GeV]

HLT : software trigger

- ~ 30000 tasks in parallel on ~1500 nodes
- HLT1 : add Impact Parameters cuts
- HLT2 : global event reconstruction tuned for HLT

Efficiencies :

- di-muons channels : ~ 90 %
- multi-body hadronic final states : 30 %

cf. H. Dijkstra's talk

Offline : ~ 10^{10} events, 700 TB recorded/year

- centralized stripping selections to reduces to samples with $0(10^7)$ events for individual analyses

→ ~800 selections

LHCb Operation

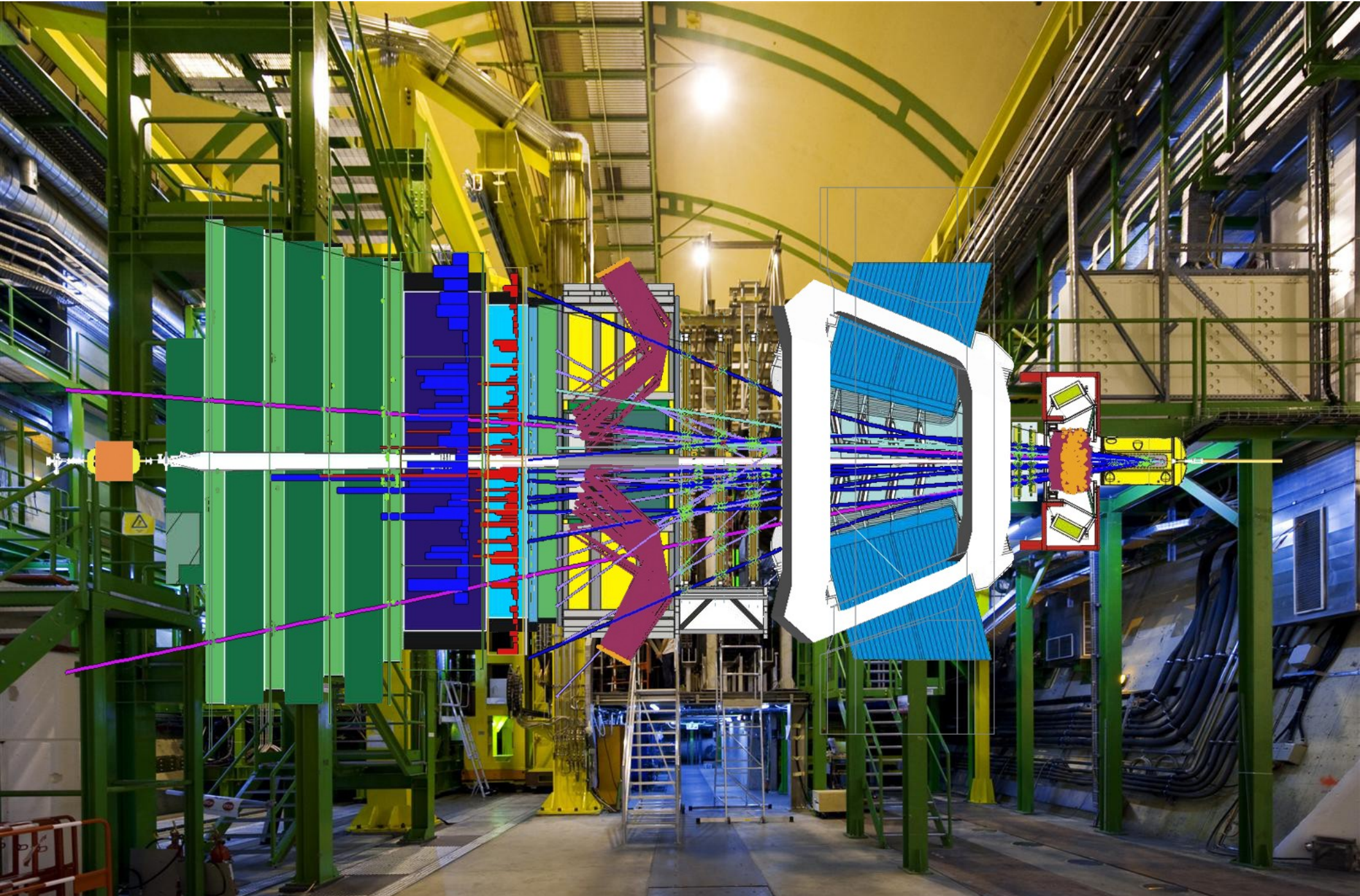

Data Taking

LHCb Integrated Luminosity in 2011 and 2012

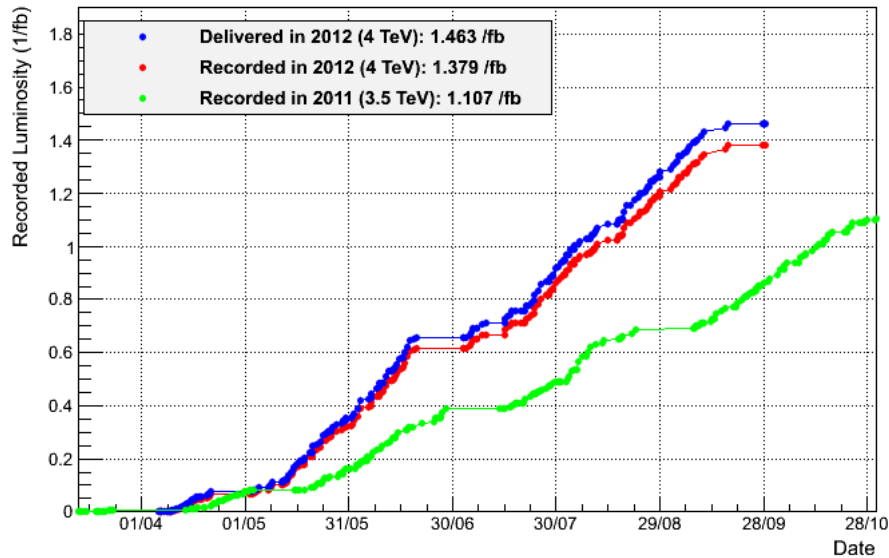

Recorded Luminosity :

- 2010 : 37 pb⁻¹ @ 7 TeV
 - 2011 : 1 fb⁻¹ @ 7 TeV
 - 2012 : aim at 2.2 fb⁻¹ @ 8 TeV
(as of end of September : 1.4 fb⁻¹)
- expect $\sigma(b\bar{b})$ increased by ~15% w.r.t 7TeV

Integrated LHCb Efficiency breakdown in 2012

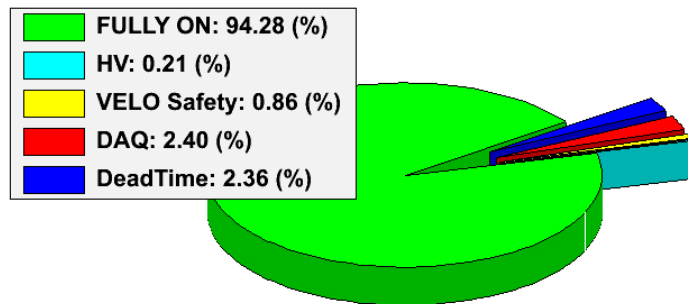

Efficiencies :

- > 90 % data taking efficiency
- ~99 % working detector channels
- > 99% of recorded data good for analysis

Luminosity

LHCb designed luminosity :

- $\mathcal{L}^{inst} = 2 \times 10^{32} \text{ cm}^{-2}\text{s}^{-1}$ with $\mu=0.4$ (# of visible pp int./crossing)
- Precision physics depending on vertex structure
 - easier in a low-pileup environment

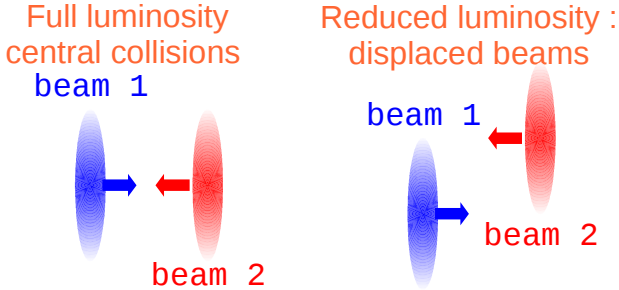

Luminosity levelling at LHCb

- run with constant luminosity
 - beam overlap adjusted regularly
- automatic procedure between LHC&LHCb

2011 & 2012 instantaneous luminosities :

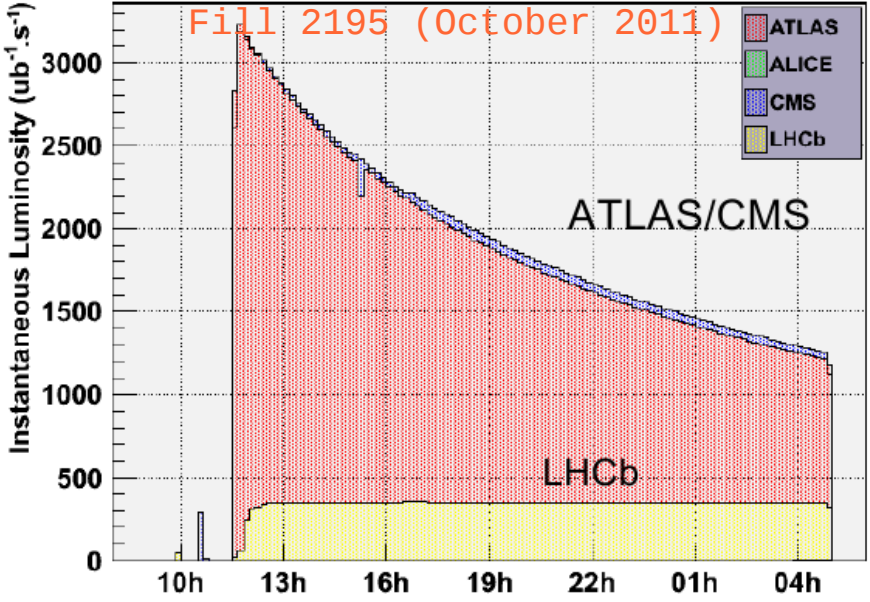
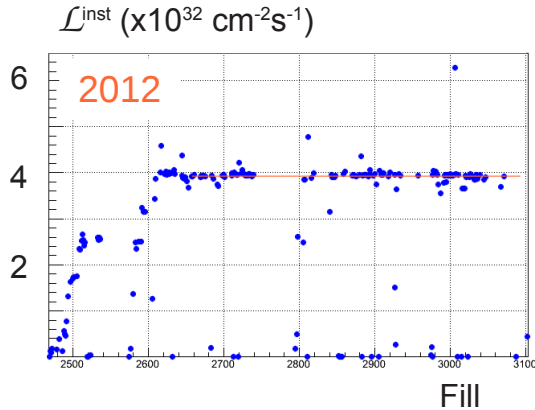
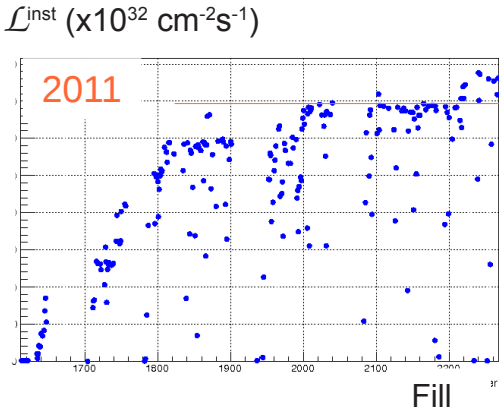

2011 : $\mathcal{L}^{inst} = \sim 3.5 \times 10^{32} \text{ cm}^{-2}\text{s}^{-1}$, $\mu = \sim 1.5$

2012 : $\mathcal{L}^{inst} = \sim 4.0 \times 10^{32} \text{ cm}^{-2}\text{s}^{-1}$, $\mu = \sim 1.7$

2012 novelties

Optimisation of data acquisition :

- L0 rate from 925 kHz to 975 kHz
- allow to run at higher luminosity

Deferred HLT triggering :a

- the HLT processing of a fraction (20%) of the L0 rate is deferred
- deferred event are written to disk and processed by the HLT in the inter-fill gap
- equivalent to 20% gain in CPU power

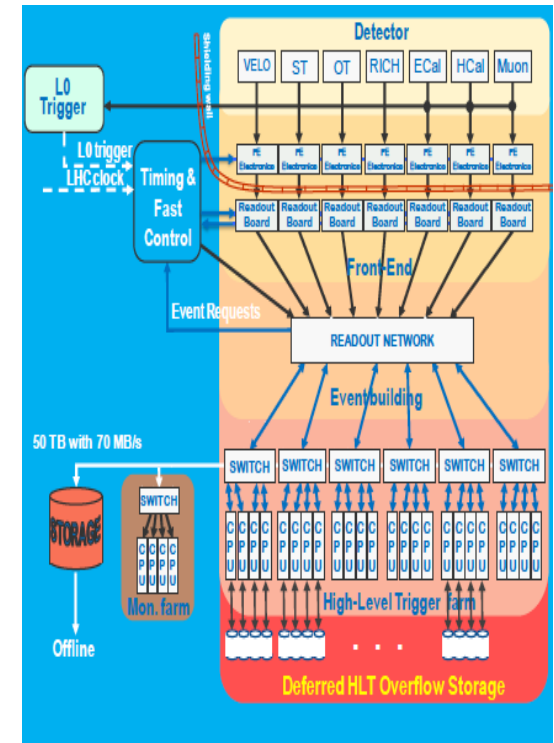

2011

2012

LHC optics :

- beams crossing angle change from horizontal plane in 2011 to vertical plane in 2012
- decoupled from LHCb magnet polarity change (H bending)
- minimize systematic effects

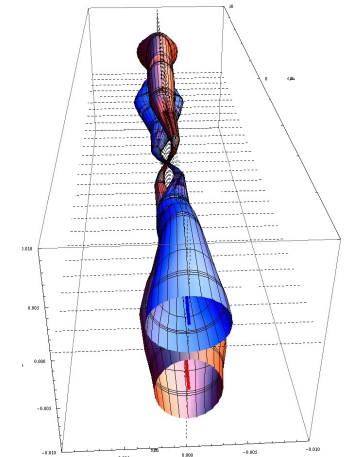
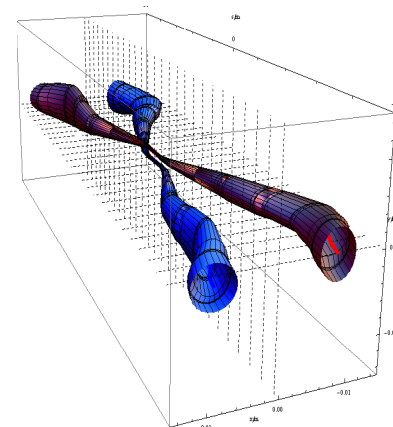

Conclusions

LHCb detector achievements :

- excellent vertex resolution
- great tracking performances
- robust particle identification
- flexible and efficient trigger

LHCb operation :

- smooth and efficient
- sustain luminosity higher than designed value

LHCb able to deliver high-quality physics results

- ~70 submitted papers
- world's best measurements of many important physics parameters
- upgrade activities launched

Conclusions

LHCb detector achievements :

- excellent vertex resolution
- great tracking performances
- robust particle identification
- flexible and efficient trigger

LHCb operation :

- smooth and efficient
- sustain luminosity higher than designed value

LHCb able to deliver high-quality physics results

- ~70 submitted papers
 - world's best measurements of many important physics parameters
 - upgrade activities launched → H. Dijkstra
- Overview → M. Patel
 - Rare decays → M.O. Bettler
 - CP violation → C. Fitzpatrick
 - b-hadron production → B.Popovici

Thank you for your attention

