

April 15-19, 2012
Newport News Marriott City Center
hosted by: Jefferson Lab

BIW 12

The 2012 Beam Instrumentation Workshop (BIW12) will be the 15th biennial workshop dedicated to exploring the physics and engineering challenges of beam diagnostic and measurement techniques for charged particle accelerators. This meeting program will include tutorials on selected topics, invited and contributed talks, as well as poster sessions. This will be the last BIW, after which IBIC (International Beam Instrumentation Conference) will follow the PAC rotation; Asia, Europe, and the US.

Program Committee:	Tom Shea, (SNS)	Jefferson Lab Local Organizing Committee:
Kevin Jordan, (Chate, JLab)	Pavel Fstulhancko	
Daniela Filippetto, (LBNL)	Om Singh, (BNL)	Cynthia Lockwood
Doug Gilpatrick, (LANL)	Steve Smith, (SLAC)	John Mazson
Ken Jacobs, (SRG)	Hitoshi Tanaka, (SPRING-8)	Todd Satogata
Rhodri Jones, (CERN)	Jonah Weber, (LBNL)	
Bob Lill, (ANL)	Manfred Wendt, (FNAL)	
Toshiyuki Mitsuhashi, (KEK)	Michelle Wilinski, (BNL)	
Guenther Rehm, (DIAMOND)	Kay Wittenburg, (DESY)	
Jim Sebek, (SLAC)	Jim Zagel, (FNAL)	

Student Fellowships Available - apply by Oct. 1, 2011
<http://conferences.jlab.org/biw12>

15th Beam Instrumentation Workshop
April 15-19, 2012

FARADAY CUP 2012

Beam Diagnostic Instrument:

A device to measure the properties of charged elementary particle, atomic or simple molecular beams during or after acceleration, or the properties of neutral particle beams produced in an intermediate stage of charged particle acceleration. The device may operate by detecting secondary beams of charged, neutral, massive or mass less particles. But its purpose should be to diagnose the primary charged particle beam. The mass of primary beam particles shall be no greater than the order of 1000 atomic mass units.

Delivered Performance:

The performance of the device should have been evaluated using a charged particle beam, rather than in a "bench top" demonstration.

Publication:

A description of the device, its operating principle, and its performance should have been published in a journal or in the proceedings of a conference or workshop that is in the public domain. Laboratory design notes, internal technical notes, etc., do not qualify but may be submitted to support other publications. Full and open disclosure is necessary to the extent that a potential user could design a similar device. More than one article may be submitted (together) to satisfy this requirement; for example, an article describing the principle plus another article describing the performance.



Eligibility

Nominations are open to candidates of any nationality for work done at any geographical location. There are no restrictions for candidates, with the only exception that they cannot be members in charge of the BIW Program Committee. In the event of deciding between works of similar quality, preference will be given to candidates in an early stage of their beam instrumentation career. The award may be shared between persons contributing to the same accomplishment. Once accepted by the Award Committee a nomination shall remain eligible for two successive competitions unless withdrawn by a candidate.

Disclosure:

The Award Committee may release the names of entrants and a list of publications related to an entry if requested by a third party. Unpublished supporting material will not be disclosed nor will the names of persons supporting a nomination. Discussion regarding individual entries, scoring, etc. is regarded as confidential and will not be disclosed.

Nominations:

The nomination package shall include the name of the candidate, relevant publications, a statement outlining his/her personal contribution and that of others, letters from two professional accelerator physicist, engineers or laboratory administrative personnel who are familiar with the device and its development.

Winner selection criteria and rules, submission rules and deadline for submission are published on www.faraday-cup.com

Innovative Beam Instrumentation Award

Sponsored by Bergoz Instrumentation

3D & the BBQ - Observing beam oscillations with sub-micrometre amplitudes

Marek Gasior

Beam Instrumentation Group, CERN

Outline:

- Basics of tune measurement
- Challenges of the LHC tune measurement
- History of the development
- Principles of the direct diode detection (3D)
- Base-Band Tune (BBQ) systems
- Measurement examples
- Other development triggered by the diode detection project

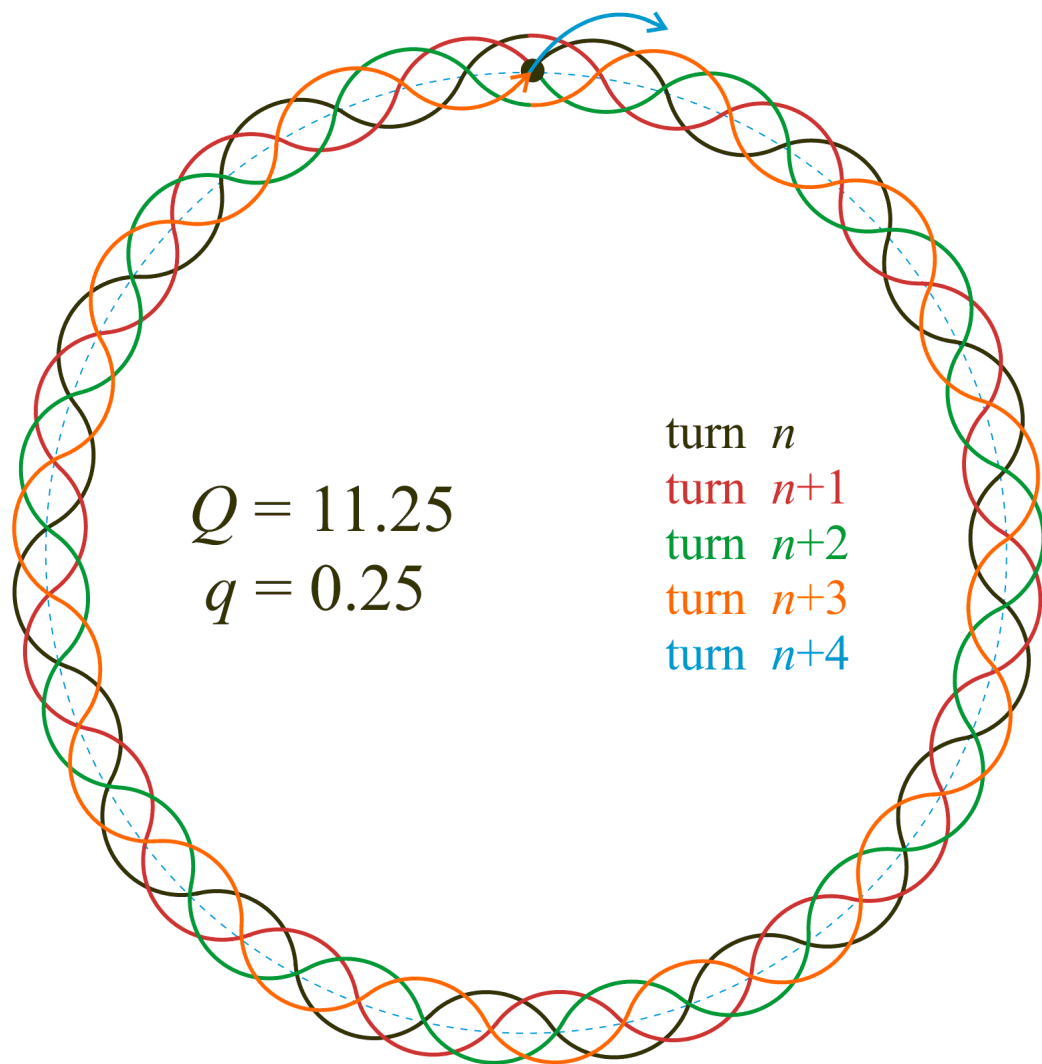

Q – betatron tune,
betatron wave number

q – fractional tune,
operation point

- All particles undergo betatron motion, forced by the machine quadrupoles.
- Betatron oscillations must not superimpose in-phase on themselves after few revolution periods.
- In-phase superposition of betatron oscillations leads to a resonant amplitude build-up.
- Eventually betatron oscillations may not fit into available aperture and beam can be lost.
- Real life is more complex than that:
 - two motion planes, horizontal and vertical;
 - coupling between the planes;
 - oscillation amplitude in each plane changes from one location to another according to a function (so called β -function);
 - betatron motion with larger amplitudes is nonlinear.

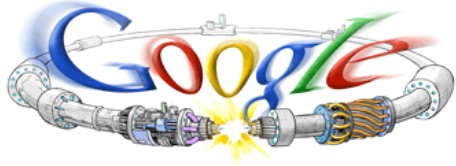

10/09/2008
From the LHC logbook:
"The World watches LHC"

A recipe to start a (circular) accelerator:

- First you use the BPMs to steer the beam to make the first turn ...
- You measure the tunes to set them in good values to make the beam circulating.
- Once beam circulates you can play with machine parameters to increase the beam lifetime, including the tunes.

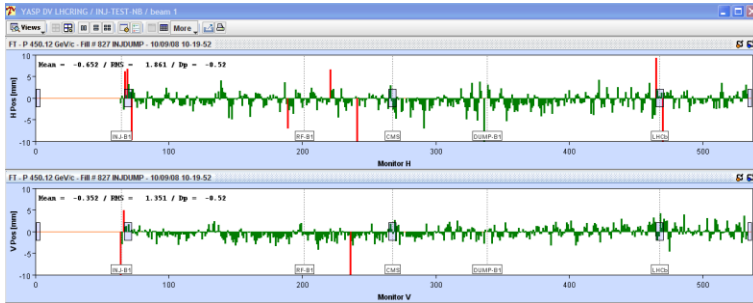

10:20 – almost one turn.

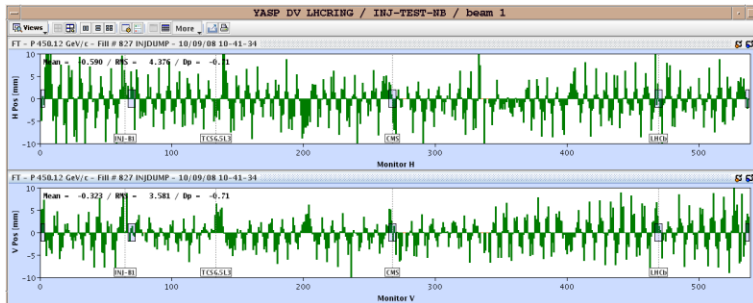

10:41 – first turn.

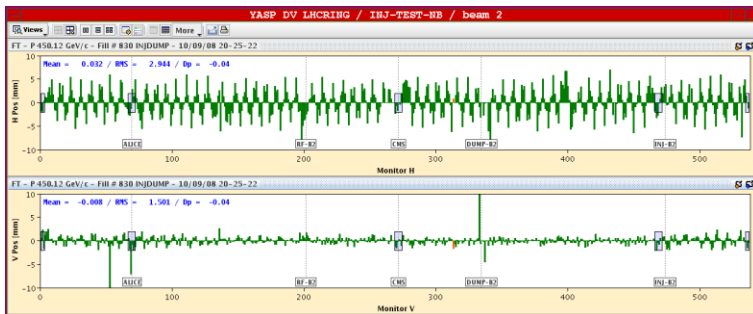

20:25 – a few turns, large oscillations, maybe a (1/3, 1/2) resonance ?

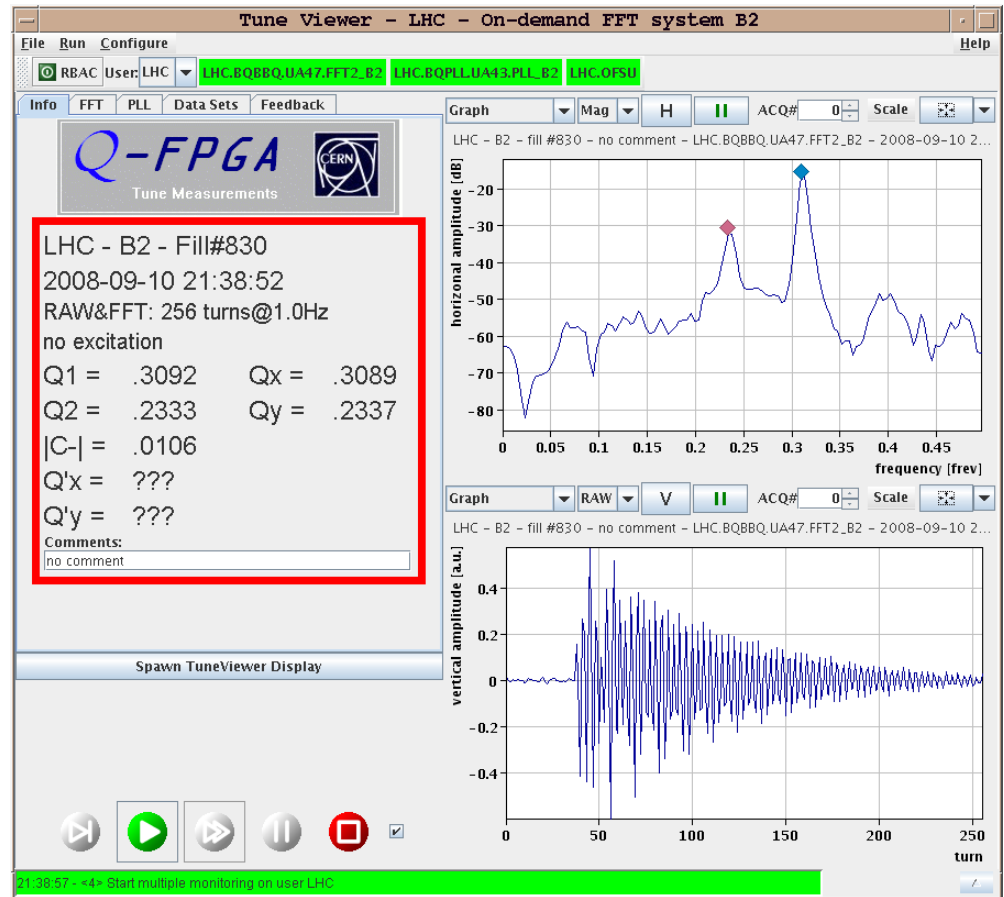

21:37 – Ralph measures the tunes to be indeed on a resonance and corrects them. Then beam circulates.

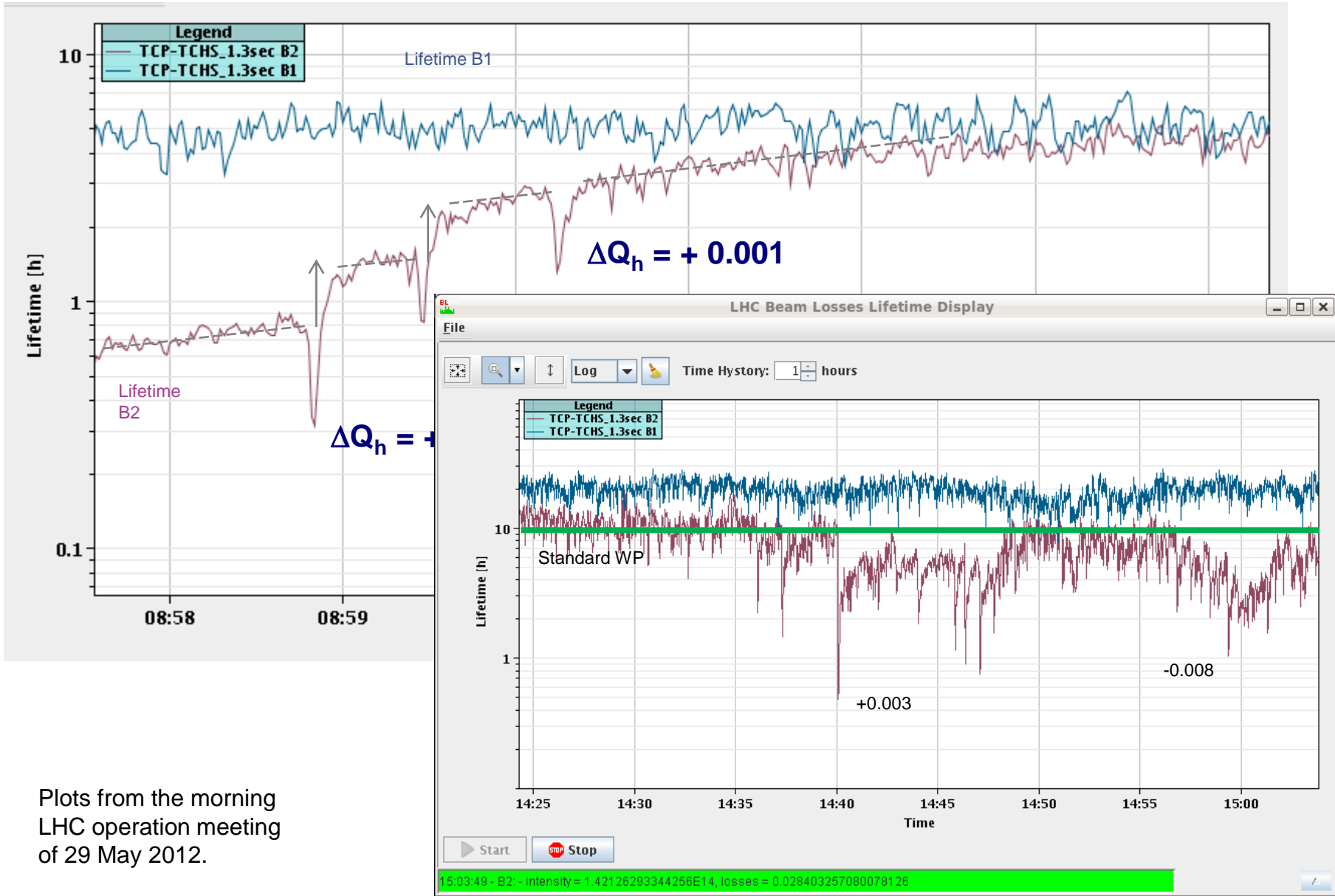

Plots from the morning LHC operation meeting of 29 May 2012.

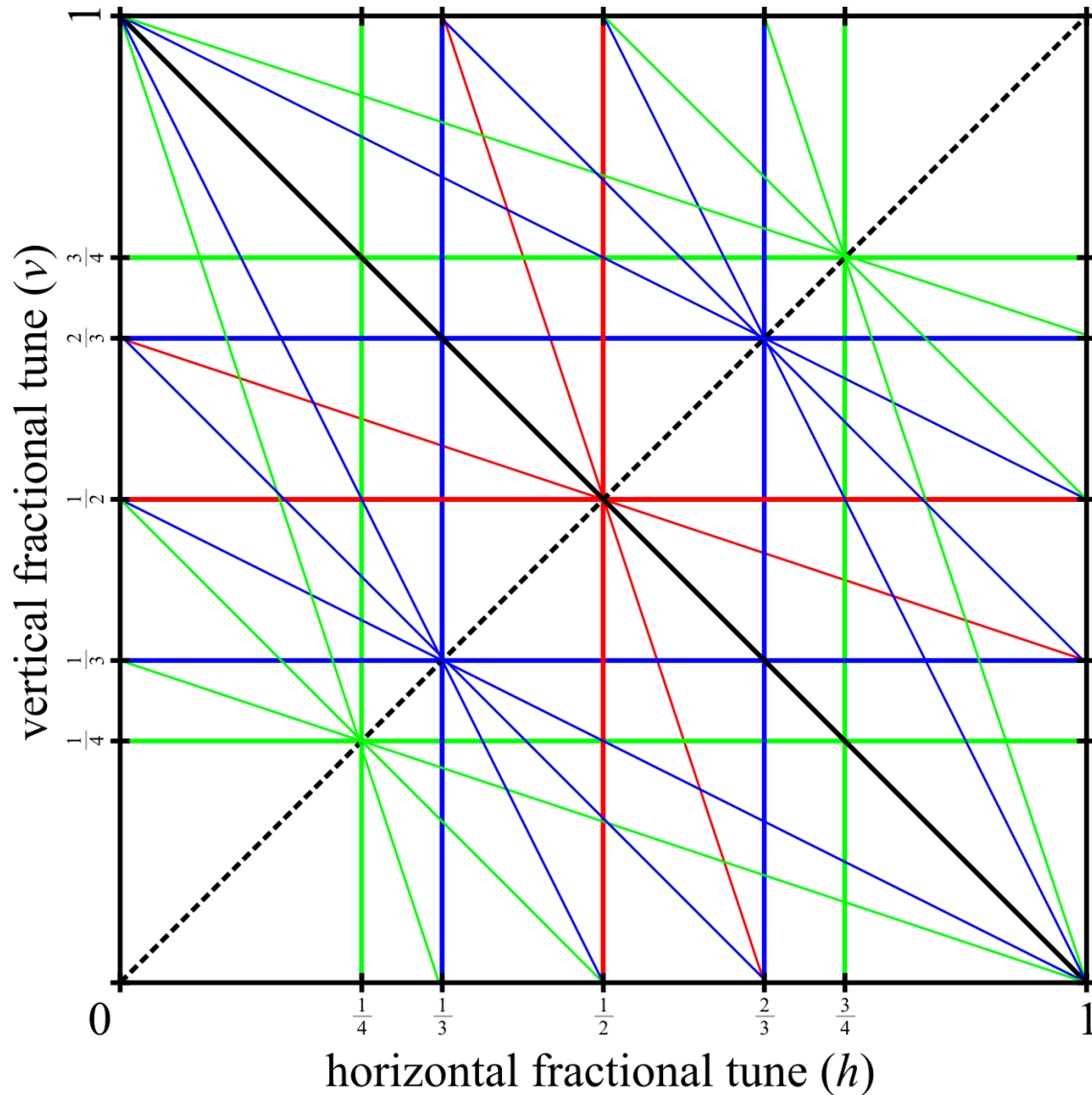

Resonance condition:

$$mh + nv = p$$

h, v - horizontal and vertical tunes
 m, n, p - small integers
 $|m| + |n|$ is the resonance order

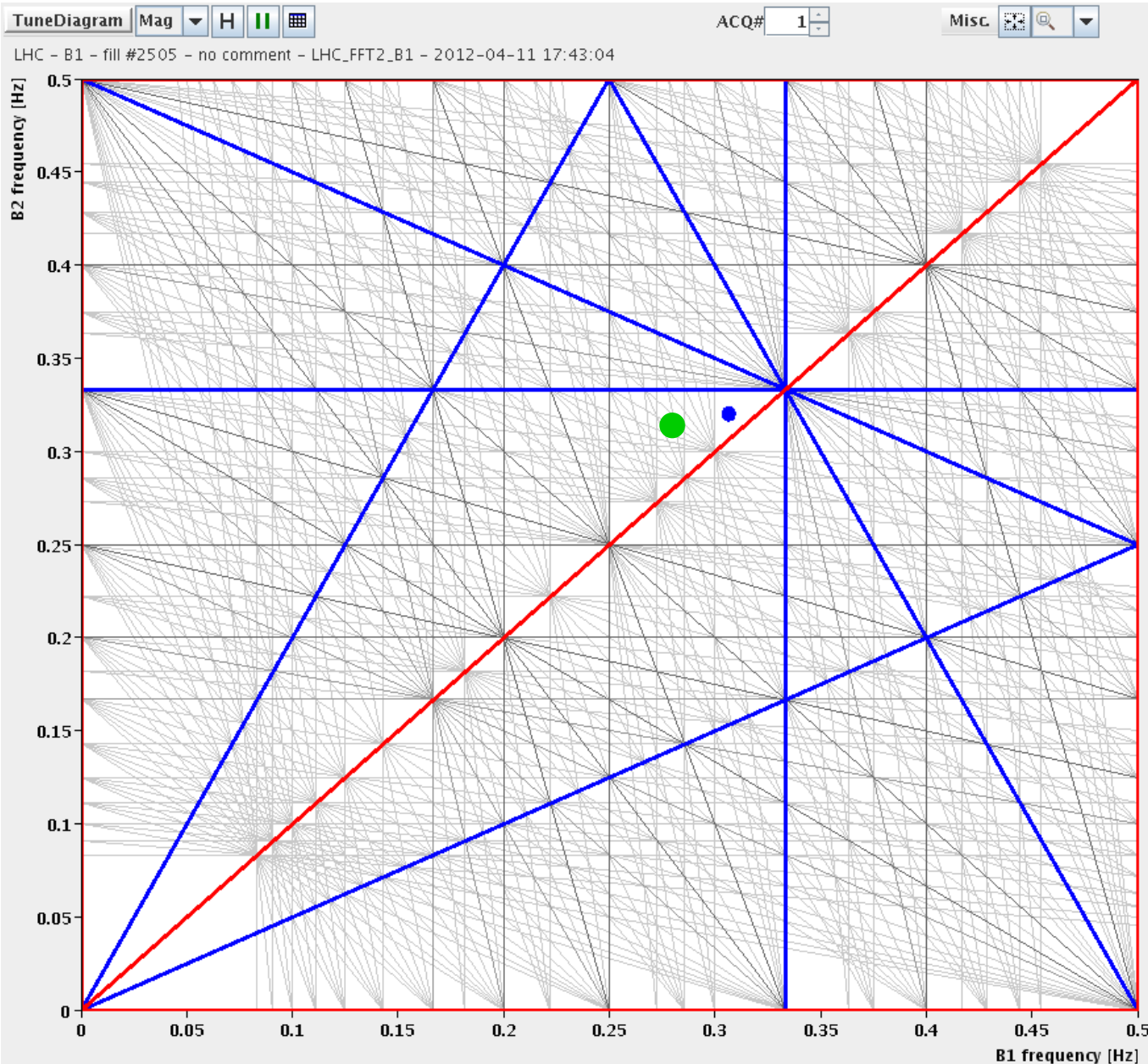

- LHC physics tunes:
H: 0.31, V: 0.32
- The blue dot comes from a real measurement during collisions at 4 TeV.
- LHC injection tunes:
H: 0.28, V: 0.31
- LHC integer tunes:
H: 59, V: 64
- LHC tunes must be kept on the design values within ≈ 0.001 .
- LHC has a tune feed-back system, i.e. during the ramp the LHC tunes are measured continuously and the readings are used to calculate the necessary corrections applied to the quadrupoles to keep the tunes on the design values.

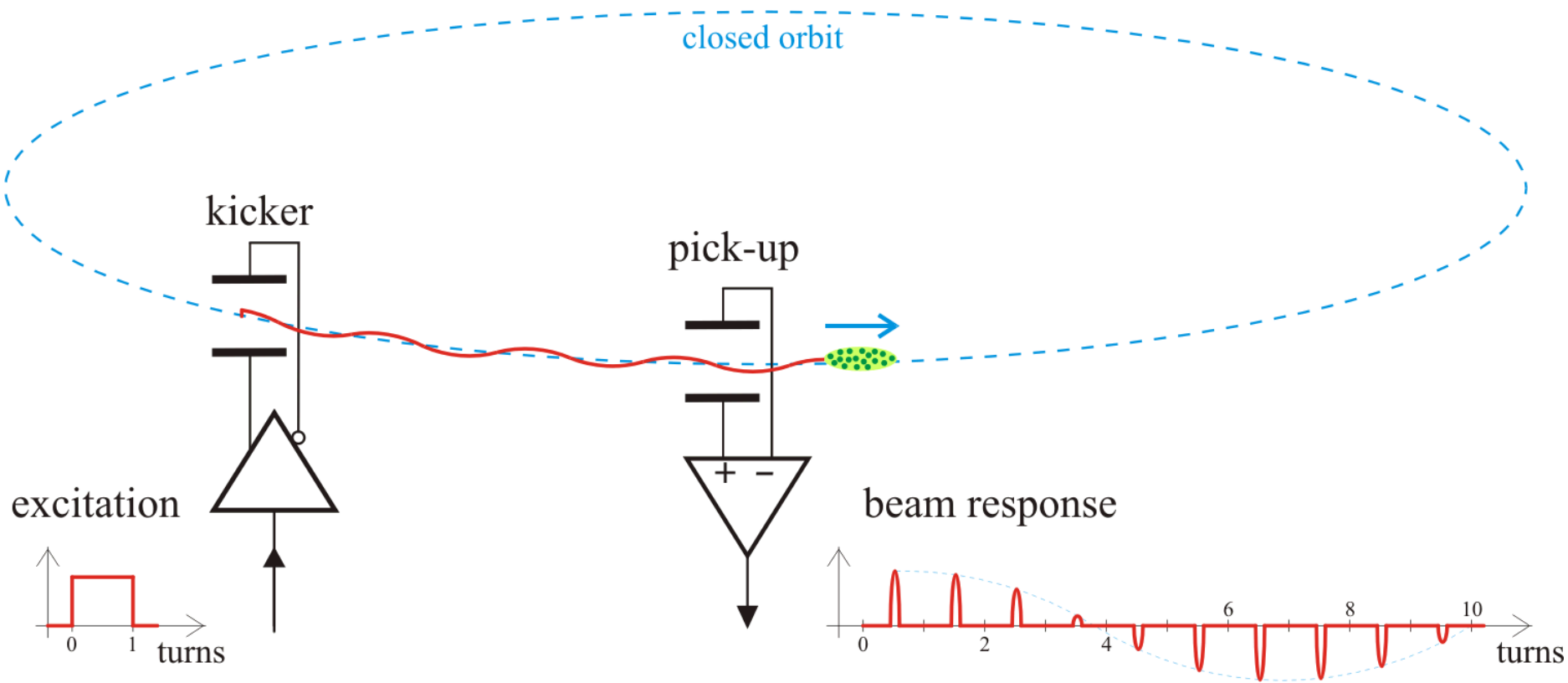

- Beam betatron oscillations are observed on a position pick-up
- Oscillations of individual particles are incoherent – an excitation needed for “synchronization”
- The machine tune is the frequency of betatron oscillations related to the revolution frequency.
- Betatron oscillations are usually observed in the frequency domain.
- With one pick-up only betatron phase advance from one turn to the next is known – only fractional tune can be measured.

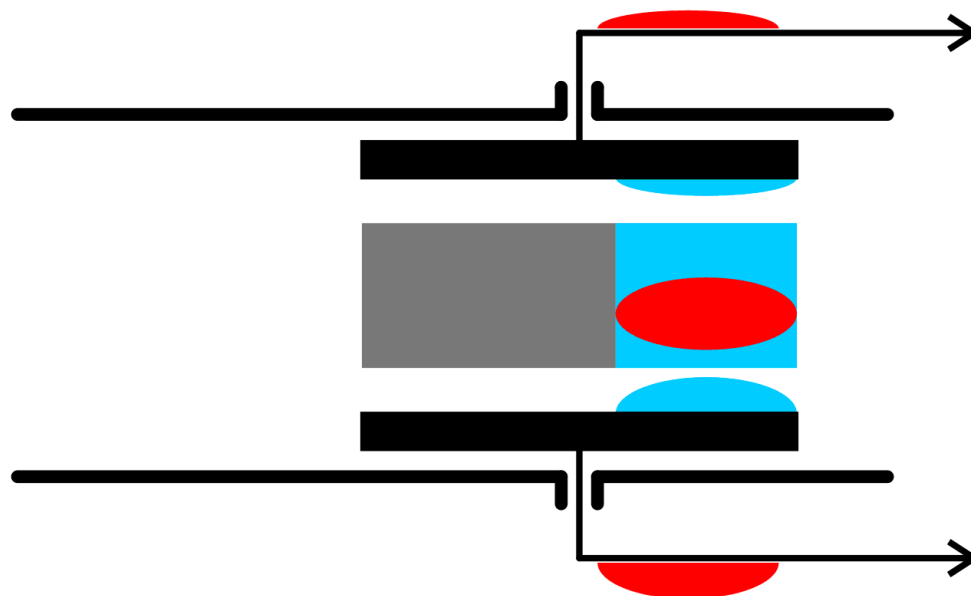
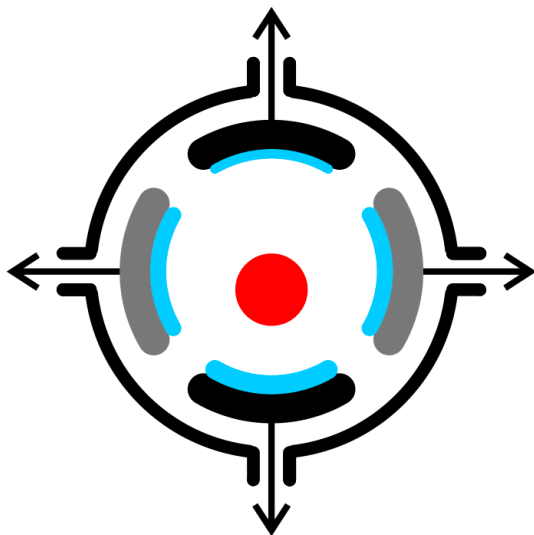

- Beam image current – the principle of operation of many beam instrumentation devices.
- Electrode signals are proportional to BOTH, beam position AND beam intensity.
- For measuring beam position the intensity component must be removed (often measured and used for a normalisation).
- There are many BPM types, with different electrode geometries, one or two ports per electrode.
- A stripline pick-up with two ports per electrode can distinguish signals of beams passing in the opposite directions (very useful for the LHC parts close to the experiments with both beams circulating in one pipe).
- The simplest beam kicker is a BPM working the other way around: it RECEIVES an excitation signal.

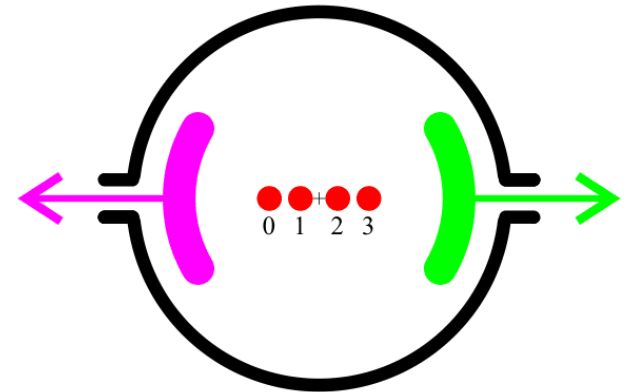
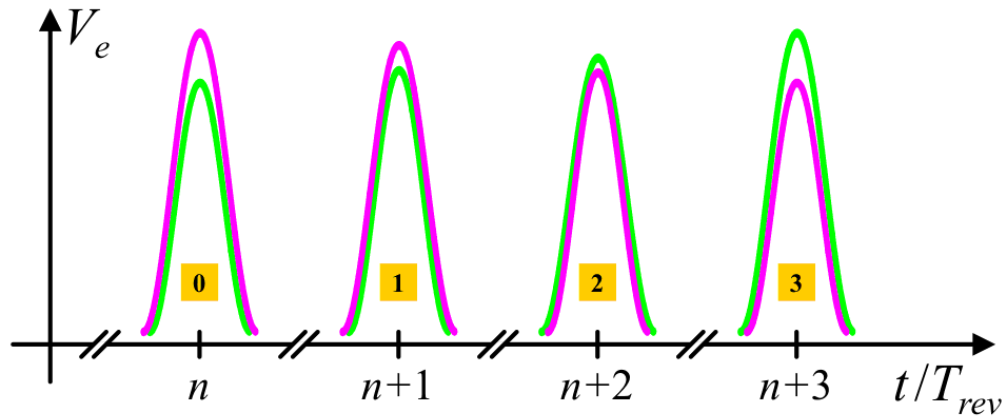

- Electrode signal has the temporal shape corresponding to the temporal structure of the passing beam.
- For single short bunches and large machines (as the LHC) the electrode signal has very small duty cycle.
- For the LHC nominal beams that means nanosecond pulses with the amplitudes in the order of 100 V.
- Such signals are very difficult to simulate in the lab.
- Continuous sampling of LHC single bunch signals would contain some 99.999 % of silence and sampling would have to be done at least at a few GHz rate.

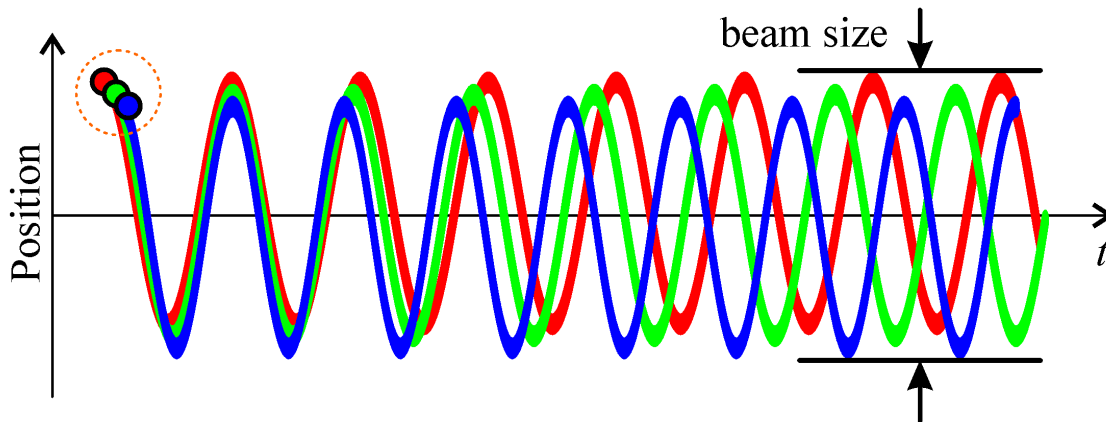
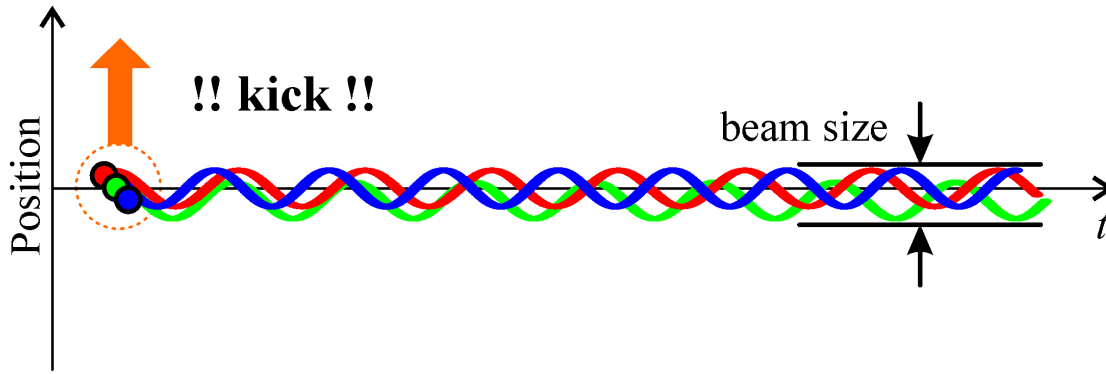

- Beam size is defined by the incoherent betatron motion of all particles.
- Smaller size = more luminosity.
- Particles have some momentum spread, leading to the spread in their deflection by the quadrupoles and finally to the spread in the frequency of the betatron oscillations.
- Protons do not forget: once hit they oscillate (practically) forever.
- LHC colliding beam size is in the order of 100 μm , so the excitation must be kept in the 1 μm range.
- LHC has a sophisticated collimation system, with some 100 collimators. Any oscillations significant w.r.t. the beam size are converted by the collimators into beam loss...

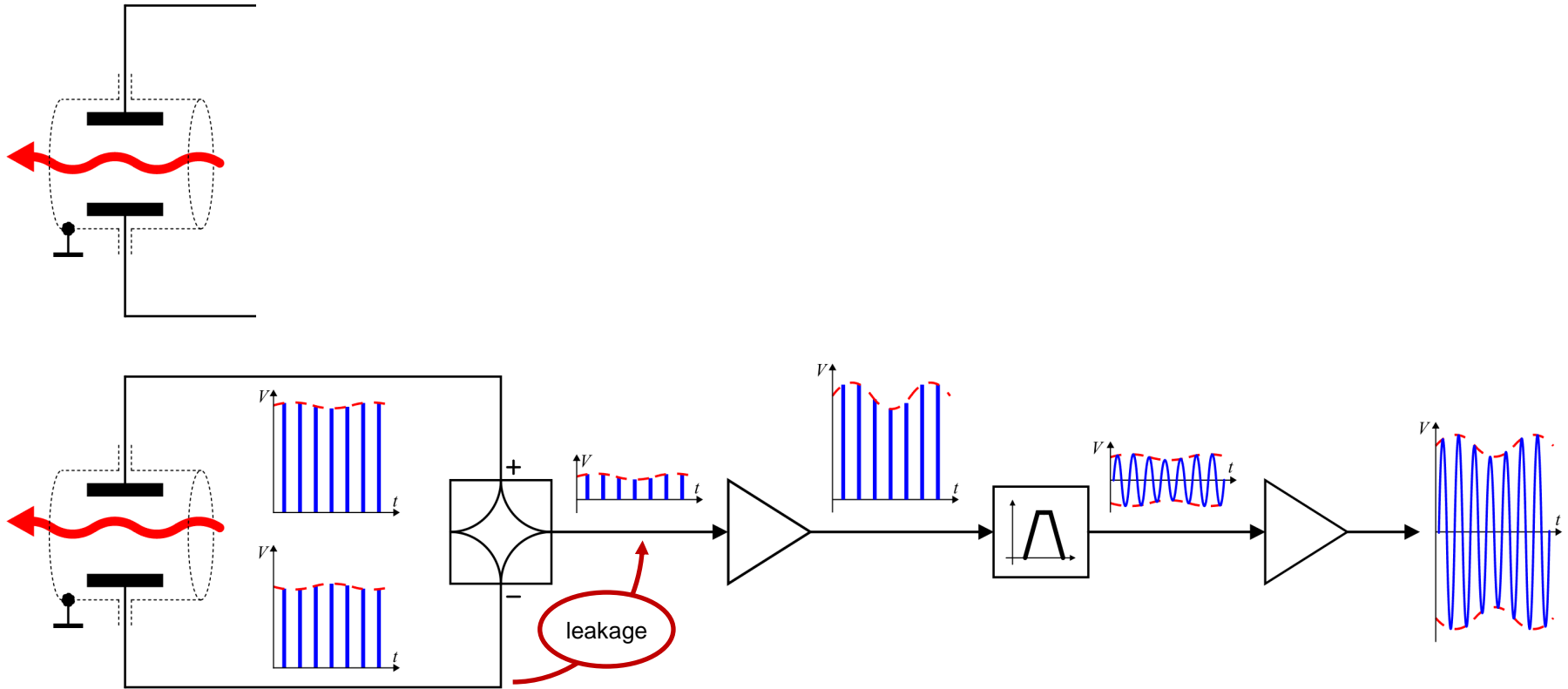

- Linear processing of position pick-up signals
- Dynamic range problems:
 - Signals related to betatron oscillations are small with respect to the beam offset signals.
 - Even if the beam is centred, the subtraction of the signals from the pick-up opposing electrodes is not perfect. The leakage is in the order of 1-10 % for ns beam pulses.
- Options to decrease beam offset signals:
 - centre the beam;
 - centre the pick-up;
 - equalise the signals by attenuating the larger one (electronic beam centring).

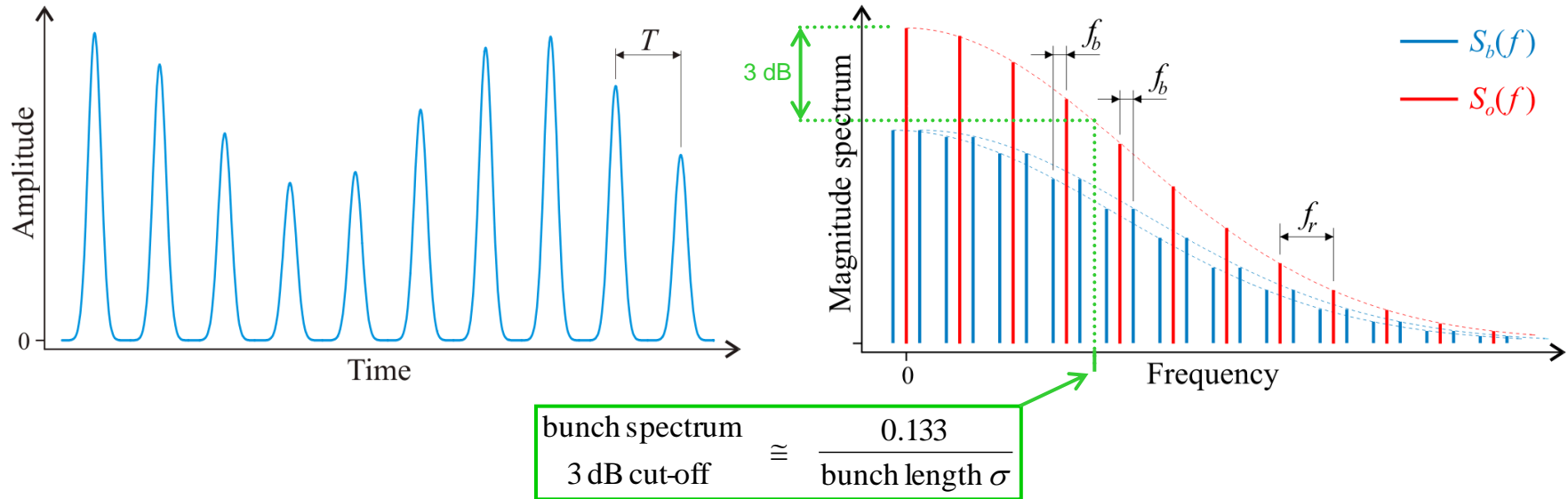

- Spectrum envelope is defined by the bunch shape. For a gaussian bunch the spectrum envelope is gaussian as well.
- The harmonic structure of the beam spectrum is defined by the time beam time structure.
- Short single bunches give large spectra, with many lines; most often this is the largest challenge for the tune meas. system.
- The LHC bunch length (4σ) is about 1 ns and the corresponding bunch power spectrum cut-off is about 500 MHz.
- With just one bunch in the machine the revolution spectral lines are spaced by 11 kHz, so by 500 MHz there are some 50 000 of them and some 100 000 betatron lines.
- In the classical tune measurement method only one betatron line is observed, so in the LHC case it is only some 10^{-5} (-100 dB) of the total spectral content.
- This results in very small signals, requiring low noise amplifiers and mixers, which have small dynamic ranges; they can be saturated even with relatively small beam offset signals.
- The “order of magnitude” estimates for pick-up signals, assuming electrode distance 100 mm and 100 V electrode signals:

1 mm beam offset signal:	$1 \text{ mm} / 100 \text{ mm} * 100 \text{ V} \approx 1 \text{ V}$
1 μm beam oscillation signal:	$1 \mu\text{m} / 100 \text{ mm} * 100 \text{ V} \approx 1 \text{ mV}$
1 μm beam oscillation signal observed at a single frequency:	$1 \text{ mV} * 10^{-5} \approx 10 \text{ nV}$

13.7.1 General tune Measurement System

This system will allow the measurement of tune via standard excitation sources (single kick, chirp, slow swept frequency, and noise). It should operate with all filling patterns and bunch intensities and be commissioned early after the LHC start-up. **Even with oscillation amplitudes down to 50 μm , a certain amount of emittance increase will result**, limiting the frequency at which measurements can be made. **It will therefore probably be unsuitable for generating measurements for an online tune feedback system. Dedicated stripline couplers will be mounted on 2-3 m long motorised supports that can be displaced horizontally or vertically with a resolution of 1 or 2 microns.** There will be two such supports near Q6 and Q5 left of IR4 and another two at Q5 and Q6 right of IR4. They will measure in one plane only to profit from the high β_h or β_v near each quadrupole (typically 400 m). Also mounted on each support will be the **resonant pick-up** (see Sec. 13.7.3) **and a standard warm button BPM dedicated to providing positions for a slow feedback loop keeping the BPM centred about the beam.** This will allow the electrical aperture of the tune coupler to be reduced to measure small position deviations about the closed orbit. Also, taking into account the higher signal level from the coupler design, the dedicated tune pick-ups will have a much higher sensitivity than the normal closed orbit BPMs for transverse oscillation measurements. **If necessary, electronic common mode rejection could also be included in the processing chain.** Measurements of individual bunch positions have been requested for this system. When the oscillation amplitude is sufficiently large, the orbit BPMs can also be used for tune measurement. It will be possible to measure the betatron function and phase advance all around the ring with them.

(...)

13.7.3 High Sensitivity Tune Measurement System

The beam is excited by applying a signal of low amplitude and high frequency, f_{ex} , to a stripline kicker. f_{ex} is close to half the bunch spacing frequency, f_b , (for the nominal 25 ns bunch spacing $f_b = 40$ MHz). The equivalent oscillation amplitude should be a few micrometers or less at a β -function of about 200 m. A notch filter in the transverse feedback loop suppresses the loop gain at this frequency, where instabilities are not expected to be a problem. If the excitation frequency divided by the revolution frequency corresponds to an integer plus the fractional part of the tune then coherent betatron oscillations of each bunch build up turn by turn (resonant excitation). A batch structure with a bunch every 25 ns “carries” the frequency f_{ex} as sidebands of the bunch spacing harmonics (i.e. at $(N \times 40 \text{ MHz}) \pm f_{\text{ex}}$). A beam position pick-up is tuned to resonate at one of these frequencies. By linking the generation of the excitation signal and the processing of the pick-up signal in a phase-locked loop (PLL) feedback circuit, the excitation can be kept resonant and the tune can be determined continuously. Emittance growth is controlled by maintaining the excitation level as small as possible, compatible with the required measurement precision and rate. Since the first derivative of the phase as a function of frequency goes through a maximum at the central value of the tune, this method gives the highest precision for a given oscillation amplitude. The tune values produced could be used as input to a tune feedback loop. **It must be emphasized though that the present design of the system is optimised for luminosity runs with batched beams with 25 ns bunch spacing. The handling of other bunch spacings at multiples of 25 ns should be possible, but the magnitude of the pick-up signal diminishes with increasing bunch spacing. The development of a PLL tune measurement system for the LHC is being done in collaboration with Brookhaven National Laboratory, where a similar system has been installed in RHIC. It is clear that the system will not be operational during the early stages of commissioning the LHC. Indeed, the beams planned for initial commissioning (single bunch, 43 equally spaced bunches, etc.) are incompatible with this method.**

13.7.1 General tune Measurement System

This system will allow the measurement of tune via standard excitation sources (single kick, chirp, slow swept frequency, and noise). It should operate with all filling patterns and bunch intensities and be commissioned early after the LHC start-up. **Even with oscillation amplitudes down to 50 μm , a certain amount of emittance increase will result, limiting the frequency at which measurements can be made. It will therefore probably be unsuitable for generating measurements for an online tune feedback system. Dedicated stripline couplers will be mounted on 2-3 m long motorised supports that can be displaced horizontally or vertically with a resolution of 1 or 2 microns. There will be two such supports near Q6 and Q5 left of IR4 and another two at Q5 and Q6 right of IR4. They will measure in one plane only to profit from the high β_x or β_y near each quadrupole (typically 400 m). Also mounted on each support will be the resonant pick-up (see Sec. 13.7.3) and a standard warm button BPM dedicated to providing positions for a slow feedback loop keeping the BPM centred about the beam. This will allow the electrical aperture of the tune coupler to be reduced to measure small position deviations about the closed orbit. Also, taking into account the higher signal level from the coupler design, the dedicated tune pick-ups will have a much higher sensitivity than the normal closed orbit BPMs for transverse oscillation measurements. If necessary, electronic common mode rejection could also be included in the processing chain. Measurements of individual bunch positions have been requested for this system. When the oscillation amplitude is sufficiently large, the orbit BPMs can also be used for tune measurement. It will be possible to measure the betatron function and phase advance all around the ring with them.**

(...)

13.7.3 High Sensitivity Tune Measurement System

The beam is excited by applying a signal of low amplitude and high frequency, f_{ex} , to a stripline kicker. f_{ex} is close to half the bunch spacing frequency, f_b , (for the nominal 25 ns bunch spacing $f_b = 40$ MHz). The equivalent oscillation amplitude should be a few micrometers or less at a β -function of about 200 m. A notch filter in the transverse feedback loop suppresses the loop gain at this frequency, where instabilities are not expected to be a problem. If the excitation frequency divided by the revolution frequency corresponds to an integer plus the fractional part of the tune then coherent betatron oscillations of each bunch build up turn by turn (resonant excitation). A bunch structure with a bunch every 25 ns “carries” the frequency f_{ex} , as sidebands of the bunch spacing harmonics (i.e. at $(N \times 40 \text{ MHz}) \pm f_{ex}$). A beam position pick-up is tuned to resonate at one of these frequencies. By linking the generation of the excitation signal and the processing of the pick-up signal in a phase-locked loop (PLL) feedback circuit, the excitation can be kept resonant and the tune can be determined continuously. Emittance growth is controlled by maintaining the excitation level as small as possible, compatible with the required measurement precision and rate. Since the first derivative of the phase as a function of frequency goes through a maximum at the central value of the tune, this method gives the highest precision for a given oscillation amplitude. The tune values produced could be used as input to a tune feedback loop. **It must be emphasized though that the present design of the system is optimised for luminosity runs with batched beams with 25 ns bunch spacing. The handling of other bunch spacings at multiples of 25 ns should be possible, but the magnitude of the pick-up signal diminishes with increasing bunch spacing. The development of a PLL tune measurement system for the LHC is being done in collaboration with Brookhaven National Laboratory, where a similar system has been installed in RHIC. It is clear that the system will not be operational during the early stages of commissioning the LHC. Indeed, the beams planned for initial commissioning (single bunch, 43 equally spaced bunches, etc.) are incompatible with this method.**

- Two tune measurement systems:
 - general: standard excitation sources (single kick, chirp, slow swept frequency, and noise);
 - high sensitivity: resonant PLL excitation, optimised for 25 ns bunch spacing and full machine.
- 3 sets of pick-ups:
 - 2-3 m long striplines for the general system;
 - resonant pick-ups for the high sensitivity PLL system;
 - button pick-ups dedicated to providing positions for a slow feedback loop keeping the tune pick-up centred about the beam.
- Beam oscillations made with the “standard excitation sources” with amplitudes in the order of 50 μm are considered small.
- Tune feed-back considered as probably not possible with the general tune measurement system (too large excitation necessary).
- Dealing with the revolution frequency background:
 - striplines on motorised supports which can be displaced in 1 or 2 micron steps;
 - electronic common mode rejection.
- “The development of a PLL tune measurement system for the LHC is being done in collaboration with Brookhaven National Laboratory, where a similar system has been installed in RHIC”.
- “It is clear that the (PLL) system will not be operational during the early stages of commissioning the LHC”.
 - **With this system complexity ONE ENGINEER would probably have to babysit the system all the time.**
 - **From today’s perspective, operating the LHC with the “Design Report tune measurement systems” would be extremely difficult, if not impossible.**

PLL Tune System 2 Single Channel Block

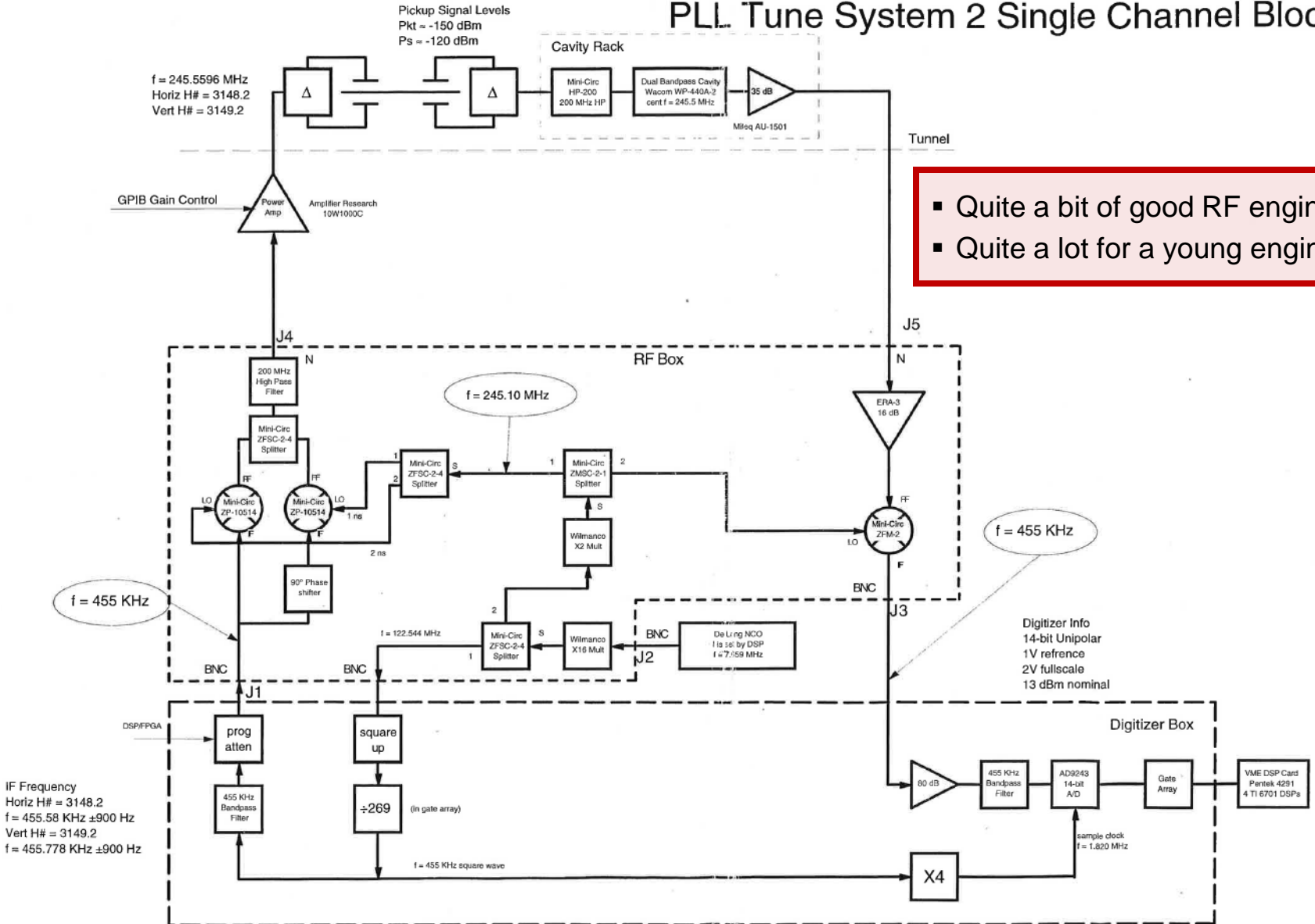

- Quite a bit of good RF engineering.
- Quite a lot for a young engineer.

- First key person: **Rhodri Jones**, later the section and group leader.
- Extreme February temperatures in NY made us spending a lot of time in coffee shops, which was very stimulating for our discussions, as it was proven later, very fruitful ones.

February - 02.2004

Mo	Tu	We	Th	Fr	Sa	Su
						1
2	3	4	5	6	7	8
9	10	11	12	13	14	15
16	17	18	19	20	21	22
23	24	25	26	27	28	29



Saturday (14/02): visiting NY



Sunday (15/02): visiting Long Island

- Second key person: **Peter Cameron**.
- Pete had by far more experience than us, but he took us serious and treated as real partners in the discussions.
- We came for learning, but Pete had also the patience to listen to our comments and ideas.

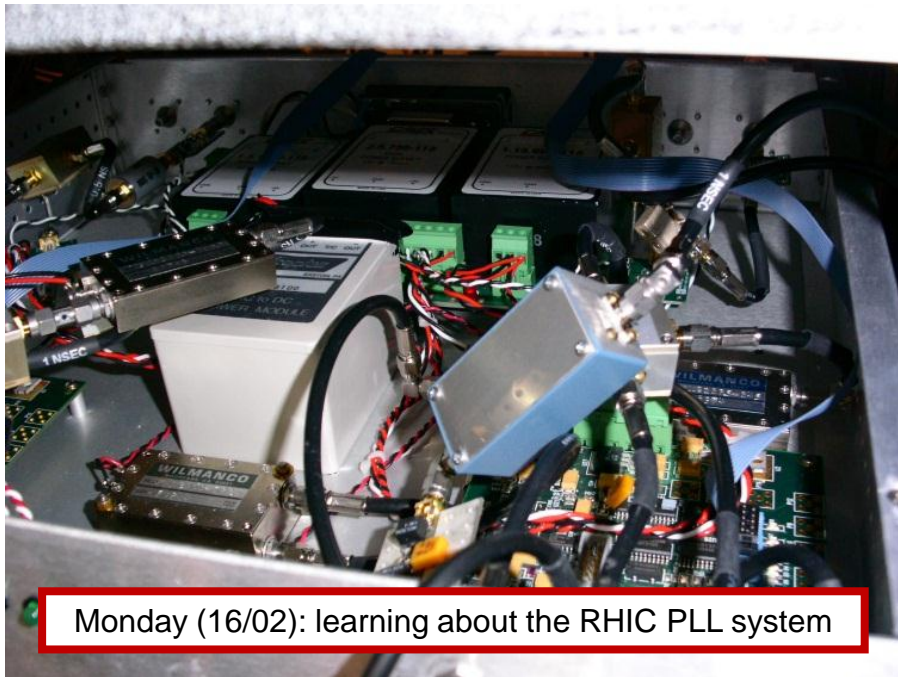

Monday (16/02): learning about the RHIC PLL system

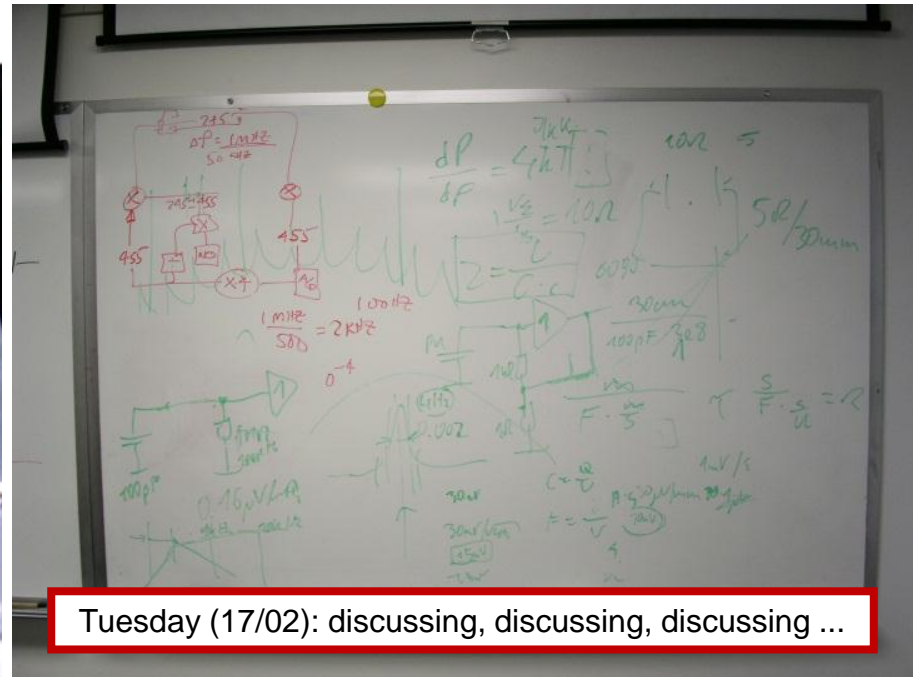

Tuesday (17/02): discussing, discussing, discussing ...

- RHIC system worked very well except when beam was crossing the transition, when the beam was changing the orbit rapidly. These orbit changes could not be followed by the movable pick-up system, otherwise keeping the beam in the pick-up centre to suppress the revolution frequency background. Thus, the system was suffering from the lack of the dynamic range.
- We need more dynamic range.
- Low frequency amplifiers may have some 20 Vpp of the input dynamic range, much more than RF amplifiers, typically not allowing more than 1 Vpp at the input. Therefore, we would prefer LF amplifiers !!!
- With LF amplifiers we might operate in the base-band, below the first revolution harmonic.
- At low frequencies there is beam energy, it is just that a typical pick-up does not have too much response there.
- The pick-up response may be extended to low frequencies by loading it to significantly higher impedance than 50 Ω , e.g. by using a high impedance input amplifier.
- Resonant pick-up is not efficient for single bunches, where the tune measurement is the most difficult. Since the LHC system HAS to work with single bunches, resonant pick-up does not help that much.
- Pete's conclusion at the end of the day: "Marek may try to build a high impedance differential amplifier, as he proposes."

"Tomorrow at noon I could install Marek's high impedance amplifier it in the RHIC tunnel."

- The night was for thinking and simple calculations.
- The morning was for looking for components and soldering.

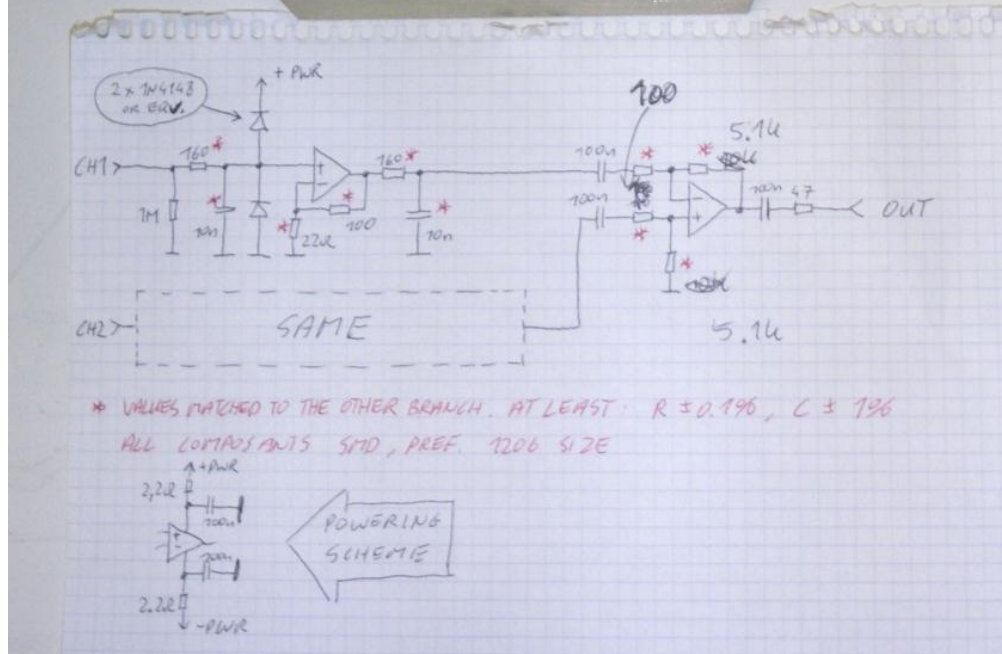
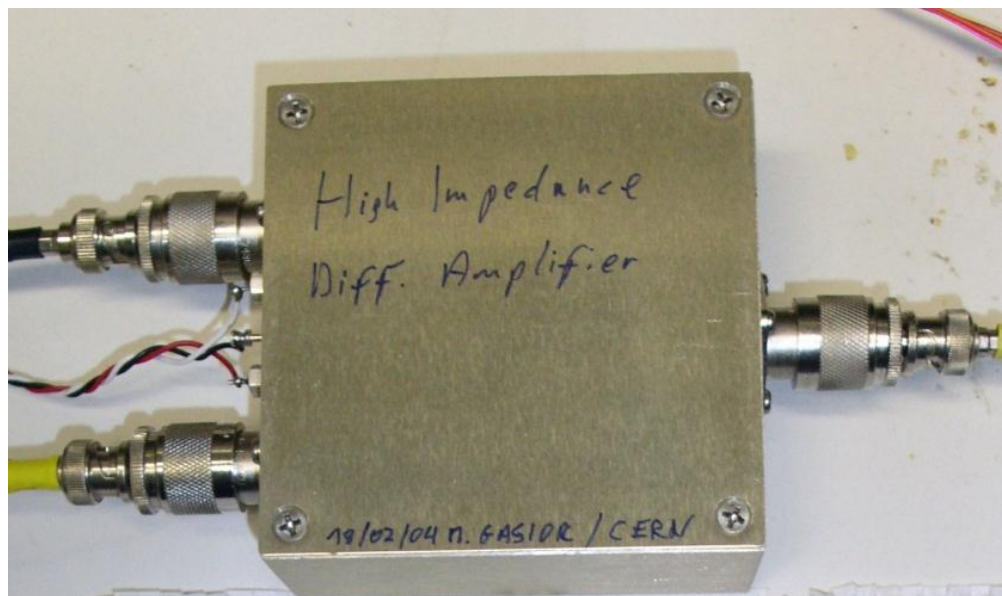
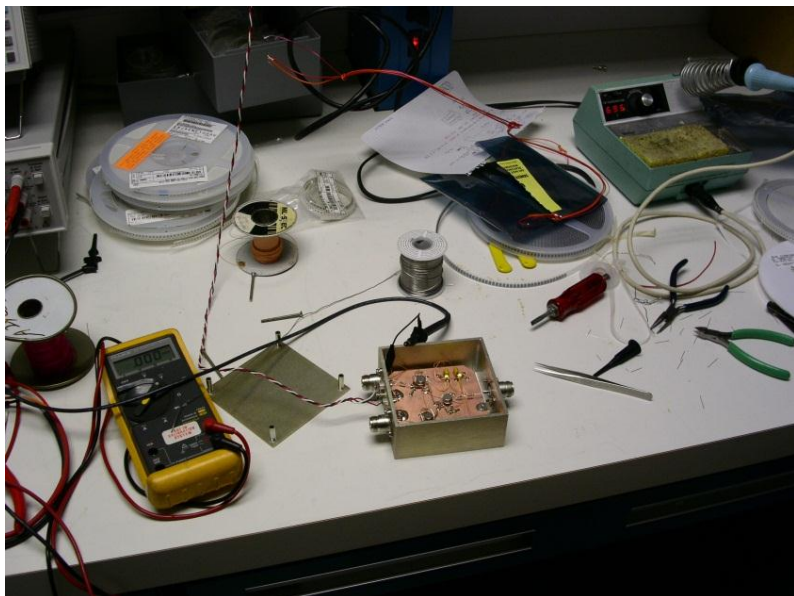

Advantages of the base-band system (RHIC: 10 – 40 kHz):

1. 24-bits: 24-bit digitisation possible.
2. Filter: filtering at audio frequencies is easy.
3. Better CMRR: consequence of operating at audio frequencies.
4. Don't need RF reference: because there is no mixers.
5. No phase compensation: consequence of working at low frequencies.
6. Resonant ???: resonant pick-up possible for single bunches.

① 24 bits
 ② filter
 ③ better CMRR
 ④ don't need RF reference
 ⑤ no ϕ comp
 ⑥ resonant
 - $\uparrow \uparrow \uparrow$

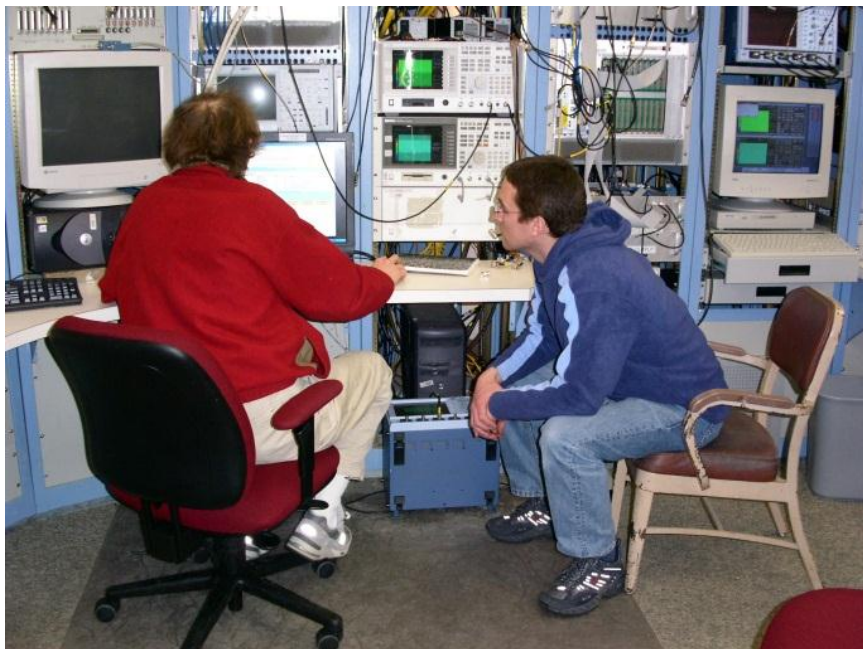

- The high-impedance differential amplifier was connected to 1 m stripline.
- The base-band PLL system was built using a lock-in amplifier, driving the FM tuning input of a generator.
- The beam was excited with 2 m stripline, working as a kicker.
- The used excitation power was in the order of 100 mW.
- The 245 MHz was operated in parallel for direct comparison.

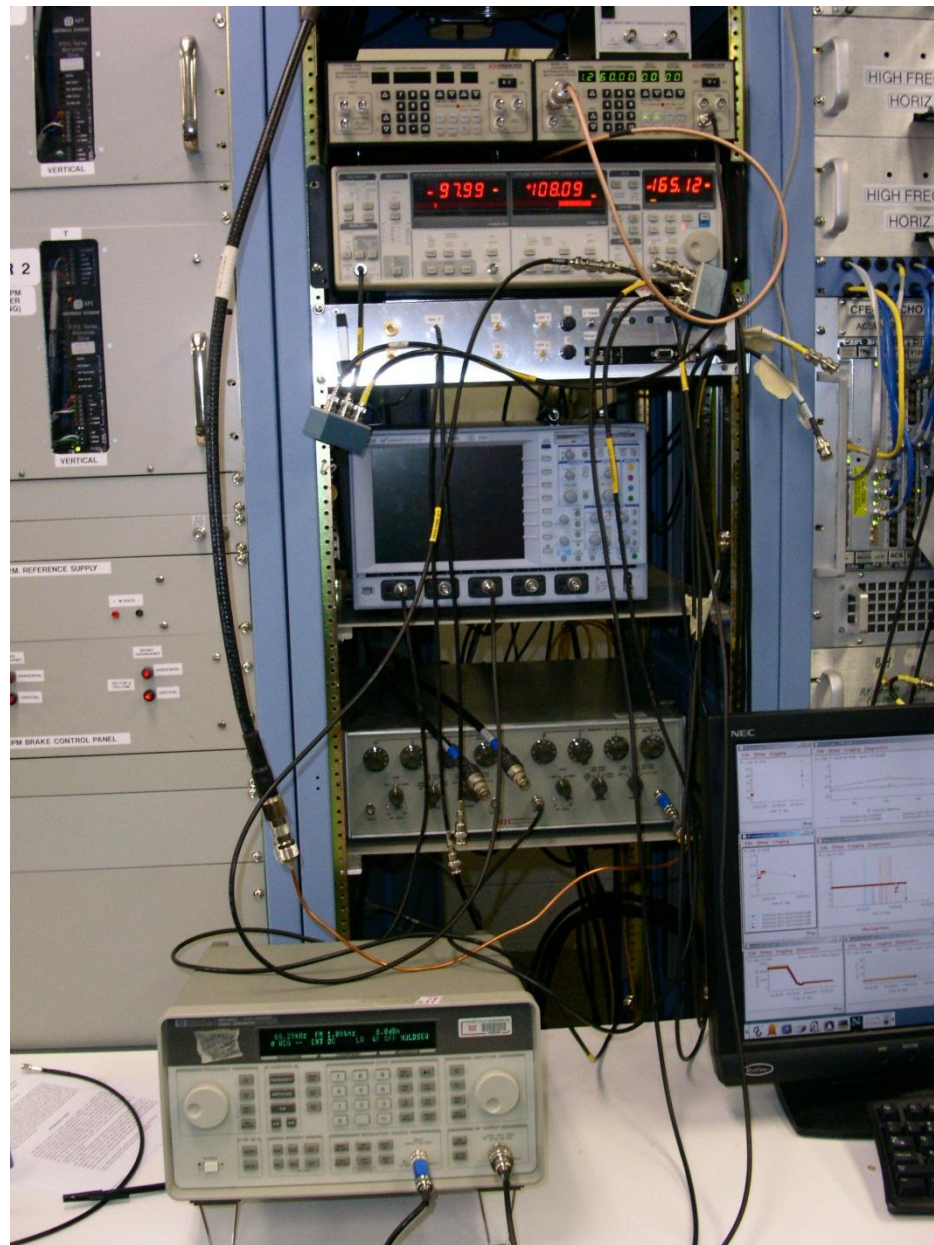

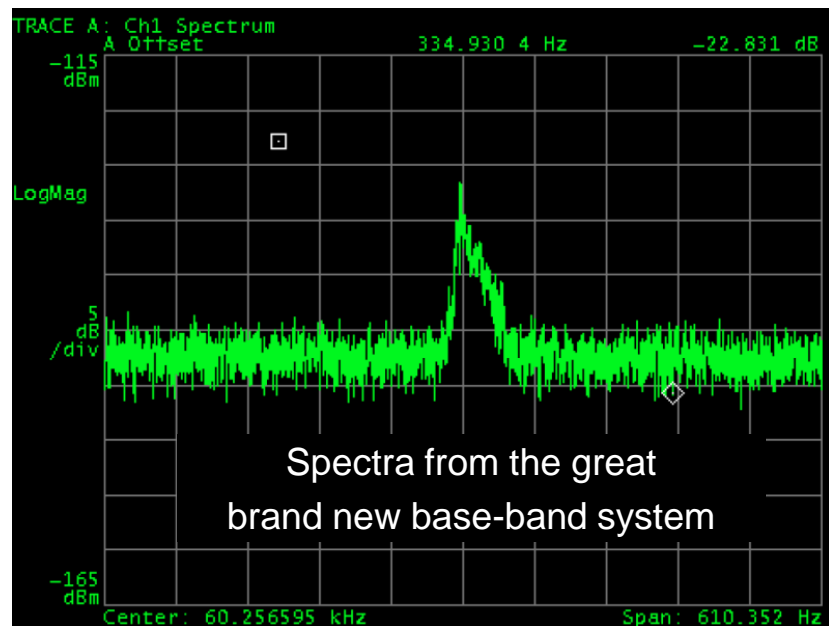
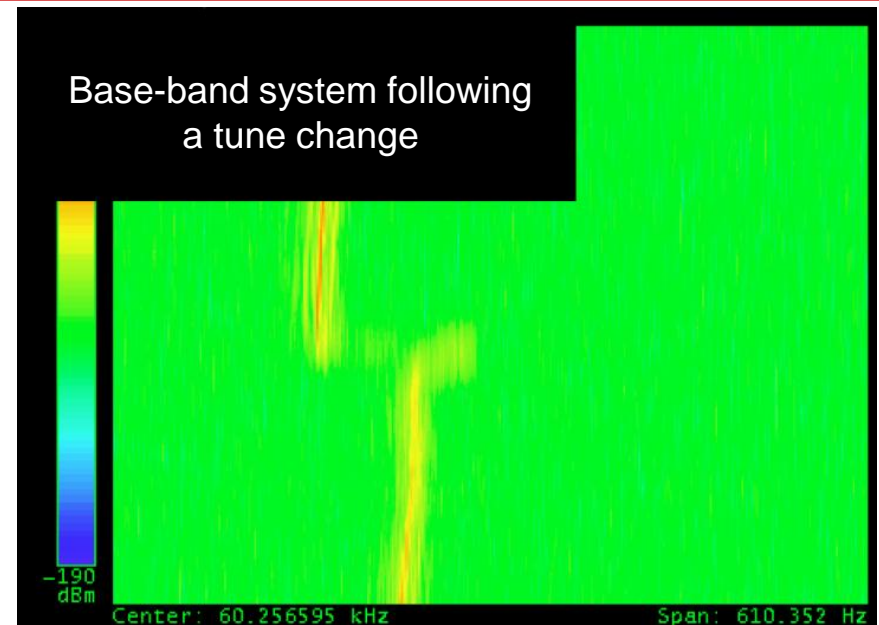
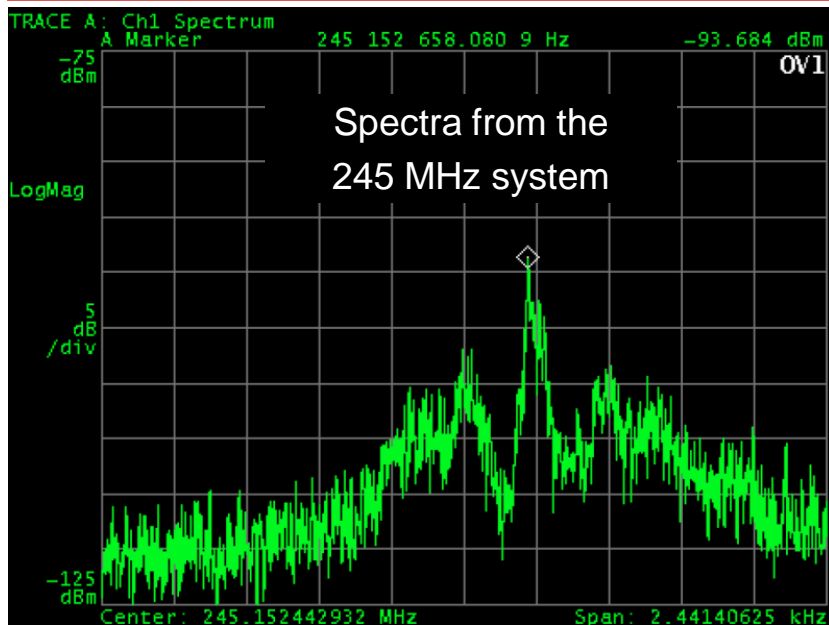

- The base-band PLL system was put into operation.
- The lock was achieved.
- The lock was confirmed by introducing a small tune step (in the order of 0.001), followed by the system.
- Right after the most important „tune step” measurement we rushed to the airport.

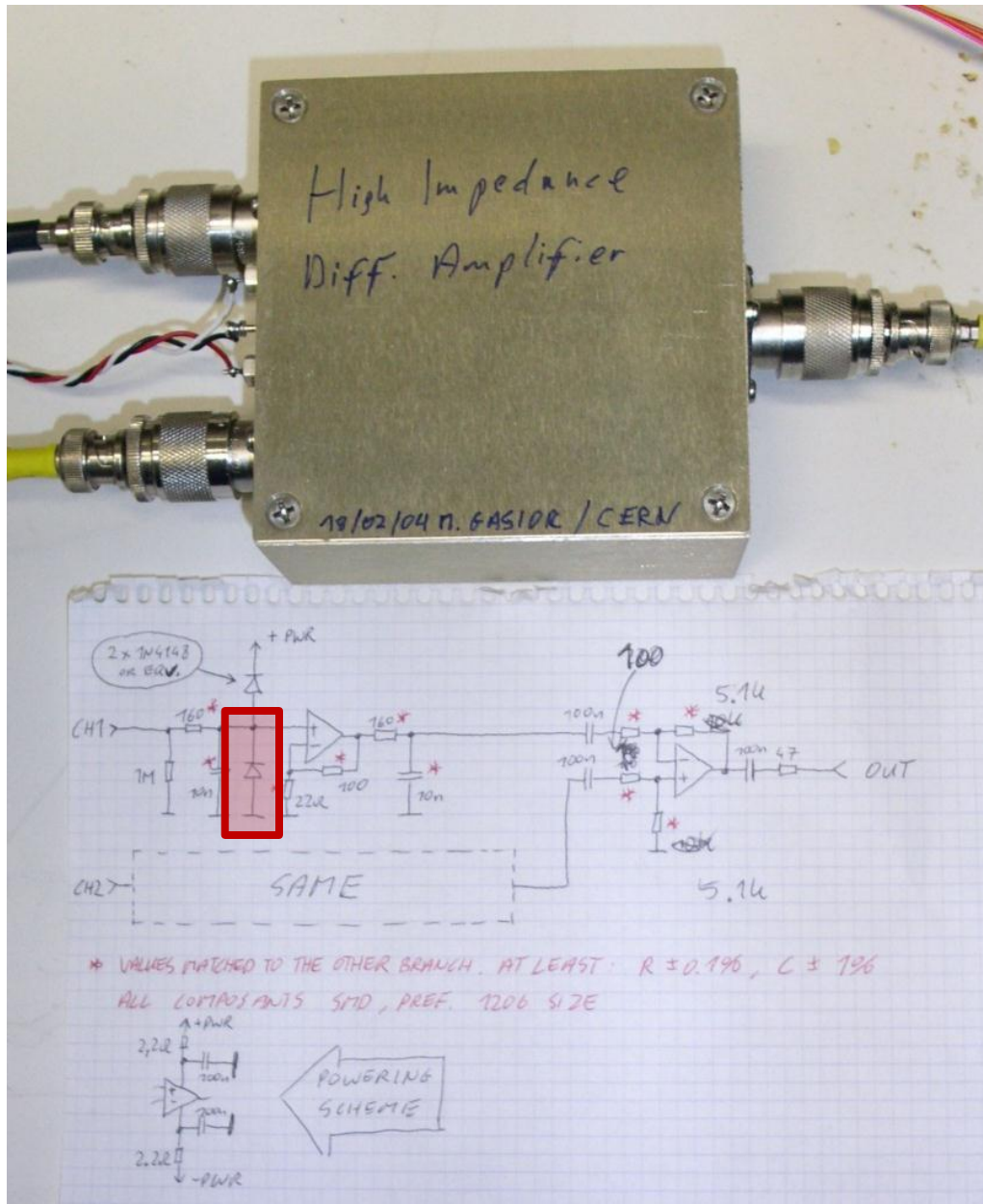

- On the input of the RHIC high impedance amplifier there were protecting diodes, connecting the input to the power supplies.
- On the schematic one diode was connected to ground. Such a configuration would make a diode detector. However, the diode in the built amplifier was in the standard protection configuration (seen on a photo of the amplifier).

▪ This error on the schematic triggered thinking about diode detectors.

- Reactions of the colleagues for the idea of measuring the tunes using diode detectors fitted generally between this two extreme ones:
 - “Great idea, should work !”
 - “Come on, too simple... If it worked, it would have been used before”.

BEAM DYNAMICS EXPERIMENTS AT SPEAR*

SLAC-PUB-1452
June 1974

Marek was 14 months old

The SPEAR Group†
Stanford Linear Accelerator Center, Stanford University, Stanford, California 94305

Introduction

The single-particle properties of beams in storage rings are well understood, but high density single and colliding beams suffer from a variety of instabilities due to self-forces and interactions with their surroundings. The chief experimental problems in the study of stored beams arise from the difficulty of devising beam-diagnostic probes which do not affect the stored beams or disturb the phenomena being studied, and which give unambiguous results when different phenomena act on the probes simultaneously.

In the SPEAR electron-positron storage ring, we have apparatus and methods for measuring center-of-mass motions of our beams on all three axes, as well as motions with higher moments. The shapes of the beam bunches can also be accurately measured. We will describe the techniques we have used to study instabilities and measure operating characteristics.

Center-Of-Mass Motions

There are directional antennas (striplines) inside the vacuum envelope¹ which detect the electromagnetic field of the whole bunch. When the beam executes betatron oscillations, there is a small amplitude modulation of the signals from the striplines. We detect and measure this modulation to give us information on betatron wave numbers, line strengths and widths.

The wave analyzer has an oscillator which automatically tracks the center of the receiver pass band. By connecting this oscillator to the beam excitation system and sweeping the receiver and exciter simultaneously, we observe directly resonant responses of the beam with freedom from harmonic or intermodulation responses. (Fig. 1). A similar technique has been used at the Bevatron,² to measure the phase response of the beam.

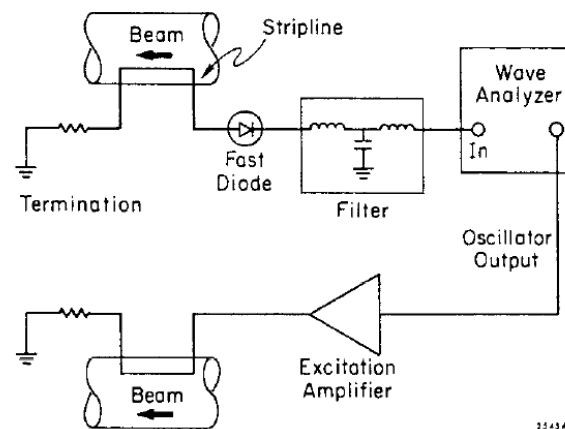
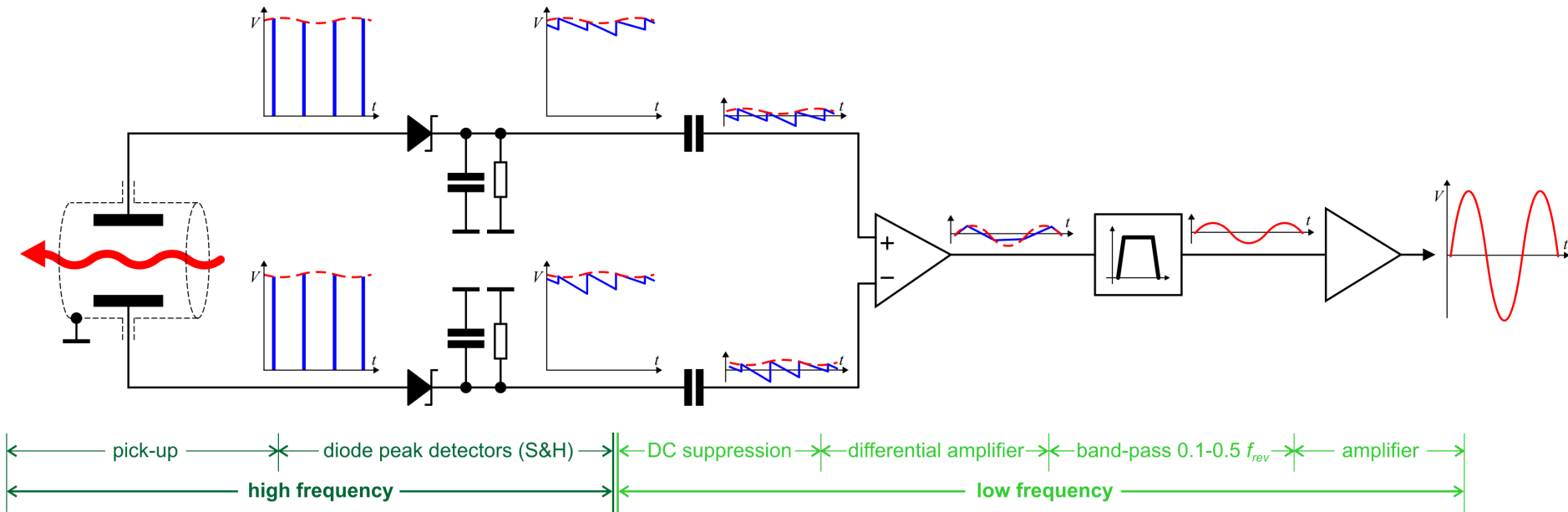
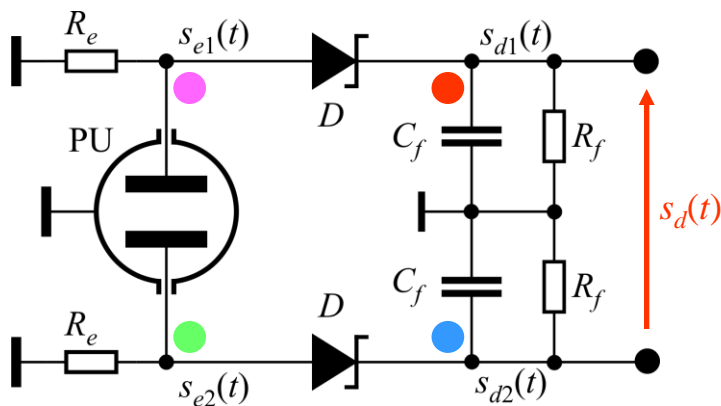

FIG. 1--The system for betatron and synchrotron-frequency response measurement. The oscillator is not used when observing self-excited lines.

- Diode detectors were used in the past, but with relatively low load.
- For a single 1 ns LHC bunch repeating every 89 μ s (duty cycle $\approx 10^{-5}$) low impedance load would spoil the idea.
- Load in the order of 10 M Ω was required. The question was how such a detector would behave in the presence of losses.



- Peak detection of signals from a position pick-up electrode, a simple sample-and-hold, with the sampling triggered by the beam pulses.
- An RF Schottky diode can handle up to 50 V of beam pulses; more is possible with a few diodes in series (LHC detectors have 6 diodes).
- Betatron modulation is downmixed to a low frequency range, as after the diodes the modulation is on much longer pulses.
- Revolution frequency background gets converted to the DC and removed by series capacitors, while the betatron modulation is passed for amplification and filtering (“collecting just the cream”).
- Most of the betatron modulation amplitude is passed to the following circuitry, resulting in very high sensitivity of the method.
- The diode detectors can be put on any position pick-up.
- Low frequency operation after the diodes allows:
 - very efficient signal conditioning and processing with powerful components for low frequencies;
 - using 24-bit inexpensive audio ADCs (160 dB dynamic range possible).
- What is new with respect to the classical peak detectors used in the past for BI applications:
 - Slow discharge, in the order of 1 % per turn (for LHC 100 M Ω resistors required).
 - Usage of high impedance amplifiers, not easy to build in the past if low noise was required.
 - Brutal filtering to the band 0.1 – 0.5 of f_{rev}
 - Notch filter for the first f_{rev} harmonic, resulting in the total f_{rev} attenuation beyond 100 dB.



$$s_{e1}(t) = s_b(t)(1 + \alpha)(1 + \beta \cos(2\pi f_b t))$$

$$s_{e2}(t) = s_b(t)(1 - \alpha)(1 - \beta \cos(2\pi f_b t))$$

Simulation parameters:

beam relative offset $\alpha = 0.1$

betatron oscillation relative amplitude $\beta = 0.05$

simulated tune value $q = 0.1$

filter time constant $\tau = 10T$ (T – revolution period)

storage capacitor $C_f = C_{pu}$ (PU electrode capacitance)

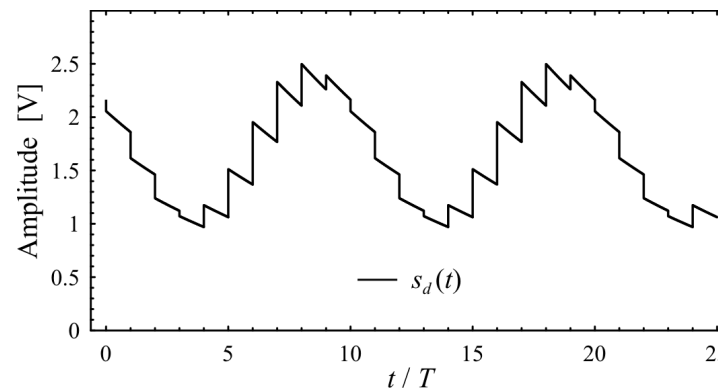
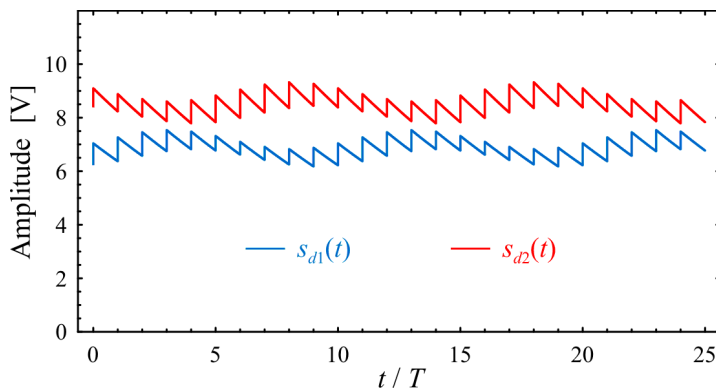
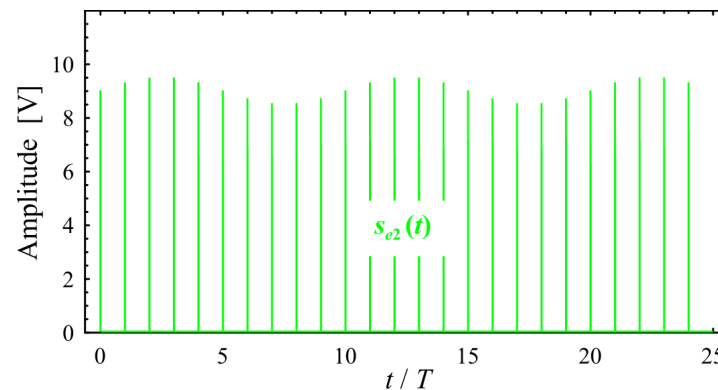
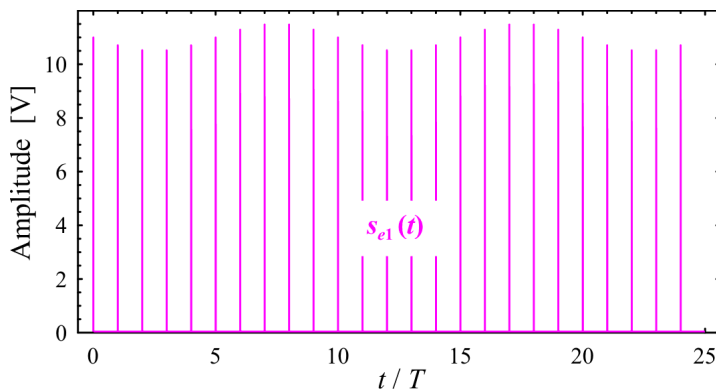

signals on the detector outputs

detector signal difference

Simulation parameters:

$\alpha = 0, \beta = 0.01$
 $q = 0.1, C_f = C_{pu}$

$\tau = T$

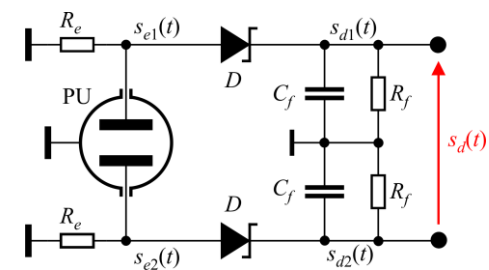

$\tau = 100 T$

4 bunches
 $\tau = 100 T$

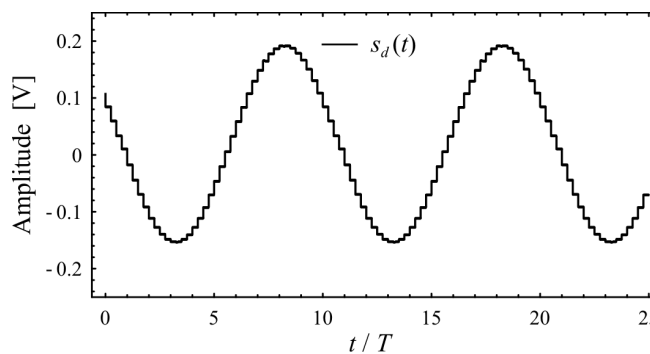
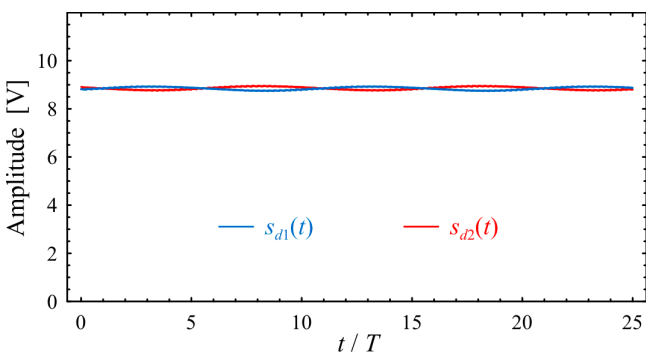
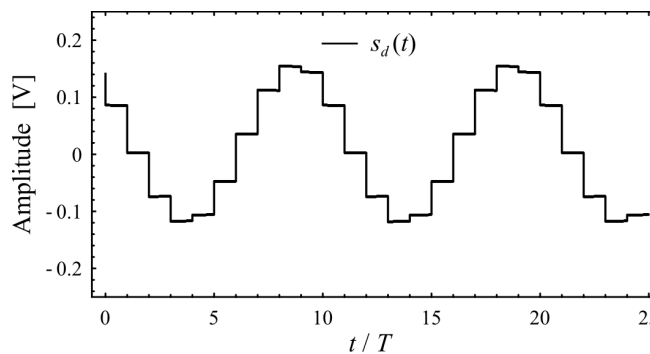
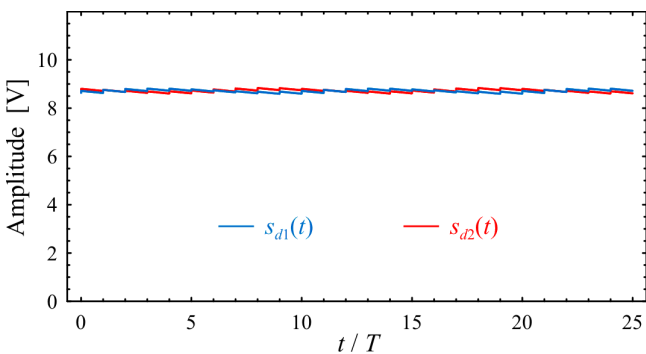
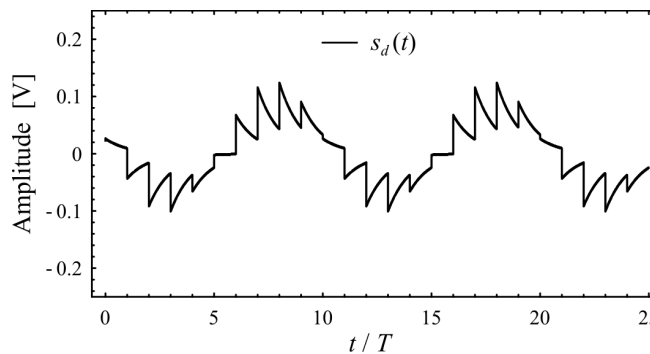
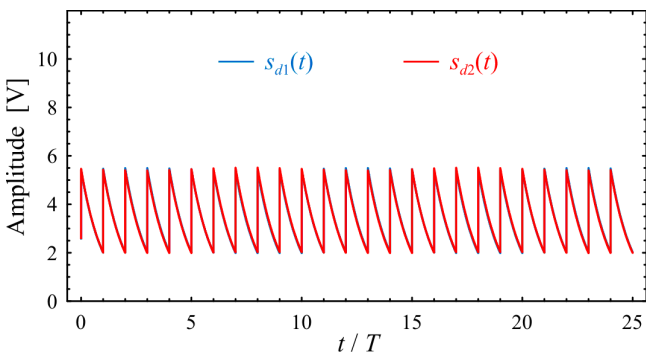

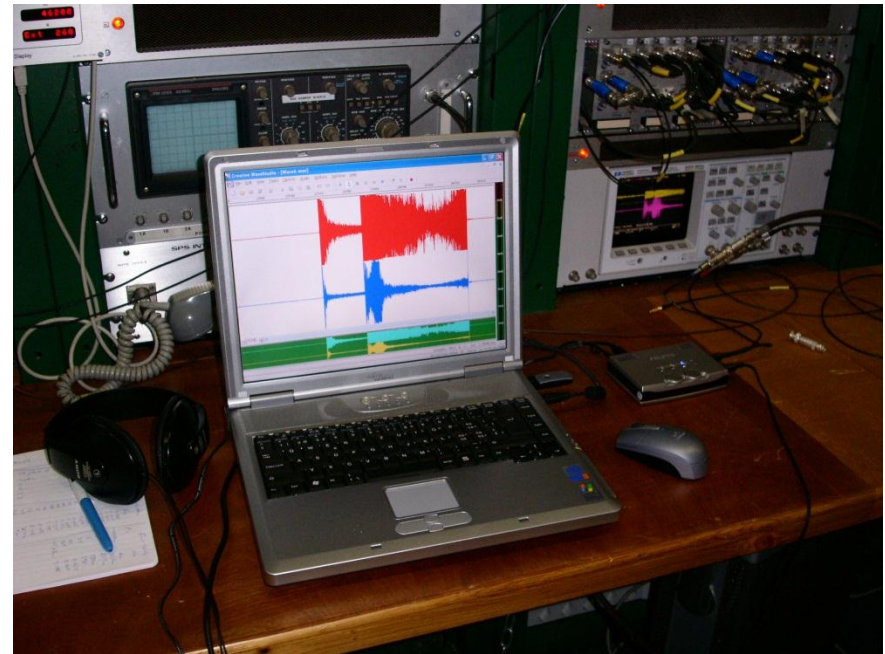
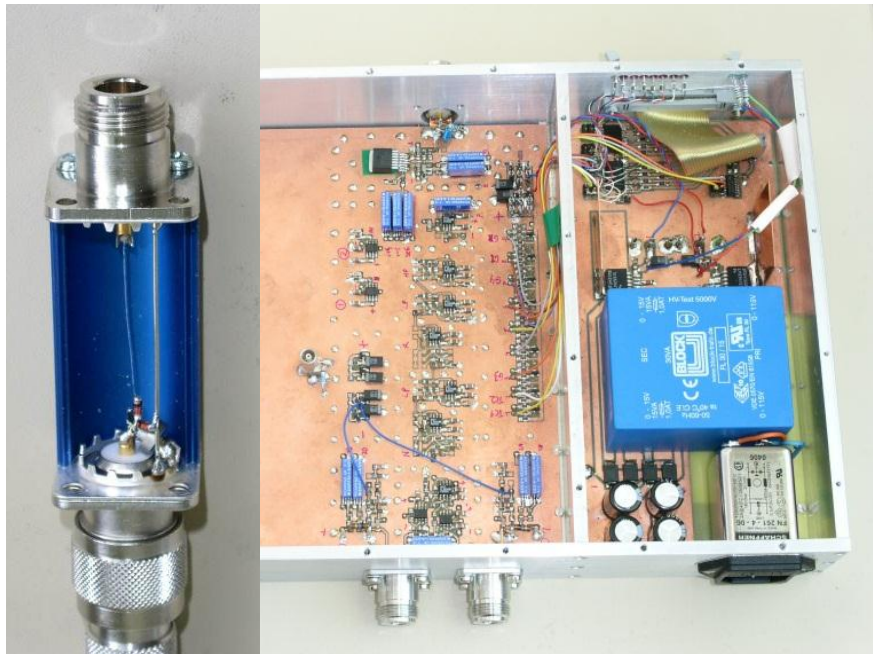
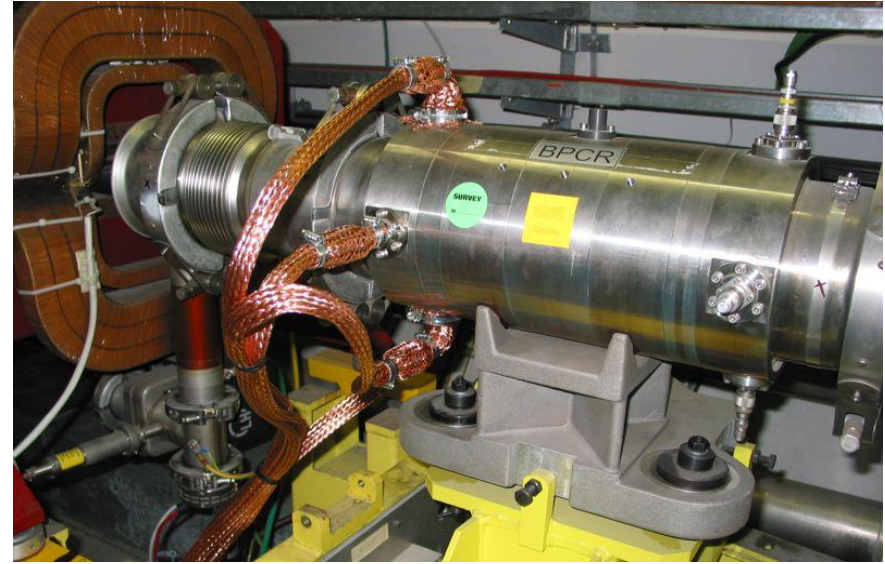

[Home](#) >> [Professional](#) >> [3D-BBQ](#)

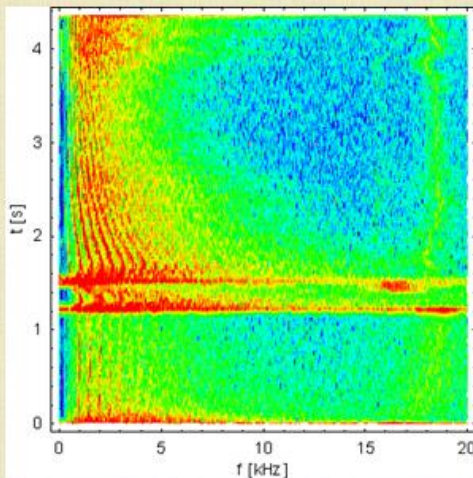
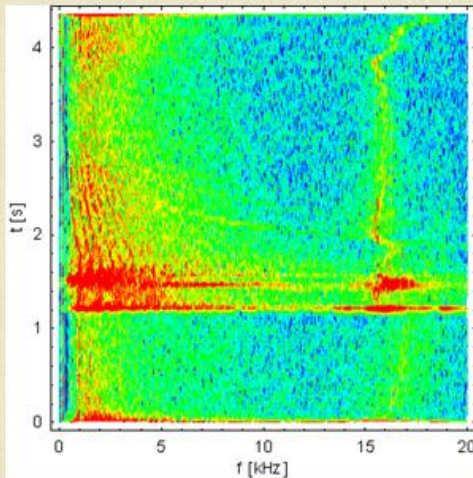

Base-Band Q (BBQ) Measurement with Direct Diode Detection (3D)

- [Principles and the first hardware](#)
- [Some early SPS results](#)
- [A few early PS results](#)
- [A measurement from RHIC](#)

The plots to the left show spectra of the SPS fixed target beam. The upper and lower plots correspond to the horizontal (H) and vertical (V) planes, respectively. The plots present spectra of signals given by the 3D-BBQ-Measurement prototype **WITHOUT ANY EXTERNAL EXCITATION** of the beam. The signals were acquired with a PC sound card and processed off-line. Go to the [SPS Results](#) for further details.

The signals whose spectra are seen can be downloaded as a .wav file and **THEY CAN BE LISTENED TO!** The left (L) channel contains the record of the H plane signal and the right (R) channel - of the V plane. The .wav file can be downloaded from the list below.

The lower frequency content (left side parts of the plots) corresponds to the synchrotron motion of the beam and the traces above 15kHz - to the betatron motion. Since the betatron frequencies are above 15kHz, they cannot be heard easily in the original record. For this reason I prepared versions of the record, which are stretched in time 4 times to reduce all frequencies by the same factor. The longer machine cycle helps also to follow what happens with the synchrotron frequencies.

I prepared two .wav files, containing separated H and V signal records, each copied to both, R and L channels. The .wav files can be downloaded from the list below. **Headphones help a lot to resolve different components.**

- [Original .wav file \(ca 1.6MB, 16-bit, 96kS/s, ca 425kS, 4.4s\).](#)
- [4-times stretched time scale - H plane \(ca 1.6MB, 24kS/s\).](#)
- [4-times stretched time scale - V plane \(ca 1.6MB, 24kS/s\).](#)



(c) M.Gasior, CERN-BE-BI. All rights reserved.

- It came the time to broadcast the results so the system needed a name.
- BBQ was good, except once, when it appeared on shipment documents for the front-end box sent to BNL. It took a bit of time to explain to the customs that this is not food related stuff. Finally the box came to Pete after more than a month.
- The small website www.cern.ch/gasior/pro/BBQ/index.html with some early BBQ sound records and results is still operational.

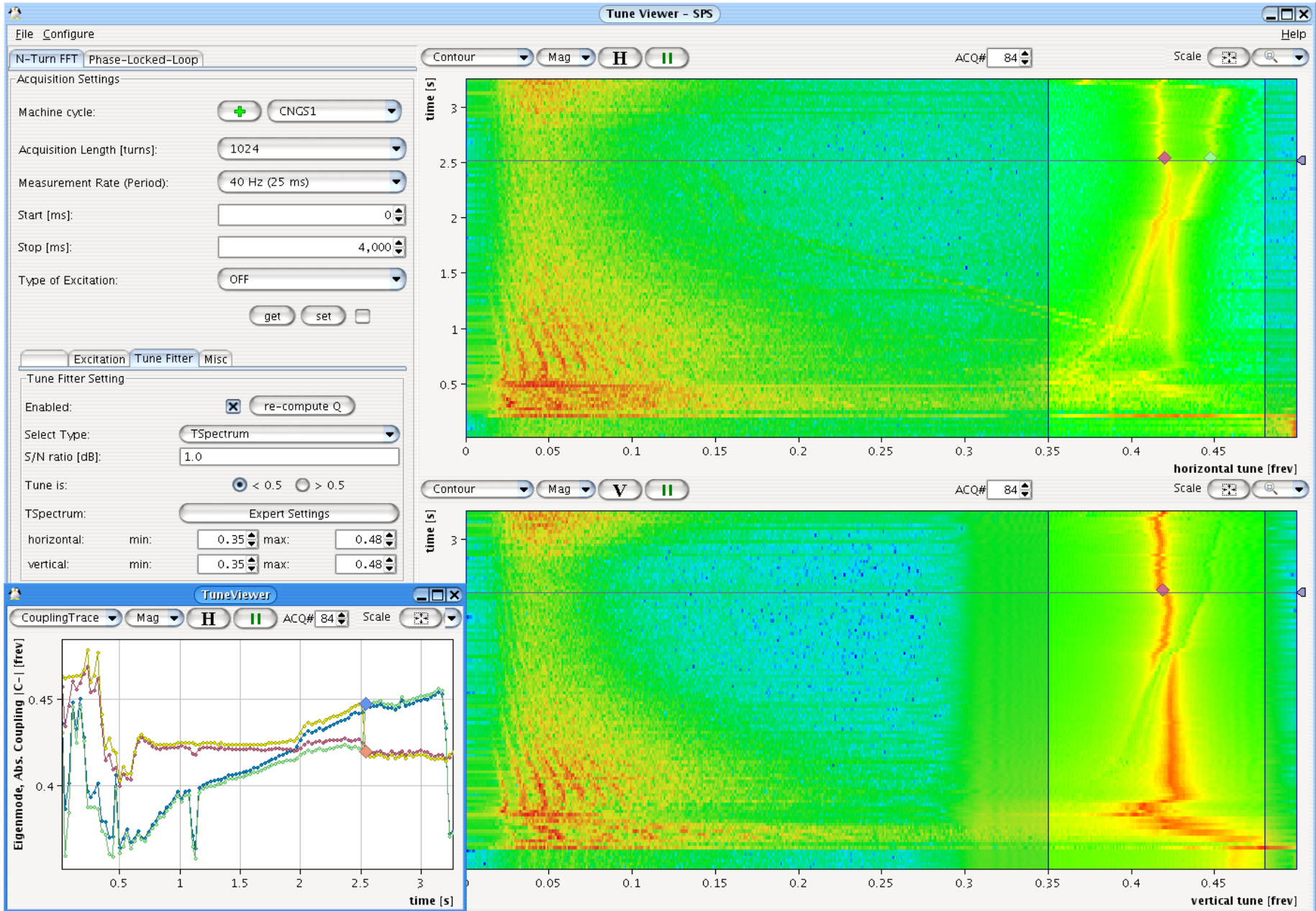

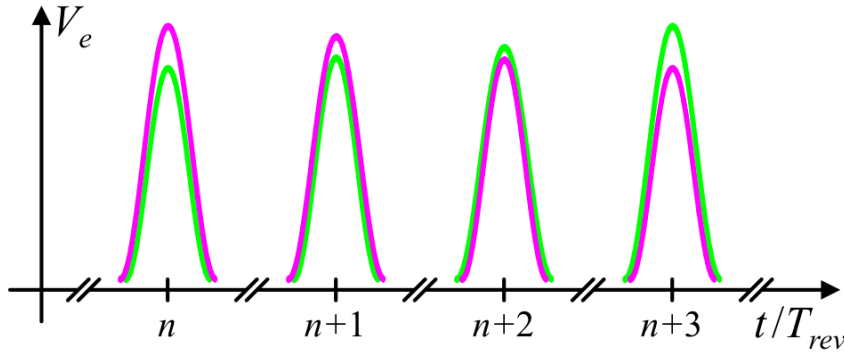

- BPM electrode signals for TRANSVERSE beam motion (betatron oscillations).
- Classical amplitude modulation of the electrode signals.
- If one signal becomes larger, the second becomes smaller.

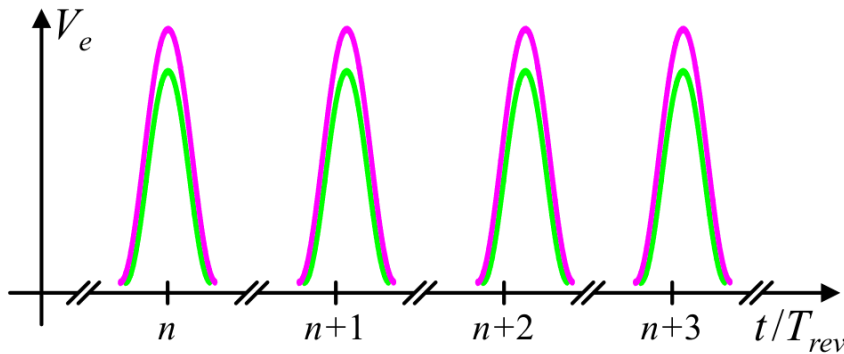

- BPM electrode signals for LONGITUDINAL beam motion (synchrotron oscillations).
- Classical phase modulation of the electrode signals.
- The signal amplitude does not change.

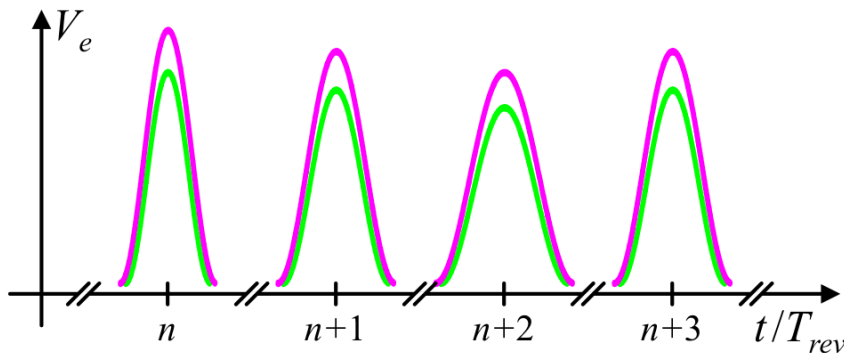

- BPM electrode signals for BUNCH LENGTH oscillation.
- Signal amplitude modulation related to the longitudinal beam dynamics.

In practice beam motion is a SUPERPOSITION of all those three modes

180 Hz

360 Hz

720 Hz



BBQ near transition

Million turn BPM near transition

The BBQ sensitivity was estimated to be better than 10 nm

5000 16000 17000 18000 19000 f [Hz]

Measurement by P. Cameron

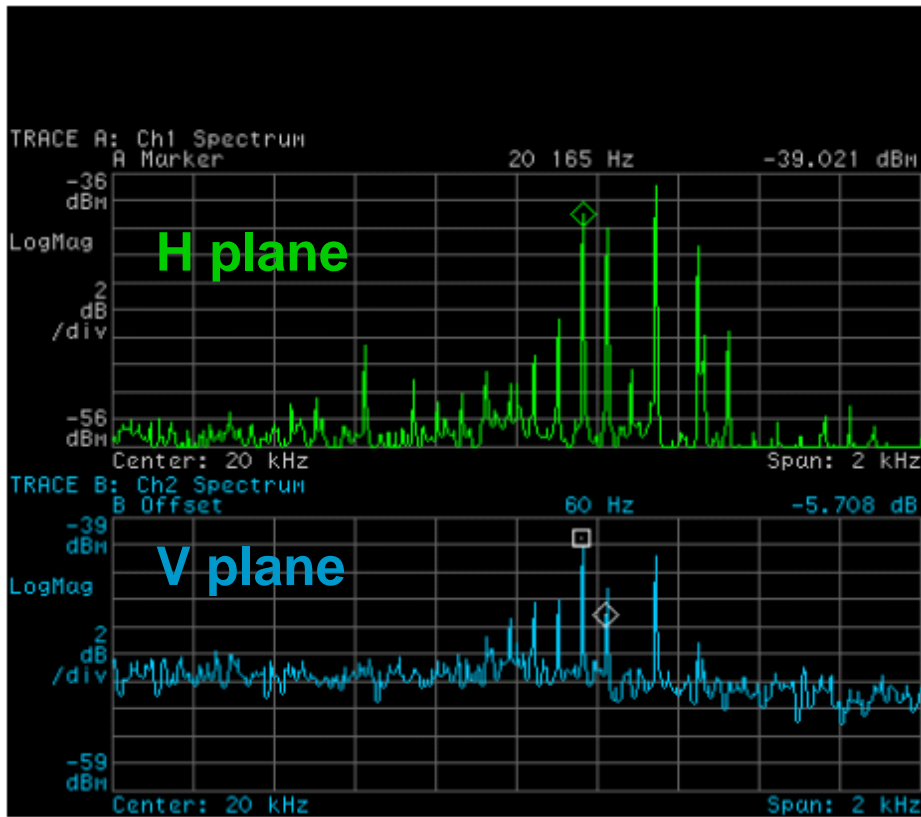

BBQ front-end on its built-in power supply

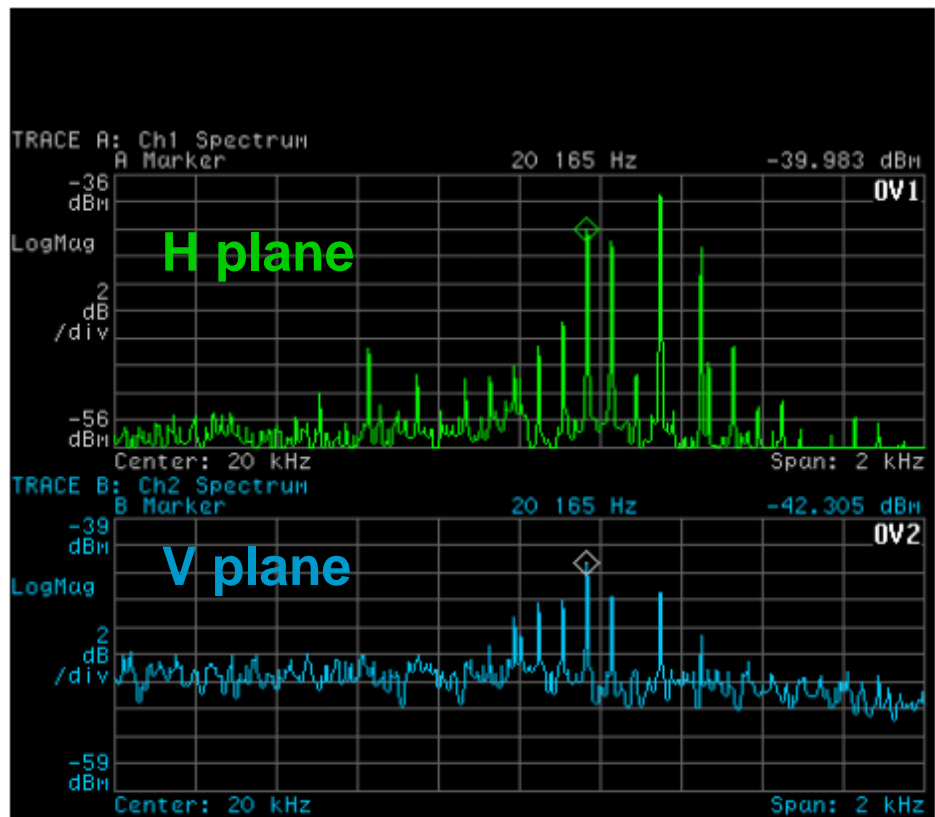

BBQ front-end on batteries

Measurement by C.-Y. Tan (FNAL)

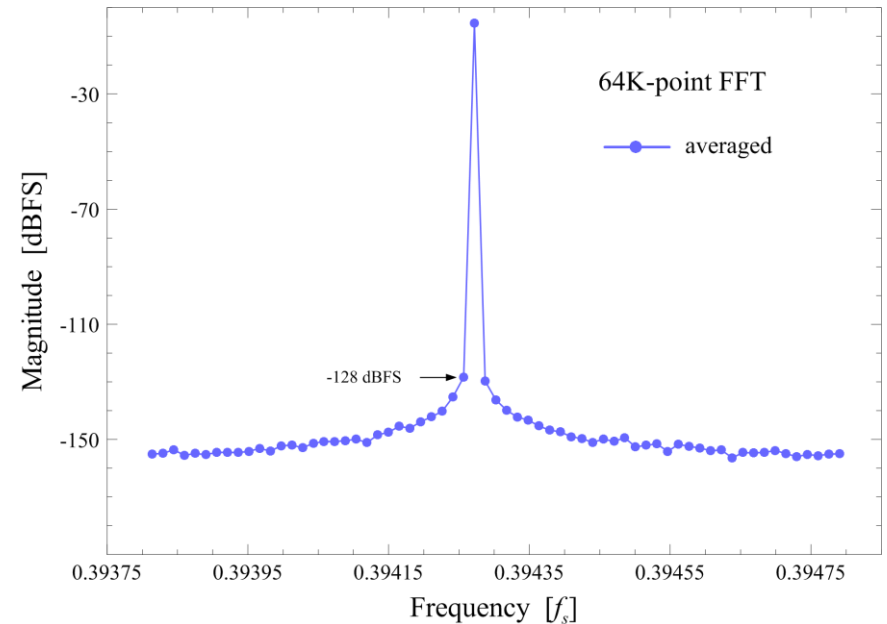
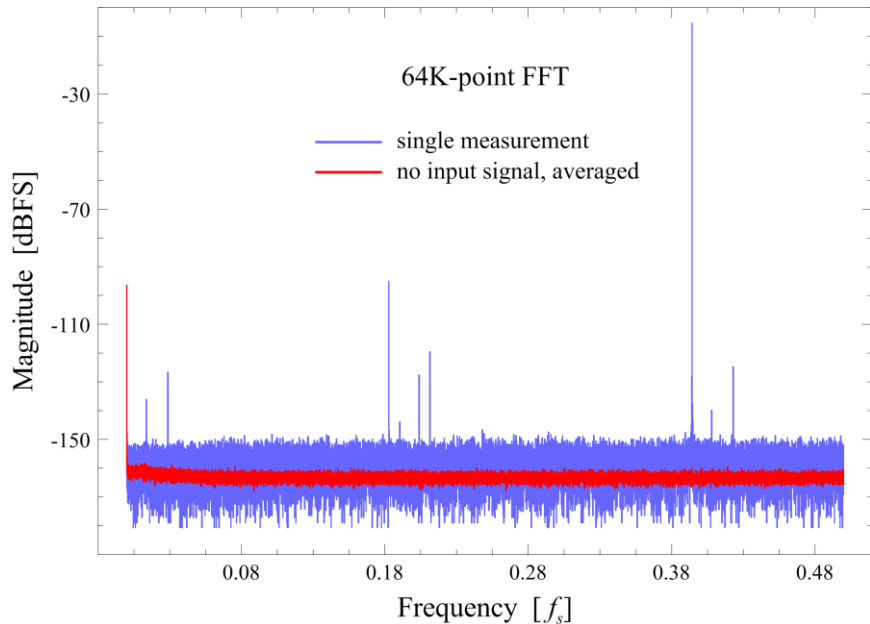
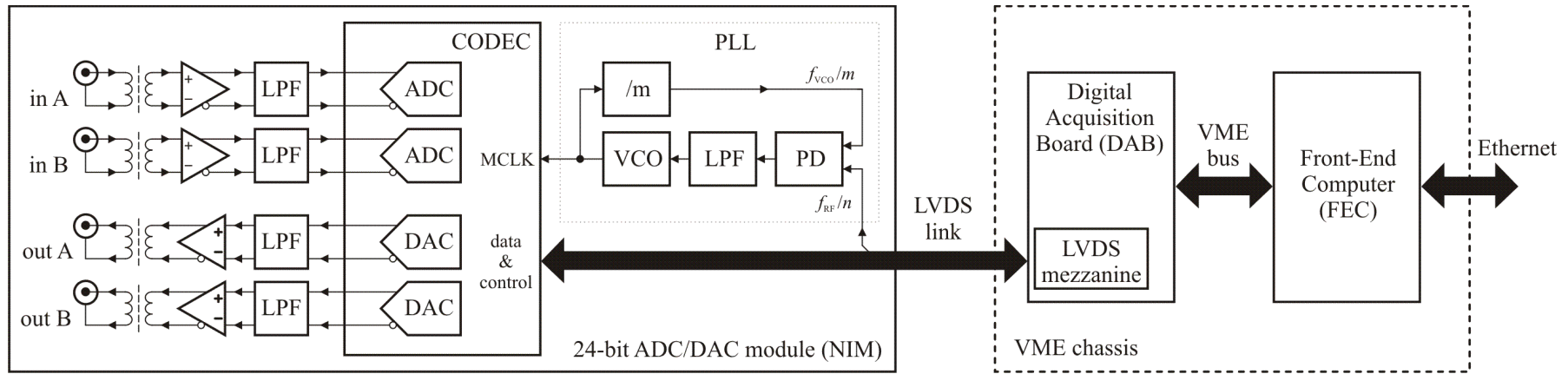

- Sound card was good for studies, but we needed a 24-bit ADC/DAC module integrated to the VME world of the CERN control system.
- 3rd key person: **Andrea Boccardi**.
- FPGA processing of ADC samples, integer arithmetic with on-line sine/cosine calculation, 180 dB dynamic range FFTs.

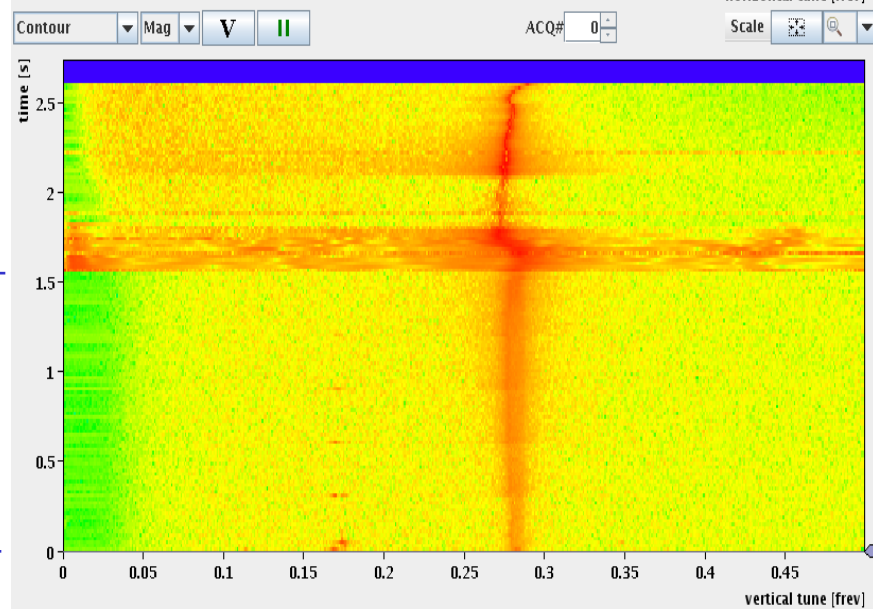
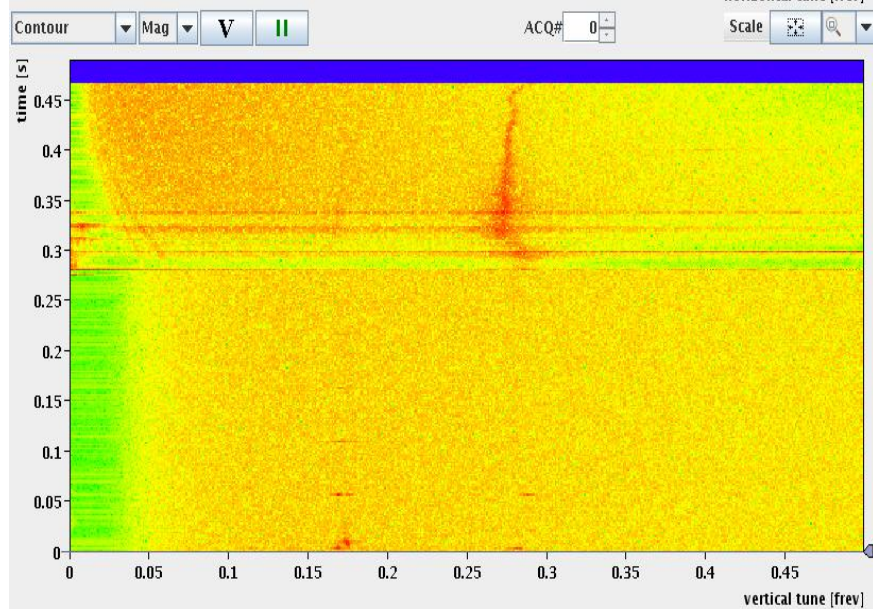
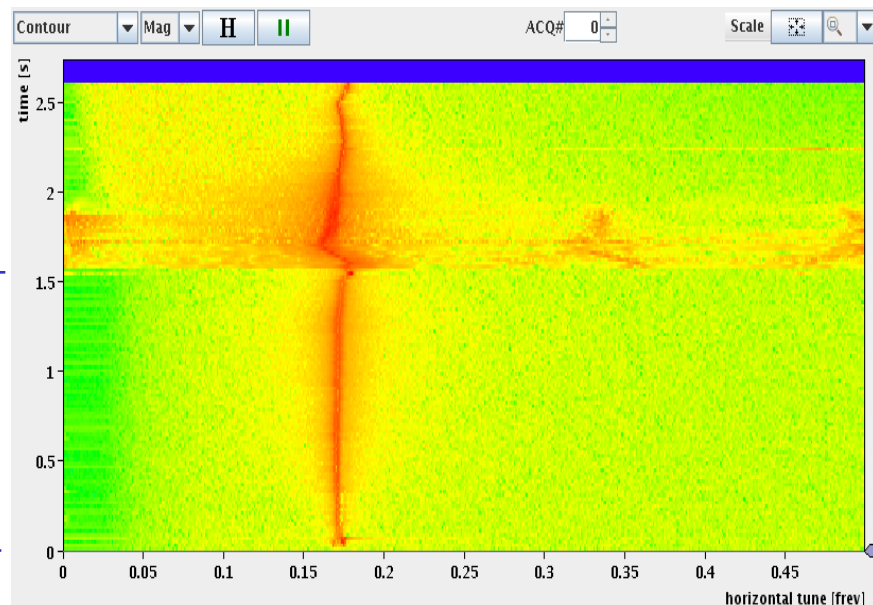
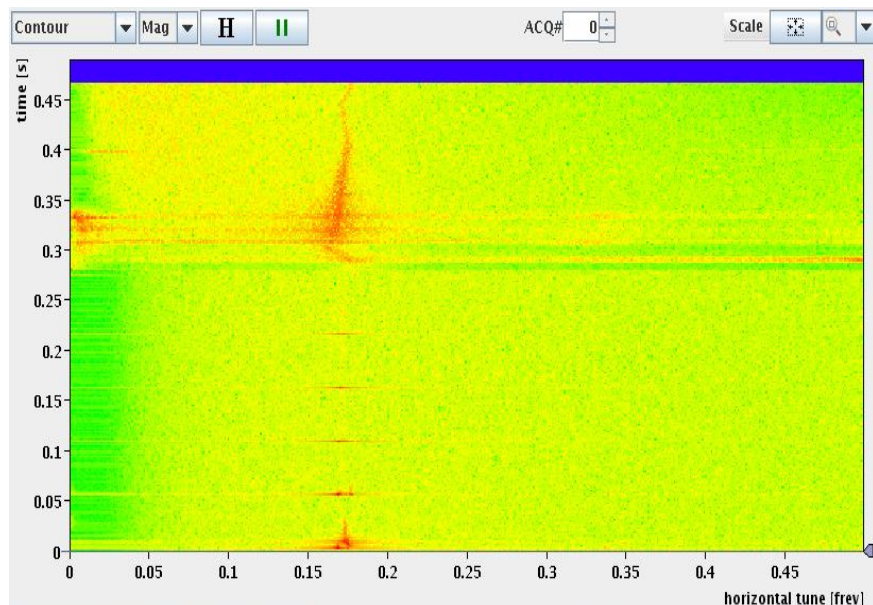

Cycle "NOMINAL", no excitation

NOMINAL, regular kick 500 V, every 10 ms

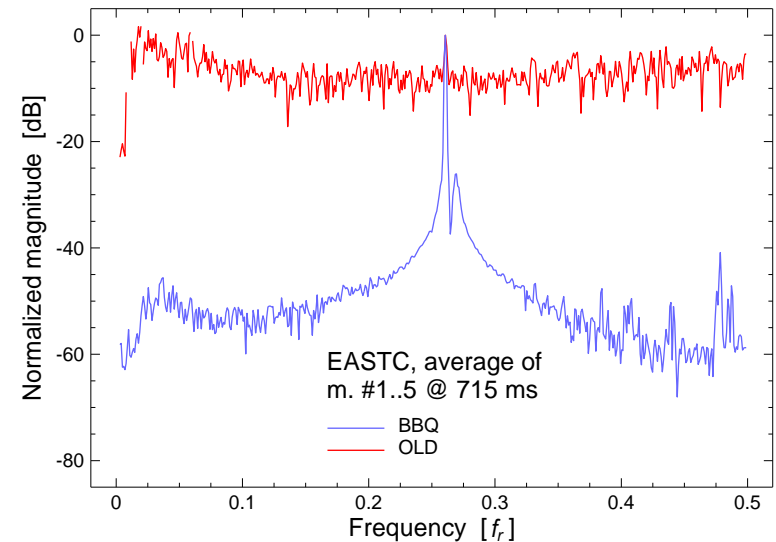
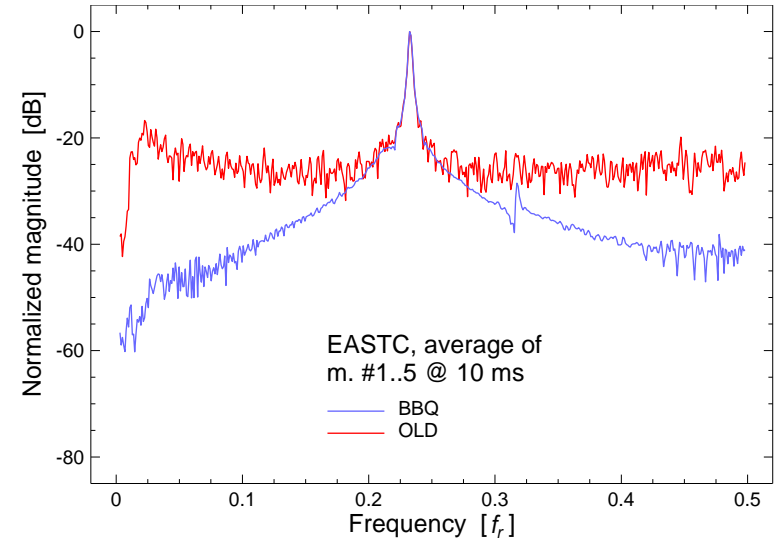
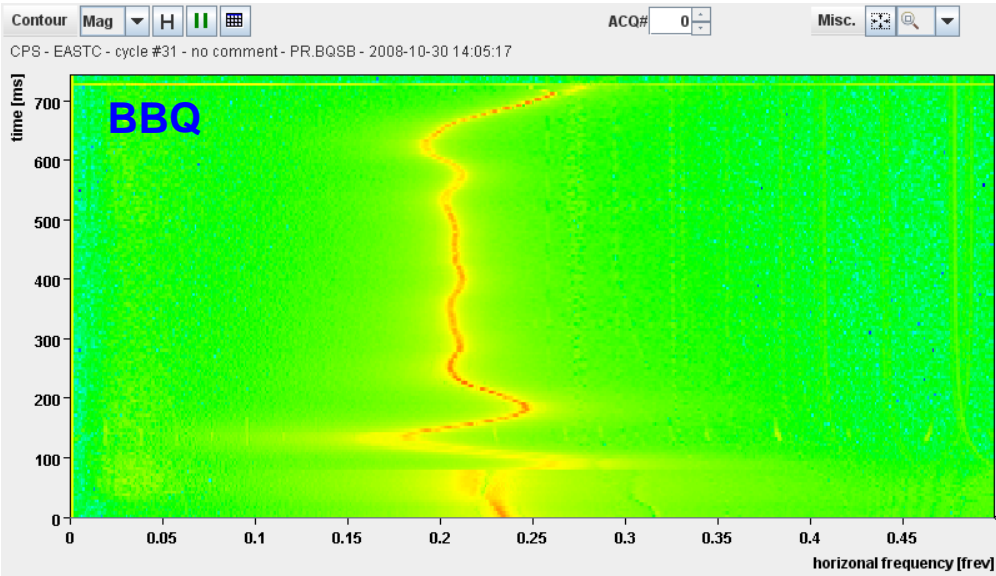

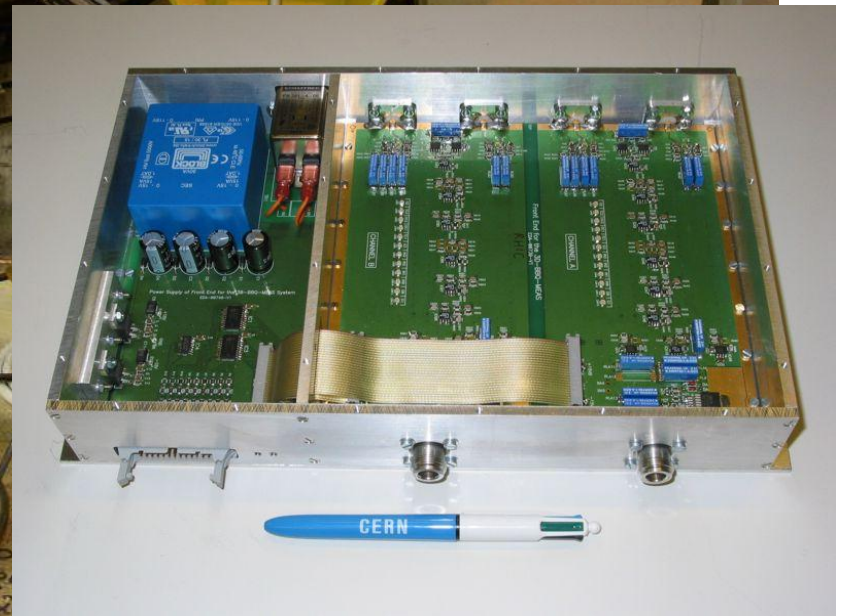
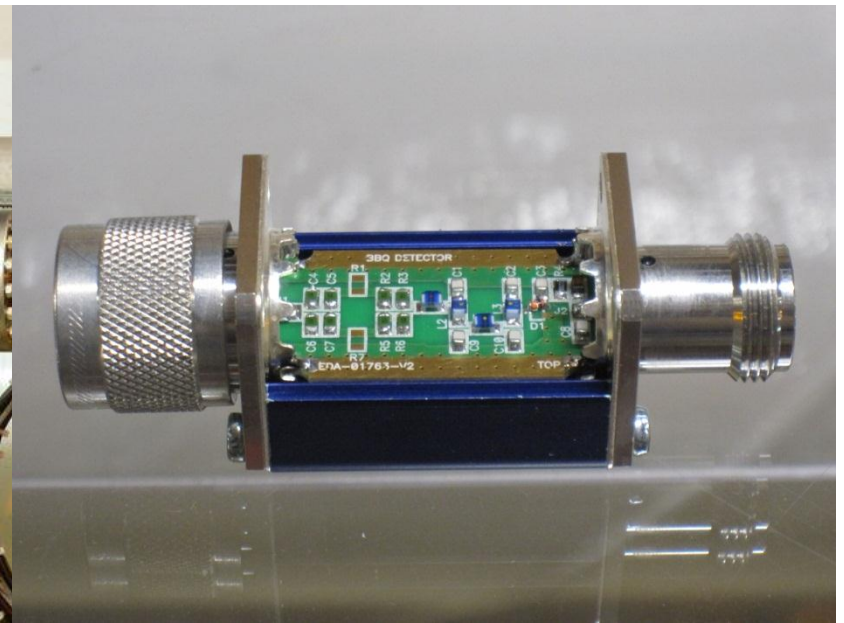
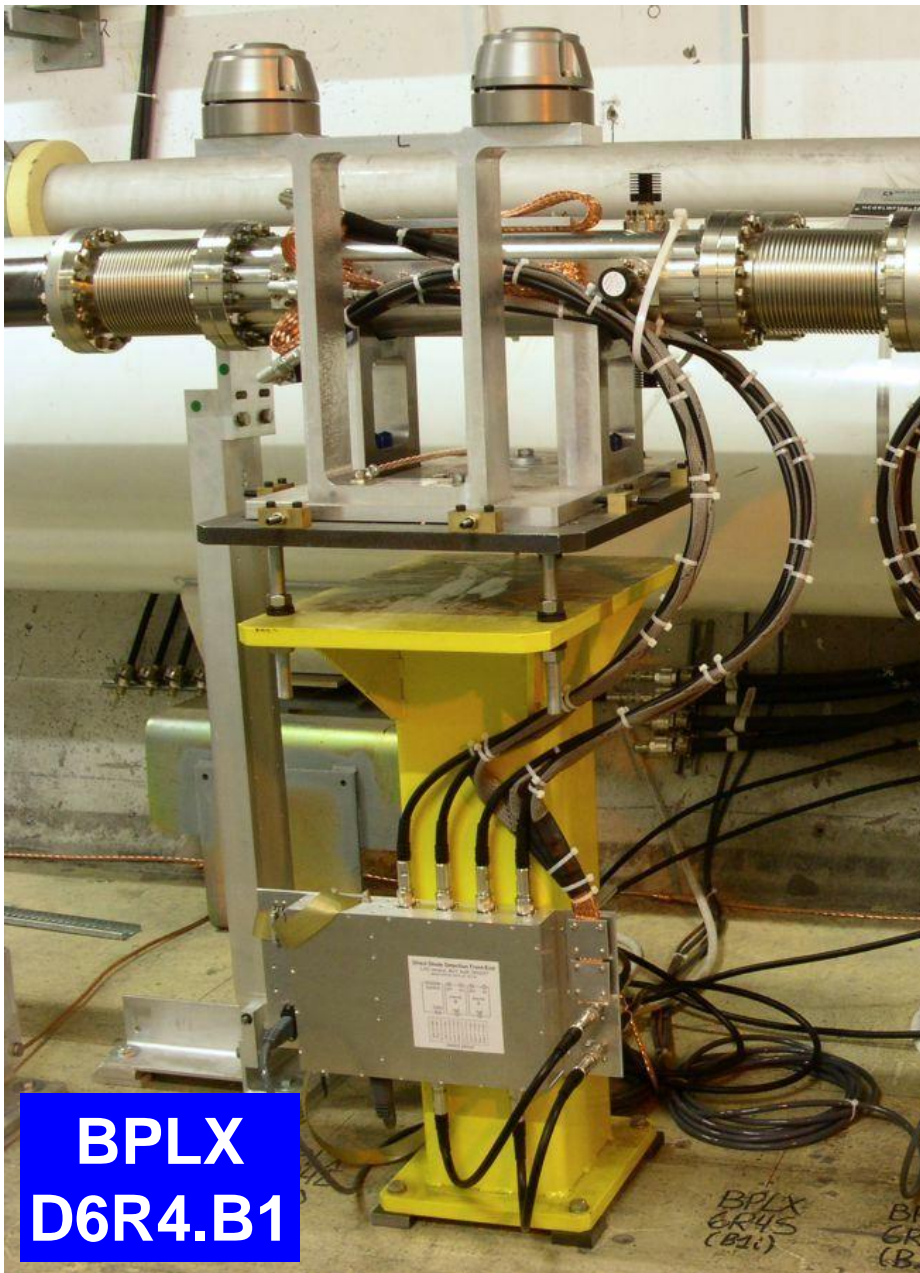

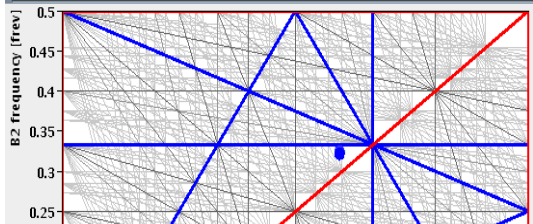
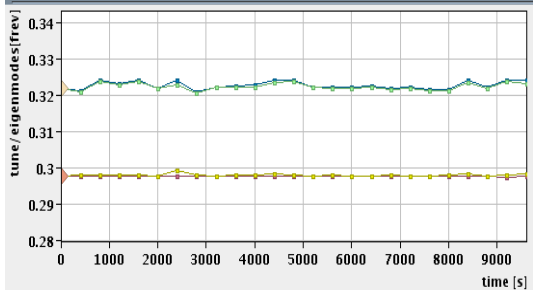
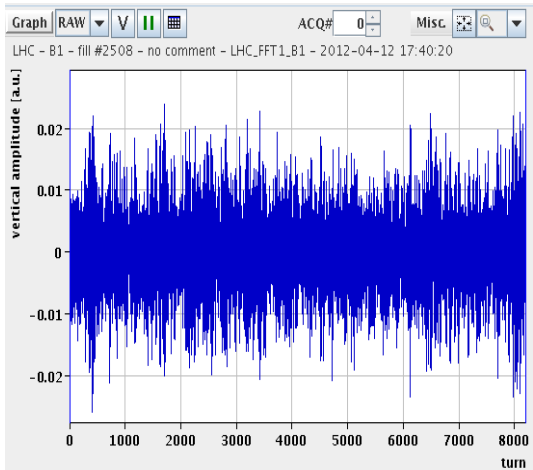

File Edit Run Timing Configure Fitter Settings Help

RBA: mgasior User: LHC **STABLE** On-Demand B1 (FFT1.B1) LHC.OFSI Tune-FB: OFF <H> <V>

Info FFT DataSets Q' FB/Trim Orbit Contour Mag V

Q-FPGA Tune Measurements

LHC - B1 - Fill#2508.0
 2012-04-12 17:40:20
 RAW&FFT: 8192 turns@2.5Hz
 no excitation
 $Q_1 = .297812$ $Q_x = .297852$
 $Q_2 = .321998$ $Q_y = .321958$
 $|C-| = .001978$ $E = 4000.0$ GeV
 $Q'_x = ???$
 $Q'_y = ???$

Spawn TuneViewer Display

Comments:

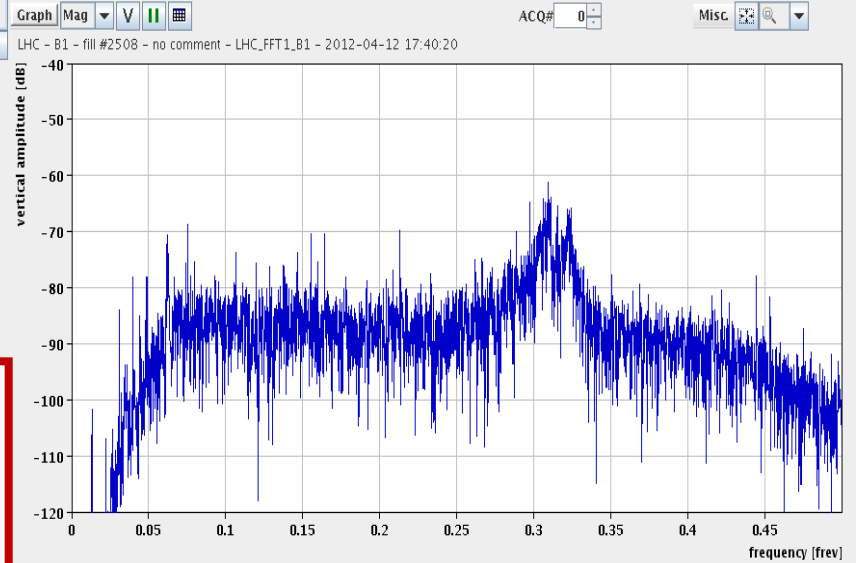
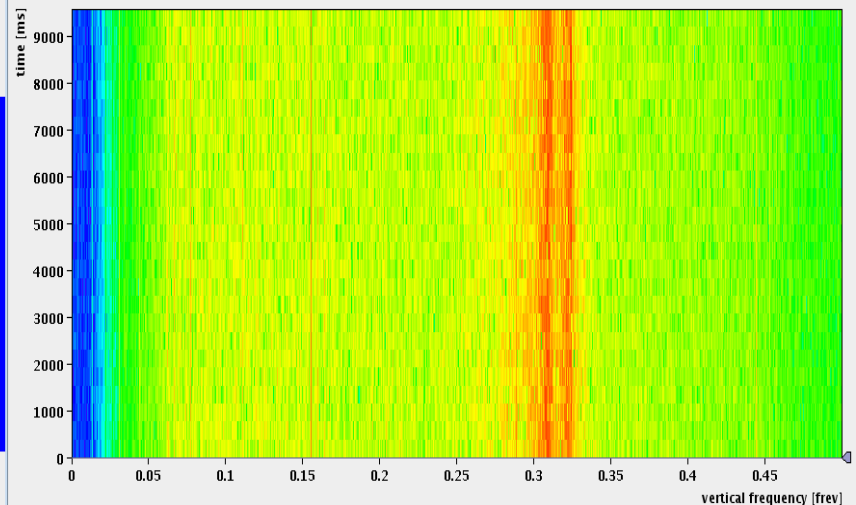

- A beam instrument is always seen from the control room through a software window.
- “The chain is as strong as its weakest element”.
- 4th key person: **Ralph Steinhagen**.

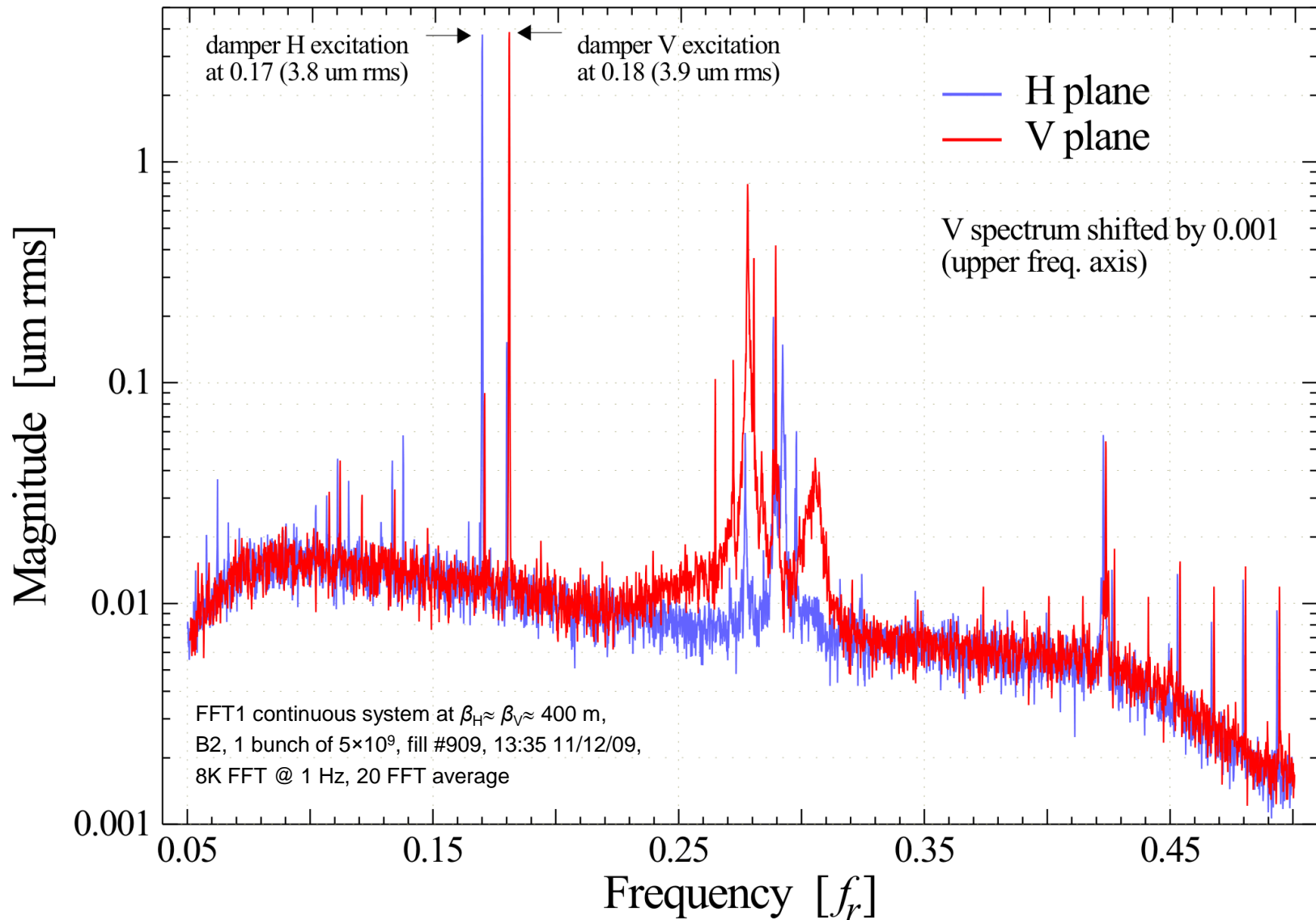

- Absolute amplitude calibration was done by exciting the beam to the amplitudes seen by regular LHC BPMs.

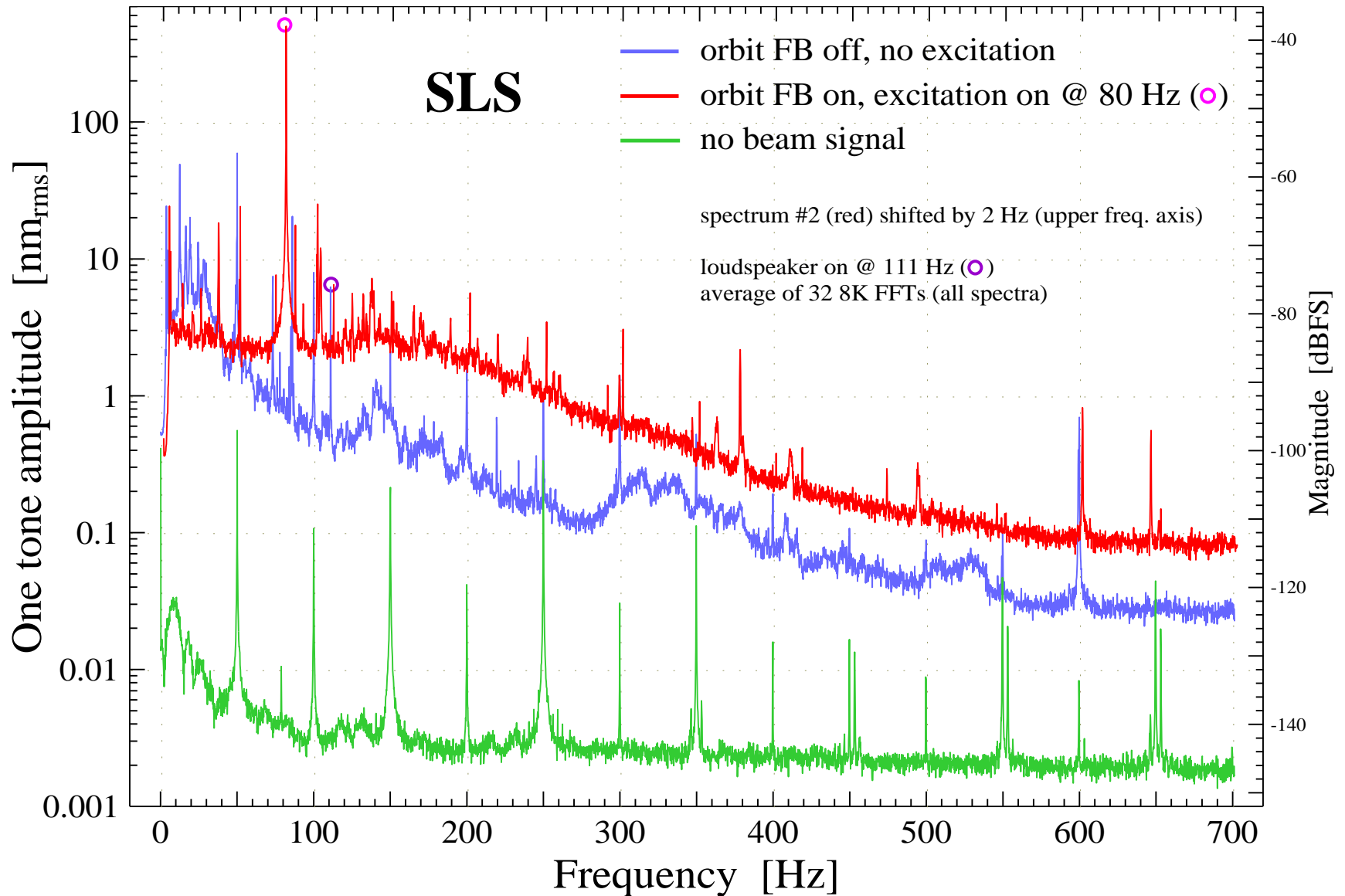

- Absolute amplitude calibration was done by exciting the beam to the amplitudes seen by regular SLS BPMs.

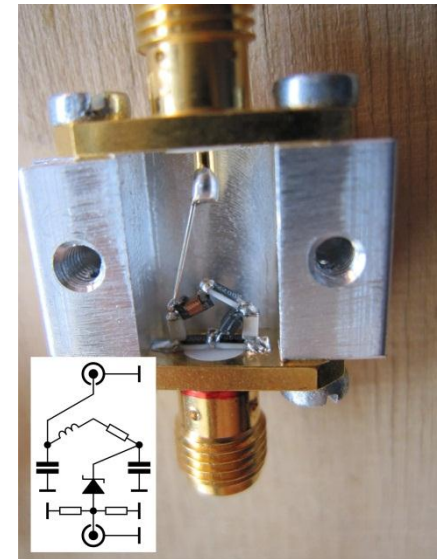
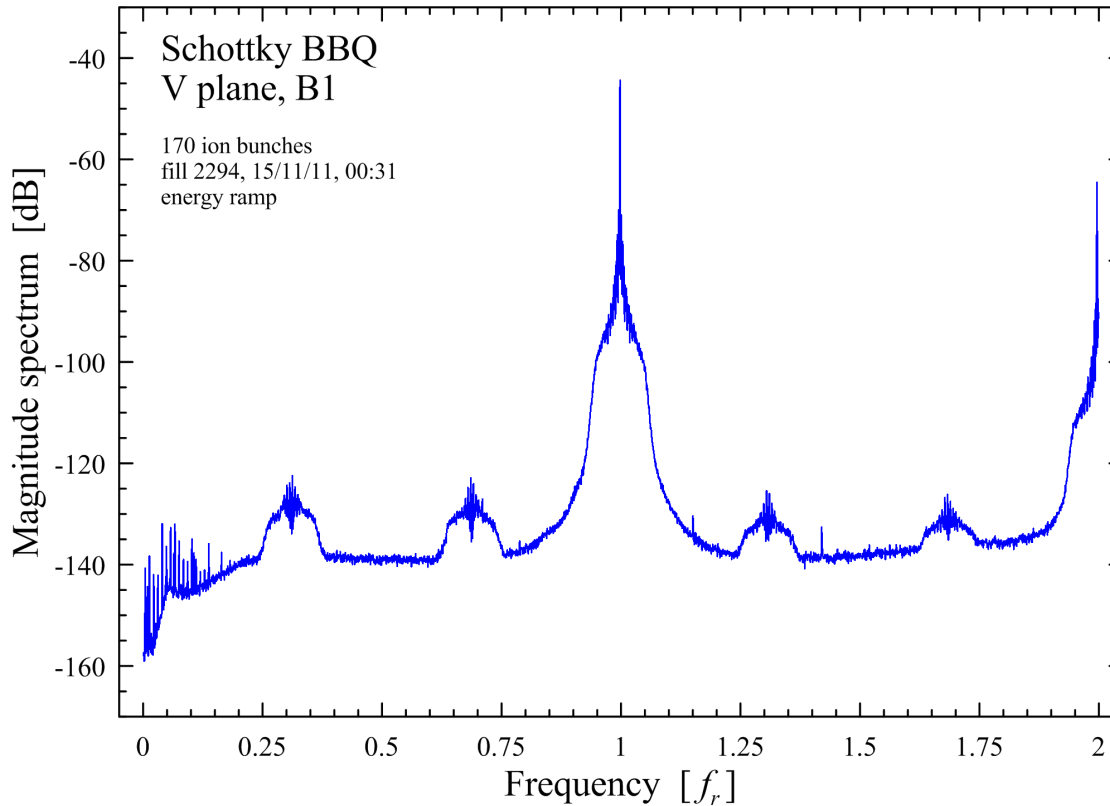
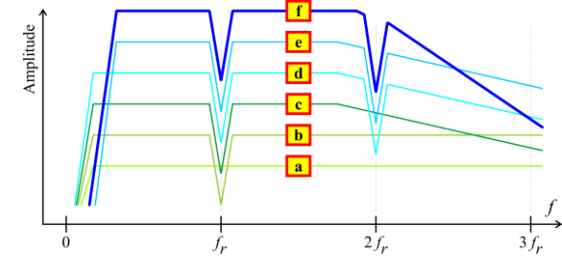
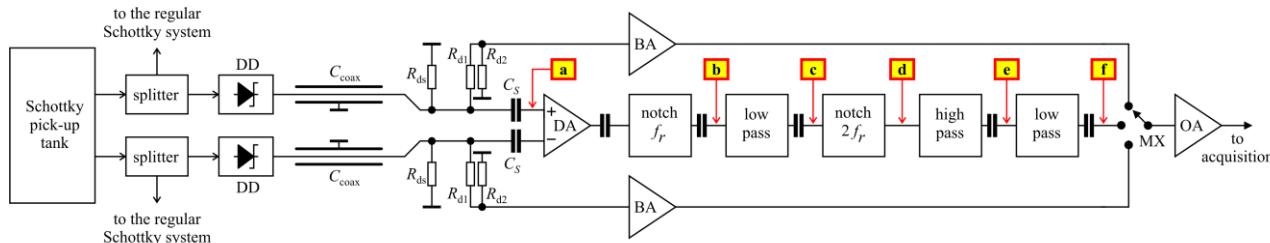

- BBQ system optimised for 4.8 GHz operation.
- A development system installed in 2011.

Detector diode	V_{\max} [V]	4.8 GHz		1 GHz	
		V_o [V]	S11 [dB]	V_o [V]	S11 [dB]
BAS283	70	0.723	-6.8	0.740	-20.8
HSMS286	4	1.486	-9.3	0.871	-27.5
2x HSMS286	8	1.031	-17.4	0.771	-31.4
HSMS282	15	1.642	-2.9	0.865	-18.4
HSMS286+280	70	1.662	-10.8	0.781	-23.0
2x HSMS280	140	0.749	-6.6	0.750	-21.0

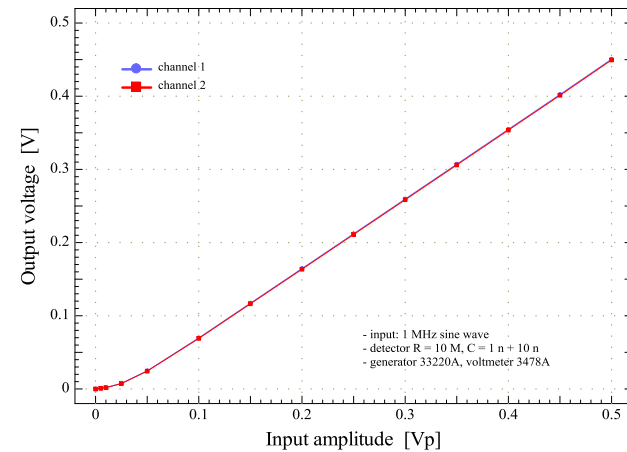
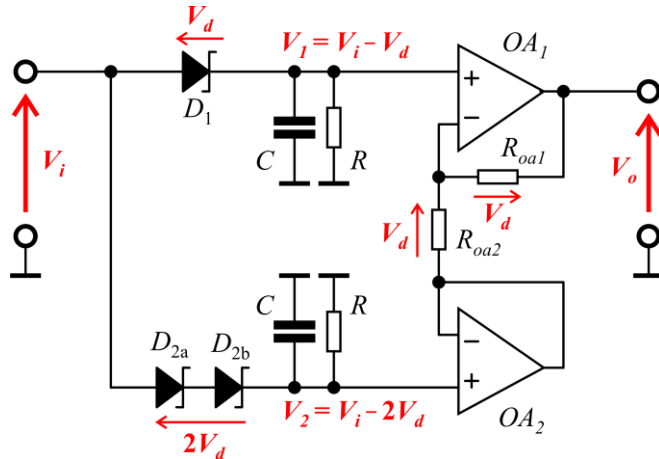
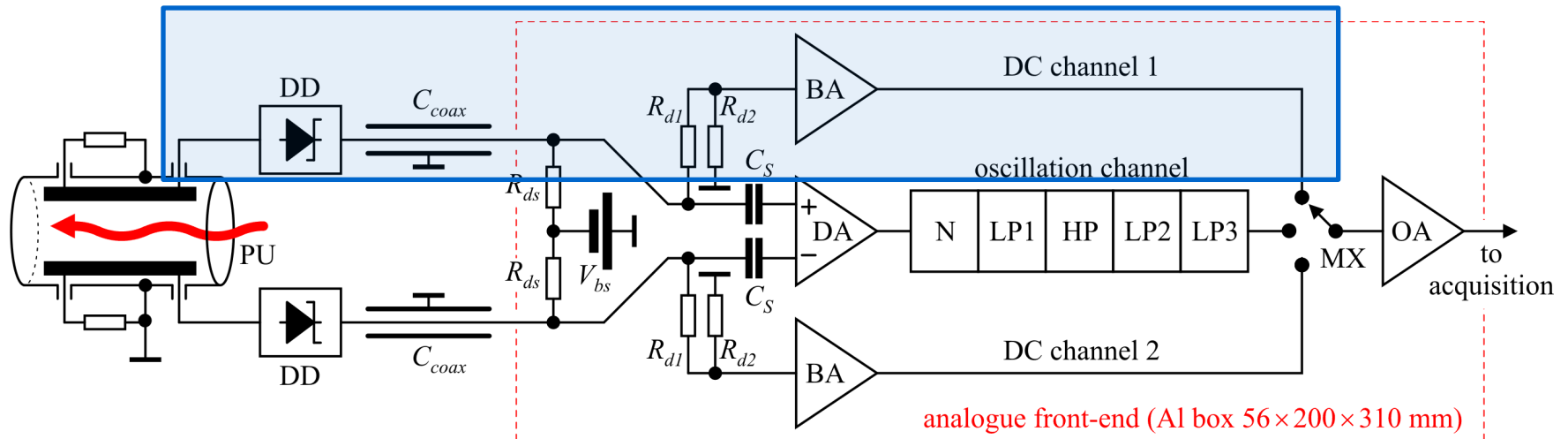

- Analogue front-end has dedicated channels to monitor detector DC voltages (testing purposes).
- DC signals can be measured with lab voltmeters (6 - 8 digit resolution possible).
- Simple diode detectors are nonlinear.
- A compensation scheme to achieve a linear characteristic.

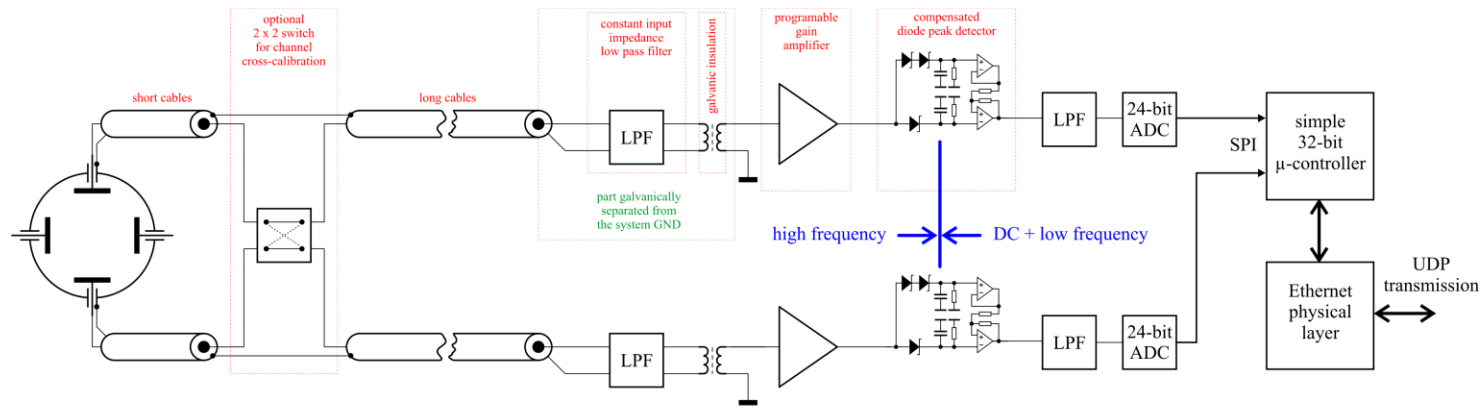

Diode ORbit (DOR) Measurement

2 channels shown for one pick-up plane, one 19" 1U unit accommodates 8 channels

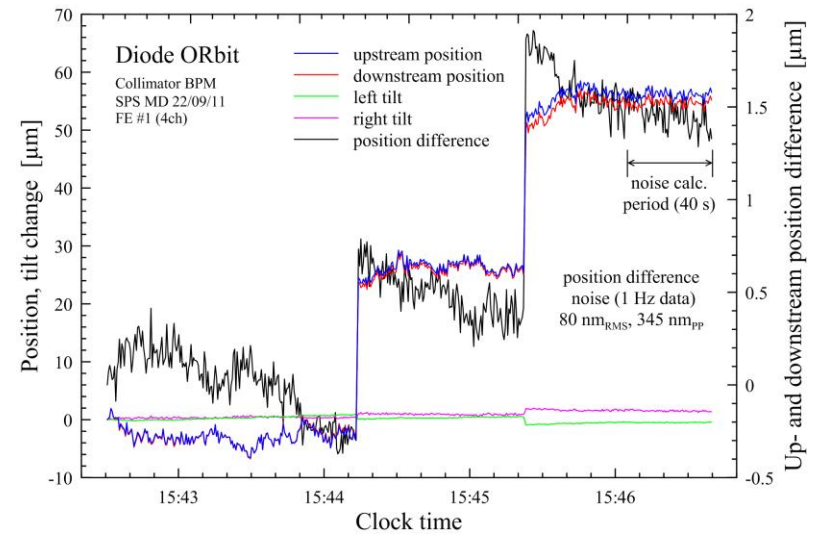
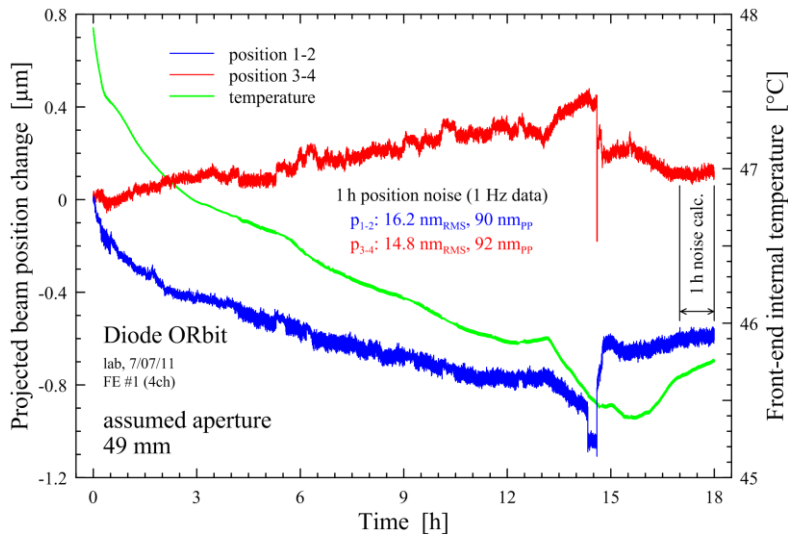

- Sub-micrometre resolution can be achieved with relatively simple hardware and signals from any position pick-up.
- To be used for the future LHC collimators with embedded BPMs.

- The key people (historical order):
 - Rhodri Jones: 3D conception, beam dynamics, beam measurements, continuous help throughout the whole development;
 - Peter Cameron: PLL tune measurement, 3D conception, beam dynamics, BBQ prototyping on RHIC, beam measurements;
 - Andrea Boccardi: FPGA programming, design and implementation of digital signal processing algorithms, acquisition system design, LabView test software, lab and beam measurements;
 - Ralph Steinhagen: TuneViewer author, design and implementation of data processing, data visualisation, tune peak detection algorithms, tune feed-back, design and implementation of chromaticity measurement, 3D development, beam dynamics, beam measurements and beam data analysis.

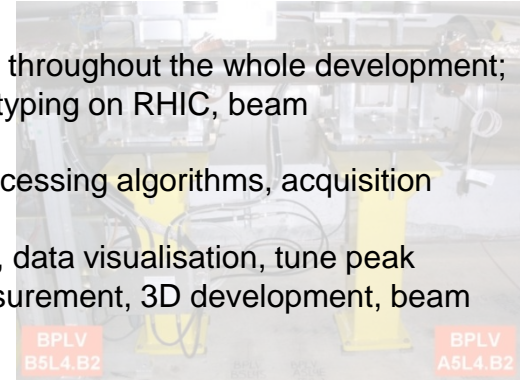
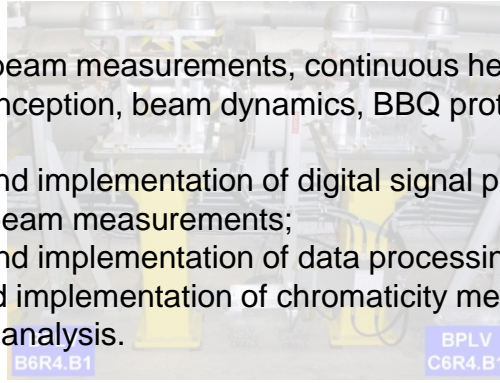

- Important contribution to the 3D development (historical order):
 - Jeroen Belleman: analogue signal processing, low noise JFET amplifier design, PS beam measurements, grounding and shielding issues;
 - Christian Boccard: design of the LHC stripline tune pick-ups;
 - Krzysztof Kasiński: LabView and FPGA programming;
 - Lars Jensen: real time software;
 - Peter Karlsson: SPS and LHC real time software;
 - Stephen Jackson: real time software.

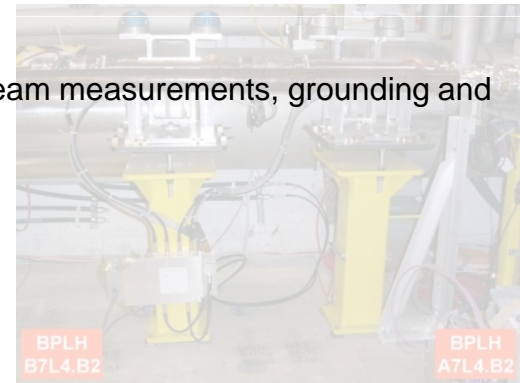
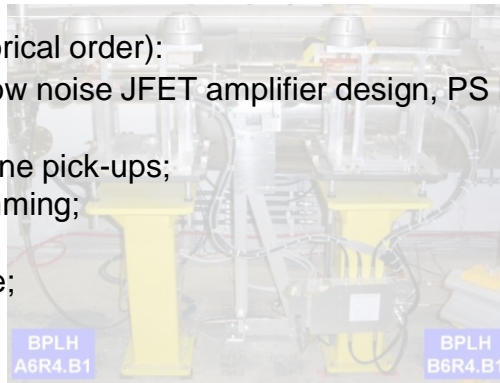

- Evaluation of the 3D technique outside CERN was done with the help of:
 - C.Y. Tan: 3D AFE testing at FNAL on Tevatron;
 - Rahul Singh: 3D AFE testing at GSI on SIS-18.

- The 3D development has been continuously supported by all members of the BE-BI-QP section as well as the CERN operators.

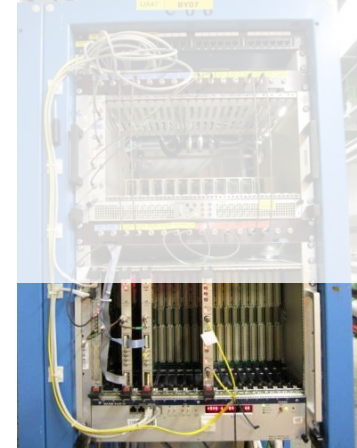
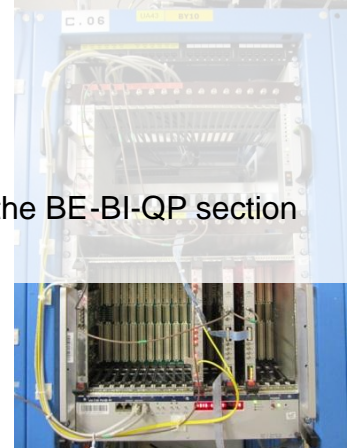
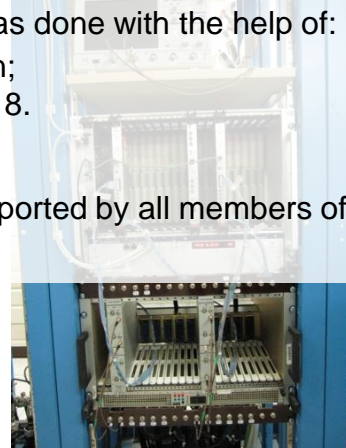
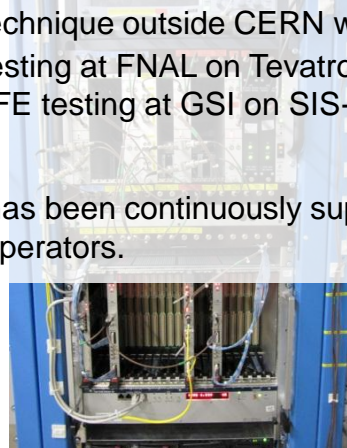

- Cold weather may stimulate fruitful discussions, which in turn can set the direction of a development.
- An error on a hand made schematic can make a breakthrough in a development.
- Good old ideas should be reviewed to make sure that they cannot be further improved with the recent technology advancement.
- Even with the excellent ADCs that we have today good analogue processing may pay off.
- Diode-based tune measurement works well already on quite a few machines.
- Diode detectors most likely can be used for other applications.
- Marek got a reputation to do everything with diodes:
„When Marek wants to open a bottle of beer, the first tool he thinks about is a diode.”
- The BIW Faraday Cup paper contains further details and references.
- A few pieces of beam sound can be found at: www.cern.ch/gasior/pro/BBQ/index.html

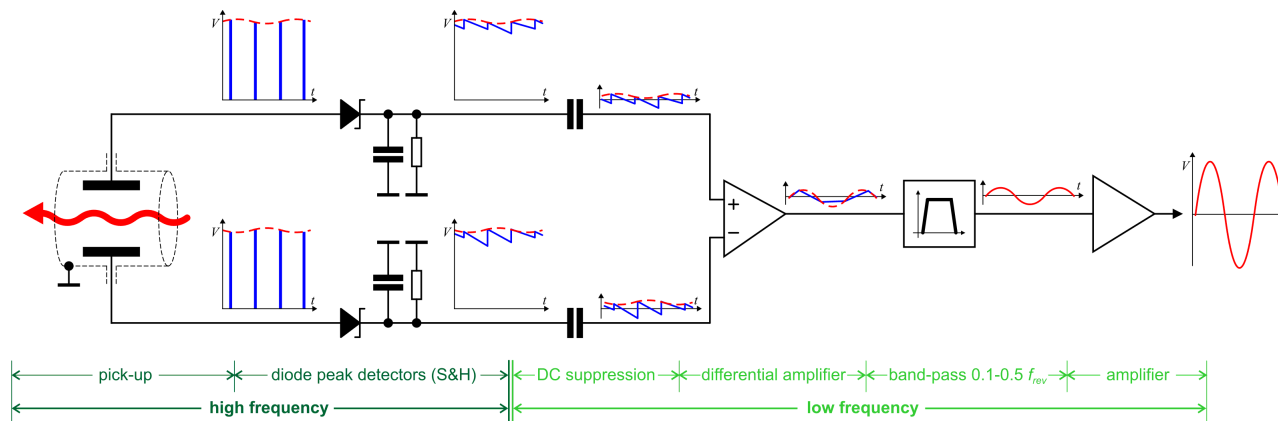
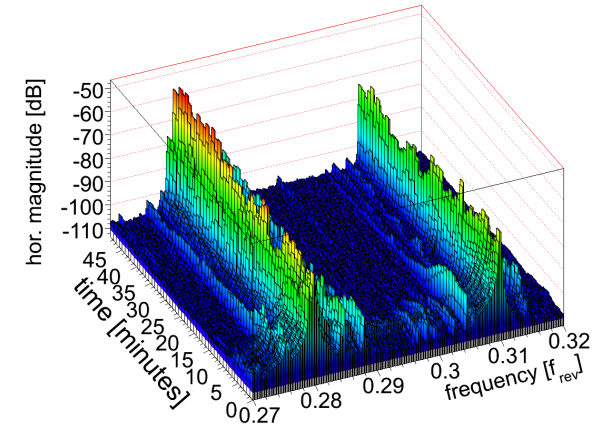

Diode tune systems

Machine	Lab	max f_{rev} [kHz]
LHC	CERN	11
SPS	CERN	43
PS	CERN	477
PSB	CERN	1800
LEIR	CERN	1440
RHIC	BNL	78
Tevatron	Fermilab	48
SIS18	GSI	1400
CNAO	CNAO	2800
CesrTA	Cornell	390

Spare slides

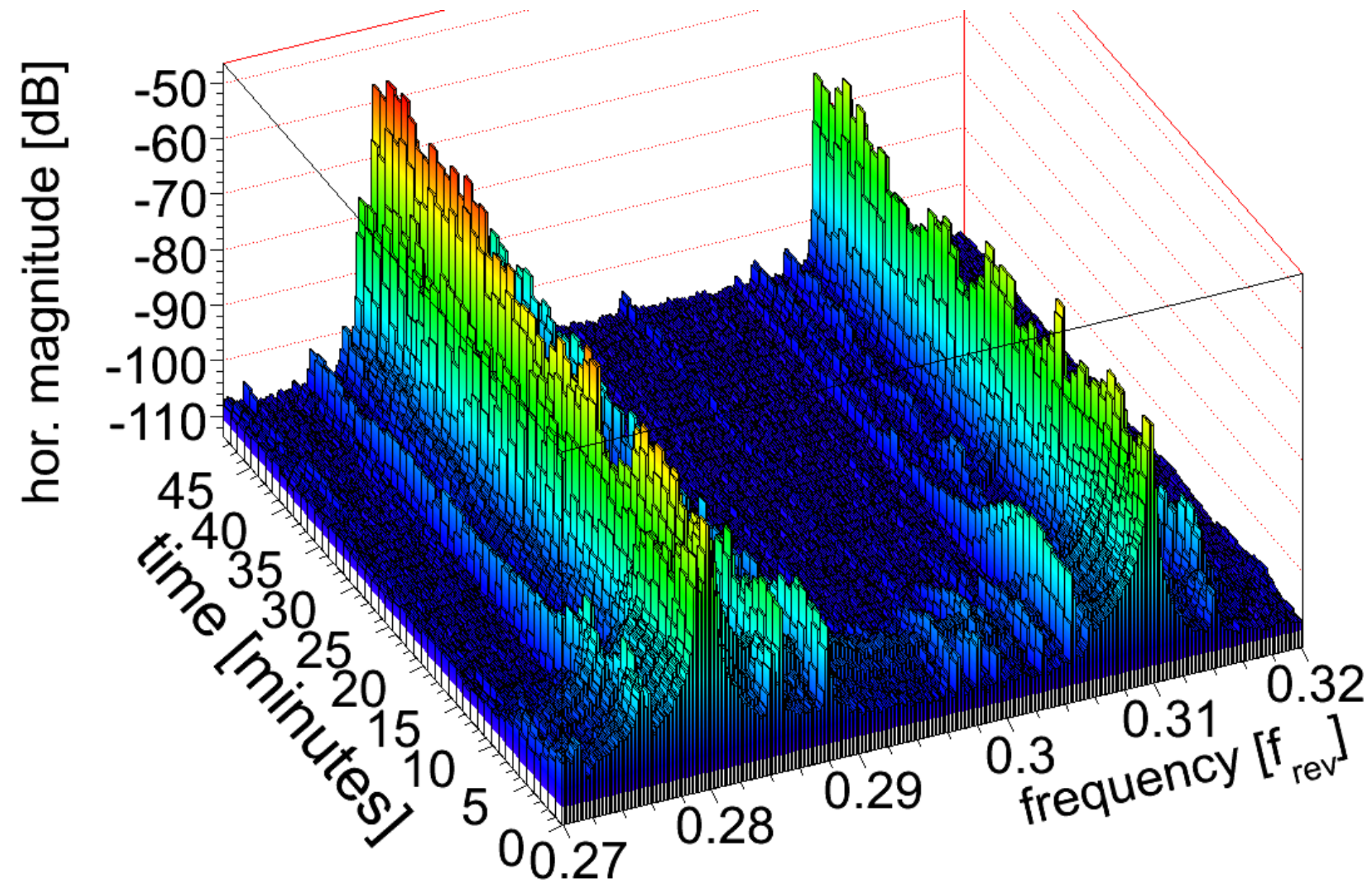

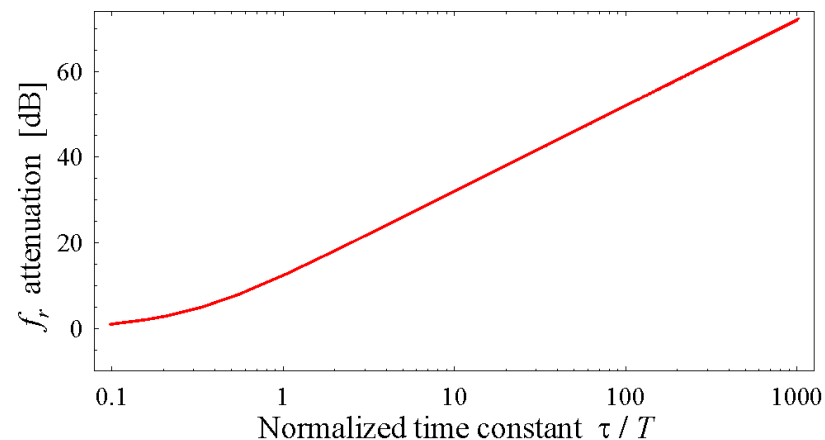
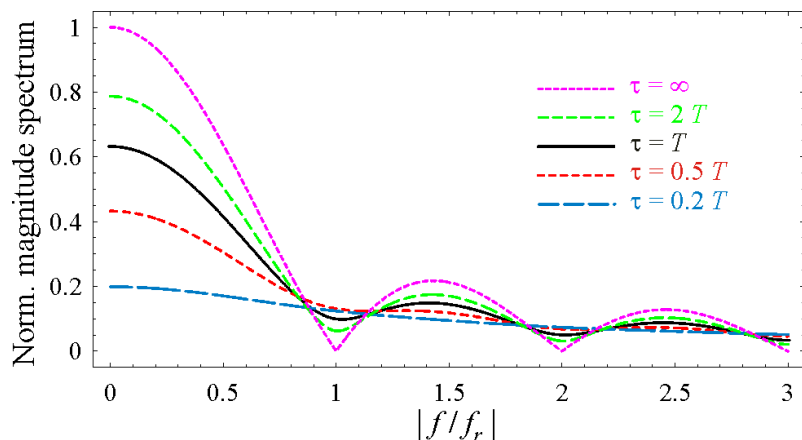
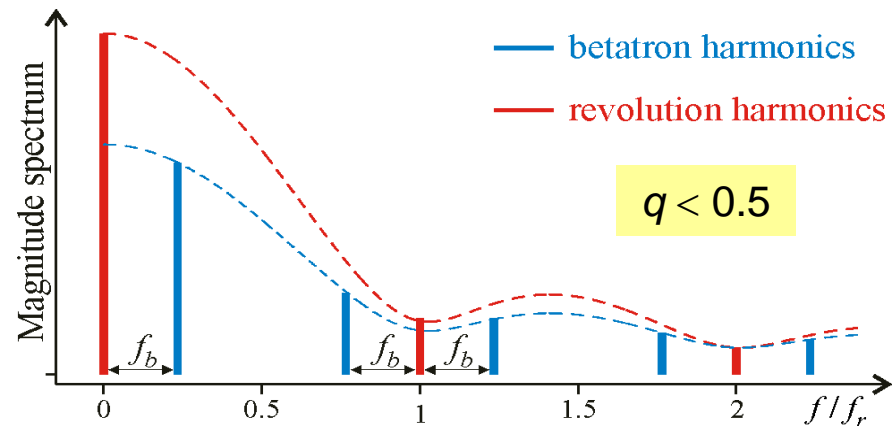
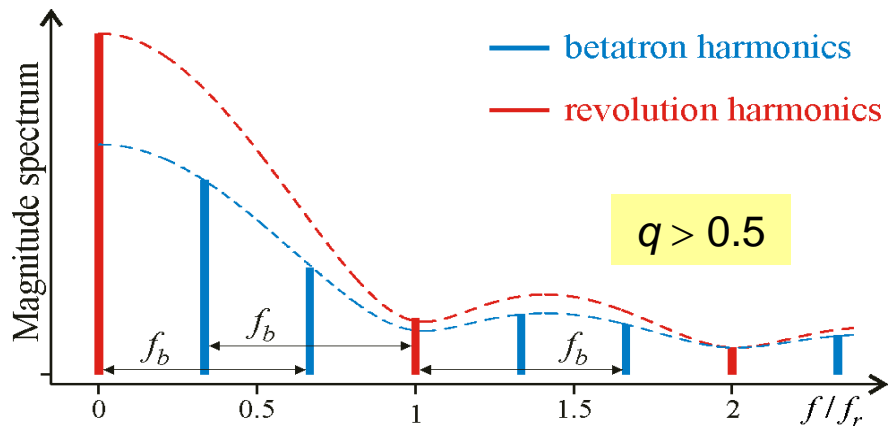

$$S_f(f) = \tau \left| \frac{1 - \exp\left(-j2\pi fT - \frac{T}{\tau}\right)}{1 + j2\pi fT} \right|$$

$$\xi = \frac{S_f\left(\frac{f_r}{2}\right)}{S_f(f_r)} = \sqrt{4 - \frac{3T^2}{T^2 + \pi^2 \tau^2} \coth\left(\frac{T}{2\tau}\right)}$$

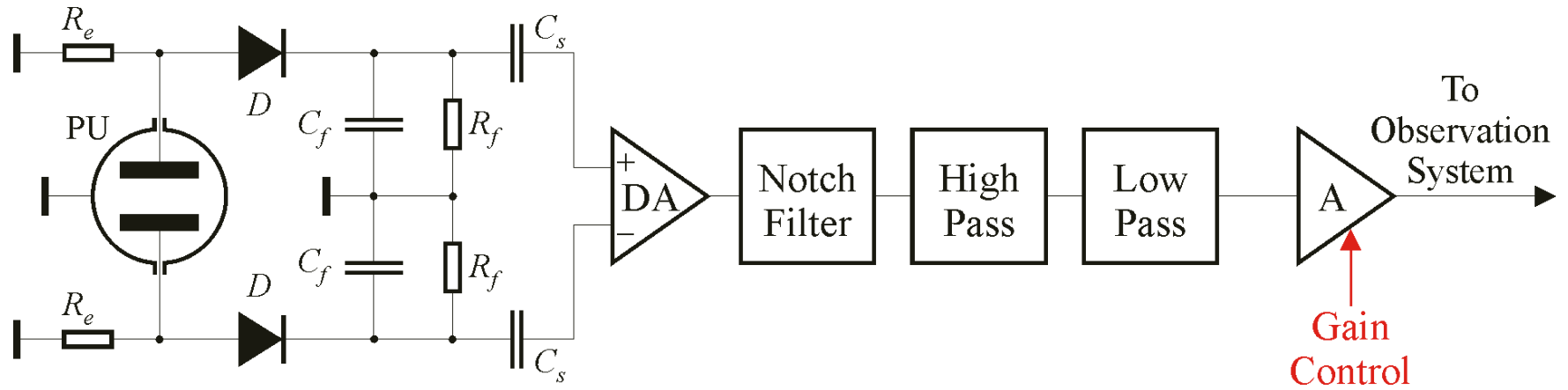

Detector box (for one PU electrode)



Analogue front-end box (2 channels)

LHC, SPS

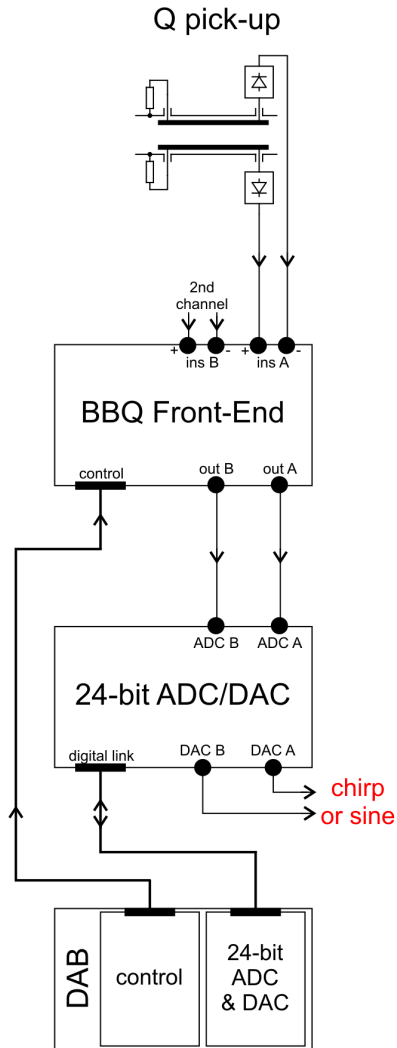

LEIR, PSB, PS, AD: ADCs + DACs only

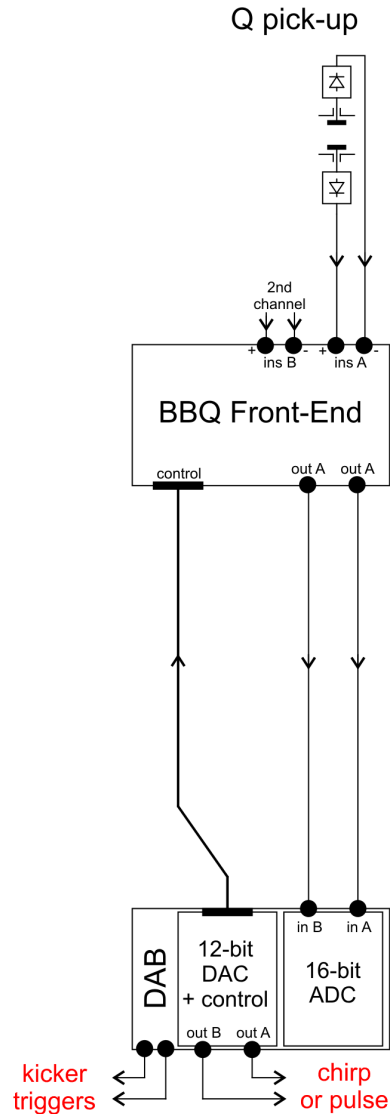

Machine	Front-End	Acquisition
LHC	"constant f_{rev} type"	24 bits (up to 100 kHz)
SPS	"constant f_{rev} type"	24 bits
PS	"constant f_{rev} type"	16 bits (up to 40 MHz)
LEIR	"varying f_{rev} type"	16 bits
PSB	"varying f_{rev} type"	16 bits

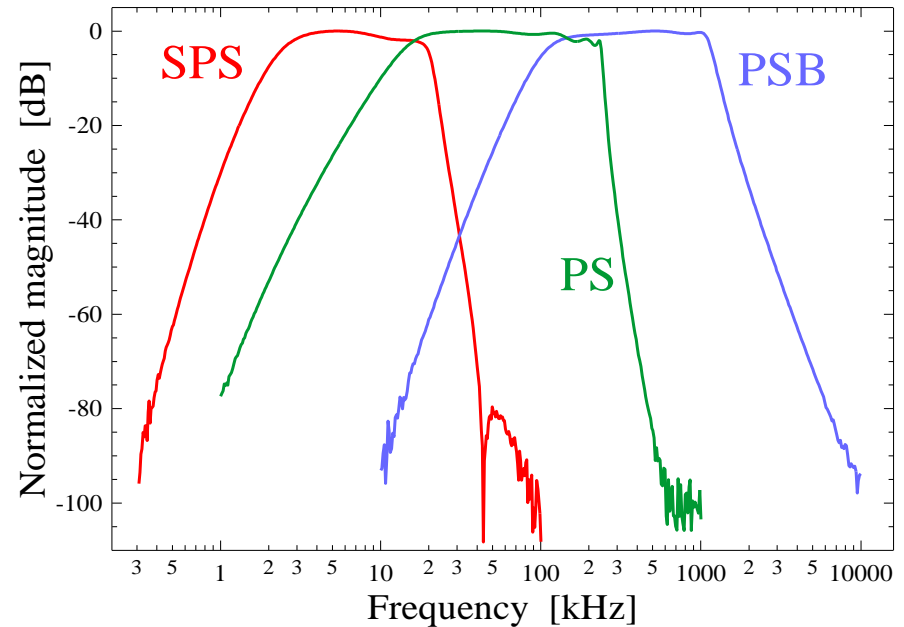

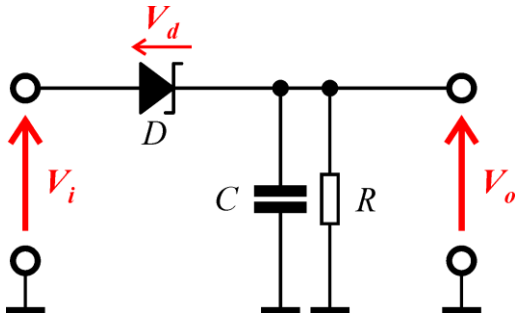

- The discharge resistor R can be used to change the regime in which the detector operates.
- Number of bunches have influence on the operation mode. An average detector with single bunch can be a peak detector with the full machine.

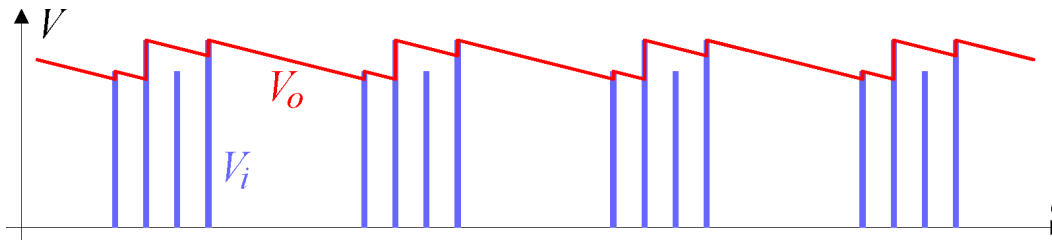

Input (V_i) and output (V_o) voltages of a peak detector with an ideal diode

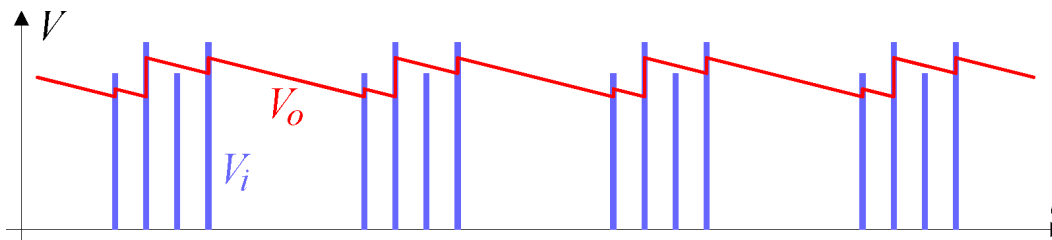

Input (V_i) and output (V_o) voltages of a peak detector with a real diode

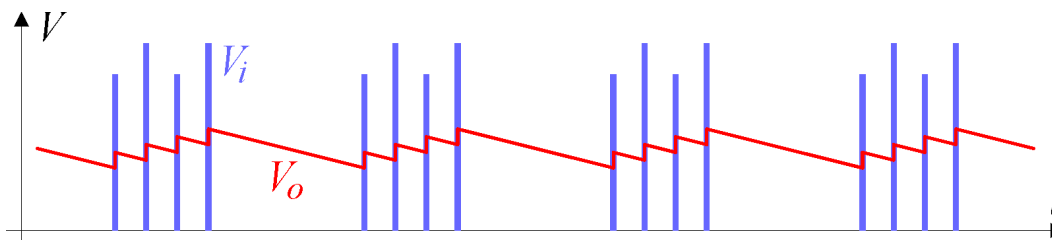

Input (V_i) and output (V_o) voltages of an average-value detector

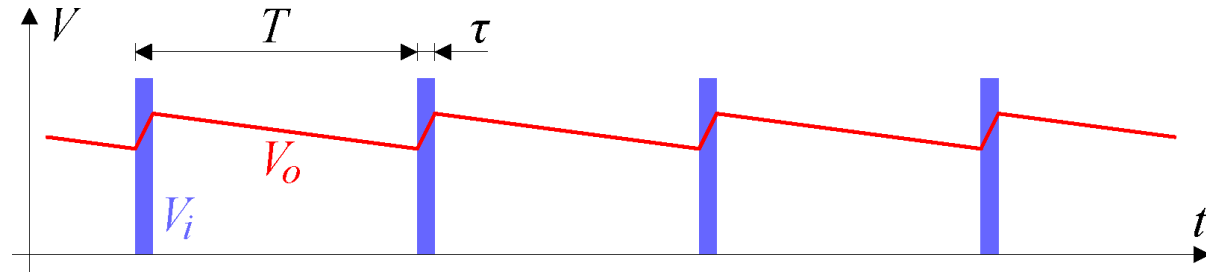
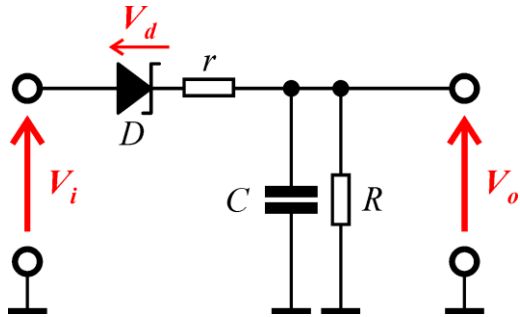

Charge balance equation for the following assumptions:

- a simple diode model with a **constant** forward voltage V_d and a **constant** series resistance r .
- constant charging and discharging current, i.e. output voltage changes are small w.r.t. the input voltage.

A numerical example: LHC, one bunch.

For LHC $\tau \approx 1$ ns and $T \approx 89$ μ s, so for $V_o \approx V_i$

one requires $R/r > T/\tau$.

Therefore, for $r \approx 100$ Ω , $R > 8.9$ M Ω .

- For large T to τ ratios peak detectors require large R values and a high input impedance amplifier, typically a JFET-input operational amplifier.
- The slowest capacitor discharge is limited by the reverse leakage current of the diode (in the order of 100 nA for RF Schottky diodes).

$$\frac{V_o}{R} T = \frac{V_i - V_o - V_d}{r} \tau$$



$$\frac{V_o}{V_i - V_d} = \frac{1}{1 + \frac{r}{R} \cdot \frac{T}{\tau}}$$



- $V_i \gg V_d$
- n bunches

$$\frac{V_o}{V_i} = \frac{1}{1 + \frac{r}{R} \cdot \frac{T}{n\tau}}$$