

Vector Control Algorithm for Efficient Fan-out RF Power Distribution



Yoon W. Kang
SNS/ORNL

Fifth CW and High Average Power RF Workshop
March 25-28, 2008

Motivation

- **Fan-out RF distribution with one higher power amplifier feeding multiple cavities may save construction/installation cost significantly especially in high power SRF linear accelerator projects**
- **If a fixed power splitter is used with Vector Modulators in the fan-out system, power overhead is required for proper amplitude control**
 - **Each cavity load needs one vector modulator that consists of two phase shifters and two hybrids**
 - **The vector modulator dissipates the power difference between the input and the output**
- **It is desirable to maximize the RF power to beam efficiency for further savings in operation**
 - **Almost no power overhead is required - deliver only the beam power to the cavities with right RF voltages**
- **An algorithm for fan-out RF distribution and control as a whole system is presented**

Use of Vector Modulator

$$\frac{A_{out}}{A_{in}} = \cos\left(\frac{\phi_1 - \phi_2}{2}\right)$$

$$\phi_{out} = -\frac{\phi_1 + \phi_2}{2}$$

- This gives the output amplitude and phase of the vector modulator in terms of the phase shift of each of the two phase shifters.
- For a fixed input power, unused power P_L is lost

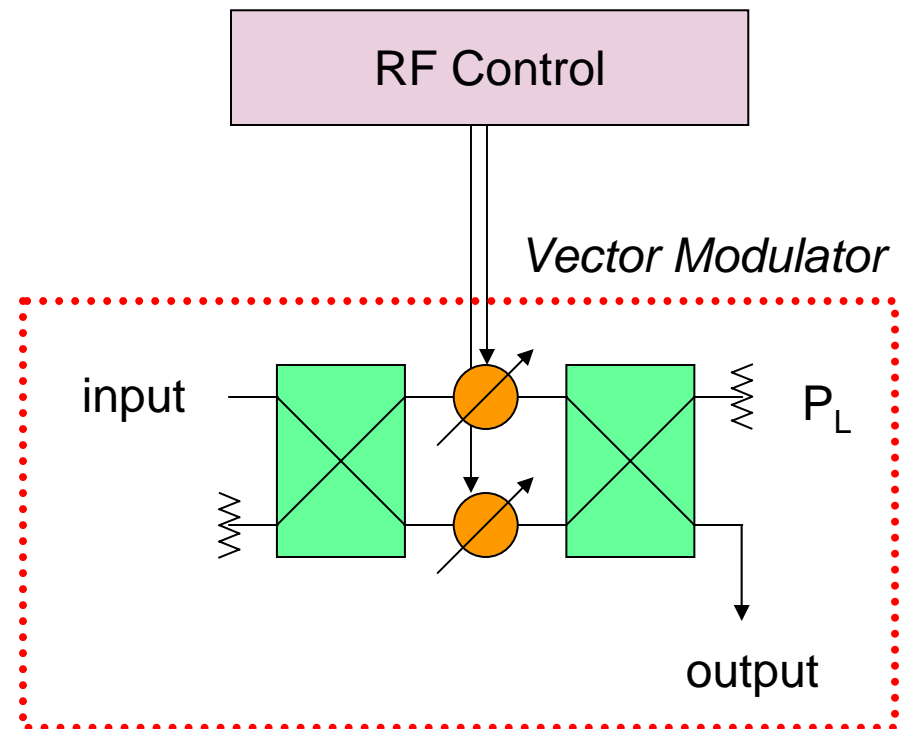

Comparison of RF Power Distribution Systems

- One klystron/one cavity

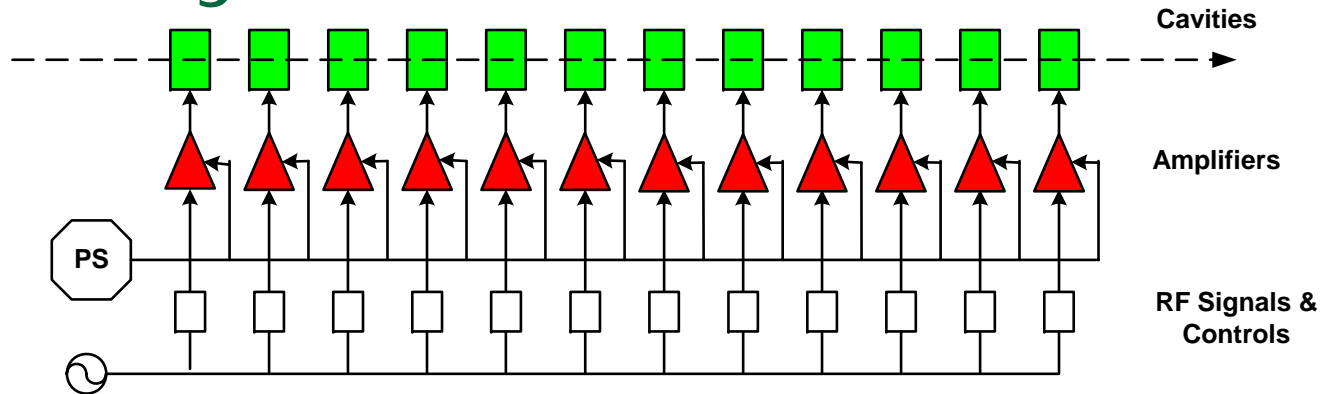

- Fan-out one klystron with Vector Modulators – power overhead requirement

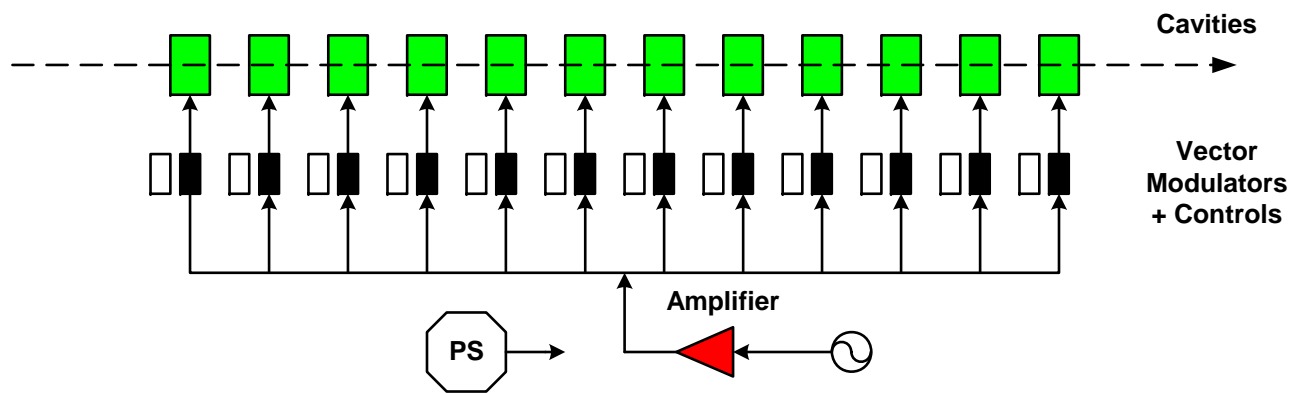

- Fan-out one klystron with no overhead power

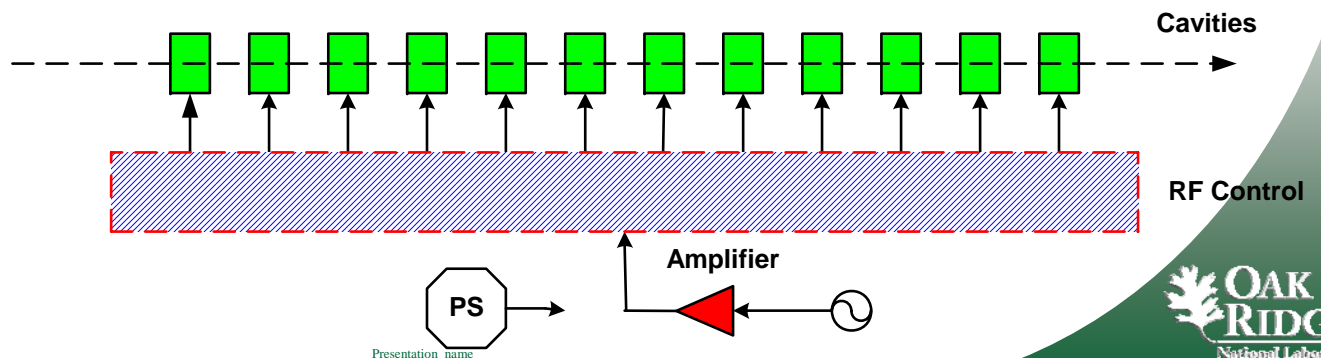

Fan-out RF Distribution

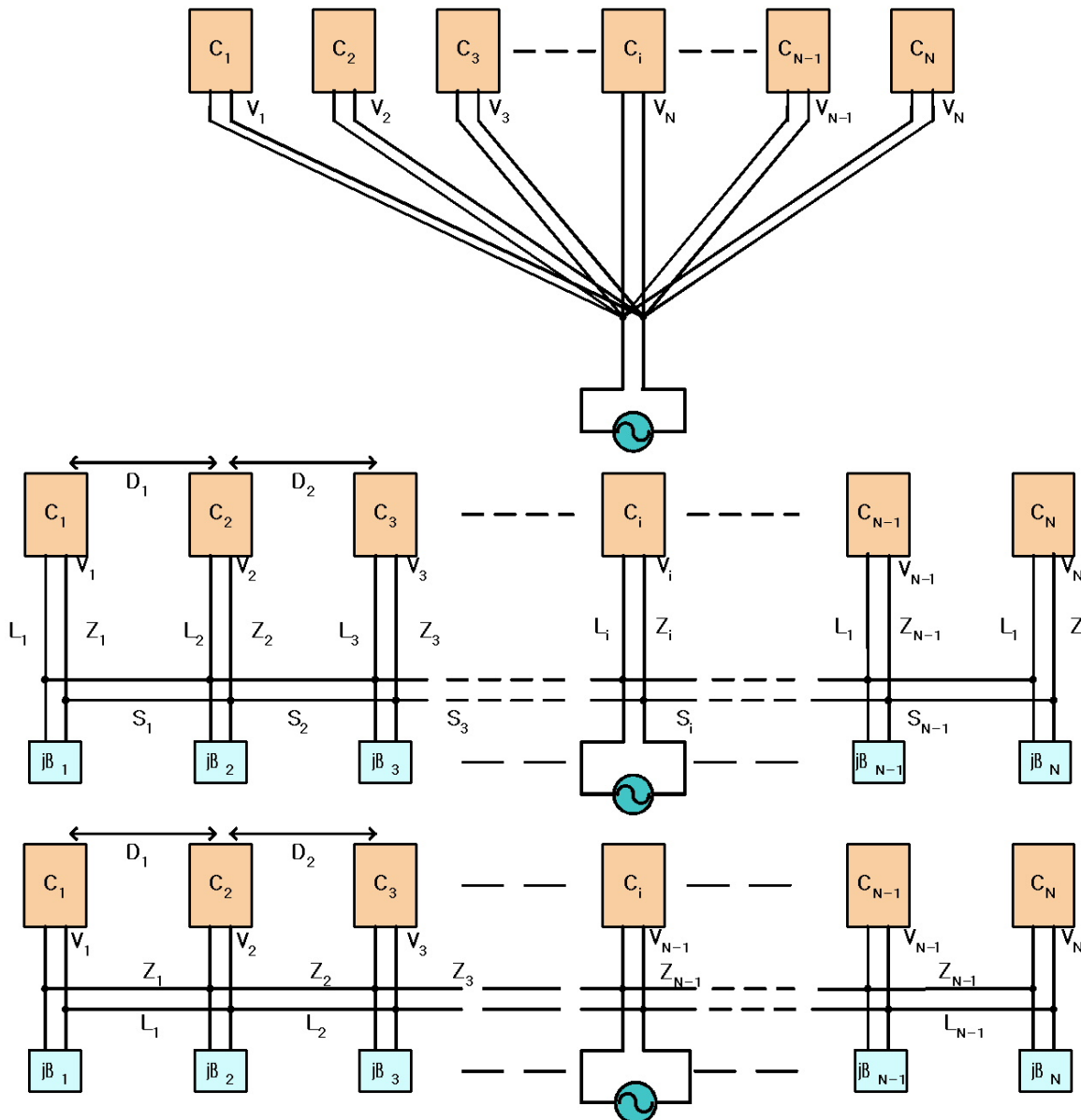

1. Distributing RF power to N -loads through a transmission line network – a parallel connection

2. If the spacing $S_i = M(\lambda/2)$, L_s , Z_s , and B_s can supply the specified voltages to the load – a series connection

3. A variation to the above case

Fan-out System Control using Transmission-line Sections and Reactive Loads

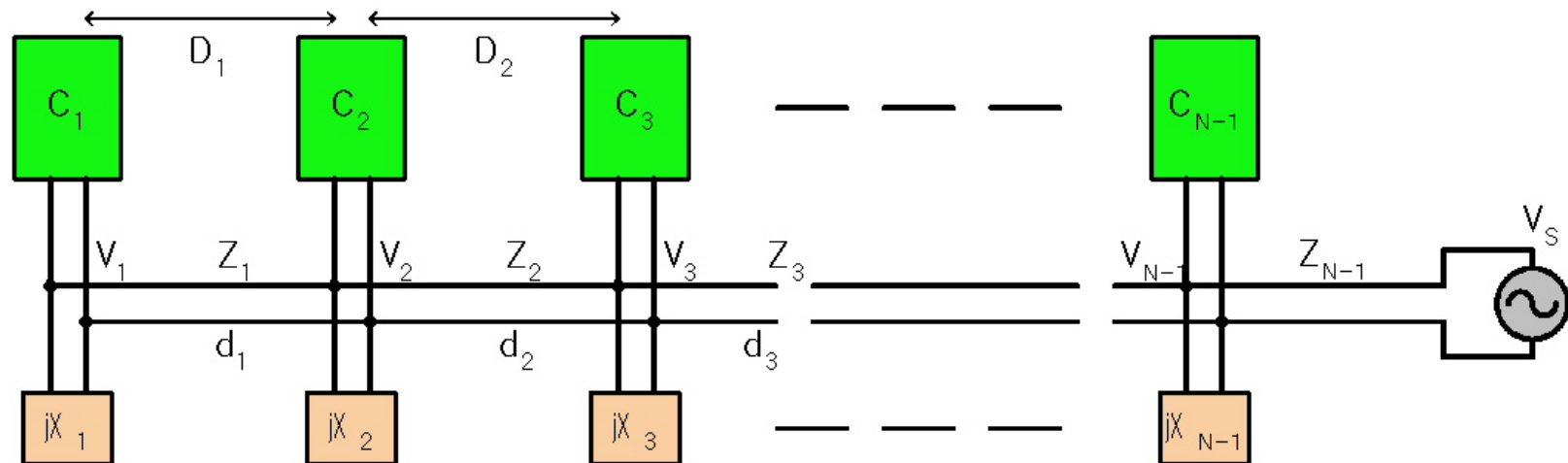

- D_i = physical spacing between cavities
 - d_i = length of transmission section between cavities
 - V_i = voltage delivered to the cavity input
 - Z_i = transmission-line characteristic impedance
 - X_i = reactive load
- **A set of specified voltages $[V_i]$ can be supplied to the load cavities by adjusting the transmission-line impedances, lengths, and reactive loadings**
 - **This can be seen as a narrow-band multi-port impedance matching network**

Network Parameters



- A two-port network is used as a building block of a multi-port network synthesis
- Various configurations are realizable: series fed, parallel fed, mixed, etc.
 - Network with parallel connections can be synthesized and analyzed by using short-circuit admittance matrices [Z]
 - Network with series connections can be synthesized and analyzed by using open-circuit impedance matrices [Y]
- Short-circuit admittance parameters [Y] are useful for network consists of elements in parallel connections
- Using [Y], the voltages and currents of a two port network are related as

$$\begin{bmatrix} I_1 \\ I_2 \end{bmatrix} = \begin{bmatrix} y_i & y_r \\ y_f & y_o \end{bmatrix} \begin{bmatrix} V_1 \\ V_2 \end{bmatrix}$$

where

$$y_i = y_{11} = \left. \frac{I_1}{V_1} \right|_{(V_2=0)} \quad y_r = y_{12} = \left. \frac{I_1}{V_2} \right|_{(V_1=0)} \quad y_f = y_{21} = \left. \frac{I_2}{V_1} \right|_{(V_2=0)} \quad y_o = y_{22} = \left. \frac{I_2}{V_2} \right|_{(V_1=0)}$$

System Equation (I)

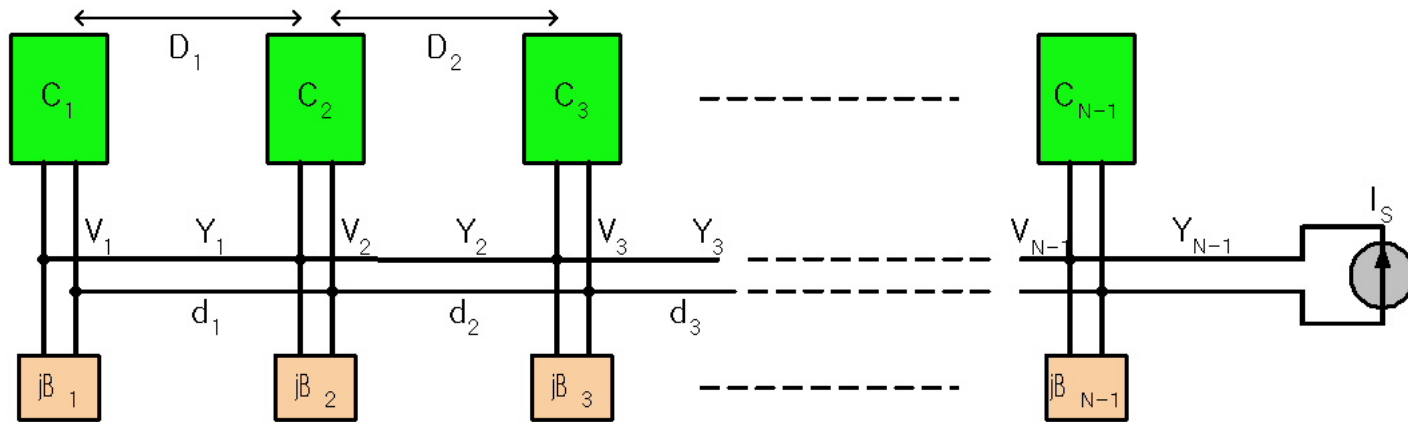

Consider an array of N -cavity loads connected to a transmission-line network. Let $[V^P]$ be the port voltage vector of a set of specific cavity excitations for an optimum operation.

$$[V^P]^t = [V_1^P \quad V_2^P \quad V_3^P \quad \dots \quad V_{N-1}^P]$$

The relation between the terminal currents $[I^S]$ and the terminal voltages $[V^P]$ is

$$[I^S] = [Y^S][V^P]$$

where the short-circuit terminal admittance matrix of the whole system

$$[Y^S] = [Y^P] + [Y^T] + [Y^L] \quad [1]$$

$[Y^P]$ = port admittance matrix for the cavities,

$[Y^T]$ = short circuit admittance matrix of the transmission line network,

and $[Y^L]$ = load admittance matrix.

System Equation (II)

The port admittance matrix only with the loads with no couplings between the cavities

$$[Y^P] = \begin{pmatrix} Y_{in,1} & 0 & 0 & \cdots & 0 \\ 0 & Y_{in,2} & 0 & \cdots & 0 \\ 0 & 0 & Y_{in,3} & \cdots & 0 \\ \vdots & \vdots & \vdots & \ddots & \vdots \\ 0 & 0 & 0 & \cdots & Y_{in,N} \end{pmatrix}$$

If a cavity is mismatched, the port admittance matrix at the input of a cavity is found as:

$$Y_{in} = Y_o \frac{Y_L \cos \beta d^c + jY_o \sin \beta d^c}{Y_o \cos \beta d^c + jY_L \sin \beta d^c}$$

where Y_o and d^c are the characteristic impedance and the length of the transmission line connects the cavity to the network, respectively, Y_L is the cavity load impedance, and β is the phase constant. The load is related to the reflection coefficient

$$Z_L = Z_o \frac{1 + \Gamma(z)}{1 - \Gamma(z)}$$

The transmission line admittance matrix

$$[Y^T] = \begin{pmatrix} -jY_1 \cot \beta d_1 & jY_1 \csc \beta d_1 & 0 & \cdots & 0 \\ jY_1 \csc \beta d_1 & -j(Y_1 \cot \beta d_1 - Y_2 \cot \beta d_2) & jY_2 \csc \beta d_2 & \cdots & 0 \\ 0 & jY_2 \csc \beta d_2 & -j(Y_2 \cot \beta d_2 - Y_3 \cot \beta d_3) & \cdots & 0 \\ \vdots & \vdots & \vdots & \ddots & \vdots \\ 0 & 0 & 0 & \cdots & -jY_{N-1} \cot \beta d_{N-1} \end{pmatrix}$$

System Equation (III)

The reactive load admittance matrix

$$[Y^L] = \begin{pmatrix} jB_1 & 0 & \cdots & 0 \\ 0 & jB_2 & \cdots & 0 \\ \vdots & \vdots & \ddots & \vdots \\ 0 & 0 & \cdots & jB_N \end{pmatrix}$$

If the n -th terminal is used for feeding, only $I_n = 1$ in the current matrix

$$[I^S]^t = [0 \ 0 \ 0 \ \cdots \ 1 \ \cdots \ 0]$$

The input impedance is found by selecting the element Z_{ii} in impedance matrix $[Z^S]$

$$[Z^S] = [Y^S]^{-1}$$

From $[Y^S] = [Y^P] + [Y^T] + [Y^L]$ the m -th element of the current vector is found as

$$I^S \delta_{nm} = y_m^{in} V_m^P - j \{ Y_{m-1}^T V_{m-1}^P \csc(\beta d_{m-1}) + Y_{m-1}^T V_m^P \cot(\beta d_{m-1}) + Y_m^T V_m^P \cot(\beta d_m) + Y_m^T V_{m+1}^P \csc(\beta d_m) \} + j V_m^T B_m$$

(for $m=1, 2, \dots, N$) where n is the feed port index.

The above equations can be solved for a specified load voltages $[V^P]$ if any one out of the three parameters is given: *transmission-line characteristic admittances, transmission-line lengths, and reactive loads*. If a standard transmission line impedance Y^S is used, the lengths d_m (d_{m-1}), and reactive loads B_m can be found. Y_{m-1}^S (Y_m^S) and, d_{m-1} (d_m) are given so that the d_m (d_{m-1}), and reactive loads B_m are found.

Generalized RF Distribution

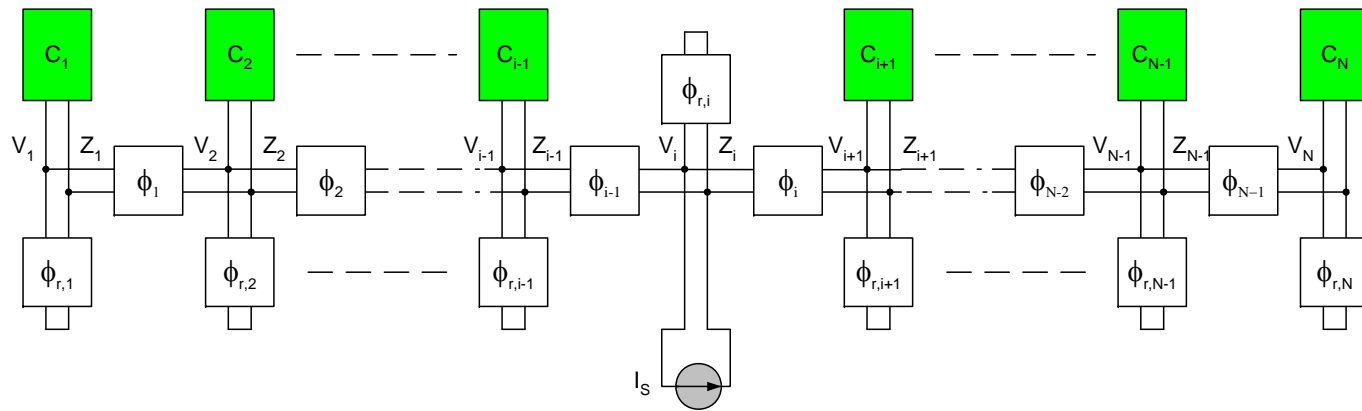

The lengths of the transmission line sections and the reactive loads are related to the phase shifts as

$$\phi_n^T = \beta d_n \quad \phi_n^L = \cot^{-1}(-B_n/Y_o)$$

The transmission-line lengths and reactive loads can be realized by using high power phase shifters

If the loads are mismatched loads, the voltage standing wave in the transmission line section between the cavity and the input port is

$$V(z) = V_o^+(z)e^{-j\beta z} \{1 + \Gamma(z)\}$$

where voltage reflection coefficient $\Gamma(z)$

$$\Gamma(z) = \frac{Z(z) - Z_o}{Z(z) + Z_o} = \frac{V_m^-}{V_m^+} e^{2\gamma z}$$

The voltage vector can be defined for no power ($V_i = 0$), forward power, or standing wave with the reflection coefficient $\Gamma(z)$

Input Matching

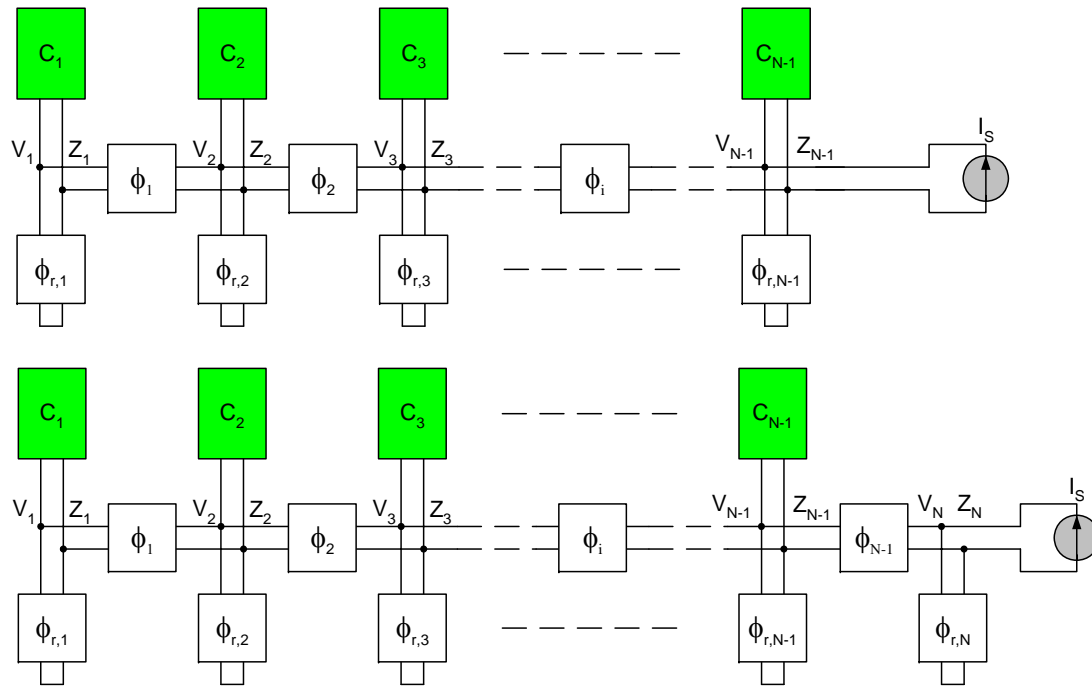

- The voltage distribution is done, but the input of the network is not impedance matched to the source impedance
- The input of the network can be impedance matched to a source with a specific source impedance by adding one more port

The total power delivered to the loads is the sum of real power at the loads and must be identical to the output power of the klystron

$$P = [V^P]^T [Y^P] [V^P]^* = \sum_{i=1}^N |V_i^P|^2 Y_i^P = |V_f^P|^2 / Y_f^P$$

The feed terminal voltage is found from the above expression for a desired input impedance. The voltage vectors are reconstructed to include the input that has an impedance specified. This constraints the input to be matched to the generator output

$$[V^P]^T = [V_1^P \quad V_2^P \quad V_3^P \quad \dots \quad V_f^P \quad \dots \quad V_N^P]$$

Simplified Fan-out System

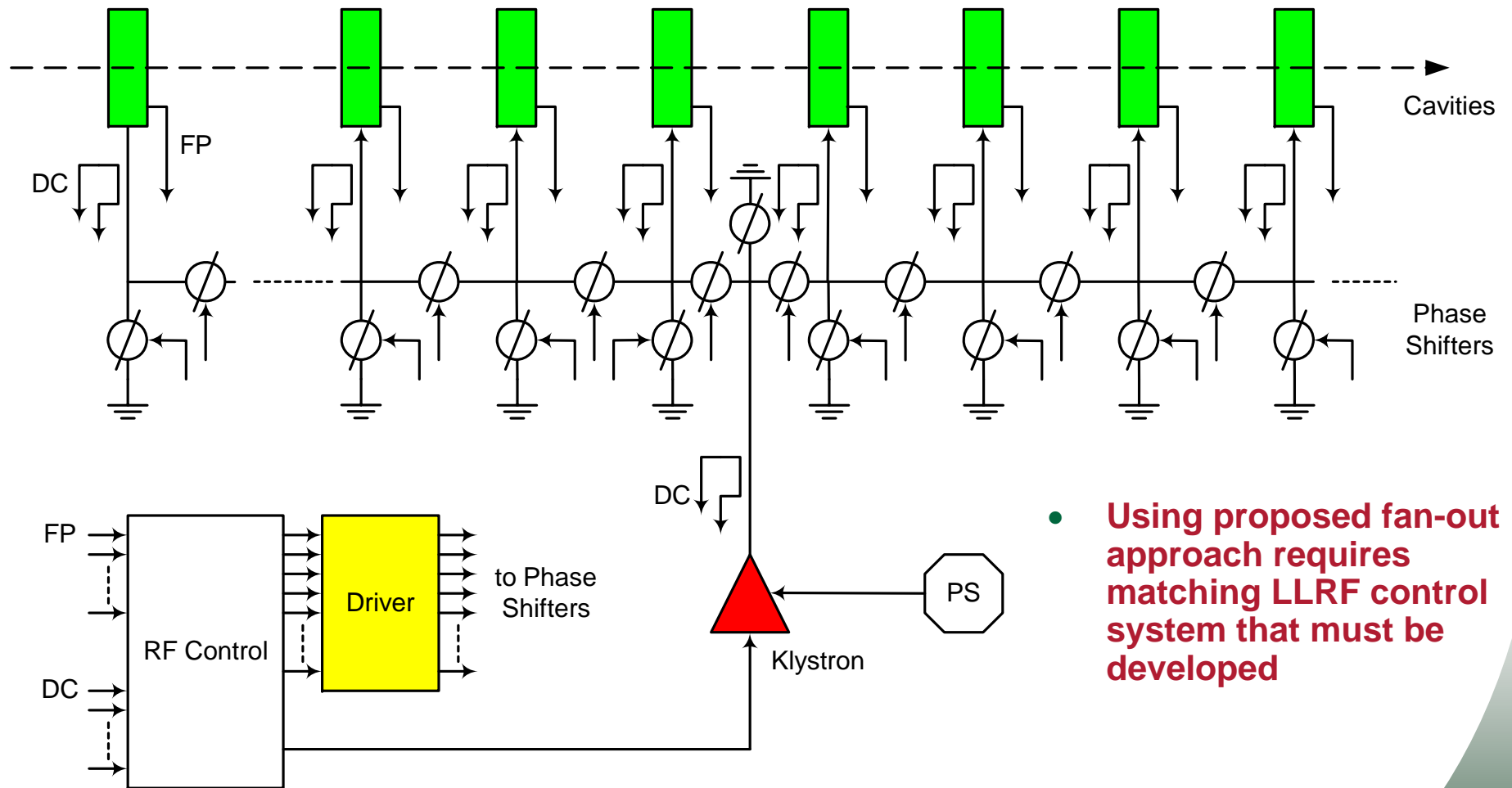

- Using proposed fan-out approach requires matching LLRF control system that must be developed

Procedure Summary and Consideration

- Directional coupler at each cavity input measures cavity coupling (and load impedance)
- A set of voltage vectors is defined for the required cavity RF voltages (amplitudes and phases)
- The system equation is solved for the transmission line phase delays and the reactive loads at the ports
- Phase shifters are tuned to the computed values
- The resultant voltages are read back and adjusted with FF and FB
- The above steps can be repeated

- For a system with N - load cavities, followings are need to deliver the required voltages at the cavity coupler inputs with completely matched klystron amplifier output
 - N phase shifters between the terminals (transmission-line sections)
 - $N+1$ phase shifters at all terminals (reactive loads)
- Fast high power phase shifters are needed
- Amplifier output control

Example

12 cavities @ $f = 805$ MHz,
cavities are critically coupled

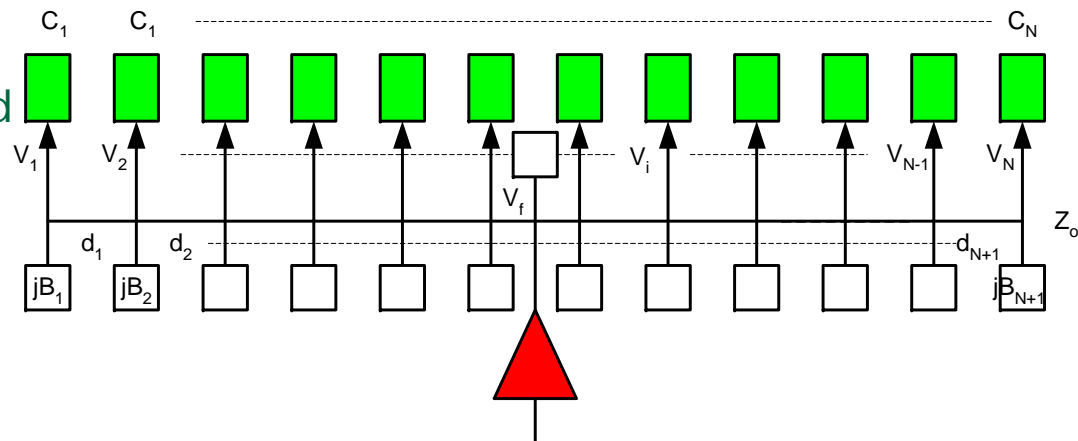

| Cavity | Distance (m) | Voltage (V) | Zo (Ω) | d_i (m) | jB_i (Ω) |
|--------|--------------|----------------------|-----------------|-----------|---------------------|
| 1 | 1.50 | 1.0000 $/0^\circ$ | 50.0000 | 1.8742 | - 0.0056i |
| 2 | 1.50 | 1.0500 $/10^\circ$ | 50.0000 | 1.8690 | - 0.0026i |
| 3 | 1.50 | 1.1000 $/20^\circ$ | 50.0000 | 1.8673 | + 0.0020i |
| 4 | 1.50 | 1.1500 $/30^\circ$ | 50.0000 | 1.8664 | + 0.0056i |
| 5 | 1.50 | 1.2000 $/40^\circ$ | 50.0000 | 1.8659 | + 0.0088i |
| 6 | 1.50 | 1.2500 $/50^\circ$ | 50.0000 | 1.8330 | + 0.0715i |
| 7 | | (3.9083 $/0^\circ$) | 50.0000 | | - 0.0544i |
| 8 | 1.50 | 1.2500 $/50^\circ$ | 50.0000 | 1.8330 | + 0.0715i |
| 9 | 1.50 | 1.2000 $/40^\circ$ | 50.0000 | 1.8659 | + 0.0088i |
| 10 | 1.50 | 1.1500 $/30^\circ$ | 50.0000 | 1.8664 | + 0.0056i |
| 11 | 1.50 | 1.1000 $/20^\circ$ | 50.0000 | 1.8673 | + 0.0020i |
| 12 | 1.50 | 1.0500 $/10^\circ$ | 50.0000 | 1.8690 | - 0.0026i |
| 13 | 1.50 | 1.0000 $/0^\circ$ | 50.0000 | 1.8742 | - 0.0056i |

Example - 4 Cavities

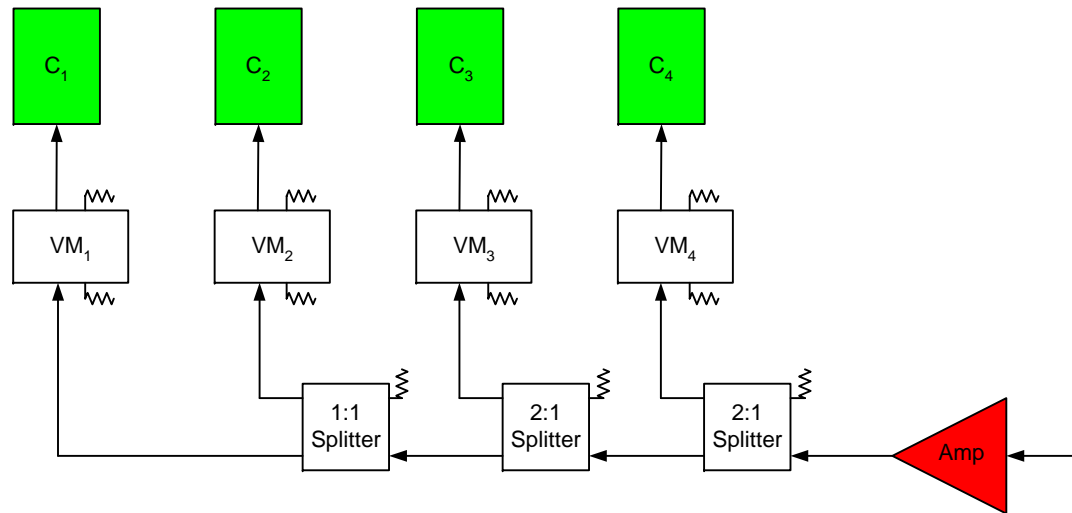

- Using vector modulators
 - Each VM employs two phase shifters and two hybrid power splitters

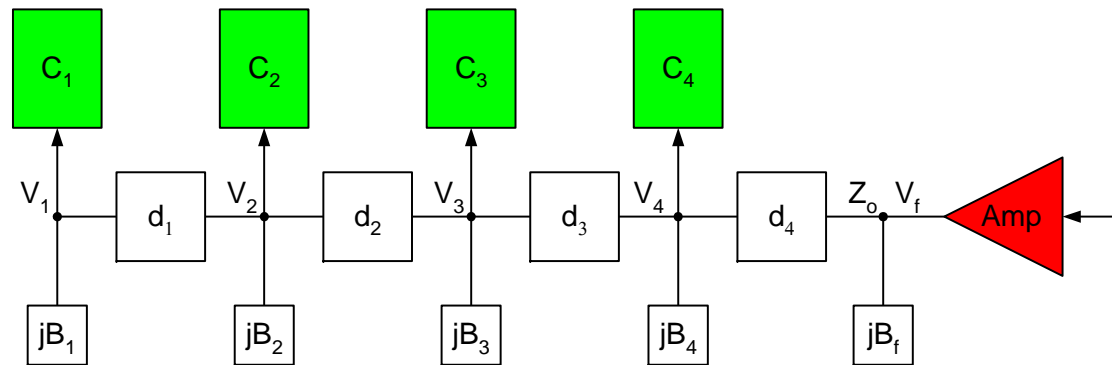

- Using proposed fan-out approach
 - Nine phase shifters are needed
 - No circulator is needed

Example - 4 Cavities

4 cavities @ $f = 402.5$ MHz
cavities are critically coupled

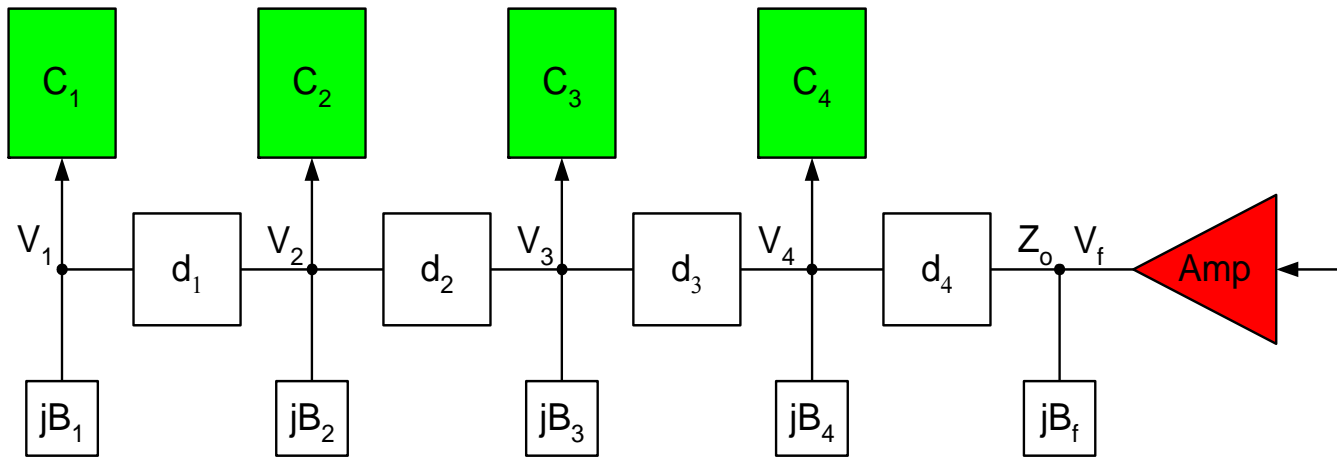

| Cavity | Distance (m) | Voltage (V) | Z_o (Ω) | d_i (m) | jB_i (Ω) |
|--------|--------------|--------------------------|--------------------|-----------|---------------------|
| 1 | 1.00 | 0.8000 $\angle 0^\circ$ | 50.00 | 1.5375 | - 0.0070i |
| 2 | 1.00 | 0.9000 $\angle 20^\circ$ | 50.00 | 1.5161 | - 0.0017i |
| 3 | 1.00 | 1.0000 $\angle 40^\circ$ | 50.00 | 1.5090 | + 0.0065i |
| 4 | 1.00 | 1.1000 $\angle 60^\circ$ | 50.00 | 1.4289 | + 0.0175i |
| 5 | | | (50.00 input) | | - 0.0233i |

Conclusion

- The proposed fan-out power distribution system can eliminate power overhead to achieve efficient operation
- The fan-out system can be controlled as a whole to deliver the exactly required amplitudes and phases of RF voltages at the cavities only with phase shifters
 - Any cavities missing or need to be disabled in the system can be set to have 0 voltage vector
- Phase delays and reactive loads at the cavity ports of the transmission line network are found by solving a network equation for a case using a standard transmission-line impedance
- This system can also be seen as an adjustable narrow-band N-port power splitter or impedance matching network
- The phase delays and reactive loadings can be realized by using high power fast phase shifters
 - System bandwidth will still be dependent on the response of High power fast phase shifters are necessary
- For practical waveguides, slight modification of the system admittance matrices will have to be made