



CLIC: A Compact Linear Collider

International Conference on New Frontiers in Physics 2013
Aug. 28 to Sept. 5, Kolymbari, Crete

Samir Arfaoui [CERN/PH-LCD]
samir.arfaoui@cern.ch
on behalf of the CLIC Detector and Physics Study

- CLIC Concept, Accelerator and Detectors
- Higgs studies
- Top physics
- Beyond the Standard Model
- Summary



- Pre-collaboration structure based on "Memorandum of Cooperation" (MoC):
<http://lcd.web.cern.ch/lcd/Home/MoC.html>
- CERN acts as host laboratory
- **At the moment 17 institutes from 14 countries, more contributors most welcome!**
[The accelerator R&D is being conducted in collaboration with ~48 institutes]

CLIC: The most mature option for a multi-TeV e^+e^- collider

CLIC Accelerator:

- Staged construction \sqrt{s} from ~ 350 GeV to 3 TeV
- Two-beam acceleration scheme
- RF operated at room temperature
- Polarised electron beam, luminosity $> 10^{34} \text{ cm}^{-2}\text{s}^{-1}$

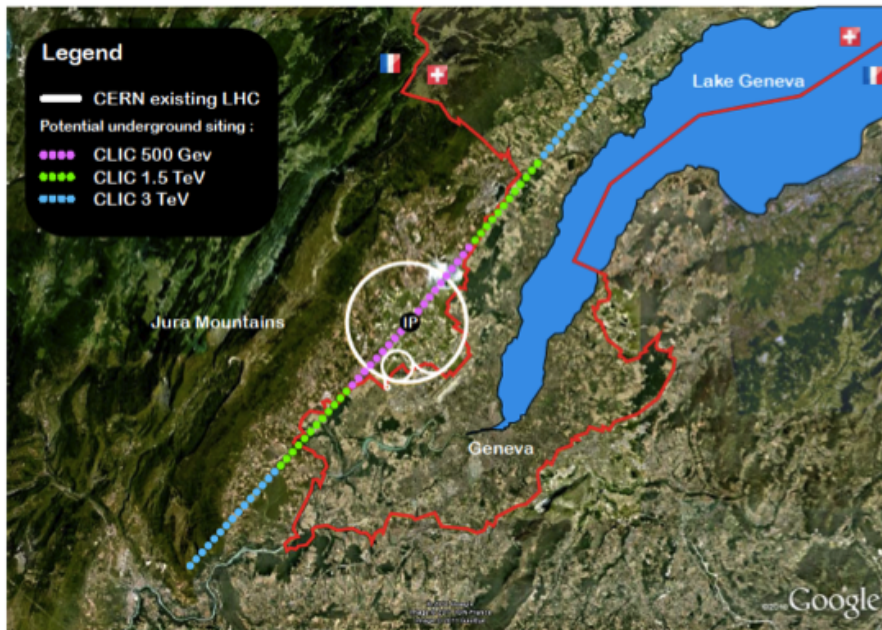
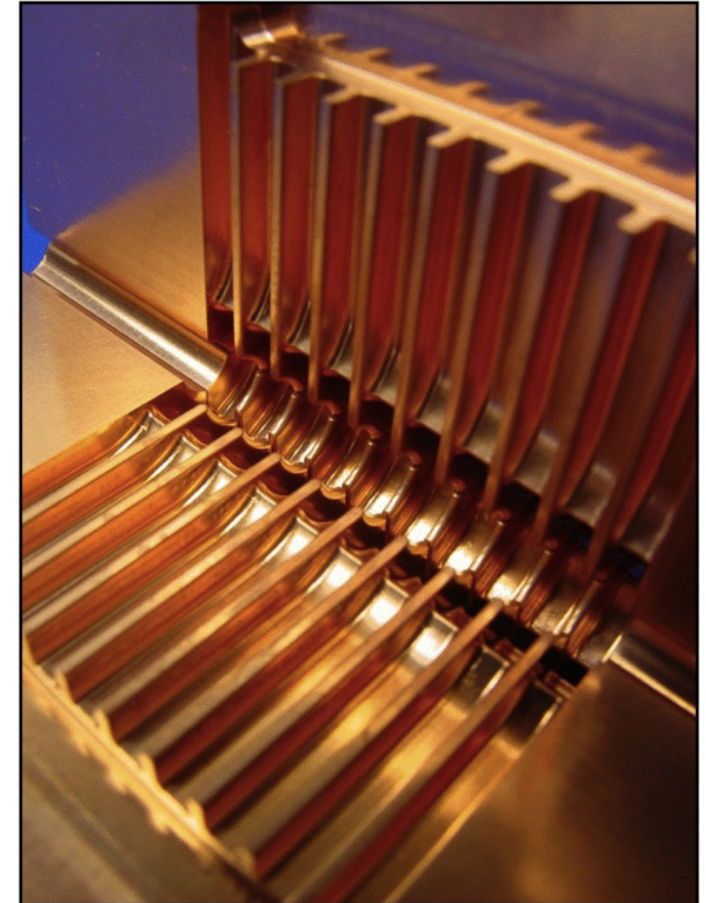
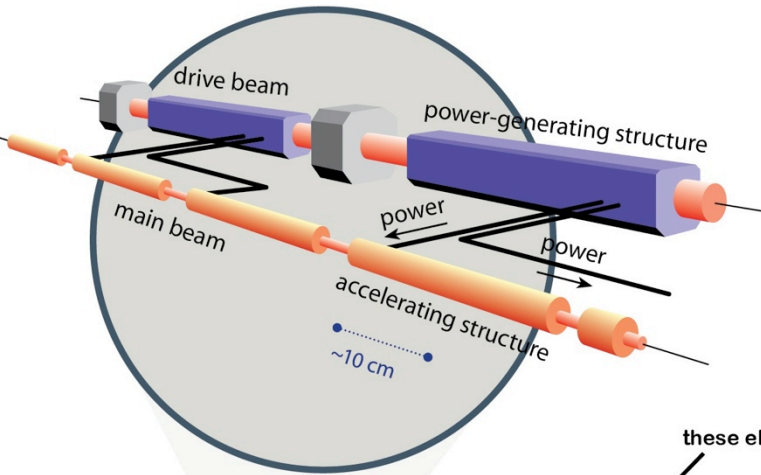

Fig. 7.2: CLIC footprints near CERN, showing various implementation stages [5].



Two-beam acceleration scheme

Accelerating gradient:
100 MV/m



Drive beam supplies RF power

- low energy (2.4 GeV - 240 MeV)
- high current (100A)

Main beam for physics

- high energy (9 GeV - 1.5 TeV)
- low current 1.2 A

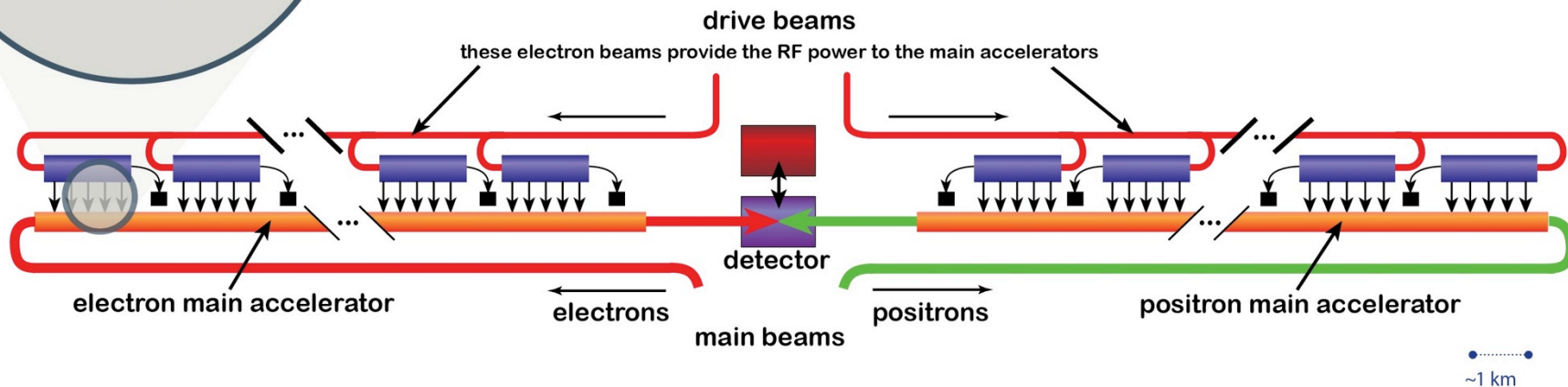

Two detector concepts based on ILC designs, adapted to CLIC conditions:

- ultra low mass vertexing and tracking
- highly granular calorimetry designed for Particle Flow Analysis
- 4-5 T solenoidal magnetic field

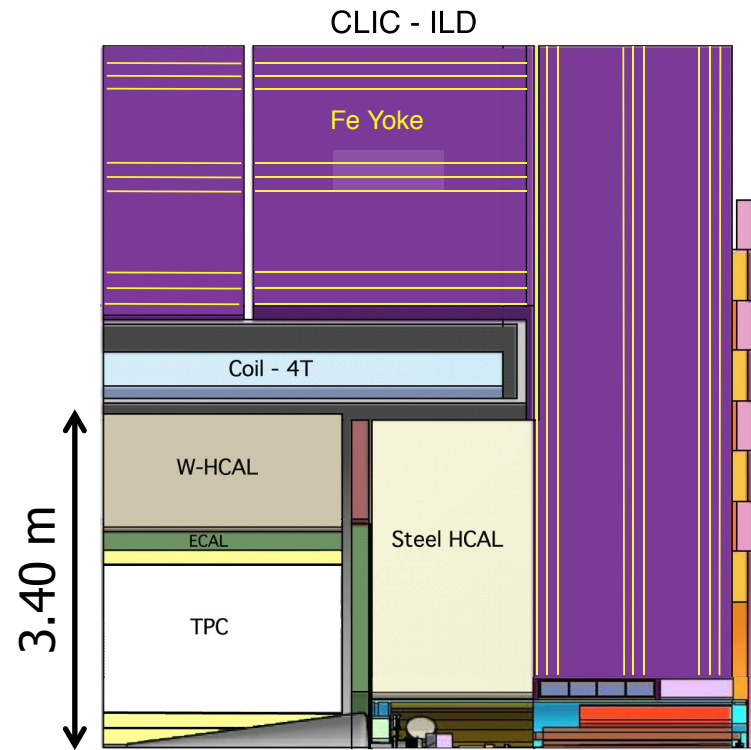
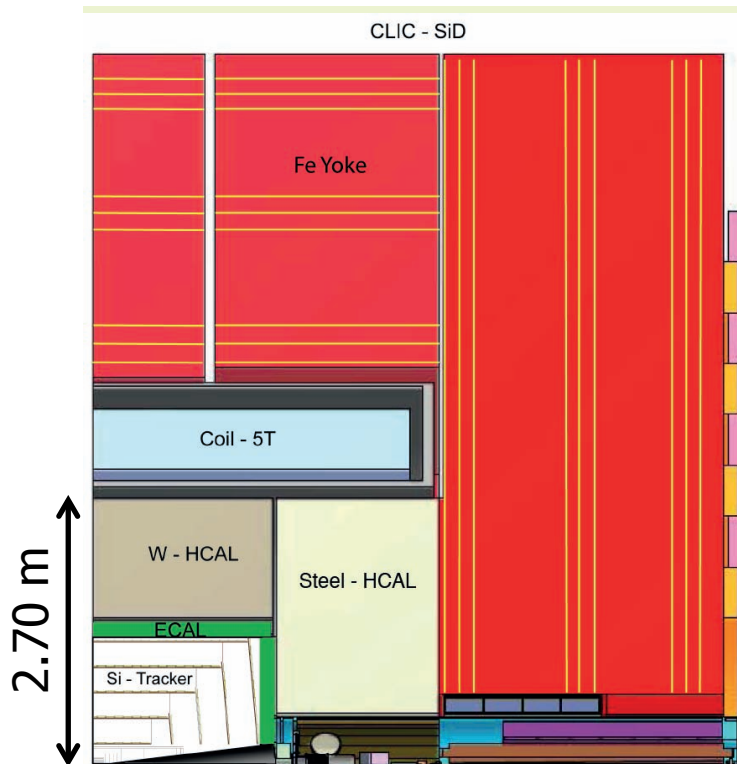

The results shown on the following slides were obtained using full detector simulations (Geant4)

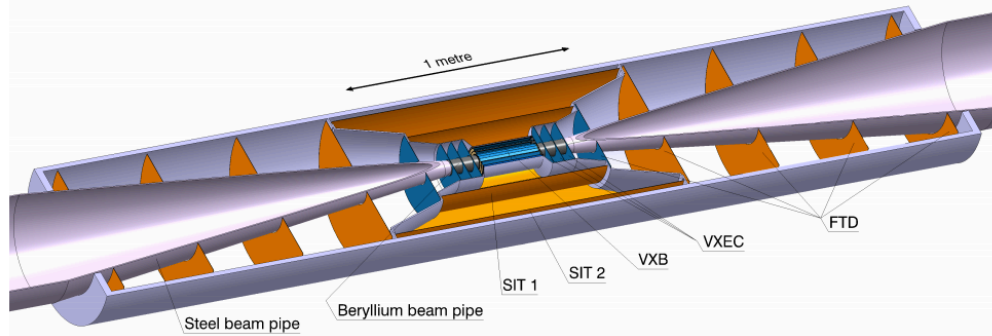

Calorimetry

- High granularity designed for Particle Flow: "see" every contribution to the shower
- EM calorimeter
 - Thin Tungsten absorber plates
 - Silicon and/or scintillators options
- Hadronic calorimeter
 - Tungsten / Steel absorbers
 - Scintillators coupled to SiPM for analog readout (see picture of the A-HCAL prototype during test beam at CERN)
 - RPCs for digital / semi-digital readout

Vertex detector

- Good single point resolution
 - $\sigma_{SP} \sim 3 \mu\text{m}$
 - Small pixels $\sim 25 \times 25 \mu\text{m}^2$
- Time stamping with $\sim 10 \text{ ns}$ accuracy to reject background
- Low material budget
 - $X \approx 0.2\% X_0 / \text{layer}$
 - Corresponds to $\sim 200 \mu\text{m Si}$
 - Air-flow cooling + Low-power ASICs ($\sim 50 \text{ mW/cm}^2$)

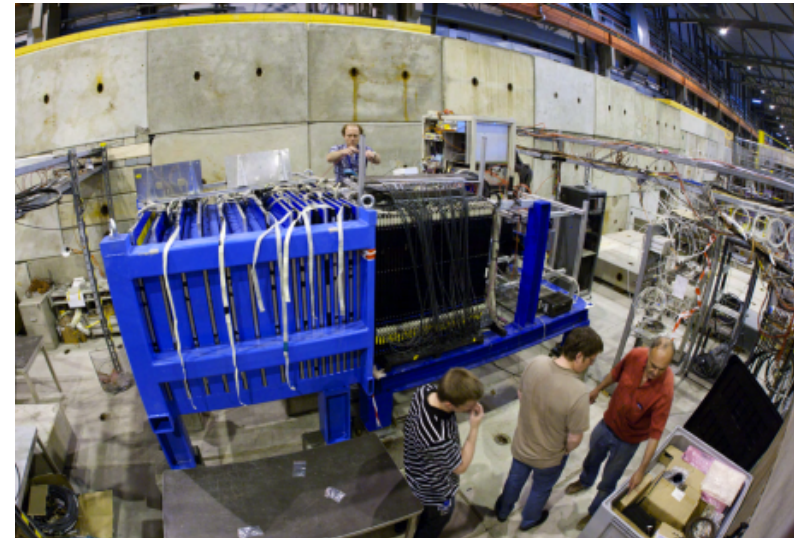

CLIC energy staging

- CLIC will be implemented in stages: optimised running conditions over a wide energy range
- **The energy stages will be defined** by physics with additional technical considerations
 - strategy can be adapted to discoveries at the LHC

Currently studied example scenario:

- **Stage 1:** 350/375 GeV, 500 fb⁻¹

HZ cross section, mass, H $\nu_e\bar{\nu}_e$ contribution sizeable, various branching ratios, *top threshold scan*

- **Stage 2:** 1.4 TeV, 1.5 ab⁻¹

BSM physics, ttH, Higgs self-coupling, rare Higgs decays

- **Stage 3:** 3 TeV, 2 ab⁻¹

BSM physics, Higgs self-coupling, rare Higgs decays

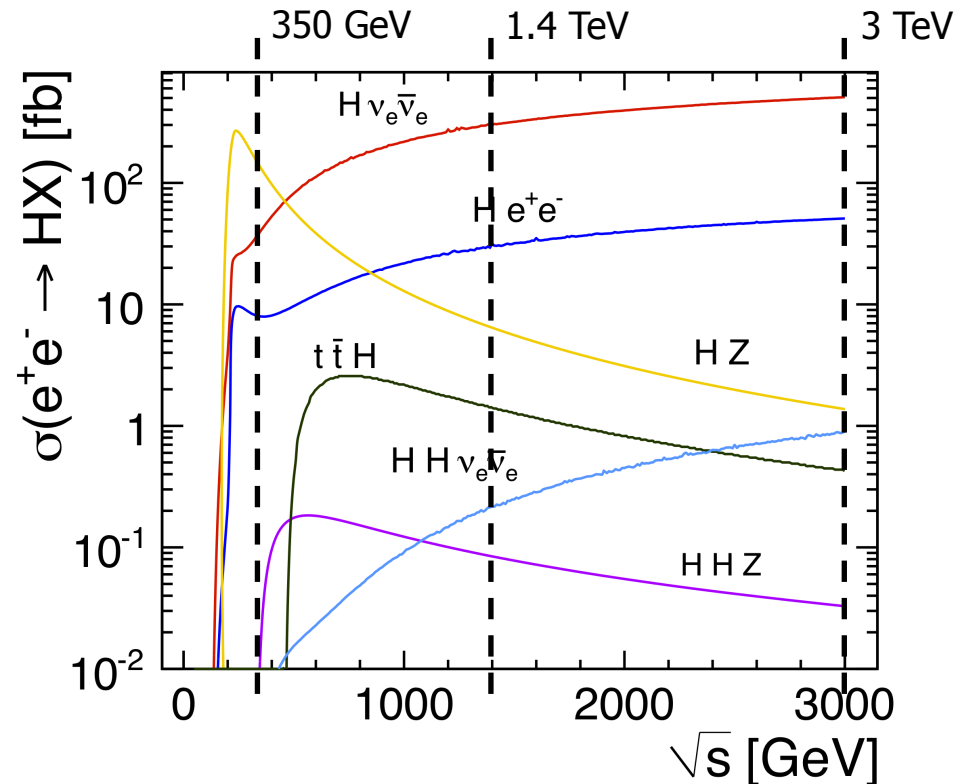

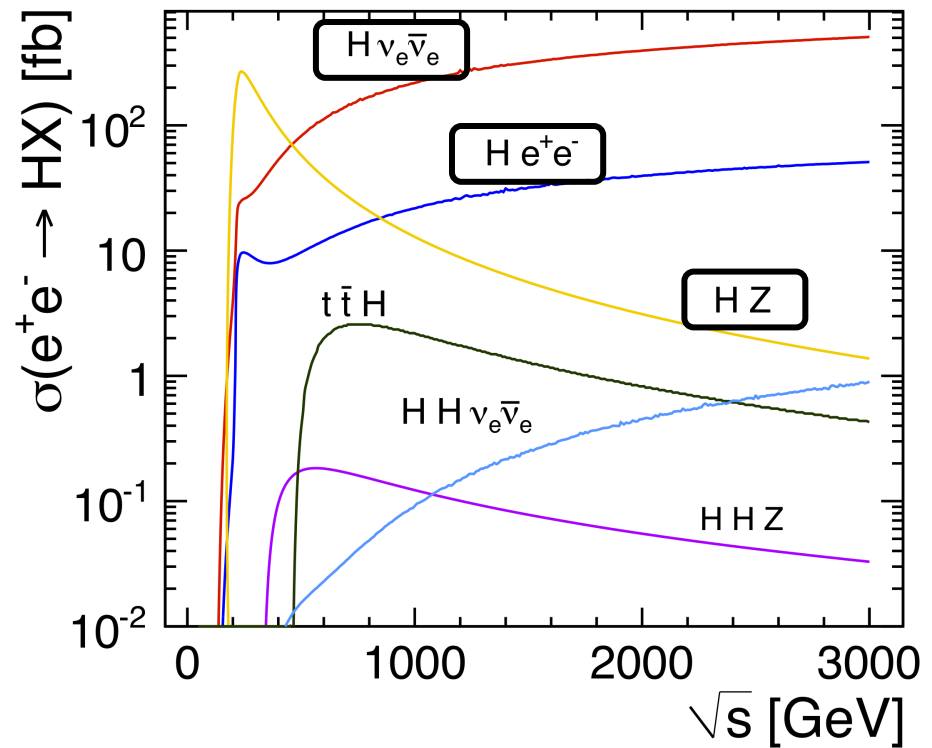
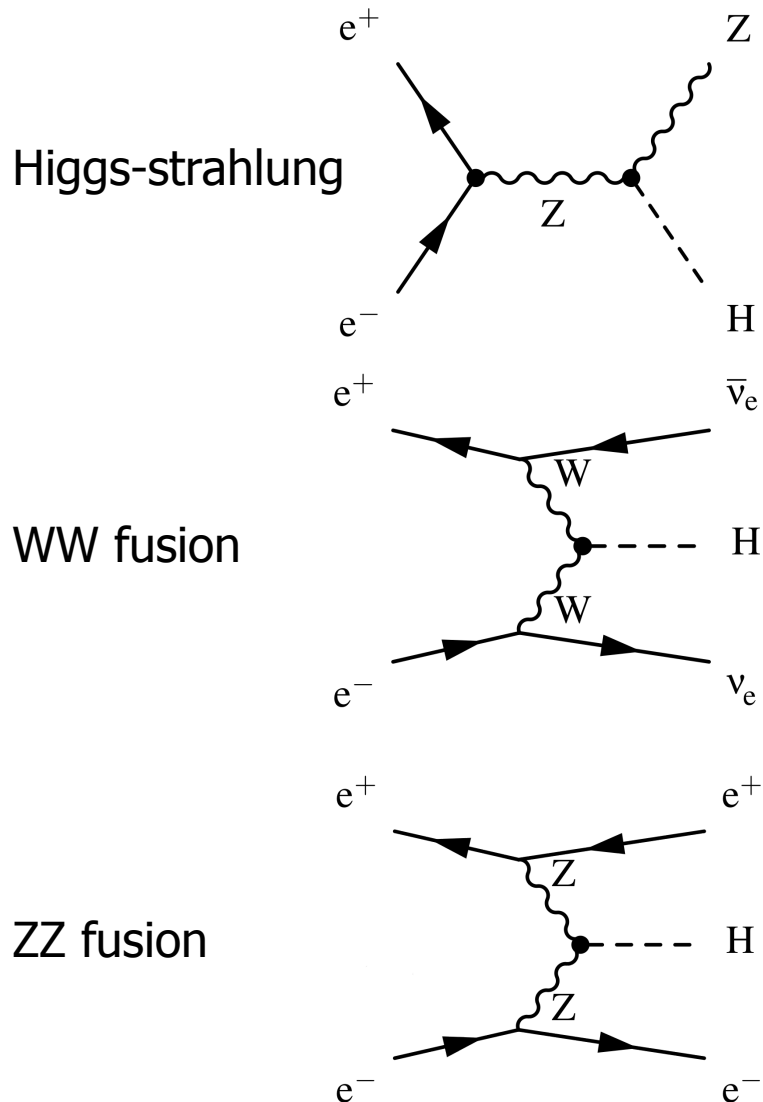

	350 GeV	1.4 TeV	3 TeV
$e^+e^- \rightarrow HZ$	134 fb	9 fb	2 fb
$e^+e^- \rightarrow H\nu\nu$	52 fb	279 fb	479 fb
$e^+e^- \rightarrow He^+e^-$	7 fb	28 fb	49 fb

Cross-sections with unpolarised beams

ttH production

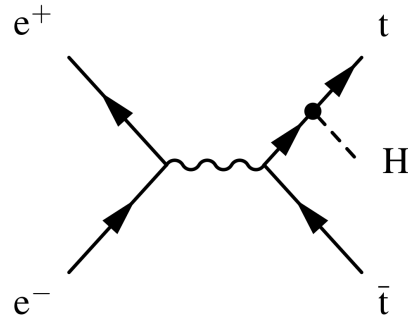

Double Higgs production

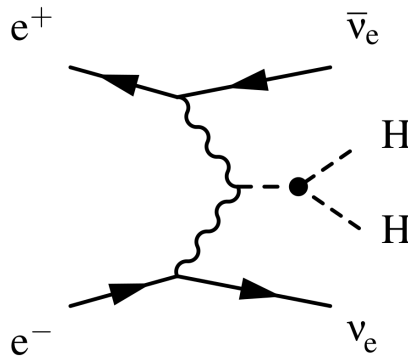

Quartic WWHH coupling

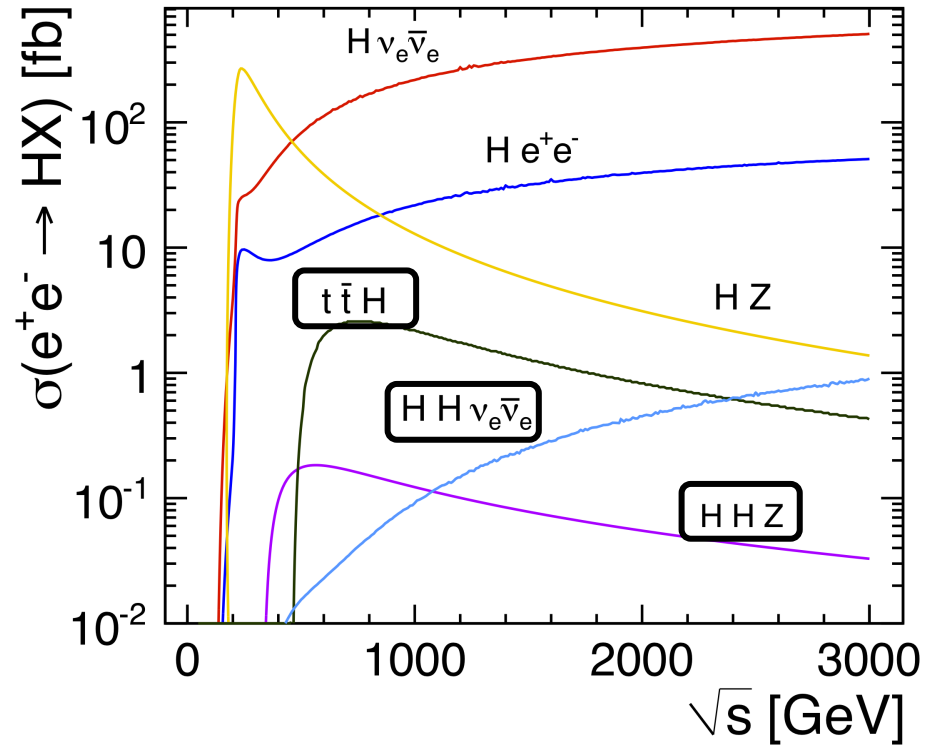
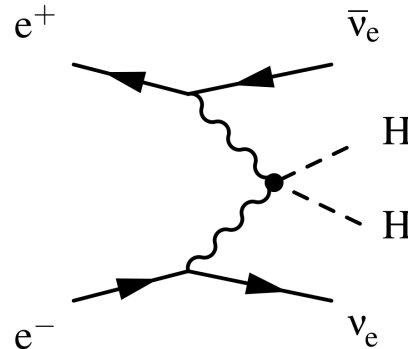

	1.4 TeV	3 TeV
$e^+e^- \rightarrow ttH$	1.6 fb	-
$e^+e^- \rightarrow HH\nu\nu$	0.164 fb	0.63 fb

Cross-sections with unpolarised beams

Measurements at 350 GeV

Higgs-strahlung process allows for Higgs mass reconstruction from Z recoil mass:

- Model independent measurement of m_H and g_{HZZ} coupling

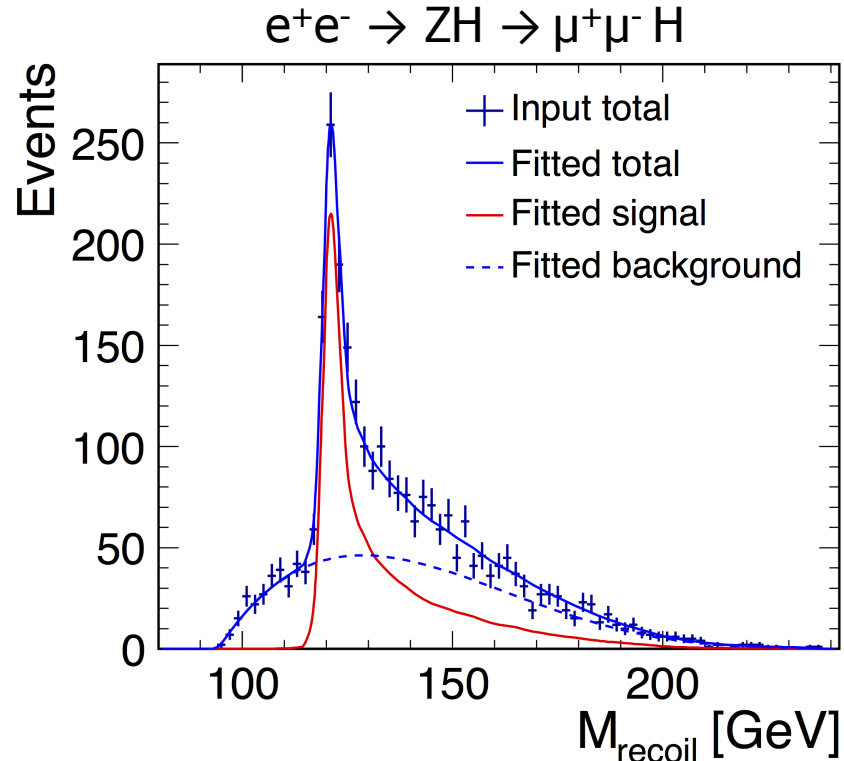
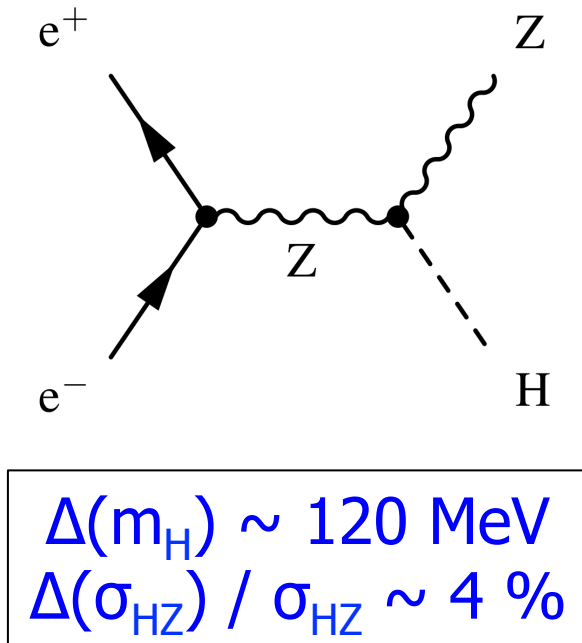

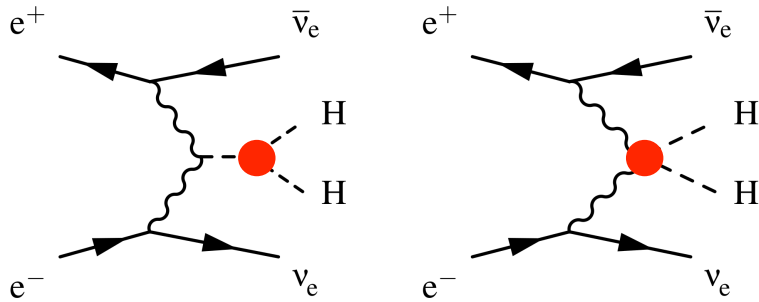

- The $HH\nu_e\bar{\nu}_e$ cross section is sensitive to the Higgs self-coupling, λ , and the quartic g_{HHWW} coupling

- $\sigma(HH\nu_e\bar{\nu}_e) = 0.15$ (0.59) fb at 1.4 (3) TeV
 → high energy and luminosity crucial

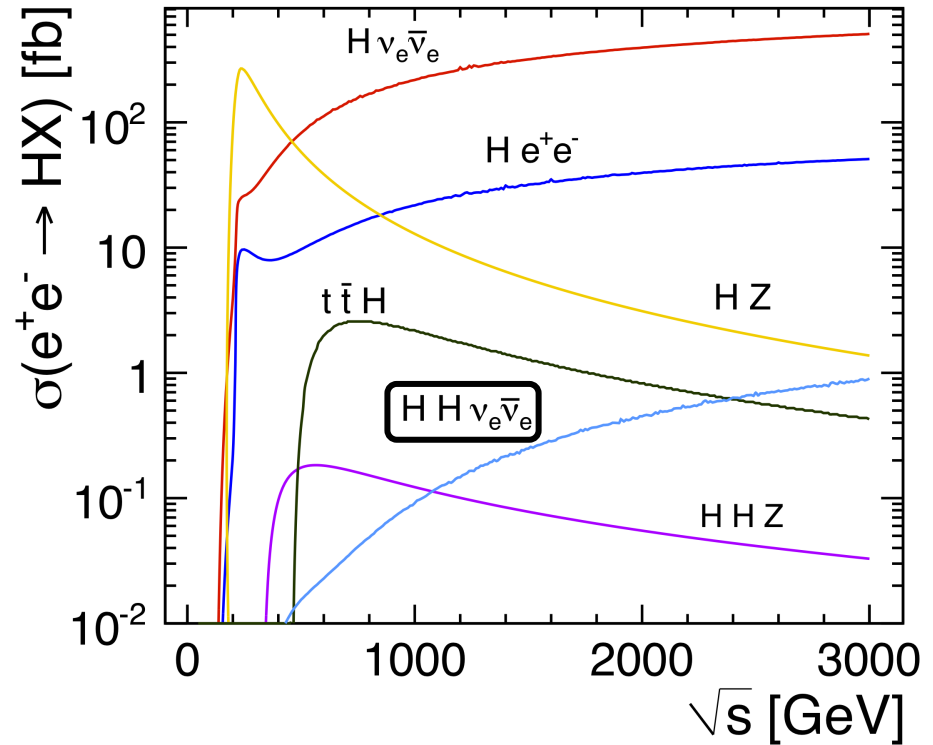

	1.4 TeV	3 TeV
$\Delta(g_{HHWW})$	7% (preliminary)	3% (preliminary)
$\Delta(\lambda)$	28%	16%
$\Delta(\lambda)$ for $p(e^-) = 80\%$	21%	12%

Global fit to Higgs results

Model-independent global fit to all of the experimental measurements involving the Higgs boson couplings

Alternative:

Assuming no invisible Higgs decays, define couplings scaling factors and total width

$$\kappa_i^2 = \frac{\Gamma_i}{\Gamma_i|_{SM}}$$

$$\Gamma_{H,md} = \sum_i \kappa_i^2 BR_i$$

→ Model-dependent global fit

Parameter	Measurement precision		
	350 GeV 500 fb ⁻¹	+1.4 TeV +1.5 ab ⁻¹	+3.0 TeV +2.0 ab ⁻¹
m_H	120 MeV	30 MeV	20 MeV
Γ_H	9.2%	8.5%	8.4%
λ	—	21%	10%
g_{HZZ}	2.1%	2.1%	2.1%
g_{HWW}	2.6%	2.1%	2.1%
g_{Hbb}	2.7%	2.1%	2.1%
g_{Hcc}	3.8%	2.3%	2.2%
$g_{H\tau\tau}$	4.0%	2.5%	tbd
$g_{H\mu\mu}$	—	10.7%	5.6%
g_{Htt}	—	4.5%	tbd

Parameter	Measurement precision		
	350 GeV 500 fb ⁻¹	+1.4 TeV +1.5 ab ⁻¹	+3.0 TeV +2.0 ab ⁻¹
$\Gamma_{H,model}$	1.6%	0.29%	0.22%
κ_{HZZ}	0.49%	0.33%	0.24%
κ_{HWW}	1.5%	0.15%	0.11%
κ_{Hbb}	1.7%	0.32%	0.19%
κ_{Hcc}	3.1%	1.1%	0.75%
$\kappa_{H\tau\tau}$	3.5%	1.4%	tbd
$\kappa_{H\mu\mu}$	—	10.5%	5.2%
κ_{Htt}	—	4.0%	tbd
κ_{Hgg}	3.6%	0.79%	0.56%
$\kappa_{H\gamma\gamma}$	—	5.5%	tbd

... however precision on couplings is constrained by precision on g_{HZZ}

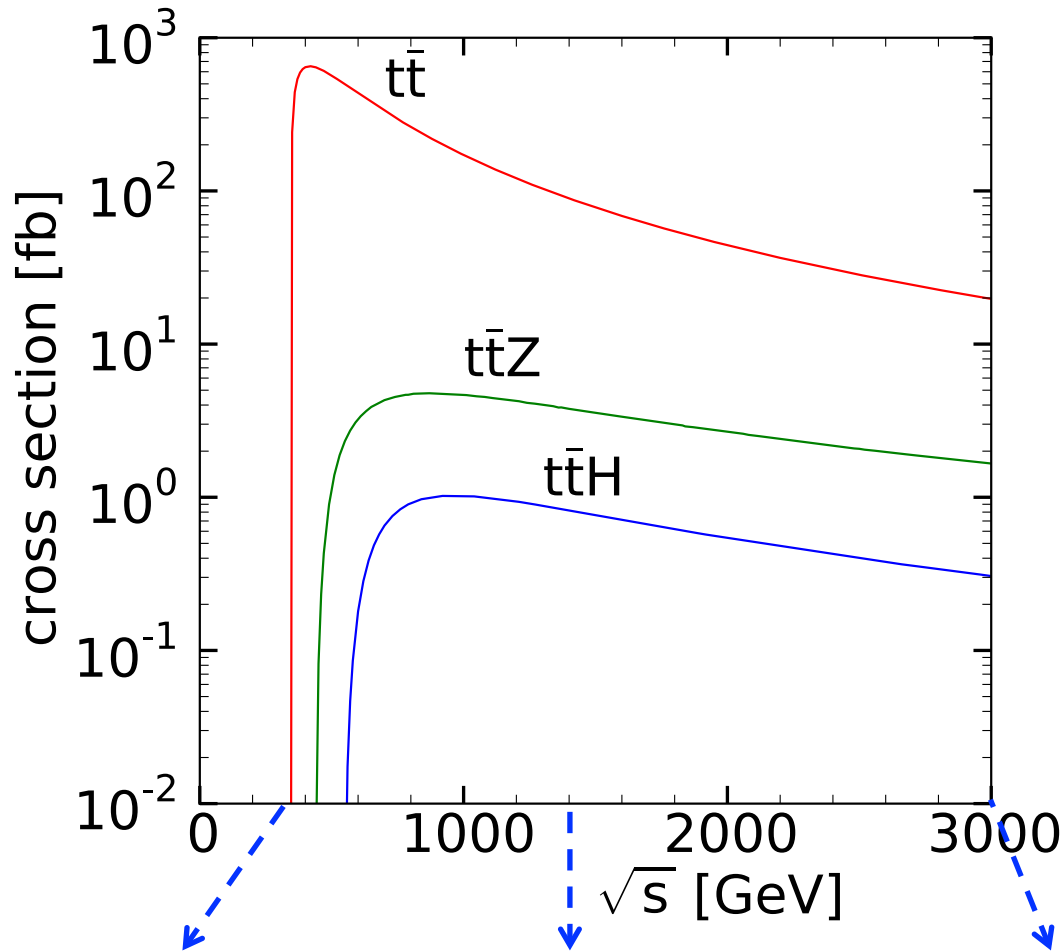

Stage 1: $\sqrt{s} = \sim 375$ GeV
 Top mass measurement
 and threshold scan

Stage 2: $\sqrt{s} = 1.4$ TeV
 Top Yukawa coupling

Stage 3: $\sqrt{s} = 3$ TeV
 Top in combination
 with new physics

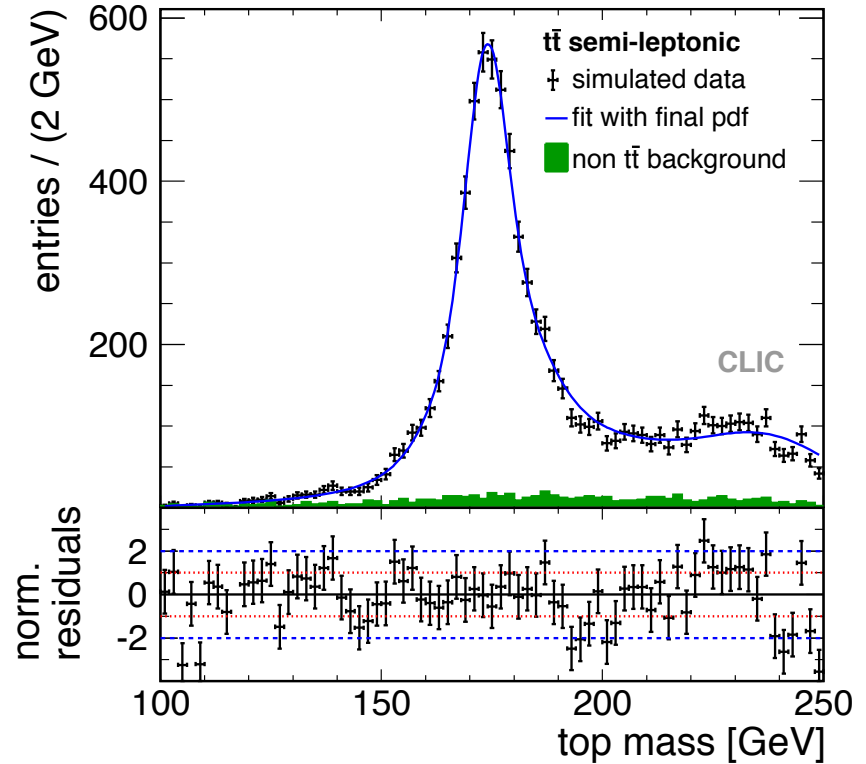
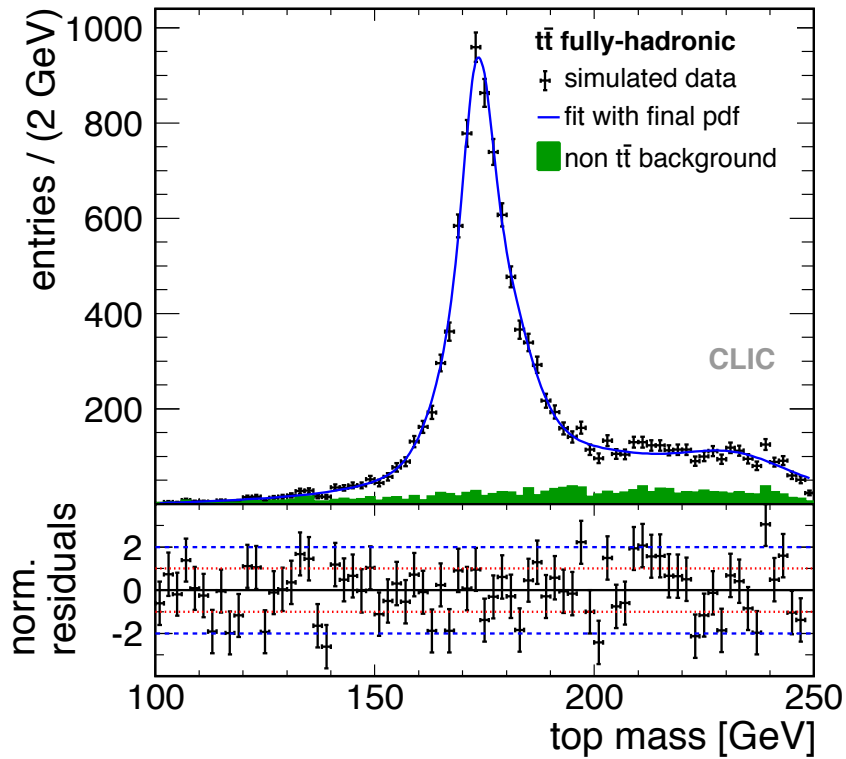

channel	m_{top}	Δm_{top}	Γ_{top}	$\Delta\Gamma_{\text{top}}$
fully-hadronic	174.049	0.099	1.47	0.27
semi-leptonic	174.293	0.137	1.70	0.40
combined	174.133	0.080	1.55	0.22

- Pure NNLO cross section (calculated with TOPPIK [Hoang & Teubner]) distorted by **ISR** and **Luminosity Spectrum (LS)**
- Combined with selection efficiency and background contamination from full simulations: simulated data points
- **Expected statistical error on top mass ~ 34 MeV (total ~ 100 MeV)**

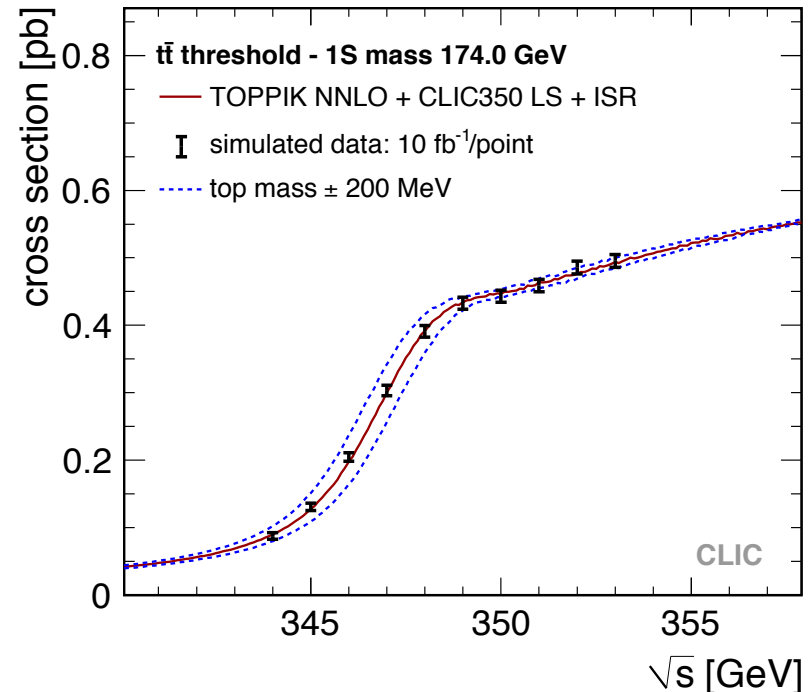
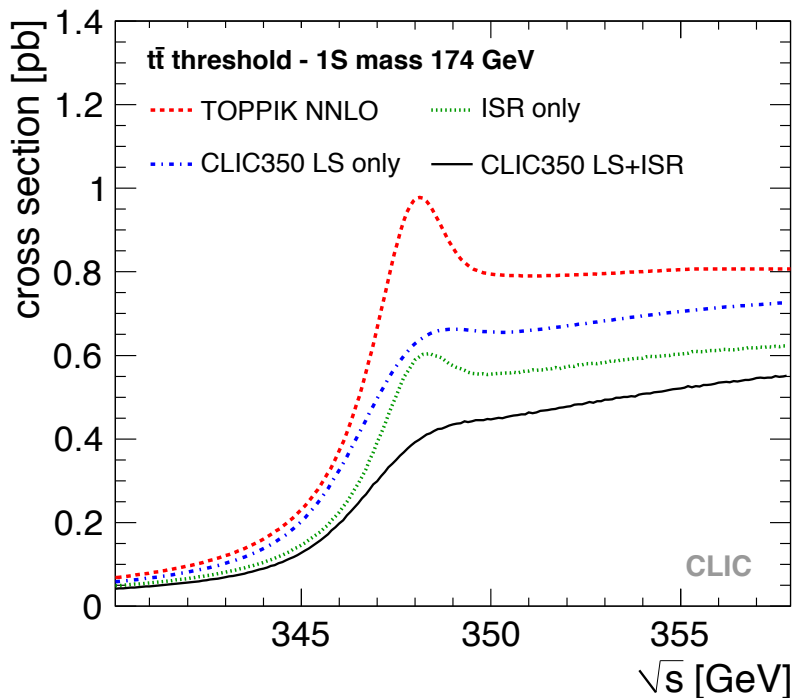

Three different models have been investigated, selected to show performance for various different physics channels and at different energies

Model I: 3 TeV studies

Model III: 1.4 TeV studies

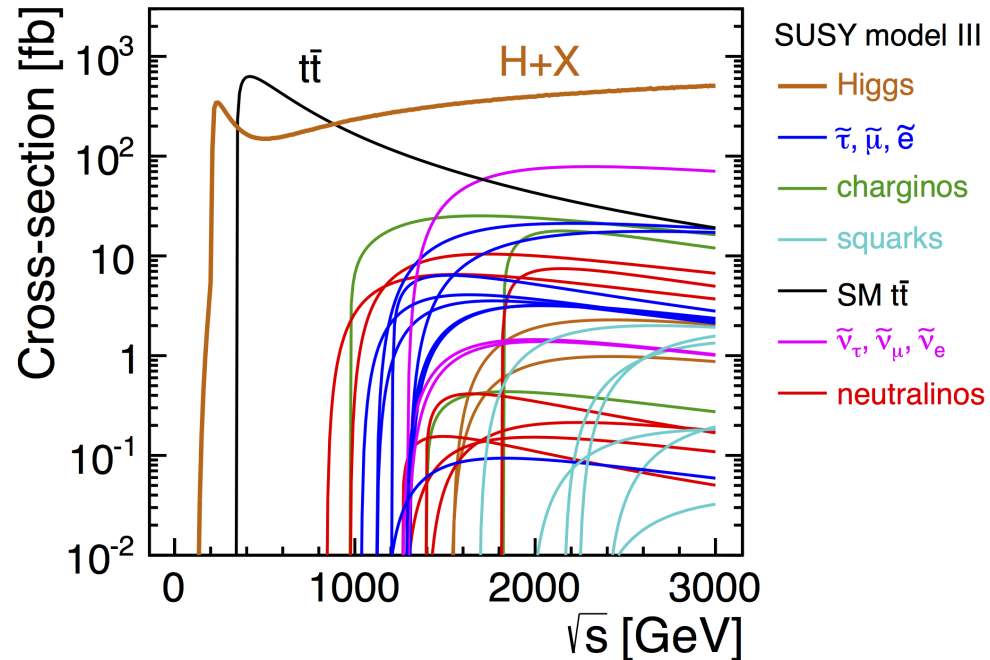
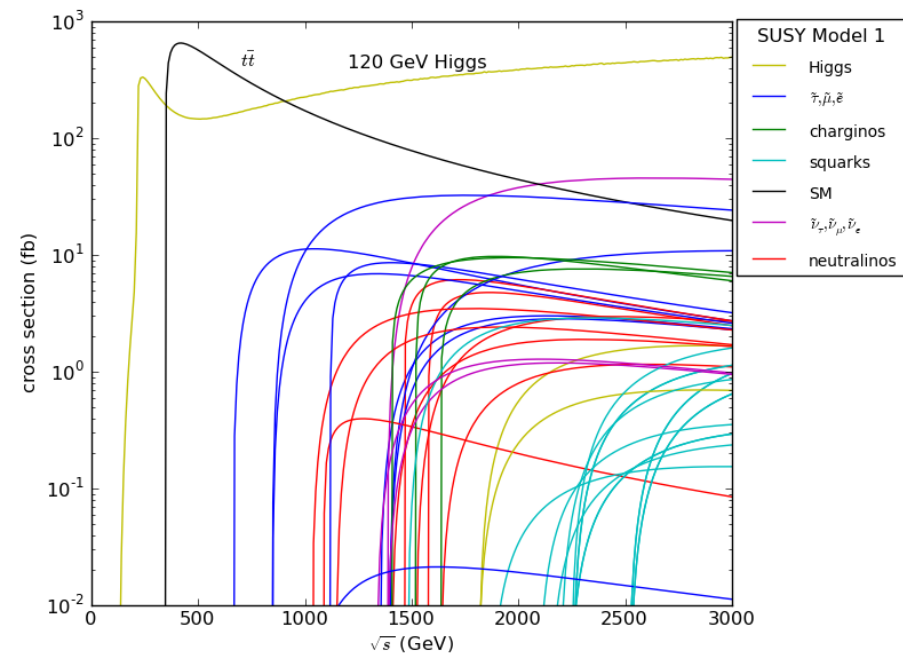

Example: $e^+ e^- \rightarrow \tilde{\chi}_1^+ \tilde{\chi}_1^- \rightarrow W^+ W^- \tilde{\chi}_1^0 \tilde{\chi}_1^0$

Model: Chargino mass ~ 490 GeV

Reconstruction in the full-hadronic final state:
4 jets + missing energy

Challenge:
Reconstruction of low-energy jets in high background environment

Momentum and timing selection cuts on particle flow objects are able to clean up invariant mass distributions very effectively

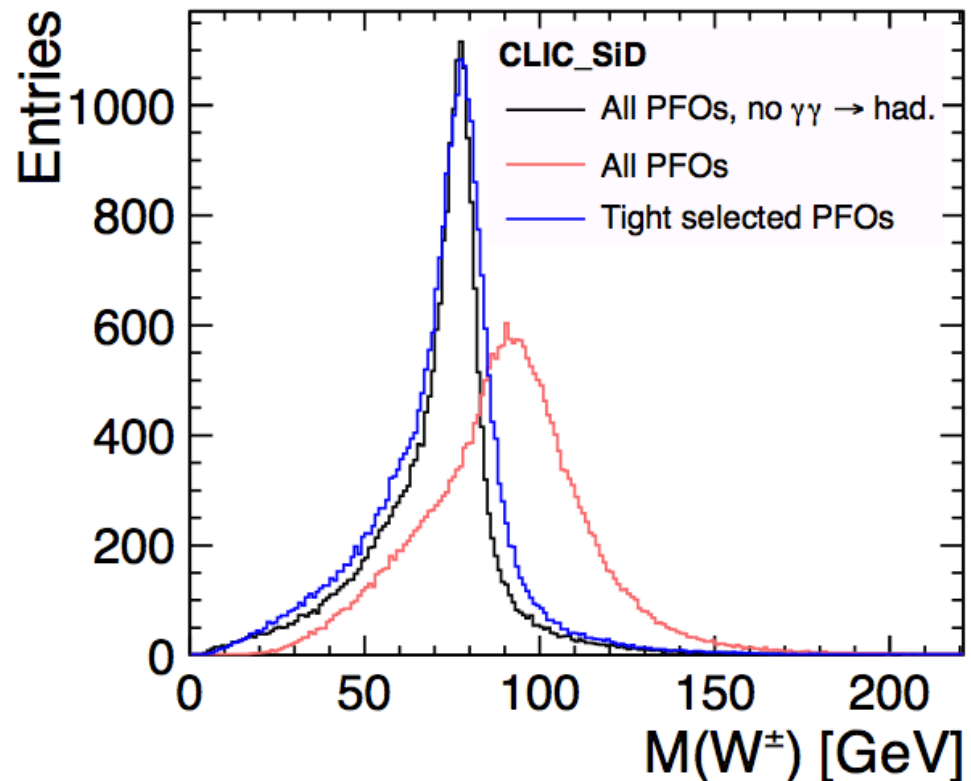

Final states: four b-jets, and two tops + two b jets (8 jet final state)

Model: mass scale for neutral and charged heavy Higgs H^0 , A , H^\pm : 900 GeV

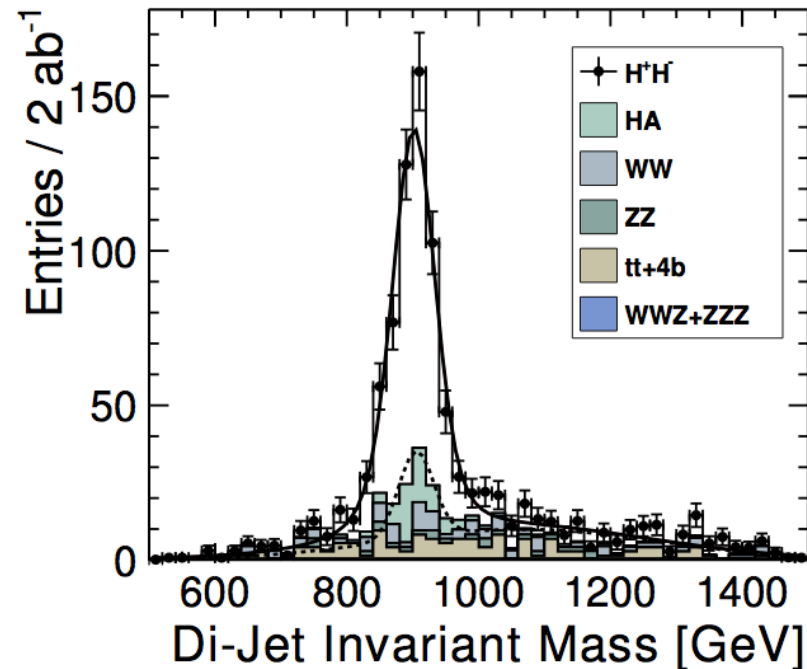
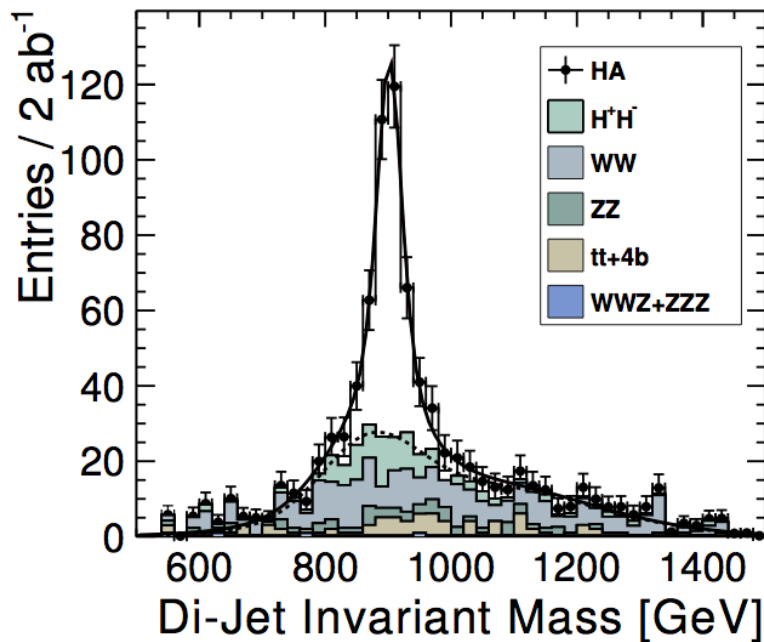

Masses can be determined with a statistical precision of 0.3% (2 GeV)

Widths at the 20% level (6 GeV)

Sensitivity to Z'

Sensitivity to small asymmetries in total cross-section, backward-forward kinematics, and polarisation in the very clean $e^+e^- \rightarrow \mu^+\mu^-$ channel

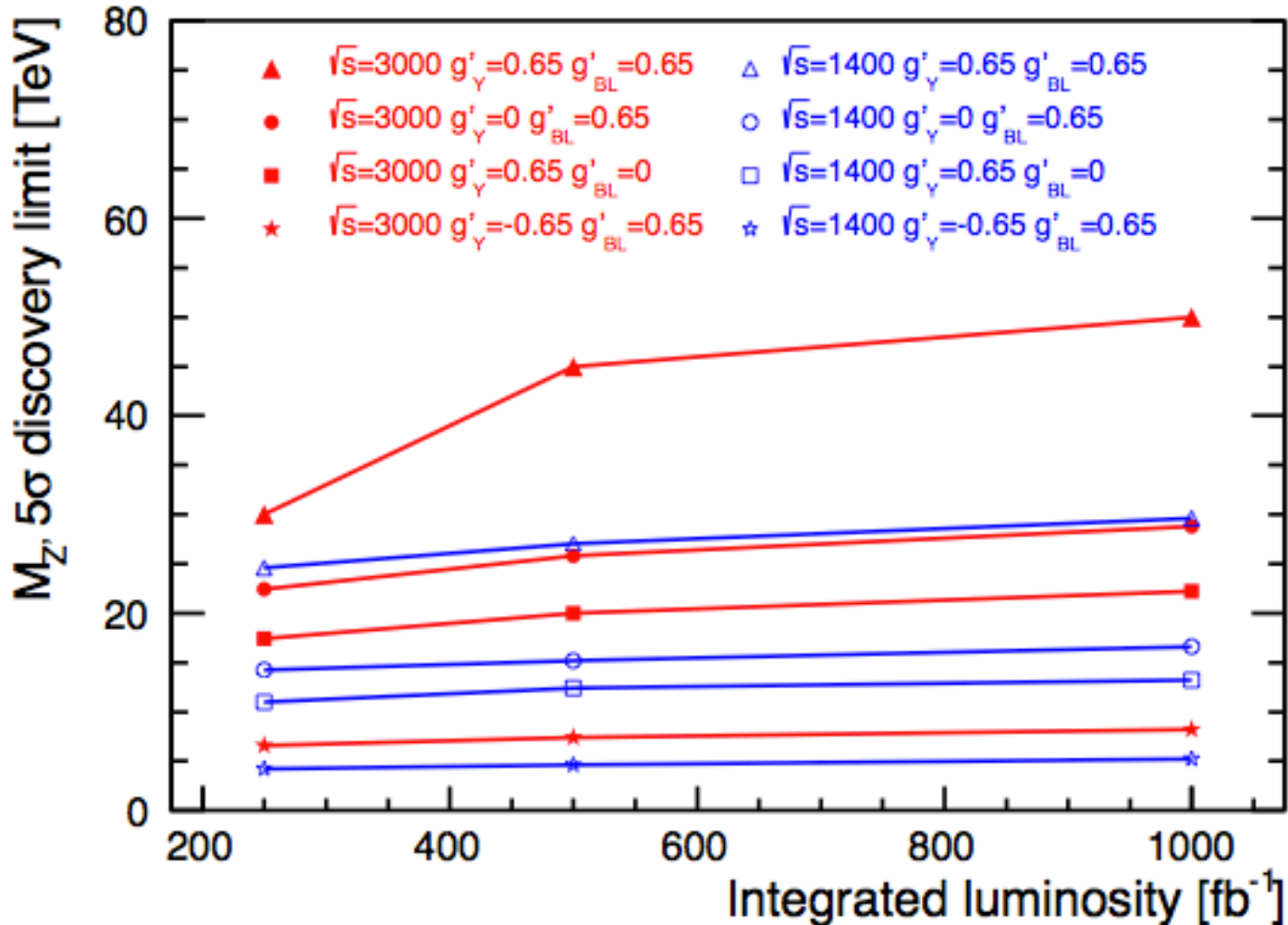

- CLIC is the most mature option for a multi-TeV e^+e^- collider
- Very active R&D projects are ongoing for both accelerator and detector technologies
- Energy staging will allow operation of the machine during its extension, with possible stages at 350 GeV, 1.4, and 3 TeV
- CLIC @ 350 GeV
 - Precision Higgs measurements: mass, branching ratios, ...
 - Operation at and above the $t\bar{t}$ threshold: two complementary measurements of the top mass
 - Direct reconstruction using the invariant mass distribution + Threshold scan
 - Experimental uncertainties: $O(100 \text{ MeV})$ for 100 fb^{-1} of data
- CLIC @ 1.4 and 3 TeV
 - Improved precision of many observables and access to rare Higgs decays
 - Trilinear Higgs self-coupling at the 10% level
 - Top Yukawa coupling with $t\bar{t}H$
 - As a discovery machine for BSM physics at the energy frontier
 - Direct sensitivity to strong and electroweak particles up to $\sim 1.5 \text{ TeV}$ (SUSY)
 - Indirect sensitivity up to tens of TeV (ex: heavy Z')

- CLIC Detector and Physics Study
 - <http://lcd.web.cern.ch/lcd/Welcome.html>
- CDR Volume II: Physics and Detectors at CLIC
 - [arXiv 1202.5940](https://arxiv.org/abs/1202.5940)
- CDR Volume III: Towards a staged Linear e^+e^- Collider Exploring the Terascale
 - [arXiv 1209.2543](https://arxiv.org/abs/1209.2543)
- Physics at the CLIC e^+e^- Linear Collider – Input to the Snowmass process
 - [arXiv 1307.5288](https://arxiv.org/abs/1307.5288)

Thank you for your attention

Backup

Channel	Measurement	Observable	Statistical precision		
			350 GeV 500 fb ⁻¹	1.4 TeV 1.5 ab ⁻¹	3.0 TeV 2.0 ab ⁻¹
ZH	Recoil mass distribution	m_H	120 MeV	–	–
ZH	$\sigma(\text{HZ}) \times BR(\text{H} \rightarrow \text{invisible})$	Γ_{inv}	tbd	–	–
ZH	H \rightarrow $b\bar{b}$ mass distribution	m_H	tbd	–	–
Hv _e $\bar{\nu}_e$	H \rightarrow $b\bar{b}$ mass distribution	m_H	–	40 MeV*	33 MeV*
ZH	$\sigma(\text{HZ}) \times BR(\text{Z} \rightarrow \ell^+ \ell^-)$	g_{HZZ}^2	4.2%	–	–
ZH	$\sigma(\text{HZ}) \times BR(\text{H} \rightarrow b\bar{b})$	$g_{\text{HZZ}}^2 g_{\text{Hbb}}^2 / \Gamma_H$	1% [†]	–	–
ZH	$\sigma(\text{HZ}) \times BR(\text{H} \rightarrow c\bar{c})$	$g_{\text{HZZ}}^2 g_{\text{Hcc}}^2 / \Gamma_H$	5% [†]	–	–
ZH	$\sigma(\text{HZ}) \times BR(\text{H} \rightarrow g\bar{g})$		6% [†]	–	–
ZH	$\sigma(\text{HZ}) \times BR(\text{H} \rightarrow \tau^+ \tau^-)$	$g_{\text{HZZ}}^2 g_{\text{H}\tau\tau}^2 / \Gamma_H$	5.7%	–	–
ZH	$\sigma(\text{HZ}) \times BR(\text{H} \rightarrow \text{WW}^*)$	$g_{\text{HZZ}}^2 g_{\text{HWW}}^2 / \Gamma_H$	2% [†]	–	–
ZH	$\sigma(\text{HZ}) \times BR(\text{H} \rightarrow \text{ZZ}^*)$	$g_{\text{HZZ}}^2 g_{\text{HZZ}}^2 / \Gamma_H$	tbd	–	–
Hv _e $\bar{\nu}_e$	$\sigma(\text{Hv}_e \bar{\nu}_e) \times BR(\text{H} \rightarrow b\bar{b})$	$g_{\text{HWW}}^2 g_{\text{Hbb}}^2 / \Gamma_H$	3% [†]	0.3%	0.2%
Hv _e $\bar{\nu}_e$	$\sigma(\text{Hv}_e \bar{\nu}_e) \times BR(\text{H} \rightarrow c\bar{c})$	$g_{\text{HWW}}^2 g_{\text{Hcc}}^2 / \Gamma_H$	–	2.9%	2.7%
Hv _e $\bar{\nu}_e$	$\sigma(\text{Hv}_e \bar{\nu}_e) \times BR(\text{H} \rightarrow g\bar{g})$		–	1.8%	1.8%
Hv _e $\bar{\nu}_e$	$\sigma(\text{Hv}_e \bar{\nu}_e) \times BR(\text{H} \rightarrow \tau^+ \tau^-)$	$g_{\text{HWW}}^2 g_{\text{H}\tau\tau}^2 / \Gamma_H$	–	3.7%	tbd
Hv _e $\bar{\nu}_e$	$\sigma(\text{Hv}_e \bar{\nu}_e) \times BR(\text{H} \rightarrow \mu^+ \mu^-)$	$g_{\text{HWW}}^2 g_{\text{H}\mu\mu}^2 / \Gamma_H$	–	28%*	16%
Hv _e $\bar{\nu}_e$	$\sigma(\text{Hv}_e \bar{\nu}_e) \times BR(\text{H} \rightarrow \gamma\gamma)$		–	15%*	tbd
Hv _e $\bar{\nu}_e$	$\sigma(\text{Hv}_e \bar{\nu}_e) \times BR(\text{H} \rightarrow \text{Z}\gamma)$		–	tbd	tbd
Hv _e $\bar{\nu}_e$	$\sigma(\text{Hv}_e \bar{\nu}_e) \times BR(\text{H} \rightarrow \text{WW}^*)$	$g_{\text{HWW}}^4 / \Gamma_H$	tbd	1% [†]	0.7% [†]
Hv _e $\bar{\nu}_e$	$\sigma(\text{Hv}_e \bar{\nu}_e) \times BR(\text{H} \rightarrow \text{ZZ}^*)$	$g_{\text{HWW}}^2 g_{\text{HZZ}}^2 / \Gamma_H$	–	3% [†]	2% [†]
He ⁺ e ⁻	$\sigma(\text{He}^+ \text{e}^-) \times BR(\text{H} \rightarrow b\bar{b})$	$g_{\text{HZZ}}^2 g_{\text{Hbb}}^2 / \Gamma_H$	–	1% [†]	0.7% [†]
t \bar{t} H	$\sigma(\text{t}\bar{t}\text{H}) \times BR(\text{H} \rightarrow b\bar{b})$	$g_{\text{Htt}}^2 g_{\text{Hbb}}^2 / \Gamma_H$	–	8% [†]	tbd
HHv _e $\bar{\nu}_e$	$\sigma(\text{HHv}_e \bar{\nu}_e)$	g_{HHWW}	–	7%*	3%*
HHv _e $\bar{\nu}_e$	$\sigma(\text{HHv}_e \bar{\nu}_e)$	λ	–	28%	16%
HHv _e $\bar{\nu}_e$	with –80% e ⁻ polarization	λ	–	21%	12%

Table 9: Summary table of the CLIC SUSY benchmark analyses results obtained with full-detector simulations with background overlaid. All studies are performed at a center-of-mass energy of 3 TeV (1.4 TeV) and for an integrated luminosity of 2 ab^{-1} (1.5 ab^{-1}) [23, 24, 25, 26, 27, 28, 29].

\sqrt{s} (TeV)	Process	Decay mode	SUSY model	Measured quantity	Generator value (GeV)	Stat. uncertainty
3.0	Sleptons	$\tilde{\mu}_R^+ \tilde{\mu}_R^- \rightarrow \mu^+ \mu^- \tilde{\chi}_1^0 \tilde{\chi}_1^0$	II	$\tilde{\ell}$ mass	1010.8	0.6%
				$\tilde{\chi}_1^0$ mass	340.3	1.9%
		$\tilde{e}_R^+ \tilde{e}_R^- \rightarrow e^+ e^- \tilde{\chi}_1^0 \tilde{\chi}_1^0$		$\tilde{\ell}$ mass	1010.8	0.3%
				$\tilde{\chi}_1^0$ mass	340.3	1.0%
		$\tilde{\nu}_e \tilde{\nu}_e \rightarrow \tilde{\chi}_1^0 \tilde{\chi}_1^0 e^+ e^- W^+ W^-$		$\tilde{\ell}$ mass	1097.2	0.4%
				$\tilde{\chi}_1^\pm$ mass	643.2	0.6%
3.0	Chargino Neutralino	$\tilde{\chi}_1^+ \tilde{\chi}_1^- \rightarrow \tilde{\chi}_1^0 \tilde{\chi}_1^0 W^+ W^-$	II	$\tilde{\chi}_1^\pm$ mass	643.2	1.1%
		$\tilde{\chi}_2^0 \tilde{\chi}_2^0 \rightarrow h/Z^0 h/Z^0 \tilde{\chi}_1^0 \tilde{\chi}_1^0$		$\tilde{\chi}_2^0$ mass	643.1	1.5%
3.0	Squarks	$\tilde{q}_R \tilde{q}_R \rightarrow q \bar{q} \tilde{\chi}_1^0 \tilde{\chi}_1^0$	I	\tilde{q}_R mass	1123.7	0.52%
3.0	Heavy Higgs	$H^0 A^0 \rightarrow b \bar{b} b \bar{b}$	I	H^0/A^0 mass	902.4/902.6	0.3%
		$H^+ H^- \rightarrow t \bar{b} b \bar{t}$		H^\pm mass	906.3	0.3%
1.4	Sleptons	$\tilde{\mu}_R^+ \tilde{\mu}_R^- \rightarrow \mu^+ \mu^- \tilde{\chi}_1^0 \tilde{\chi}_1^0$	III	$\tilde{\ell}$ mass	560.8	0.1%
				$\tilde{\chi}_1^0$ mass	357.8	0.1%
		$\tilde{e}_R^+ \tilde{e}_R^- \rightarrow e^+ e^- \tilde{\chi}_1^0 \tilde{\chi}_1^0$		$\tilde{\ell}$ mass	558.1	0.1%
				$\tilde{\chi}_1^0$ mass	357.1	0.1%
		$\tilde{\nu}_e \tilde{\nu}_e \rightarrow \tilde{\chi}_1^0 \tilde{\chi}_1^0 e^+ e^- W^+ W^-$		$\tilde{\ell}$ mass	644.3	2.5%
				$\tilde{\chi}_1^\pm$ mass	487.6	2.7%
1.4	Stau	$\tilde{\tau}_1^+ \tilde{\tau}_1^- \rightarrow \tau^+ \tau^- \tilde{\chi}_1^0 \tilde{\chi}_1^0$	III	$\tilde{\tau}_1$ mass	517	2.0%
1.4	Chargino Neutralino	$\tilde{\chi}_1^+ \tilde{\chi}_1^- \rightarrow \tilde{\chi}_1^0 \tilde{\chi}_1^0 W^+ W^-$	III	$\tilde{\chi}_1^\pm$ mass	487	0.2%
		$\tilde{\chi}_2^0 \tilde{\chi}_2^0 \rightarrow h/Z^0 h/Z^0 \tilde{\chi}_1^0 \tilde{\chi}_1^0$		$\tilde{\chi}_2^0$ mass	487	0.1%