

Review of results on Standard Model from the ATLAS experiment



Mélissa Ridet (LPNHE)
on behalf of the ATLAS collaboration



Outline

Motivation for the Standard Model measurements and run I data taking

Selection of recent results:

- QCD:
 - inclusive jet and dijet production
 - running of α_s from multi jet cross section
 - inclusive jet production ratio
- Photons
 - inclusive photon cross section
 - isolated photon pair production
- Electroweak
 - High-mass Drell-Yan differential cross section
 - ZZ, WZ production and Triple Gauge Couplings
 - forward-backward asymmetry of Z/γ^*
- Standard Model summary

Conclusion

Where do we stand ?

Last year's discovery is probably the most important event in High Energy Physics in the last 30 years: will it be the triumph of the Standard Model or a gateway to new physics?

Consistency of the Standard Model: no pull value exceeds deviations of more than 3 sigma.

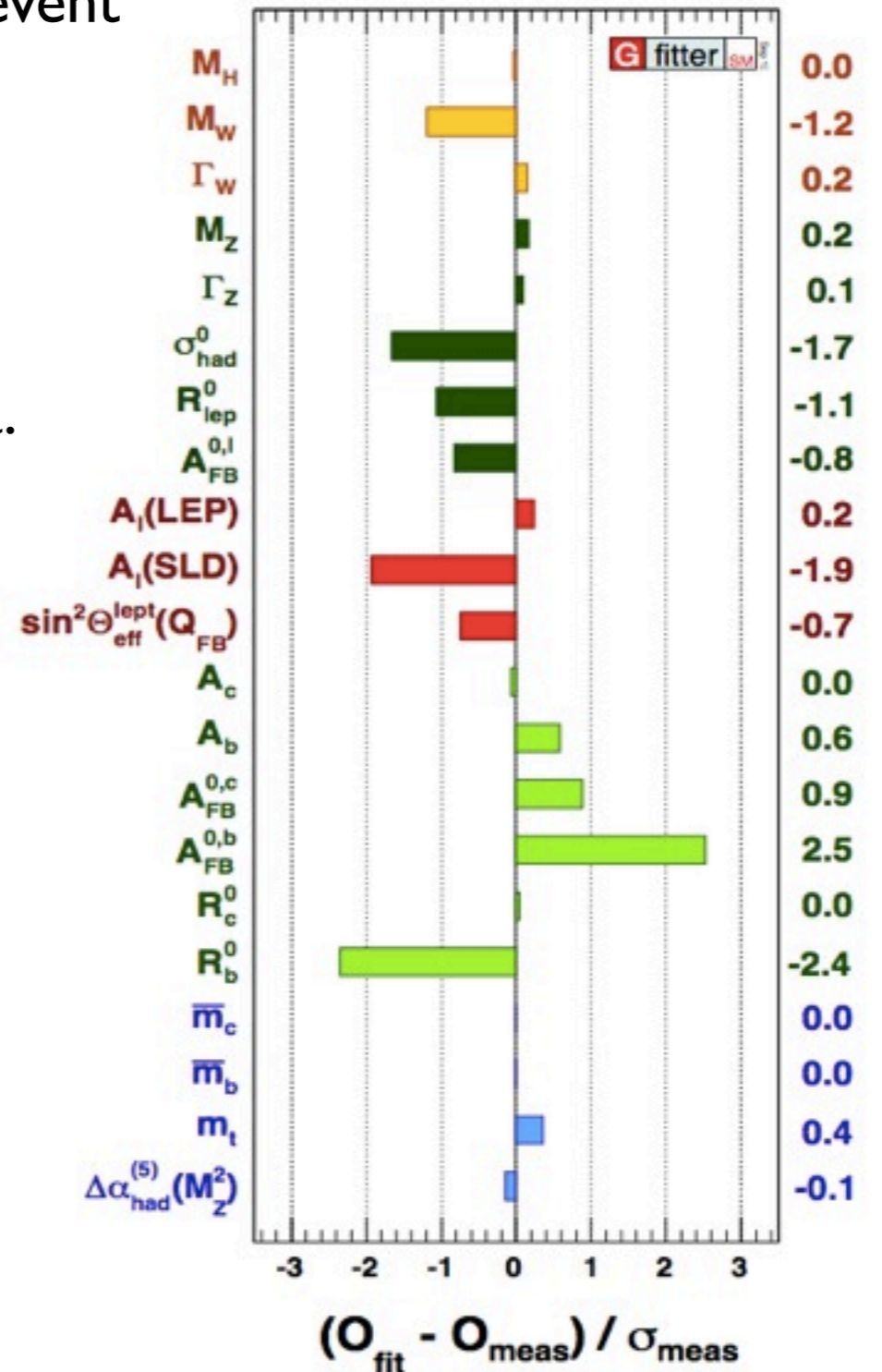
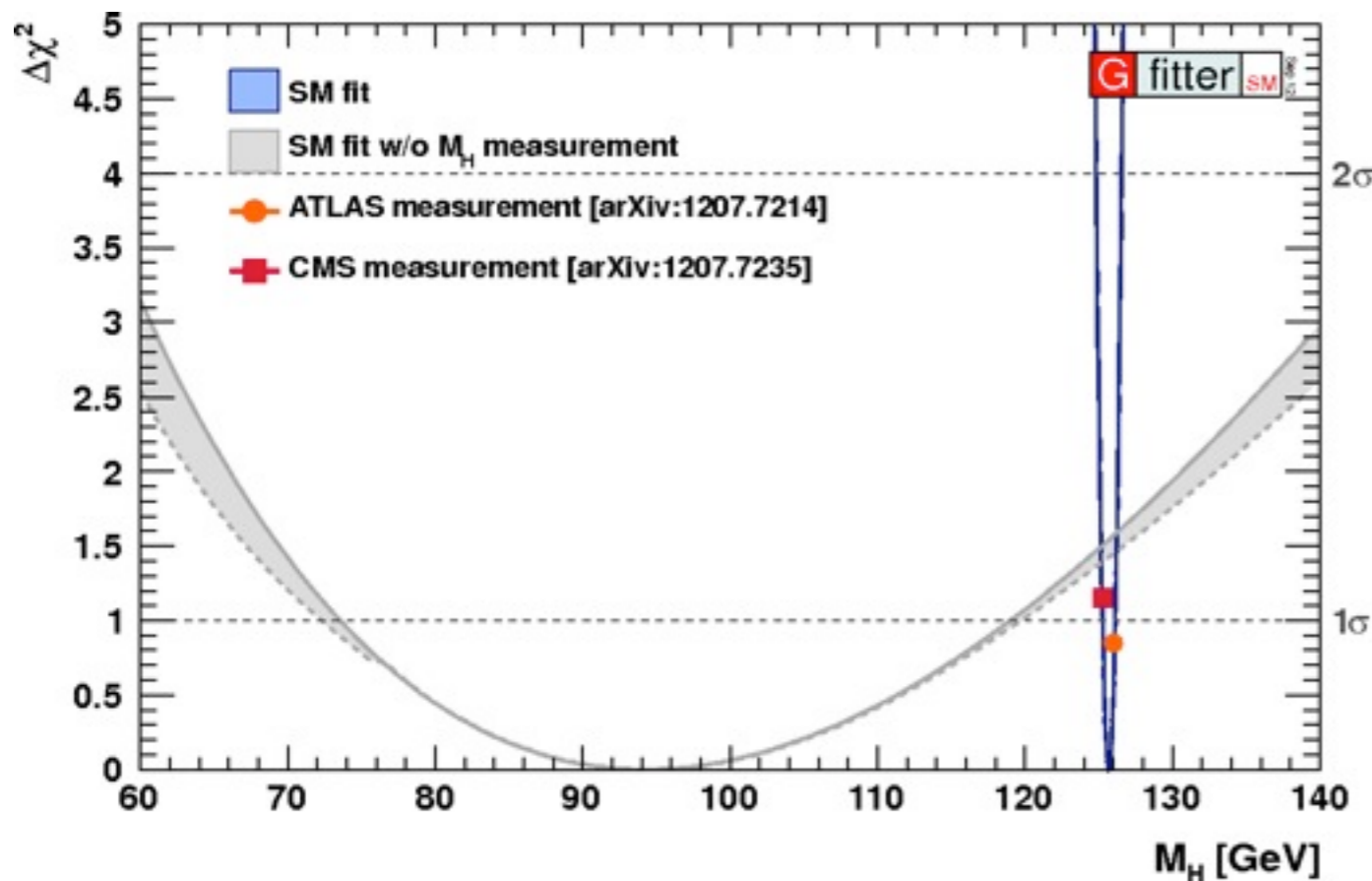

Standard Model: QCD, photon and electroweak

- Jets are abundant final states at LHC. We can learn about PDF's, α_s and perturbative and non perturbative QCD;
- cross section measurements for dibosons test the SM and probe new physics (triple gauge coupling for example);
- photons, jets and dibosons are important background to physics searches using other final states;
- Before searching for new Physics, let's check that the standard physics is well under control with Standard Model measurements which allow to:
 - validate the Standard Model in a **new energy** regime;
 - understand the **background** for other studies;
 - improve the **precision** of SM parameters;
 - constrain **new physics** contributions (like anomalous couplings).

Run I pp data taking

Excellent LHC and detectors performances.

Luminosity measured with forward detectors, calibrated with beam separation scans: uncertainty: 2.8 %

Delivered L in 2012 (pp): 23.3 fb^{-1}

Recorded L in 2012 (pp): 21.7 fb^{-1}

All detectors/triggers good for physics: 95.8 %

Total Efficiency $\sim 90 \%$ (delivered physics \rightarrow analysis)

Atlas has been able to handle the pile-up challenge thanks to fast triggers, optimized reconstruction of objects, precise modeling of pile up in MC and improvement in computing models to handle the rate.

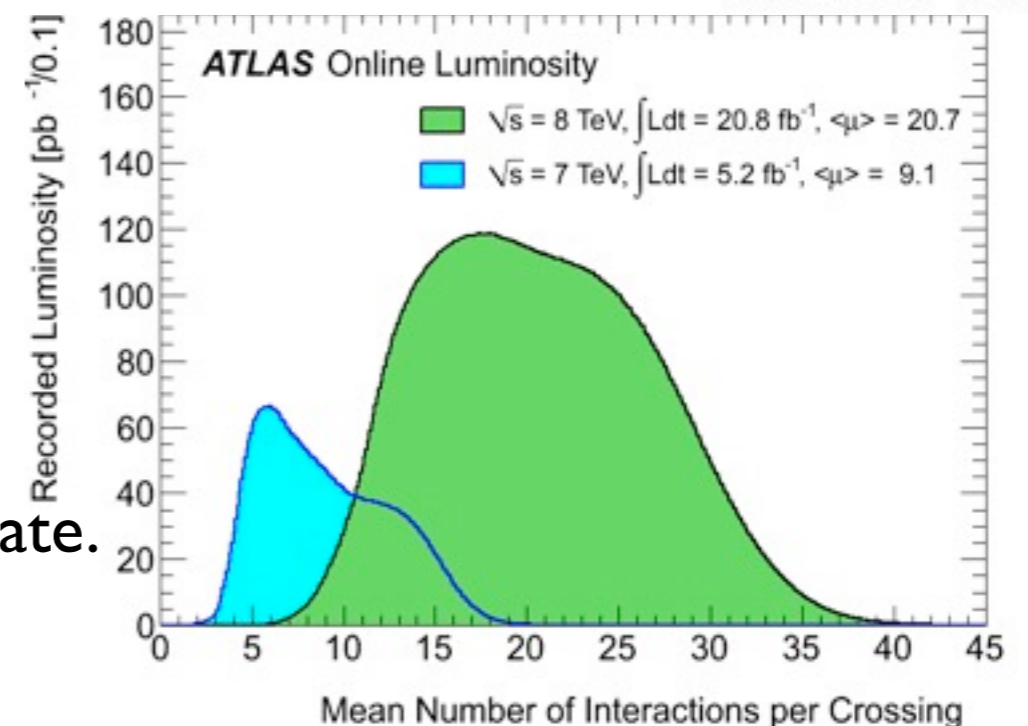
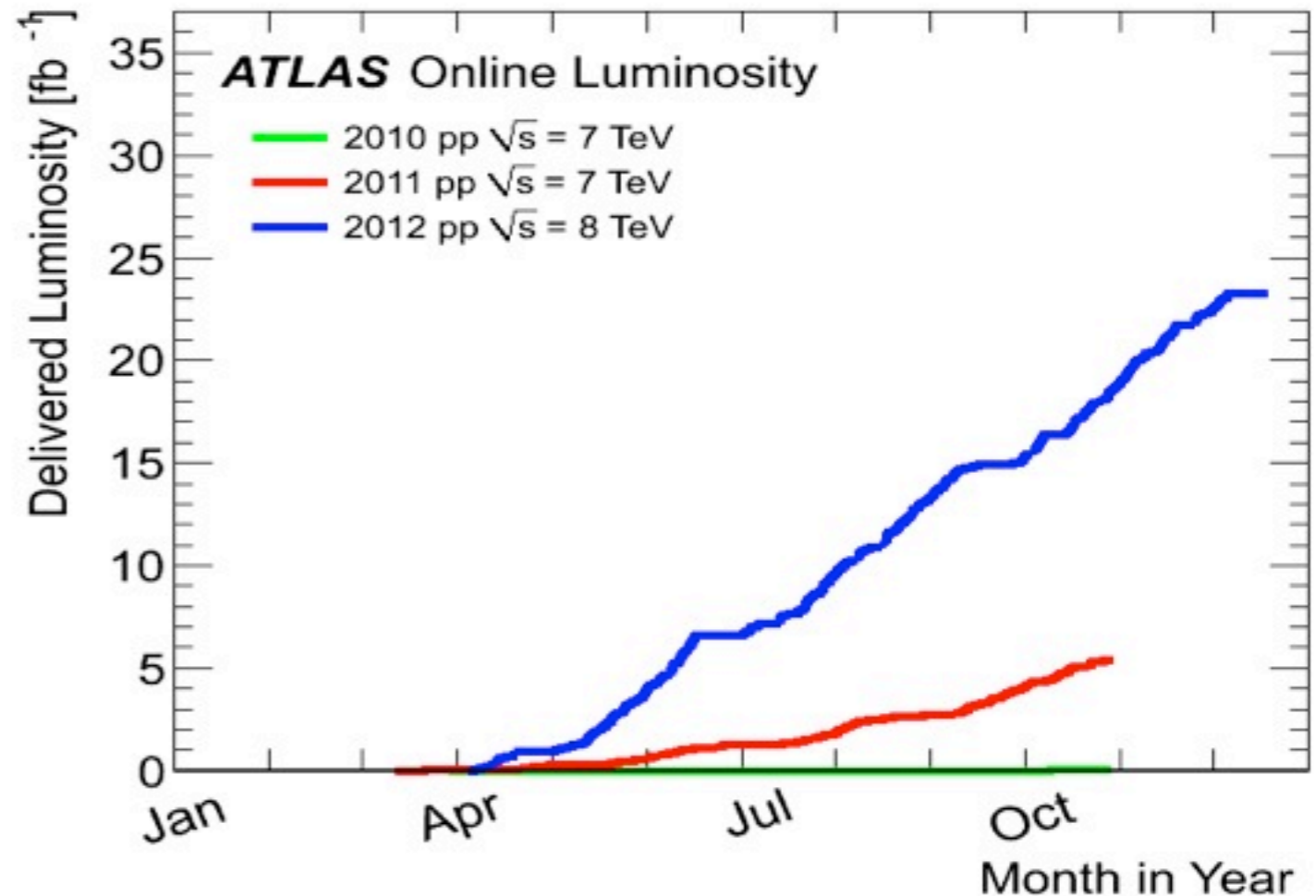

Inclusive jet and dijet production cross sections

Phys.Rev. D86 (2012) 014022

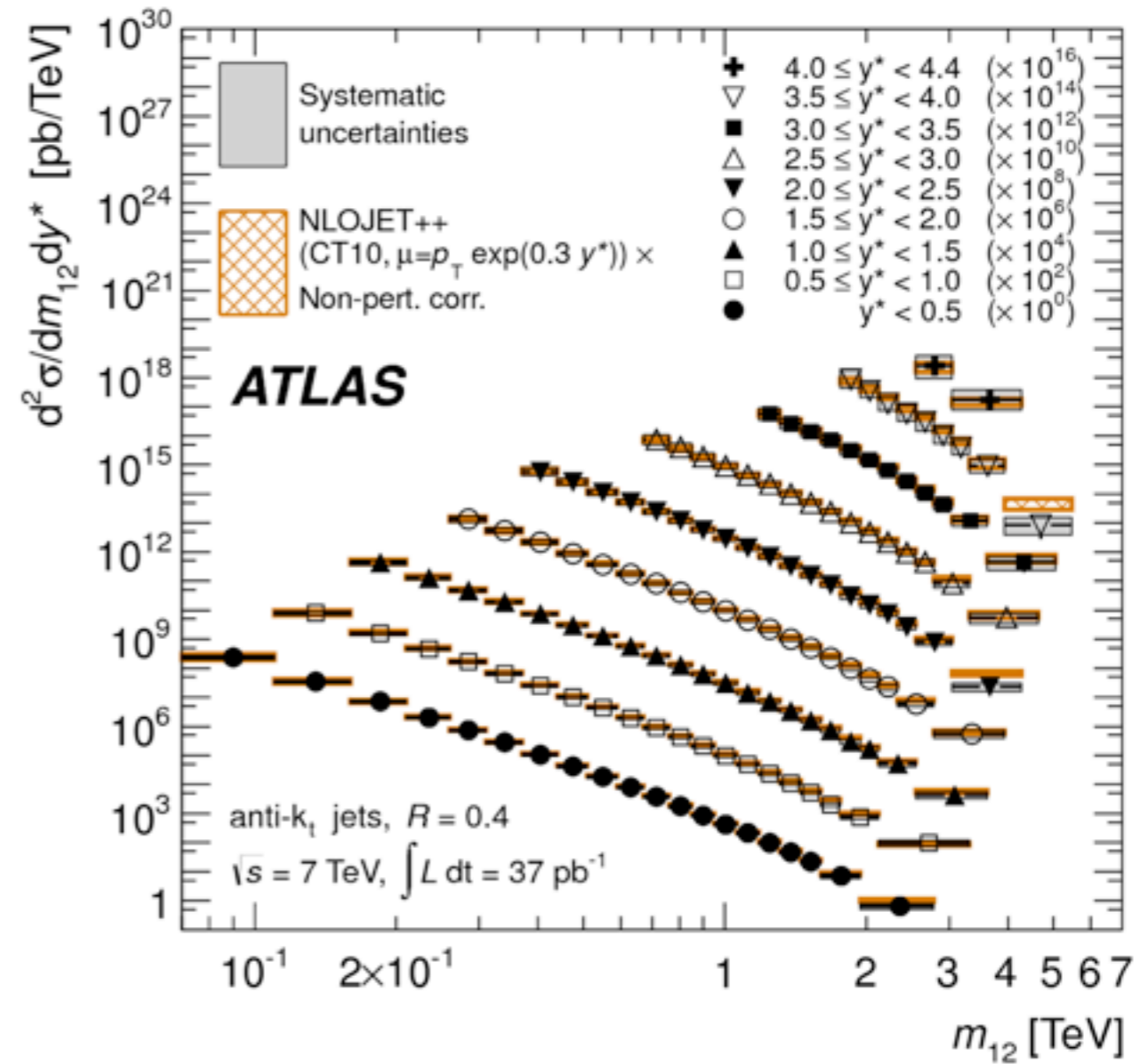
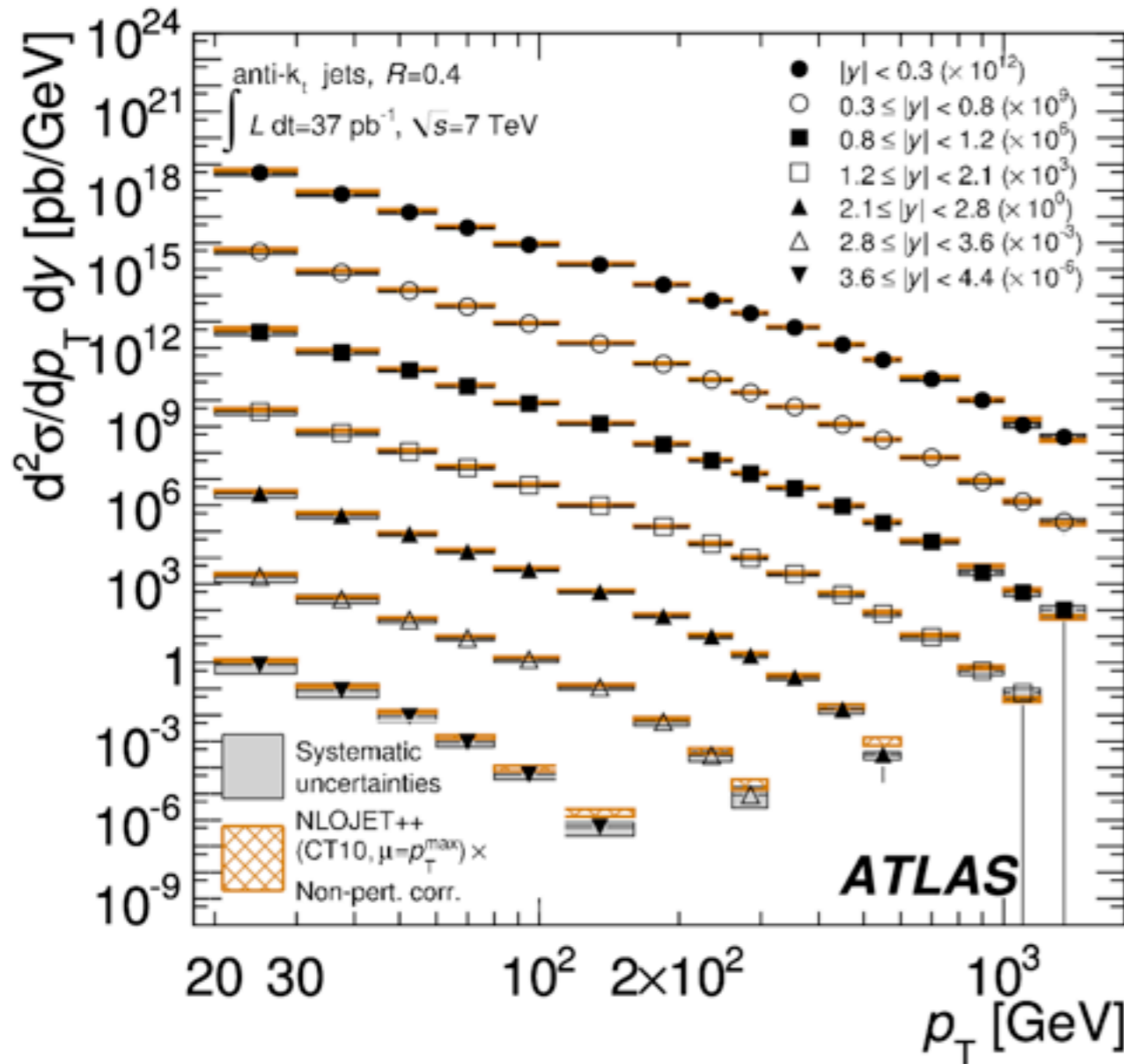

All measurements are done with anti K_T with $R=0.4$ and 0.6 .

General agreement with NLO QCD calculations over many orders of magnitude up to 2 TeV in jet P_T .

Both double differential cross sections are proportional to α_s^2 (see next analysis).

Running of α_s from multi jet cross section

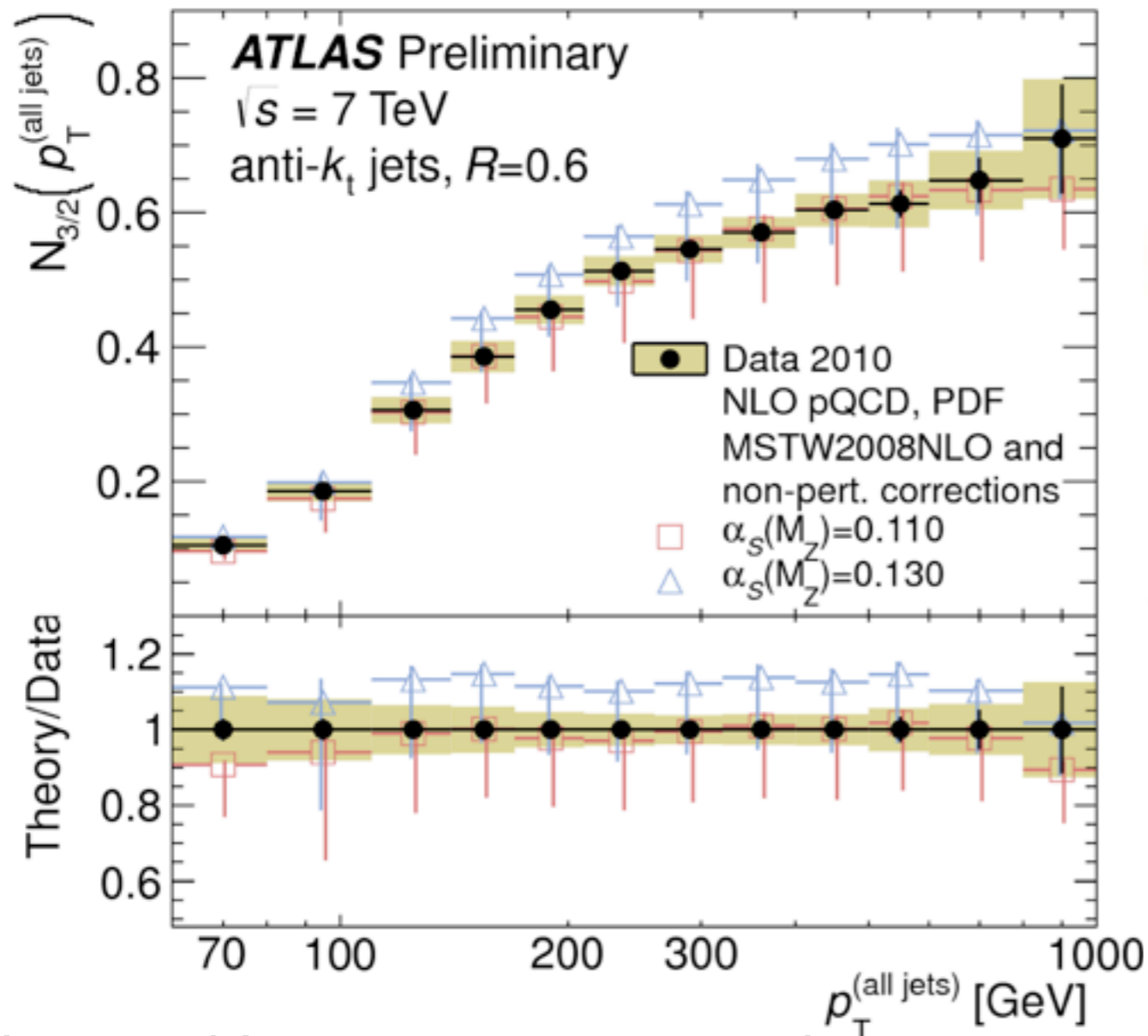

ATLAS-CONF-2013-041

$$N_{3/2}(p_T^{(\text{all jets})}) = \frac{\sum_i^{N_{\text{jet}}} (d\sigma_{N_{\text{jet}} \geq 3} / dp_{T,i})}{\sum_i^{N_{\text{jet}}} (d\sigma_{N_{\text{jet}} \geq 2} / dp_{T,i})}$$

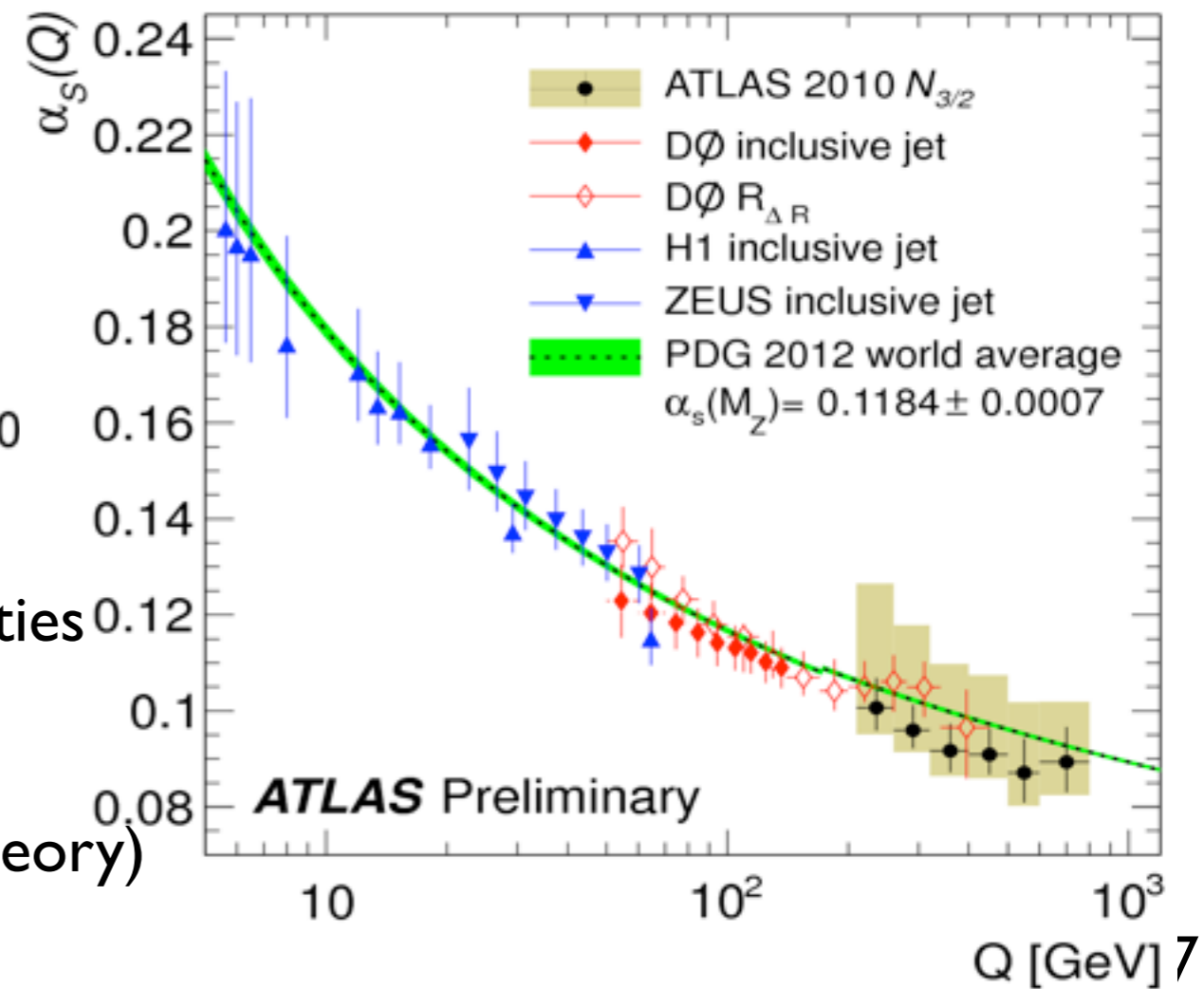

The ratio $N_{3/2}$ is sensitive to α_s and mostly insensitive to experimental systematic uncertainties

- avoids direct dependency on PDFs
- eliminates dependency on lumi normalization

$$\alpha_s^{\text{ATLAS}}(M_Z) = 0.111 \pm 0.006 (\text{exp})^{+0.016}_{-0.003} (\text{theory})$$

Inclusive jet production ratio (1/2)

Ratio of inclusive jet P_t spectra cross sections at 2 different energies:
2.76 TeV (2011) and 7.0 TeV (2010)

EPJC (2013) 73 2509

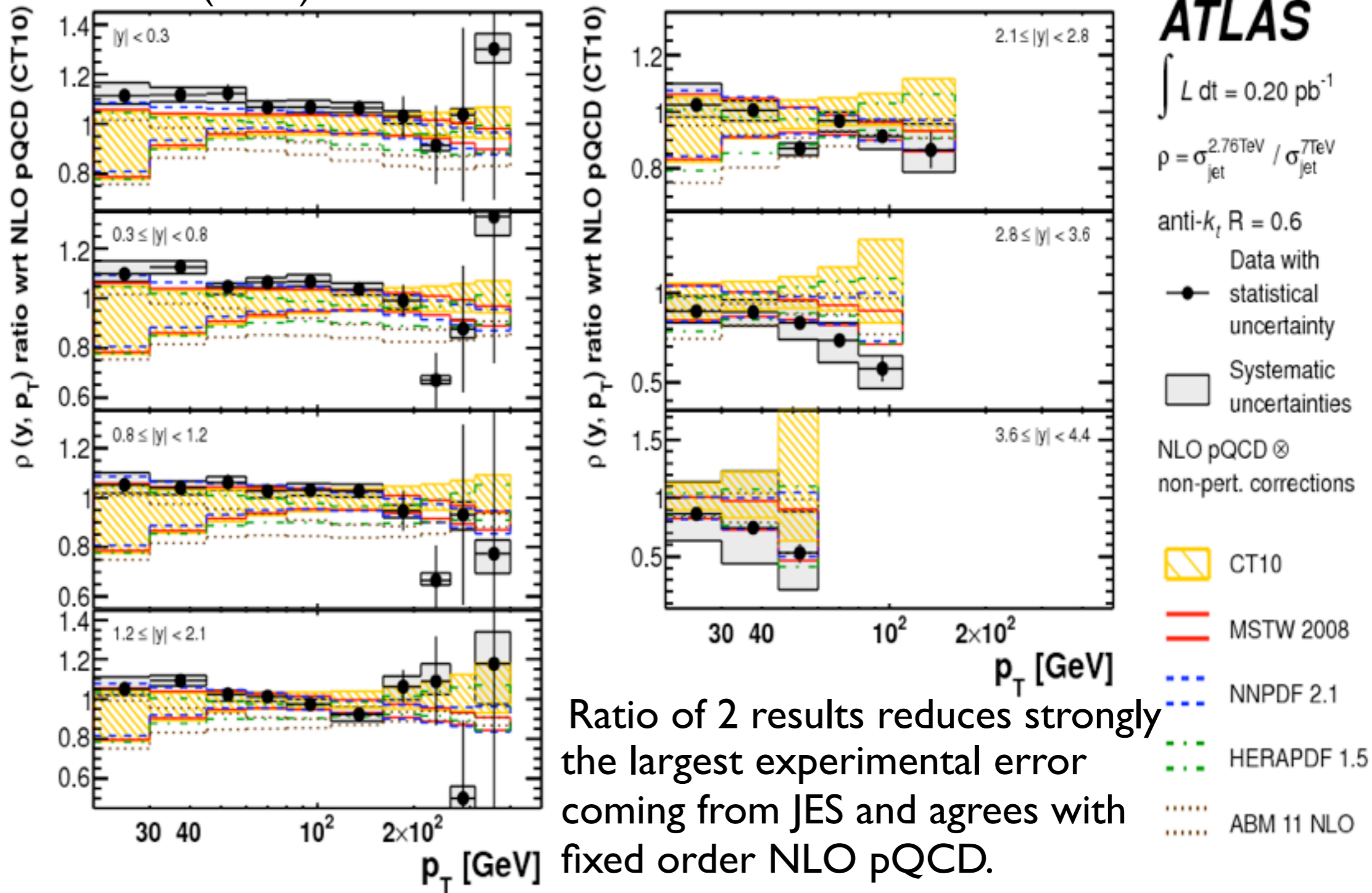

Ratio of 2 results reduces strongly the largest experimental error coming from JES and agrees with fixed order NLO pQCD.

pQCD can describe jet prod. at high P_t . Ratio starts to show preference for certain PDF sets.

Inclusive jet production ratio (2/2)

Two different beam energies probe different x and Q^2 values for the same p_t and y ranges

→ theoretical uncertainties due to PDFs not cancelling in the ratio: extra sensitivity.

Gluon momentum distribution tends to become harder with ATLAS jet data included.

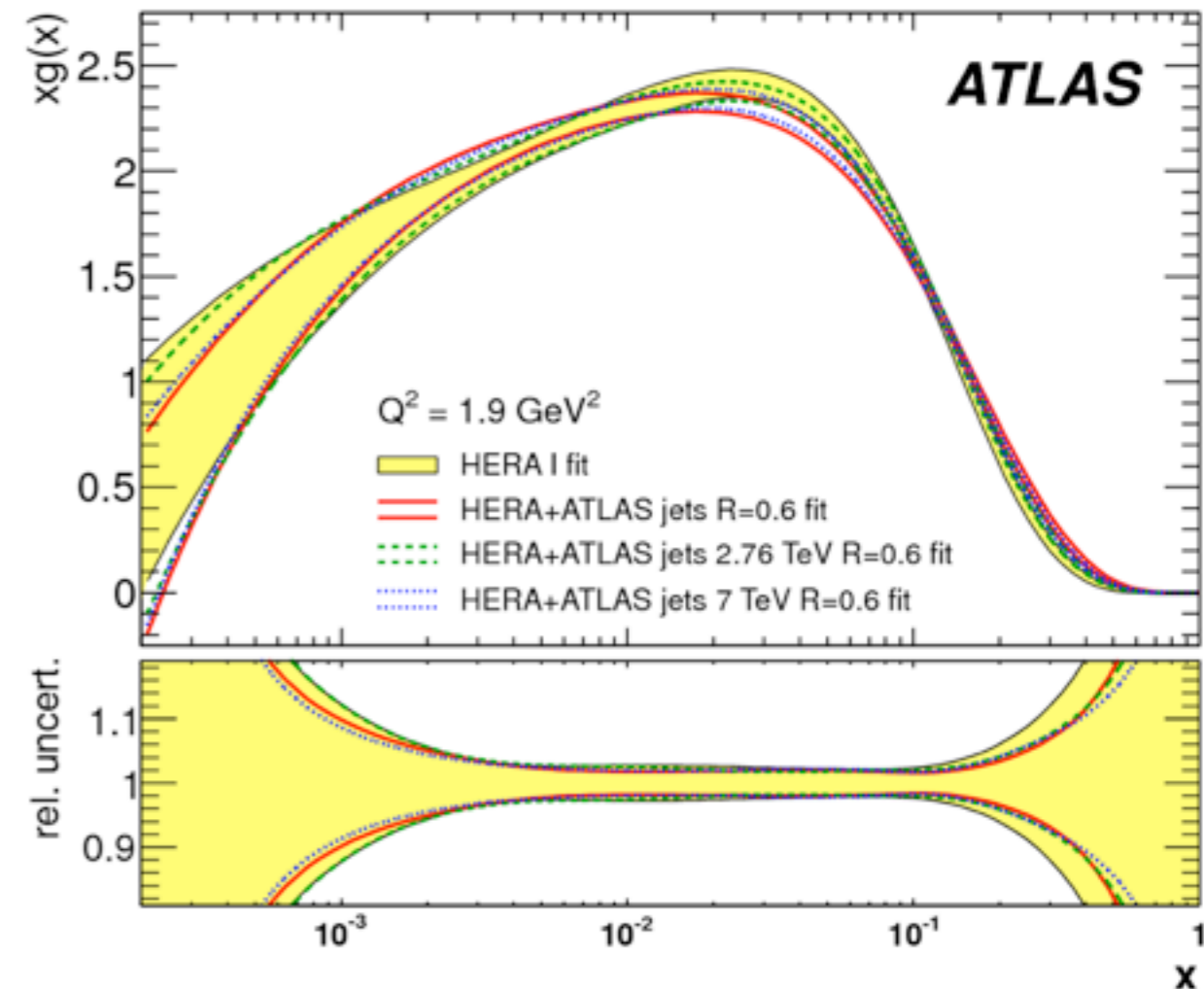

EPJC (2013) 73 2509

Inclusive cross section of isolated prompt photons

- Motivation: constrain PDFs (main production at the LHC $qg \rightarrow q\gamma$)
- QCD jet production is orders of magnitudes above the signal: jet rejection uses shower shape and isolation ($\Delta R < 0.4$) criteria
 - Signal extraction largely data-driven:
 - Signal pdf taken from MC, corrected using electron samples
 - Background pdf from data (with reverse identification, or isolation)
- 1 TeV region reached for $|\eta| < 1.37$
- Pythia in good agreement with data, Herwig is lower, but within error bars. Highest disagreement at low E_T .
- data are consistent with NLO, there are no disagreements given uncertainties.

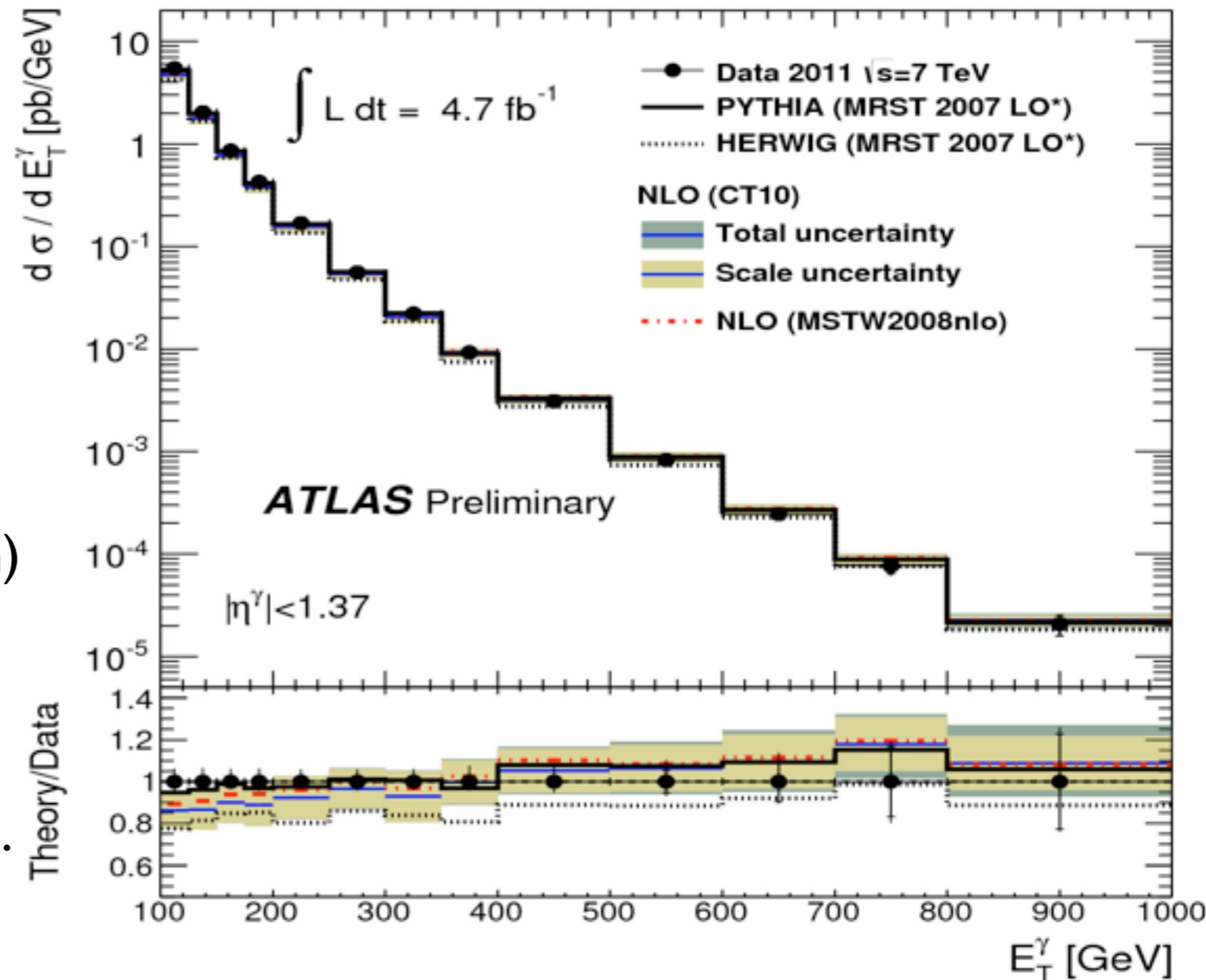

ATLAS-CONF-2013-022

Isolated photon pair production

Motivation: background for $H \rightarrow \gamma\gamma$ and QCD test

Signal extraction: 2 methods to subtract the jet background (jet-jet and γ -jet events)

- 2D Template Fit with leakage correction
- 2x2D Sideband, extended with jj isolation correlation
- 2 isolated photons $E_t > 25, 22$ GeV separated by $\Delta R > 0.4$
- di-photon trigger efficiency $\sim 98\%$

Th. uncertainties: dominated by scale error and then PDFs (large fragmentation contribution at low mass):

$$\sigma_{\text{ATLAS}} = 44.0 \text{ pb}^{+3.2}_{-4.2}$$

$$\text{LO} \rightarrow 36 \text{ pb (20\%)}$$

$$2\gamma \text{ NNLO} \rightarrow 44^{+6}_{-5} \text{ pb : excellent agreement}$$

JHEP01(2013)086

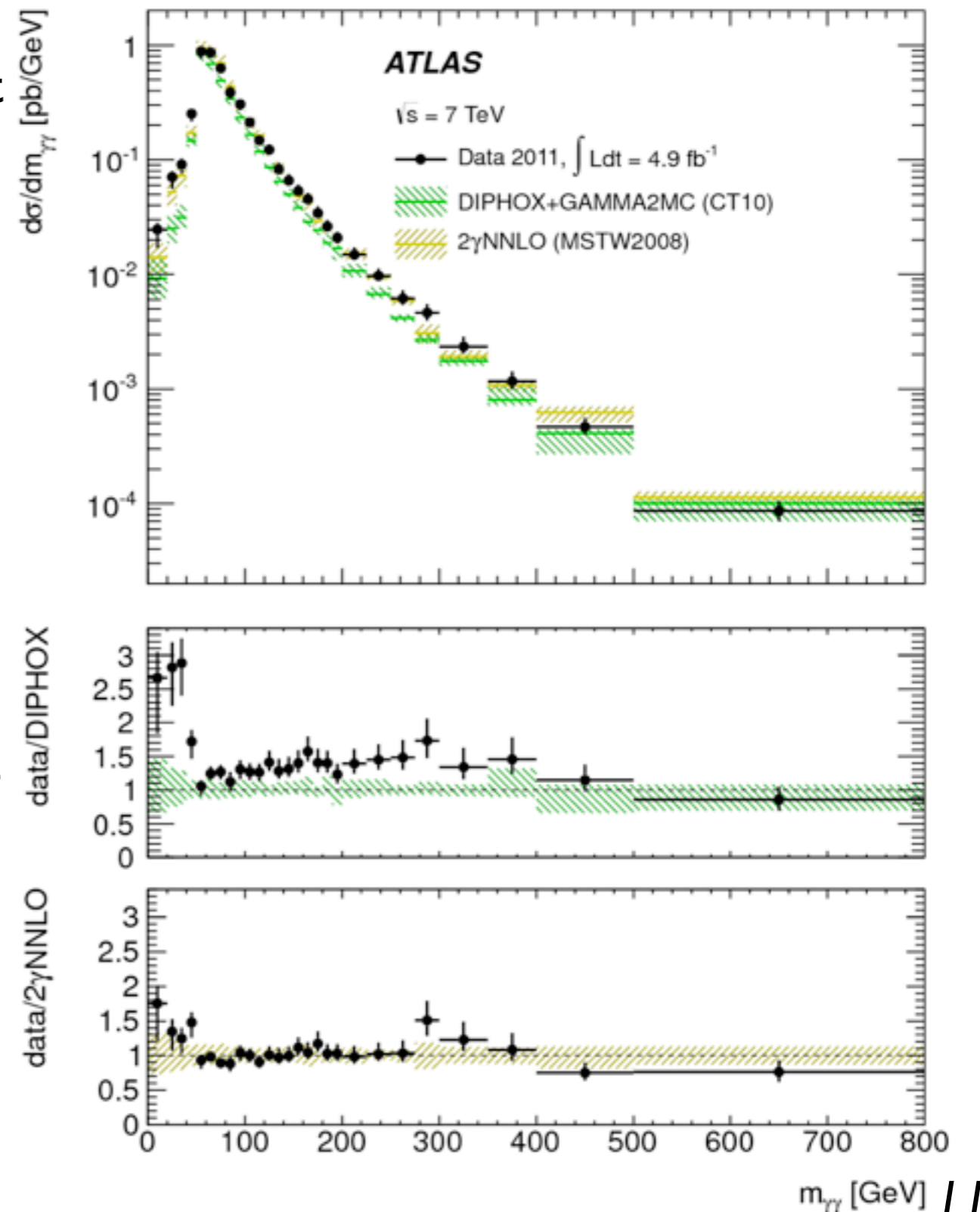

High-mass Drell-Yan differential cross section

arXiv:1305.4192

In addition to inclusive W and Z cross sections (not shown here), ATLAS measured differential cross sections including in the regions far away from the Z pole:

- pQCD test
- sensitive to PDFs

Electrons with $P_t > 25$ GeV and $|\eta| < 2.5$. Low background, small experimental uncertainty expected.

Predictions based on NNLO QCD calculations including NLO EW corrections, shown for different NLO PDF sets, compatible with data for 5 PDF sets.

Potential to constrain antiquark PDFs at large x.

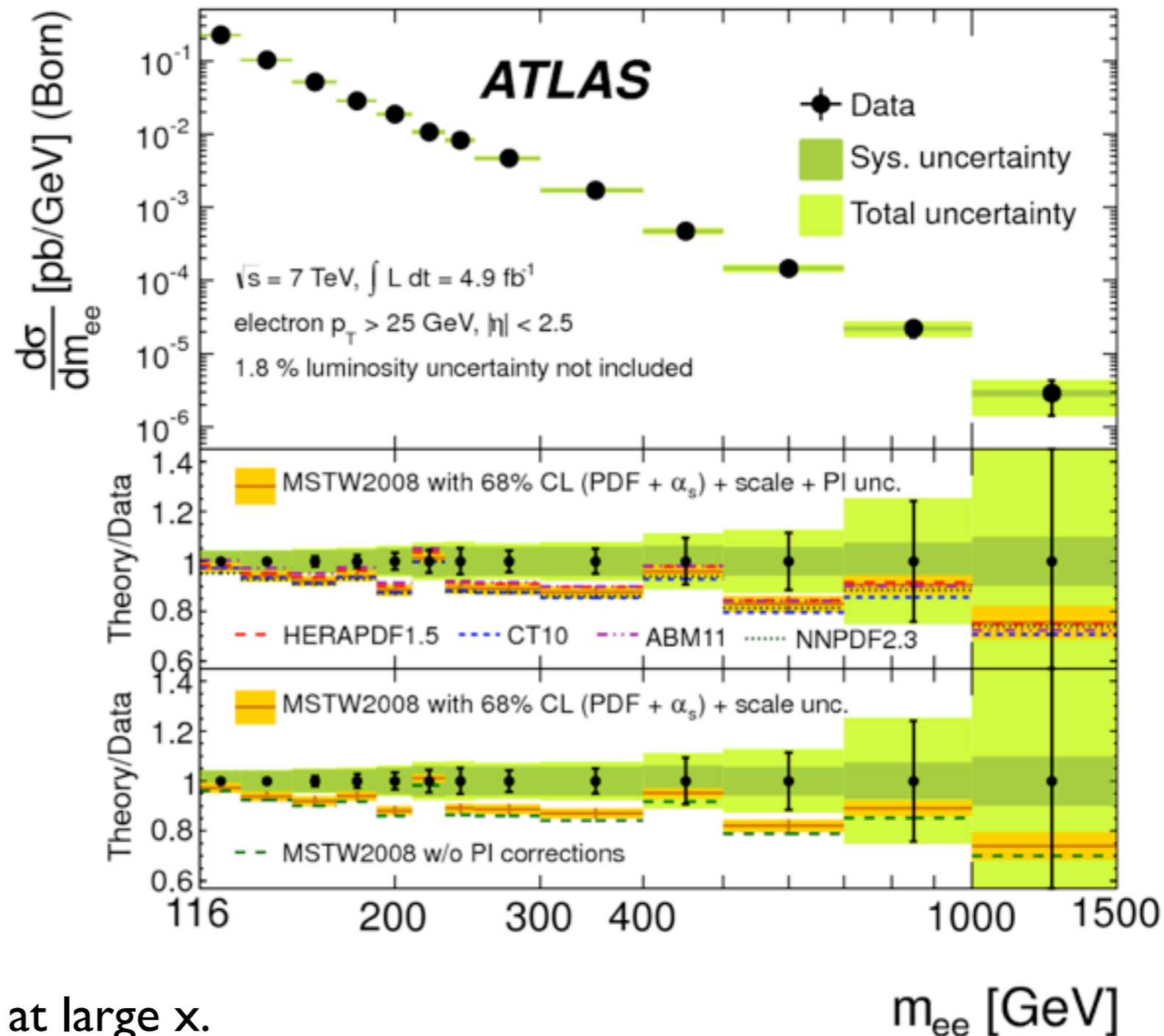

Forward-backward asymmetry of Z/γ^*

ATLAS-CONF-2013-043

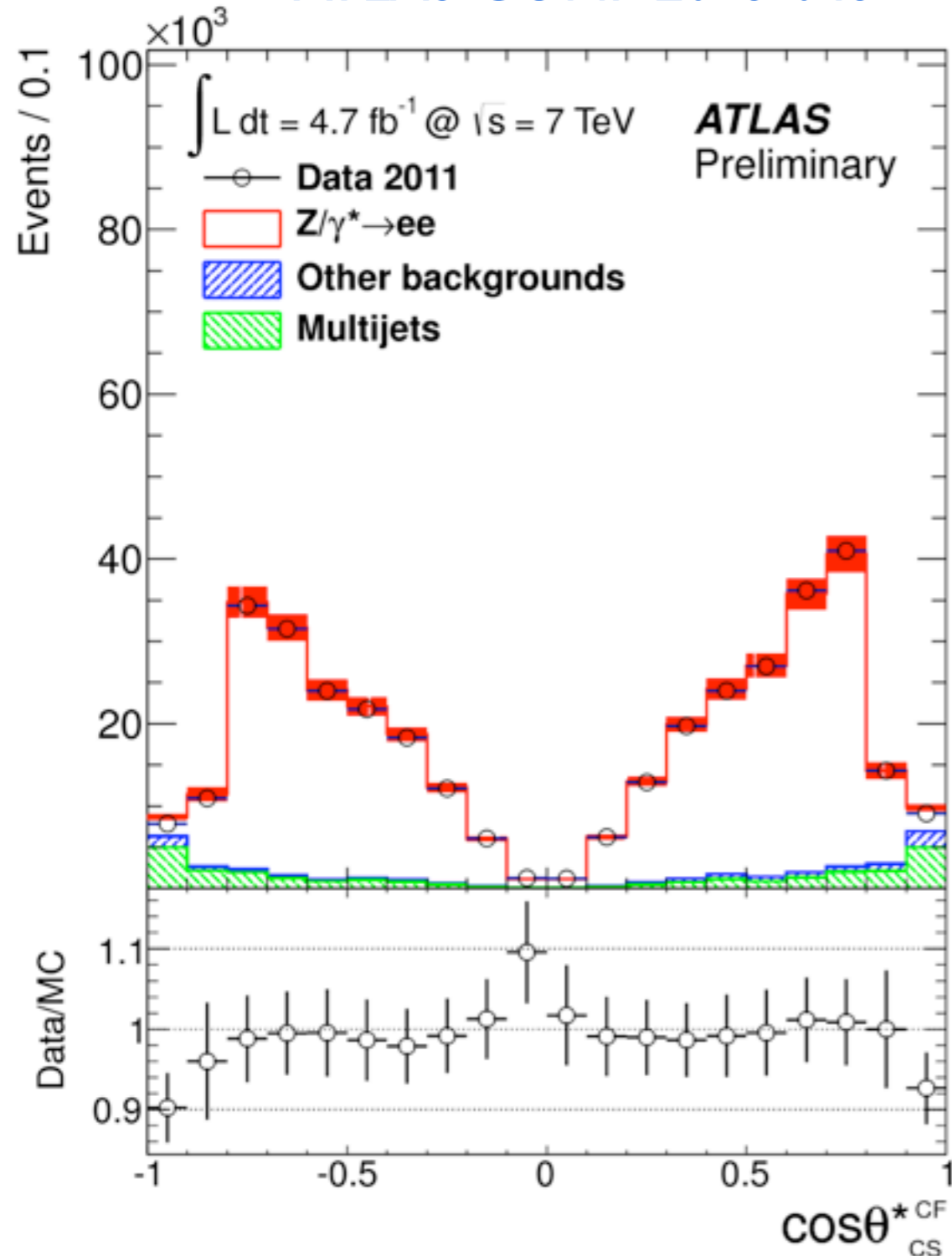

Lepton pairs from Z/γ^* decays.
 Use asymmetry ($A_{FB} = \frac{\sigma_F - \sigma_B}{\sigma_F + \sigma_B}$) to determine the effective weak mixing angle:

$$\sin^2 \theta_W^{\text{eff}} = 0.2297 \pm 0.0004(\text{stat}) \pm 0.0009(\text{syst})$$

Consistent with previous measurements.

Precision comparable with Tevatron.

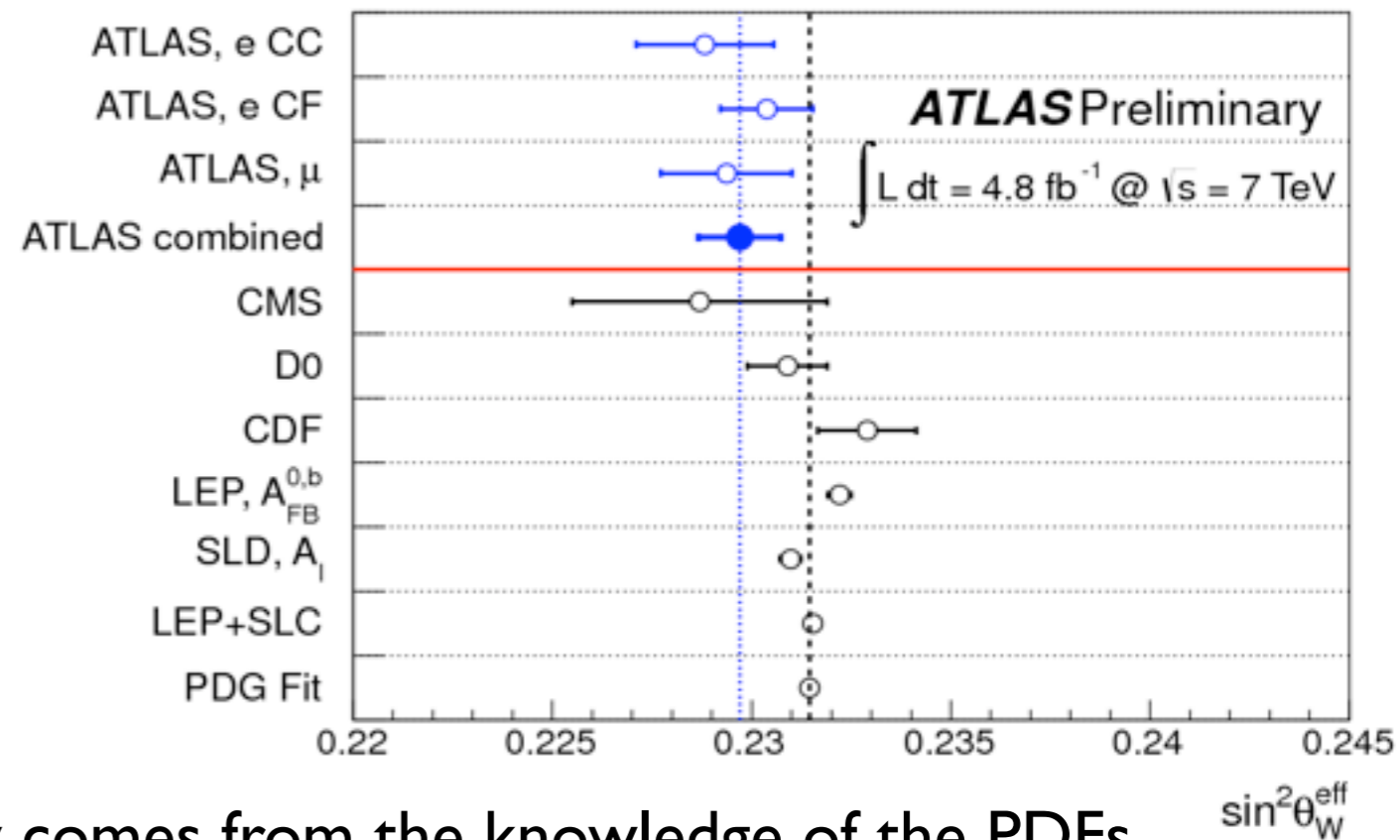

The dominant uncertainty comes from the knowledge of the PDFs.

Diboson physics

Importance of di-boson production:

significant and irreducible background for Higgs and exotica searches:

for $m_H = 125 \text{ GeV}$, $H \rightarrow VV$ is 25%

Dibosons sensitive to Triple Gauge Couplings.

Deviations could indicate physics beyond SM, as neutral TGC.

- WWg and WWZ are allowed
- ZZg , $Z\gamma\gamma$ and ZZZ are forbidden

ZZ example: some leading order Feynman diagrams for ZZ production through qqbar and gg initial states

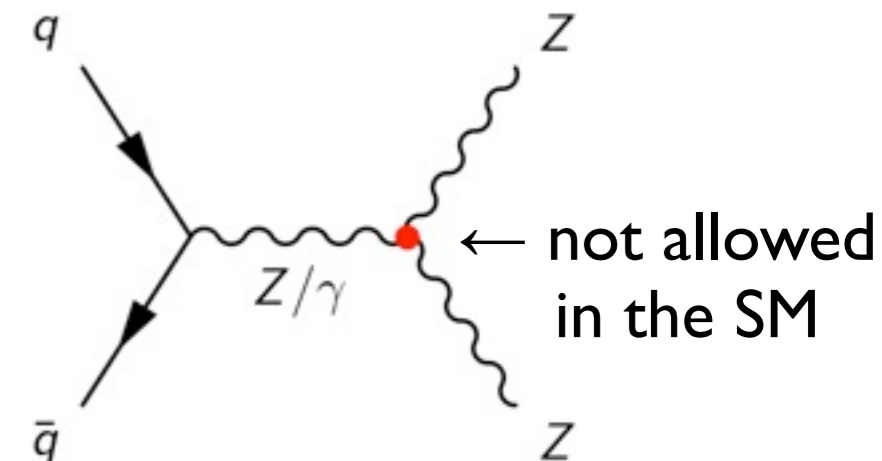
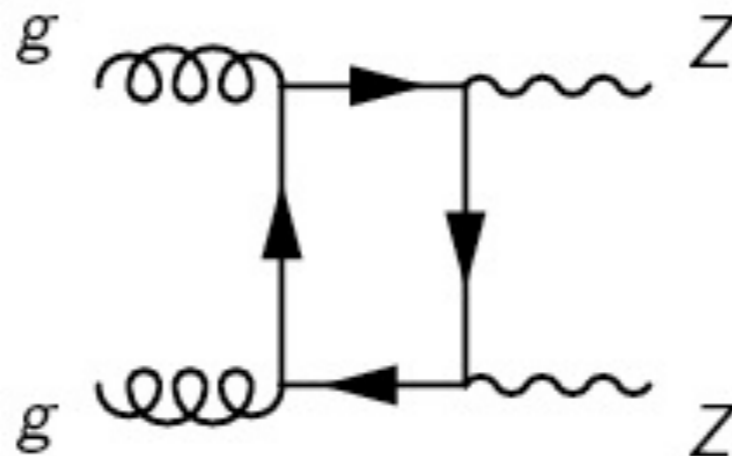
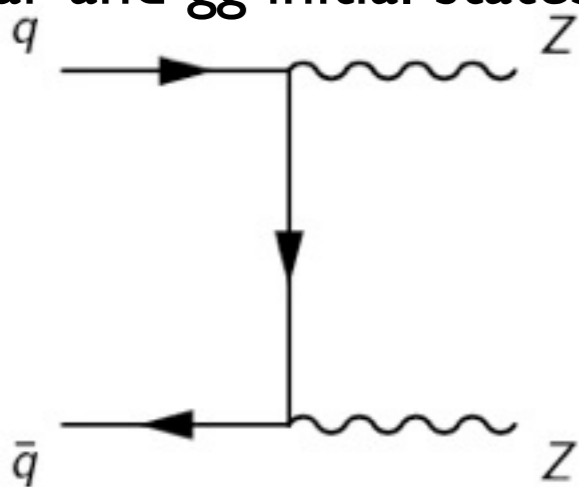

no contribution at tree level
and at one loop,
effective coupling at 10^{-4} level

ZZ, WZ production and Triple Gauge Couplings

$$\sigma(pp \rightarrow ZZ) = 7.1_{-0.4}^{+0.5}(\text{stat}) \pm 0.3(\text{sys}) \pm 0.2(\text{lum}) \text{ pb}$$

ATLAS-CONF-2013-020

Total ZZ and WZ production cross sections: good agreement with NLO QCD

Charged and neutral TGC: in agreement with the SM.

For WWZ and WW γ , limits compatible or tighter than Tevatron for anomalous TGC, limits tighter than LEP and Tevatron.

ATLAS-CONF-2013-021

$$\sigma(pp \rightarrow WZ) = 20.3_{-0.7}^{+0.8}(\text{stat})_{-1.1}^{+1.2}(\text{sys})_{-0.6}^{+0.7}(\text{lum}) \text{ pb}$$

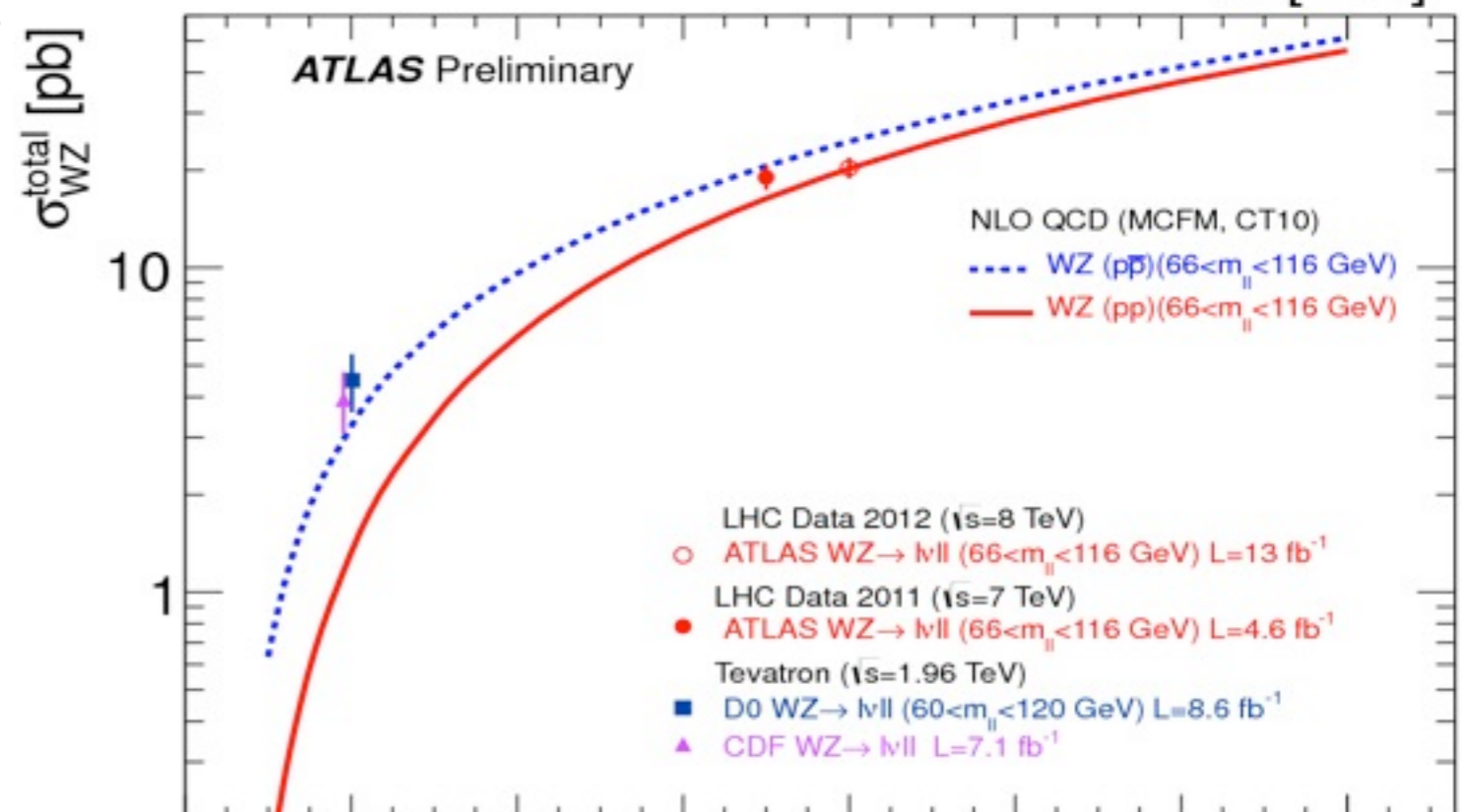
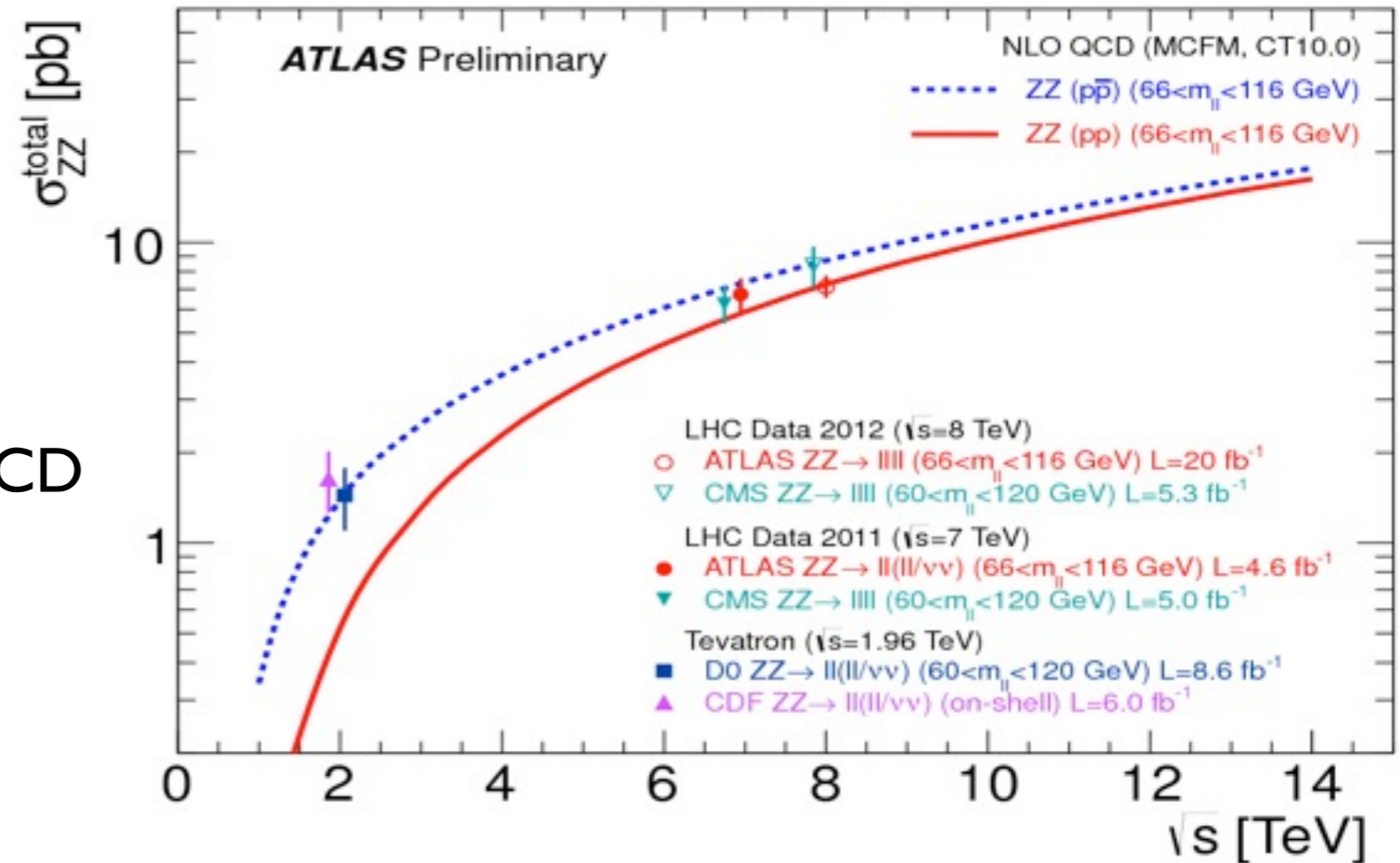

Standard Model summary

Extensive studies of inclusive and diboson cross sections are available. Only a few examples have been shown before.

SM processes well understood over many orders of magnitude.

All those measurements were key elements for the discovery of the Higgs boson.

Experimental precision in data starts to challenge theoretical uncertainty.

Largest improvements from theory:

- ✓ New NLO and NNLO calculations
- ✓ NLO with showering

Also improved G4 simulations and tuning of event generators.

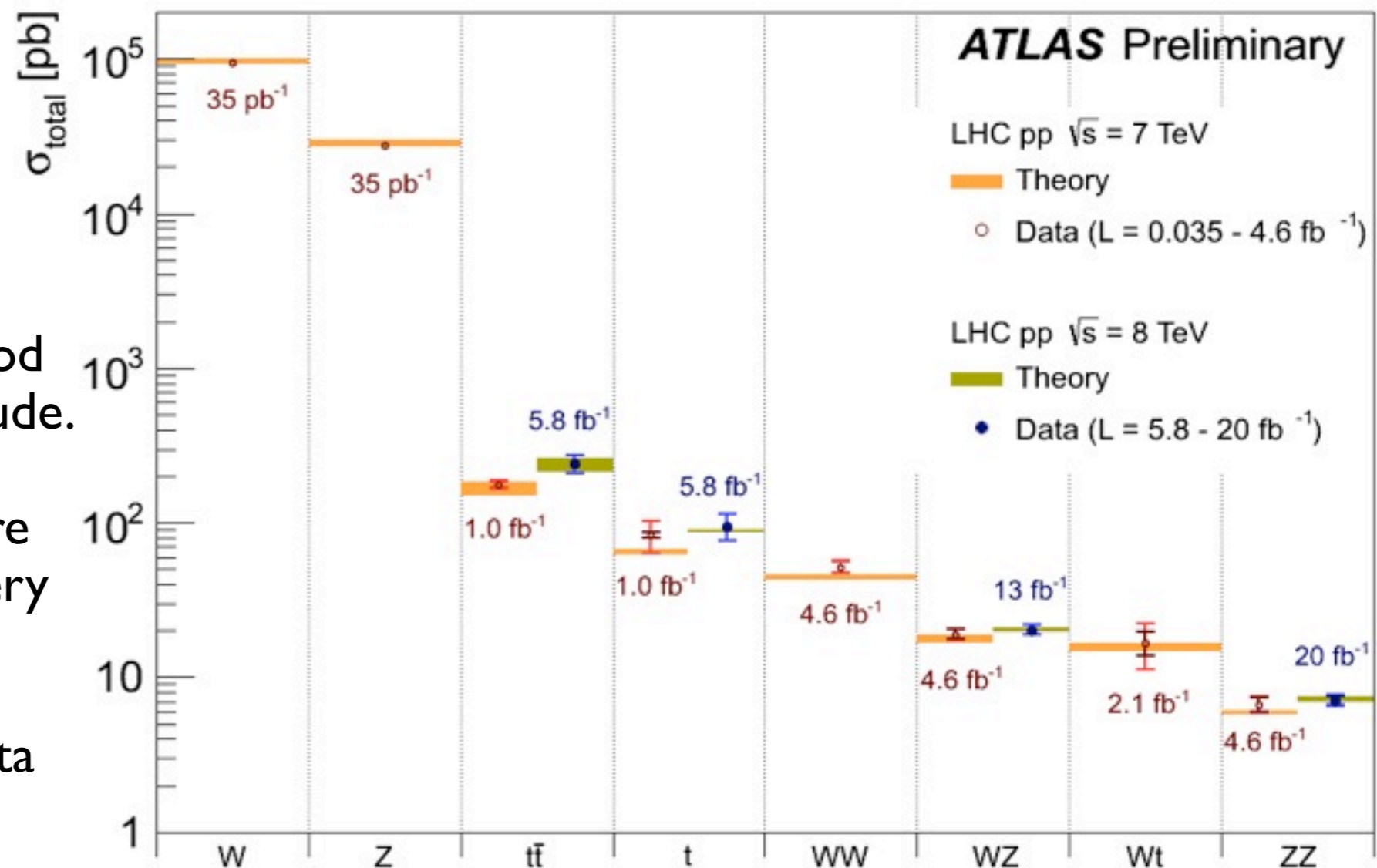

Conclusions

Superb performance of LHC accelerator and very fruitful times for the ATLAS collaboration:

- very good detector performance;
- high efficiency of data taking, computing and physics analysis.

Large statistics of the LHC sample allows to perform more detailed standard model measurements and already new measurements are probing observables at unprecedented level of accuracy and in never before exploited phase space regions.

Excellent agreement data/MC and cross section measurements in very good agreement with approx. NNLO calculations and in many cases, the systematics are becoming limiting: we are entering the era of precision measurements at the LHC.

Better understanding of QCD through differential measurements. Up to now, all the data are consistent with Standard Model.

Only a subset of ATLAS results have been shown here, please have a look at the experiment public page for a full list of the standard model publications.

LHC and ATLAS are taking a short break until 2015 to come back at 14TeV at the new energy frontier giving new results and hopefully surprises.