

church “**Domine Quo Vadis?**”
(Roma, via Appia Antica)

Higgs Quo Vadis?

Report back from the European
Strategy: the physics case for the
upgrade of ATLAS and CMS

Aleandro Nisati, INFN – Roma

Aspen - March 10th-15th, 2013

outline

- Physics at the Large Hadron Collider
- Latest results from ATLAS and CMS on the new Higgs-like particle
- Priorities after the discovery of the new boson
- “European Strategy”: the LHC Upgrade plan
- Physics at the HL-LHC
- Higgs boson physics at the HL-LHC
- Vector Boson Scattering at HL-LHC
- Beyond Standard Model searches

Physics at the Large Hadron Collider

- The LHC operations at high-energy started in 2010
- Excellent performance of the machine and of the four main experiments on the ring
- Collected in 2011 + 2012 about 5.5 fb^{-1} ($\sqrt{s} = 7 \text{ TeV}$) + 22 fb^{-1} ($\sqrt{s} = 8 \text{ TeV}$) by ATLAS and CMS
- A lot of solid outstanding experimental results are available:
 - agreement between Standard Model (SM) and data in the EW and QCD sectors
 - Discovery of a new particle, SM Higgs boson candidate, with mass around 125 GeV
 - Exclusion of a wide range of parameters values in Supersymmetry (SUSY) models
 - Exclusion of new heavy objects with mass up to 2-3 TeV

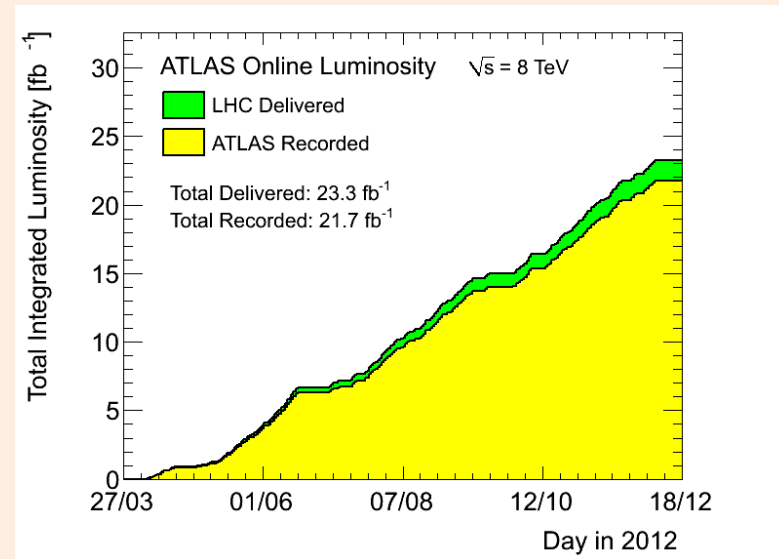

See Overview from Marjorie Shapiro and Guenther Dissertori

The successful Standard Model

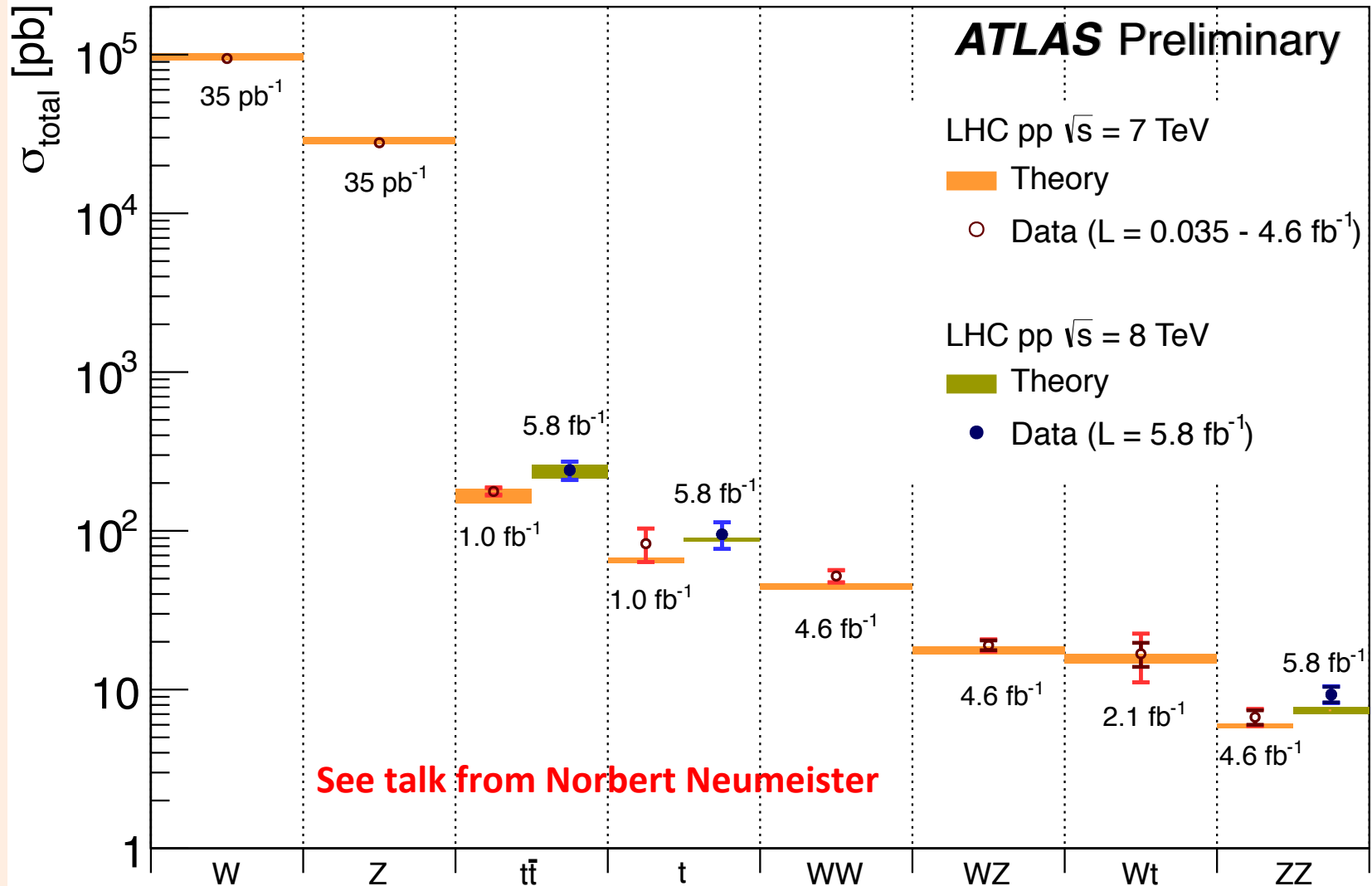

The Standard Model predictions are confirmed by experimental data within uncertainties



PHYSICS LETTERS B

Available online at www.sciencedirect.com
 SciVerse ScienceDirect

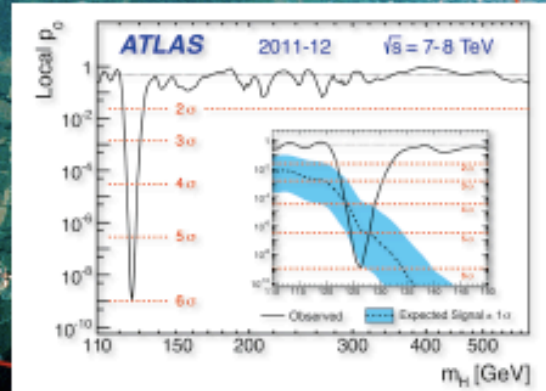
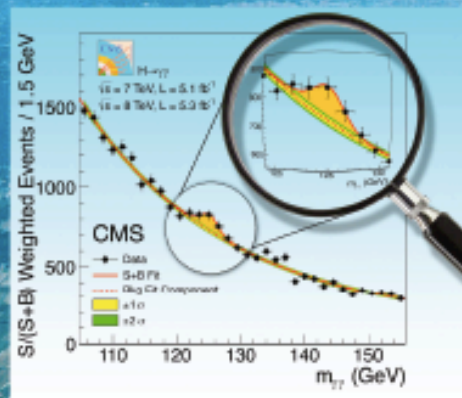

ATLAS

[Physics Letters B](#)

[Volume 716, Issue 1](#), 17

September 2012, Pages 1–29

Results based on:

- 4.8 fb⁻¹ of data at $\sqrt{s} = 7$ TeV
- 5.9 fb⁻¹ of data at $\sqrt{s} = 8$ TeV

CMS

[Physics Letters B](#)

[Volume 716, Issue 1](#), 17

September 2012, Pages 30–61

Results based on:

- 5.1 fb⁻¹ of data at $\sqrt{s} = 7$ TeV
- 5.3 fb⁻¹ of data at $\sqrt{s} = 8$ TeV

Main Results from ATLAS and CMS, end of 2012

- Since ICHEP 2012, ATLAS has presented three new results:
 - Update of $H \rightarrow \gamma\gamma$ with 13 fb^{-1} data (including the 4.8 fb^{-1} of 7 TeV data)
 - Update of $H \rightarrow ZZ(*) \rightarrow 4\text{-leptons}$ with 13 fb^{-1} data (including the 4.6 fb^{-1} of 7 TeV data)
 - Update of $H \rightarrow WW(*) \rightarrow l\nu l\nu$ with 13 fb^{-1} data
 - Update of $VH, H \rightarrow b\bar{b}$ with 13 fb^{-1} data (including the 4.6 fb^{-1} of 7 TeV data)
 - Update of $H \rightarrow \tau\tau$ with 13 fb^{-1} data (including the 4.6 fb^{-1} of 7 TeV data)
 - Update of the Higgs boson combination and physics properties using the latest results from $H \rightarrow \gamma\gamma$ and $H \rightarrow ZZ* \rightarrow 4\text{-leptons}$
- Since ICHEP 2012, CMS has presented new result on
 - $H \rightarrow ZZ(*) \rightarrow 4\text{-leptons}$ with 13 fb^{-1} data
 - $H \rightarrow WW(*) \rightarrow l\nu l\nu$ with 13 fb^{-1} data
 - $H \rightarrow \tau\tau$ with 13 fb^{-1} data
 - Associated production $H \rightarrow b\bar{b}$ with 13 fb^{-1} data
 - Combination of the above channels including $H \rightarrow \gamma\gamma$ (“ICHEP” data)

Latest results from ATLAS and CMS

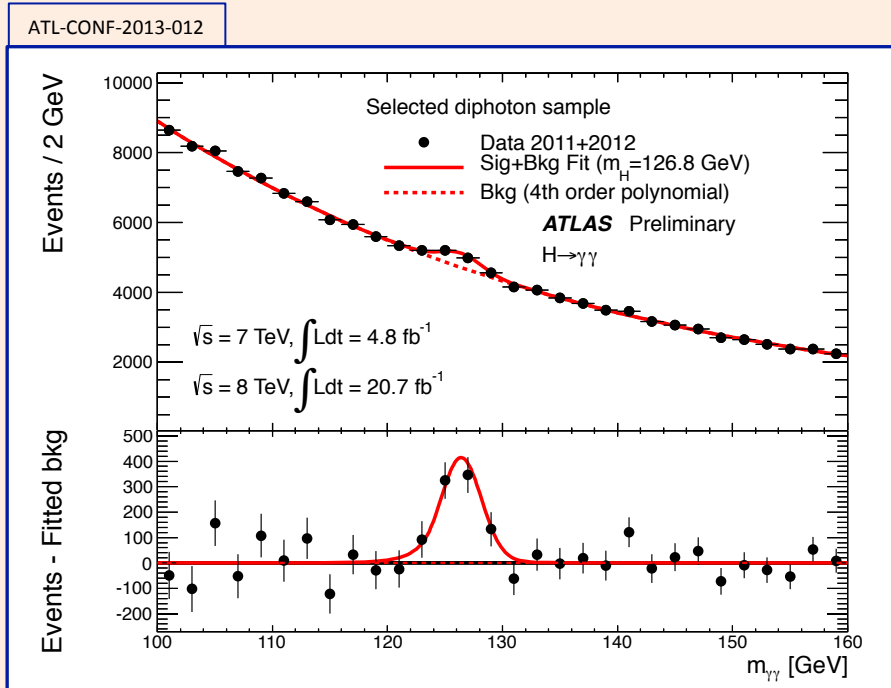

Invariant mass distribution of diphoton candidates for the combined $\sqrt{s} = 7$ TeV and $\sqrt{s} = 8$ TeV data samples. The fit to the data is the sum of a signal component fixed to $m_H = 126.8$ GeV and a background component described by a fourth-order Bernstein polynomial. Bottom inset: display of the residuals of the data with respect to the fitted background.

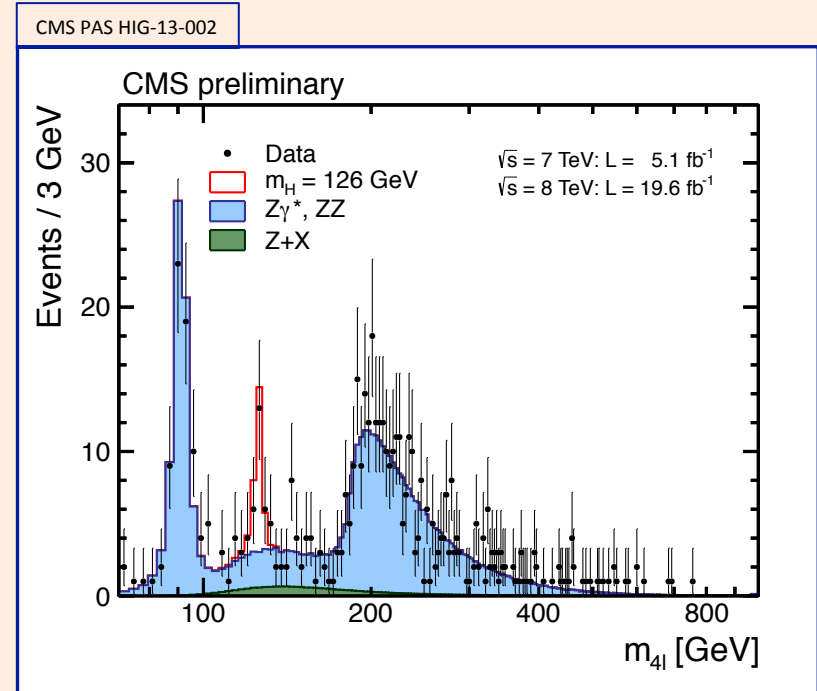

Four-lepton reconstructed mass for the sum of the $4e$, 4μ , and $2e2\mu$ channels. Points represent the data, shaded histograms represent the background and unshaded histogram the signal expectations

Latest results from ATLAS and CMS

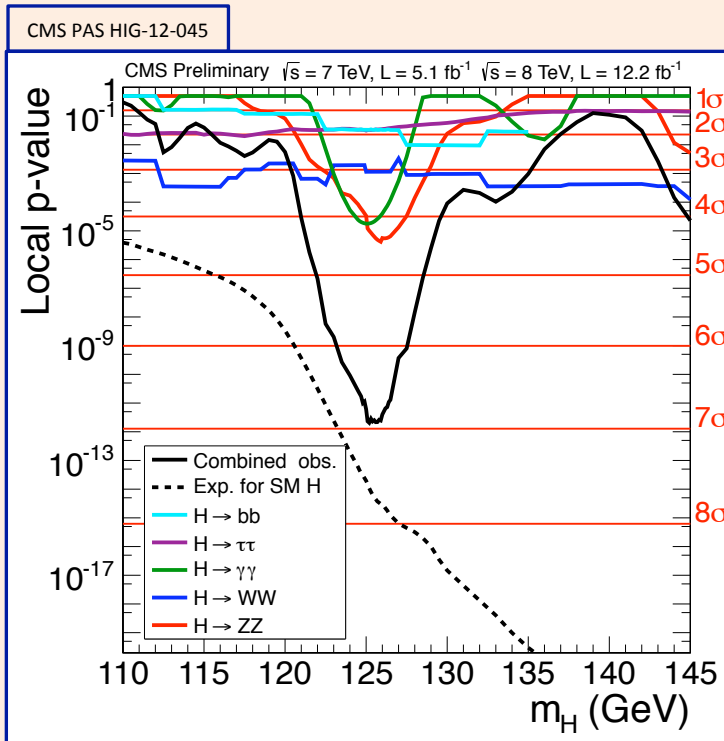

The observed local p-value for the five decay modes and the overall combination as a function of the SM Higgs boson mass in the range 110–1000 GeV (left) and 110–145 GeV (right). The dashed lines show the expected local p-values for a SM Higgs boson with a mass m_H .

Local significance: 6.9 σ

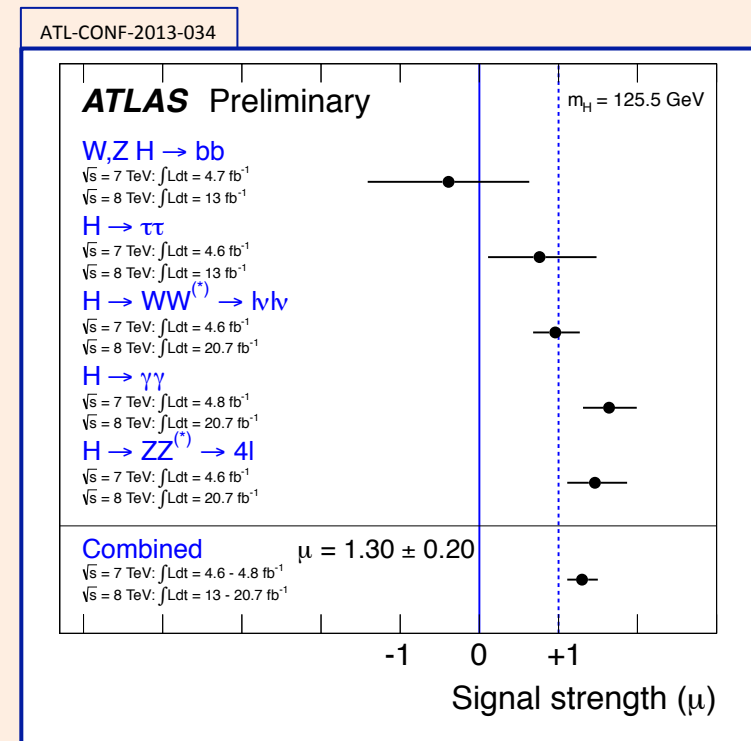

Measurements of the signal strength parameter μ for m_H at 126 GeV for the individual channels and their combination.

$$\mu = 1.43 \pm 0.21 \text{ for } m_H = 125.5 \text{ GeV}$$

A lot of details in many talks in this Conference

Searches for New Physics: SUSY

ATLAS

ATLAS SUSY Searches* - 95% CL Lower Limits (Status: Dec 2012)

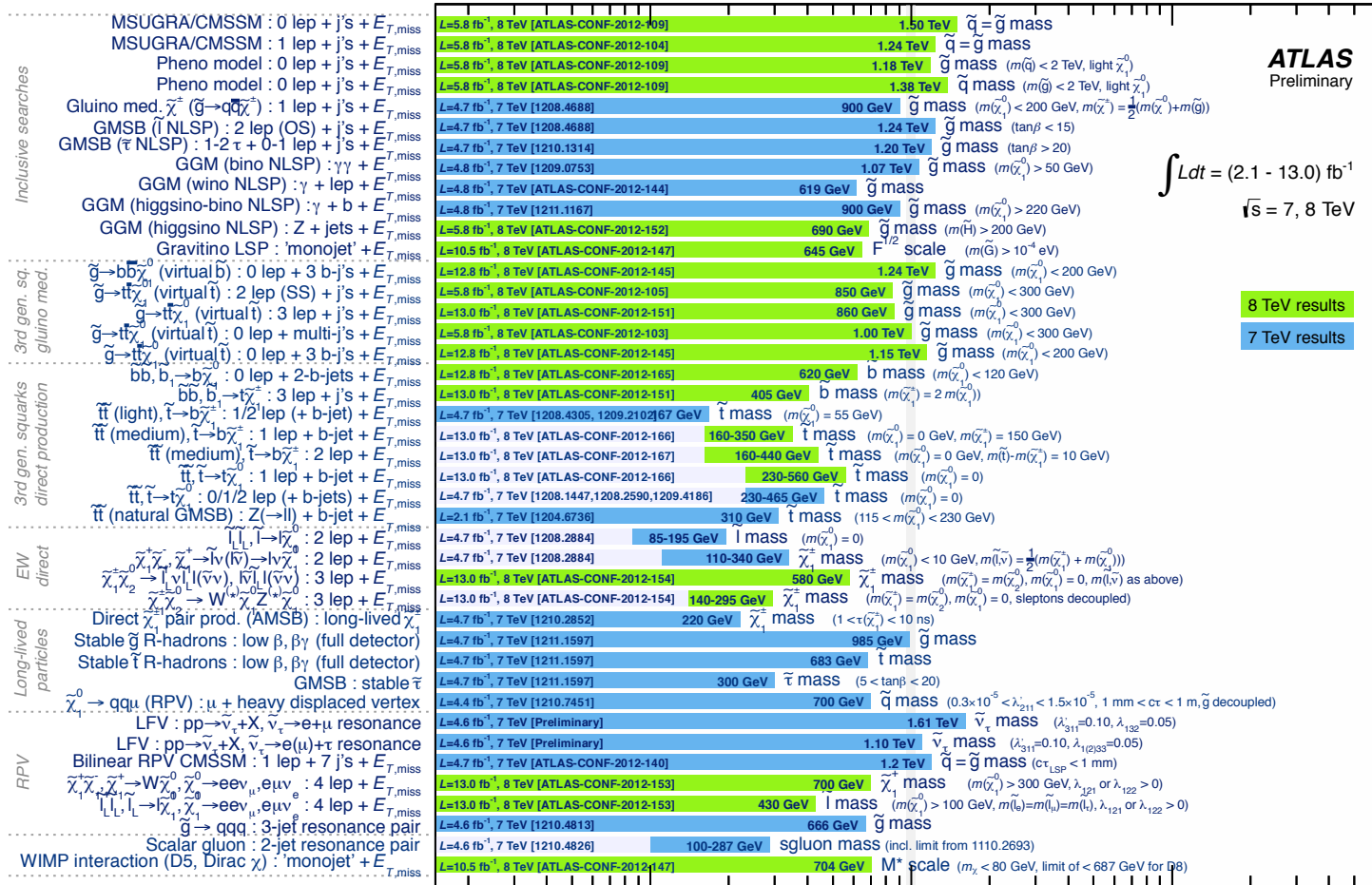

*Only a selection of the available mass limits on new states or phenomena shown.
 All limits quoted are observed minus 1σ theoretical signal cross section uncertainty.

See talks from Isabel Trigger and Markus Stoye

Searches for New Physics: Exotics

CMS

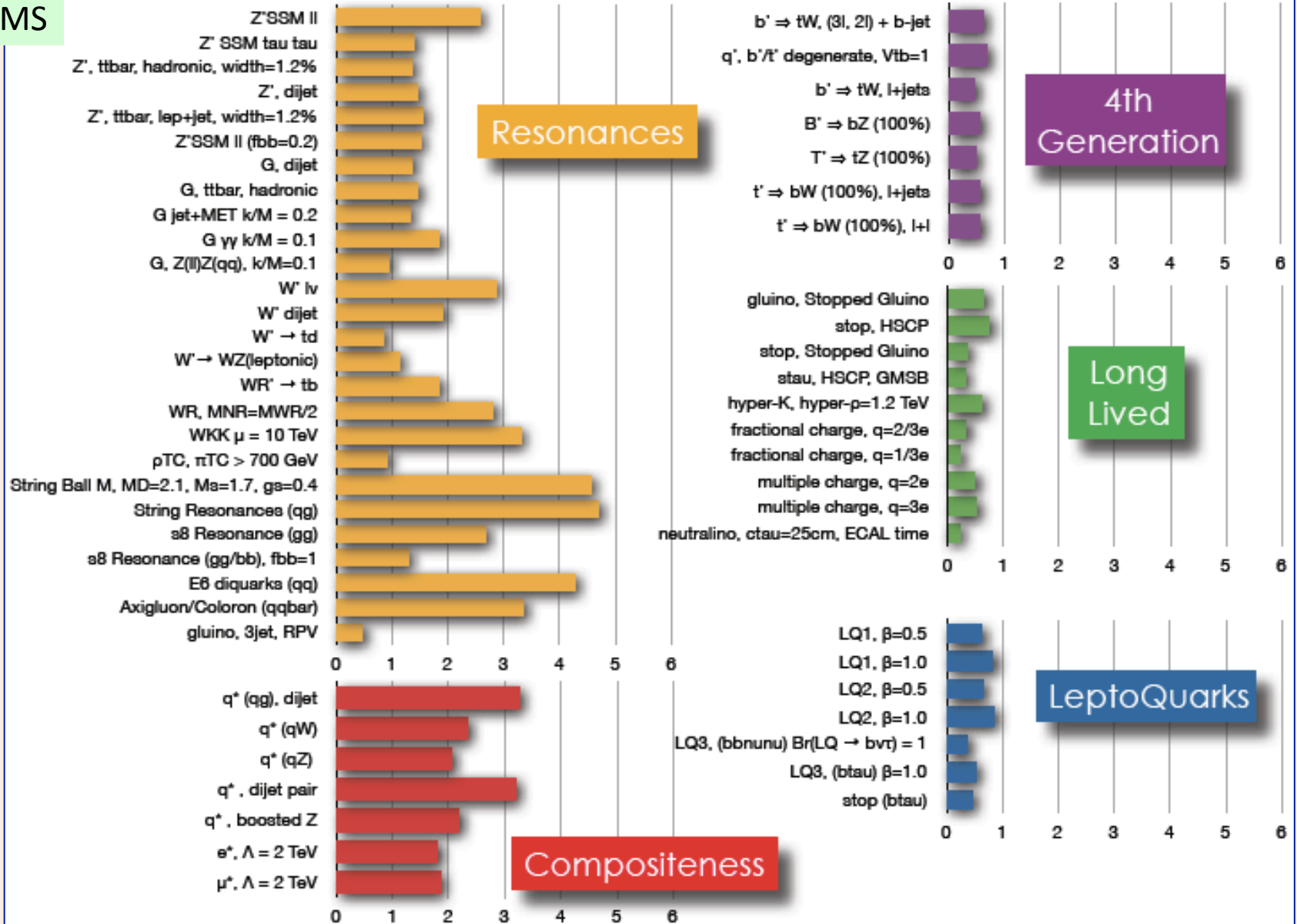

Searches for New Physics: Exotics

CMS

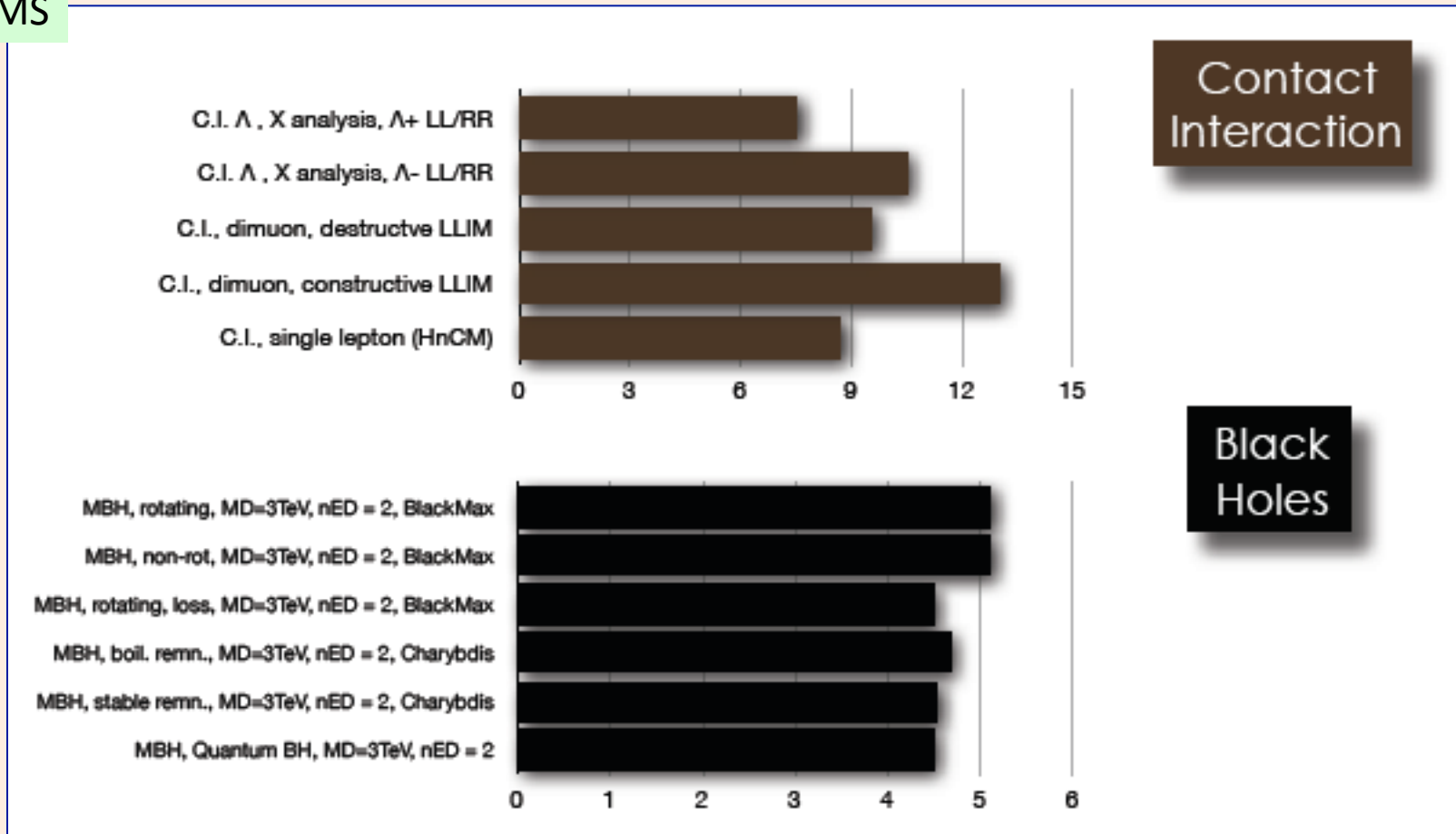

See talks from Samuel Pierre Jean Calvet and Sung Won Lee

The priorities for energy frontier physics after July 4th

- The recently discovered new particle drives to a number of fundamental open points that are top priority for the physics programme for the LHC and future energy frontier accelerators:
 1. Precision measurement of the mass and of the natural width of this new particle
 2. Determination of the quantum numbers spin and parity, J^P , and CP properties
 3. Measurement of couplings to elementary fermions and bosons
 4. Measurement of the self-coupling strength
 5. Comparison of these physics properties with those predicted by Standard Model
 6. Search for possible partners (neutral/charged) of this boson
 7. Is this particle a fundamental object, or it is composite?

The priorities for energy frontier physics after July 4th

- The investigations of the electroweak symmetry breaking cannot be limited to the study of the Higgs sector only: several points still to be addressed. Among these:
 - The dependence with energy of the Vector Boson Scattering cross section (WW, WZ and ZZ)
 - The hierarchy problem, that motivated new theories beyond SM, such as SUpErSYmmetry, Extra-Dimensions, Technicolor models, etc. etc.
 - ...

The priorities for energy frontier physics after July 4th

- This enriches the collider physics programme:
 8. Analyse the Vector Boson scattering cross section to study whether the cross-section regularization is operated by the Higgs boson (as predicted by SM) or (also) by other processes associated to physics beyond SM;
 9. Continue the search for SUSY particles, in particular search for third generation squarks: to be effective, the mass of the stop quark cannot be too different from the one of the top quark; also continue the search for gauginos and for 1st and 2nd generation squarks;
 10. Continue the search for heavy resonances decaying to photon, lepton or quark pairs, and for deviations from SM of physics distributions highly sensitive to New Physics (di-jet angular distribution,...)

The European Strategy for Particle Physics

- These themes have been widely discussed in the context of the Symposium on the European Strategy for Particle Physics, held on September 10 to 12, 2012.
- Many proposals have been submitted (collider energy frontier physics, heavy flavour physics, neutrino and astroparticle physics, etc. etc.)

CERN Council Open Symposium on
European Strategy for Particle Physics

10 – 12 September 2012, Kraków, Poland

AGH UST, IFJ PAN, The M. Smoluchowski Scientific Consortium, Kraków
Foundation for the AGH University of Science and Technology

The European Strategy for Particle Physics

- These themes have been widely discussed in the context of the Symposium on the European Strategy for Particle Physics, held on September 10 to 12, 2012.
- Many proposals have been submitted (collider energy frontier physics, heavy flavour physics, neutrino and astroparticle physics, etc. etc.)



Meeting of the Strategy Group for Particle Physics held in Erice from 21 to 25 January

More information on the outcome of this meeting given at the end of this talk

The European Strategy for Particle Physics

- High Energy Frontier:

Based on the Physics Briefing Book
CERN-ESG-005 , 13 January 2013

Name	beams	collider geometry	\sqrt{s} , TeV	luminosity	Operation (years)
HL-LHC	pp	circular	14	3000 fb⁻¹	2024-2030
HE-LHC	pp	circular	26-33	100-300 fb⁻¹/year	After 2035
VHE-LHC	pp	circular	40-100	-	After 2035
LEP3	e⁺e⁻	circular	0.240	1•10³⁴ cm⁻²s⁻¹	After 2024
ILC	e⁺e⁻	linear	0.250→1.0	~1•10³⁴ cm⁻²s⁻¹	~ 2030
CLIC	e⁺e⁻	linear	0.500→3.0	2-6•10³⁴ cm⁻²s⁻¹	After 2030
TLEP	e⁺e⁻	circular	0.24-0.350	5•10³⁴ cm⁻²s⁻¹	After 2035
LHeC	e⁻(e⁺)p	circular		O(100 fb⁻¹)	After 2022
$\gamma\gamma$-collider	$\gamma\gamma$?
μ-collider	$\mu^+\mu^-$	circular			?

I'll focus on examples of physics perspectives at the High Luminosity-LHC (HL-LHC)

The European Strategy for Particle Physics

- High Energy Frontier:

Based on the Physics Briefing Book
CERN-ESG-005 , 13 January 2013

Name	beams	collider geometry	vs, TeV	luminosity	Operation (years)
HL-LHC	pp	circular	14	3000 fb ⁻¹	2024-2030
HE-LHC	pp	circular	26-33	100-300 fb ⁻¹ /year	After 2035
VHE-LHC	pp	circular	40-100	-	After 2035
LEP3	e ⁺ e ⁻	circular	0.240	1•10 ³⁴ cm ⁻² s ⁻¹	After 2024
ILC	e ⁺ e ⁻	linear	0.250→1.0	~1•10 ³⁴ cm ⁻² s ⁻¹	~ 2030
CLIC	e ⁺ e ⁻	linear	0.500→3.0	2-6•10 ³⁴ cm ⁻² s ⁻¹	After 2030
TLEP	e ⁺ e ⁻	circular	0.24-0.350	5•10 ³⁴ cm ⁻² s ⁻¹	After 2035
LHeC	e ⁻ (e ⁺)p	circular		O(100 fb ⁻¹)	After 2022
γγ-collider	γγ				?
μ-collider	μ ⁺ μ ⁻	circular			?

→ HL-LHC: see talk by Mike Lamont; Future accelerators: by Marc Ross
→ Linear Collider plans & physics discussed by Sachio Komamya

The LHC Upgrade plan

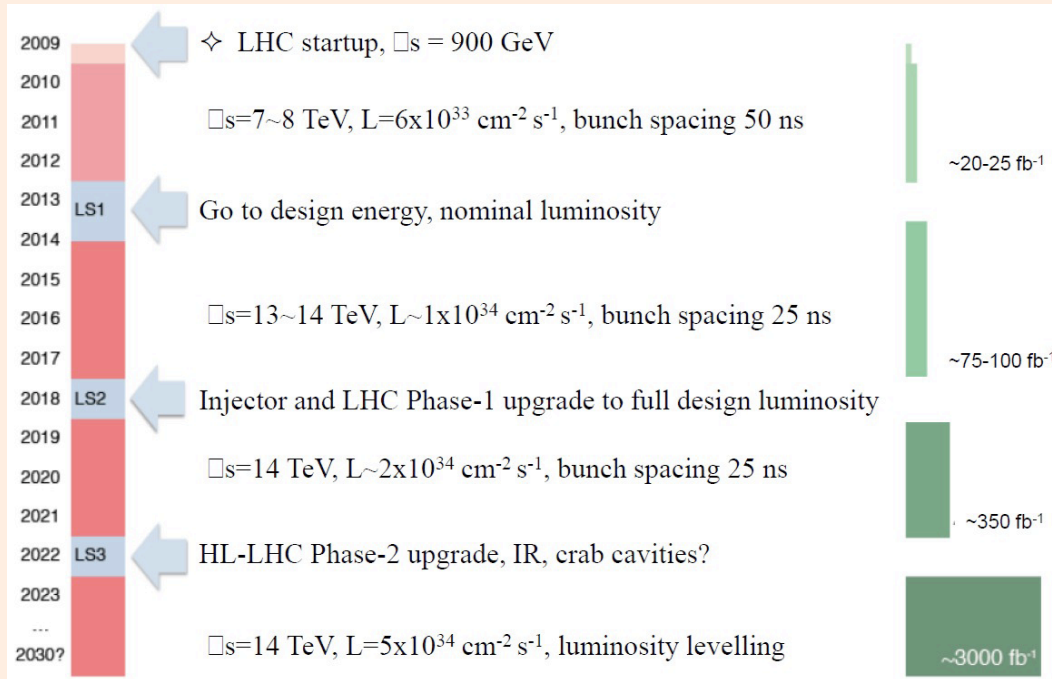

About 350 fb^{-1} are expected at the end of the LHC Programme

– 300 fb^{-1} have been assumed as baseline in the studies made by ATLAS and CMS

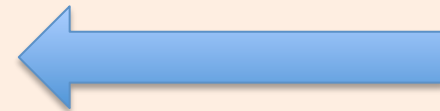

- Experimental challenges
 - The average number of proton-proton collisions per triggered events is about 140
 - The trigger has to cope with the effects induced by the large pile-up
 - The inner detector has to be fast and with high granularity and redundancy, to cope with the effects from large occupancy
 - The detector has to be (even more) radiation hard

The LHC Upgrade plan

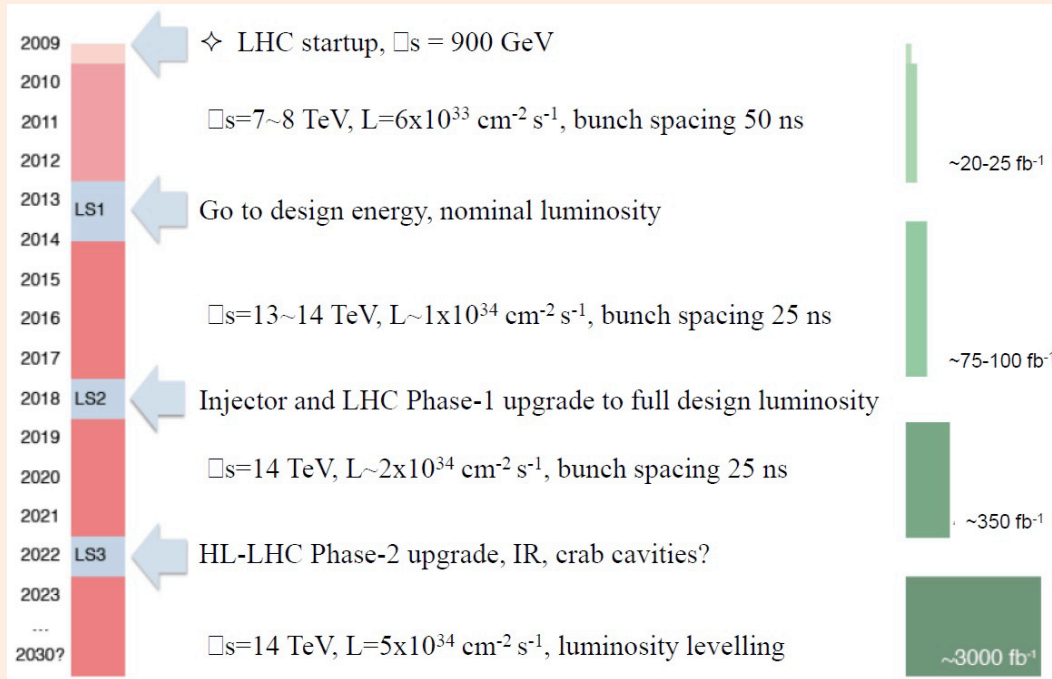

About 350 fb⁻¹ are expected at the end of the LHC Programme

– 300 fb⁻¹ have been assumed as baseline in the studies made by ATLAS and CMS

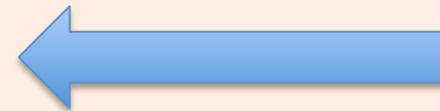

- Experimental challenges
 - The average number of proton-proton collisions per triggered events is about 140
 - The trigger has to cope with the effects induced by the large pile-up
 - The inner detector has to be fast and with high granularity and redundancy, to cope with the effects from large occupancy
 - The detector has to be (even more) radiation hard

Event pileup at the LHC

- Present ATLAS and CMS detectors have been designed for $\langle \mu \rangle \sim 23$ pp interactions / bunch-crossing
 - And continue to do an excellent job with 35

$Z \rightarrow \mu\mu$ decay in a large pileup event

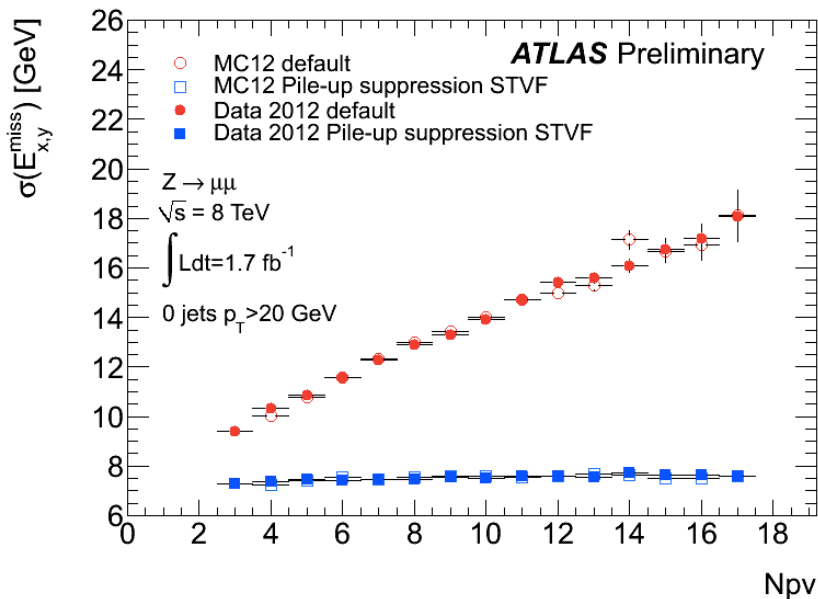
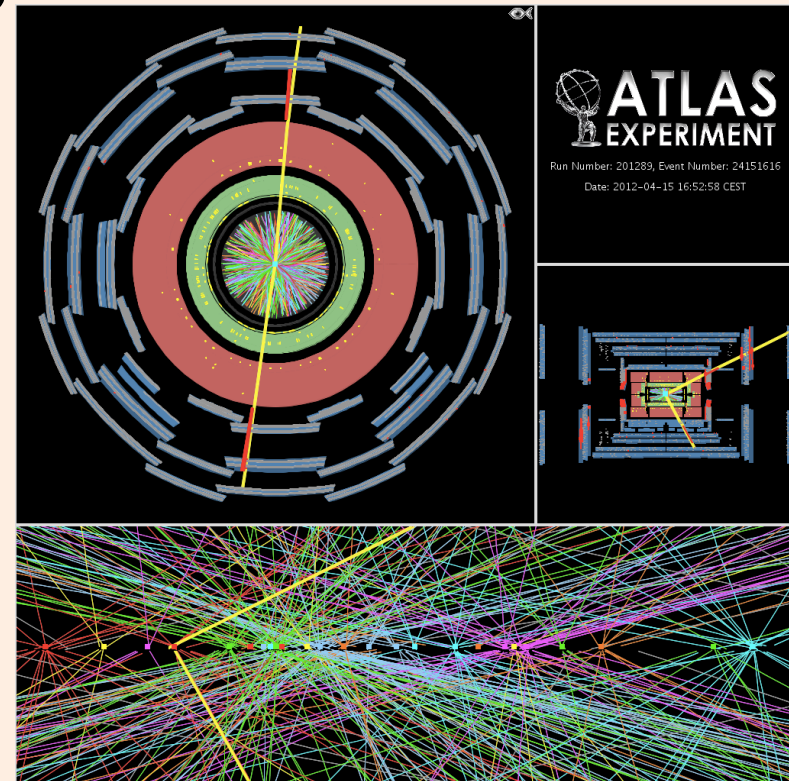

Missing transverse energy resolution as a function of the number of the reconstructed vertices

- But cannot handle (an average of) 140 events of pileup

Physics at HL-LHC

- On the basis of what discussed in the previous slides, ATLAS and CMS presented two documents for the Symposium in Cracow, subsequently updated in October 2012 for the Briefing Book
- These documents focused on:
 - Higgs couplings, confirm spin, CP and self-couplings
 - Vector Boson Scattering
 - SUSY
 - Exotics
 - SM: Vector Boson TGCs and top quark FCNC

Approaches adopted for physics perspectives estimation

- ATLAS: perform physics simulation with a fast procedure based on simple functions applied to physics objects (electrons, photons, muons, tau, jets, b-jets, missing transverse energy) to mimic the effects from energy (momentum) resolution; acceptance, identification and reconstruction efficiencies, b-tagging efficiencies, fake rates
- CMS: the upgraded detector will compensate the effects from event pile-up; assume three different scenarios:
 - Scenario 1: all systematic uncertainties are kept unchanged wrt those in current data analyses
 - Scenario 2: the theoretical uncertainties are scaled by a factor of $1/2$, while other systematic uncertainties are scaled \sqrt{L} ;
 - Scenario 3: set theoretical uncertainties to zero, to demonstrate their interplay with the experimental uncertainties;
 - → The truth will be most likely somewhere between Scenario 1 and 2

Higgs Couplings at the LHC

- The LHC programme will be completed by about 2021 with an integrated luminosity around 300 fb^{-1} .
- Important progress can be made on the analysis of the physics properties of the Higgs-like boson recently discovered

<https://indico.cern.ch/contributionDisplay.py?contribId=177&confId=175067>

CMS Projection

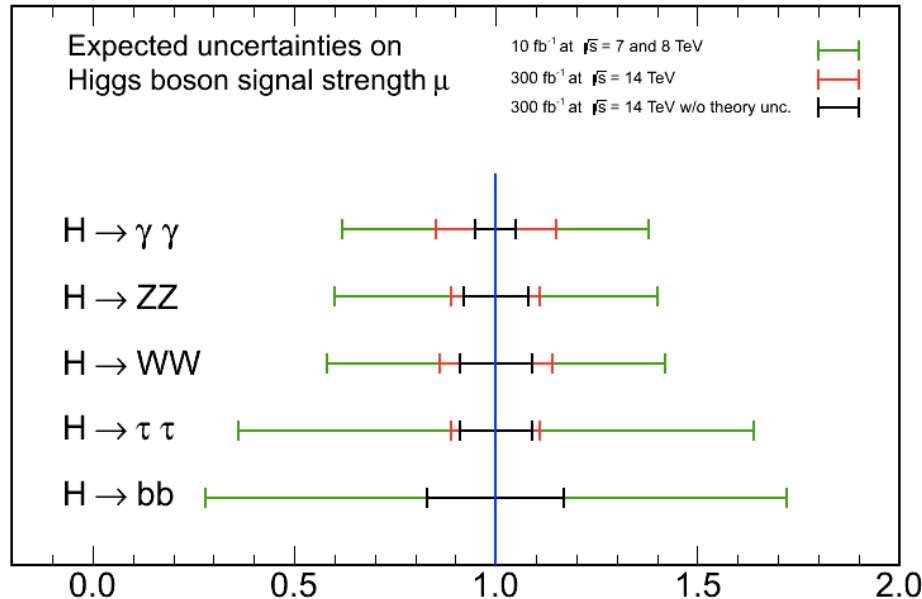

- Estimated precision of the signal strength determination for a SM Higgs boson
- Projections for $L=300 \text{ fb}^{-1}$ and $\sqrt{s} = 14 \text{ TeV}$

┆┆┆ Current data
┆┆┆ Scenario 1
┆┆┆ Scenario 3

Signal strengths consistency with SM predictions can be tested with 10% accuracy

Higgs Couplings at the HL-LHC

- ATLAS has performed projection studies to HL-LHC, assuming up to 3000 fb^{-1} of data
- focused on the main channels already under study with LHC data, plus a few rare decay channels sensitive to top and muon couplings

ATL-PHYS-PUB-2012-004

	ggF	VBF H	WH	ZH	ttH
$H \rightarrow \gamma\gamma$	✓	✓	✓	✓	✓
$H \rightarrow ZZ^*$	✓				
$H \rightarrow WW^*$	✓	✓	✓		
$H \rightarrow \tau\tau$	extrap.	✓			
$H \rightarrow \mu\mu$	✓				✓

- ZH, $H \rightarrow bb$ was studied, but S/B is bad and it is very difficult at present to estimate systematic uncertainties at $L=5 \times 10^{34} \text{ cm}^{-2} \text{ s}^{-1} \rightarrow$ not included in the available ES ATLAS studies

ttH , $H \rightarrow \gamma\gamma$ and $H \rightarrow \mu\mu$

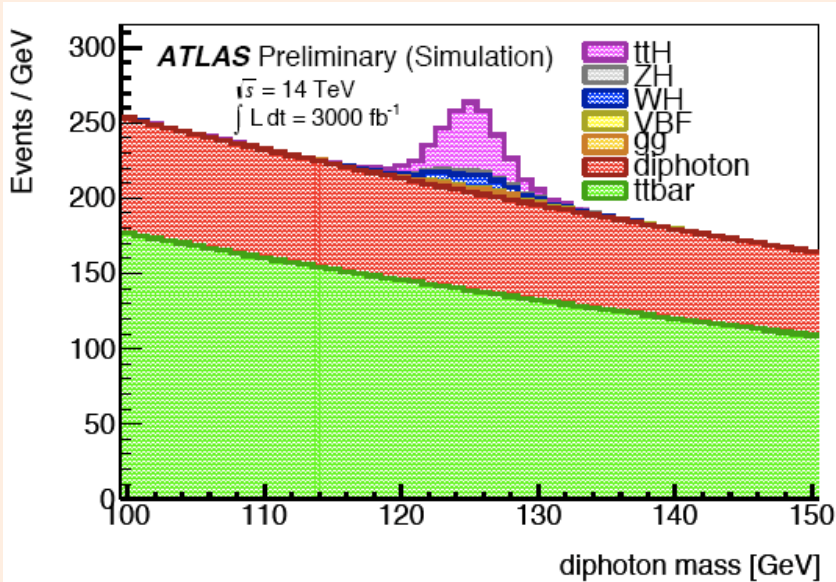

- Important for H-top coupling measurement
- Require multi-jet high- p_T jets
- Analyse 1-lepton and 2-lepton events
- Require very high luminosity
 - $S/\sqrt{B} \sim 6$
 - A factor 2 better than 300 fb^{-1}

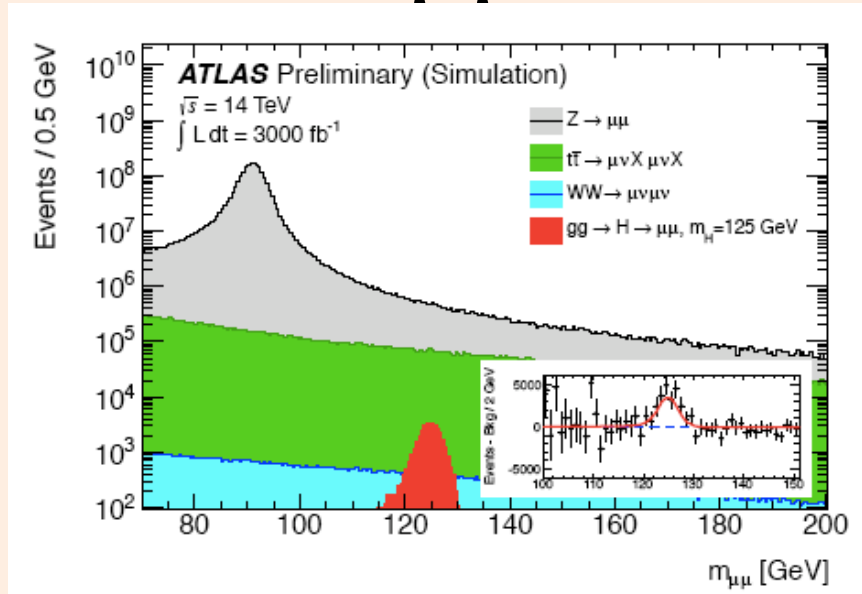

- One of the best channels to study Higgs boson couplings to fermions
- Very rare: deviations from the expected rate would indicate new physics
 - Large background from $Z \rightarrow \mu\mu$
- Analysis included background modeling uncertainties
- More than 6 sigma at $L=3000 \text{ fb}^{-1}$

Higgs Couplings at the HL-LHC

ATLAS Preliminary (Simulation)

$\sqrt{s} = 14$ TeV: $\int L dt = 300 \text{ fb}^{-1}$; $\int L dt = 3000 \text{ fb}^{-1}$
 $\int L dt = 300 \text{ fb}^{-1}$ extrapolated from 7+8 TeV

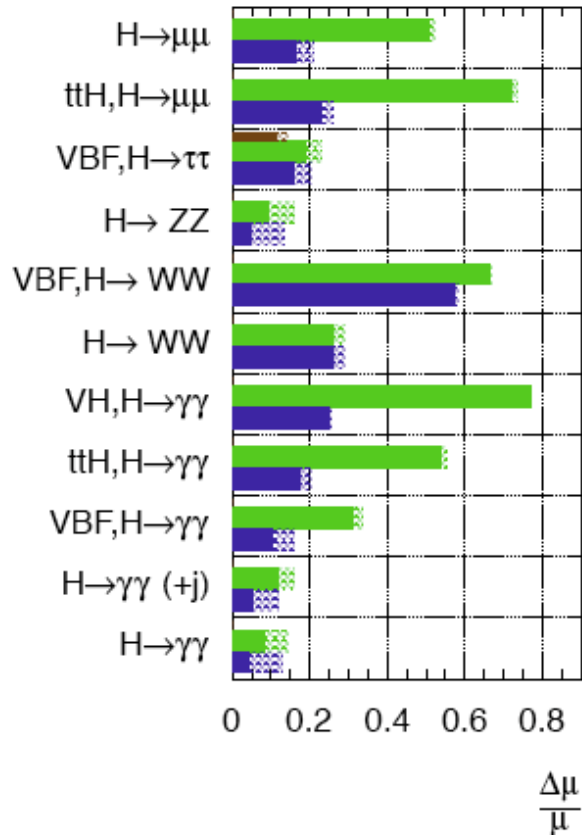

ATLAS Preliminary (Simulation)

$\sqrt{s} = 14$ TeV: $\int L dt = 300 \text{ fb}^{-1}$; $\int L dt = 3000 \text{ fb}^{-1}$
 $\int L dt = 300 \text{ fb}^{-1}$ extrapolated from 7+8 TeV

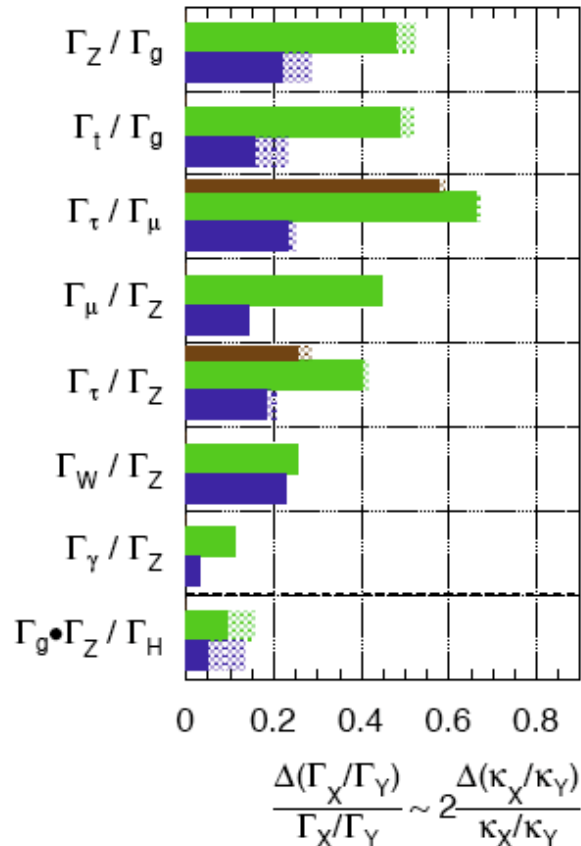

Left: Expected measurement precision on the signal strength $\mu = (\sigma \times \text{BR}) = (\sigma \times \text{BR})_{\text{SM}}$ in all considered channels.

Right: Expected measurement precisions on ratios of Higgs boson partial widths without theory assumptions on the particle content in Higgs loops or the total width.

Expected precision for the determination of the coupling scale factors k_V and k_F . No additional BSM contributions are allowed in either loops or in the total width (numbers in brackets include current theory systematic uncertainties).

	300 fb^{-1}	3000 fb^{-1}
k_V	3.0% (5.6%)	1.9% (4.5%)
k_F	8.9% (10%)	3.6% (5.9%)

Higgs Couplings at the HL-LHC

CMS Coupling	Uncertainty (%)			
	300 fb ⁻¹		3000 fb ⁻¹	
	Scenario 1	Scenario 2	Scenario 1	Scenario 2
κ_γ	6.5	5.1	5.4	1.5
κ_V	5.7	2.7	4.5	1.0
κ_g	11	5.7	7.5	2.7
κ_b	15	6.9	11	2.7
κ_t	14	8.7	8.0	3.9
κ_τ	8.5	5.1	5.4	2.0

- Coupling CMS projection: In the first one (Scenario 1) all systematic uncertainties are kept unchanged. In the second one (Scenario 2) the theoretical uncertainties are scaled by a factor of 1/2, while other systematic uncertainties are scaled by the square root of the integrated luminosity.

Couplings can be measured at the level of few %

Some proposals for future colliders

See also: arxiv:1302.3318

LEP3

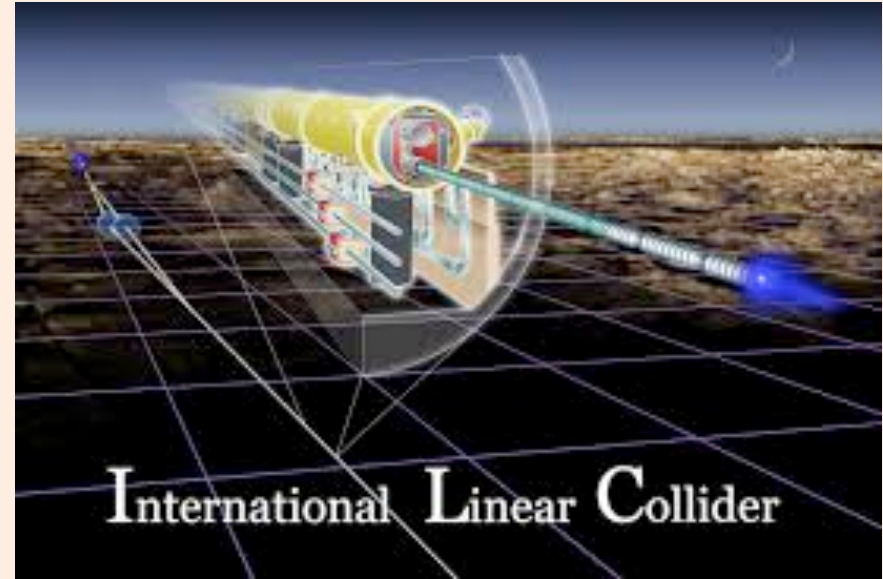
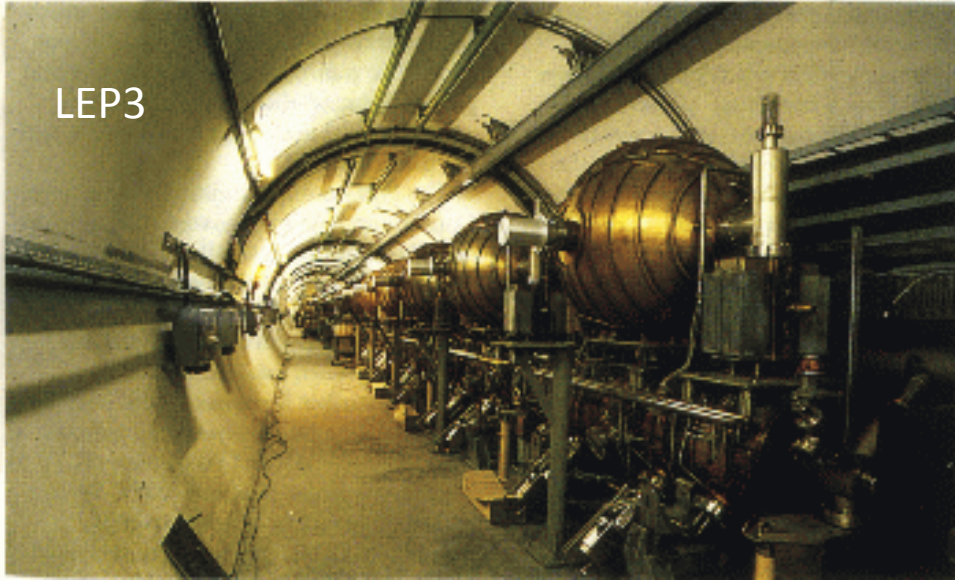

CLIC

drive beam 100 A, 239 ns
2.38 GeV → 240 MeV

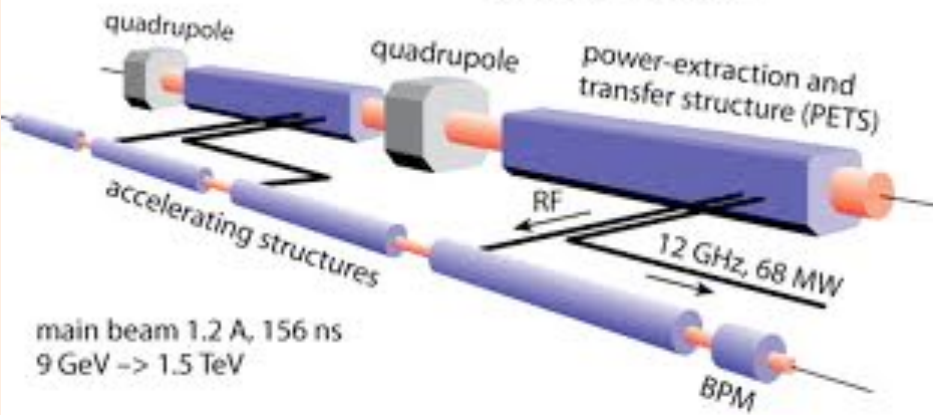

TLEP/VHE-LHC

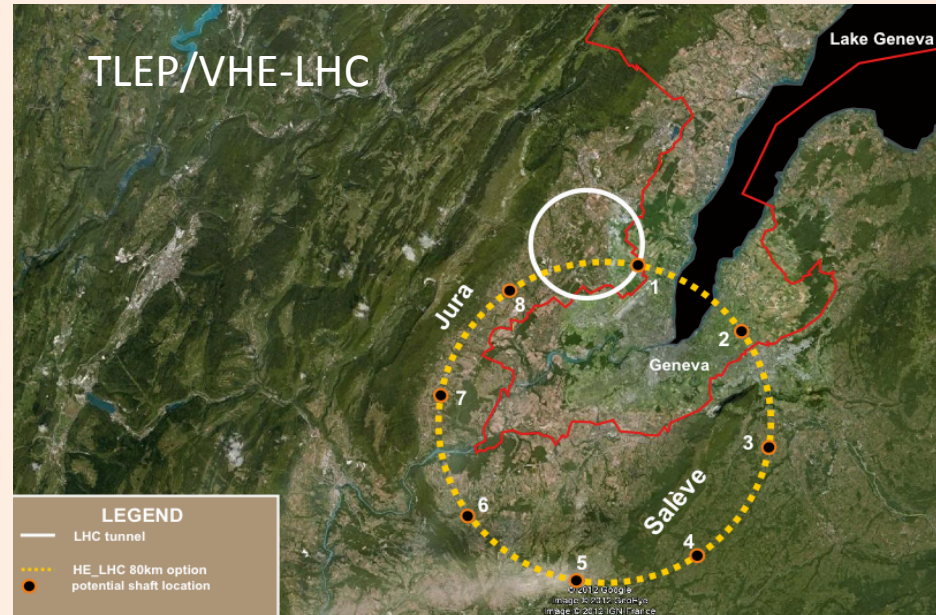

Higgs couplings for Precision Higgs Factories

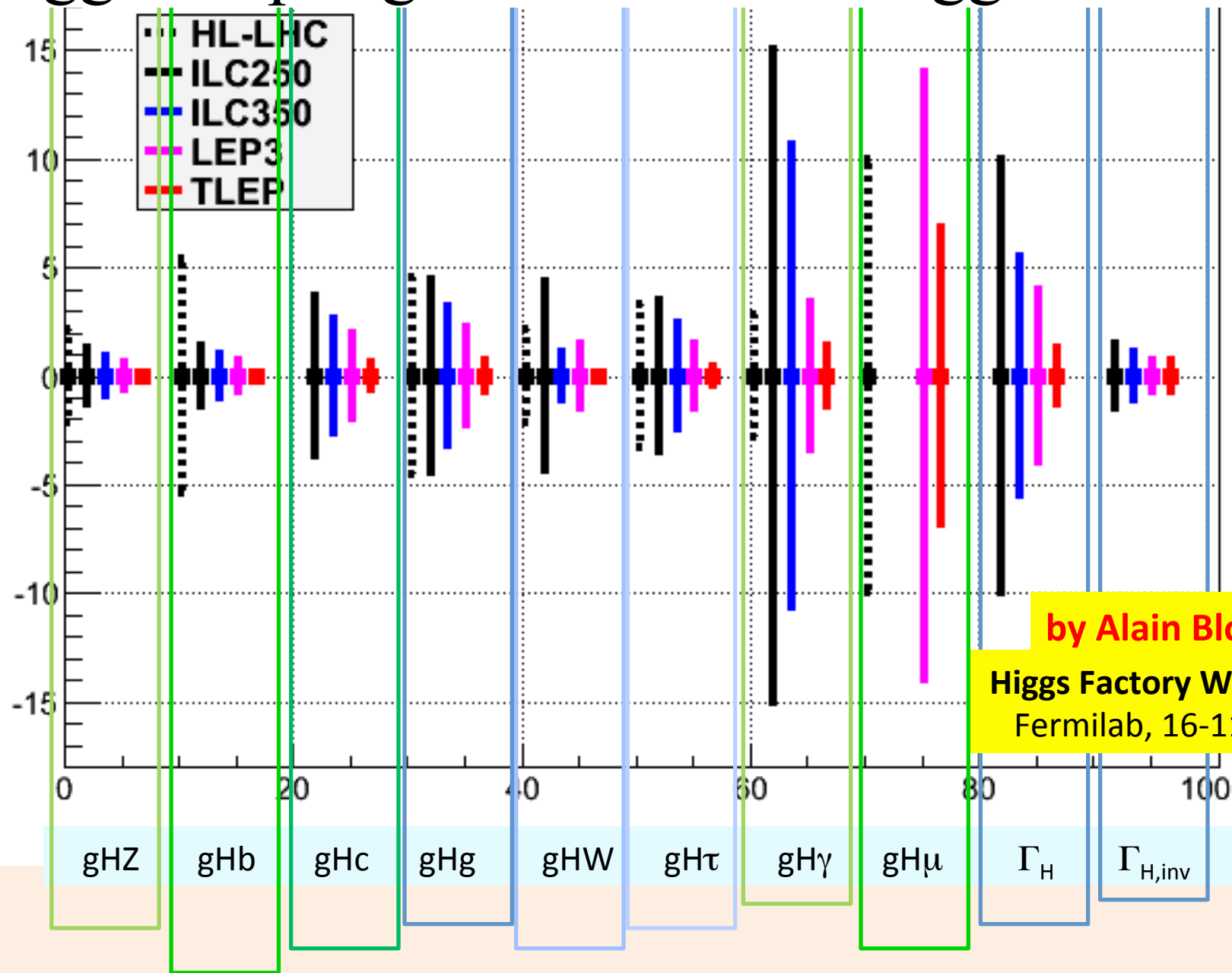

by Alain Blondel

Higgs Factory Workshop

Fermilab, 16-11-2012

Higgs boson Self-Coupling

- The only way to reconstruct the scalar potential of the Higgs doublet field, that is responsible for spontaneous electroweak symmetry breaking, it is necessary to measure the Higgs boson self-interactions

$$\lambda_{HHH} = \frac{3M_H^2}{v}$$

$$V_H = \mu^2 \Phi^\dagger \Phi + \frac{1}{2} \lambda (\Phi^\dagger \Phi)^2 ; \quad \lambda = \frac{M_H^2}{v^2} \text{ and } \mu^2 = -\frac{1}{2} M_H^2$$

A. Djouadi, et al., Eur. Phys. J. C10 (1999), 45

gluon-gluon fusion

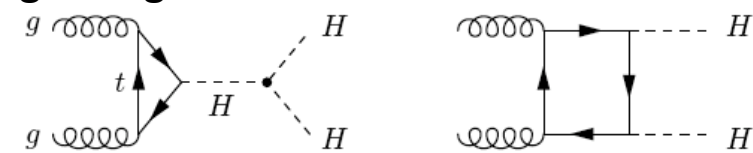

Vector Boson Fusion

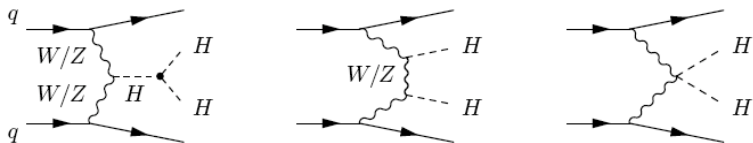

Higgs-strahlung

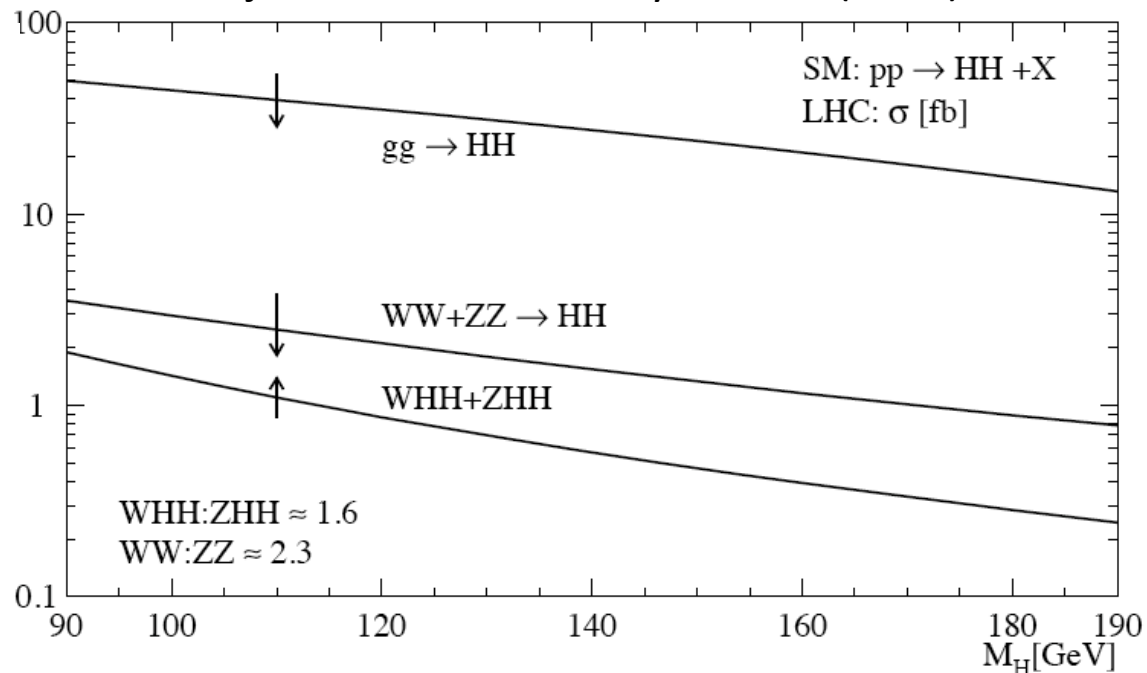
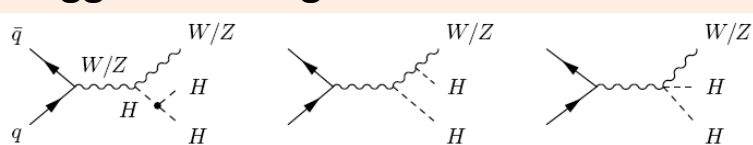

$$\sigma_{HH} (14 \text{ TeV}) = 33.89 +18\%-15\% (\text{QCD}) \pm 7\% (\text{PDF}+\alpha_s) \pm 10\% (\text{EFT}) \text{ fb} \rightarrow +37.2 -29.8 \text{ fb}$$

A. Djouadi, et al., <http://arxiv.org/abs/1212.5581>

Higgs Self-Coupling

ATL-PHYS-PUB-2012-004
ATL-PHYS-PUB-2013-001

Decay channel	Branching ratio (%)	Events @ 14 TeV (L = 3,000 fb ⁻¹)
bb + bb	33.4084	33,976
bb + W ⁺ W ⁻	24.9696	25,394
bb + τ ⁺ τ ⁻	7.3638	7,488
W ⁺ W ⁻ + W ⁺ W ⁻	4.6656	4,745
ZZ + bb	3.0866	3,138
ZZ + W ⁺ W ⁻	1.1534	1,174
γγ + bb	0.2658	270
γγ + γγ	0.0010	1

Expected SM HH yields for proton-proton collisions at $\sqrt{s} = 14$ TeV and L=3000 fb⁻¹

- The “trouble” with a 125 GeV Higgs: it decays in many final states with similar “small” B.R. This is very good for couplings, but opens real challenges for HH final states, characterized by small production rates.
- The selection of HH processes has to account for:
 - Final states experimentally clear and robust
 - Final states with large enough production rates

Two channels have been considered by ATLAS for the “European Strategy”:

1. **HH → bbWW**
2. **HH → bbγγ**

HH \rightarrow bbWW

- BR \sim 25% \rightarrow 2.6×10^4 events in 3000 fb^{-1} at 14 TeV;
 - This includes all W decay modes
- The ttbar process represents a severe background for this final state;
- Study done considering one W decaying hadronically, the other leptonically (e, μ ; treated separately)
- Select events with high lepton p_T , large missing transverse energy, four high- p_T jets, of which two b-tagged;
- The result of the study shows how challenging is extract HH production from this channel
 - We select \lesssim 1000 signal events on top of 10^7 ttbar events
 - S/B in agreement with estimates performed by other authors (M.J. Dolan et al., arXiv:1206.5001v2 [hep-ph])

HH \rightarrow bb $\gamma\gamma$

- BR $\sim 0.27\%$, $\sigma \times \text{BR} \sim 0.09 \text{ fb} \rightarrow 260 \text{ HH}$ events in 3000 fb^{-1} at 14 TeV;
- bb $\gamma\gamma$, Zbb, Hbb, ttbar are important backgrounds
- Select events with high- p_T photons, two jets b-tagged; reconstruct the invariant mass of the b-jets and of the photons and select events with $m_{\gamma\gamma}$ and $m_{bb} = m_Z$ within experimental mass resolution

HH \rightarrow bb $\gamma\gamma$

ATLAS Note: ATL-PHYS-PUB-2013-001

sample	$\sigma \times \text{BR}$ (fb)	simulated events	events passing selection	events expected in 3000 fb $^{-1}$
$HH \rightarrow b\bar{b}\gamma\gamma$ ($\lambda_{HHH} = 1$)	0.09	1020	42	10.7
$HH \rightarrow b\bar{b}\gamma\gamma$ ($\lambda_{HHH} = 0$)	0.19	1020	32	17.9
$HH \rightarrow b\bar{b}\gamma\gamma$ ($\lambda_{HHH} = 2$)	0.04	1230	66	6.4
$\gamma\gamma b\bar{b}$	111	3.1×10^4	1	1.1
$ZH(Z \rightarrow b\bar{b}, H \rightarrow \gamma\gamma)$	0.04	5×10^5	11600	2.8
$b\bar{b}H(H \rightarrow \gamma\gamma)$	0.124	5×10^4	71	0.5
$\gamma\gamma jj$	2×10^3	5×10^5	0.004	0.1
$jjjj$	1.8×10^8	4.6×10^6	0	0
$t\bar{t}H(H \rightarrow \gamma\gamma)$	1.71	1.2×10^5	379	13.6
$t\bar{t}$ (≥ 1 leptonic W decay)	5.0×10^5	1×10^7	74 †	1.1
Total Background	-	-	-	19.2

- Select 11 HH events with a total background yield of 19 events
- Assuming that we can add another channel with similar performances (HH $\rightarrow\tau\tau b\bar{b}$?) and two experiments, we can reach a measurement of the Higgs boson selfcoupling with an accuracy of $\sim 30\%$

Details in the talk by Evelin Meoni

Higgs boson CP

- Explore the ATLAS sensitivity to the CP-violating part of the HZZ scattering amplitude:

$$A(X \rightarrow VV) \sim \left(a_1 M_X^2 g_{\mu\nu} + a_2 (q_1 + q_2)_\mu (q_1 + q_2)_\nu + a_3 \varepsilon_{\mu\nu\alpha\beta} q_1^\alpha q_2^\beta \right) \varepsilon_1^{*\mu} \varepsilon_2^{*\nu}$$

- ε : polarisation vectors of the gauge bosons, form factors a_1 and a_2 refer to CP-even boson with mass M_X , a_3 to a CP-odd boson
 - The presence of the two CP terms can lead to CP violation
 - In SM $a_1=1$; $a_2=a_3=0$
- In this study we have set $a_1=1$; $a_2=0$, and varied a_3

Luminosity	Signal and Background	$6 + 6i$	$6i$	$4 + 4i$
100 fb^{-1}	$S = 51.5; B = 58.2$	3.54	3.22	3.16
200 fb^{-1}	$S = 103; B = 116.4$	4.91	4.37	4.27
300 fb^{-1}	$S = 154.5; B = 174.6$	5.92	5.20	5.06

Expected significances in sigma to reject a CP-violating state in favour of 0+ hypothesis as a function of integrated luminosity for various strength of CP-violating contribution.

Precise measurement of smaller form factors which are more likely to be realized will require higher luminosities only accessible at HL-LHC. A similar conclusion can be drawn for the observation of anomalous form factor a_2

Vector Boson Scattering

- In the Standard Model, the Higgs boson preserves the unitarity of scattering amplitudes in longitudinal Vector Boson Scattering (VBS)
- However new physics can contribute to the regularization of of the VBS cross-section or else enhancing it.
 - Example: in Technicolor models predict the appearance of resonances in the V - V invariant mass distribution
- → the study of VBS properties at the LHC is a mandatory step to test the effects of the SM Higgs boson (if the existence will be confirmed) or from New Physics BSM.

See also talk by Paolo Giacomelli

Vector Boson Scattering

- At LHC VBS are tagged with two forward high- p_T jets on either side, the remnants of the quarks that have emitted the W/Z bosons in the central rapidity region: WW+2jets, WZ+2jets, ZZ+2jets
- ATLAS has performed preliminary studies of the process $pp \rightarrow ZZjj \rightarrow 4l+jj$ within the “Pade” unitarization (IAM, Inverse Amplitude Method) and using the WHIZARD generator (it allows to generate weak boson scattering mediated by a new high-mass resonance in presence of a Higgs boson with 126 GeV mass)

ATL-PHYS-PUB-2012-005

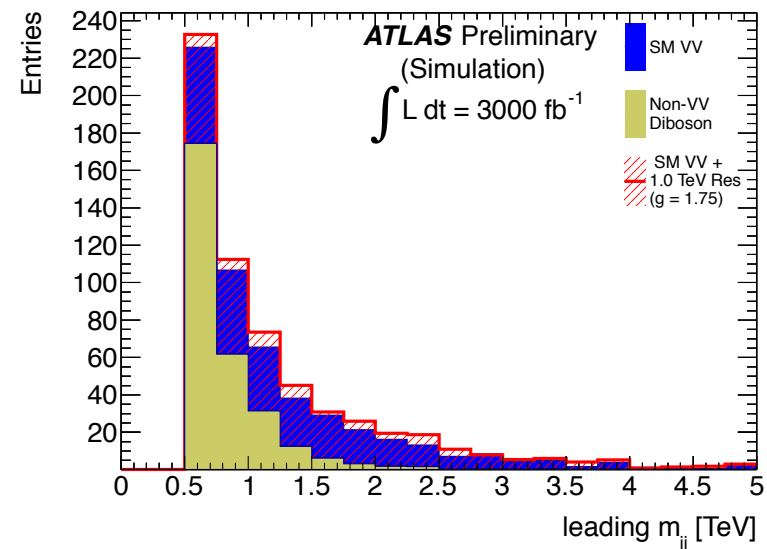
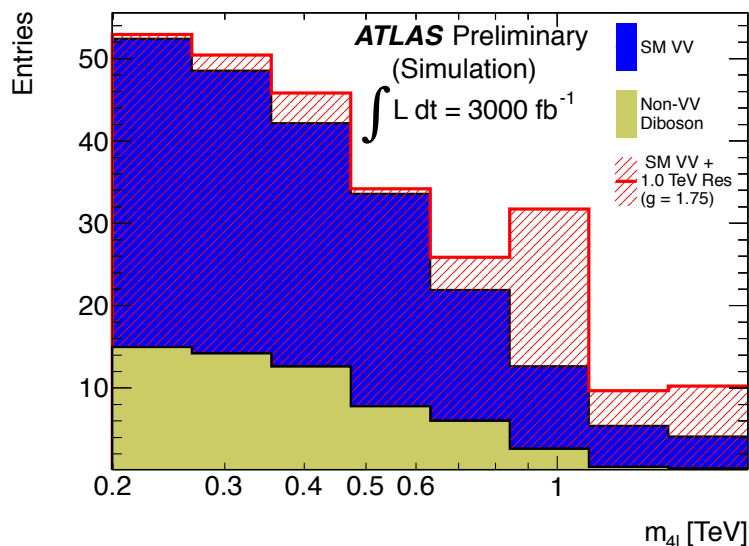

Vector Boson Scattering

- At LHC VBS are tagged with two forward high- p_T jets on either side, the remnants of the quarks that have emitted the W/Z bosons in the central rapidity region: WW+2jets, WZ+2jets, ZZ+2jets
- ATLAS has performed preliminary studies of the process $pp \rightarrow ZZjj \rightarrow 4l+jj$ within the “Pade” unitarization (IAM, Inverse Amplitude Method) and using the WHIZARD generator (it allows to generate weak boson scattering mediated by a new high-mass resonance in presence of a Higgs boson with 126 GeV mass)

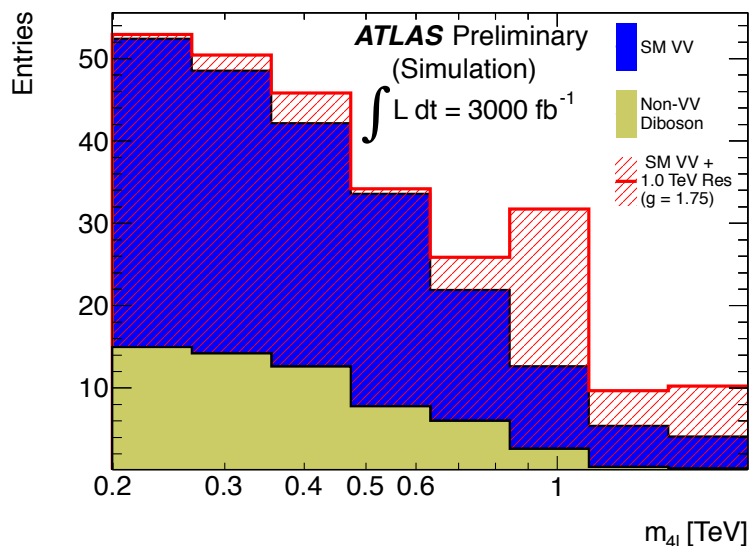

model	300 fb^{-1}	3000 fb^{-1}
$m_{\text{resonance}} = 500 \text{ GeV}, g = 1.0$	2.4σ	7.5σ
$m_{\text{resonance}} = 1 \text{ TeV}, g = 1.75$	1.7σ	5.5σ
$m_{\text{resonance}} = 1 \text{ TeV}, g = 2.5$	3.0σ	9.4σ

Summary of the expected sensitivity to anomalous VBS signal for a few values of the mass of the resonance and of the coupling g .

SUSY Searches

- So far there has been no sign of Supersymmetry at LHC
 - However only $< 10\%$ of the LHC expected data have been studied (and at $\sqrt{s}=7$ TeV)
 - 3rd generation squarks have low cross-sections
- If we find it:
 - We have a large set of new particles to study
 - Thus a SUSY discovery will mandate more luminosity
- If will not find it by 2020:
 - HL-LHC offers a 25% increase in mass reach
 - HL-LHC will explore a phase space no other machine will probe for decades

Searches for stop

ATL-PHYS-PUB-2013-001

- Probably this will be one of the most important points in SUSY for the immediate future: naturalness requires stop mass not larger than ~ 1 TeV
- Rates will be modest \rightarrow HL-LHC represents an ideal machine for this search

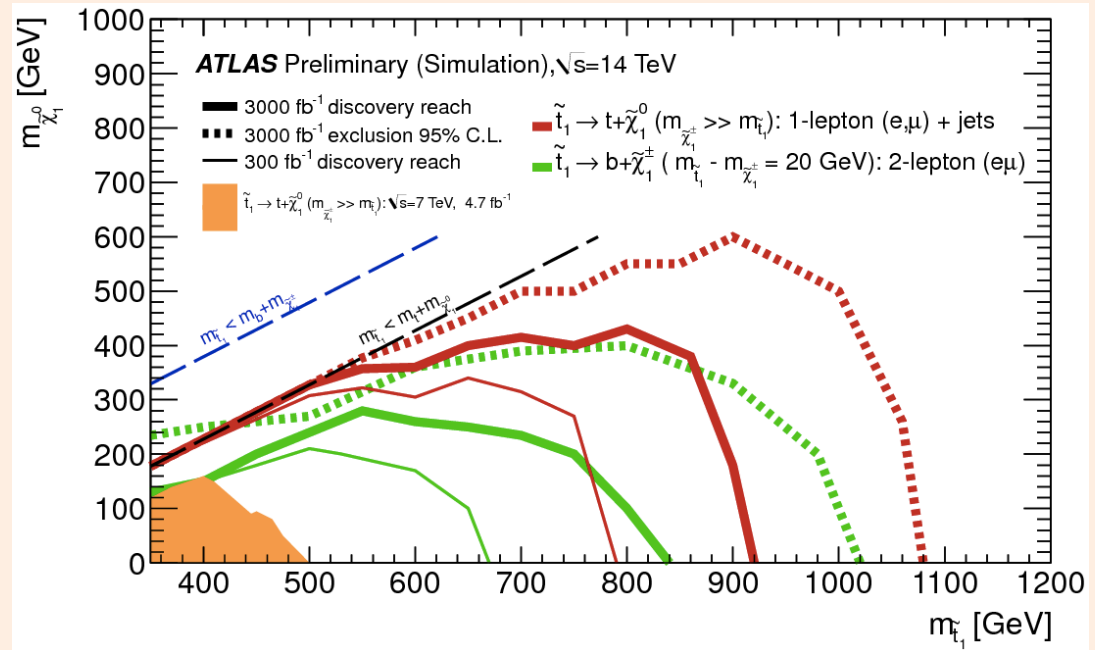

The 95% CL exclusion limits for 3000 fb^{-1} (dashed) and 5 sigma discovery reach (solid) for 300 fb^{-1} and 3000 fb^{-1} in the stop, neutralino_1 mass plane assuming:

- $\tilde{t}_1 \rightarrow t + \tilde{\chi}_1^0$ ($m_{\tilde{\chi}_1^0} \gg m_{\tilde{t}_1}$): 1-lepton (e, μ) + jets
- $\tilde{t}_1 \rightarrow b + \tilde{\chi}_1^\pm$ ($m_{\tilde{t}_1} - m_{\tilde{\chi}_1^\pm} = 20$ GeV): 2-lepton (e μ)

Searches for squarks and gluinos

ATL-PHYS-PUB-2013-001

- HL-LHC gives tight limits:
 - ~ 3 TeV for squarks
 - ~ 2.5 TeV for gluinos
- This represents a 400 GeV rise in sensitivity with respect to the $L=300$ fb^{-1} case

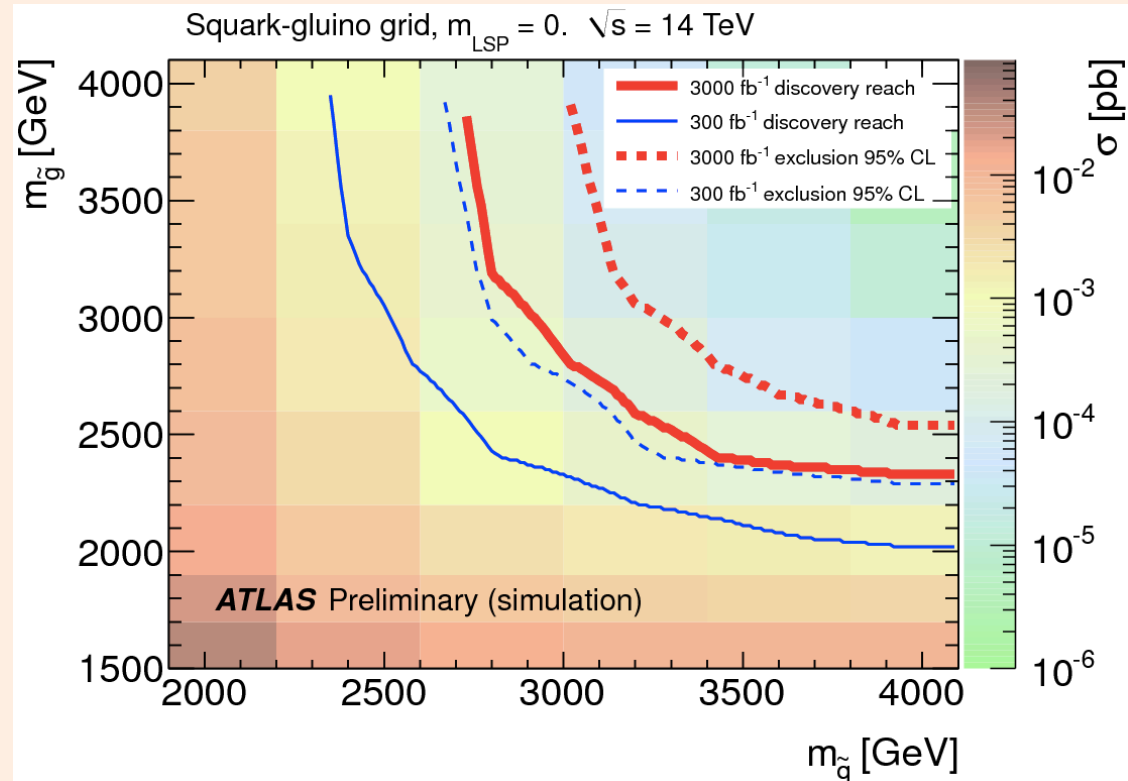

The 95% CL exclusion limits (solid lines) and 5 sigma discovery reach (dashed lines) in a simplified squark--gluino model with massless neutralino with 300 fb^{-1} (blue lines) and 3000 fb^{-1} (red lines). The colour scale shows $\sqrt{s}=14$ TeV NLO production cross section calculated by Prospino 2.1.

Exotics Searches

ATL-PHYS-PUB-2013-003

- Searches for $t\bar{t}$ resonances or Z' leptons can exploit the physics potential offered by HL-LHC

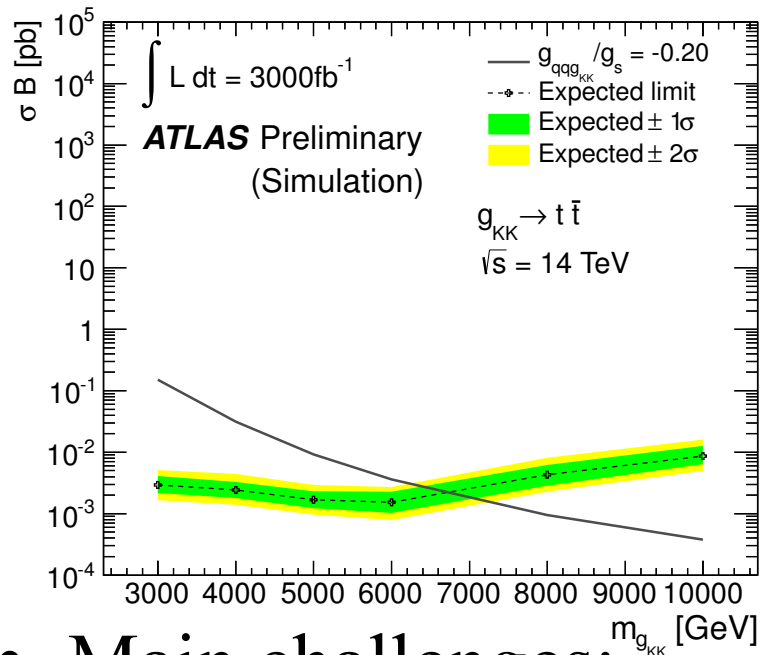

model	300 fb ⁻¹	1000 fb ⁻¹	3000 fb ⁻¹
g_{KK}	4.3 (4.0)	5.6 (4.9)	6.7 (5.6)
$Z'_{\text{Topcolour}}$	3.3 (1.8)	4.5 (2.6)	5.5 (3.2)
$Z'_{SSM} \rightarrow ee$	6.5	7.2	7.8
$Z'_{SSM} \rightarrow \mu\mu$	6.4	7.1	7.6

Summary of the expected limits for $g_{KK} \rightarrow t\bar{t}$ and $Z'_{\text{Topcolour}} \rightarrow t\bar{t}$ searches in the lepton+jets (dilepton) channel and of $Z'_{SSM} \rightarrow ee$ and $Z'_{SSM} \rightarrow \mu\mu$ searches in the Sequential Standard Model. All boson mass limits are quoted in TeV.

- Main challenges:
 - Reconstruct highly boosted top decays
 - Ensure lepton measurement at very high p_T
 - Muon system alignment
 - Leakage from calorimeter (?)

ERICE (Sicily)

Update of the European Strategy for Particle Physics

Roy Aleksan
HF-Frascati
Feb. 14, 2013

Habemus Strategiam!

17 recommendations have been issued:

<https://indico.cern.ch/getFile.py/access?resId=0&materialId=0&confId=217656>

They have still to be endorsed by the CERN Council (March 20).

High-priority large-scale scientific activities

Recommendation #1

c) The discovery of the Higgs boson is the start of a major programme of work to measure this particle's properties with the highest possible precision for testing the validity of the Standard Model and to search for further new physics at the energy frontier. The LHC is in a unique position to pursue this programme. *Europe's top priority should be the exploitation of the full potential of the LHC, including the high-luminosity upgrade of the machine and detectors with a view to collecting ten times more data than in the initial design, by around 2030. This upgrade programme will also provide further exciting opportunities for the study of flavour physics and the quark-gluon plasma.*

High-priority large-scale scientific activities

Recommendation #2

d) To stay at the forefront of particle physics, Europe needs to be in a position to propose an ambitious post-LHC accelerator project at CERN by the time of the next Strategy update, when physics results from the LHC running at 14 TeV will be available. *CERN should undertake design studies for accelerator projects in a global context, with emphasis on proton-proton and electron-positron high-energy frontier machines. These design studies should be coupled to a vigorous accelerator R&D programme, including high-field magnets and high-gradient accelerating structures, in collaboration with national institutes, laboratories and universities worldwide.*

High-priority large-scale scientific activities

Recommendation #3

e) There is a strong scientific case for an electron-positron collider, complementary to the LHC, that can study the properties of the Higgs boson and other particles with unprecedented precision and whose energy can be upgraded. The Technical Design Report of the International Linear Collider (ILC) has been completed, with large European participation. The initiative from the Japanese particle physics community to host the ILC in Japan is most welcome, and European groups are eager to participate. *Europe looks forward to a proposal from Japan to discuss a possible participation.*

Conclusions (HL-LHC)

- A data sample of 300 fb^{-1} at the LHC will allow to exclude strong deviations of the Higgs-like particle recently discovered from the Higgs boson predicted by Standard Model
- A complete investigation on the physics properties of this new boson will require the search for rare decay final states, selfcoupling processes, CP violation effects, as well as the reduction of experimental (and theoretical) uncertainties → High-Luminosity LHC with $L=3000 \text{ fb}^{-1}$ can provide the required statistics with an accuracy on the Higgs couplings in the range of 1-4%;
- HL-LHC extends the searches of LHC of BSM physics, and offers the required data to study the properties of new particles if found at the LHC

The LHC → HL-LHC Upgrade

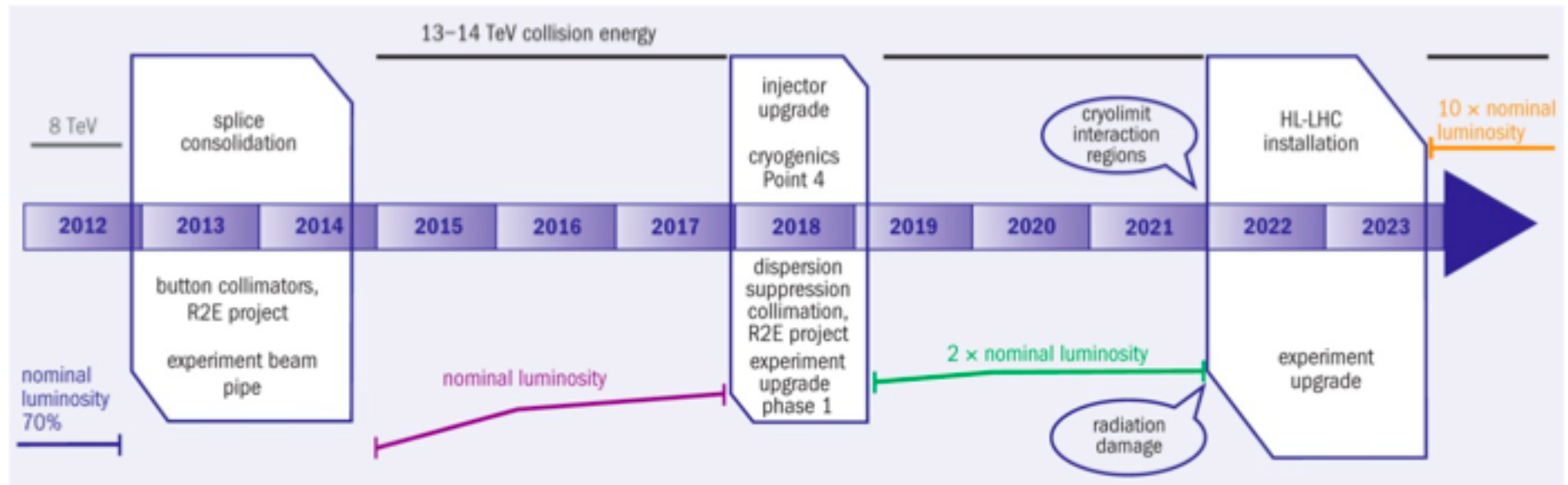

Figure 1: LHC baseline plan for the next ten years. In terms of energy of the collisions (upper line) and of luminosity (lower lines). The first long shutdown 2013-14 is to allow design parameters of beam energy and luminosity. The second one, 2018, is for secure luminosity and reliability as well as to upgrade the LHC Injectors.

The LHC \rightarrow HL-LC Upgrade

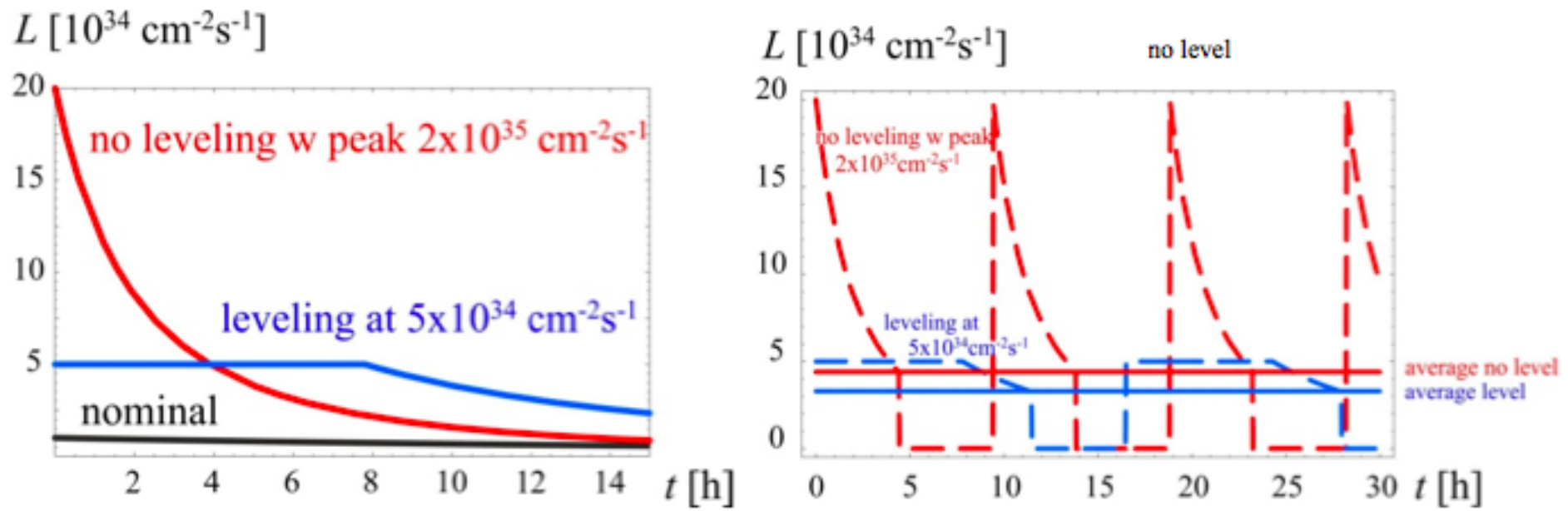

Figure 2.3: Left: luminosity profile for a single long run starting at nominal peak luminosity (black line), with upgrade no levelling (red line) with levelling (dotted line). Right: luminosity profile with optimized run time, without and with levelling (blue and red dashed lines), and average luminosity in both cases (solid lines).

The LHC → HL-LHC Upgrade

Table 2. Summary of the cost of HL-LHC with split between Consolidation and full performance.

	Improving Consolidation	Full performance	Total HL-LHC
Mat. (MCHF)	476	360	836
Pers. (MCHF)	182	31	213
Pers. (FTE-y)	910	160	1070
TOT (MCHF)	658	391	1,049

The European Strategy Preparatory Group

52

R. Aleksan, P. Braun-Munzinger, Ph. Chomaz, K. Desch, C. De Clercq,
M. Diemoz, K. Huitu, P. Jenni, M. Krammer, Y. Kuno,
P. McBride, T. Nakada, E. Tsesmelis, D. Wark, A. F. Żarnecki,
and F. Zwirner

European Strategy for Particle Physics Preparatory Group

and

P. Brun, E. Fernandez Martinez, R. Forty, E. Garutti, K. Kutak,
A. Lister, P. Slavich, and F. Zimmermann

Scientific Secretaries for the Open Symposium in Cracow, Poland

From ν -factories toward the “dream” of muon collider

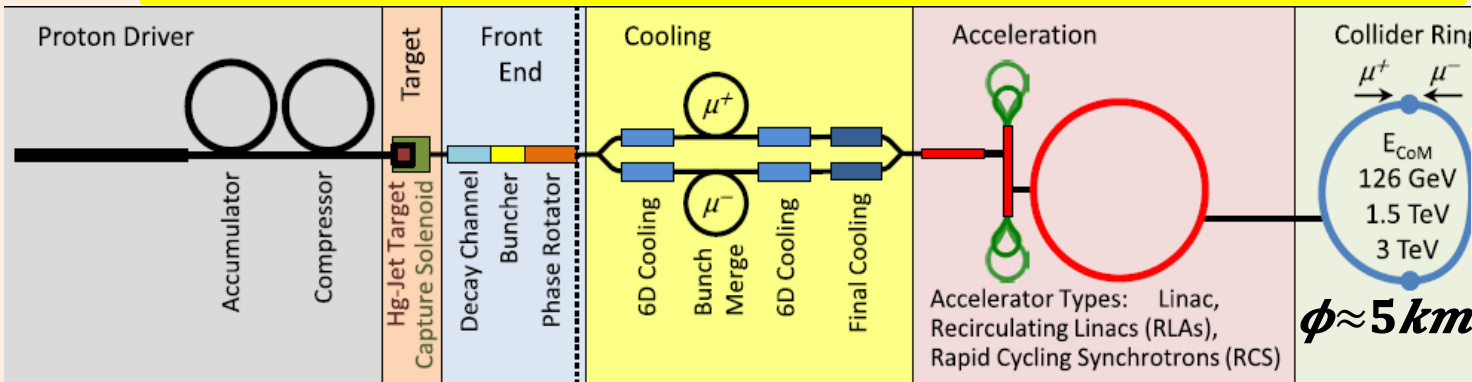

Some ultra-challenging components:

- Very high field solenoids (>30T)
- High gradient cavities in multi-Tesla field

Require much smaller beam size (i.e. lower emittance)
Very efficient cooling →

Recommendations from European Strategy Group (cont'd)

High-priority large-scale scientific activities

Recommendation #4

f) Rapid progress in neutrino oscillation physics, with significant European involvement, has established a strong scientific case for a long-baseline neutrino programme exploring CP violation and the mass hierarchy in the neutrino sector. *CERN should develop a neutrino programme to pave the way for a substantial European role in future long-baseline experiments. Europe should explore the possibility of major participation in leading neutrino projects in the US and Japan.*

Higgs couplings for Precision Higgs Factories

- Same conclusion when Γ_H is a free parameter in the fit
 - Plot shown only for ILC350 and TLEP, with an accurate width measurement

$$\sigma_{HZ} \propto g_{HZZ}^2, \text{ and } \sigma_{HZ} \times \text{BR}(H \rightarrow XX) \propto g_{HZZ}^2 g_{HXX}^2 / \Gamma_H$$

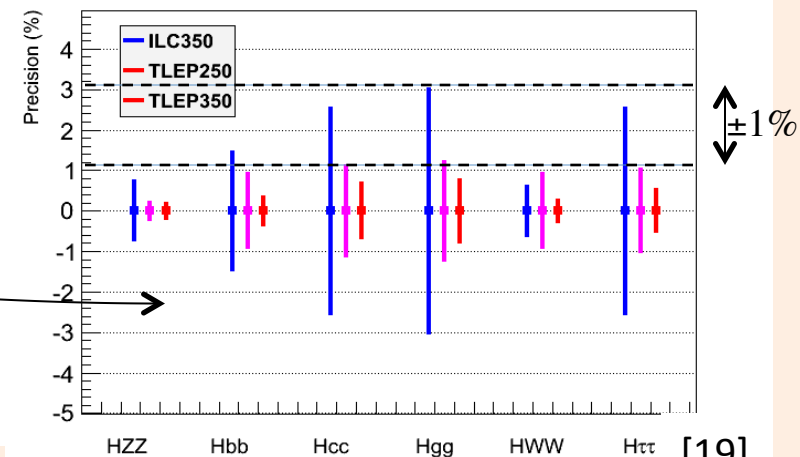
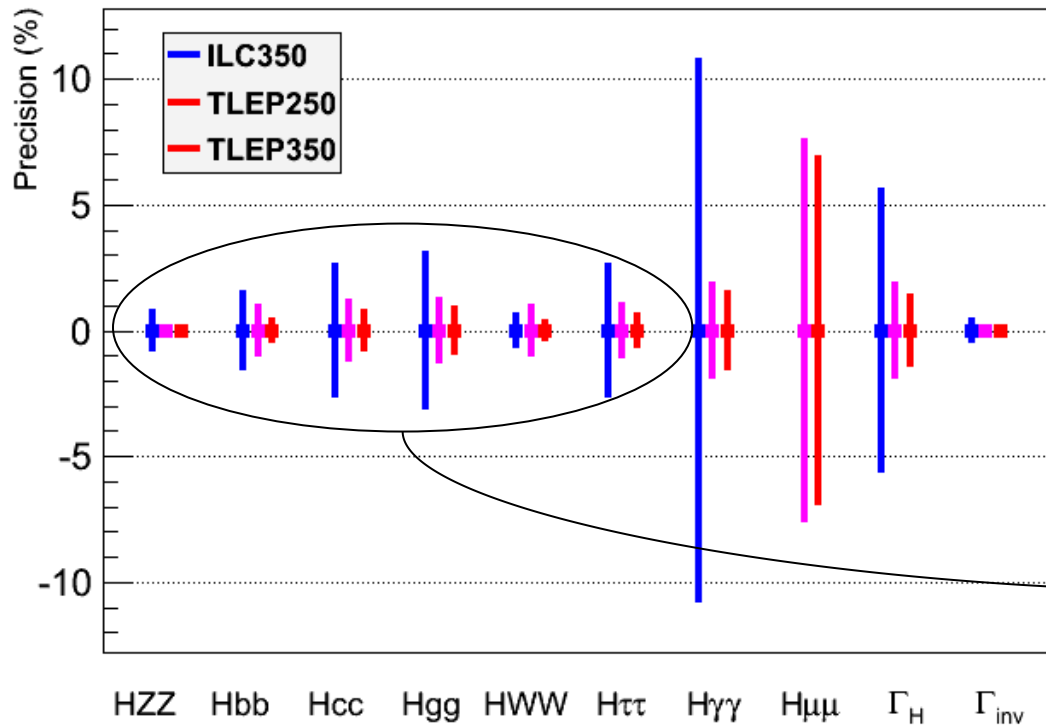

[19]

TLEP : sub-percent precision, adequate for NP sensitivity beyond 1 TeV

by Patrick Janot