

---

# The 2013 CERN-Latin-American School of High-Energy Physics

## Arequipa, Peru (6–19 March 2013)

# LHC Results Highlights

## (Lecture I: Introduction and SM Physics)

**Óscar González (CIEMAT)**





These lectures are intended to cover the most relevant and interesting results on the physics at the LHC Experiments.

They are structured as follow:

- **Lecture I covers the description of the experiments and SM-related results.**
  - ⇒ The theoretical context for the LHC
  - ⇒ The experimental setup: The LHC, the experiments and tools
  - ⇒ Results on soft and jet physics (QCD)
  - ⇒ EWK boson and diboson production
  - ⇒ Flavour physics measurements and results
- **Lecture II covers the results related to the general goals of the experiments.**  
**Heavy-Ions, Top Physics and searches of Supersymmetric particles.**
- **Lecture III covers the results on Higgs and New Physics**  
**Searches of the Higgs and New Physics (except SUSY).**

**CAVEAT: I have tried to show the most up-to-date results, but this may not be always the case, specially in these days and the updates for the Winter Conferences. This also applies to the quoted references.**



# The Theoretical Context at the LHC Era

# The Standard Model (in one slide)



- The Standard Model (SM) of particles and interaction is **the most successful theory to describe Nature at the smallest scales (or highest energies).**

- Three families of fermions describe “matter”

- Interactions are described by the symmetry group

$$SU(3)_C \times SU(2)_L \times U(1)_Y$$

but in Nature the  $SU(2)_L \times U(1)_Y$  appears as a broken symmetry giving rise to the weak and electromagnetic interactions.

- Symmetry spontaneously broken by an additional (Higgs) field via the BEH mechanism

In the process  $W$  and  $Z$  get mass,  $\gamma$  remains massless and one degree of freedom should appear as scalar boson whose properties are known except for the mass.

- As an addition, fermions get their masses by the interaction with this field, **since previous symmetry group prevent particles having inertial mass.**

Three Generations of Matter (Fermions)

	I	II	III	
mass→	2.4 MeV	1.27 GeV	171.2 GeV	0
charge→	$\frac{2}{3}$	$\frac{2}{3}$	$\frac{2}{3}$	0
spin→	$\frac{1}{2}$	$\frac{1}{2}$	$\frac{1}{2}$	1
name→	<b>u</b> up	<b>c</b> charm	<b>t</b> top	<b>γ</b> photon
	4.8 MeV	104 MeV	4.2 GeV	0
	$-\frac{1}{3}$	$-\frac{1}{3}$	$-\frac{1}{3}$	0
	$\frac{1}{2}$	$\frac{1}{2}$	$\frac{1}{2}$	1
Quarks	<b>d</b> down	<b>s</b> strange	<b>b</b> bottom	<b>g</b> gluon
	<2.2 eV	<0.17 MeV	<15.5 MeV	91.2 GeV
	0	0	0	0
	$\frac{1}{2}$	$\frac{1}{2}$	$\frac{1}{2}$	1
	<b>ν<sub>e</sub></b> electron neutrino	<b>ν<sub>μ</sub></b> muon neutrino	<b>ν<sub>τ</sub></b> tau neutrino	<b>Z</b> weak force
Leptons	0.511 MeV	105.7 MeV	1.777 GeV	80.4 GeV
	-1	-1	-1	$\pm 1$
	$\frac{1}{2}$	$\frac{1}{2}$	$\frac{1}{2}$	1
	<b>e</b> electron	<b>μ</b> muon	<b>τ</b> tau	<b>W</b> weak force

Bosons (Forces)

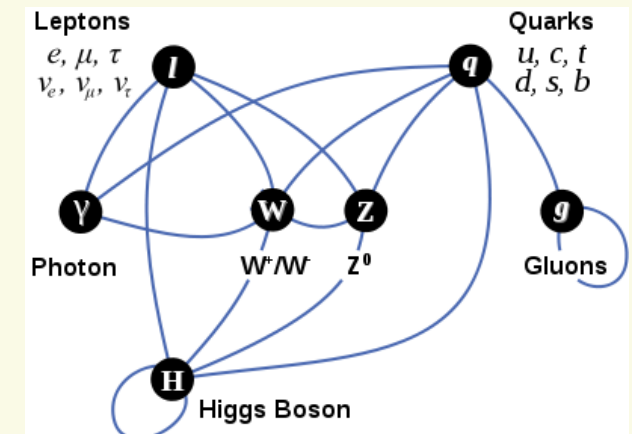

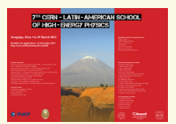

Even if no competitor for the SM, several established observations are not described by the model:

⇒ **Masses of the neutrinos**

(Oscillations in many (dis-)appearance experiments)

⇒ **Existence of a matter-dominated Universe**

(The measured CP violation is NOT enough to explain the actual imbalance)

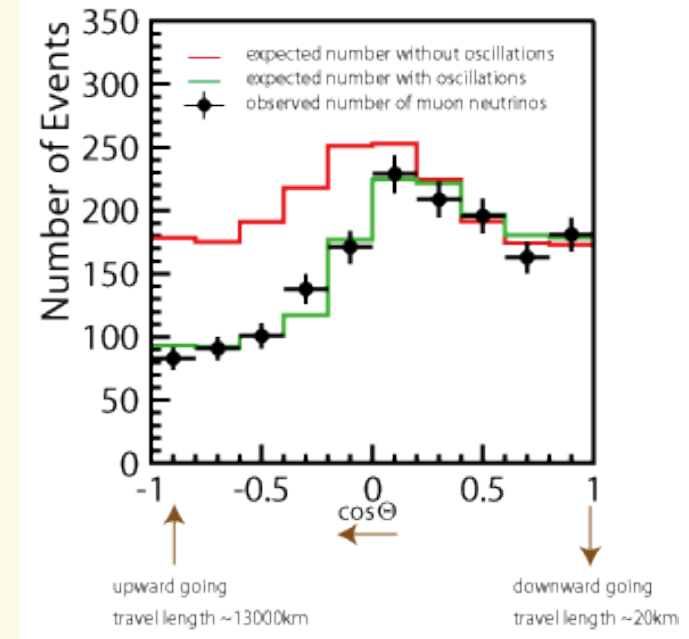

In fact, Universe as we see cannot be explained by the SM... and only partially described:

⇒ **Gravity (Cosmology-related stuff) is MISSING:**

- **Not even considered as interaction in the SM**  
 (Too weak at the current reachable energy scales)
- **Dark Matter: is it a (weakly-interacting) particle?**  
 (No candidate within the SM spectrum)
- **Dark Energy?**

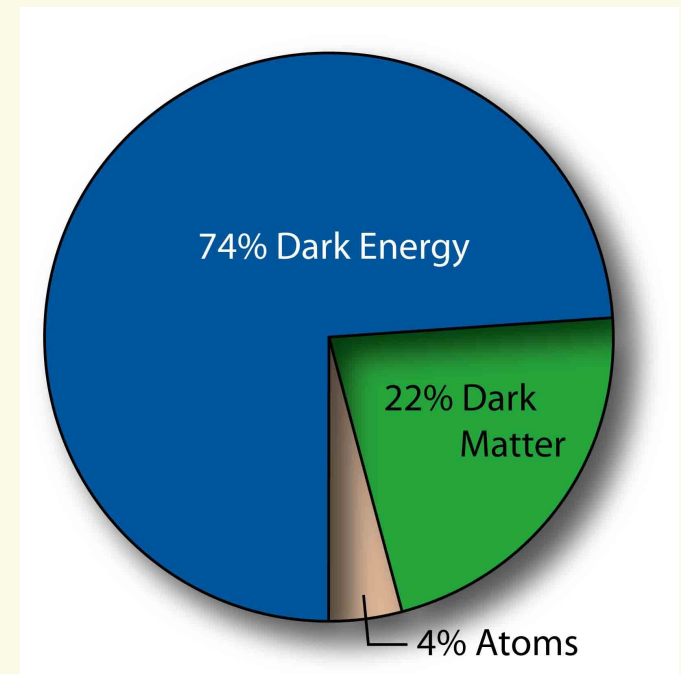



From the theoretical side there are also weak points of the theory that clearly suggests something else should appear at some energy.

- The Hierarchy problem.
- Close-to Unification of interactions.
- Why three families?
- Why families contain “double-nature sets” (quarks and leptons) that appear similar in structure but otherwise unrelated.

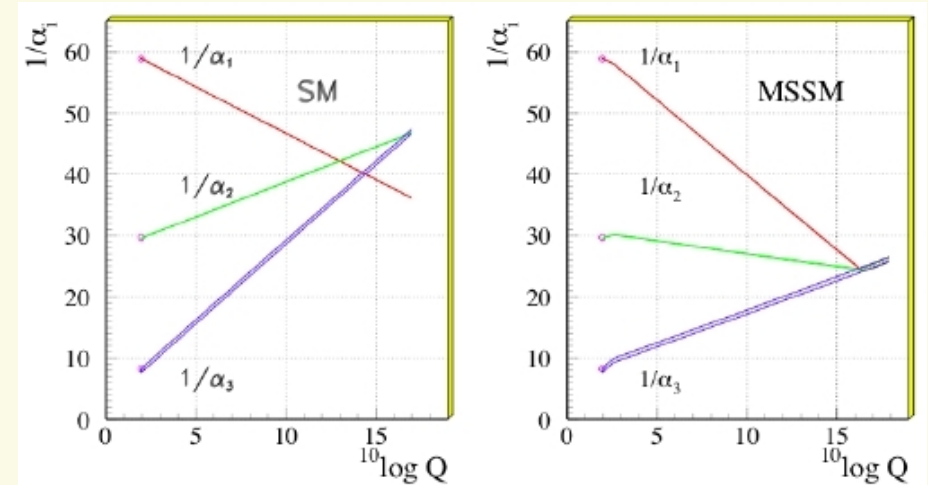

- Where is the CP violation needed for the disappeared antimatter?
- Too much fine tuning in many places: **lack of naturalness.**

And in summary:

- ⇒ Too many free parameters (i.e. unexplained origin/source of quantities/values).
- ⇒ Too many missing things.



- Even if it does not look at first sight, **the experimental limitations and the theoretical issues are closely related.**
- The (simpler) answer is: something beyond the SM appears at higher scales.
- This “New Physics” will show up affecting the measurements. **We expect the higher the scale, the smaller the effect.**
- This includes the possible production of new particles if energy is enough.

**So, we are looking, at least in the simpler approach, for:**

- ⇒ Presence of new massive particles
- ⇒ or weakly interacting particles (hard to produce, hard to detect)
- ⇒ Deviations in difficult measurements (hard-to-produce final states)
- ⇒ or very precise quantities
- ⇒ Exotic (and rare) processes or final states.

**Of course, Nature is not simple, so this may bring a misleading outcome.**

**Still, it is clear that pursuing these goals will help us to go beyond the previous knowledge since we will be exploring areas that were not studied previously.**



- A collider with an energy higher than that previously available provides **the best place to look for the effects of the “New Physics”** (specially for the production of **New Physics**).
- A proton-proton collider has several advantages regarding the needs, from the technological point of view:
  - ⇒ **Very large available energy (i.e. wrt lepton collider)**
  - ⇒ **Large statistics for studying rare processes (i.e. wrt proton-antiproton)**
- A hadron collider has also **a few drawbacks** (initial state not clean, hard-process energy not well defined or known,...) but they are **not that relevant for discovery, and even for important measurements** (as History teaches us).
- What the world needs now...
  - a discovery machine: tons of energy and tons of data.**

A large hadron collider would satisfy these requirements and provide the possibility to reach the physics beyond the Standard Model.

And it requires to be complemented with the appropriate detectors to exploit the possibilities showing up from the collisions.



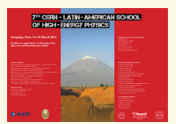

# The LHC and the Experiments



- Most energetic (and most challenging) collider in the World and History.
- Collides protons (or heavy ions, as lead) at several TeV

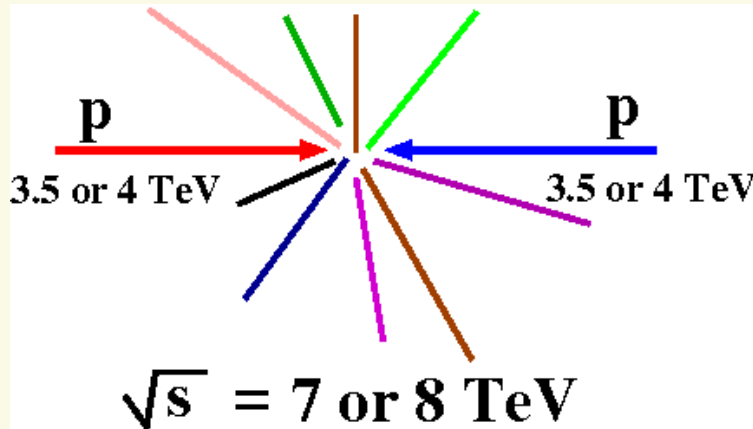

Designed for 14 TeV, it needs some work to reach those values. For the results discussed here:

- Run at 7 TeV from March 2010 to December 2011
- Run at 8 TeV from April 2012 to February 2013
- Shutdown starting in 2013 to get full energy

Current data samples are able to reach energy scales that were never accessed before, in both particle and Heavy-Ion physics.

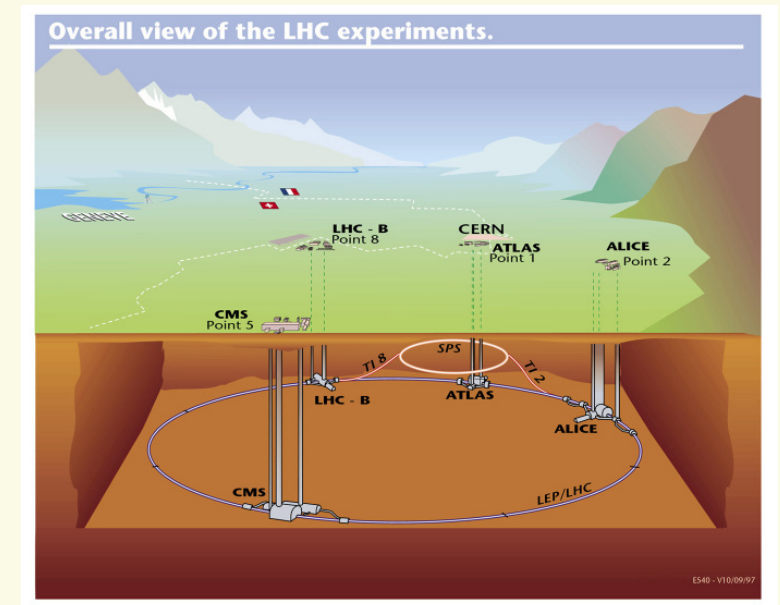



- The LHC is not only about energy, but also about amount of collisions (events).
- To quantify the amount of events collected, one uses the concept of “luminosity”

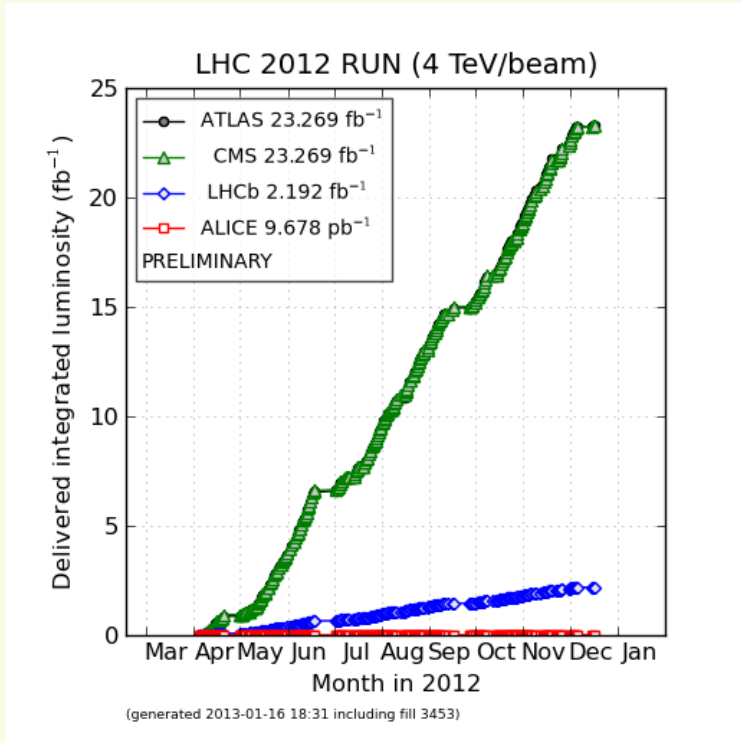

$$L = \int F \cdot \frac{N_1 N_2}{4\pi\sigma_x\sigma_y\Delta t} dt$$

	p-p	Pb-Pb	p-Pb
2010 Run (7 TeV)	50 pb <sup>-1</sup>	9 μb <sup>-1</sup>	–
2011 Run (7 TeV)	6 fb <sup>-1</sup>	160 μb <sup>-1</sup>	–
2012 Run (8 TeV)	23.3 fb <sup>-1</sup>	–	–
2013 Run (8 TeV)	–	–	32 nb <sup>-1</sup>

Although a technical parameter, in practical terms, one can use the relation between the luminosity ( $L$ ), the cross section of any given process ( $\sigma$ ) and the number of times that such process has (should have) been produced ( $N$ ):

$$L = N/\sigma$$

**calibrating**

$$\sigma = N/L$$

**measuring**

$$N = \sigma \cdot L$$

**predicting**

In the LHC: four points where the protons collide.

Four large collaborations have detectors located at those points to study the final states of the collisions:

These collaborations collect the data from the collisions and analyze them to provide the physics results.

Although I will cover just results from the main 4 experiments, other 3 experiments are doing physics at the LHC:

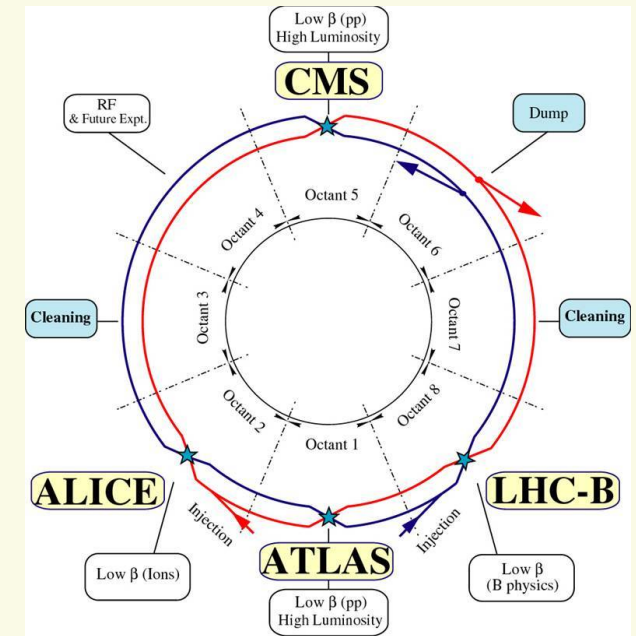

- **TOTEM** (<http://totem.web.cern.ch/Totem/>)

Measurements of  $pp$  total cross section and studies of elastic and diffractive physics at LHC.

Helps in luminosity calibrations and forward physics (with CMS)

- **LHCf** (<http://www.stelab.nagoya-u.ac.jp/LHCf/LHCf/index.html>)

Study of the neutral-particle production in the very forward region of LHC interactions.

Will help to understand atmospheric showers induced by cosmic rays

- **MoEDAL** (<http://moedal.web.cern.ch/>)

Direct search for Magnetic Monopole (Dyons) and highly ionizing (pseudo)stable massive particles.

Data taking starts after current shutdown.

# The ATLAS Experiment

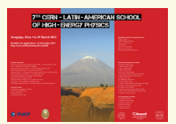

- This is the largest experiment, intended for studying all the possible physics topics analysing the products of the LHC collisions.
- Great capabilities in tracking and calorimetry.
- Forward-backward and azimuthally symmetric, as the physics under study.

- Electron/photon detection
  - ⇒ High granularity and sampling
  - ⇒ Coverage up to  $|\eta| < 2.47$

- Muon detection
  - ⇒ Huge toroids provides precise detection
  - ⇒ Coverage up to  $|\eta| < 3$

- Jets
  - ⇒ Coverage up to  $|\eta| < 4.5$

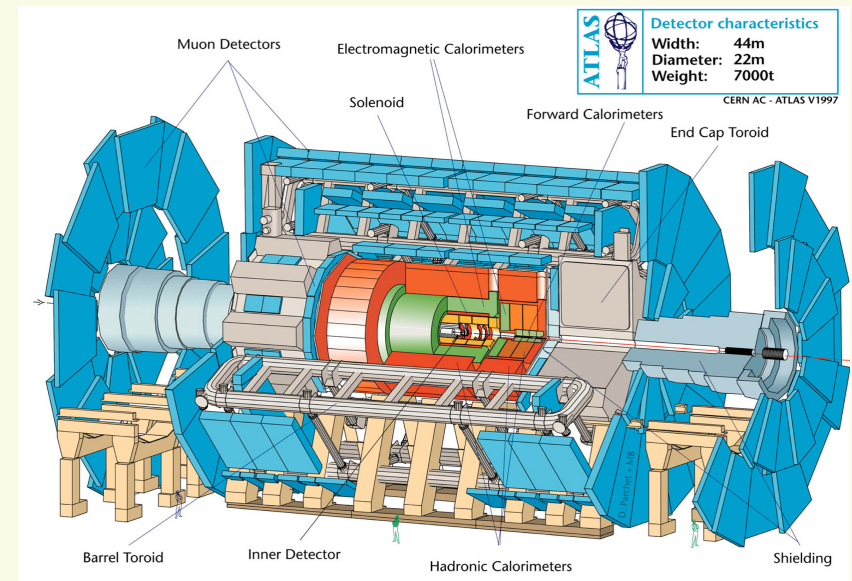

- Its hermetic design allows to infer the presence of undetected particles via the transverse momentum imbalance (see later).

- The pseudorapidity ( $\eta$ ) is a convenient polar-angle variable for hadronic-collisions, which are better described with a cylindrical reference system:

$$\eta = -\ln[\tan(\theta/2)] = \frac{1}{2} \ln \left[ \frac{|p| + p_z}{|p| - p_z} \right]$$



- The other multipurpose detector at the LHC, more compact due to its stronger magnetic field.
- Similar aims and capabilities to ATLAS being more compact.

- **Electron/photon detection**

- ⇒ Impressive energy resolution

- ⇒ Coverage up to  $|\eta| < 2.5$

- **Muon detection**

- ⇒ Redundant with precise inner tracking

- ⇒ Coverage up to  $|\eta| < 2.4$

- **Jets**

- ⇒ Coverage up to  $|\eta| < 4.5$

- The strong point of CMS is the better resolution in inner tracking and redundancy in muon trigger and reconstruction.

- ATLAS has better calorimetry (specially hadronic) and more precise/sophisticated muon detectors.

Differences are more technical than practical... final implementation in analyses provide comparable results.

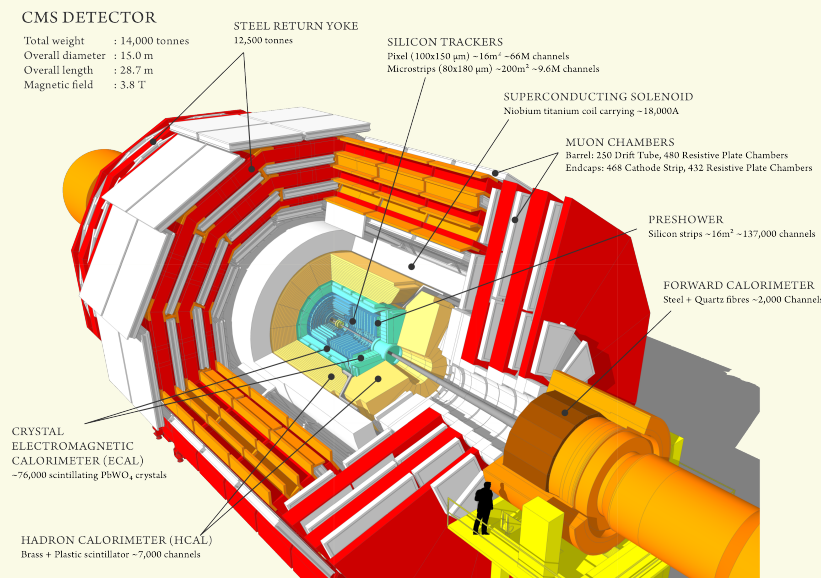

- Mostly intended for B (Heavy-flavour in general) physics studies.
- Requires high rate on B hadrons and very precise tracking and vertexing reconstruction.

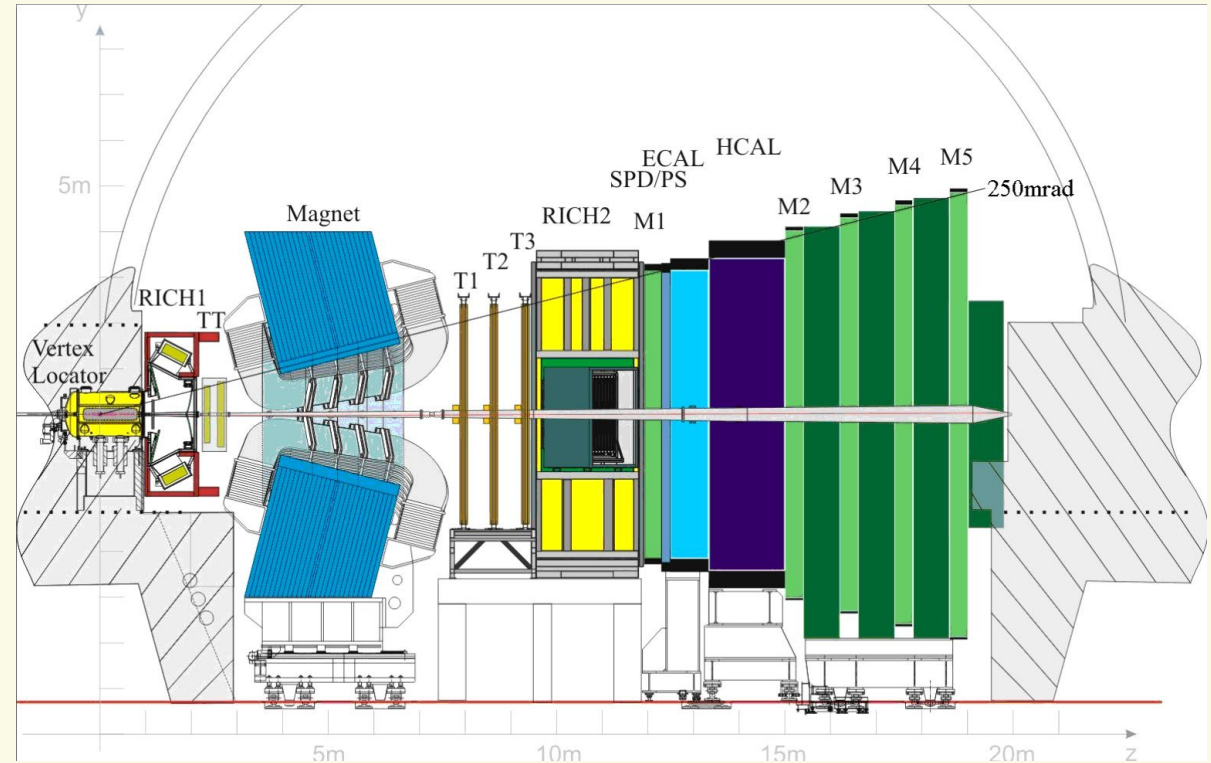
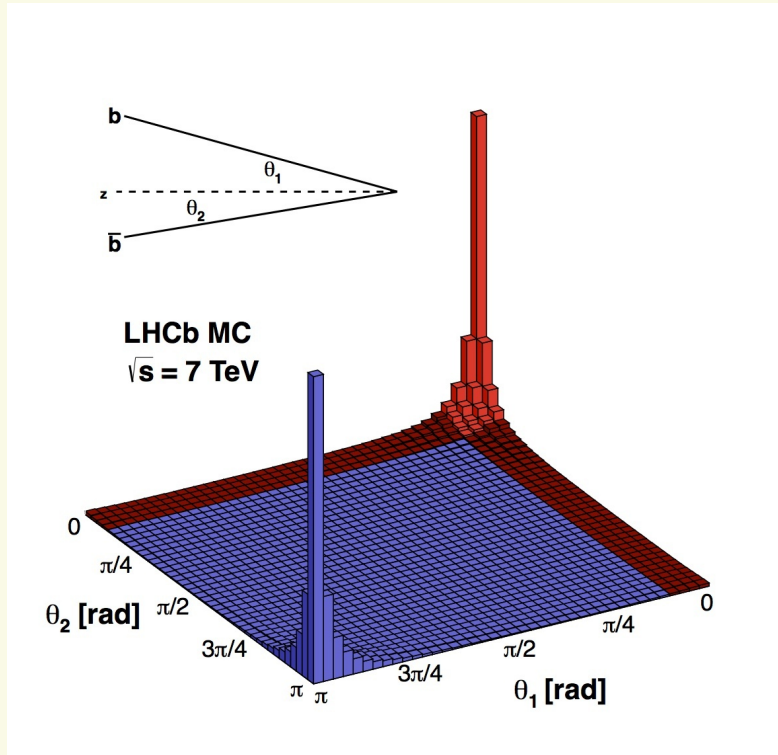

- Very forward detection, for efficient collection of B hadrons.
- Very well suited for the goals:
  - ⇒ Superb track and vertex identification.
  - ⇒ Very good particle identification.
  - ⇒ Reasonable coverage optimized for forward B-hadron products.

- Focused on studying Heavy-Ion collisions.
- Here the aim is not to detect exotic particles or effects, but to study properties of the medium (e.g. quark-gluon plasma?) traversed by known particles.
- Need to identify relevant particles in events which contains a lot of background.
- Although collisions are expected to be symmetric, detector is not symmetric:
  - ⇒ More types of difference subdetectors
  - ⇒ Covering different solid angle regions (e.g. muon detection limited to  $2.5 < \eta < 4$ )
  - ⇒ Able to describe the particle-content of the collisions in great detail.

The strong point of Alice is the impressive particle identification at high densities

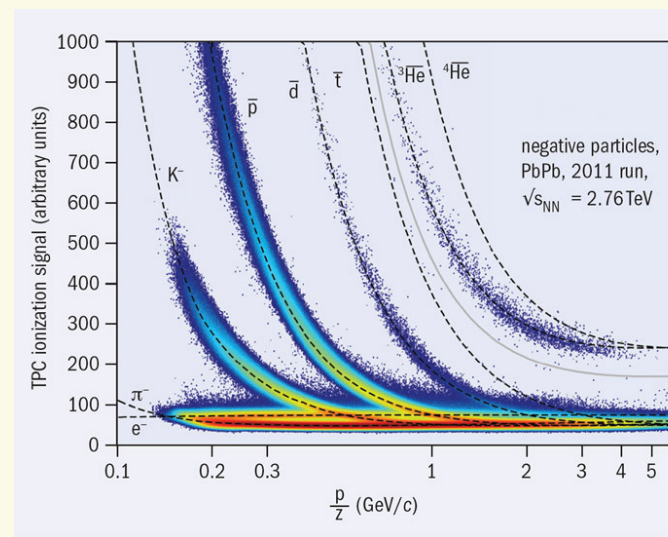
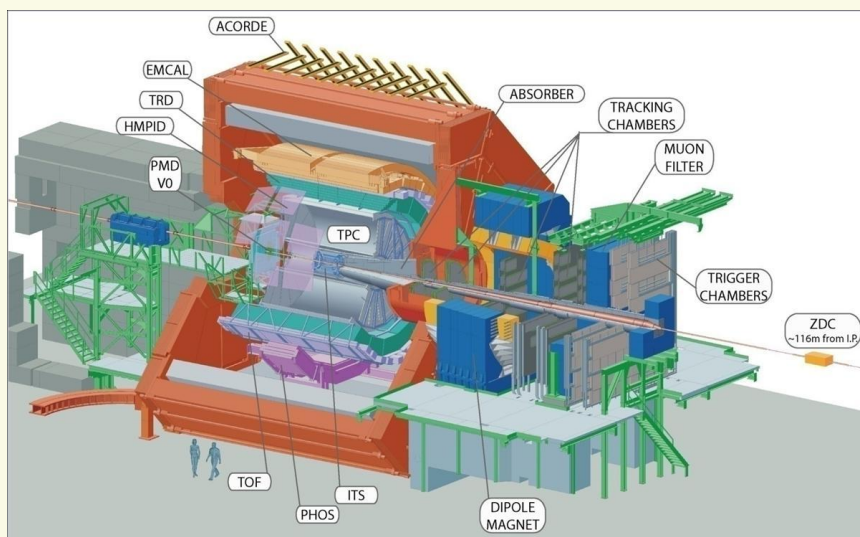

The limitations wrt to ATLAS and CMS is the smaller coverage of the detectors, which gives less acceptance for specific studies (e.g. muons).



The **Data-Acquisition (DAQ)** systems of the experiments are designed to collect the information related to the interesting collisions (events) and store them.

With collisions every 50 ns, we need an automatic computer/electronic-based DAQ system collecting the events and taking decisions about them.

**It is impossible to store all (or part) the information for all the collisions**

The trigger system (ATLAS as example) is **mandatory to perform an automated rejection of non-relevant events.**

⇒ A first step is done with hardware-based processing of the raw information (**rate to  $\sim 100$  kHz**)

⇒ Later steps are based on more or less sophisticated reconstructions (**rate to  $\sim 100$  MB/s, 1 kHz**)

The trigger is the **FIRST** part of the data analysis and it always have a big impact in the results: **events rejected by the trigger are lost forever.**

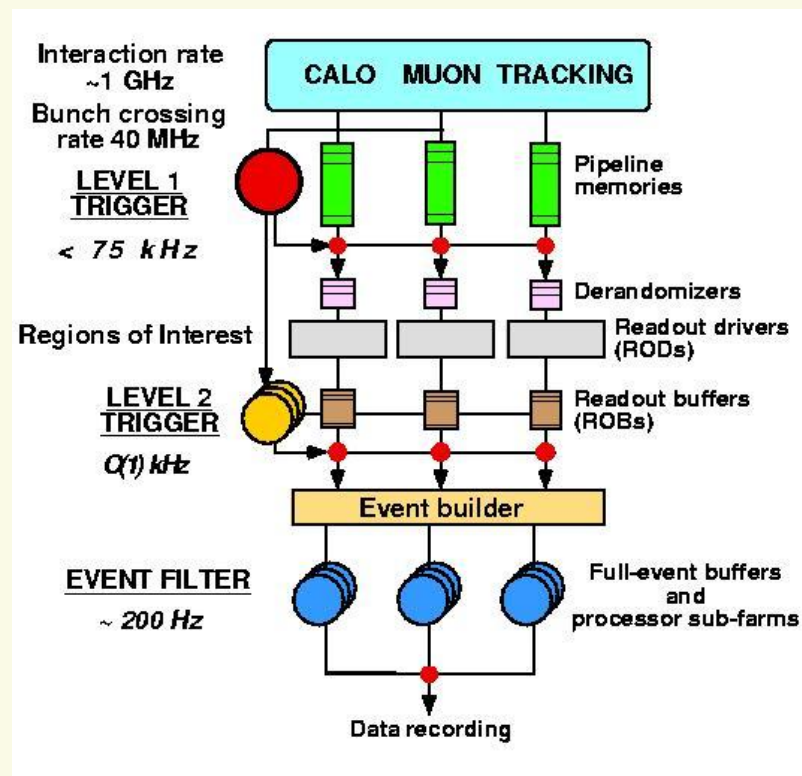



- The triggering context in the LHC experiments represents a new frontier too: **larger, faster, busier...**
- On the other hand, as all of them increases, more interesting physics appear, some of which may be unknown... so **we have to be open-minded and flexible.**
- This is the reason why **at the LHC new concepts for DAQ and trigger has been developed, even on-the-fly, to try to accomodate all the needs:**

⇒ **Data parking/Delayed Data Stream:** take data that is not processed online (current limitation).

**Looser triggers and more inclusive topologies.**

⇒ **Data scouting:** the information for some high-rate events is not stored, except for some small-size final objects.

**Allows to study high-rate samples and content there in, but reprocessing (i.e. improved precision) is not possible.**

**Data-parking allows new results during the shutdown... results with “new data”.**

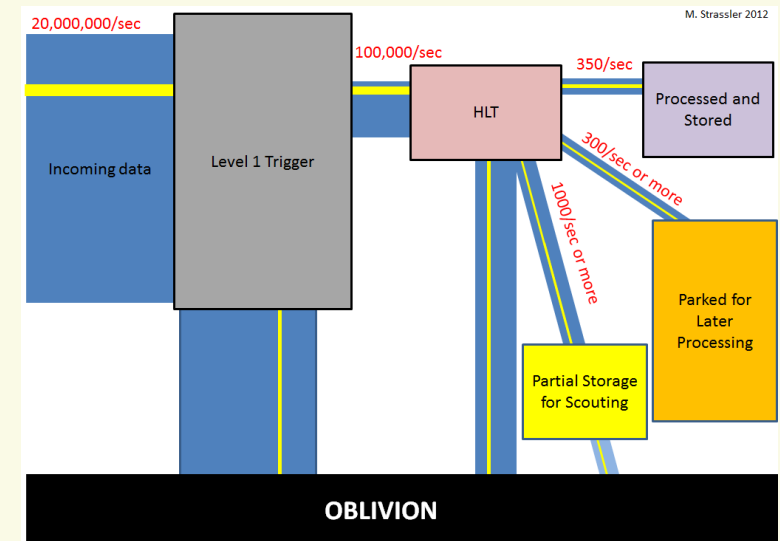



Apart from the issues arising for the actual collection of the data, the high cross section and high luminosities reached at the LHC brings high “pile-up”.

Several pairs of protons collide in a bunch crossing, giving rise to the pile up of collisions in each event.

This introduces challenges at several levels:

- Reconstruction gets confused.
- Harder to distinct interesting events (specially in the trigger).
- inclusive quantities (e.g. MET), badly affected.
- other quantities (jet reconstruction, lepton isolation) very affected also.

The pile-up makes really hard the study of soft events.

This is why LHCb has integrated less luminosity: instantaneous luminosity was smaller to reduce the effect of pile-up (optimal  $\sim 2$  collisions per crossing).

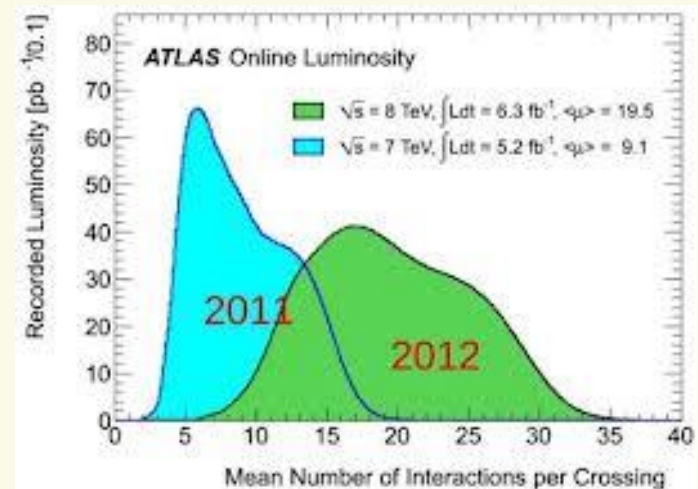
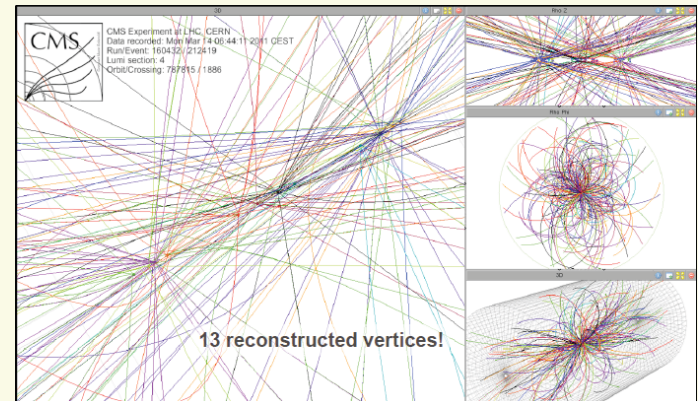
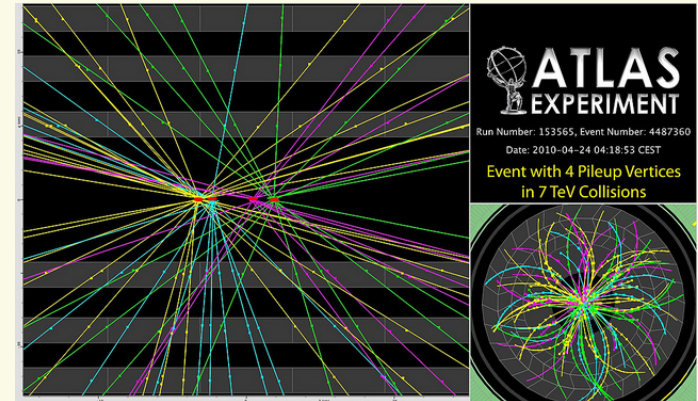



- Electron and muons are easily identified due to their differences wrt hadrons in calorimetry.
- Photons are similar to electrons: EM deposits without track.

Electron and photon reconstruction became harder than expected due to material: need to account with conversions and bremstrahlung in the reconstruction.

A chapter by its own is  $\tau$  identification

- Leptonic reconstruction is usually included as “muon” or “electron”, at least in final states with strong presence of MET.
- The hadronic reconstruction (based on the fact that tau decays are low-multiplicity, low mass mesons) is attractive due to large branching ratio..

- $\tau$  leptons are the hardest objects to identify, but the motivations are very strong due to their possible rôle in the path for New Physics.

We will see a lot of  $\tau$ -based analysis in searches... few in measurements.

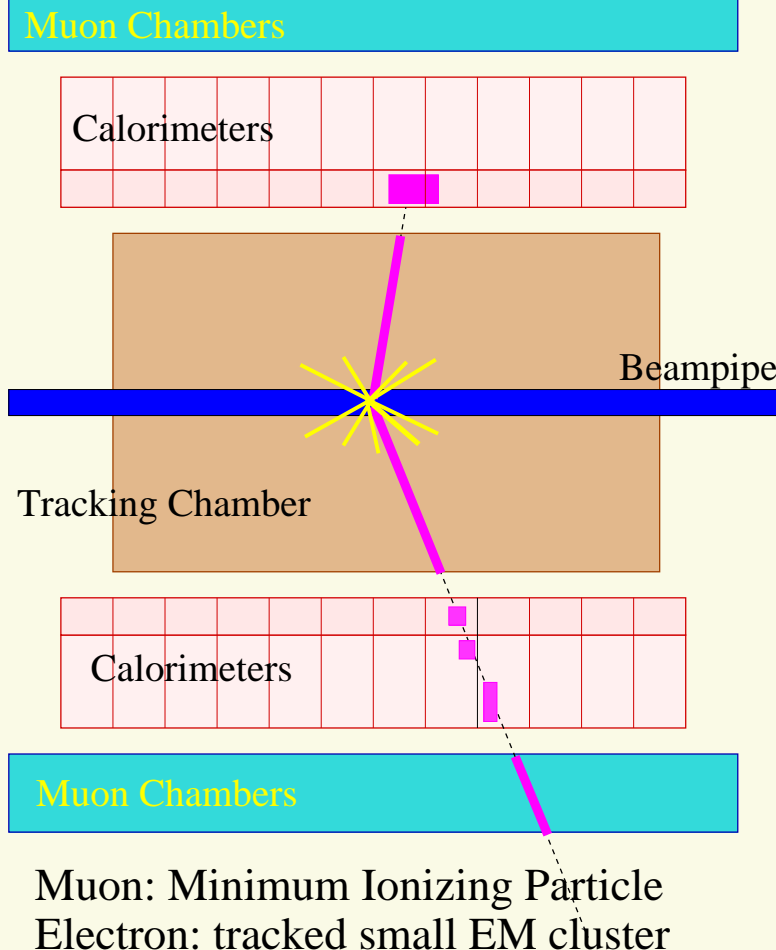



- Quarks and gluons are not observed free in the detectors since the strong force confines them within colourless hadrons.
- Processes leading this are parton showering and hadronization, and they are associated to energy scales of  $\Lambda_{QCD} \sim 0.3 \text{ GeV}$

For hard processes producing partons at several GeV, the dynamics involved make the hadrons being collimated around the parton direction:

This is the reason of associating: **hard partons  $\leftrightarrow$  hadronic jets**

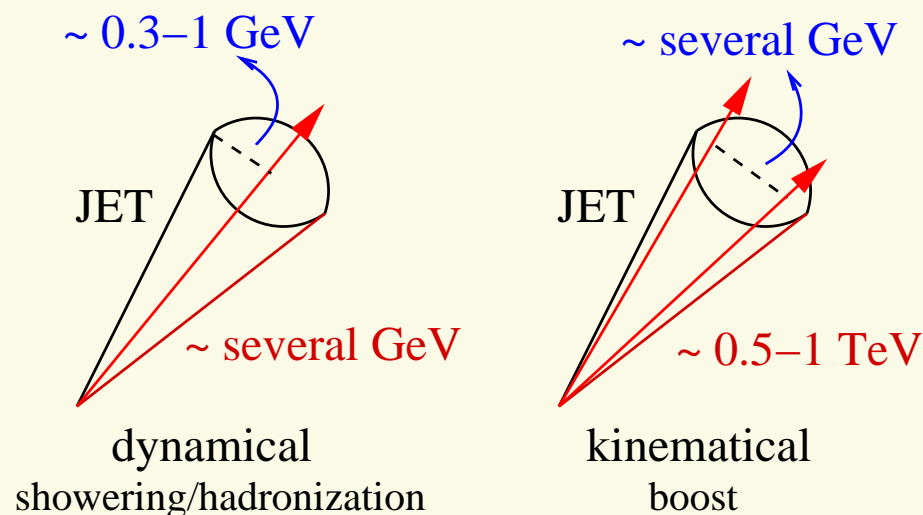

At the LHC, a new ingredient is coming into place: objects produced in processes with many GeV, the separation between objects is small so they are merged within “traditional jets”.

A new field: **improving jet reconstruction to handle object merging.**

Another quantity that is commonly used is the Missing Transverse Energy, which is the transverse momentum imbalance.

$$\text{MET} = \sqrt{[\sum p_x]^2 + [\sum p_y]^2}$$

where the sums run over “particles” for which the MET is computing. Traditionally, calorimeter towers/cells. Today, any kind of object.

Since by momentum conservation we expect this quantity to be small, a large value is interpreted as undetected particles with large  $p_T$ .

**This is how neutrinos are identified!**

Since at the LHC the production of jets (high- $p_T$  partons) is so common, the MET reconstruction is very closely related to the jet topology.

Also very sensitive to all challenges: soft physics, pile-up, mismodeling, ...

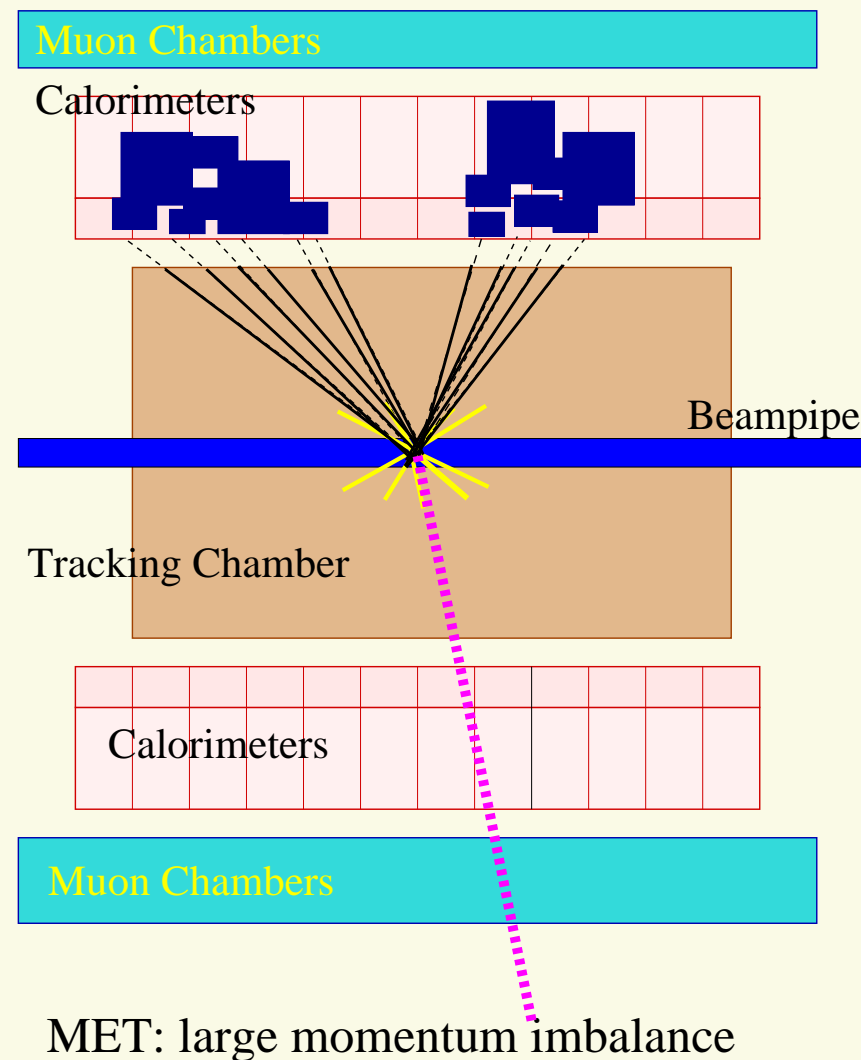



- The LHC detectors and data-analysis are facing new levels of complexity, **new ideas on how to simplify the reconstruction of the objects and the final states.**
- One very popular idea is **the identification of species of particles and use these “objects” instead of the raw quantities** (tracks, calorimeter towers/cells).
- Used for leptons/photons in the past  $\Rightarrow$  **Generalized to charged/neutral hadrons.**

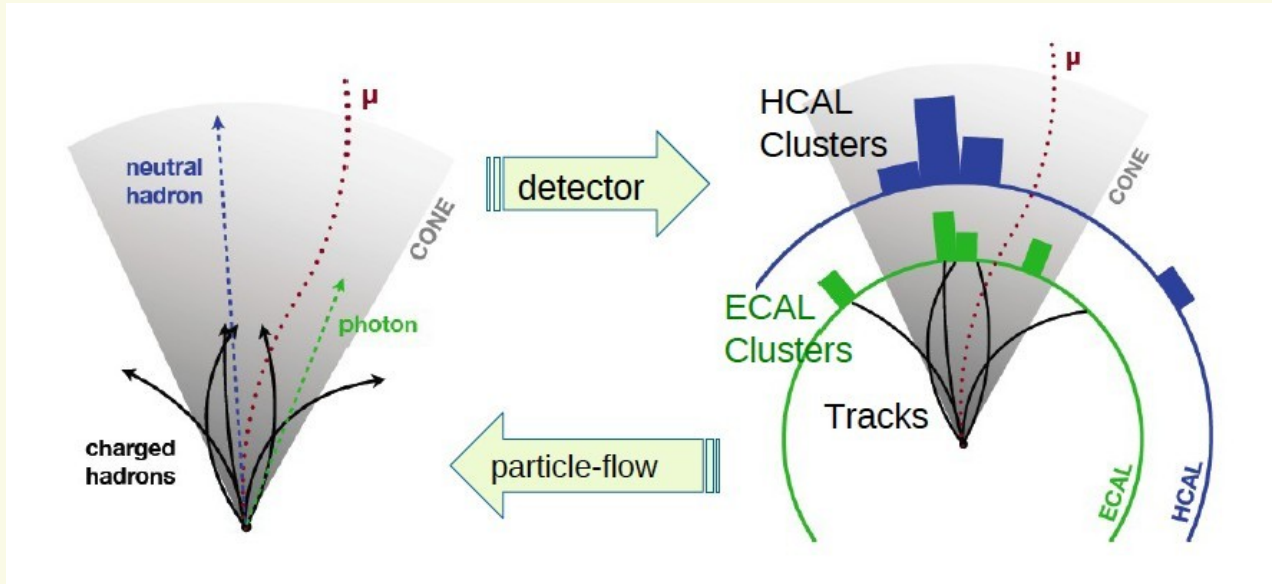

Each particle species is calibrated independently, representing a net gain even if losing the raw information (because that information is used in reconstructing the object).

**CMS put special effort on this that keeps developing today: moving towards a **Global-Event Description** which is fully based on particle flow.**

- It represent a big gain since **it maximizes the usage of information from the tracking and ECAL system**, which have great resolution in momentum and position.

e.g. improving a factor of 2 of the resolution in energy-related quantities with respect to the usage of simple calorimeter information.

# Rediscovering the Standard Model of Particles and Interactions



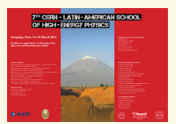

The LHC is a discovery machine: the ultimate goal is to experimentally find the answers to the opening questions regarding fundamental particles and interactions.

The big challenge at the LHC is the huge range of cross sections that needs to be understood:

- Huge cross section for “uninteresting” processes
- Large cross sections for previously known processes
- Medium cross section for not so-well studied processes
- Low cross section for discovery processes

It should be noted that all challenges at LHC are produced exactly for this reason:

- ⇒ Large backgrounds: interesting physics swamped by known processes.
- ⇒ Large Pile-Up: to be able to produce some small number of very interesting events, need to produce so many of uninteresting ones that they even happen in the same crossing!
- ⇒ Large available energy implies the chance to produce a lot of soft or medium- $p_T$  stuff affecting the reconstruction.

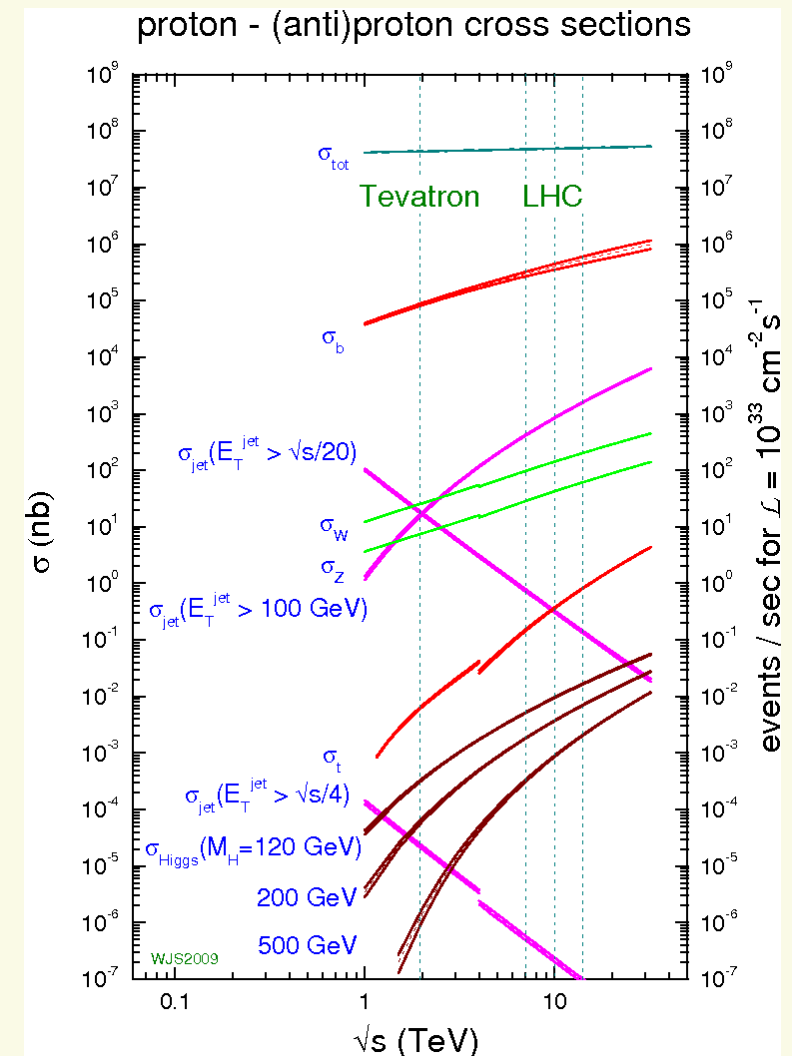



The LHC is **ACTUALLY** a QCD Machine aiming discovery: everything there...

- ... is affected by QCD-related effects

The LHC is a superb quark/gluon collider, so the final state is very prone to contain radiated quark and gluons.

- ... relies on the knowledge of QCD (e.g. PDF)

The initial state is not very clean: the hard process is clean, but surrounded by a lot of colour-related activities.

- ... is in the hands of quarks and gluons.

Unfortunately quarks and gluons are hard to work with, so dealing with a initial state with them is far from trivial: need of PDFs, models of parton showering,...

Even the final state is hard because quarks and gluons hadronize and cannot be observed directly.

Depending on the regime we are, sometimes we will be **dealing with hadrons (soft physics and similar) or with jets of hadrons (high- $p_T$ ).**

**However one thing are our intended measurements and another is what is there beyond our control, that also needs to be understood.**

**In a hadron collider, understanding QCD is not a priority, it is the only thing**

- The first relevant measurements performed at a (hadron) collider:
  - ⇒ Total cross section, specifically the inelastic part
  - ⇒ Differential cross sections for (charged) particle production
- All experiments made the measurements at every possible energies.
- Unavoidable piece for calibration (that requires little luminosity), understanding of performances but **also for tuning the soft-QCD parameters of the MC.**

## First LHC Result: EPJC 65 (2010) 111

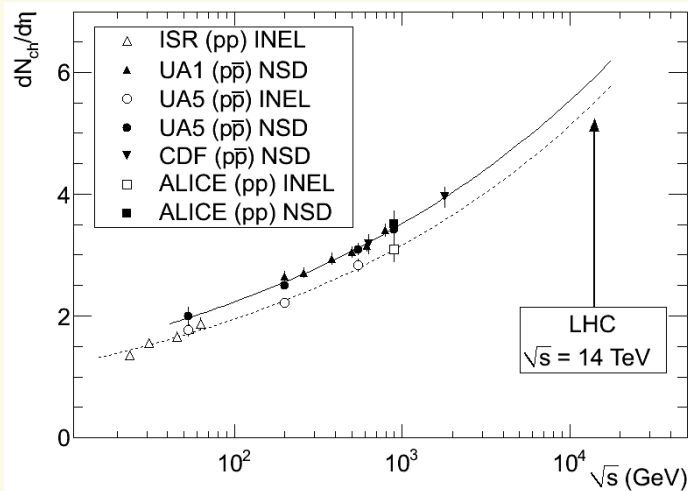

## PRD 83 (2011) 112001

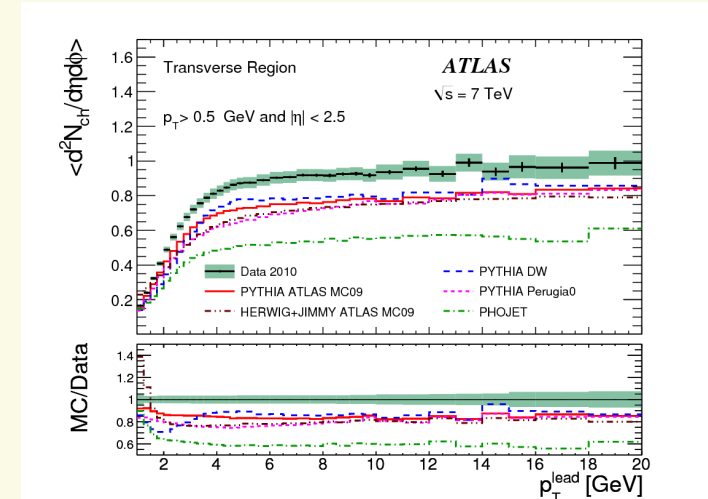
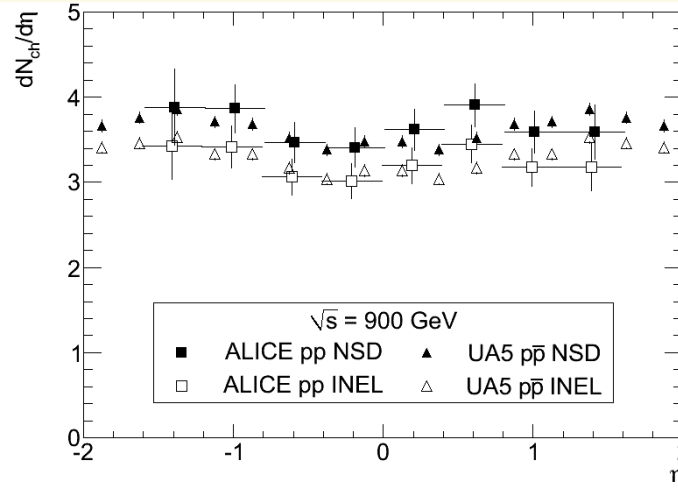

- The experiments work to use **the new tuning, as fundamental tools for the goals:**
  - ⇒ Simulation of the PU with proper multiplicities.
  - ⇒ Accurate description of the underlying event and related quantities (MPI, soft parton effects, ISR,...)

- Already with the measurements of particle production, the LHC results showed we entered in a new regime.

- Interesting effect looking at correlations between charged particles.

- CMS observed long-range near-side angular correlations:

(i.e. large  $\Delta\eta$  and small  $\Delta\phi$ )

- Appearing in high-multiplicity events (more than 100 charged particles).

- Similar effects previously observed in Heavy-Ion collisions.

⇒ Source of it still under discussion.

⇒ Even not clear it is the same as in Heavy-Ion collisions.

⇒ Also found in PbPb LHC collisions (and pPb collisions this year).

JHEP 09 (2010) 091

(a) CMS MinBias,  $p_T > 0.1 \text{ GeV}/c$

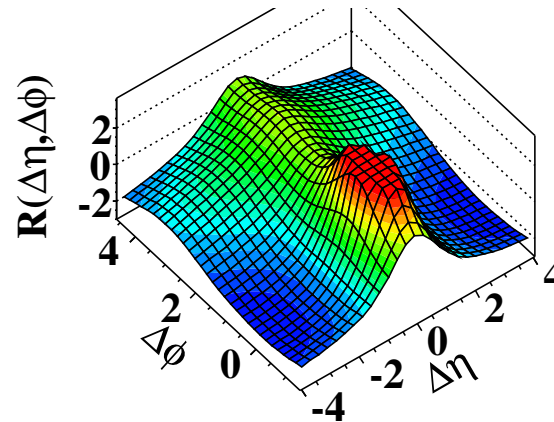

(b) CMS MinBias,  $1.0 \text{ GeV}/c < p_T < 3.0 \text{ GeV}/c$

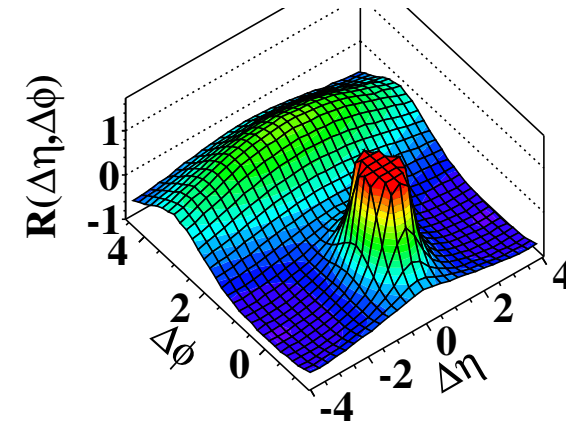

(c) CMS  $N \geq 110$ ,  $p_T > 0.1 \text{ GeV}/c$

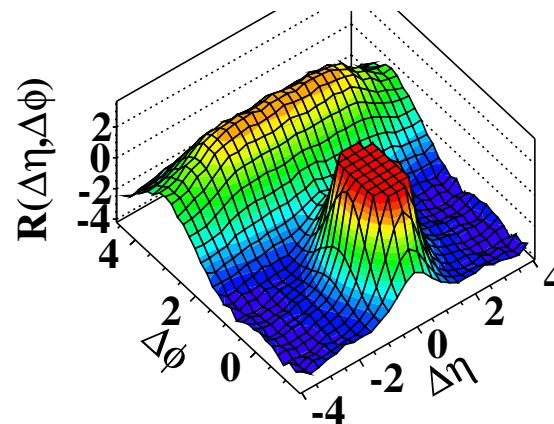

(d) CMS  $N \geq 110$ ,  $1.0 \text{ GeV}/c < p_T < 3.0 \text{ GeV}/c$

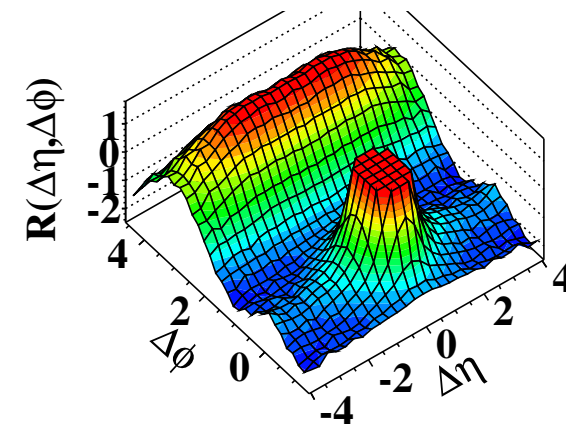

- Although soft QCD processes are very important because they appear everywhere in proton-proton collisions, they cannot be related to actual theoretical predictions based on (p)QCD.
- For that we have to use hard (high  $p_T$ ) processes, and identify jets and partons: the basic comparison with QCD measurements is the production of jets

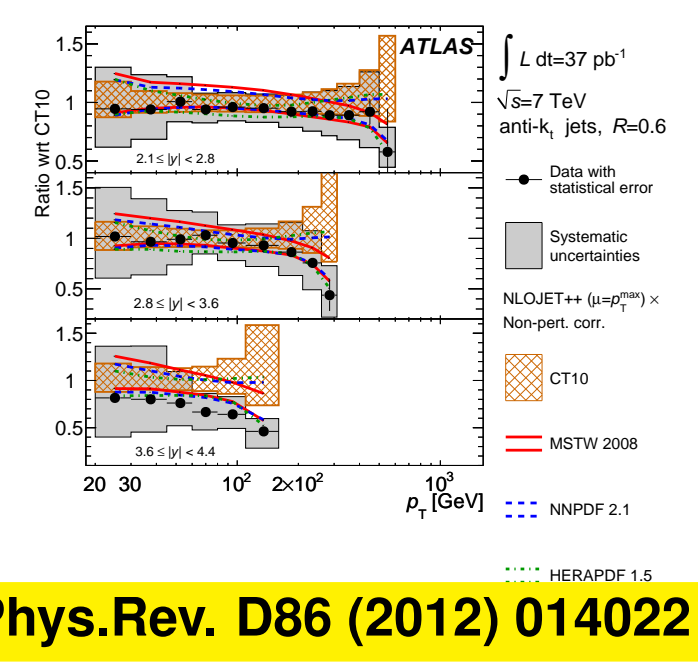
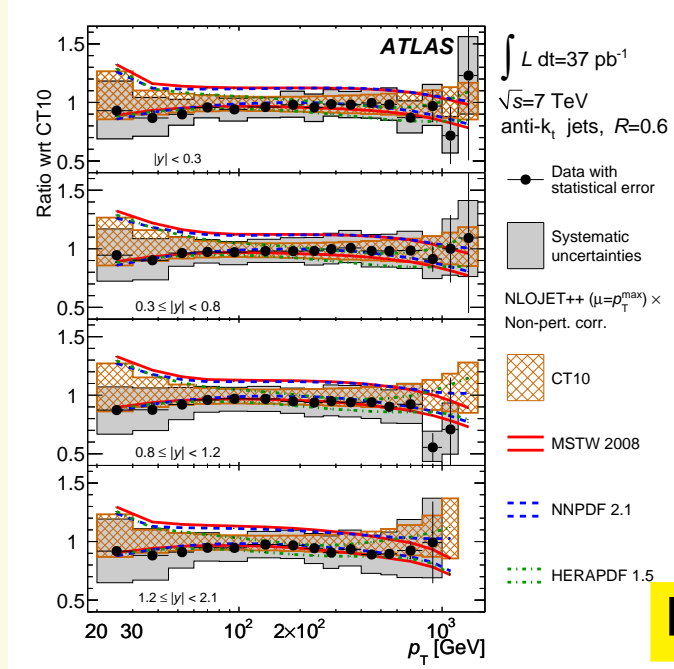
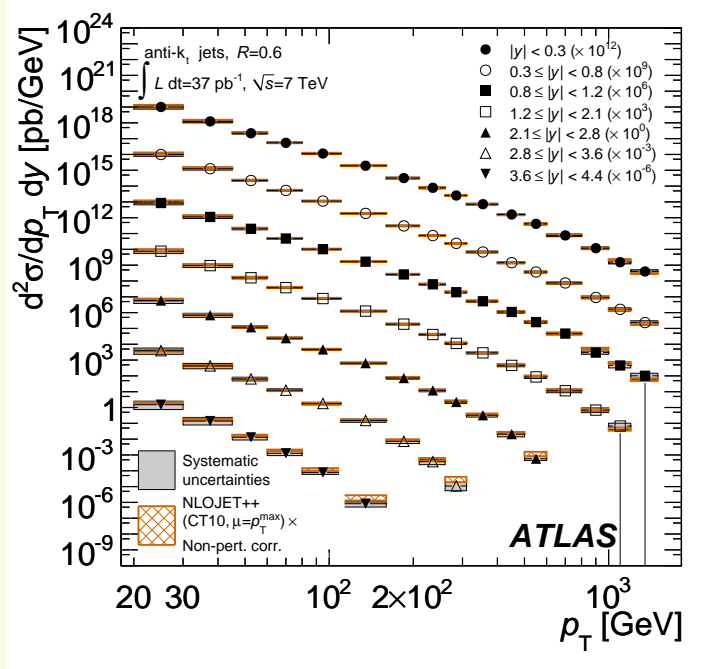

**Phys.Rev. D86 (2012) 014022**

- Comparisons to NLO tend to show good agreement after soft corrections.
- But some kinematic regions are a bit off.
- Usually related to problematic areas: larger spread in NLO QCD predictions, regions with larger soft-QCD or PDF-related uncertainties.



- Also the production of multijets allows to perform precise QCD-related measurements.
- CMS has studied the three-to-two jet ratio, in which many uncertainties get cancelled.

⇒ As a function of  $\langle p_{T1,2} \rangle = \frac{p_{T1} + p_{T2}}{2}$

⇒ Jets (Anti- $K_T$  with  $R=0.7$ )  
with  $p_T > 150$  GeV and  $|y| < 2.5$

⇒  $y = \cosh^{-1} \left[ \frac{E}{\sqrt{M^2 + p_T^2}} \right]$  is the rapidity

- But still very sensitive to the structure of QCD: very accurate predictions reproducing the data.

- Measurements in  $\langle p_{T1,2} \rangle > 0.4$  TeV were used to extract the value of  $\alpha_S(Q)$  confirming the running expectation (Renormalization Group Equation) beyond  $\mu = 400$  GeV.

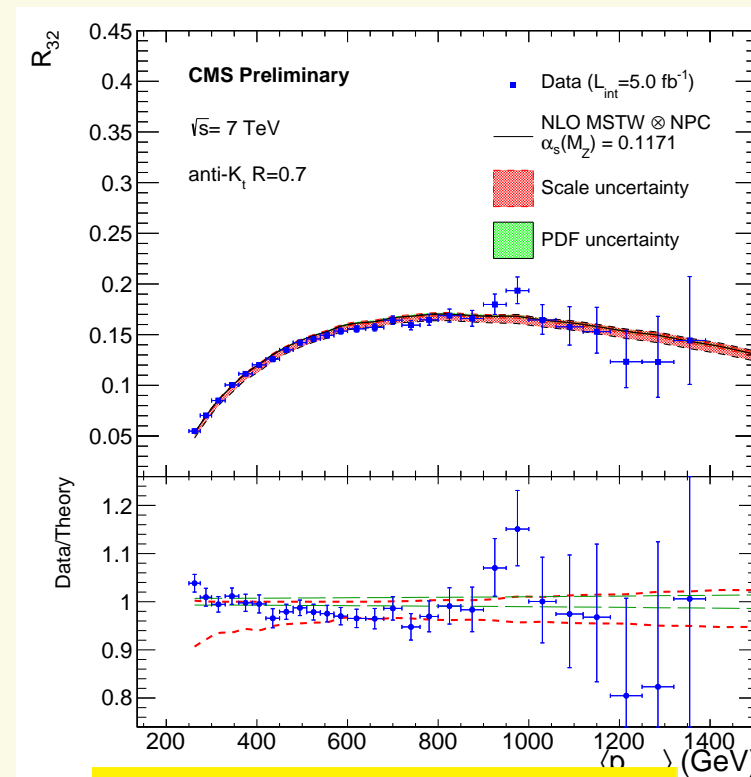

**CMS-PAS-QCD-11-003**

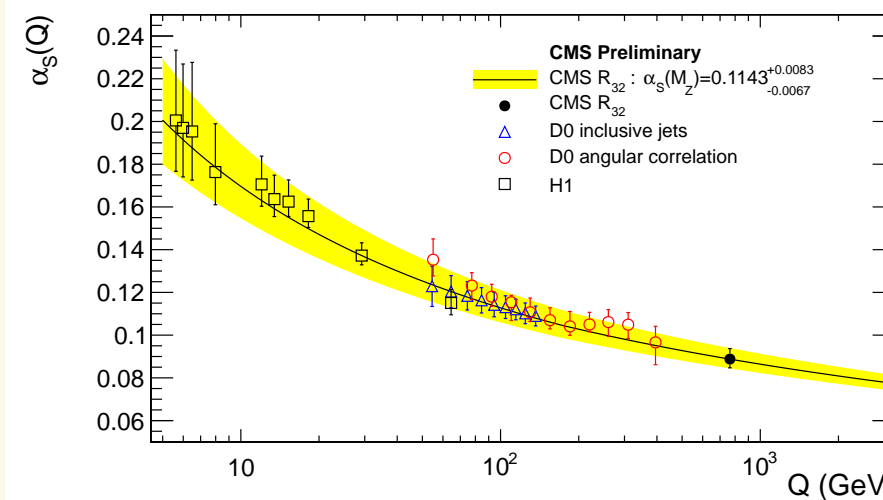

- The measurements of the jet production allows to constrain on the partonic content of the proton: **Parton distributions functions (PDFs).**

- i.e. understanding the structure of the proton.

- Measurements at LHC are **already sensitive to differences between different PDFs.**

- Even started to obtain PDFs using the LHC data: **ATLAS data modifies the High-x gluon and sea quarks!** (loosely constrained by HERA data).

- **PDF-related studies will appear in several topics during the lectures:**

**Obvious importance: we need to understand what we are colliding before we are sure enough to make claims about comparison with models:**

- Models are based on parton “colliding”.
- LHC collides protons... bunches of partons.

arXiv:1212.6660

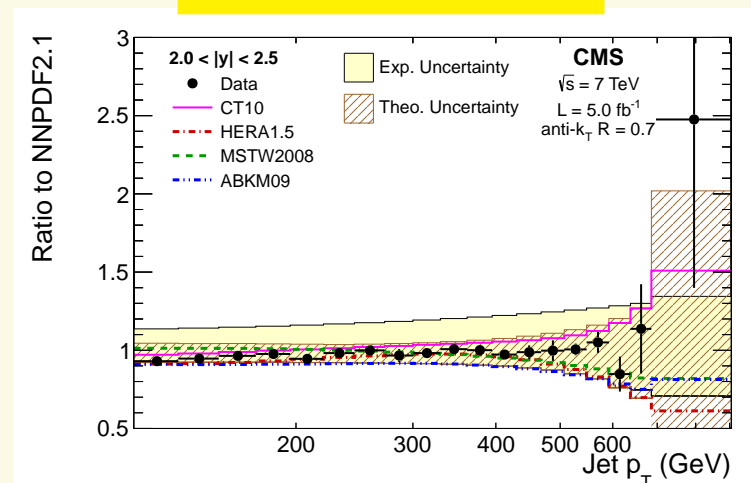

ATLAS-CONF-2012-128

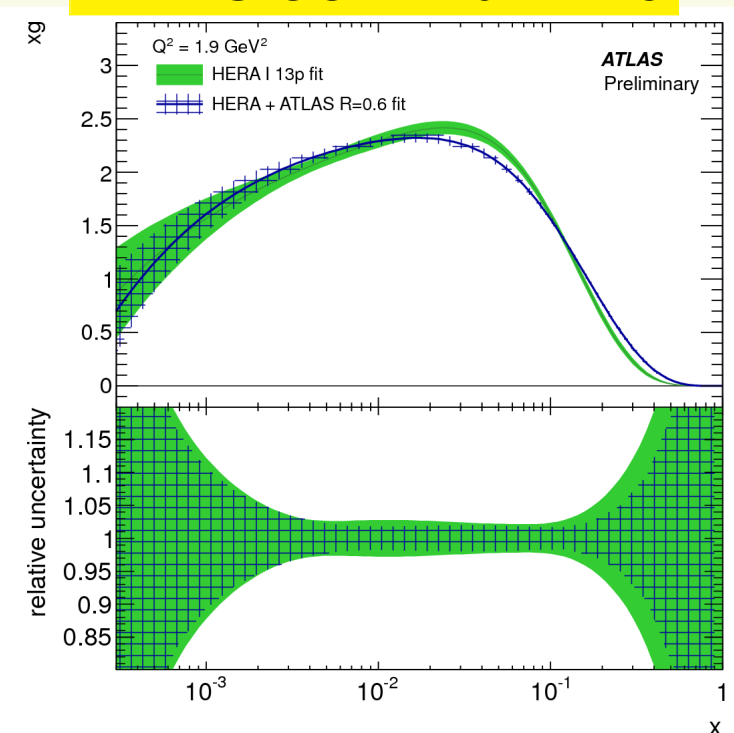

- The full explicit reconstruction of **low- $p_T$  hadrons** for spectroscopy and other flavour physics is done out of tracks (and sometimes leptons).
- For several reasons, this is not much useful when those hadrons have high- $p_T$  and are part of jets (i.e. high- $p_T$  partons).
- However, displaced tracks and vertices **provide a clean selection of jets containing a long-lived heavy-flavoured hadron** and tag the jet as a heavy-flavour jet:
  - ⇒ Basic approach: displaced tracks/vertex.
  - ⇒ Much more efficient than trying to look for leptons from semileptonic decays.
- These techniques have been improved during the last decade and **are very sophisticated today.**

Use of MVA, combine taggers, template of discriminants...

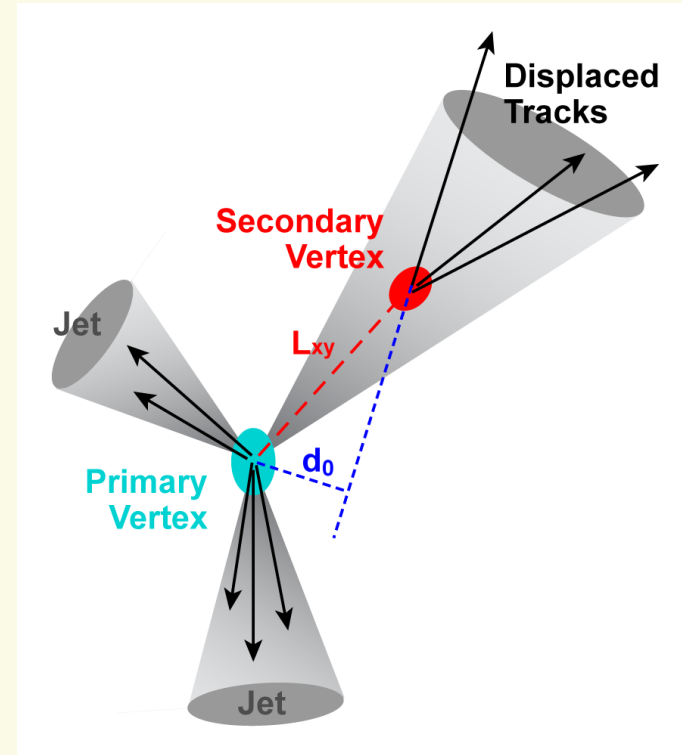

ATLAS-CONF-2012-156

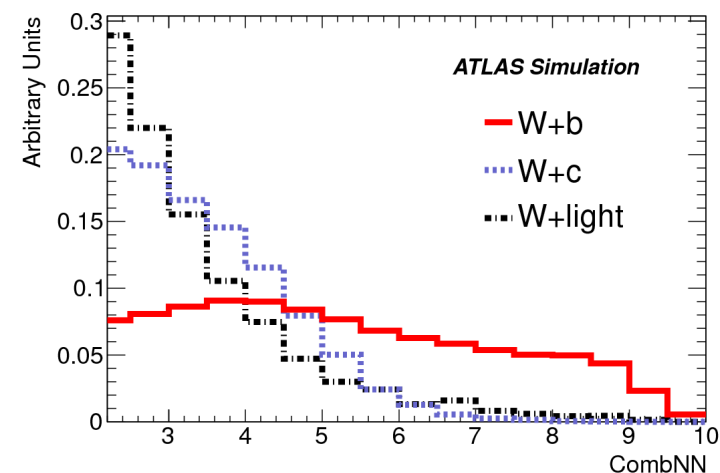



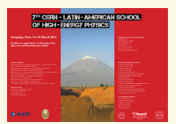

- The possibility of identifying jets originating from high- $p_T$  heavy-flavour quarks, allows to perform specific measurements for their production.
- Intended for broad interest:
  - ⇒ Comparison with theoretical predictions: QCD
  - ⇒ Provide feedback on production process: PDFs
  - ⇒ Useful to validate the tools (e.g. models used in MC) of a fundamental technique due to the importance of heavy flavour in searches (like the Higgs).
- Measurement by CMS done by requiring a secondary displaced-vertex.
- Cross-checked with a similar analysis that requires an additional muon.
- ATLAS has similar analyses.
- Predictions do a good job (at least overall)

arXiv:1210.0441

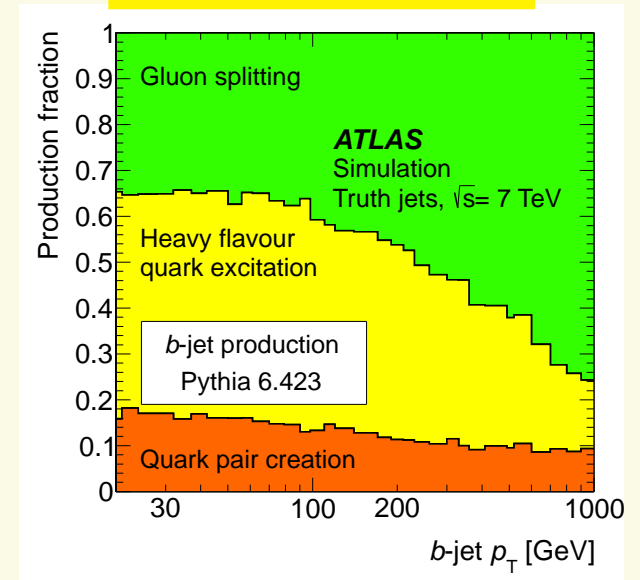

arXiv:1202.4617

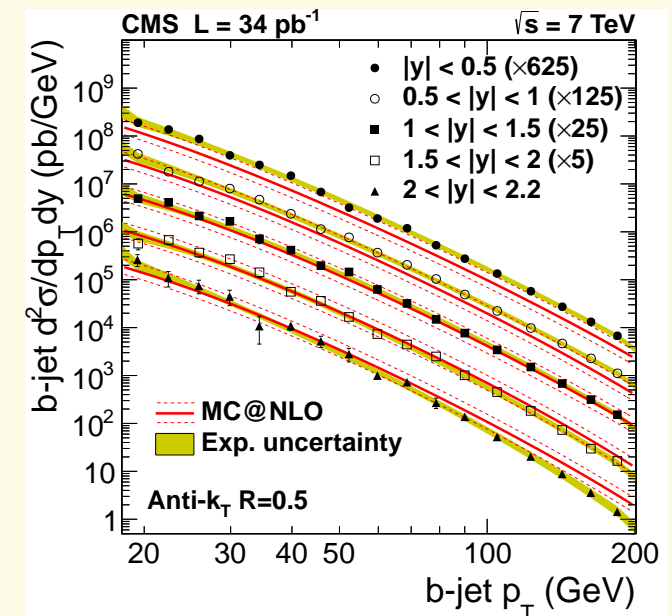

- One of the “hot topics” is how to identify the presence of two Heavy-flavour hadrons within the same jet:

⇒ Merging of two b jets in boosted topologies (below)

⇒ Rejecting gluon-splitting production of Heavy-flavour.

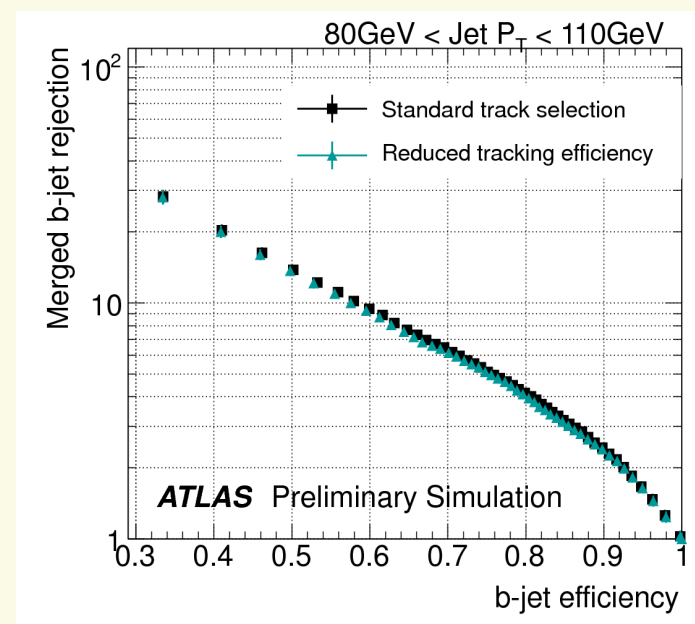
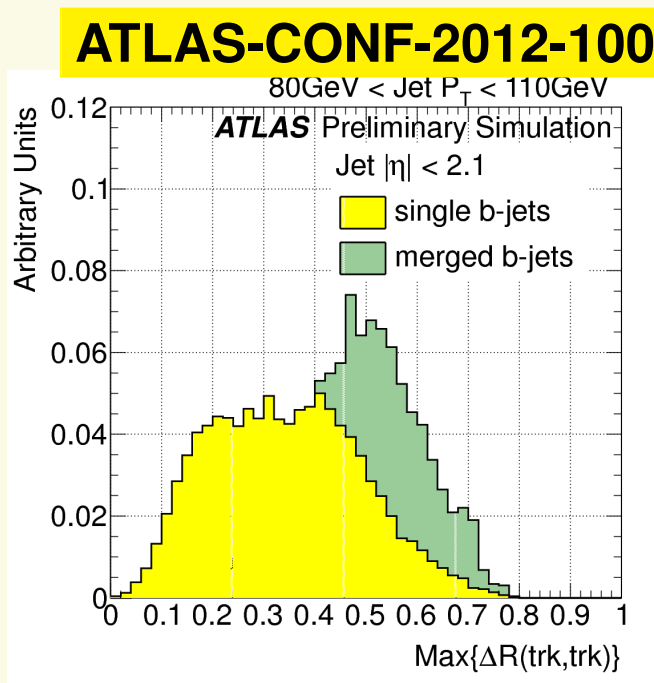
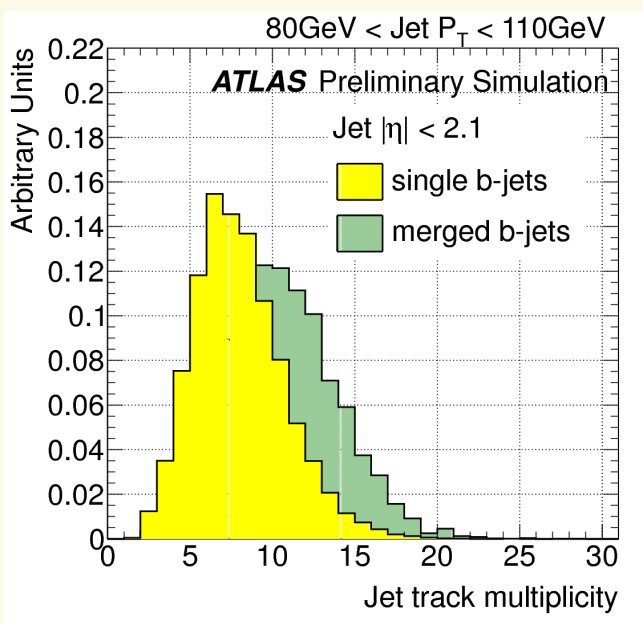
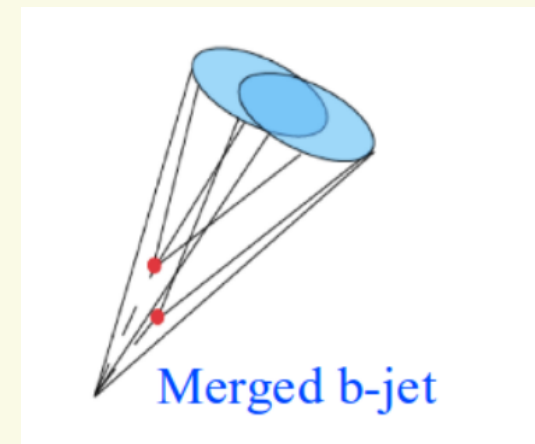

- Exploiting the differences in tracking-related variables
- This likelihood allows a good rejection for an efficient selection of single-B jets.



- As discussed before, a characteristic of the LHC is its goal to study objects whose mass is much smaller than the available energy.

(Until something heavy is found, of course)

- This brings the need to have well control of boosted objects in the transverse direction:  $m/p_T \ll 1$ , and to deal with the decaying object

- In the case of lepton pairs, the effect is relevant for isolation calculations.

- In the case of jets the problem is that they get merged and reconstructed as a single jet:

⇒ Need to deal with the internal substructure to recover the information on the original partons.

⇒ Many many techniques to handle this issue: specific studies to understand these jets.

⇒ Used to identify boosted  $W$  and top quarks already for searches (e.g.  $Z' \rightarrow t\bar{t}$ ).

No time to cover in detail, but worth it to mention since this will become more important in the future (higher energy).

arXiv:1206.5369

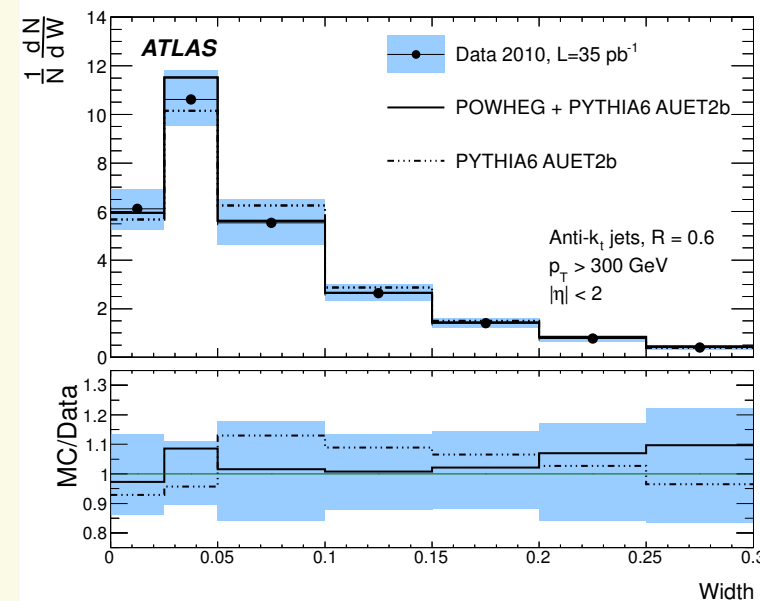

JHEP 09 (2012) 029

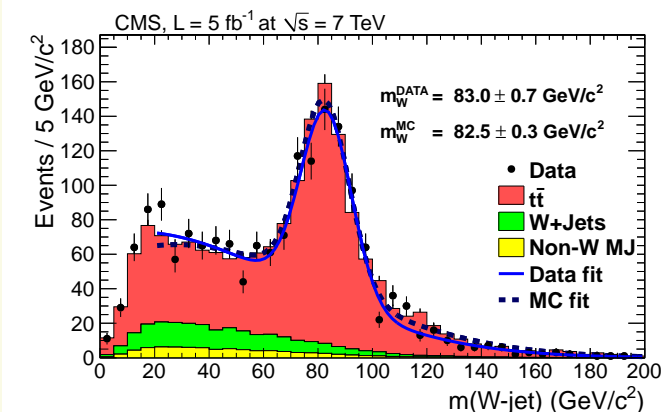



- Since at high energies protons are “bunches of partons”, it is **not uncommon** that several parton pairs collide at the same time.
- **This is a complicated topic:** it might be even behind the origin of the ridge observed by CMS.
- Several efforts to try to **learn as much as possible** about it and to improve the modeling of the Underlying event.
- Recent analysis by ATLAS to measure the contribution from double-parton interactions using  $W$ +dijet events.

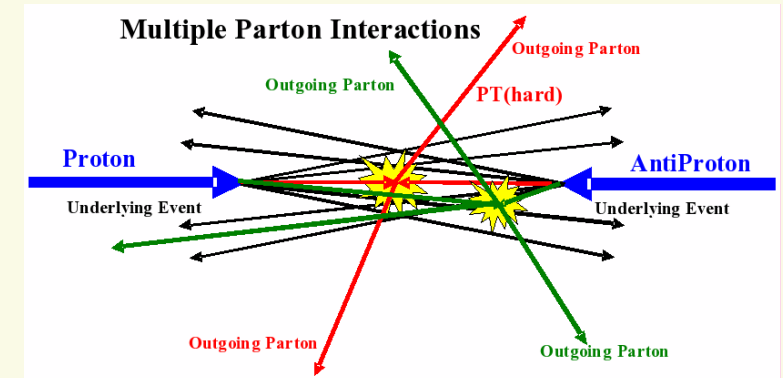

- Extracting contribution using template method.
- The fraction of double-parton-interaction in the sample is

$$f_{DPI} = 0.16 \pm 0.01(\text{stat}) \pm 0.03(\text{syst})$$

- **In good agreement** with expectations (tuned to previous data).

Other interesting measurement is double- $J/\psi$  production at the LHCb experiment.

## ATLAS-CONF-2011-160

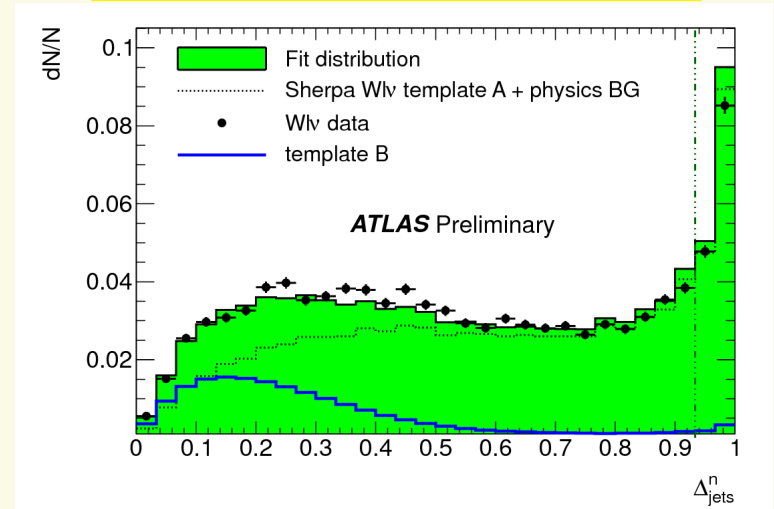

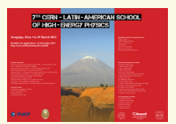

- Measurements related to **soft processes**, like total proton-proton cross sections, forward particle production, and similar are very important at the LHC.
- It also includes studies of diffractive processes, even if they could be “hard” (as in dijet production)
- The investigation of **colourless exchange** via specific detectors and with rapidity gaps has kept its importance in the LHC era.
- Also motivated to improve theoretical/MC description of underlying event and other soft processes, but very important since they take part in collisions where high- $p_T$  physics
- Nowadays **rapidity gaps between jets have become a common tool for searches to distinguish signal** (may produce jets from colourless objects) and background (producing QCD-radiation jets).

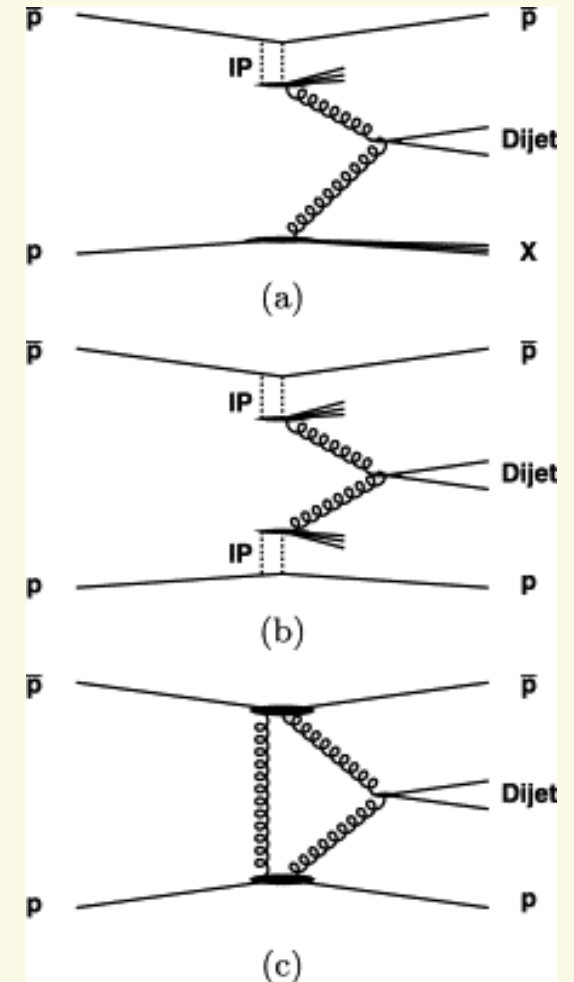

And a lot of this relies on MC predictions!!!

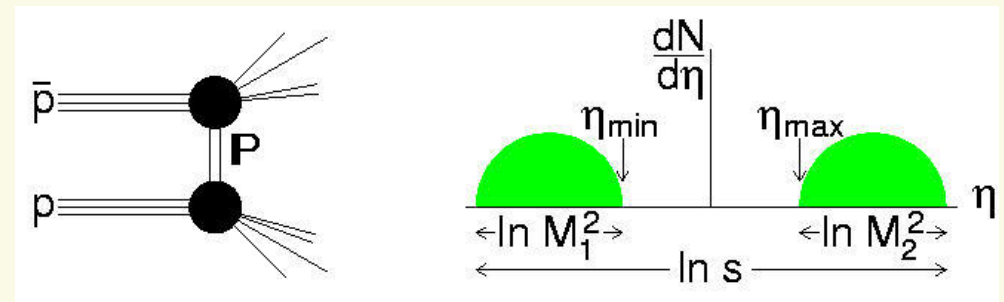

- LHCb is very well adapted for forward physics due to the very forward coverage.
- Additionally it has very good particle ID so it can perform measurements that are not available to ATLAS and CMS.

EPJC 72 (2012) 2168

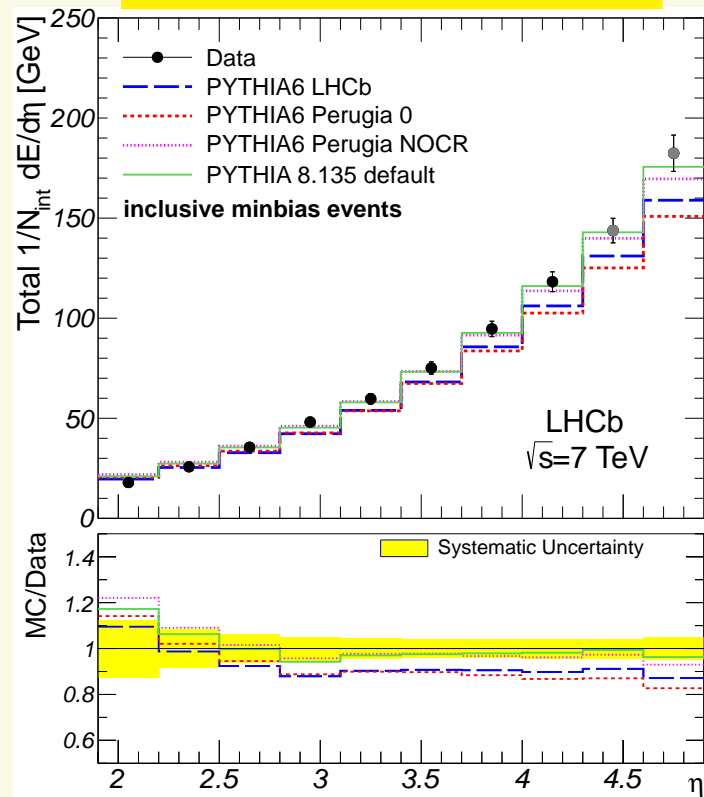

arXiv:1212.4755

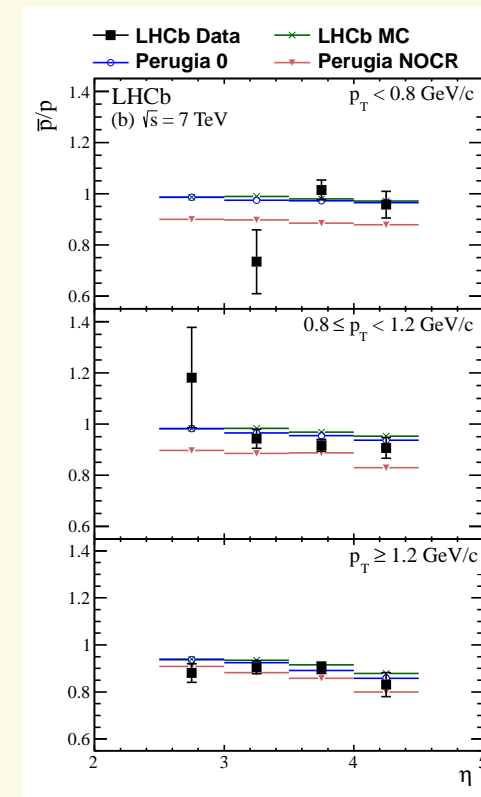

⇒ Interesting measurements of prompt hadron production ratios and energy flow in the very forward region.

⇒ Compared to Pythia and to cosmic-ray event generator.



- Another example of exclusive production is the colourless exchange mediated by photons.
- This makes the LHC to become a photon collider!

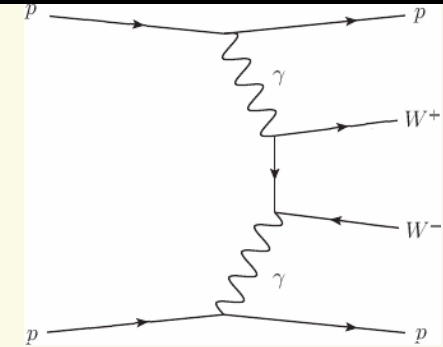

Background is limited by studying the  $e\mu$  channel only ( $\mu\mu$  used as control sample) and the selection of exclusive-production events is done by vetoing the presence of additional tracks in the  $e\mu$  vertex.

- 2 events are observed (from 2.2 expected on 0.84 of background), which allowed to measure:

$$\sigma(pp \rightarrow W^+W^-p^{(*)}p^{(*)} \rightarrow \mu^\pm e^\mp p^{(*)}p^{(*)}) = 2.1_{-1.9}^{+3.1} \text{ fb}$$

- The significance of this value is  $1.1\sigma$ . **More data is needed!**
- Result was also used to set limits on the exclusive production of  $WW$  looking for anomalous quartic couplings by using sample with  $p_T > 100 \text{ GeV}$ .

## CMS-PAS-FSQ-12-010

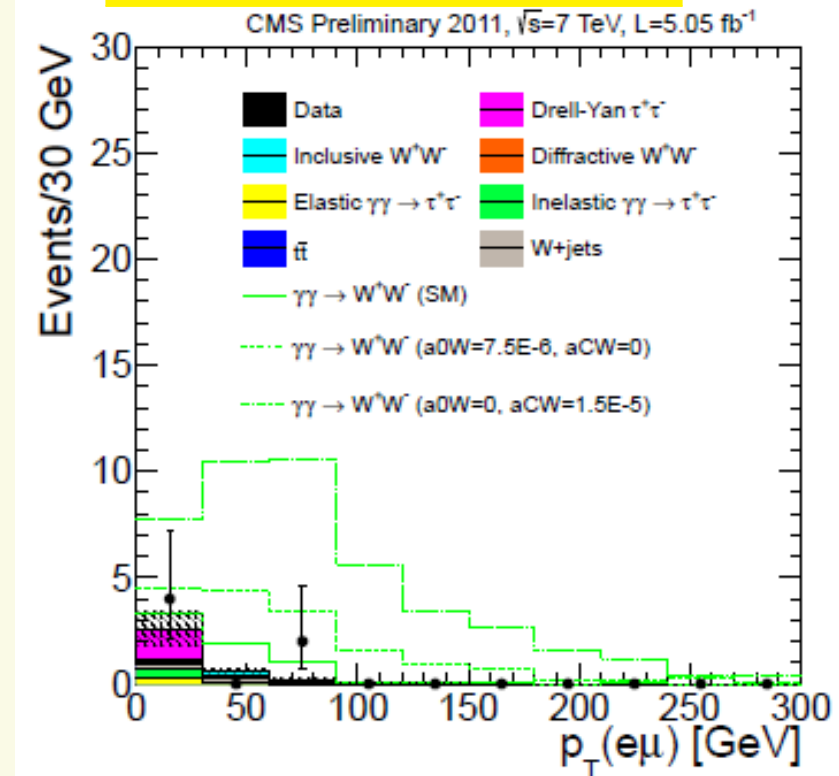

# Electroweak boson and diboson production at the LHC



- Usually considered as “QCD” because the photons were providing information on quarks.
- Photons are good probes of the hard process since they are not modified by soft effects.
- And they are able to distinguish between quarks!
- $\gamma$ +jet is one of the fundamental calibration tools.
- Diphoton production also provide very stringent test of the SM predictions.
- It is an important background for many interesting searches.

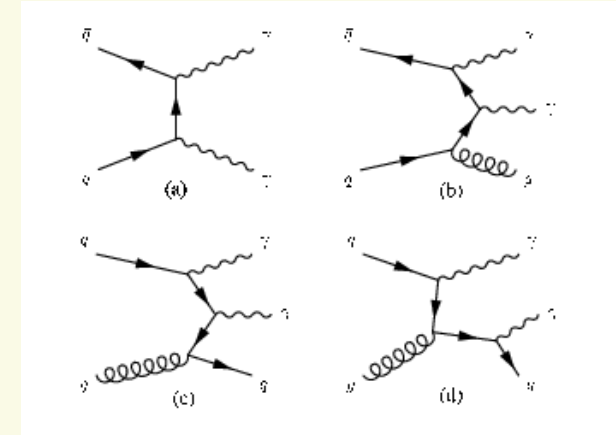

arXiv:1211.1913

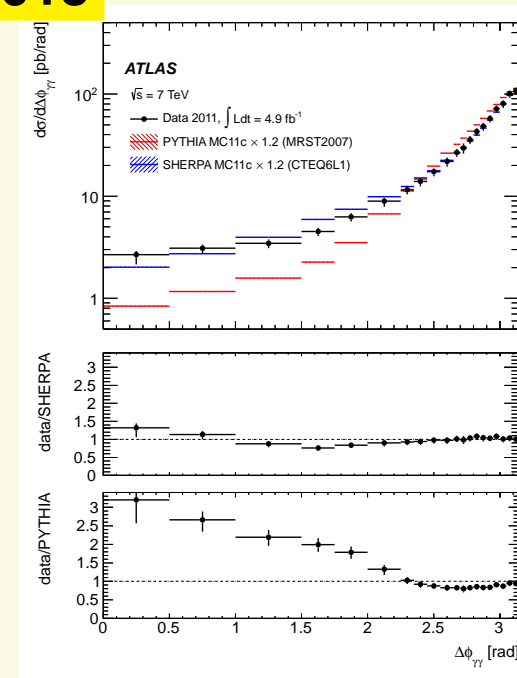
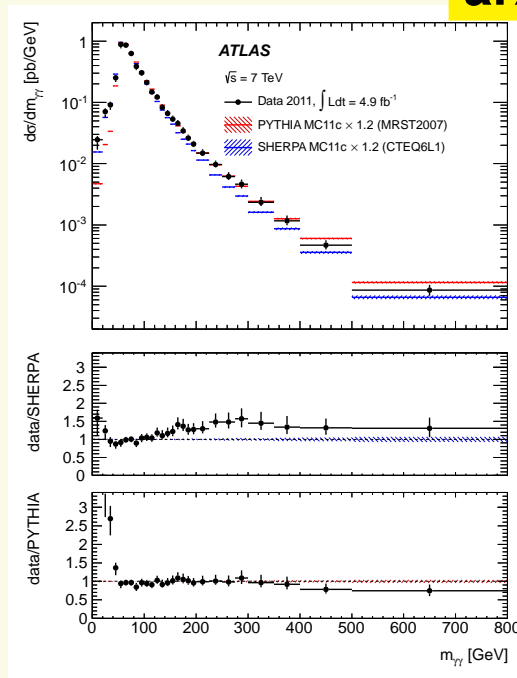



- Production of the electroweak bosons are a fundamental test of the SM predictions.
- $W$  production has been one key elements in hadron colliders (including its discovery).
- Production of  $Z$  is a fundamental piece to understand and calibrate the detectors.
- Events containing  $Z$  and  $W$  may appear associated to New Physics.
- At the LHC measurements of the production are hard due to the environmental conditions (tight trigger cuts, pile-up,...) but cross sections are so high that small datasets are enough.
- Measurements at 8 TeV already available: **CMS-PAS-SMP-12-011**

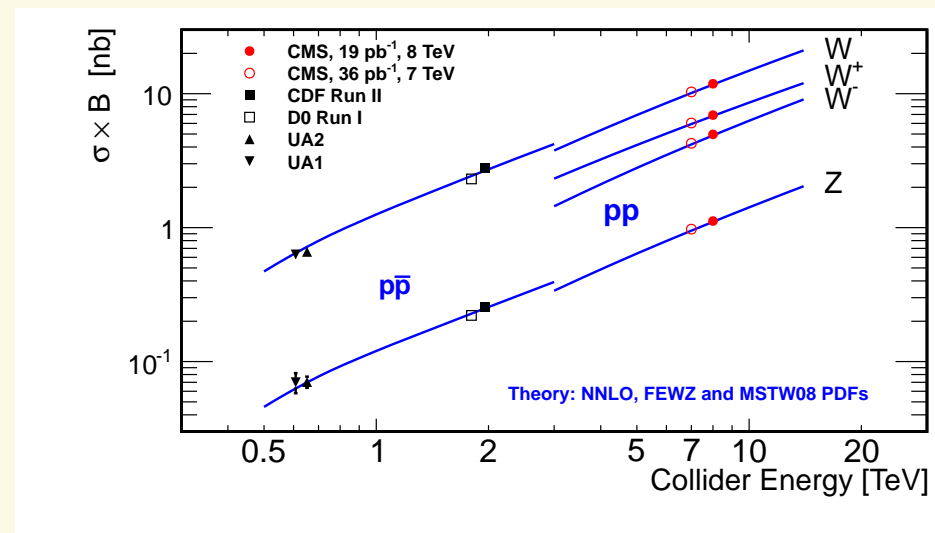
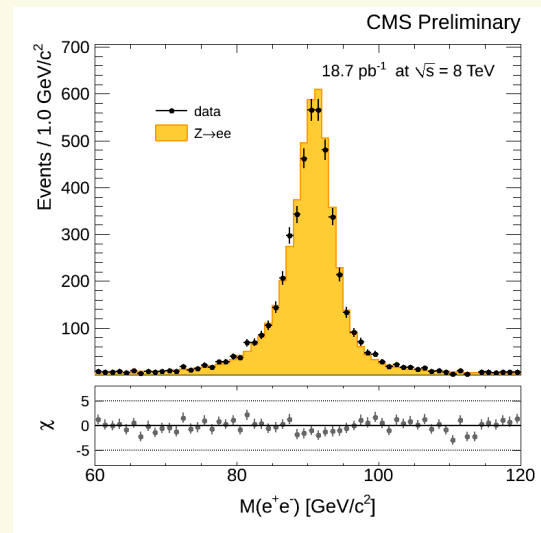
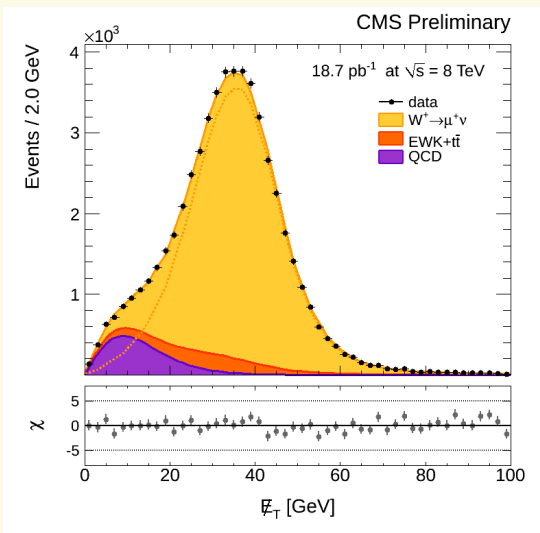
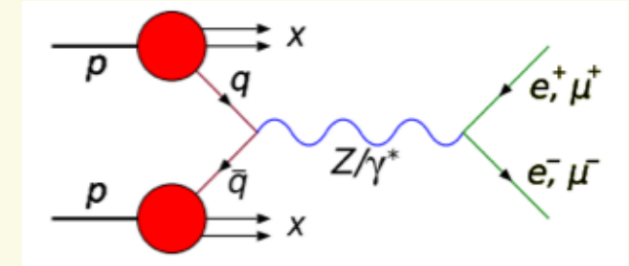

- The importance of the EWK bosons is so large that the study of their properties is also a key part of the LHC program.

Specially the measurements sensitive to the proton structure.

The LHC is the first proton-proton collider in which EWK boson production (very sensitive to the sea quarks) is available for studies.

- Measurements of the ratio  $W^+$  to  $W^-$ :

- ⇒ Specially differential ( $\eta$ )
- ⇒ Measurements useful for PDF studies
- ⇒ Published as **PRD 85 (2012) 072004**

- Other very interesting:  $Z \rightarrow 4l$

- ⇒ Never observed at hadron colliders
- ⇒ A fundamental calibration piece for  $H \rightarrow 4l$
- ⇒ Published as **JHEP 12 (2012) 034**

Due to time constraints, not possible to cover all the relevant results on  $W$  and  $Z$  properties coming from the LHC.

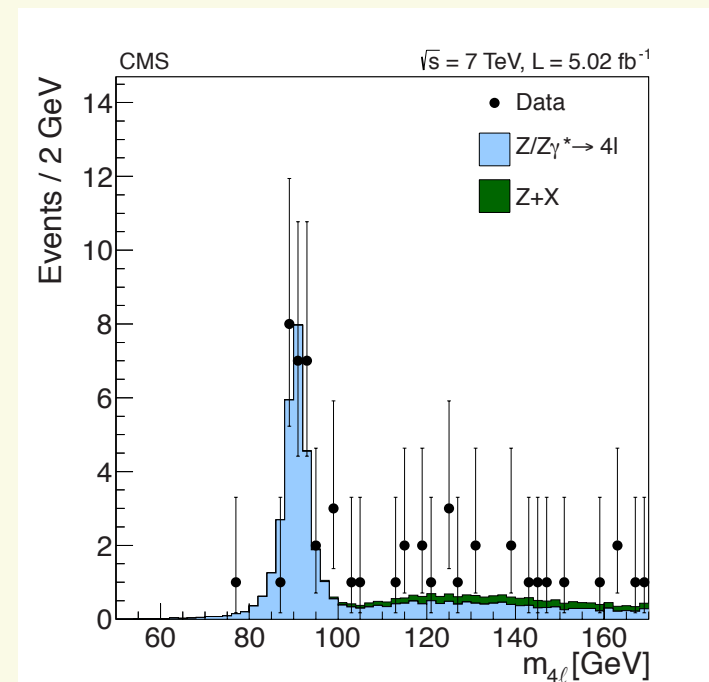
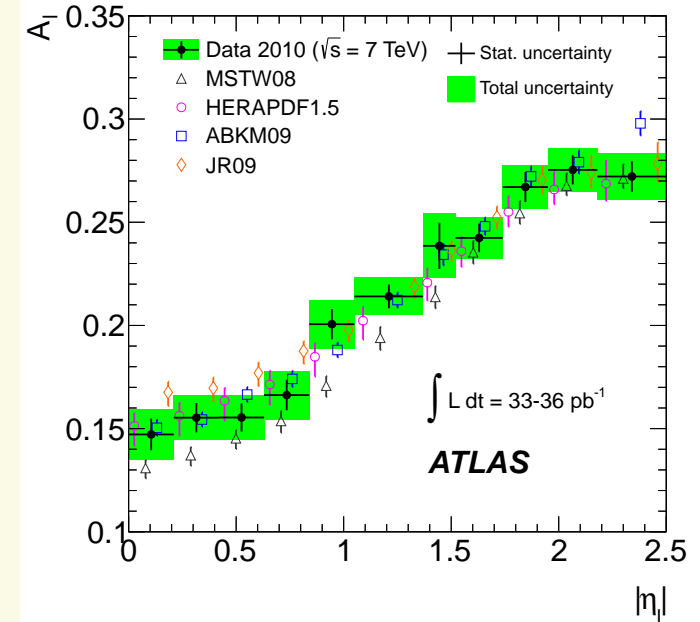



Although intended for Heavy Flavour physics, the LHCb made use of its great coverage in the very forward region to reconstruct  $Z$  and  $W$  bosons.

JHEP 06 (2012) 058

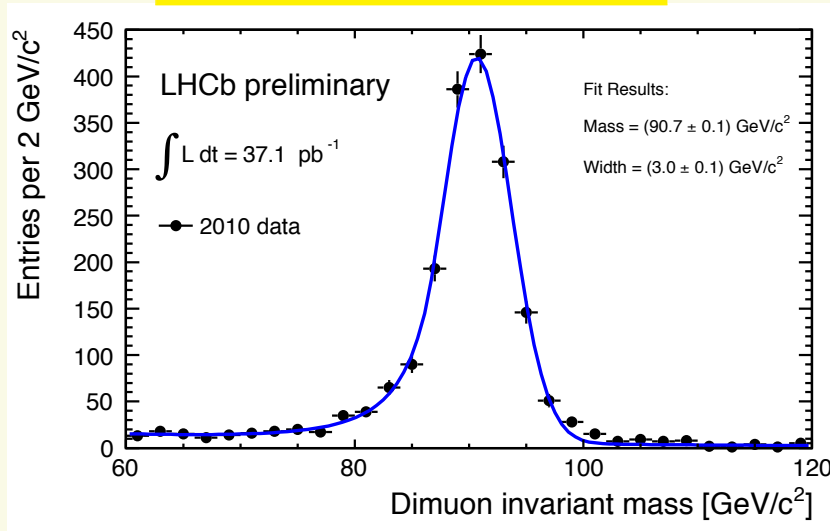

JHEP 01 (2013) 111

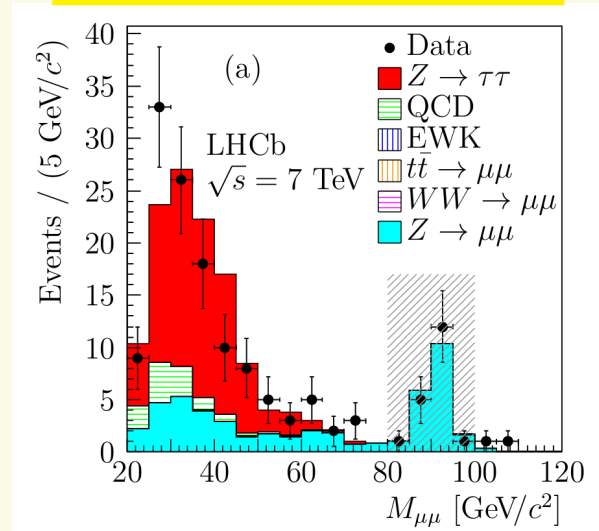

Sensitive to a kinematic region of the parton structure in the proton not accessible by others experiments (HERA, Tevatron nor ATLAS/CMS).

⇒ Impressive set of measurements of the forward  $Z$  production, even  $Z \rightarrow \tau\tau$ .

⇒ Measurements of  $W$  charge asymmetry in a very forward region.

⇒ Data will have a big impact in PDF fits.

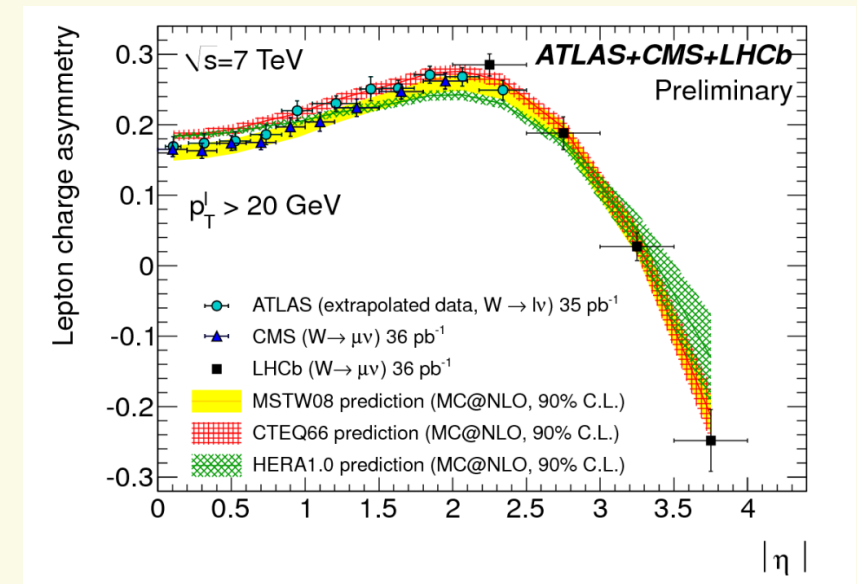

- Production of jets in collisions producing a vector boson allows the study of perturbative QCD in a well-controlled environment.

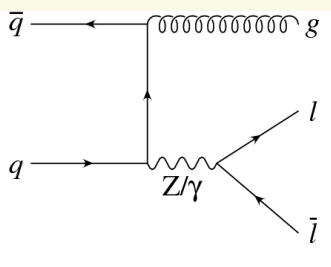

- Very stringent tests of pQCD.
- Since bosons may be understood as a “probe” of the underlying process, the events provide non-trivial information about the partons.
- Sensitive to the partonic content of the proton.

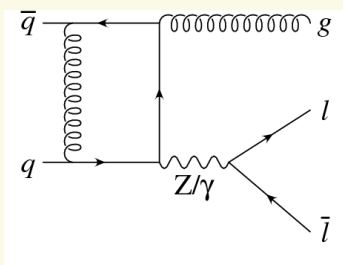
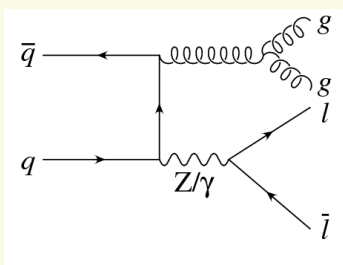
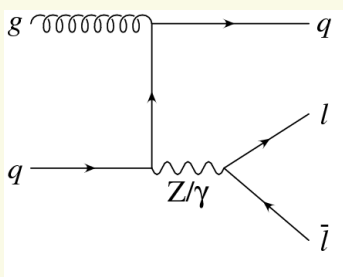

arXiv:1201.1276

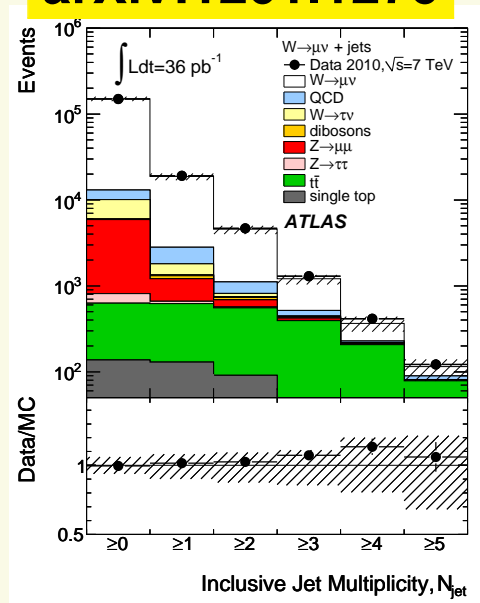

arXiv:1301.1646

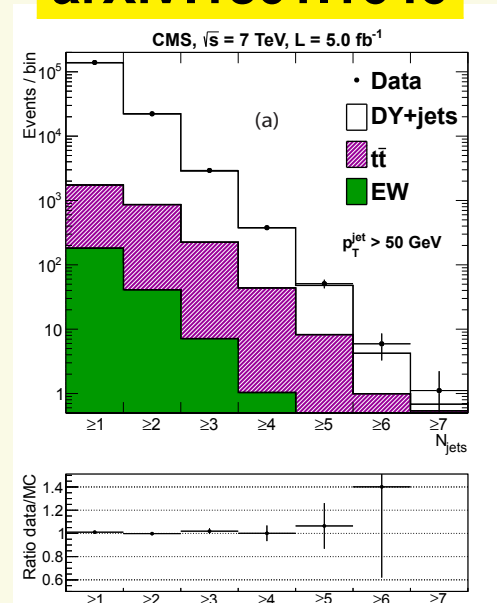

- They are also major backgrounds to basically any search.
- Very important to have the tools (MC, theory predictions) well understood since these are the basic samples for high- $p_T$  physics.



- As always, not only the inclusive cross sections are interesting, but also the differential ones and other quantities: ratios,...
- These provide very challenging tests for the predictions by the SM (MC models).
- They are also important by itself, even in searches: several signatures of New Physics ARE ACTUALLY  $V$ +jets (e.g.  $W + X(\rightarrow jj)$ )

PLB 708 (2012) 221

arXiv:1208.3477

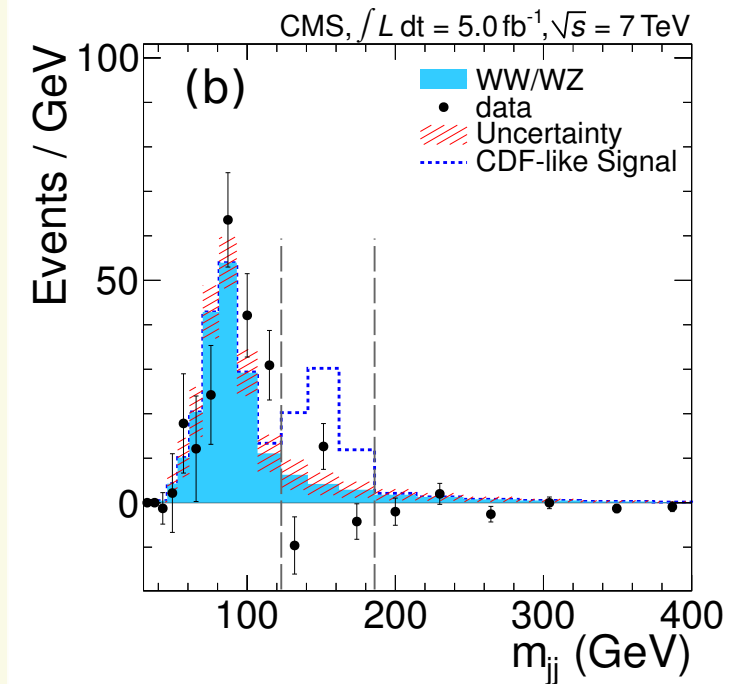
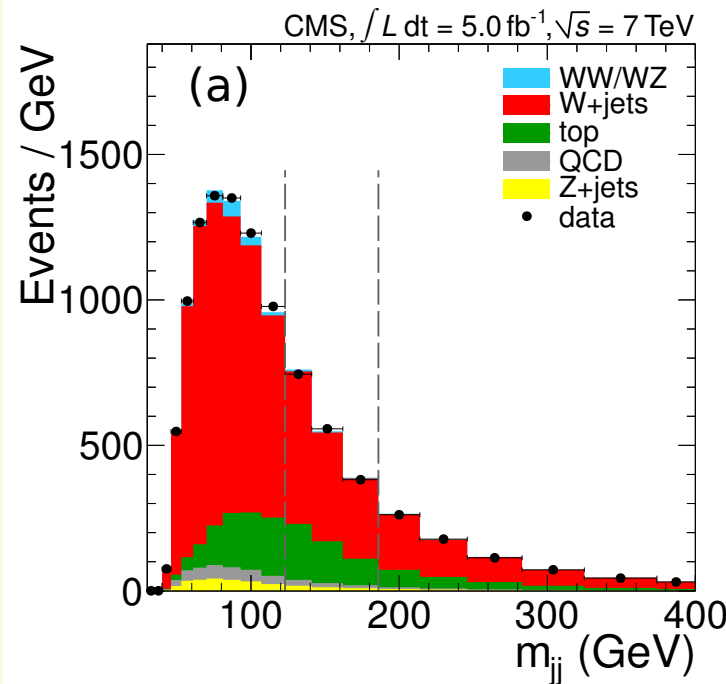
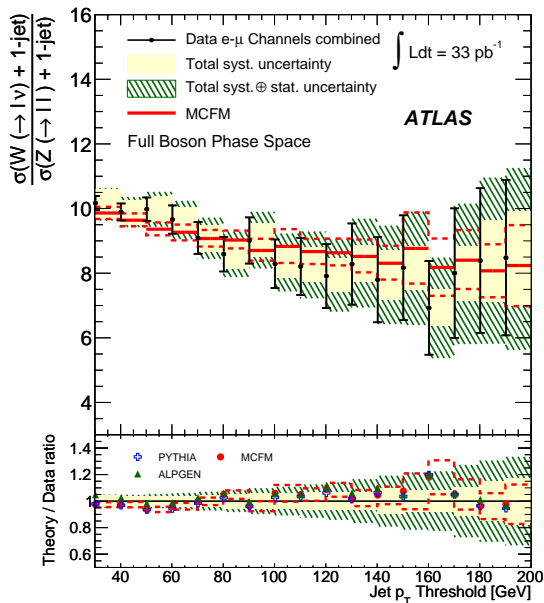

- Other many studies are performed in the  $V$ +jet(s) samples. Even related to Underlying Event (in Drell-Yan production) or for multiple-parton interaction.



- The production of Heavy-Flavour has always been hard to reproduce with MC calculations, even for inclusive jets.
- In the case of  $V$ +jets the problem is still present.
- Datasets are already large enough to perform precise comparisons.

## ATLAS-CONF-2012-156

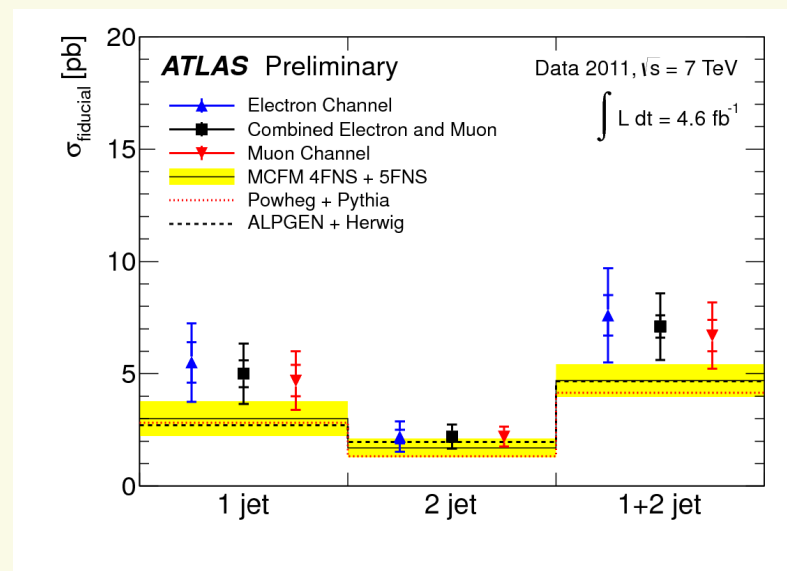
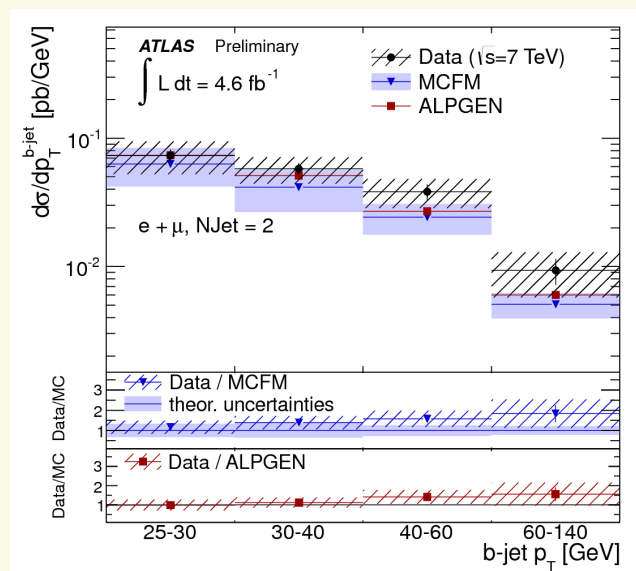
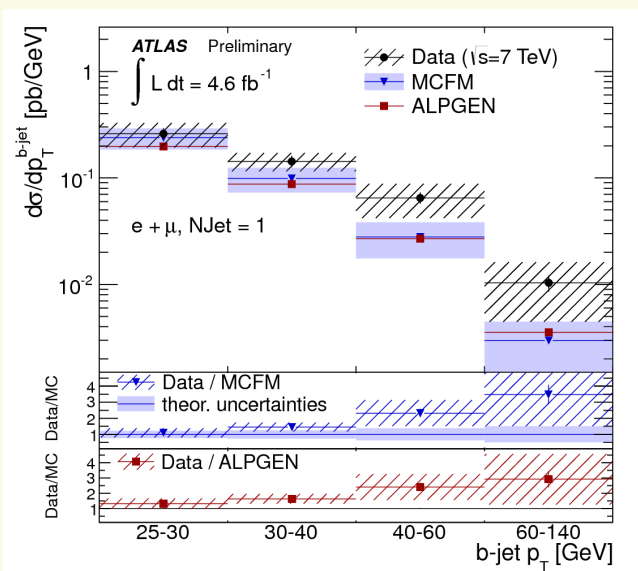

- Agreement could be improved.
- These events are a very common background for searches: **understanding this is a priority in the (theory?) program.**

- The flavour-changing nature of the  $W$  makes it special so it may produce flavour from the proton, in this case charm.

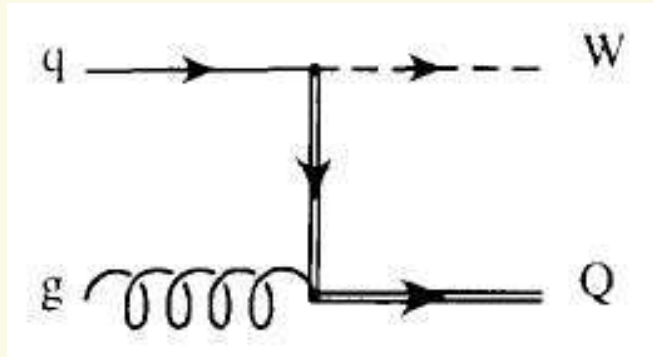

- The advantage of this is that the charm
  - ⇒ is identified as a heavy-flavour jet
  - ⇒ is created highly correlated with the initial state (given the  $W$  and the charm, that fixes the original parton)
- The main interest of the measurement is the sensitivity to the parton distribution of the strange quark
- and separate the strange quark from the antiquark.

$$R(W^+ + c/W^- + c) = 0.92 \pm 0.19(\text{stat}) \pm 0.04(\text{syst})$$

$$R(W + c/W + j) = 0.143 \pm 0.015(\text{stat}) \pm 0.024(\text{syst})$$

- In good agreement with expectations.

## CMS-PAS-EWK-11-013

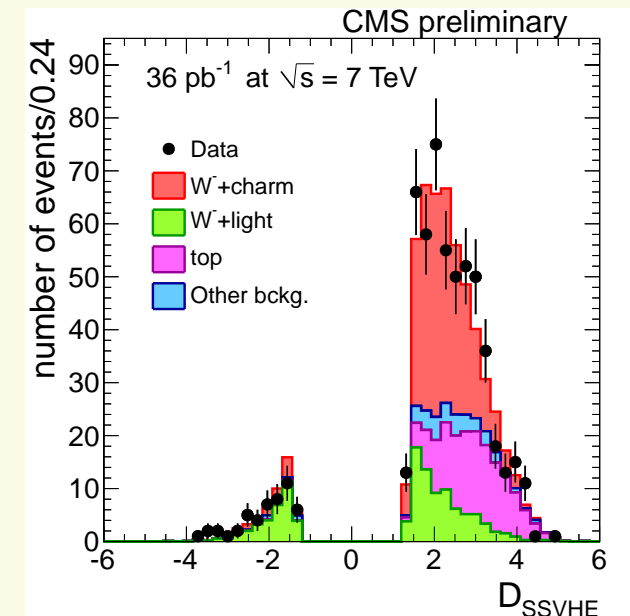
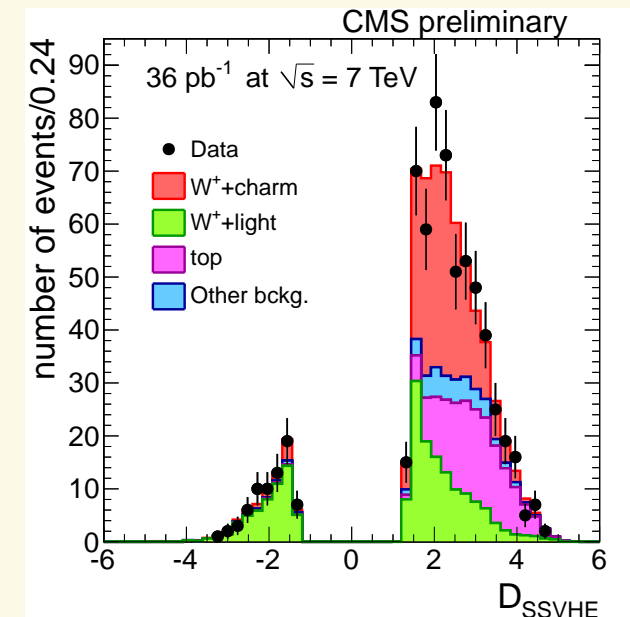



- Another interesting process, partly due to the low cross section at the Tevatron.
- At the LHC is possible to perform very precise comparisons with predictions and models.

JHEP 06 (2012) 126

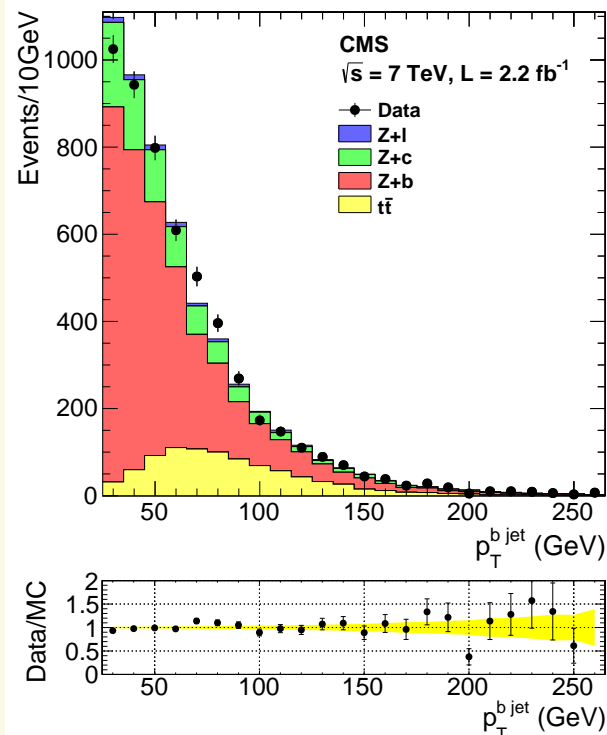

CMS-PAS-SMP-12-003

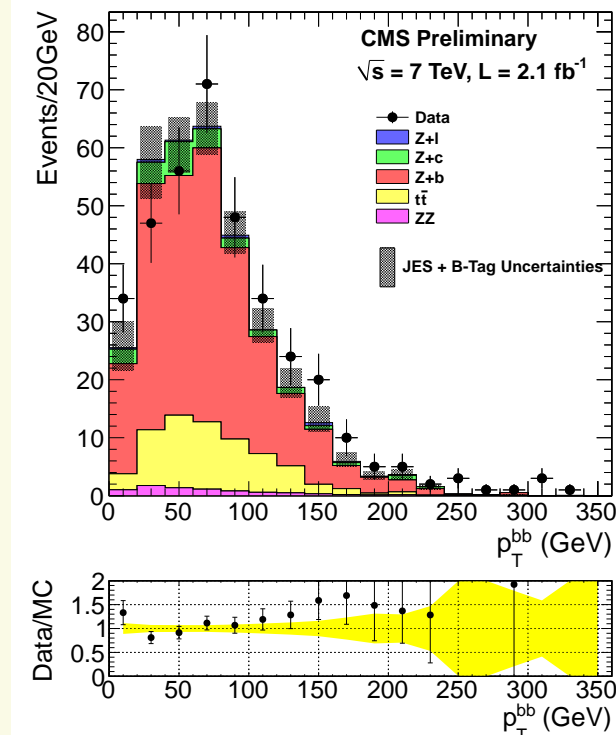

- ⇒ MC (Madgraph) is able to describe the distributions.
- ⇒ Most of it ok, likely missing higher orders.
- ⇒ However, when requiring explicitly two b-jets the agreement is not that good.
- ⇒ Note that even being the same processes/diagrams the relative weight is not the same: further work needed to understand this.



- The large cross section of boson production at the LHC opens new production mechanisms that were not accessible before.
- Interest about **Vector-Boson Fusion (VBF)** processes for Higgs requires to understand these processes in controlled environments.

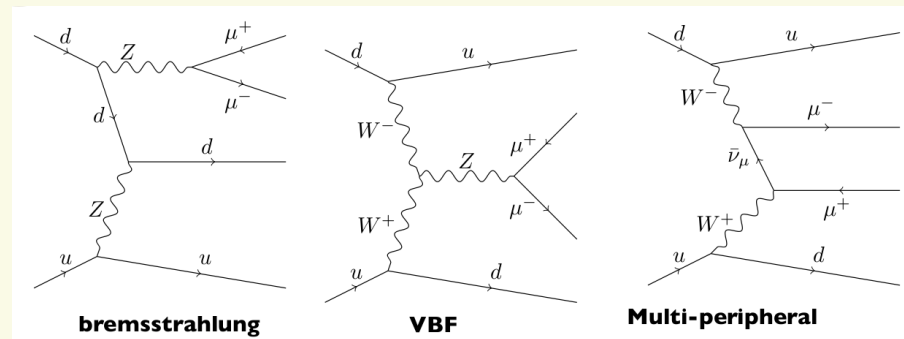

## CMS-PAS-FSQ-12-019

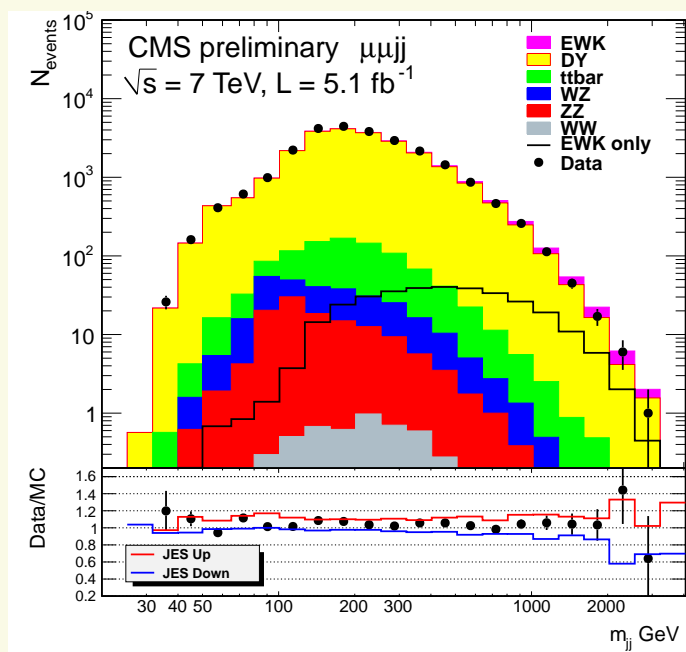

- “Tagging” VBF with two forward jets.
  - Analysis used **dijet mass and angular information** to reduce the background from  $Z$ +jets production.
  - Measured cross section
- $\sigma = 154 \pm 24(\text{stat}) \pm 46(\text{syst}) \pm 27(\text{th}) \pm 3(\text{lumi}) \text{ fb}$
- is in good agreement with NLO predictions.

It should be remarked that this analysis also helps to understand the (QCD-radiating) production of jets in the forward region, the one with larger uncertainty.

- Production of more than one EWK boson is one of the most sensitive test of the SM structure: **directly probing the non-Abelian vertices.**
- Cross sections are small due to the multiple weak couplings.
- But very sensitive to New Physics: New couplings involving bosons.
- At the LHC we have entered a **new era for diboson production: large samples.**
- They are **very important backgrounds to be understood since many searches rely on the expectations for these processes.**
- In addition, **dibosons have become even standard references for validating and calibrating experimental tools.**
- As always, this requires a parallel work to get the theoretical predictions (calculations, MC programs) well under control.

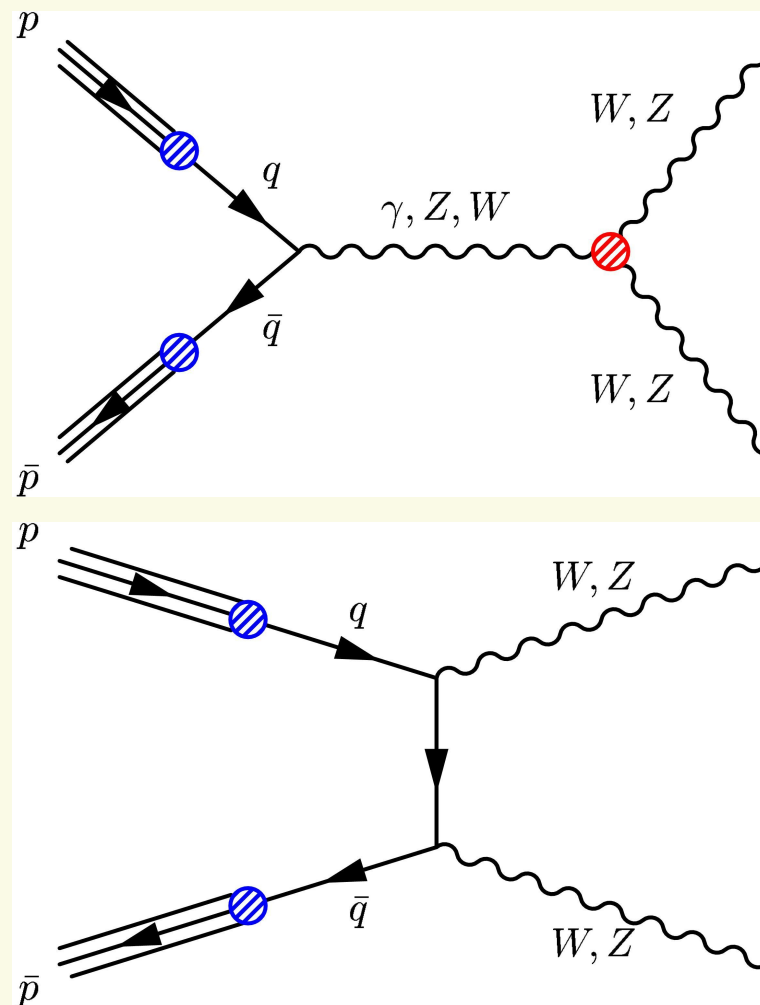

- Direct tests of the unification of the electromagnetic and weak interaction.
- Very sensitive to the mechanism of the symmetry breaking, **i.e. how the  $SU(2)_L \times U(1)_L$  is broken into  $U(1)_{em}$ .**
- Specially interesting in the case of  $Z\gamma$  since the lack of direct couplings in SM: **sensitivity to New Physics in the s-channel.**

## CMS-PAS-EWK-11-009

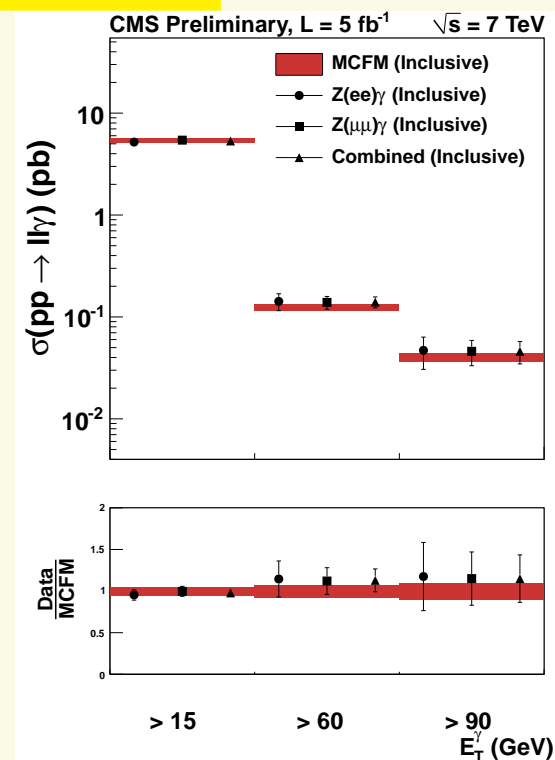
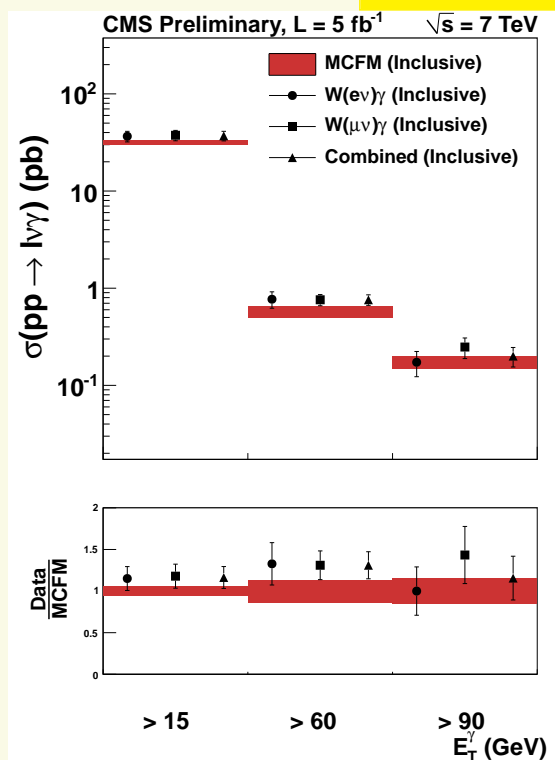

- Very good description of the data by the predictions.
- **Waiting for more statistics to perform very precise studies.**

- This is the weak-diboson process with the highest cross section.
- Since samples are already large, collaborations are performing very detailed comparison with MC-based predictions, including differential distributions.

arXiv:1301.4698

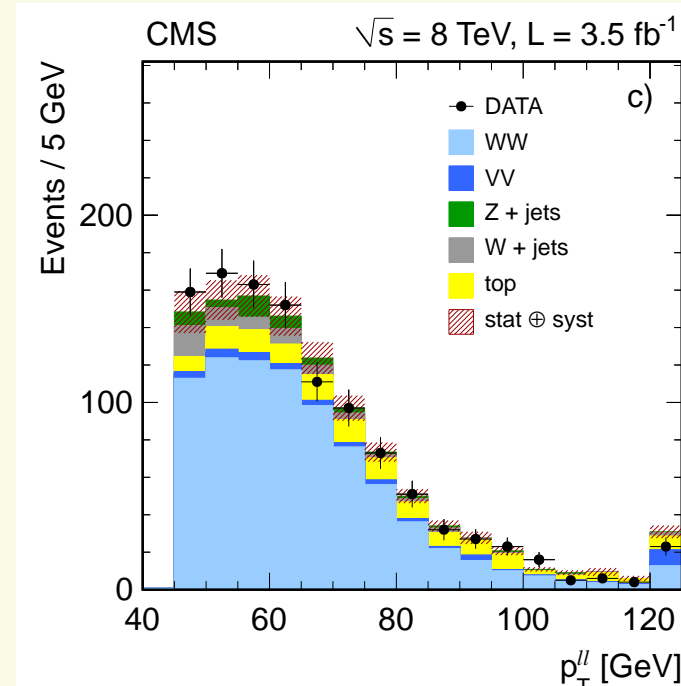
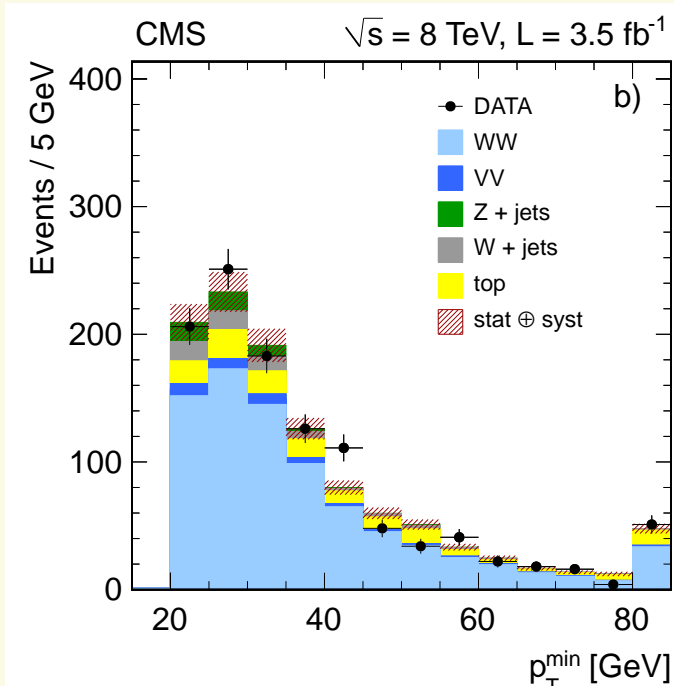
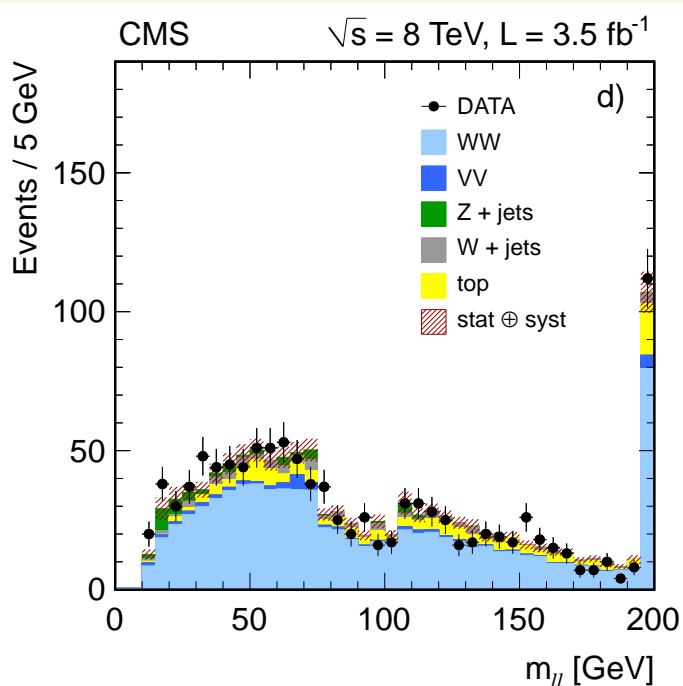

- The measured cross section

$$\sigma_{WW, 8 \text{ TeV}} = 69.9 \pm 2.8(\text{stat}) \pm 5.6(\text{syst}) \pm 3.1(\text{lumi})$$

is a bit higher than the prediction. Also observed at 7 TeV (and by ATLAS).

- Process with the lowest cross section, so very sensitive to possible New Physics affecting the production.
- The four-lepton channel gives a very pure sample, so **it is really a golden channel for discovery.**
- More about this in the third lecture...

## ATLAS-CONF-2012-090

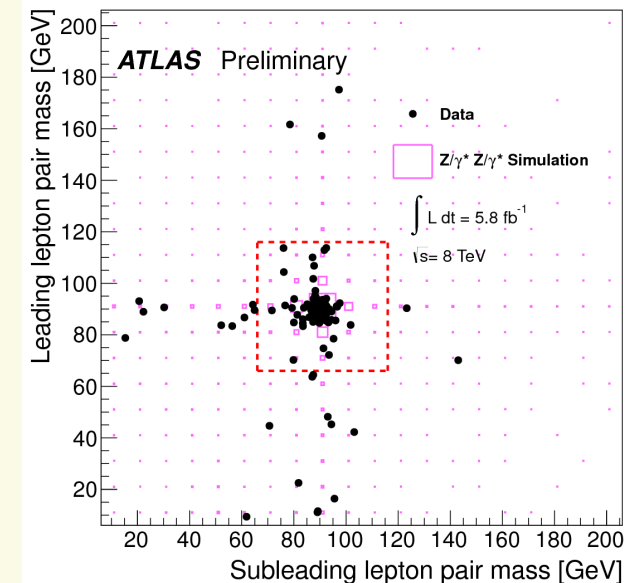
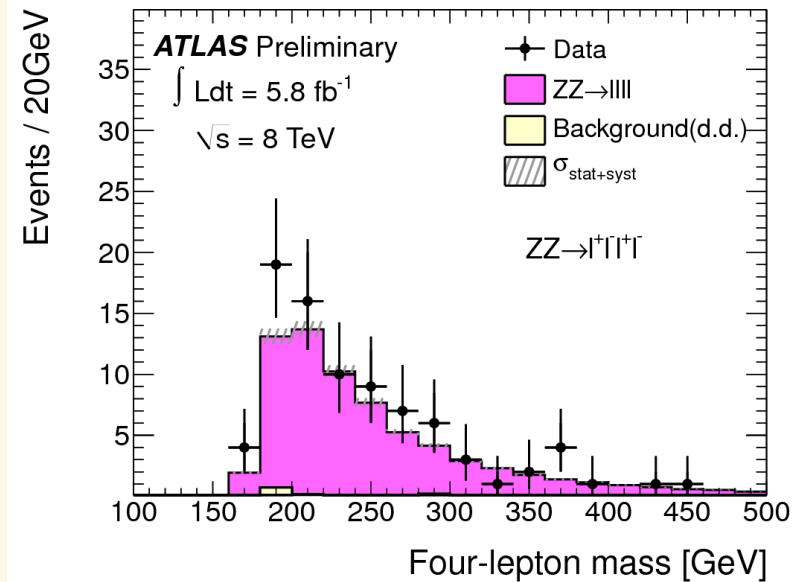
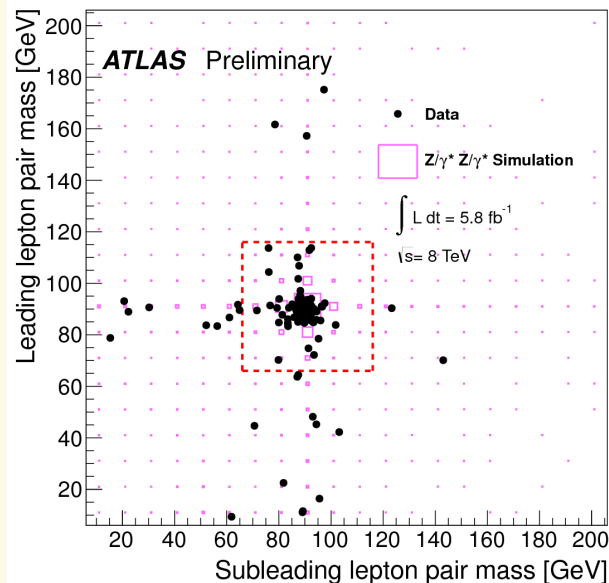

- Cross section is also a bit higher: **(theoretical?) work on this may be needed!**
- Kinematics well reproduced (more data will help).

- Although the leptonic channels are much cleaner due to the low background, the study of semileptonic dibosons is of great interest.

- Specially because the hadronic decays of  $W$  and  $Z$  are not accessible in the inclusive production.

- Resolution is not enough to distinguish  $W$  and  $Z$ , therefore the analysis measures  $WZ$  and  $WW$  altogether.

- Also this analysis is a good check of the  $W$ +dijet background.

- Apart from the hadronic decay, there are also measurements of  $WZ$  production in the fully dilepton channel.

Signature is 3 leptons+MET, which is very important in New Physics (SUSY in particular) searches.

Understanding the kinematics of the events are relevant.

## ATLAS-CONF-2012-157

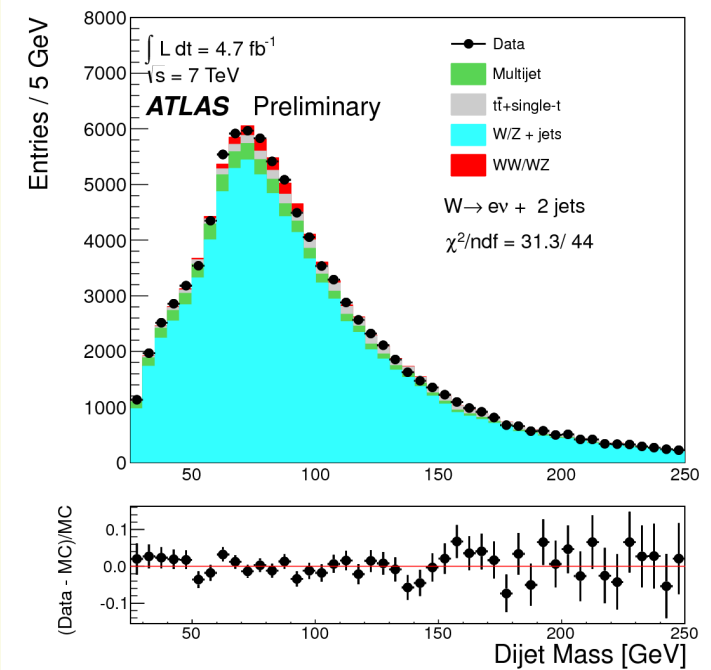

## EPJC 72 (2012) 2173

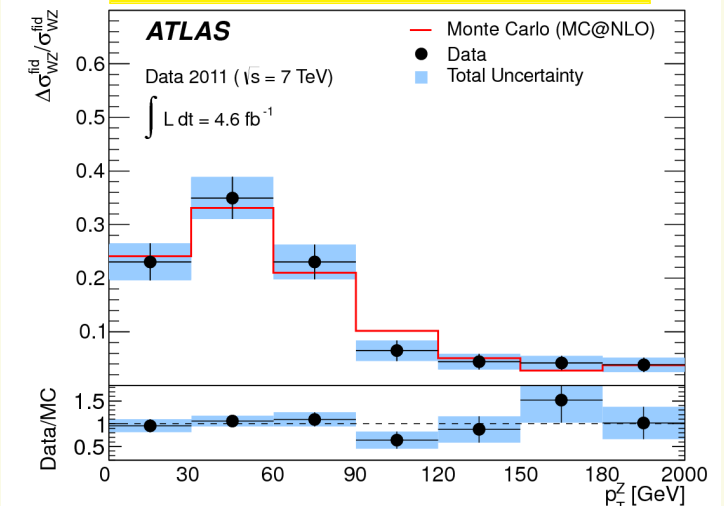

- The QCD and EWK programs of the LHC has developed very quickly bringing big challenges for theory: NNLO, matrix element MC, proton PDFs ...
- They were leading the effort to understand and calibrate the detectors and understand the objects used in the analyses: leptons, jets,...

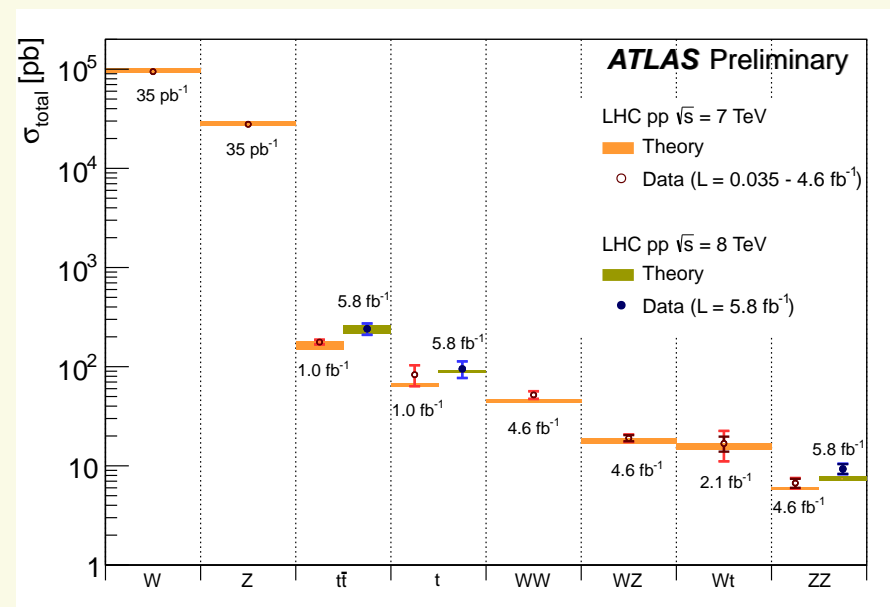
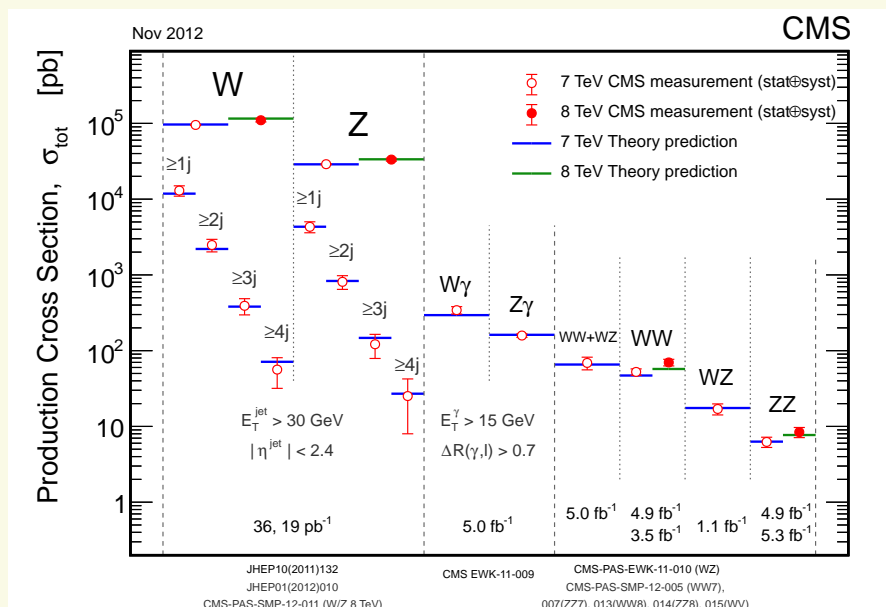

- Even in “discovery mode” they are important since they represent the main backgrounds for any kind of search.
- Low-rate EWK and QCD processes are now becoming accessible, for the first time for precision physics (dibosons, bosons+multiplets) or to be observed (triboson production, VBF production of bosons).



# Results on beauty and charm hadrons



Hadron spectroscopy studies has traditionally been a fundamental source of information for particle physics.

⇒ The most important one for **effects beyond reachable energies.**

⇒ The only (direct) one to **understand quarks (QCD) at low energies.**

In the case of the charmed and beauty hadrons the interest is even broader than before due to the higher masses. We can divide the lines of interest in two big groups **although related**):

- **Understanding quarks in confinement:**

- ⇒ Properties of the bound states (spectroscopy).

- ⇒ High luminosity (and improved detectors) to reach new states.

- ⇒ Comparison with theoretical predictions.

- **Understanding the loop processes:**

- ⇒ Decays branching ratio, interference effects, phases, CKM elements.

- ⇒ Effects given by virtual particles in loops.

- ⇒ Sensitive to physics beyond reachable energies: **New Physics.**



- During the last decade, new baryons containing a bottom quark,  $\Omega_b^-$ ,  $\Xi_b^-$ , discovered but still many states to be found.
- And also the measurements of the properties of the found states (only  $\Lambda_b$  is well studied).
- Since these measurements require large high-purity samples, LHCb provides the most interesting results.

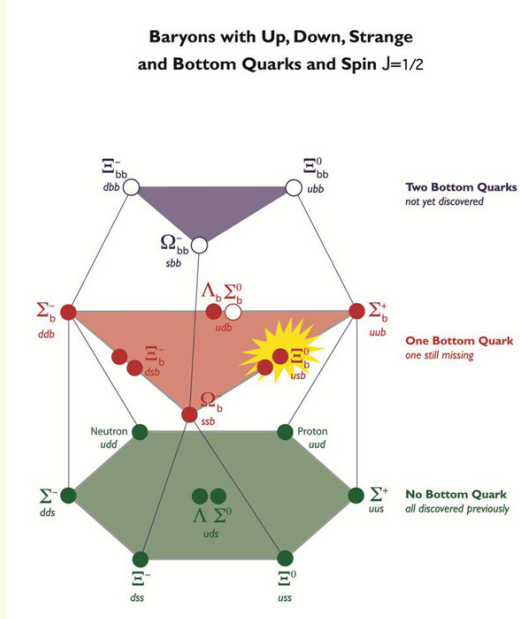

arXiv:1302.1072

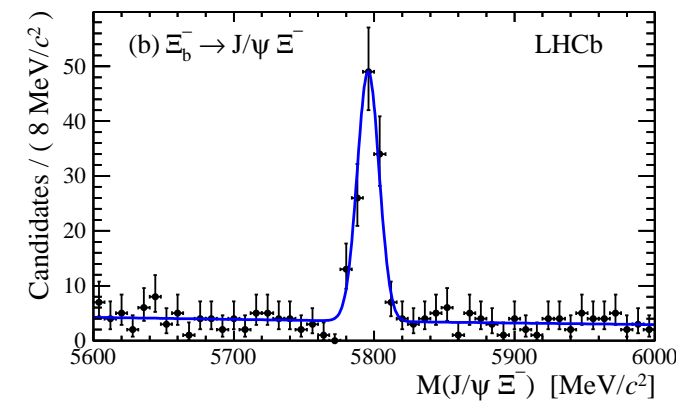
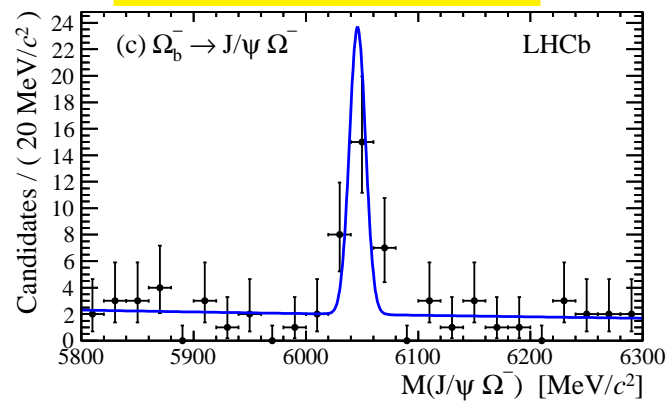
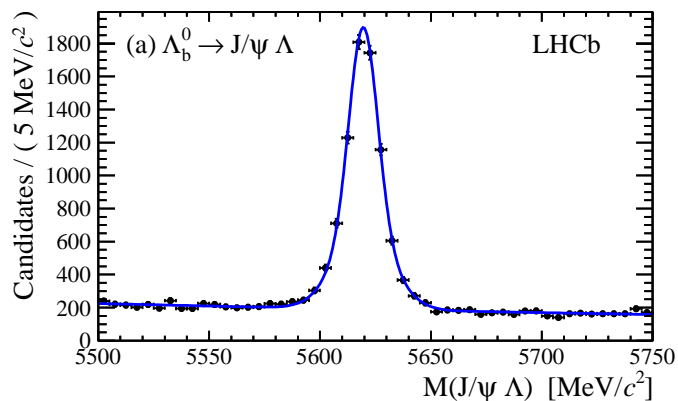

- It requires a very detailed understanding of the detector and the momentum scale, done in two steps: inclusive  $J/\psi \rightarrow \mu\mu$  for relative changes in periods and absolute scale derived from  $B^+ \rightarrow J/\psi K^+$ .
- Most precise mass measurements to date.

- When doing flavour physics, the hadrons we are dealing with are not directly observed in the detector.
- In high- $p_T$  we use jets to “identify” partons and make measurements.
- Now we do physics on hadrons to learn about the constituent partons.
- We need a complete reconstruction of objects, to identify the origin of the observed decay products.
- Several ways used to identify resonances/hadrons:

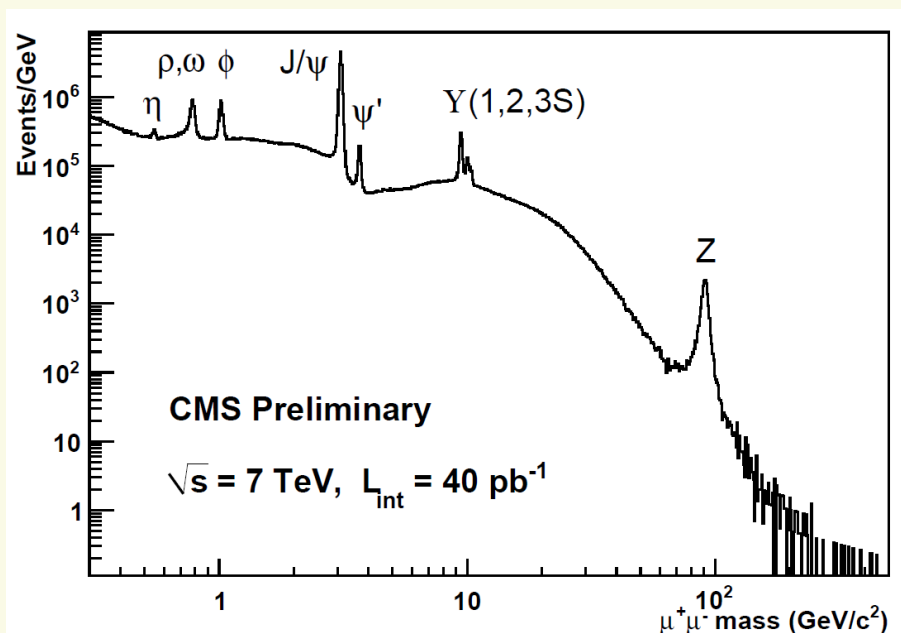

## Leptonic-based decays:

leptons are identified as usual in the detector (but with lower  $p_T$  and from combining them (perhaps with tracks) we identify resonances.

They are very clean, specially fully leptonic channels:  $J/\psi$ ,  $Y$  families.

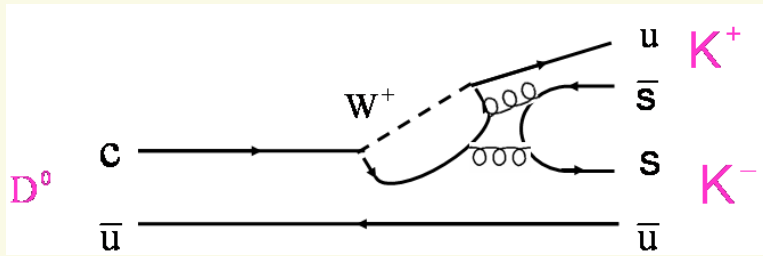

## (pseudo)stable particles ( $K_L, p, \pi, \dots$ ):

virtually stable for our purposes: detected as tracks (or other kind of detector).

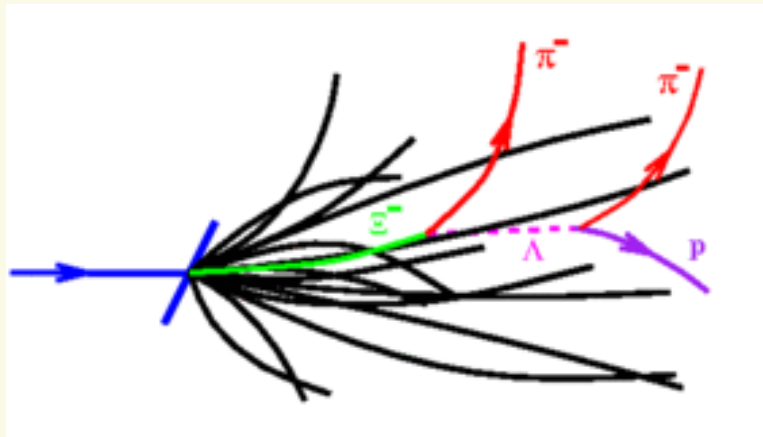

Sometimes we identify even the nature of particle, due to specific detectors sensitive to the differences among them (as in the case of ALICE and LHCb ID-detectors).

## Decaying particles:

reconstructed using the decay products, e.g. as a resonant peak in the invariant mass distribution.

These sometimes are the goal of the study (as in a low-mass version of what happens in high- $p_T$ ).

but commonly are also intermediate states.

(e.g.  $B_s^0 \rightarrow J/\psi \phi \rightarrow \mu^+ \mu^- K^+ K^-$ )

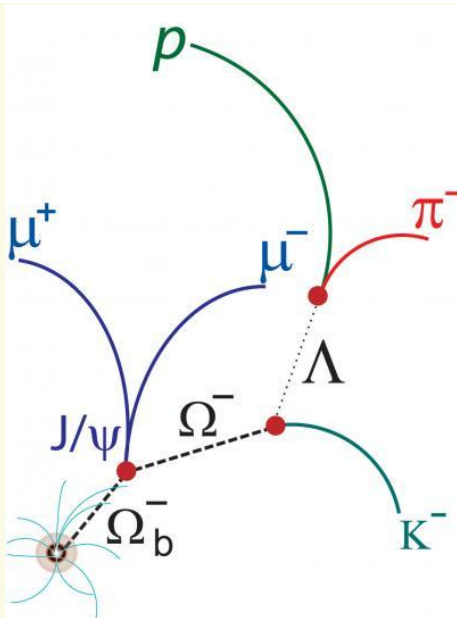



- Aside from the ground states, the understanding of the internal structure of hadrons relies on finding the excited states.

- CMS found the  $\Xi_b^* \rightarrow \Xi_b^\mp \pi^\pm$  state (first baryon and fermion found at LHC) with mass

$$5945.0 \pm 0.7(\text{stat}) \pm 0.3(\text{syst}) \pm 2.7(\text{PDG}) \text{ MeV}$$

- In agreement with the expectation.
- Properties compatible with  $J^P = 3/2^+$ .
- ATLAS has observed a new excited state  $\chi_b(3P)$  in bottomonium family decaying into  $\Upsilon(1S/2S)$  by the emission of a photon.
- Photon reconstructed as a photon or as a conversion (higher precision).
- Nature of some states in the quarkonium families are to be fully understood: 4-quark, cc-gluon, ... ?
- Mass is below the  $B\bar{B}$  threshold, as predicted.

## PRL 108 (2012) 252002

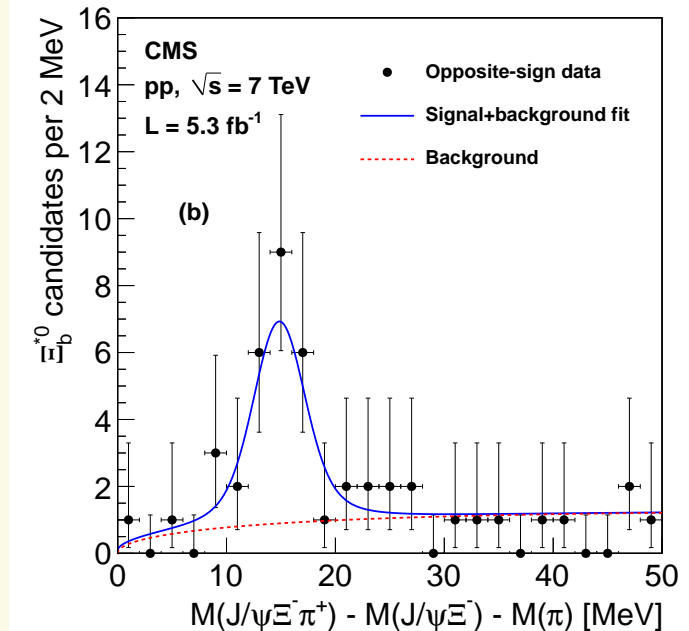

## PRL 108 (2012) 152001

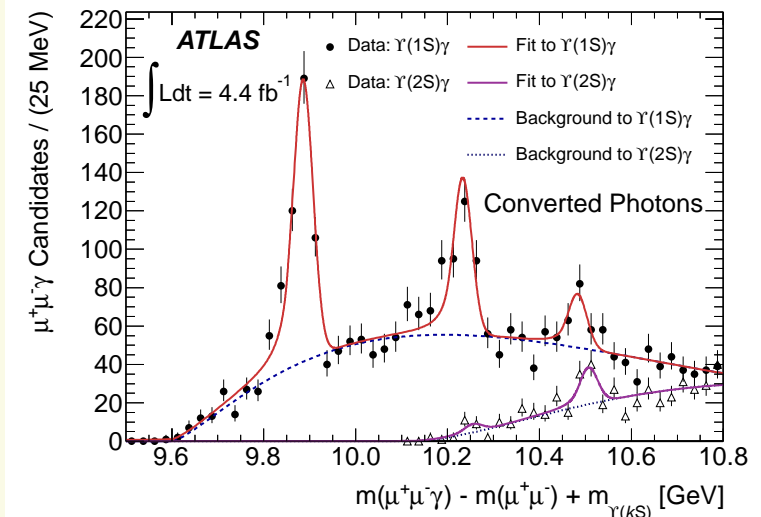

Although the discovery and precision measurements are obtained with (relatively) high branching-ratio decays, **the study of rare decays is also very important:**

- ⇒ Usually involve loop diagrams at the lowest order
- ⇒ They may contain interesting CKM-dependencies
- ⇒ They may be sensitive to the virtual presence of new particles

Among rare decays, the most attractive one is  $B_s/B^0 \rightarrow \mu\mu$  since it is associated to a very clean (theory well under control) and easy final state.

- The branching ratios are expected to be very small **in the SM:**  $\sim 3.5 \cdot 10^{-9}$  and  $\sim 1.1 \cdot 10^{-10}$
- Happening only through loop diagrams (including Cabibbo-suppressed vertices)
- Sensitive to enhancements from New Physics.
- Even beyond the reachable energy.  
(Replace energy by precision/amount of data)

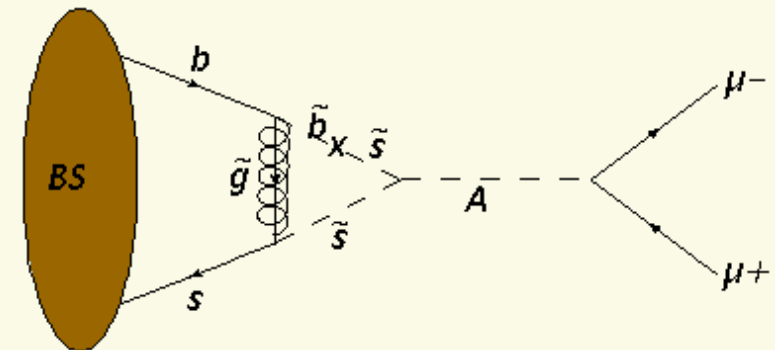
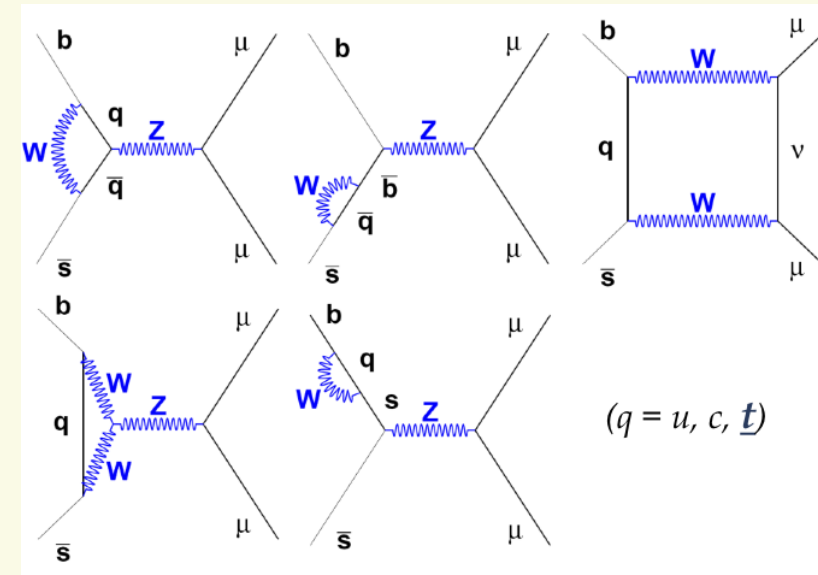

- The search for this signal has been very intense in the last decade at Tevatron (hint seen at CDF?) and LHC.

- Since the large enhancement due to New Physics was not found, the goal was to reach sensitivity to the SM value.

- Finally evidence of it by LHCb for  $B_s$ ,  $B^0$  requires more data.

- The hard steps of the analysis is to know the efficiencies and have under control the calibration and the normalization to other channels ( $B^\pm \rightarrow J/\psi K^\pm$  and  $B^0 \rightarrow K\pi$ )

- The results after developing a sophisticated (BDT-based) analysis are:

$$\mathcal{B}(B_s \rightarrow \mu\mu) \cdot 10^9 = 3.2_{-1.2}^{+1.5} \quad (3.5\sigma)$$

$$\mathcal{B}(B^0 \rightarrow \mu\mu) \cdot 10^9 < 0.94 \quad @ \text{ 95\% CL}$$

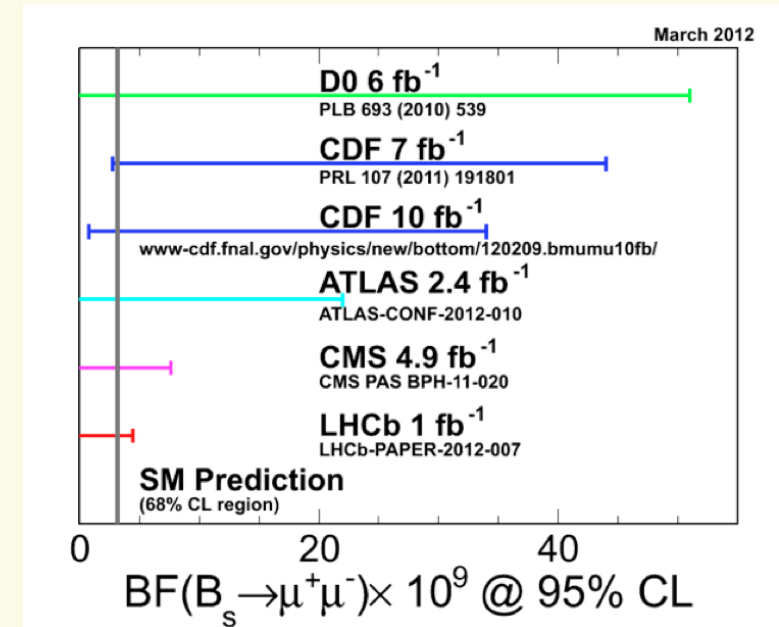

**PRL 110 (2013) 021801**

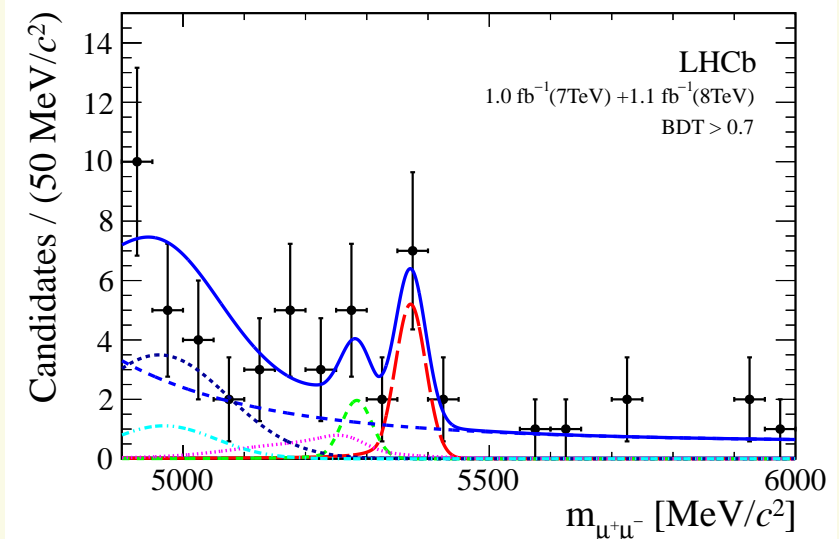



- Another interesting decay to study.
- Branching ratio is not too small ( $\sim 10^{-6}$ ), but the kinematics of the decay is sensitive to the presence of New Physics.
- One is the FB asymmetry as a function of the invariant mass of the muons.

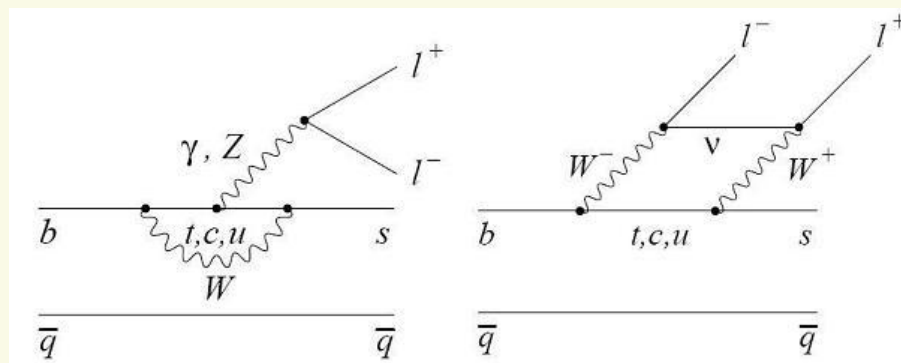

$$A_{FB}(q^2 = m_{\mu\mu}^2) = \frac{N_F - N_B}{N_F + N_B}$$

LHCb-CONF-2012-008

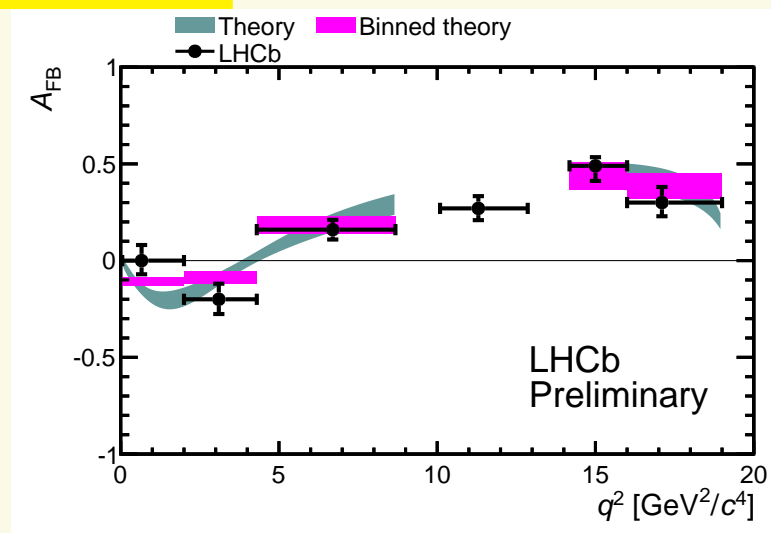
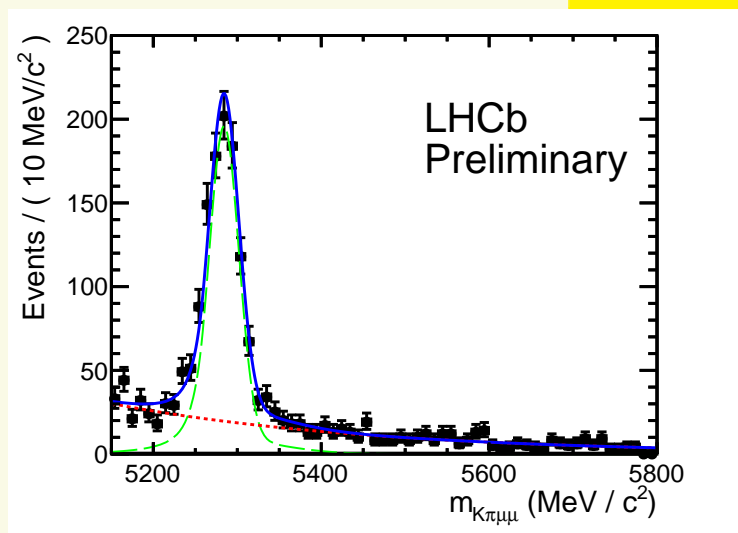

- Good description by SM theory in decay kinematics.
- Zero-crossing point measured at  $4.9^{+1.1}_{-1.3} \text{ GeV}^2$



- For neutral mesons, flavour eigenstates may be different from mass eigenstates.
- Therefore during his lifetime, a meson change nature following:

$$i \frac{d}{dt} \begin{pmatrix} |B^0\rangle \\ |\bar{B}^0\rangle \end{pmatrix} = \left[ \begin{pmatrix} M_{11} & M_{12} \\ M_{12}^* & M_{22} \end{pmatrix} - \frac{i}{2} \begin{pmatrix} \Gamma_{11} & \Gamma_{12} \\ \Gamma_{12}^* & \Gamma_{22} \end{pmatrix} \right] \begin{pmatrix} |B^0\rangle \\ |\bar{B}^0\rangle \end{pmatrix}$$

where the mass eigenstates are  $|B_{L,H}^0\rangle = p|B^0\rangle \pm q|\bar{B}^0\rangle$  being  $\frac{p}{q} = \sqrt{\frac{M_{12}^* - \frac{i}{2}\Gamma_{12}^*}{M_{12} - \frac{i}{2}\Gamma_{12}}}$

- This mixing and oscillations are well established for the  $K^0$ ,  $B^0$  and  $B_s^0$  and it is becoming accessible for the  $D^0$ .

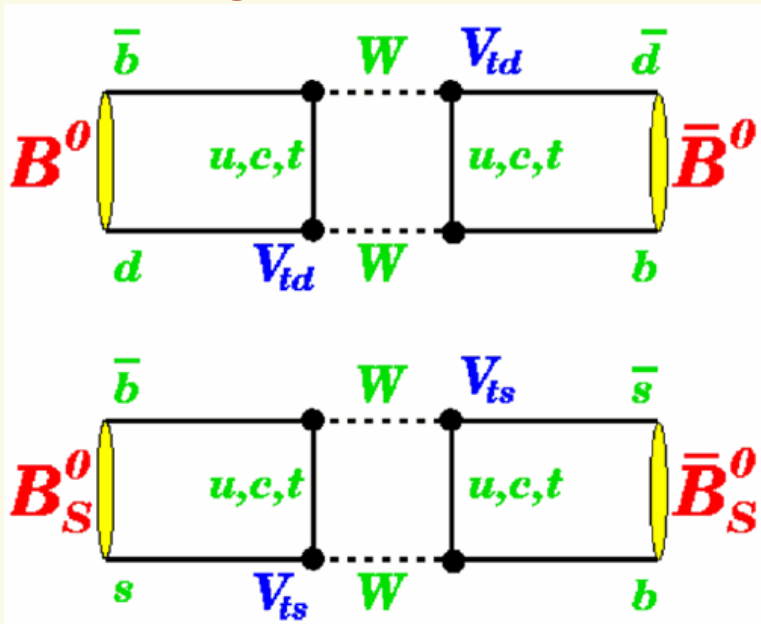

But it is far from being a trivial measurement:

⇒ Requires “to know” which meson is produced and compare with the observed one.

(requires to tag the nature of the produced meson that is not directly accessible)

⇒ Oscillations properties requires doing that job as a function of the lifetime

(since we only know the nature of the meson when it decays)

- Although well established in the  $B^0$  system, the measurement of the properties related to the mixing is always interesting to improve our knowledge.
- Specially because the parameters that are relevant for the theory are not easy to measure from the observed quantities (large uncertainties).
- So try to use as many channels (and different) as possible.
- New measurement using  $B^0 \rightarrow D^- \pi^+$  and  $B^0 \rightarrow J/\psi K^{*0}$ .

arXiv:1210.6750

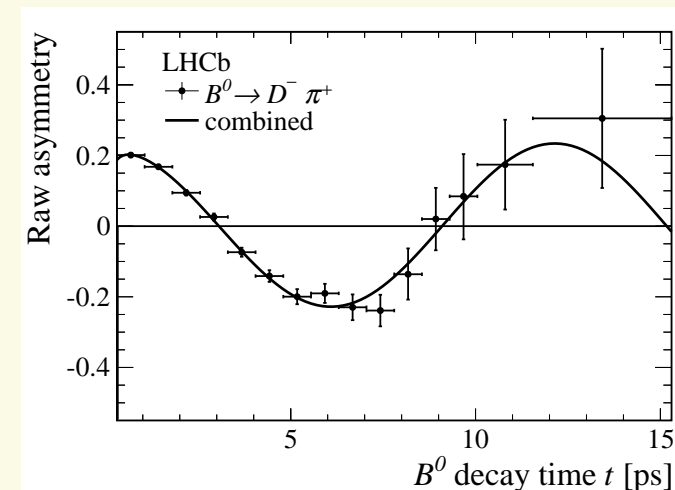
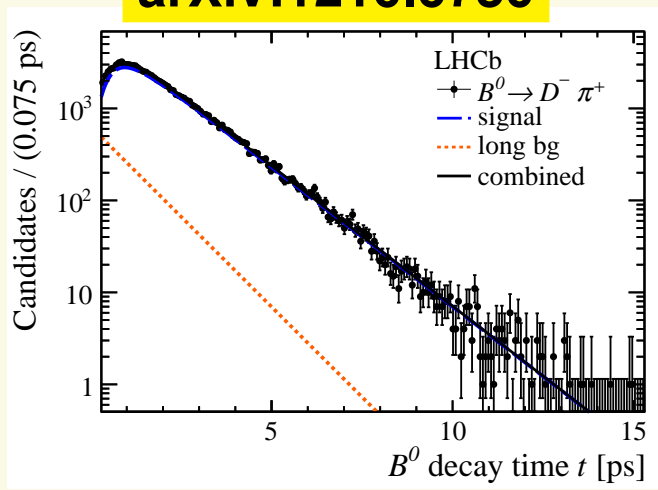
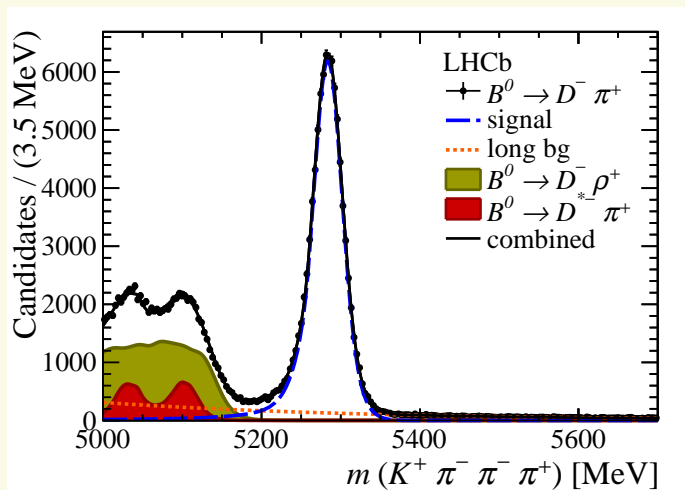

- Most precise measurement of  $\Delta m(B^0)$ , difference in mass between the two eigenstates:

$$\Delta m(B^0) = 0.5156 \pm 0.0051(\text{stat}) \pm 0.0033(\text{syst}) \text{ ps}^{-1}$$

- **Mixing in charm sector is becoming accessible now due to large samples collected in B factories and hadron colliders.**
- **Its study is fundamental since it is unexplored (surprises?) and it is the only up-type quark in which we may study for mixing and CP violation.**
- **Exploit interference between the mixing and the doubly-Cabibbo-suppressed decay amplitudes in  $D^0 \rightarrow K\pi$**

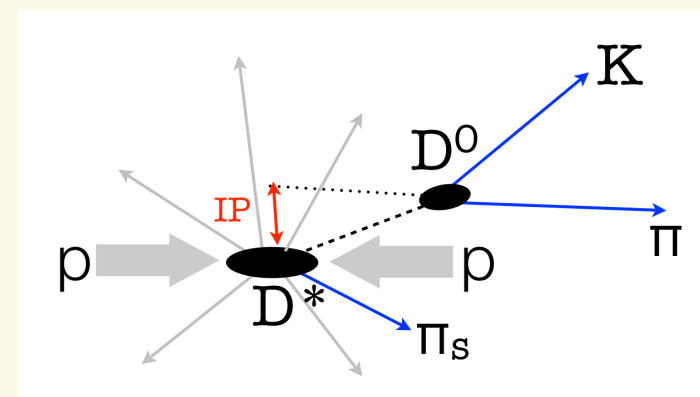
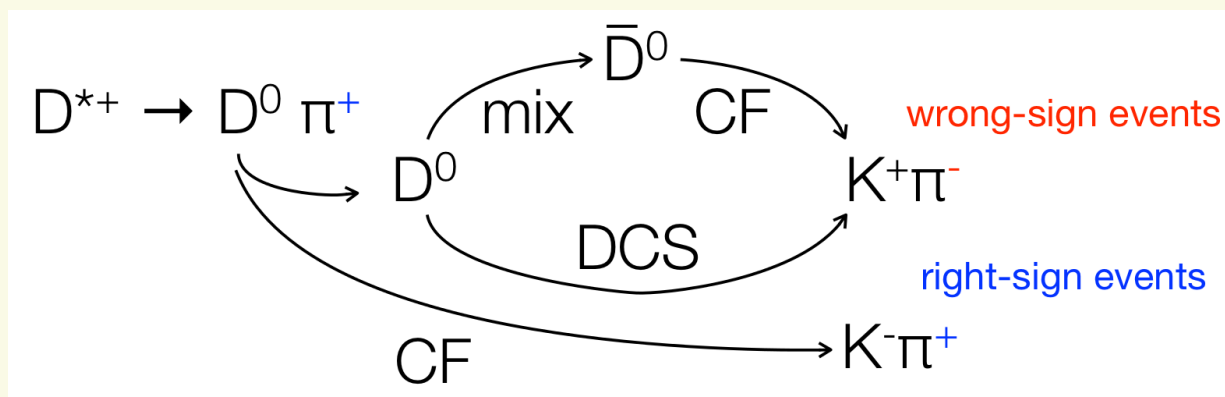

- **The quantity that is measured is the ratio of wrong-sign (sensitive to the mixing) to right-sign (not sensitive to mixing) candidates as a function of the lifetime.**
- **Using  $D^0$  coming from  $D^*$  so the slow  $\pi$  allows to tag the produced  $D^0$ .**

- The most challenging part of the analysis is to keep the systematics low, specially those influencing the time dependence of the ratio.
- Secondary decays and backgrounds peaking in  $m(D^0\pi_s)$ .

arXiv:1211.1230

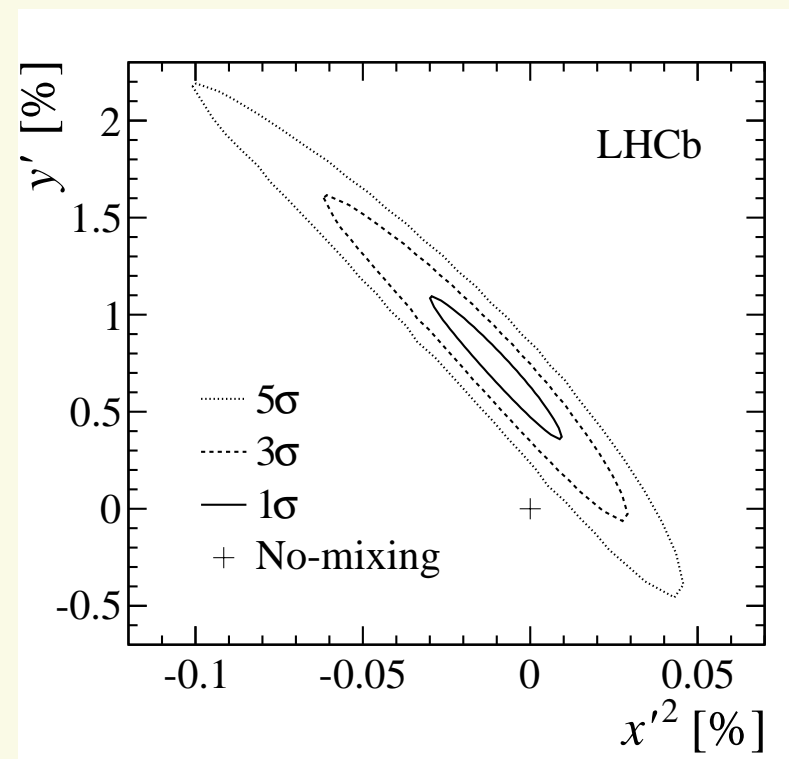
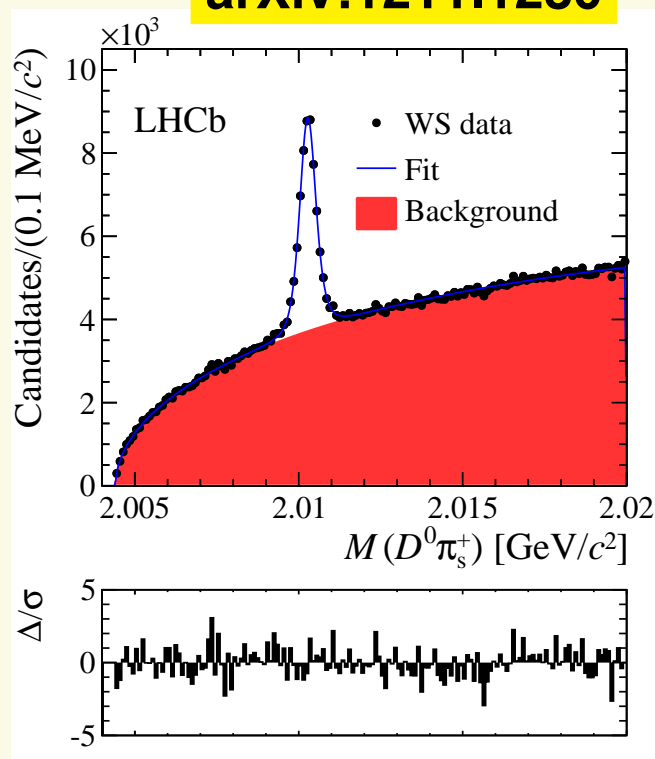
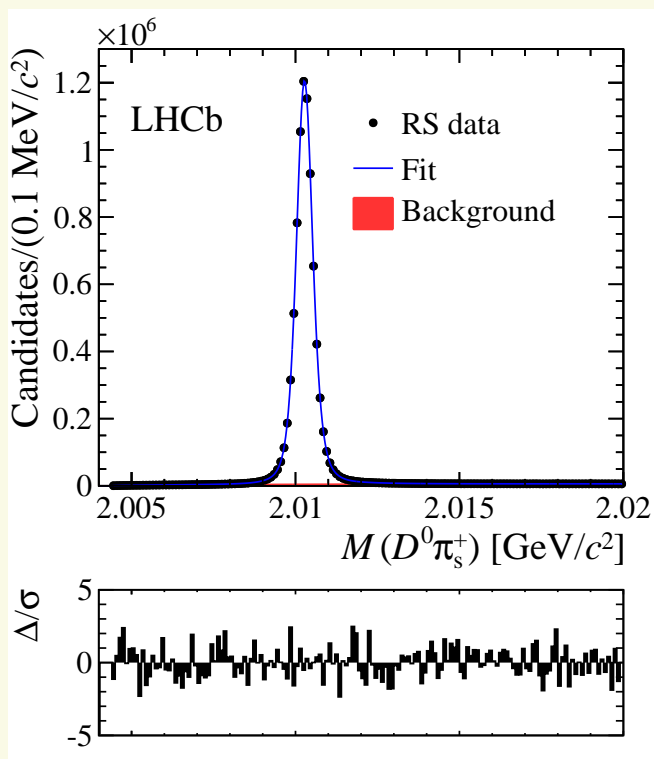

- The no-mixing hypothesis is **excluded at  $9.1\sigma$**  with this measurement.

**First observation from a single measurement**

- In agreement with previous results from several experiments (B factories, CDF)



- The Cabibbo-Kobayashi-Markawa (CKM) quark mixing matrix relates the mass eigenstates and the flavour eigenstates.
- It is fully given by three mixing angles and one complex phase, but they appear within the matrix elements.

$$\begin{pmatrix} d' \\ s' \\ b' \end{pmatrix} = \begin{pmatrix} V_{ud} & V_{us} & V_{ub} \\ V_{cd} & V_{cs} & V_{cb} \\ V_{td} & V_{ts} & V_{tb} \end{pmatrix} \begin{pmatrix} d \\ s \\ b \end{pmatrix} = V_{CKM} \begin{pmatrix} d \\ s \\ b \end{pmatrix}$$

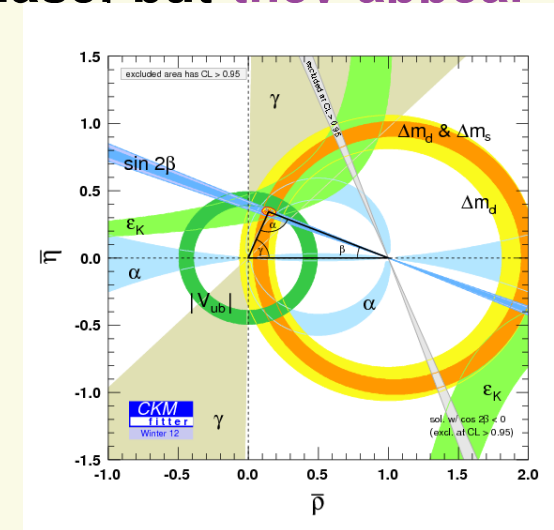
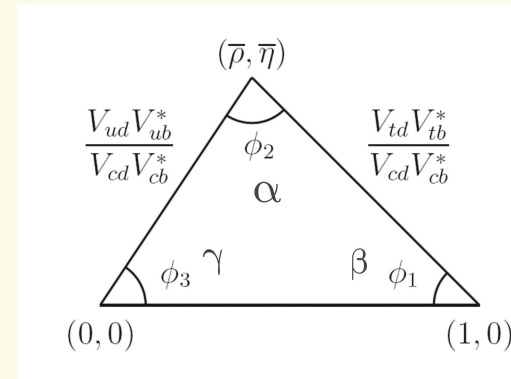

**Ideally:** measure each element independently (confirms matrix).

**In practice:** only possible to measure combinations of elements.

The unitarity condition of the matrix allows to represent combinations of elements (rows and columns) as a triangle, whose area is related to the CP violation.

- Three types of CP violation:

**Direct (decay):**  $(A \rightarrow f) \neq (\bar{A} \rightarrow \bar{f})$

**Indirect in mixing:**  $(A \rightarrow \bar{A}) \neq (\bar{A} \rightarrow A)$

**Indirect in interference between mixing and decay:**  $(A \rightarrow \bar{A} \rightarrow f) \neq (\bar{A} \rightarrow A \rightarrow f)$



- Measurements on **decays with loops may be sensitive to New Physics**, so measurements from tree processes are important to have clean SM values.
- LHCb has performed several measurements using  $B^\pm \rightarrow D^0 K^\pm$ , which is sensitive to  $\gamma$  in the interference of the two diagrams

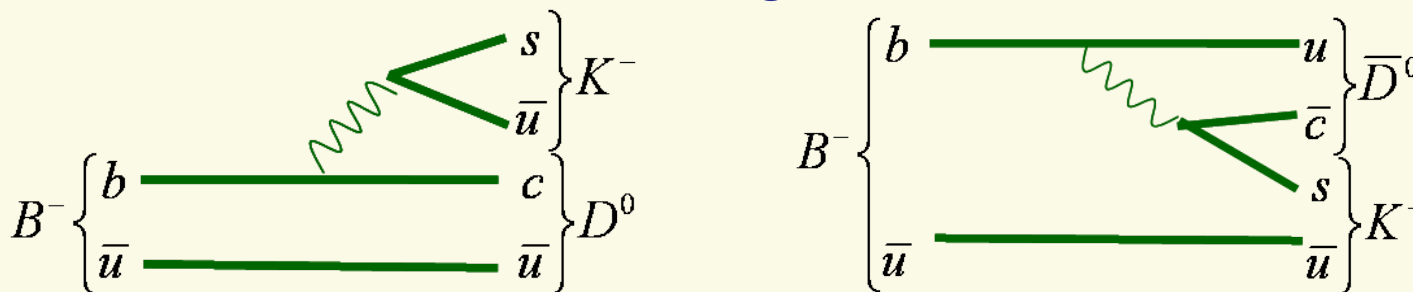

- But only in  $D^0$  decays that are common between  $D^0$  and  $\bar{D}^0$ : **CP eigenstates** ( $KK, \pi\pi$ ) or including Cabibbo suppressed (having low Branching ratios)
- So need to perform measurements of the involved branching ratios for  $B^+$  and  $B^-$  and compute asymmetries.
- Out of the combination of the various analyses:

$$\gamma = (71.1^{+16.6}_{-15.7})^\circ$$

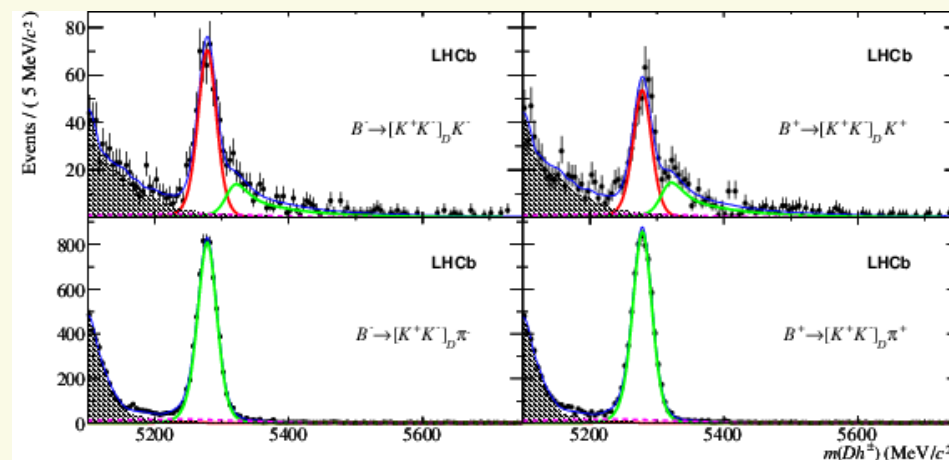

In agreement (and with comparable uncertainty) to the World Average.

- LHCb used the 3-body charmless (no net strangeness) decays of the  $B^\pm$  for CPV:

$$B^\pm \rightarrow \pi^\pm \pi^+ \pi^-$$

$$B^\pm \rightarrow K^+ K^- \pi^\pm$$

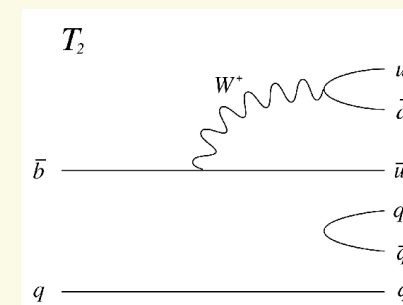
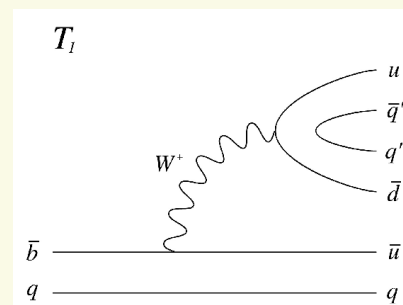
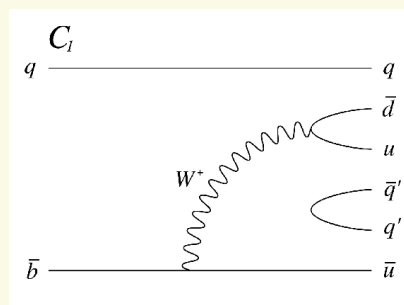

- These are sensitive to transitions between 1<sup>st</sup> and 2<sup>nd</sup> generation.
- Observed asymmetry is opposite in  $\pi^\pm \pi^+ \pi^-$  (enhancement for  $B^-$ ) with respect to  $K^+ K^- \pi^\pm$  (enhancement for  $B^+$ ).

## LHCb-CONF-2012-028

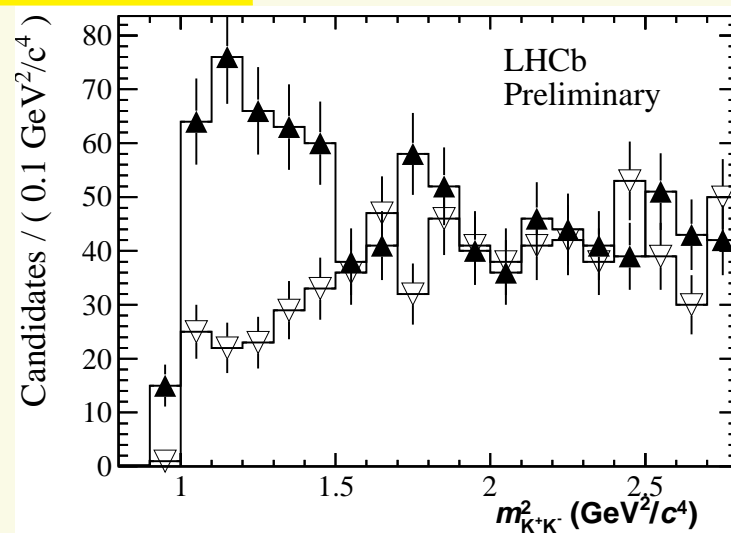
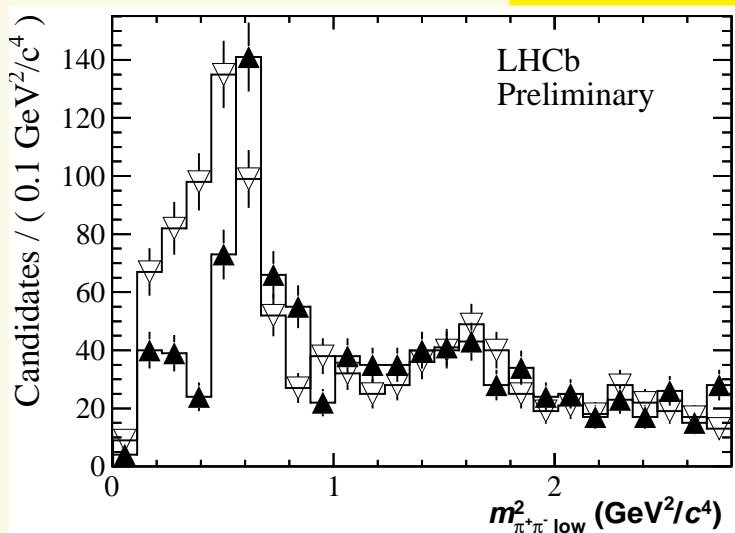

- Some kinematic regions show a large and significant local asymmetry.





- The process  $B_s \rightarrow J/\psi\phi$  is very important since it is sensitive to New Physics affecting the CP violation.

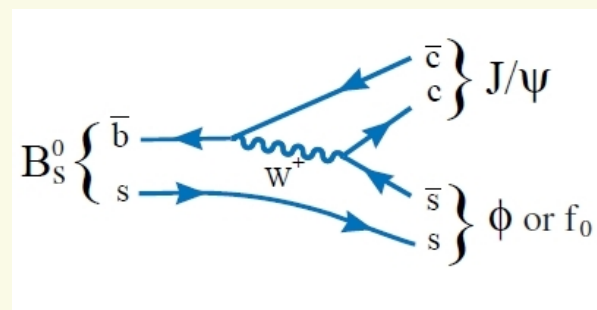
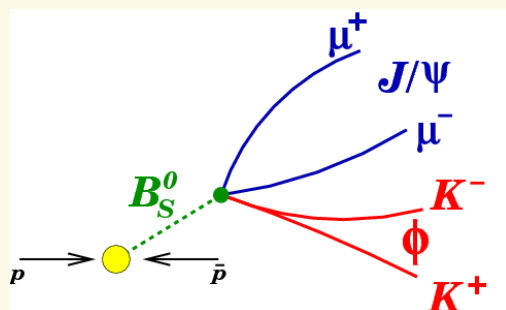

- CP Violations occurs due to interference between direct decays and decays occurring through mixing.
- Characterized through the mixing phase,  $\phi_s$  (in SM  $\sim (-2\beta)$  of the CKM)
- Experiments at the LHC and Tevatron are studying the properties of this decay and the related parameters, specially those involving the CP Violation.
- All measurements are in agreement and compatible with the SM value. Results usually presented in the  $\phi_s - \Delta\Gamma_s$  plane.
- LHCb made the first observation of the width difference (for mass eigenstates) being non-zero.

LHCb-CONF-2012-002

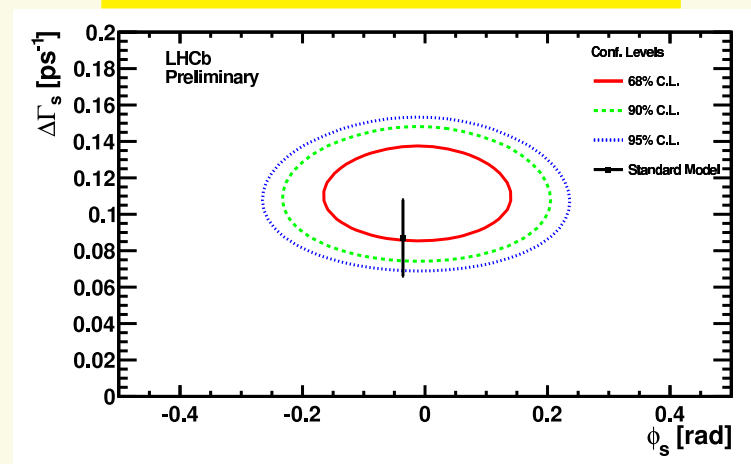

$$\Delta\Gamma_s = 0.116 \pm 0.018(\text{stat}) \pm 0.006(\text{syst}) \text{ ps}^{-1}$$



- LHCb measured (PRL 108 (2012) 111602) CP Violations in charm decays, confirmed by other experiments afterwards.
- A bit unnatural for the SM: most of the predictions expected (almost) no violation.
- In order to cancel momentum and charge dependences of the particle ID, the quantity that is relevant is

$$\Delta A_{CP} = A_{CP}(D \rightarrow KK) - A_{CP}(D \rightarrow \pi\pi)$$

- Turned to be significantly different from zero:

$$\text{LHCb: } \Delta A_{CP} = (-0.82 \pm 0.21(\text{stat}) \pm 0.11(\text{syst}))\%$$

$$\text{World Average: } \Delta A_{CP} = (-0.65 \pm 0.18)\%$$

- Analysis requires to tag the  $D^0$ , which is done as in the measurement of the  $D^0$  oscillations, so experimental analysis is very clean.
- Theoretical calculations are difficult: naïve estimations may be an underestimate.
- But the central value seems still pretty high.

This result is clearly another one more intriguing measurement from heavy-flavour physics that could be pointing to something outside the SM.



- LHC has ended the “run 1” successfully.
- Experiments have performed very well in **the new energy and luminosity regime.**
- Results already confirmed that the (known) SM is still alive!
  - Lots of QCD-related measurements, already more precise than theoretical predictions.
  - New physics is not affecting the dominant processes at LHC.
  - Predictions limiting sensitivities... use data to help theoretical paths.
  - Should the theoretical/phenomenological effort be moved to improve SM (QCD) predictions before we might find new physics?

**Half true half joke...**

- However, the impressive agreements give a lot of confidence
  - We should congratulate theoretical work in the last decade(s).
  - It is already paying back... and it is part of the LHC success.
  - Fundamental to have this confidence to go beyond the SM and precision measurements on previously unreachable quantities.



- **EWK Physics has started a new era:**

- Inclusive boson production passed as benchmark.
- Multiboson production is the new reference point: The race for tribosons is on!
- Diboson production in precision era... everything ok?
- Similarly with QCD radiation in boson production.

- **Flavour Physics reached new levels of precision**

- Many (never too many) measurements on charm and bottom.
- Completing knowledge on spectroscopic structures for heavy quarks.
- No surprises yet, but this is just the (impressive) beginning.
- Long-sought measurements already available:  $B_s \rightarrow \mu\mu$  measured!
- Other results not really disagreeing, but are clearly intriguing: more data and precision!

Now that SM-related homework is done and we are happy with the outcome, it is time to go beyond that and question

**what's going on in the region where nobody looked before?**

(for the answer... the other two lectures)

