

LLRF systems for future X-band test stands

J. Kovermann, S. Rey, L. Timeo

27.09.2012

Outline

- Overview of existing LLRF system (X-box 1)
- Performance limitations of X-box 1 LLRF
- Scalability of X-box 1 LLRF
- Two alternative proposals for LLRF upgrades
- Cost overview of existing and proposed LLRF

X-box 1 LLRF

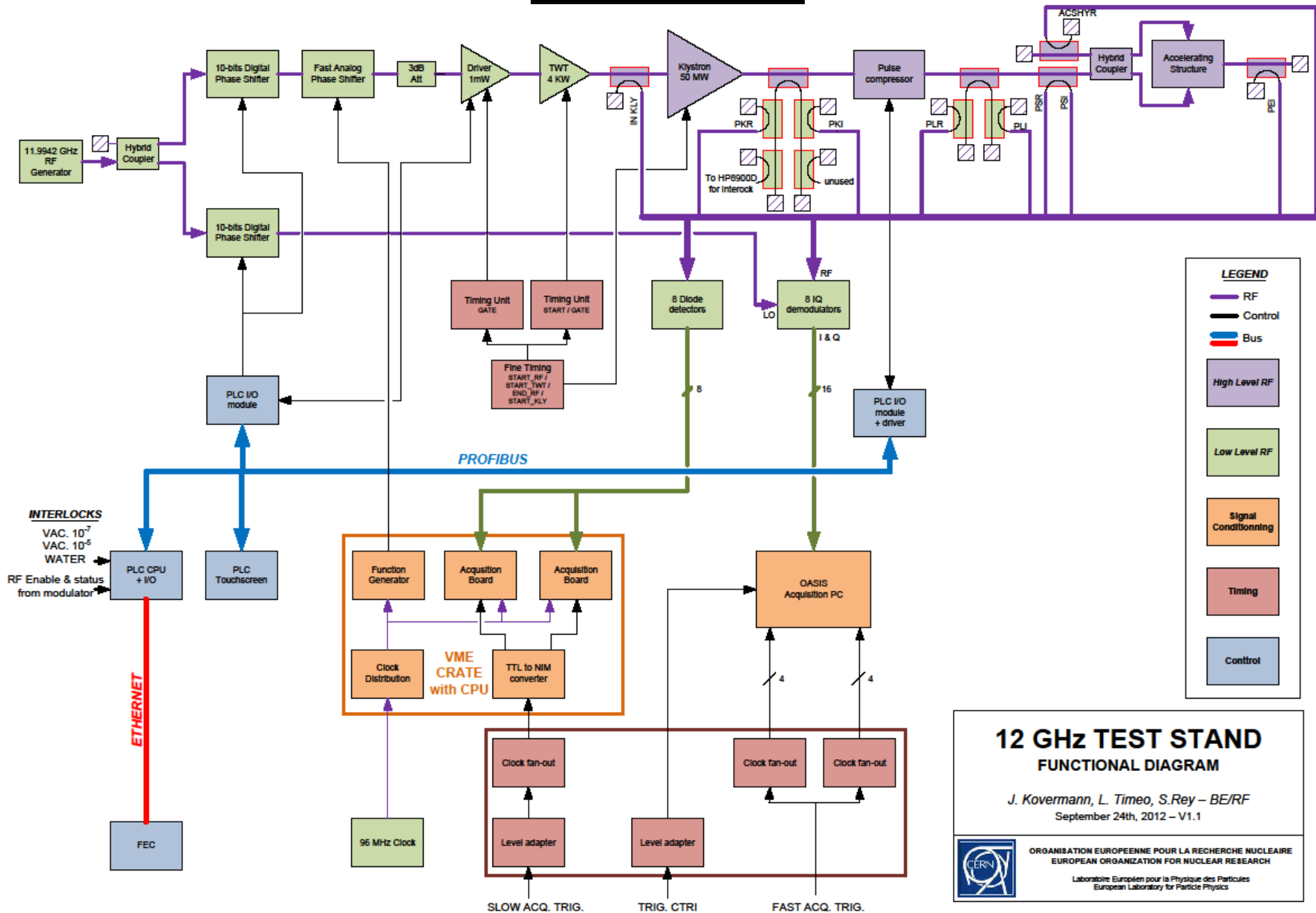

12 GHz TEST STAND FUNCTIONAL DIAGRAM

J. Kovermann, L. Timeo, S.Rey – BE/RF
September 24th, 2012 – V1.1



ORGANISATION EUROPEENNE POUR LA RECHERCHE NUCLEAIRE
EUROPEAN ORGANIZATION FOR NUCLEAR RESEARCH

Laboratoire Européen pour la Physique des Particules
European Laboratory for Particle Physics

Performance limitations of existing LLRF

- Poor measurement performances with diodes and IQ demodulators
- Request for higher bandwidth and dynamic range from structure test and breakdown physics side
- Complexity → difficult to adjust and maintain
- Poor timing performances (jitters)
- Need CERN infrastructure

Scalability of existing LLRF

- LLRF system strongly depends on CERN control system software and hardware
- ➔ Difficult to export to possible outside test stands
- No need for synchronization of future test stands to CTF2 (X-box 1 will provide synched power for dog-leg experiment)
- Easy software modification desirable for flexible conditioning and structure test schemes

LLRF proposal #1

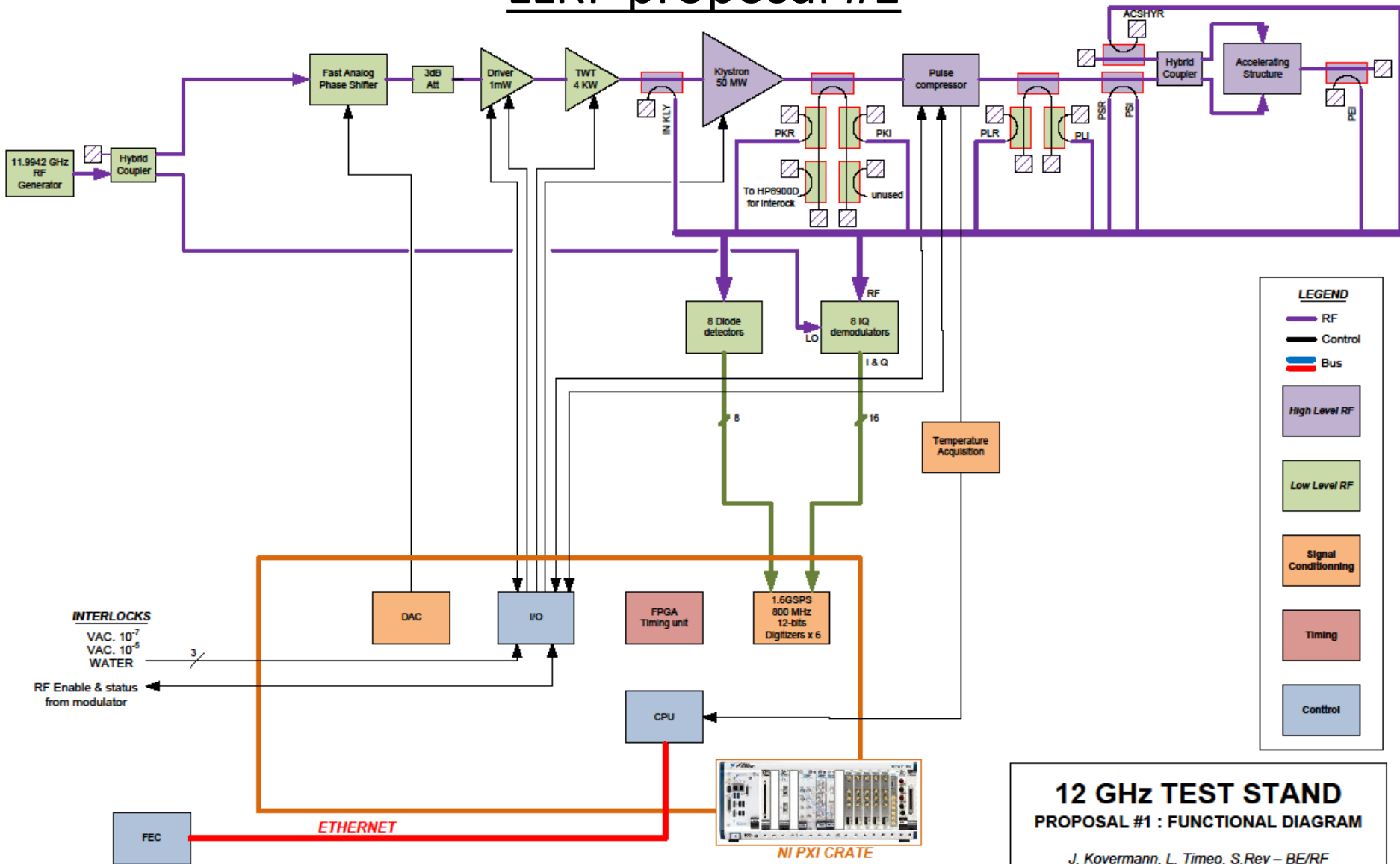

LEGEND

- RF (Purple line)
- Control (Black line)
- Bus (Red/Orange line)
- High Level RF (Purple box)
- Low Level RF (Green box)
- Signal Conditioning (Orange box)
- Timing (Red box)
- Control (Blue box)

**12 GHz TEST STAND
PROPOSAL #1 : FUNCTIONAL DIAGRAM**

J. Kovermann, L. Timeo, S.Rey – BE/RF
September 24th, 2012 – V1.0

ORGANISATION EUROPEENNE POUR LA RECHERCHE NUCLEAIRE
EUROPEAN ORGANIZATION FOR NUCLEAR RESEARCH

Laboratoire Européen pour la Physique des Particules
European Laboratory for Particle Physics



Details of proposal #1

- Driver chain similar to X-box 1
- Timing and analogue phase shifter DAC implemented in PXI
- Interlocks handled by PXI FPGA board
- Needs synthesizer 12GHz cw source
- I/Q fast sampling by PXI digitizer boards
- ➔ Conservative LLRF hardware approach, but still fully decoupled from control system

LLRF proposal #2

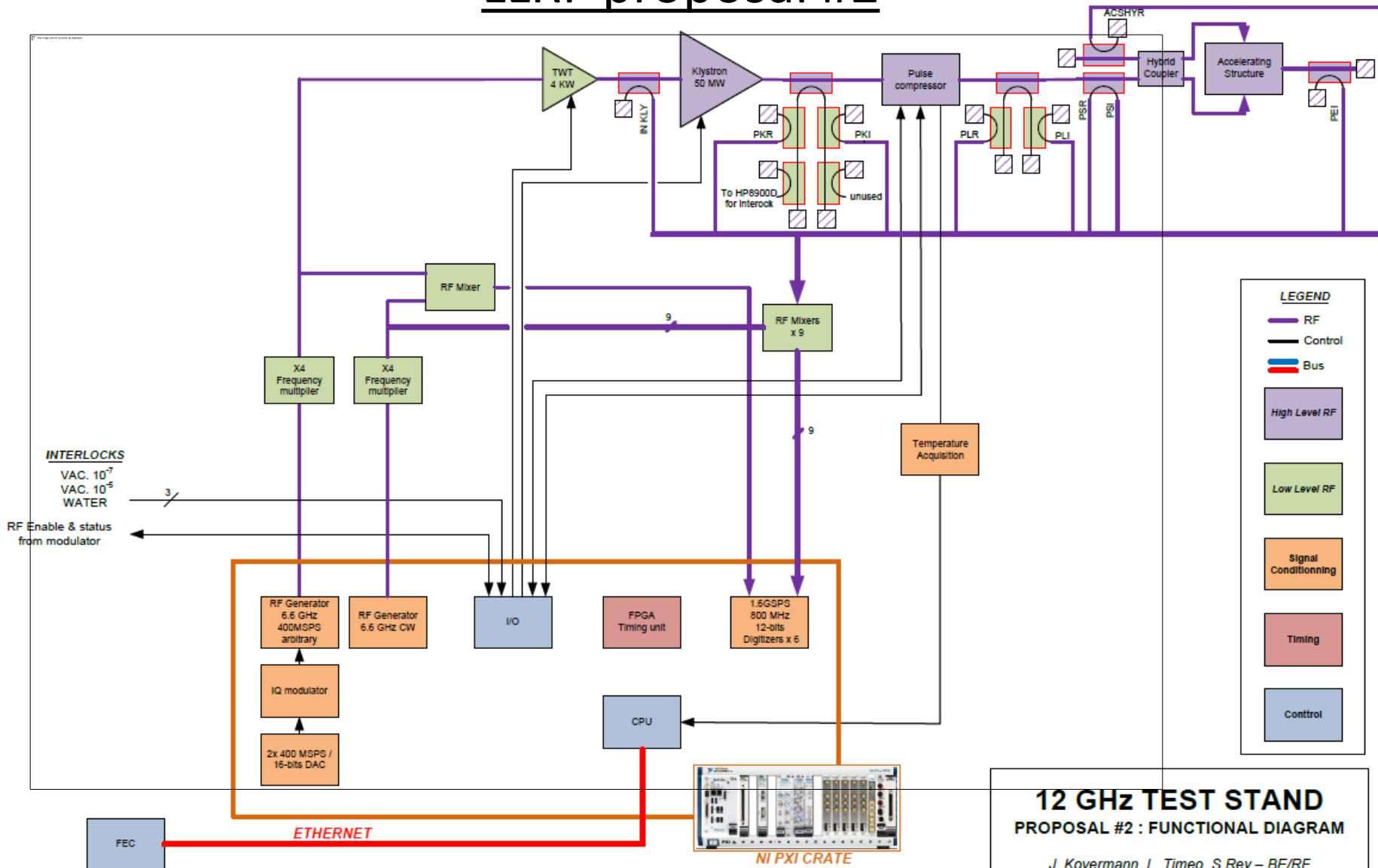

12 GHz TEST STAND
PROPOSAL #2 : FUNCTIONAL DIAGRAM

J. Kovermann, L. Timeo, S.Rey – BE/RF
 September 24th, 2012 – V1.0

 ORGANISATION EUROPEENNE POUR LA RECHERCHE NUCLEAIRE
 EUROPEAN ORGANIZATION FOR NUCLEAR RESEARCH

Laboratoire Européen pour la Physique des Particules
 European Laboratory for Particle Physics

Details of proposal #2

- Implementation of driver chain in PXI
 - ➔ I/Q modulated 3GHz signal multiplied x4
- Fast direct IF sampling after downmixing of 12GHz signals to 400MHz IF, I/Q demodulation in software (FPGA)
- Expecting higher dynamic range and less calibration problems, I/Q modulator based driver chain extremely interesting for feedback systems, but needs more development on LLRF and software side

Cost and development time estimation

- Both proposals need evaluation/tests (1-2 months), evaluation hardware and support for PXI software will be provided by NI
- LLRF hardware development by LLRF group
- Software development strongly supported by J. Tagg (NI)
- Future software support by EN-ICE group at CERN

LLRF proposal #1 cost comparison

NI

Pos.	Qty.	Part Number and Description	Price	Discount	Unit Price	Amount	Currency
1	1	780291-01 PXIe-1075, 18-Slot 3U PXI Express Chassis	6399.00	10%	5759.10	5759.10	\$
2	1	763830-01 Power Cord, AC, U.S., 125VAC, 15A	19.00	10%	17.10	17.10	\$
3	1	782340-04 NI PXIe-8135 Core I7-9610QE 2.3GHz Controller, Win 7 (32-bit)	5349.00	10%	4994.10	4994.10	\$
4	1	860903-02 NI Standard System Assurance Program for PXI	8190.00	-	8190.00	8190.00	\$
5	1	778274-01 NI PXI-4070 6 1/2 Digit FlexDMM (1.8 MS/s Digitizer, 300 V, 1 A)	2059.00	10%	1853.10	1853.10	\$
6	1	777697-01 NI PXI-2503 24 ch Relay Multiplexer and Matrix Switch	1183.00	10%	1064.70	1064.70	\$
7	5	782097-01 NI 5772 (-01) 2-Channel, 1.6 GS/s, 12-Bit, AC-Coupled, No Antialias Filter Digitizer Adapter Module for NI FlexRIO	6499.00	10%	5849.10	29245.50	\$
8	1	778964-01 NI PXI-6515 Industrial 32 Source/Sink DI, 32 Sink DO Bank Isolated Digital I/O Module and NI-DAQ	479.00	10%	431.10	431.10	\$
9	6	781205-01 NI PXIe-7961R NI FlexRIO FPGA Module (Virtex-5 SX30T)	4499.00	10%	4049.10	24294.60	\$
10	1	781287-02 NI 5761 250 MS/s, Digitizer Adapter Module for NI FlexRIO (DC)	5149.00	10%	4634.10	4634.10	\$
11	1	777878-01 TB-2605 Multiplexing terminal block and analog bus plug kit for use with the NI 2501 and the NI 2508 switches for PXI.	215.00	10%	193.50	193.50	\$
12	1	776990-01 SCB-100 Shielded Connector Block: I/O signal termination accessory for 100-pin MIO bds. Order SH100100 shielded cable separately.	319.00	10%	287.10	287.10	\$
13	1	185095-02 CABLE ASSY, Type SH100-100-FLEX, 2 m	189.00	10%	170.10	170.10	\$
14	1	763444-01 SMA 100, SMA Male to SMA Male Flexible Cable, 38.1cm	81.00	10%	72.90	72.90	\$
						81307.00	\$
						76334.58	CHF

I/Qs

Pos.	Qty.	Part Number and Description	Price	Discount	Unit Price	Amount	Currency
1	1	Complete I/Q demodulator crate 8 channels	25000.00	-	25000.00	25000.00	CHF
						25000.00	CHF

RF source

Pos.	Qty.	Part Number and Description	Price	Discount	Unit Price	Amount	Currency
1	1	Anritsu MG37022A	36227.00	10%	32604.30	32604.30	CHF
2	1	rack mount	514.00	10%	462.60	462.60	CHF
						33066.90	CHF

Driver

Pos.	Qty.	Part Number and Description	Price	Discount	Unit Price	Amount	Currency
1	1	CERN made 12GHz driver amplifier	5000.00	-	5000.00	5000.00	CHF
						5000.00	CHF

An. Ph. Shifter

Pos.	Qty.	Part Number and Description	Price	Discount	Unit Price	Amount	Currency
1	1	Fast analog phase shifter, RL2319.01-12	2700.00	-	2700.00	2700.00	CHF
						2700.00	CHF

OASIS PC

Pos.	Qty.	Part Number and Description	Price	Discount	Unit Price	Amount	Currency
1	1	4U Kontron KISS crate	1700.00	-	1700.00	1700.00	CHF
2	1	CTRI	500.00	-	500.00	500.00	CHF
3	8	U1071ATM3 ACQIRIS Preconfigured 8-bit digitizer 250 MHz, 30 ohm/1 Mohm, 1-2 GS/s 32-64 MS acquisition memory	8600.00	-	8600.00	68800.00	CHF
						71000.00	CHF

VME

Pos.	Qty.	Part Number and Description	Price	Discount	Unit Price	Amount	Currency
1	1	ELMA 9U - VME64x	2900.00	-	2900.00	2900.00	CHF
2	1	CTRP	500.00	-	500.00	500.00	CHF
3	1	CLOCK DISTRIBUTION	630.00	-	630.00	630.00	CHF
4	1	Men-A20	2200.00	-	2200.00	2200.00	CHF
5	1	CONV-DIST	750	-	750	750.00	CHF
6	1	CVORG	1350	-	1350	1350.00	CHF
7	2	SIS3320	6480.00	-	6480.00	12960.00	CHF
						21490.00	CHF

PLC

Pos.	Qty.	Part Number and Description	Price	Discount	Unit Price	Amount	Currency
1	1	CPU + Ethernet + PB + I/Os + Screen	9000.00	-	9000.00	9000.00	CHF
						9000.00	CHF

RF source

Pos.	Qty.	Part Number and Description	Price	Discount	Unit Price	Amount	Currency
1	1	Anritsu MG37022A	36227.00	10%	32604.30	32604.30	CHF
2	1	rack mount	514.00	10%	462.60	462.60	CHF
						33066.90	CHF

Driver

Pos.	Qty.	Part Number and Description	Price	Discount	Unit Price	Amount	Currency
1	1	CERN made 12GHz driver amplifier	5000.00	-	5000.00	5000.00	CHF
						5000.00	CHF

An. Ph. Shifter

Pos.	Qty.	Part Number and Description	Price	Discount	Unit Price	Amount	Currency
1	1	Fast analog phase shifter, RL2319.01-12	2700.00	-	2700.00	2700.00	CHF
						2700.00	CHF

I/Qs

Pos.	Qty.	Part Number and Description	Price	Discount	Unit Price	Amount	Currency
1	1	Complete I/Q demodulator crate 8 channels	25000.00	-	25000.00	25000.00	CHF
						25000.00	CHF

TOTAL	
142101.48	CHF

TOTAL	
167256.90	CHF

LLRF proposal #2 cost comparison

NI

Pos.	Qty.	Part Number and Description	Price	Discount	Unit Price	Amount	Currency
1	1	780291-01 PXIe-1075, 18-Slot 3U PXI Express Chassis	6399.00	10%	5759.10	5759.10	\$
2	1	783890-01 Power Cord, AC, U.S., 125VAC, 15A	19.00	10%	17.10	17.10	\$
3	1	782340-04 NI PXIe-8135 Core I7-3610QE 2.3GHz Controller, Win 7 (32-bit)	5549.00	10%	4994.10	4994.10	\$
4	1	860903-02 NI Standard System Assurance Program for PXI	8190.00		8190.00	8190.00	\$
5	1	781263-03 NI PXIe-5673E 6.6 GHz RF Vector Signal Generator w/ 2 GB RAM	29999.00	10%	26999.10	26999.10	\$
6	1	778274-01 NI PXI-4070 6 1/2 Digit FlexDMM (1.8 MS/s Digitizer, 300 V, 1 A)	2059.00	10%	1853.10	1853.10	\$
7	1	777697-01 NI PXI-2503 24 ch Relay Multiplexer and Matrix Switch	1183.00	10%	1064.70	1064.70	\$
8	6	782097-01 NI 5772 (-01) 2-Channel, 1.6 GS/s, 12-Bit, AC-Coupled, No Antialias Filter Digitizer Adapter Module for NI FlexRIO	6499.00	10%	5849.10	35094.60	\$
9	1	778964-01 NI PXI-6315 Industrial 32 Source/Sink DI, 32 Sink DO Bank Isolated Digital I/O Module and NI-DAQ	479.00	10%	431.10	431.10	\$
10	6	781205-01 NI PXIe-7961R NI FlexRIO FPGA Module (Virtex-5 SX30T)	4499.00	10%	4049.10	24294.60	\$
11	1	781216-01 PXIe-5651 3.3 GHz RF SIGNAL GENERATOR AND CW SOURCE	5899.00	10%	5309.10	5309.10	\$
12	1	781287-02 NI 5761 250 MS/s, Digitizer Adapter Module for NI FlexRIO (DC)	5149.00	10%	4634.10	4634.10	\$
13	1	777878-01 TB-2605 Multiplexing terminal block and analog bus plug kit for use with the NI 2501 and the NI 2503 switches for PXI.	215.00	10%	193.50	193.50	\$
14	1	776990-01 SCB-100 Shielded Connector Block. I/O signal termination accessory for 100-pin MIO bds. Order SH100100 shielded cable separately.	319.00	10%	287.10	287.10	\$
15	1	185095-02 CABLE ASSY, Type SH100-100-FLEX, 2 m	189.00	10%	170.10	170.10	\$
16	1	783444-01 SMA 100, SMA Male to SMA Male Flexible Cable, 38.1cm	81.00	10%	72.90	72.90	\$
						119364.30	\$
						112202.442	CHF

Quadruplers

Pos.	Qty.	Part Number and Description	Price	Discount	Unit Price	Amount	Currency
1	2	RST Quad/Ampl mod. AQA-1933	356.00	-	356.00	712.00	\$
						669.28	CHF

Mixers

Pos.	Qty.	Part Number and Description	Price	Discount	Unit Price	Amount	Currency
1	10	Pulsar mixer ML-01-5C	140.00	-	140.00	1400.00	\$
						1316.00	CHF

OASIS PC

Pos.	Qty.	Part Number and Description	Price	Discount	Unit Price	Amount	Currency
1	1	AU Kontron KISS crate	1700.00	-	1700.00	1700.00	CHF
2	1	CTRI	300.00	-	300.00	300.00	CHF
3	8	U1071ATM3 ACQ/RIS Preconfigured 8-bit digitizer 250 MHz, 50 ohm/1 Mohm, 1-2 GS/s 32-64 MS acquisition memory	8600.00	-	8600.00	68800.00	CHF
						71000.00	CHF

VME

Pos.	Qty.	Part Number and Description	Price	Discount	Unit Price	Amount	Currency
1	1	ELMA 9U - VME64x	2900.00	-	2900.00	2900.00	CHF
2	1	CTRP	300.00	-	300.00	300.00	CHF
3	1	CLOCK DISTRIBUTION	630.00	-	630.00	630.00	CHF
4	1	Men-420	2200.00	-	2200.00	2200.00	CHF
5	1	CONV-DIST	750	-	750	750.00	CHF
6	1	CVDRG	1350	-	1350	1350.00	CHF
7	2	SIG3320	6480.00	-	6480.00	12960.00	CHF
						21490.00	CHF

PLC

Pos.	Qty.	Part Number and Description	Price	Discount	Unit Price	Amount	Currency
1	1	CPU + Ethernet + PB + I/Os + Screen	9000.00	-	9000.00	9000.00	CHF
						9000.00	CHF

RF source

Pos.	Qty.	Part Number and Description	Price	Discount	Unit Price	Amount	Currency
1	1	Anritsu MG37022A	36227.00	10%	32604.30	32604.30	CHF
2	1	rack mount	514.00	10%	462.60	462.60	CHF
						33066.90	CHF

Driver

Pos.	Qty.	Part Number and Description	Price	Discount	Unit Price	Amount	Currency
1	1	CERN made 12GHz driver amplifier	3000.00	-	3000.00	3000.00	CHF
						3000.00	CHF

An. Ph. Shifter

Pos.	Qty.	Part Number and Description	Price	Discount	Unit Price	Amount	Currency
1	1	Fast analog phase shifter, RL2319.01-12	2700.00	-	2700.00	2700.00	CHF
						2700.00	CHF

I/Os

Pos.	Qty.	Part Number and Description	Price	Discount	Unit Price	Amount	Currency
1	1	Complete I/O demodulator crate 8 channels	25000.00	-	25000.00	25000.00	CHF
						25000.00	CHF

TOTAL
114187.72 CHF

TOTAL
167256.90 CHF