

# Laser Alignment System

## for LumiCal and BeamCal

Arkadiusz Moszczyński, Wojciech Wierba, Leszek Zawiejski  
Institute of Nuclear Physics PAN, Cracow

# ILD : International Large Detector

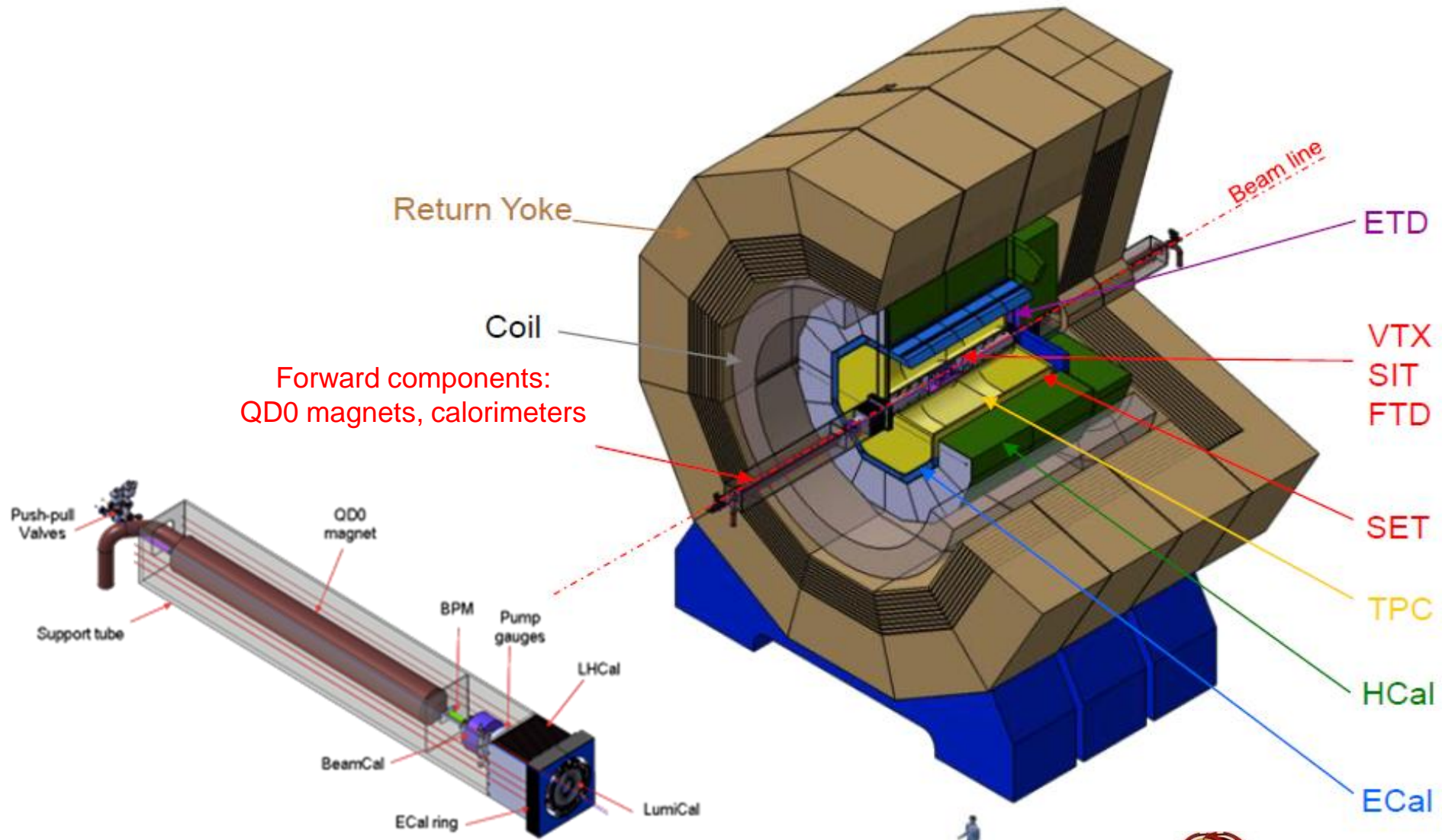

High precision measurements of the physical variables required alignment system (s) for components of ILD, including LumiCal



# LumiCal alignment

High accuracy in luminosity measurements at ILC/CLIC ( $\Delta L/L \sim 10^{-3}/10^{-2}$ ) require precisely measurement of the luminosity detector displacements: less than 500  $\mu\text{m}$  in X,Y directions , 100  $\mu\text{m}$  in Z direction and a few microns for internal silicon sensor layers

## Mechanical aspect of LumiCal alignment

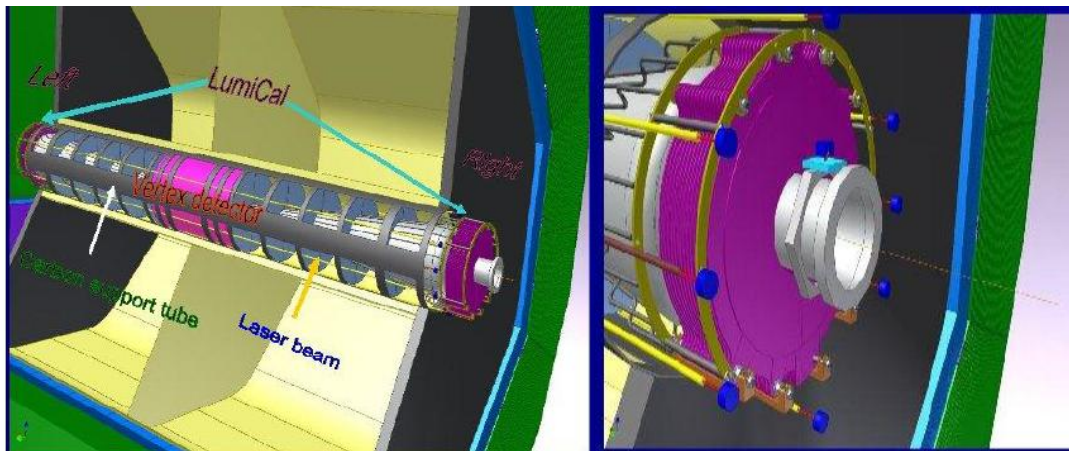

The measurements of absolute distance between Left and Right LumiCal calorimeters

The measurements of the relative distances to QD0 in X,Y and Z directions

Good reference points for position measurement of LumiCal can be:

- QD0 magnet
- Beam Position Monitors
- also beam pipe

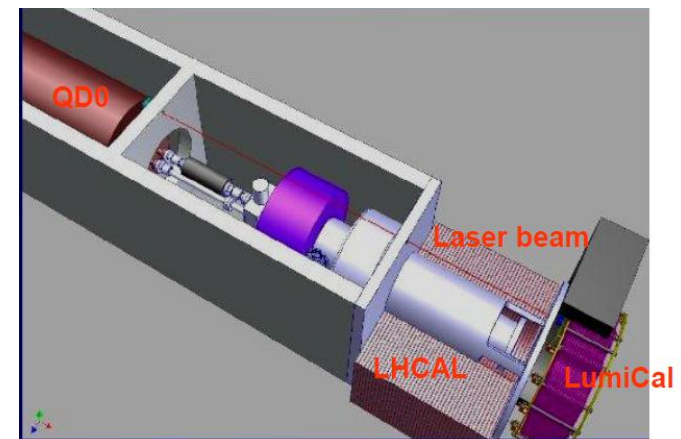

# The design of the LAS system

The laser alignment system will contain the main components:

- infra-red laser beam and semi-transparent position sensitive detectors (PSDs)
- tunable laser(s) working within Frequency Scanning Interferometry (FSI) system

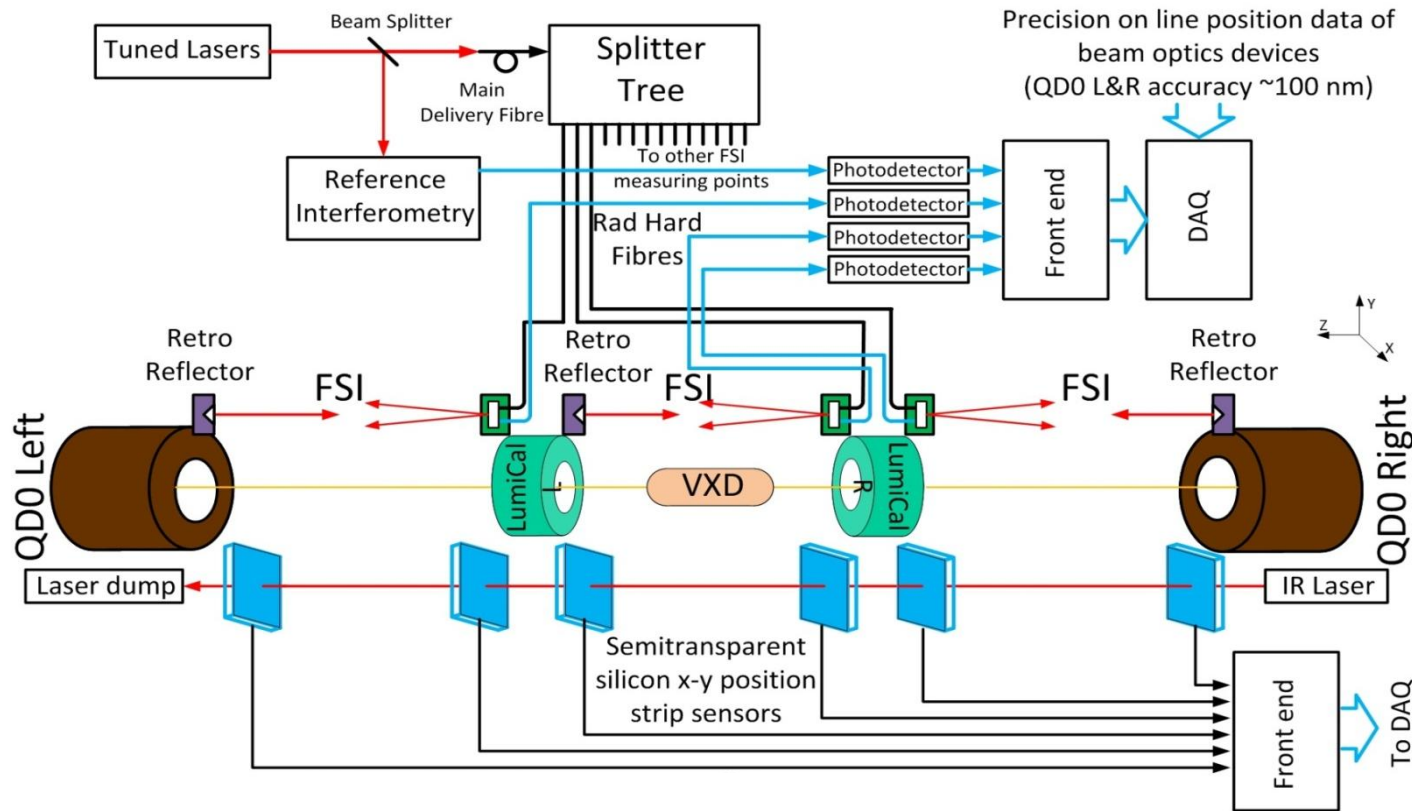

FSI – will be used for measurements of the absolute distance between LumiCal calorimeters by measurement of interferometer optical path differences using tunable lasers (by counting the fringes)

Semi-transparent sensors :  
LumiCal displacements of the internal Si layers and detectors relative positions

A rough estimation of the size of LAS output data is on the level of hundred kB/s and they will be included into LumiCal DAQ system

# Semi-transparent sensors (PSD)



Semi-transparent amorphous silicon strip sensors, DPSD-516 - using laser with wavelength above  $\sim 780$  nm, received from Oxford University,  
 High precision (ZEUS MVD)  
 position measurements in two coordinates X / Y :  $\sim 10 \mu\text{m}$

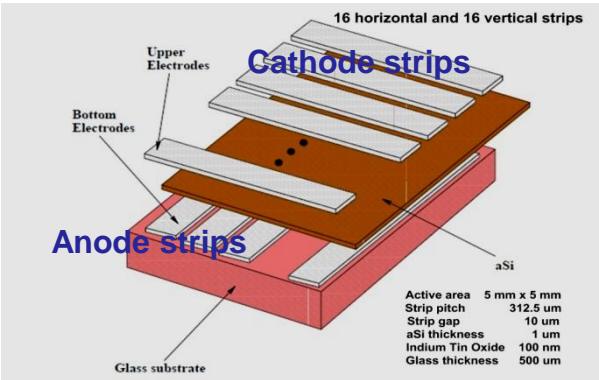

Quality testing of the sensors:  
 microscope, probe station,  
 and laser beam

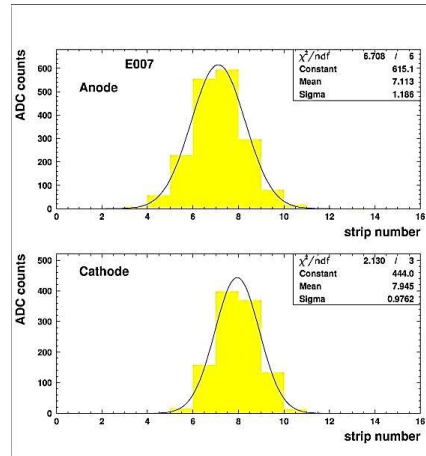
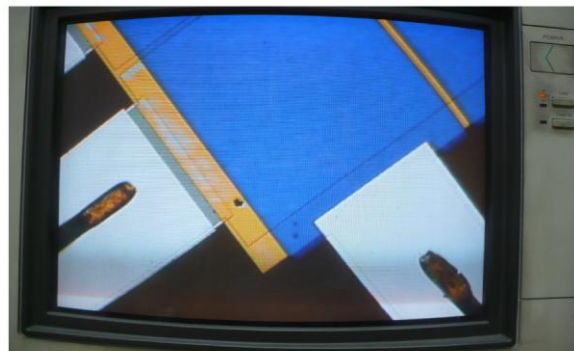

Proper shape of signals distributions from cathode and anode strips

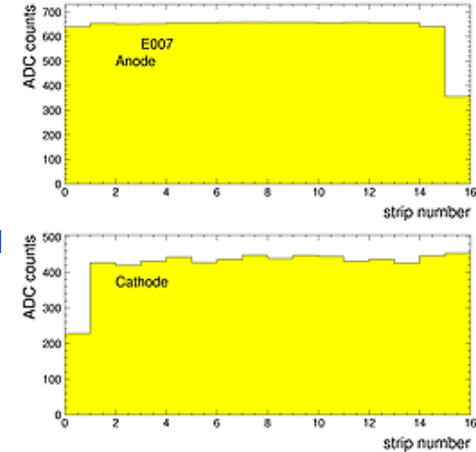

Problem with some of the sensors:  
 no signals from X or Y strips

9 high-quality sensors were selected and they will be used to construct a prototype of the positioning system in laboratory

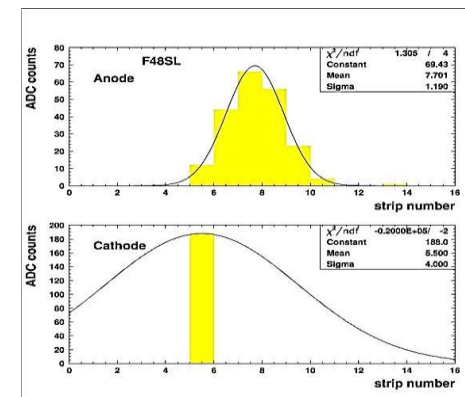

# Towards the laboratory prototype

VME : launch of the system LynxOS  
to read data from sensors

or use a Wiener crate

VM-USB VME controller  
with USB2 interface:  
To read directly data  
from cards and for  
integration with DAQ system

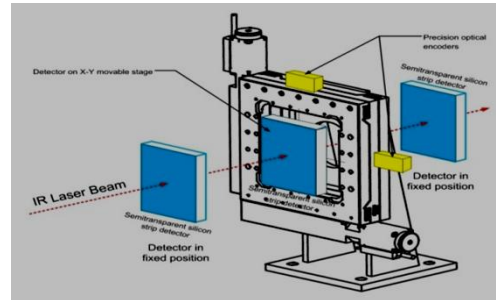
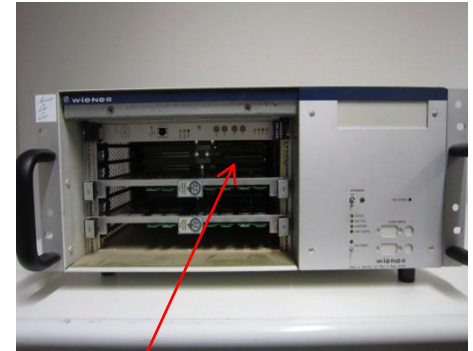
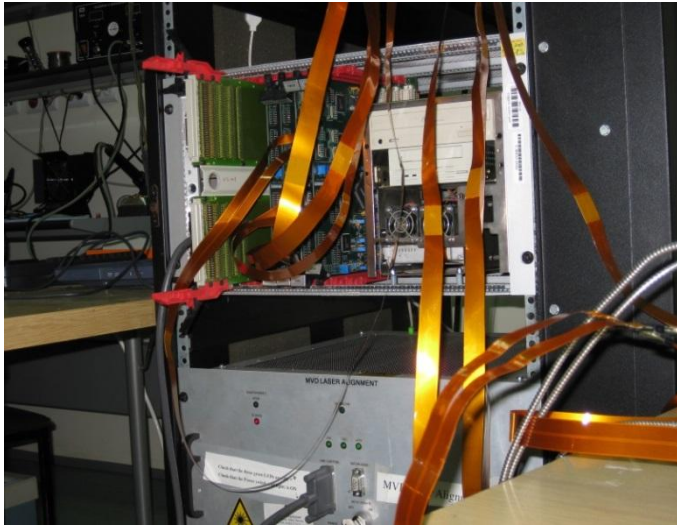

LAB - system prototype with optical movable table 2D  
Studies on the behaviour of the sensors, laser beam and  
calculation of the prototype displacements in ref. frame -  
actual accuracy.

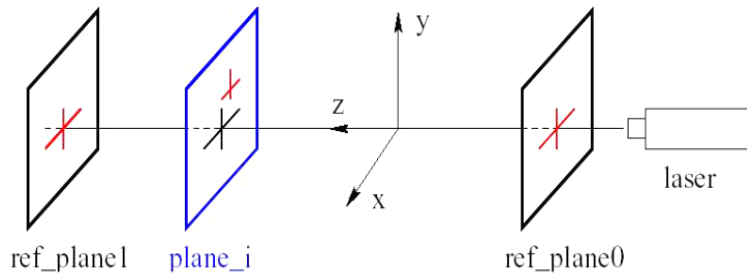

Roughly position calculations –  
mean values:  $m_x, m_y$

$$m_x = \frac{\sum_i x_i w_i}{\sum_i w_i}, \quad m_y = \frac{\sum_i y_i w_i}{\sum_i w_i}$$

with  $w_i = I_i / \sum_i I_i \quad i=1 \dots N$   
 $x_i, y_i$  - strip positions,  
 $I_i$  - strip signals



# Alignment system based on Frequency Scanning Interferometry

FSI technique enables remote, multiple, simultaneous and precise distance measurements. It uses tunable lasers for measurement of interferometer optical path differences and provides absolute distance measurements

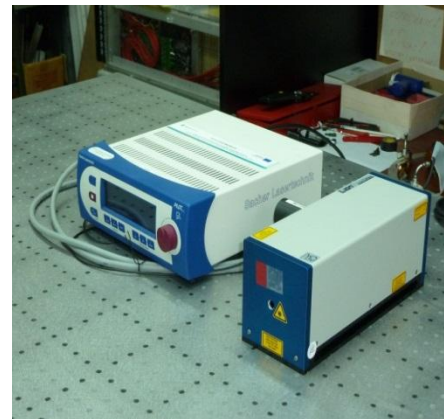

The first step : the tunable laser was purchased to laboratory power 10mW wavelength range: 663 – 678 nm

## Basic principle of Frequency Scanning Interferometry

Ratio of phase change = Ratio of lengths

TUNABLE LASER  
sweep  $\nu$

To interferometer with length  $D$ , to be measured

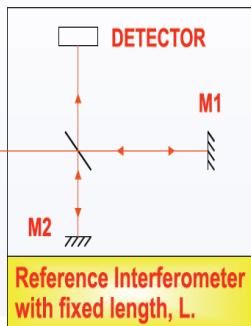

Reference Interferometer with fixed length,  $L$ .

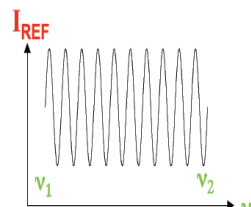
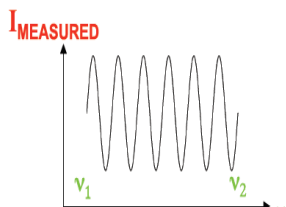

$$\Delta\theta_{GLI} = \frac{2\pi}{c}(D\Delta\nu + \nu\Delta D)$$

$$\Delta\phi_{REF} \approx \frac{2\pi}{c}L\Delta\nu$$

$D$  is unknown length of grid line to be measured

$$\frac{\Delta\theta_{GLI}}{\Delta\phi_{REF}} \approx \frac{D}{L} \text{ if } \Delta D = 0$$

Next step : build in laboratory FSI system prototype (similar to that used for SiD (ATLAS concept))

## FSI with Optical Fibers (initial setup - single laser)

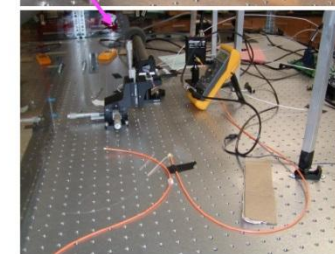
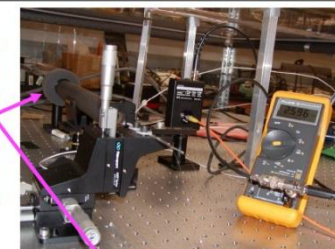
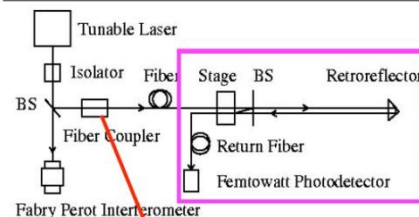

# Summary

- Accuracy of X, Y position measurement using semi-transparent strip sensors can reach  $\sim 10 \mu\text{m}$
- The readout electronics can be placed outside ILD, but long cables decrease accuracy and consume space
- FSI looks very promising – used in many HEP experiments
- Accuracy of very simple FSI absolute distance measurement in air can reach  $\sim 10\text{-}20 \mu\text{m}$  in X, Y and  $\sim 30 \mu\text{m}$  for Z
- More sophisticated FSI methods can give  $\sim 100 \text{ nm}$  (or better) accuracy
- FSI equipment (Tunable Laser -  $\sim 10\text{k}\text{€}$ , Controller  $\sim 5\text{k}\text{€}$ , Optics/FO etc. –  $\sim 100\text{€}/\text{measuring point}$ ) is expensive for low amount of measuring points.
- The FSI laser beam can be splitted up to  $\sim 1000$  measuring points.