

VTRx/VTTx

Status and production plan



Jan Troska

*Stéphane Détraz, Lauri Olanterä, Csaba Soos,
Sarah Storey, Christophe Sigaud, François Vasey*

Versatile Link Overview

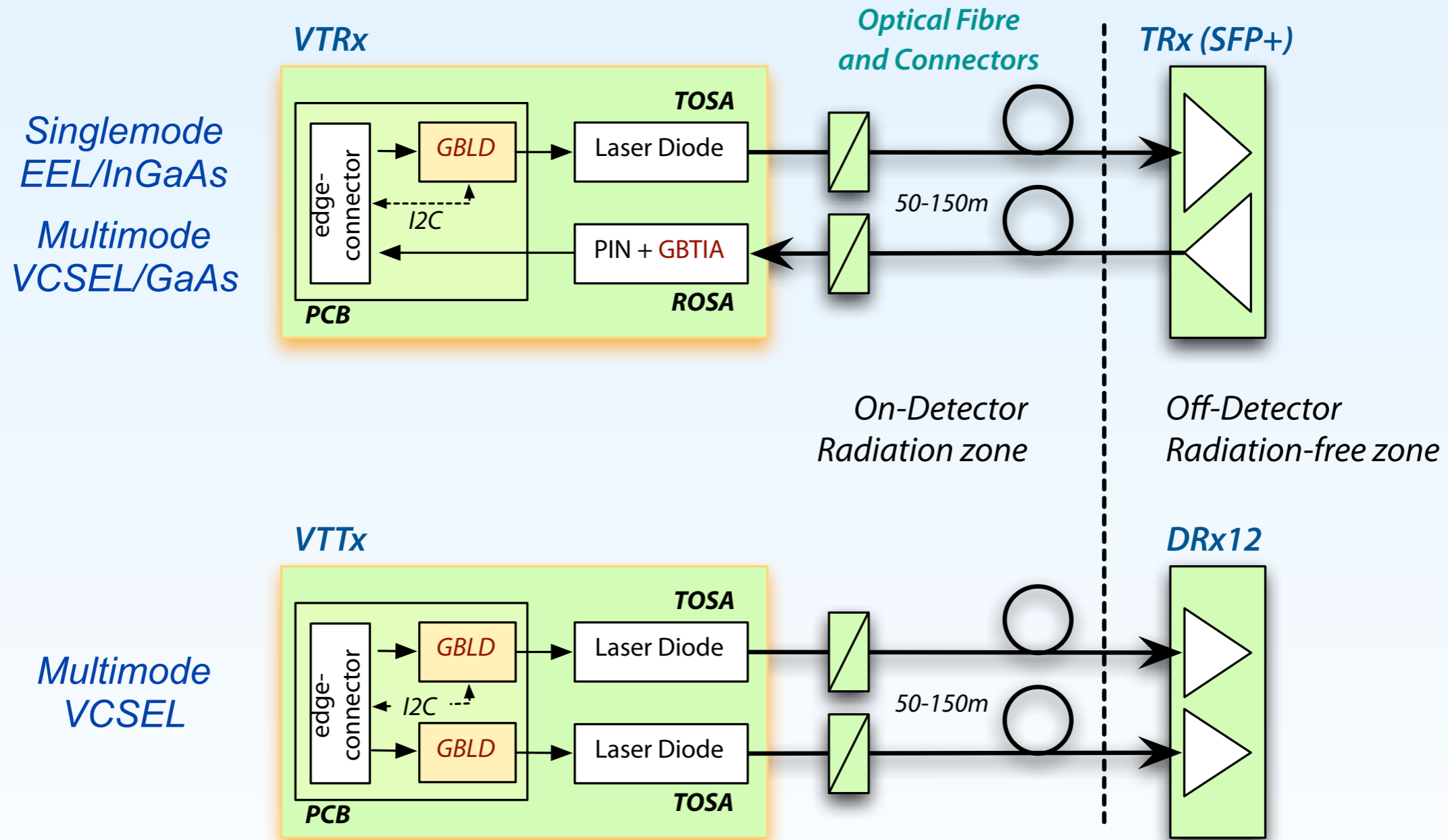

Design Status

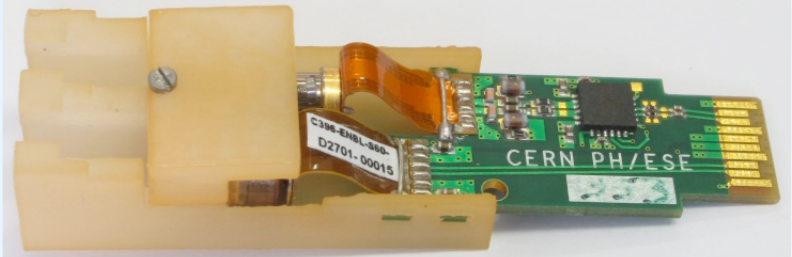
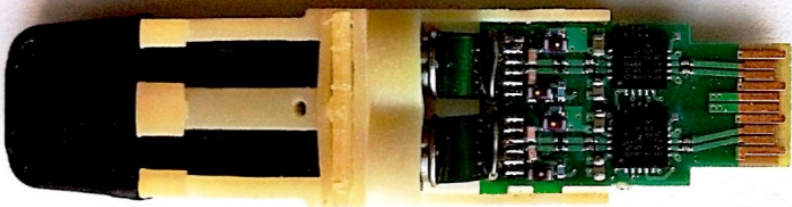
Variant	Laser Driver	TOSA	ROSA	Picture
Single-mode VTRx	GBLD v4.1	Edge Emitter Laser	InGaAs GBTIA v2	
Multi-mode VTRx	GBLD v4.1	850 nm VCSEL	GaAs GBTIA v2	
Multi-mode VTTx	GBLD v4.1	850 nm VCSEL	-	
Rad-soft VTTx	ONET8501V	850 nm VCSEL		

- Performance demonstrated at TWEPP 2012
- Final circuit board layout now complete
- Prototypes available

Comparison to an SFP

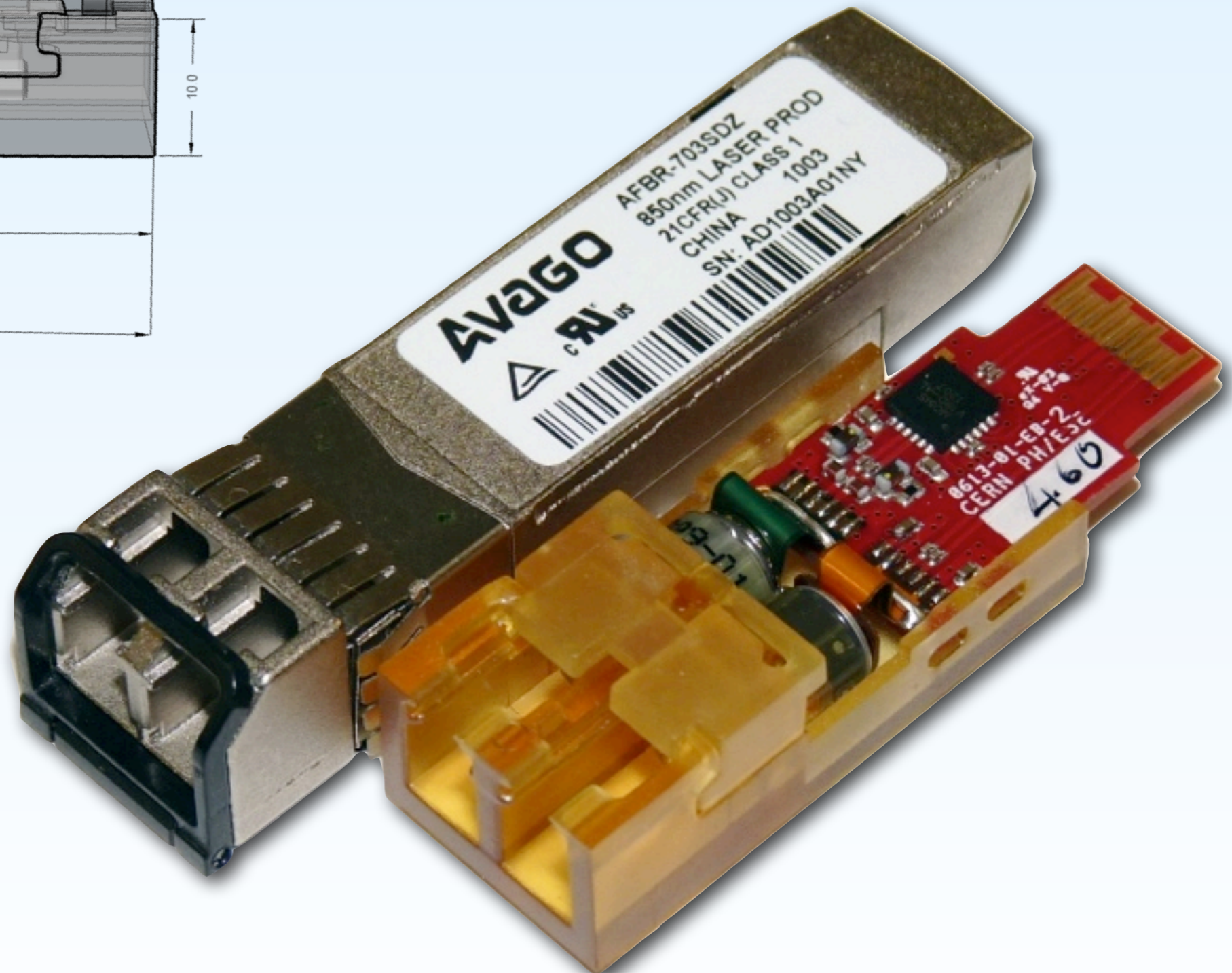
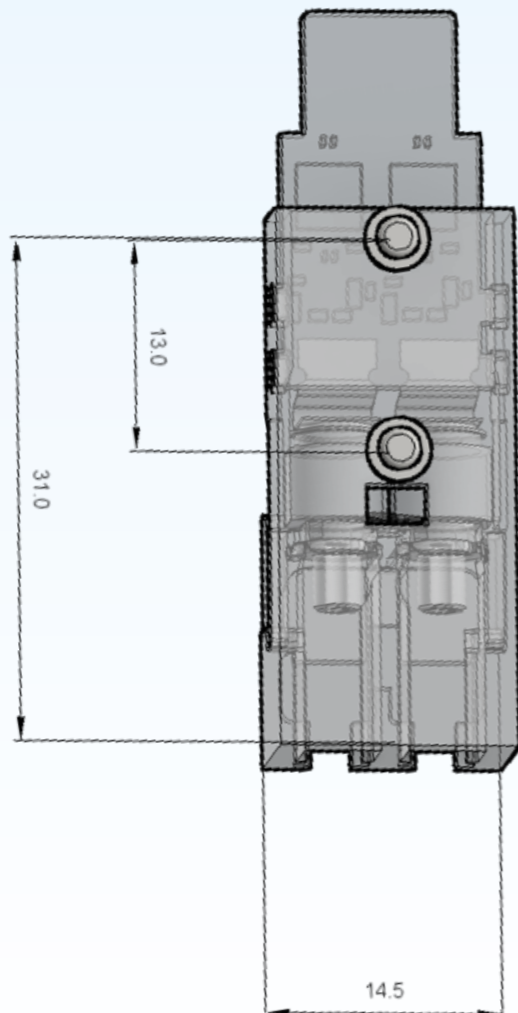
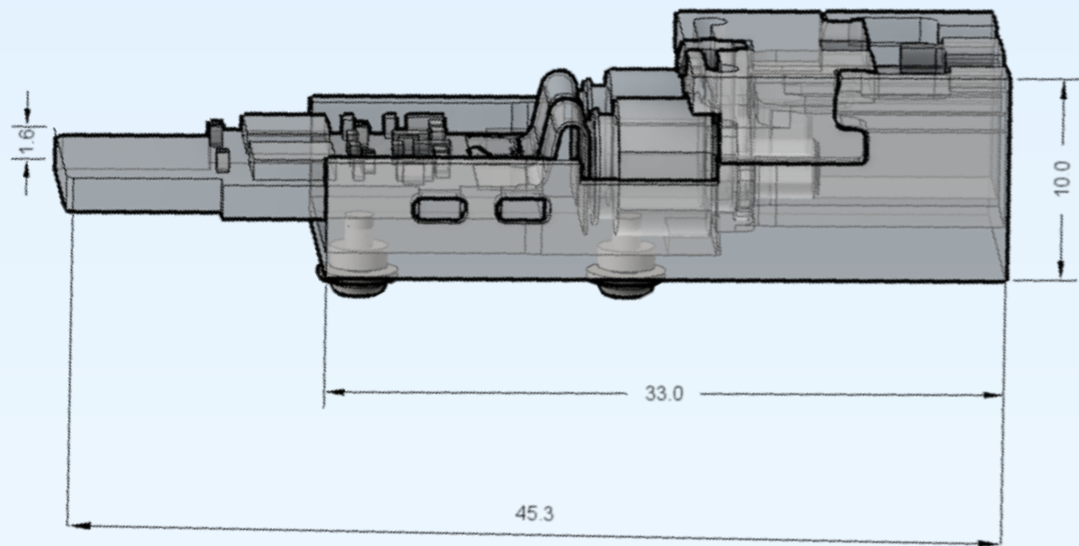

- MM latch design (VTRx & VTTx) complete
- To be produced by injection moulding by PEP Ltd, UK
 - Ultem 1000 material (rad hard)
- First prototypes being evaluated these days
 - Functionality proven
 - Metrology ongoing
- SM latch design being prototyped now
 - CERN rapid prototyping facility
- Production method TBD

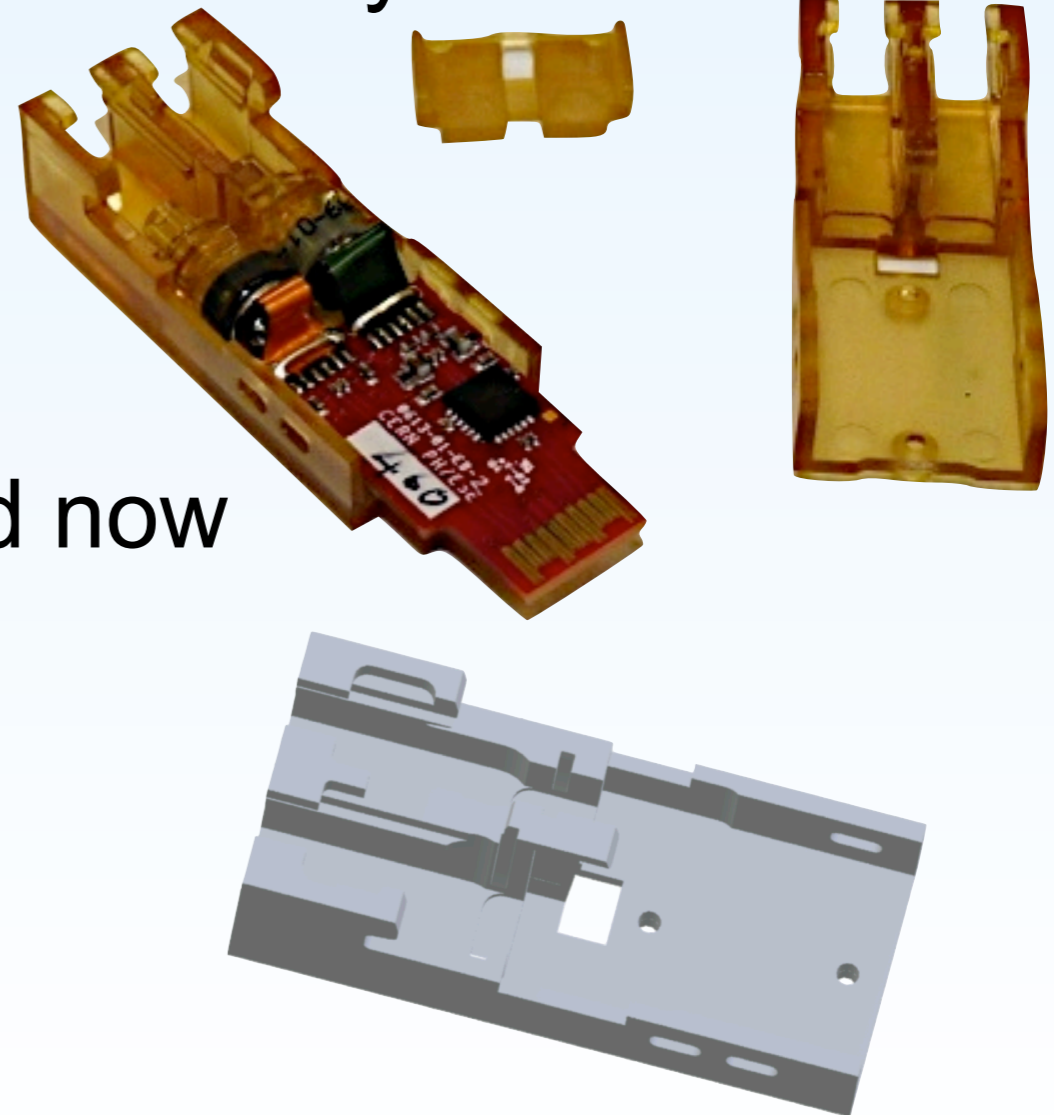

Performance: MM VTRx GBTIA v.2

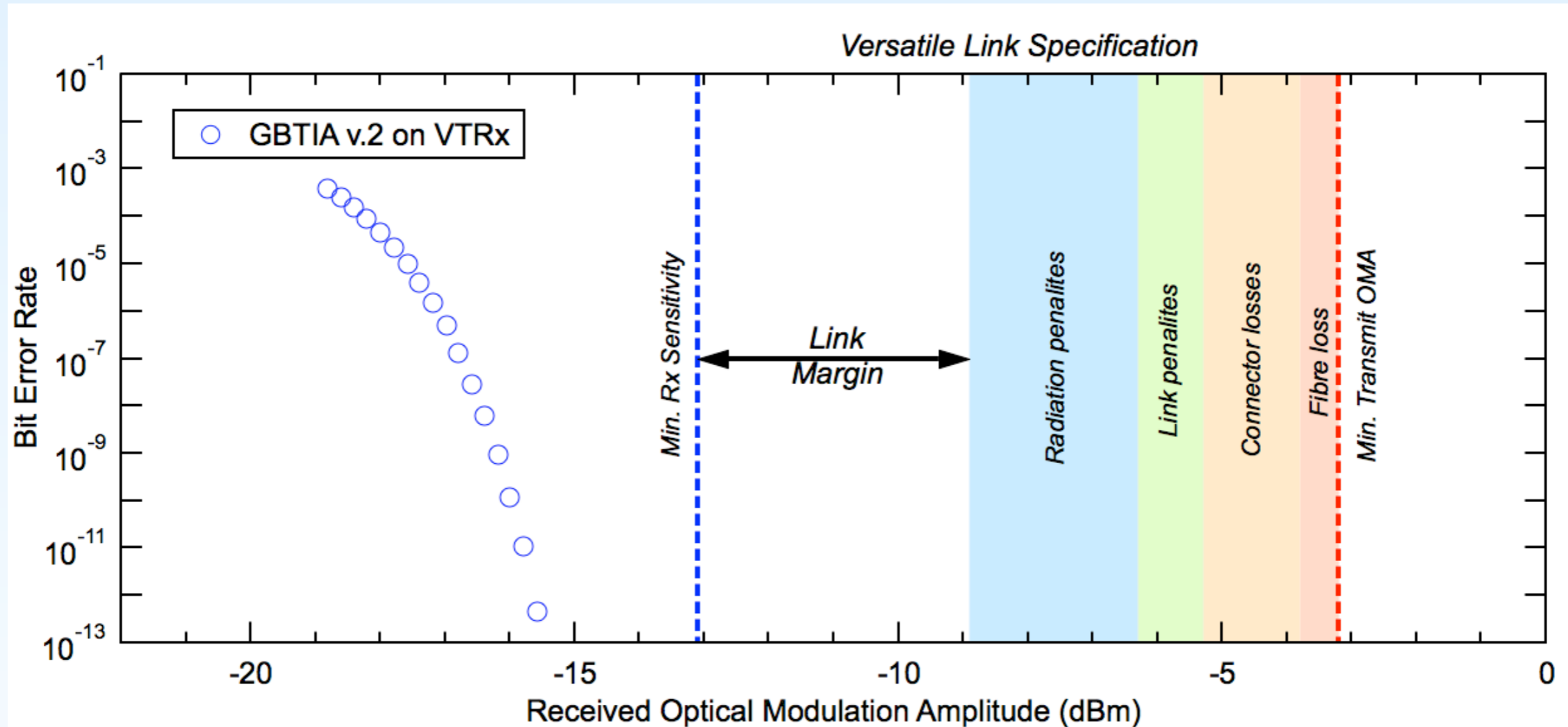

- Very good Rx performance
 - 2nd source identified
- Specifications easily met

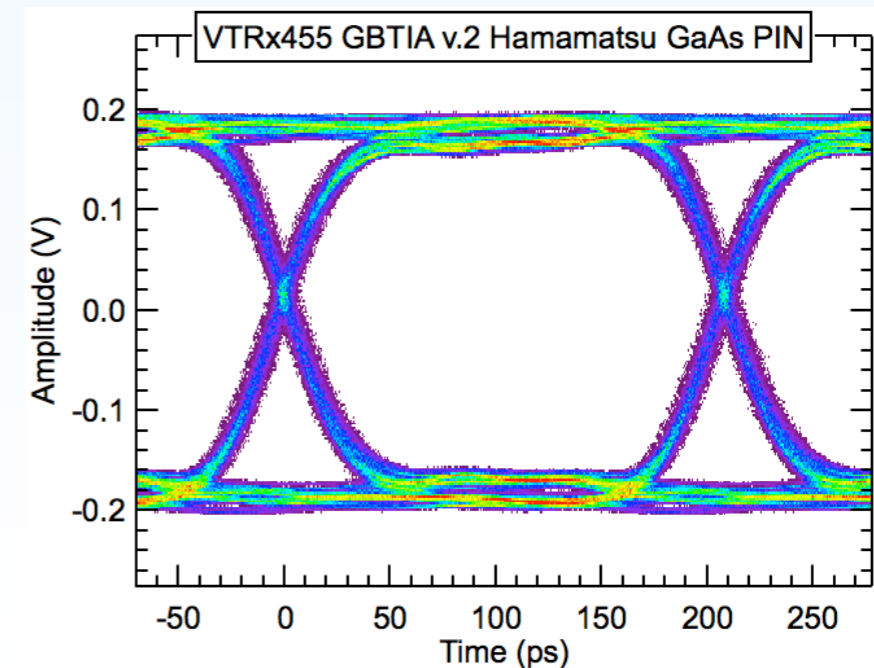

GBLD performance

- Verified performance of GBLD v4.1 to operate over specified operating temperature range.

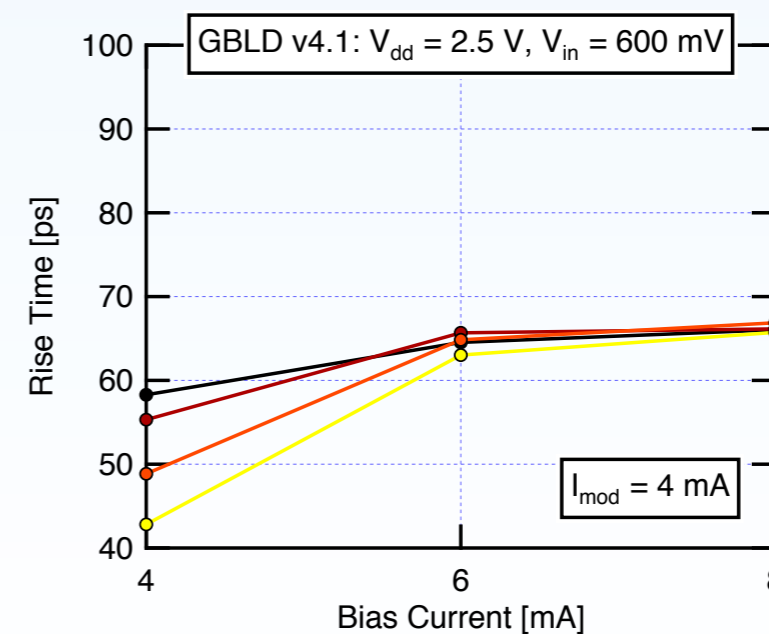
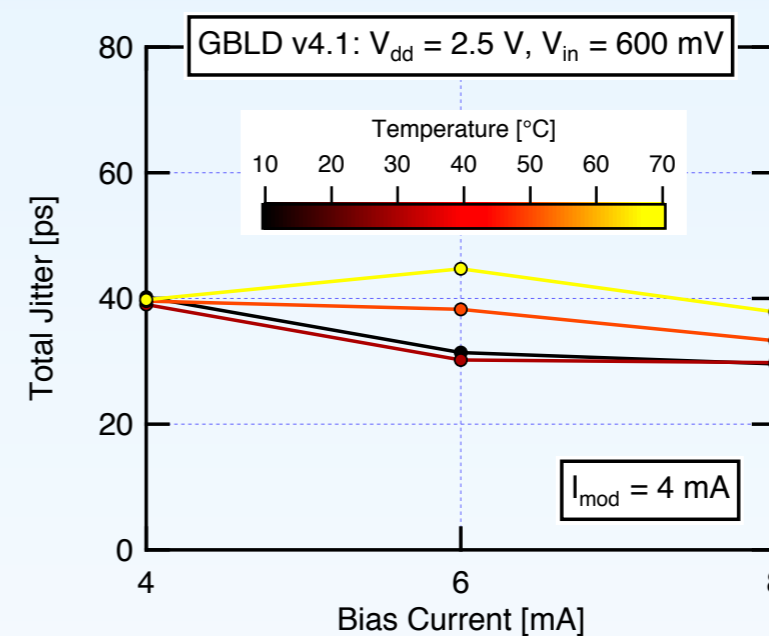
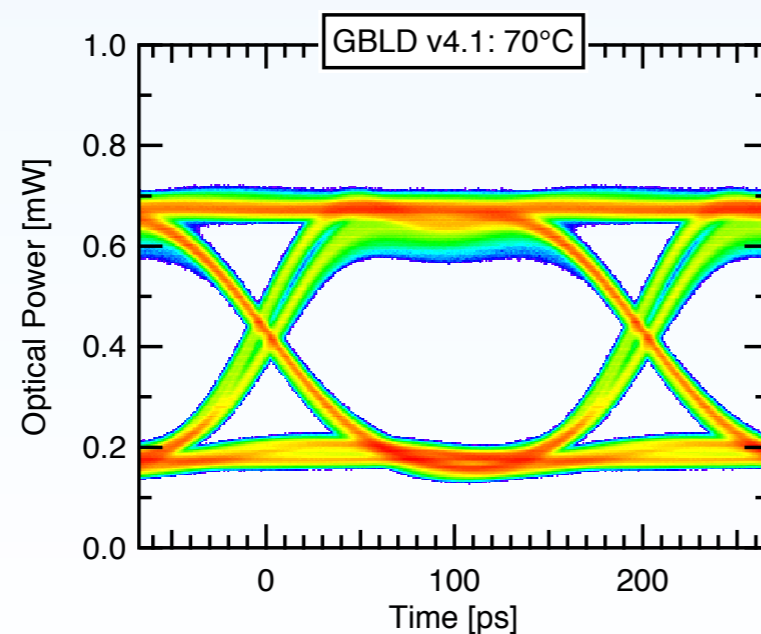
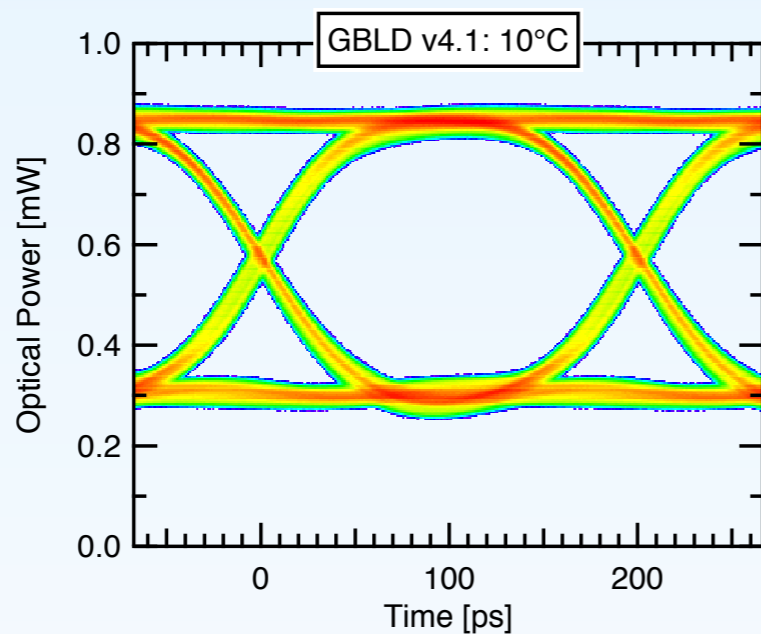

LHCb System-level testing (1)

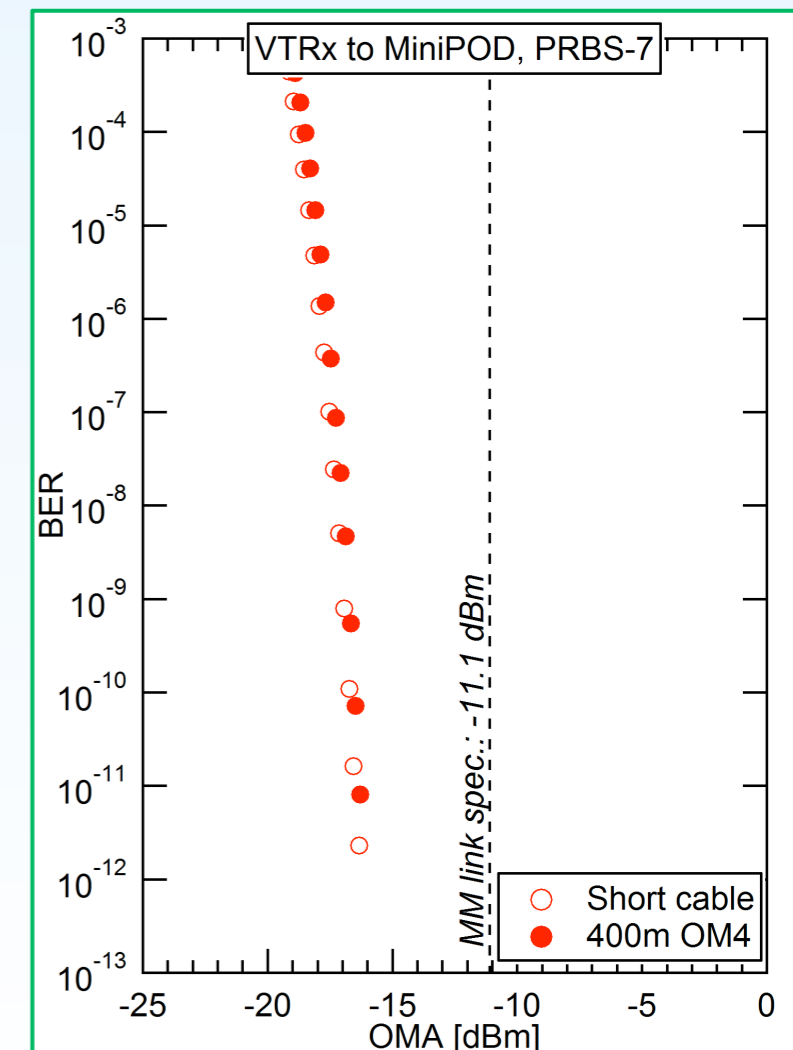
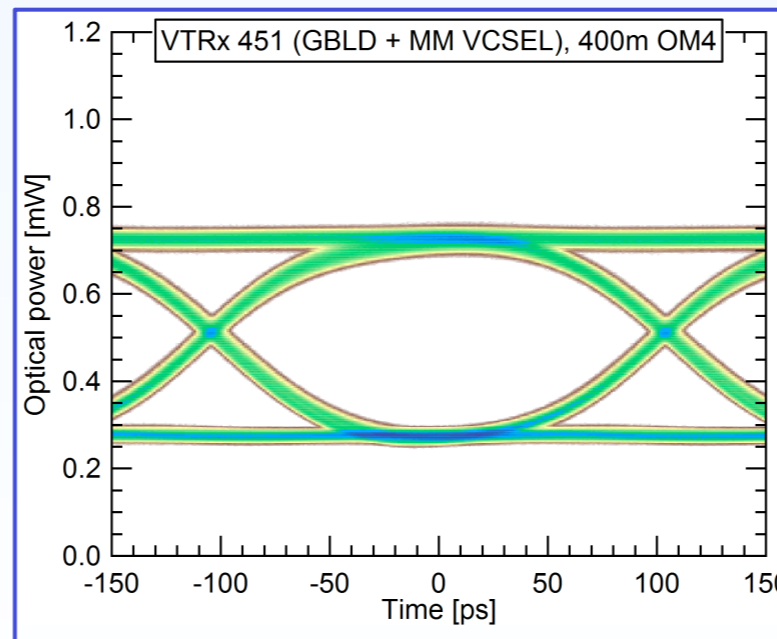
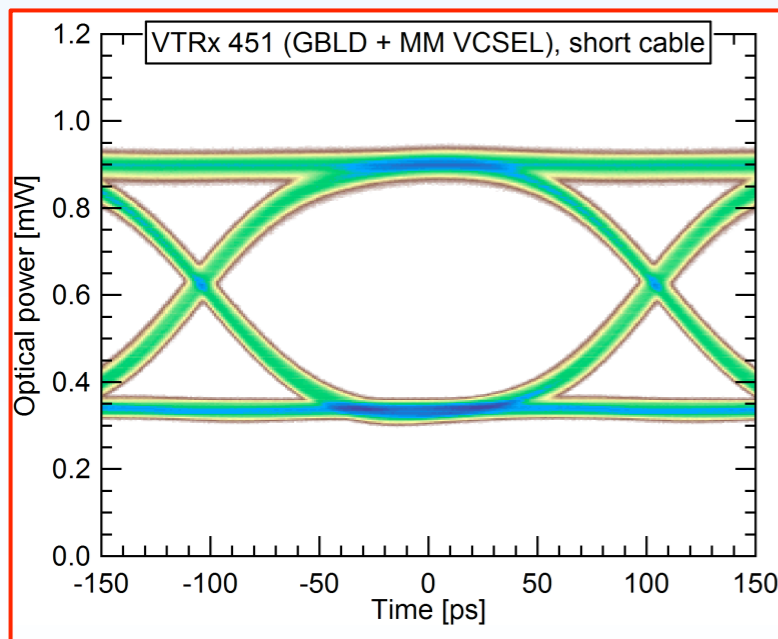
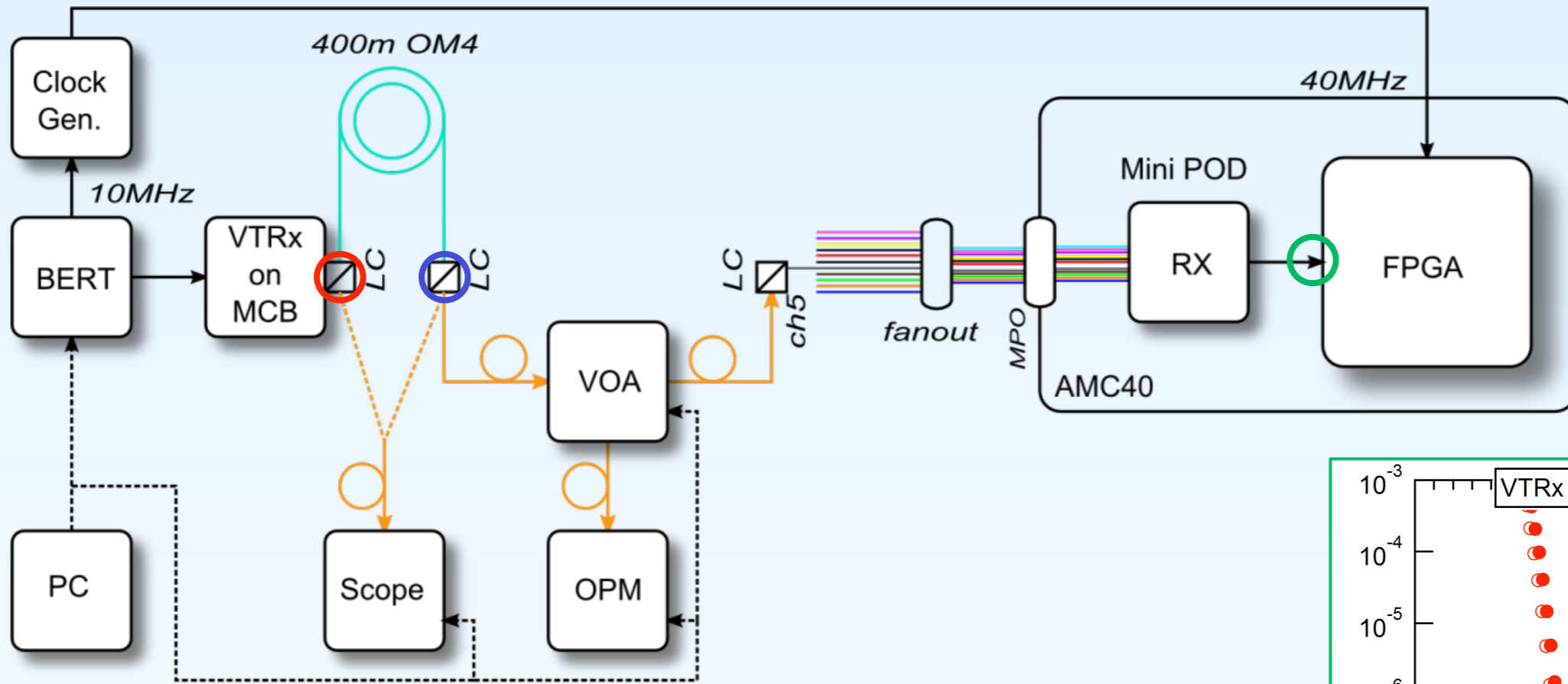

LHCb System-level testing (2)

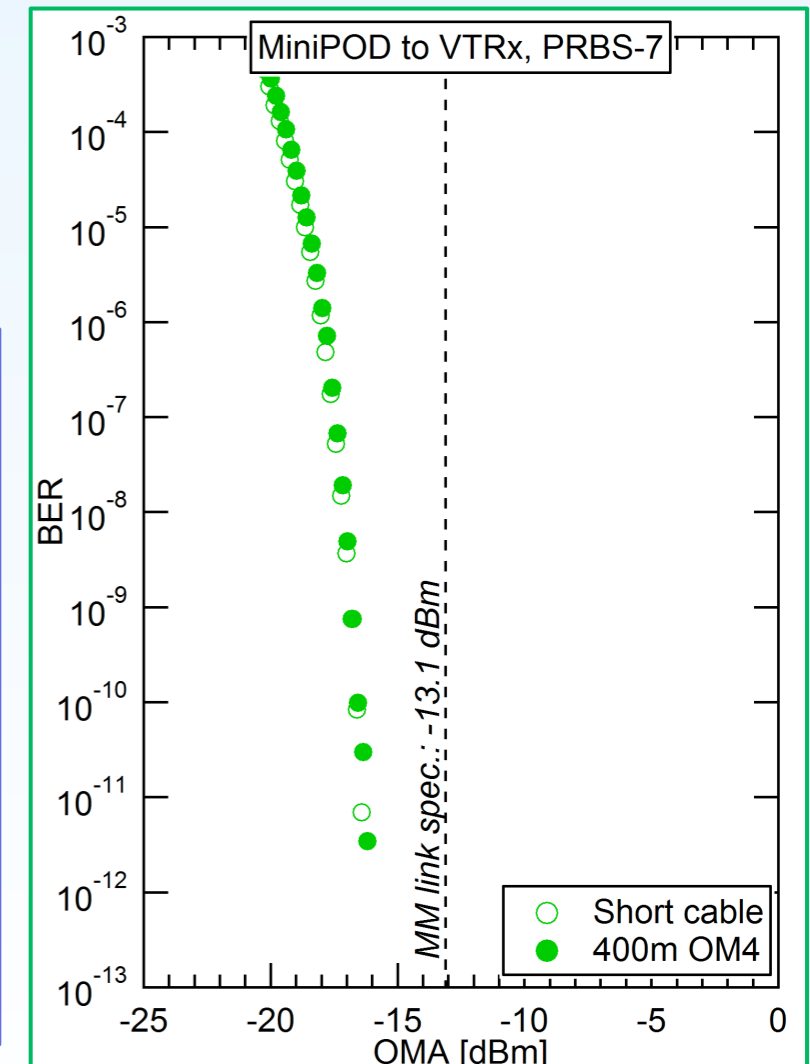
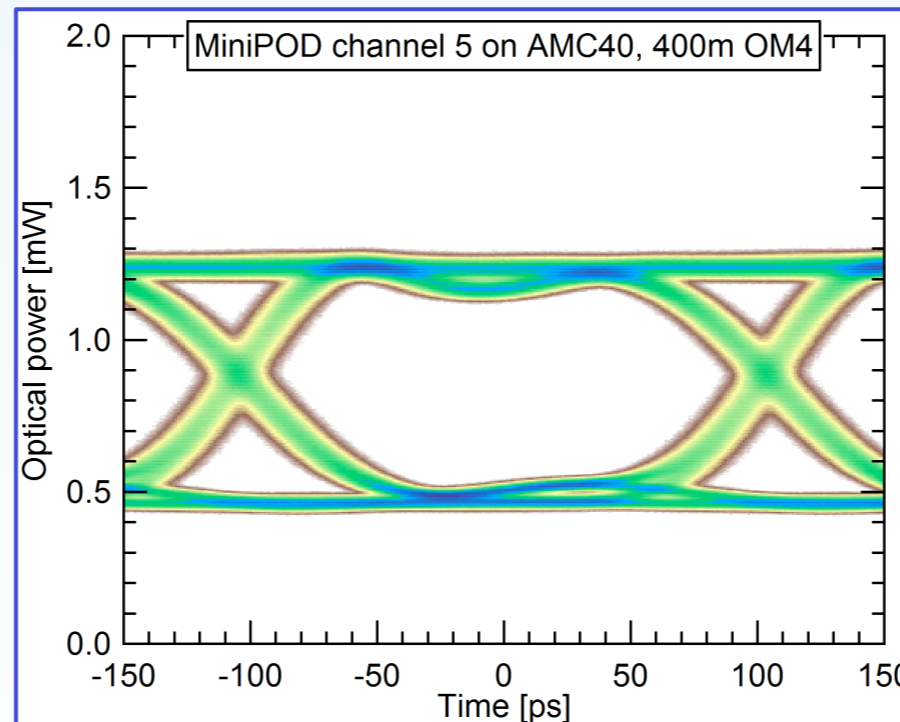
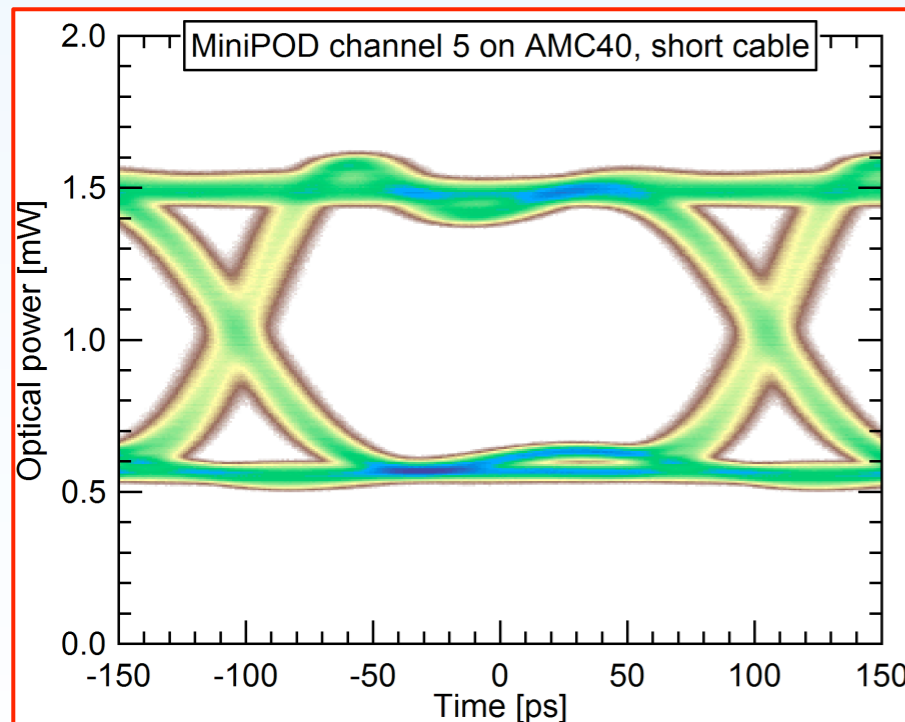
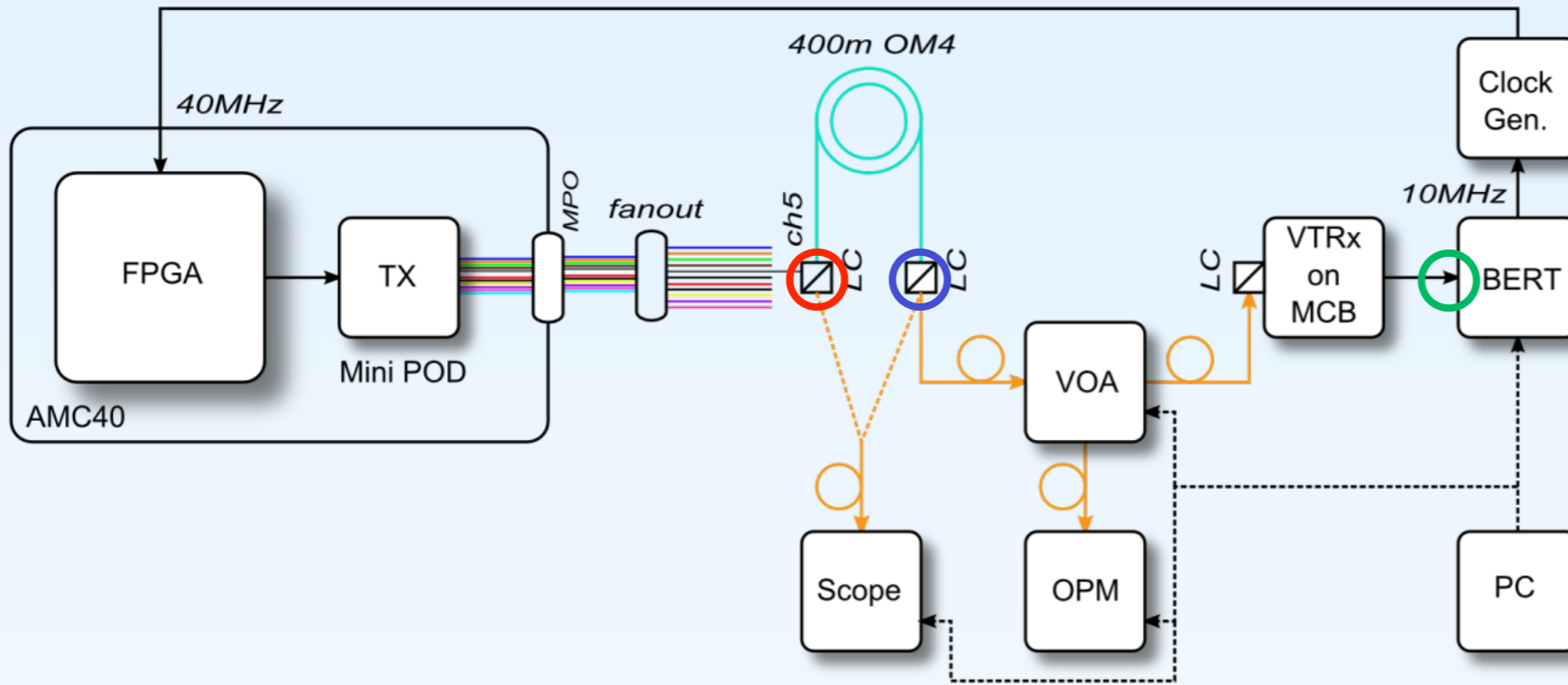

Versatile Link Procurement

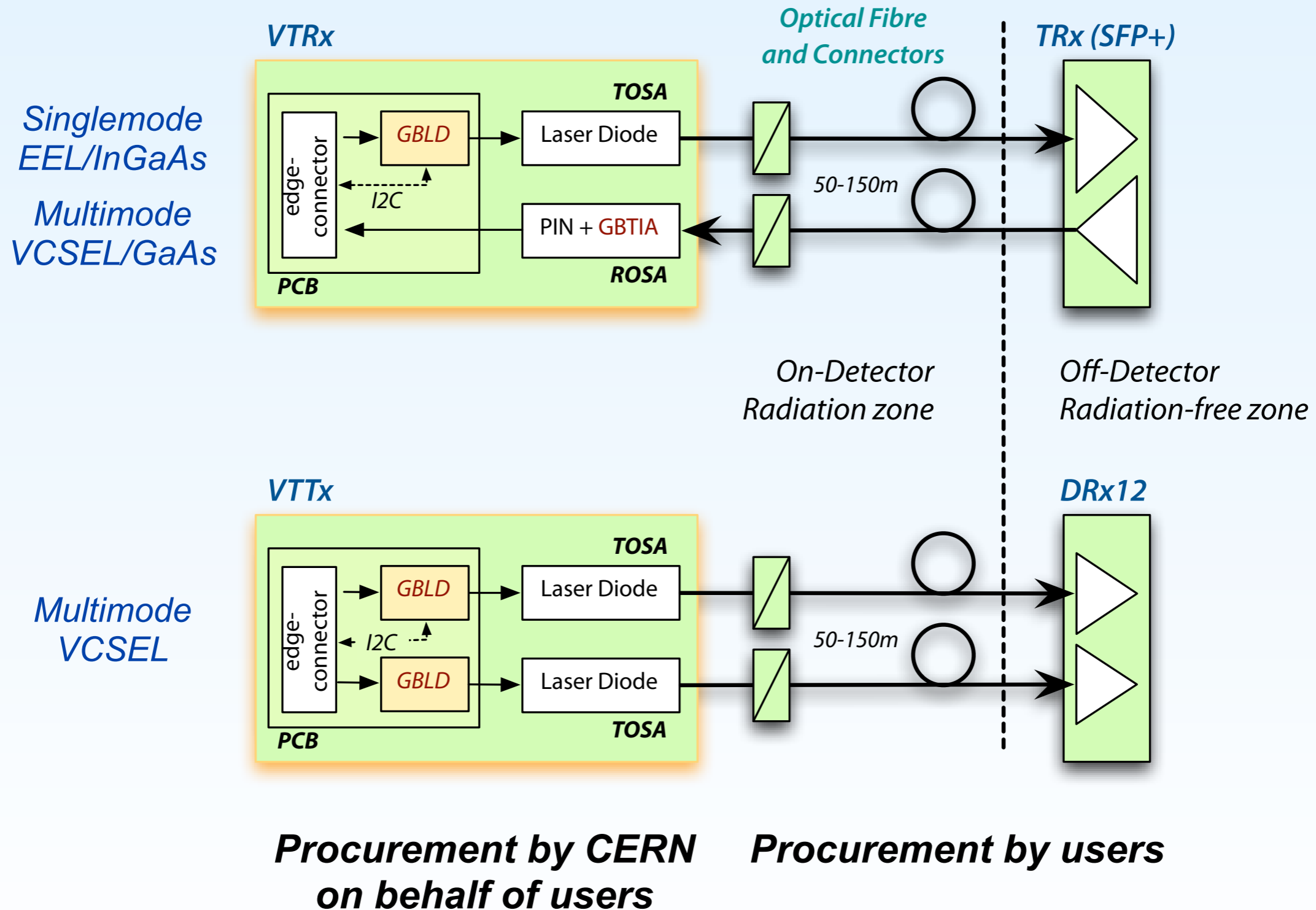

Procurement quantities

Radn Grade & User	TOSA		ROSA		Latch		VTRx		VTTx
	SM	MM	SM	MM	SM	MM	SM	MM	MM
Cal LHCb		16900		2900		9900		2900	7000
Cal HCAL	200	4400	200	400	200	2400	200	400	2000
Tk PIXph1	3000								
Cal ATLAS SmWh		1850		650		1250		650	600
Cal ATLAS LArg		150		150		150		150	
Totals	3200	23300	200	4100	200	13700	200	4100	9600

Complete
MS ongoing
Pre-Prod
Eval.

- Pledges so far
 - ALICE is now also showing interest, likely to represent a large (30-50%) extra number of links
- We procure on your behalf
 - Need funding for parts as well as final modules
 - Need to take funding profiles into account?

- Feasibility of Versatile transmitter and transceiver modules proven
 - Functional and environmental testing
 - Final ASIC versions available and ready for production
- Feasibility to transmit over 400m fibre for data-to-surface application in LHCb proven
- Prototypes are with users
 - CMS HCAL, LHCb
 - More prototypes for distribution are available
- Procurement process defined and started