

Wireless Ultra-Wide-Band Transmission Prototype ASICs for Low-Power Space and Radiation Applications

M. Crepaldi², D. Demarchi², A. Gabrielli¹, P. Motto Ros², G. Villani³

¹INFN-Bologna & Physics and Astronomy Department University of Bologna Italy,

²Dept. of Electronics and IIT@"Politecnico di Torino" Italy,

³STFC, Rutherford Appleton Laboratory UK

Email: alessandro.gabrielli@bo.infn.it URL: <http://www.bo.infn.it/~gabriell>



Abstract

The paper shows the design of microelectronic circuits composed of an oscillator, a modulator, a transmitter and an integrated antenna. Prototype chips were recently fabricated and tested exploiting commercial 130 and 180 nm CMOS technologies. Preliminary results are summarized along with some measurements of the prototypes behavior. In addition, wireless transmission capabilities have been evaluated. The chips fit a large variety of applications like spot radiation monitoring, punctual measurements of radiation in High-Energy Physics experiments or, since they have been characterized as low-power components, readout systems for space applications.

A brief description of the project

The read-out cell is designed to asynchronously trigger an all-digital Ultra-Wide Band (UWB) transmitter operating in a 0-5GHz band, with a repetition frequency dependent on the radiation level. The designed input sensor ranges between 0 and 2V. The floating gate MOS sensor has been recently characterized and here emulated with a commercial radiation-sensitive FETs based on a metal-oxide-silicon p-channel structure, for a 2V variation given an equivalent absorbed dose of 100rad within 1 and 100krad. A maximum sensitivity of 1mV/rad is estimated up to 10krad. The paper shows the design of a preliminary microelectronic circuit that includes a sensor, an oscillator and modulator, which is now under fabrication. The prototype will be interfaced with an external power supply and to an antenna for pulse transmission, to provide a preliminary proof-of-concept validation before a complete integration. Given the small estimated area of the complete chip prototype, comprising the antenna, i.e. less than 1mm², the IC can enable a large variety of applications for spot radiation monitoring systems (High-Energy Physics experiments might benefit of this concept). The paper shows measurements on a mini test-board equipped with the full-custom components comprising an external transmitter IC that will be integrated in the ASIC prototype (TowerJazz). First measurements, obtained at the "Istituto Italiano di Tecnologia", Center for Space Human Robotics, demonstrate the feasibility of the proposed event-driven asynchronous Ultra-Low Power (ULP) UWB transmission. The Science and Technology Facility Council of the Rutherford Appleton Laboratory (RAL), UK, supports the entire research. Figures below show the sensitive cell layout, a block diagram of the design under development plus a picture of the submitted test device.

A previous version of the prototype, without antenna and transmitter, has already been tested and the approach has proved.

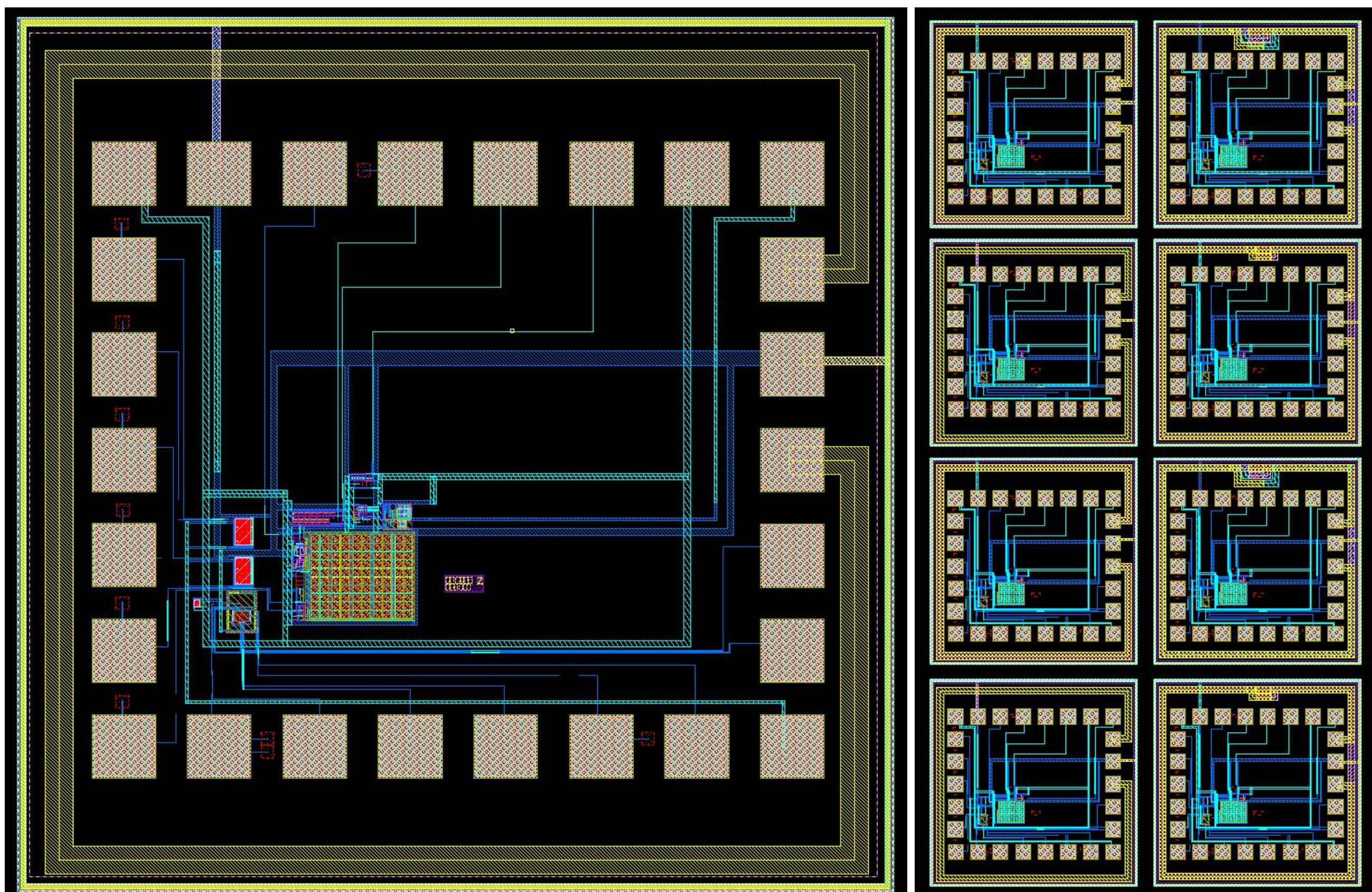

This is the picture of the ASIC, designed with TowerJazz 180nm 4M Technology.

The whole layout dimension is 1 x 1 mm².

The pitch of the pads is: 100 μm.

The antenna is easily visible.

4 types of antennas and 2 types of sensors have been submitted in a combination of 8 different layouts.

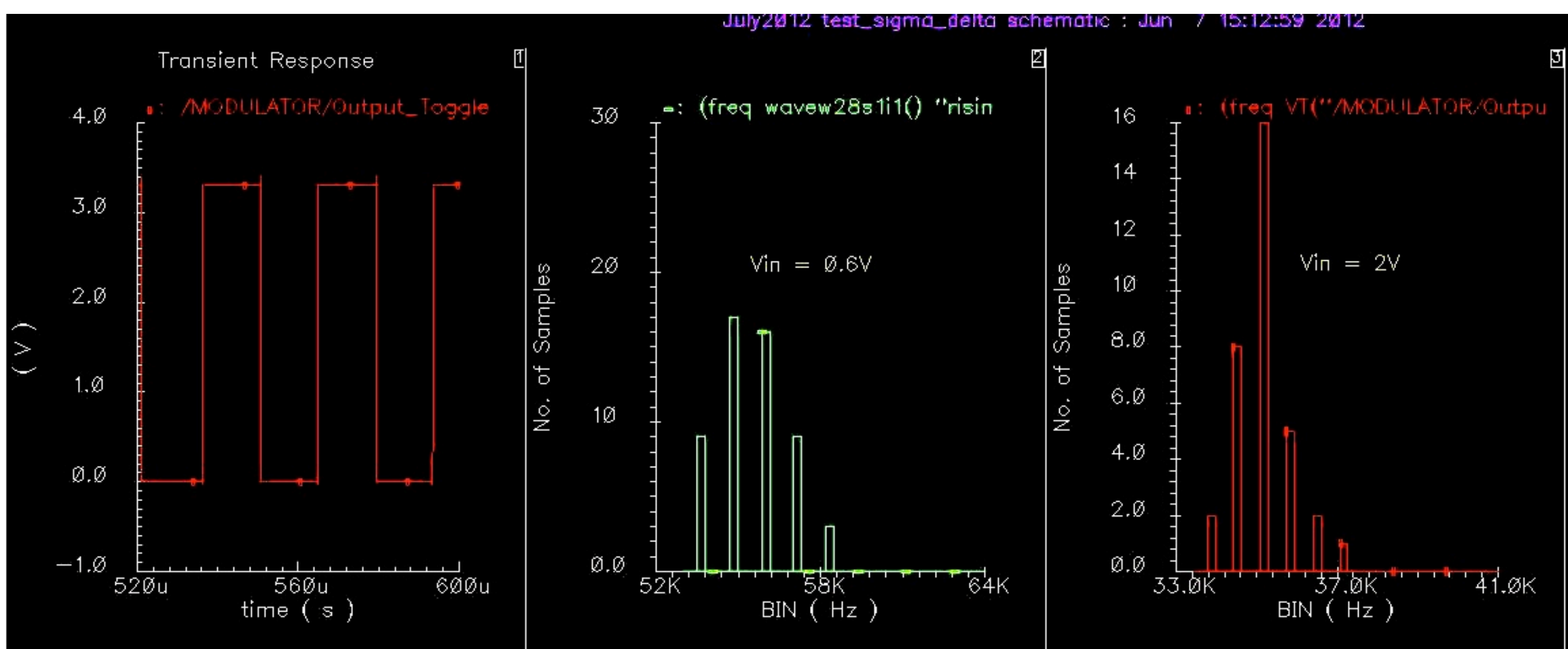

Figure shows the spread of the Toggle frequency while keeping stable the input VIN level. In particular two distributions are shown, for VIN=0V and VIN=2V. It is apparent that the output frequency shifts due to the noise so, in principle, the receiver circuit that will acquire the Toggle signal, will be required to average the signal to filter out the noise and measure the right frequency value.

A simulation has been carried out to estimate the power consumption of the entire circuit and, eventually, the real chip was also tested. The order of magnitude of the total current is around **100 mW @ 3.3V for about 100 ns** while in the rest of the period the total current is hundreds of uW. This leads to an estimation of **some hundreds uW as average power consumption**.

The Sigma-Delta architecture

It is here described the design of a Sigma-Delta-like modulator to interface with the analog output voltage level of a radiation-sensitive CFLASH cell previously designed, and separately tested, using the 180nm SL TowerJazz technology. The aim is to be able to read out the cell's output level, which is expected to shift upon radiation, and convert this voltage variation into a frequency shift over a free-running oscillator. The overall circuit is based on 3.3V MOS transistors only circuit, hence is powered at 3.3V, operating without any inductors and resistors. Figure 1 shows the basic blocks that implement the modulator:

- a Sloper which acts as a free-running oscillator since it integrates a voltage level, being successively reset by the output signal of the adjacent comparator;
- a Comparator which compares the output level of the CFLASH sensor with a predefined reference level, here set at 2V;
- a Toggle which reads out the output saw-tooth signal of the comparator and generates a more stable square waveform with a frequency range of the order of hundreds of kHz. For this purpose a digital frequency divider was also used (FFs);
- an Enable_Transmitter which creates a about 200 ns monostable signal to enable the following Ring_Oscillator;
- a Ring_Oscillator that oscillates at 400 MHz, if enabled. It drives the Transmitter for the final antenna coupling;
- one Transmitter able to drive, at 400 MHz, a load composed of a parallel 10 pF capacitor 50 ohm resistor, while maintaining a voltage swing of about 2V being powered at 3.3V.

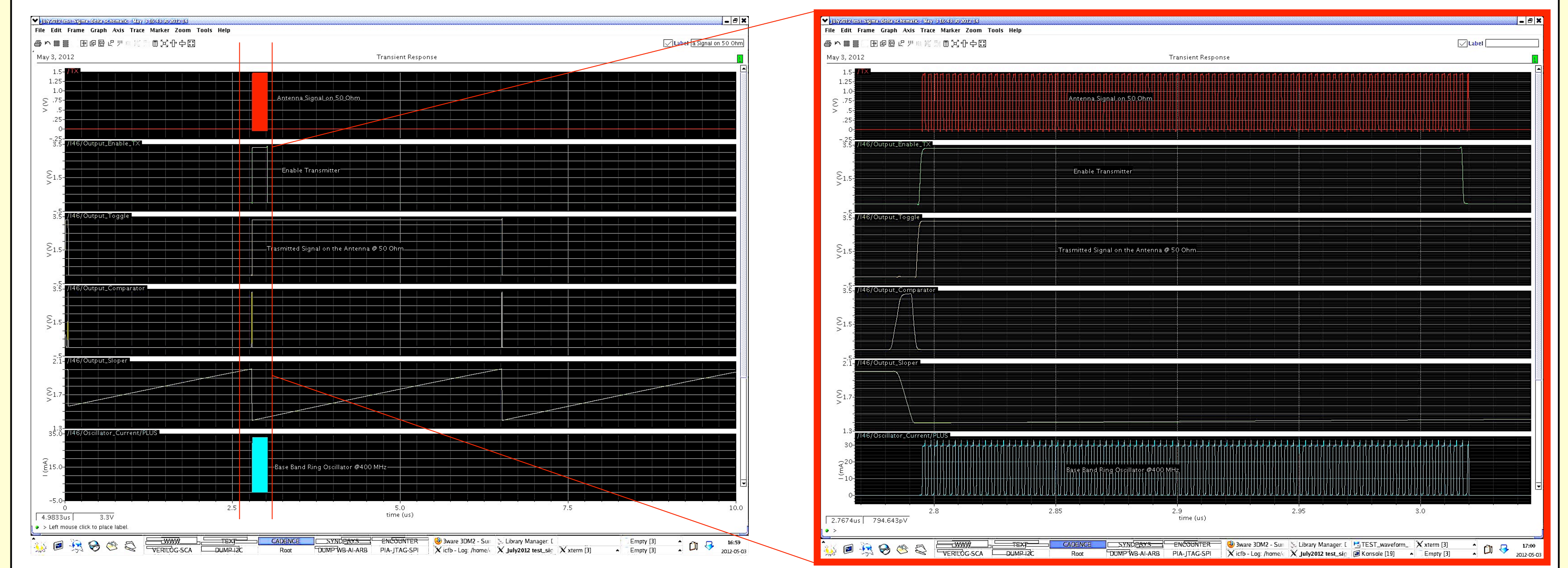
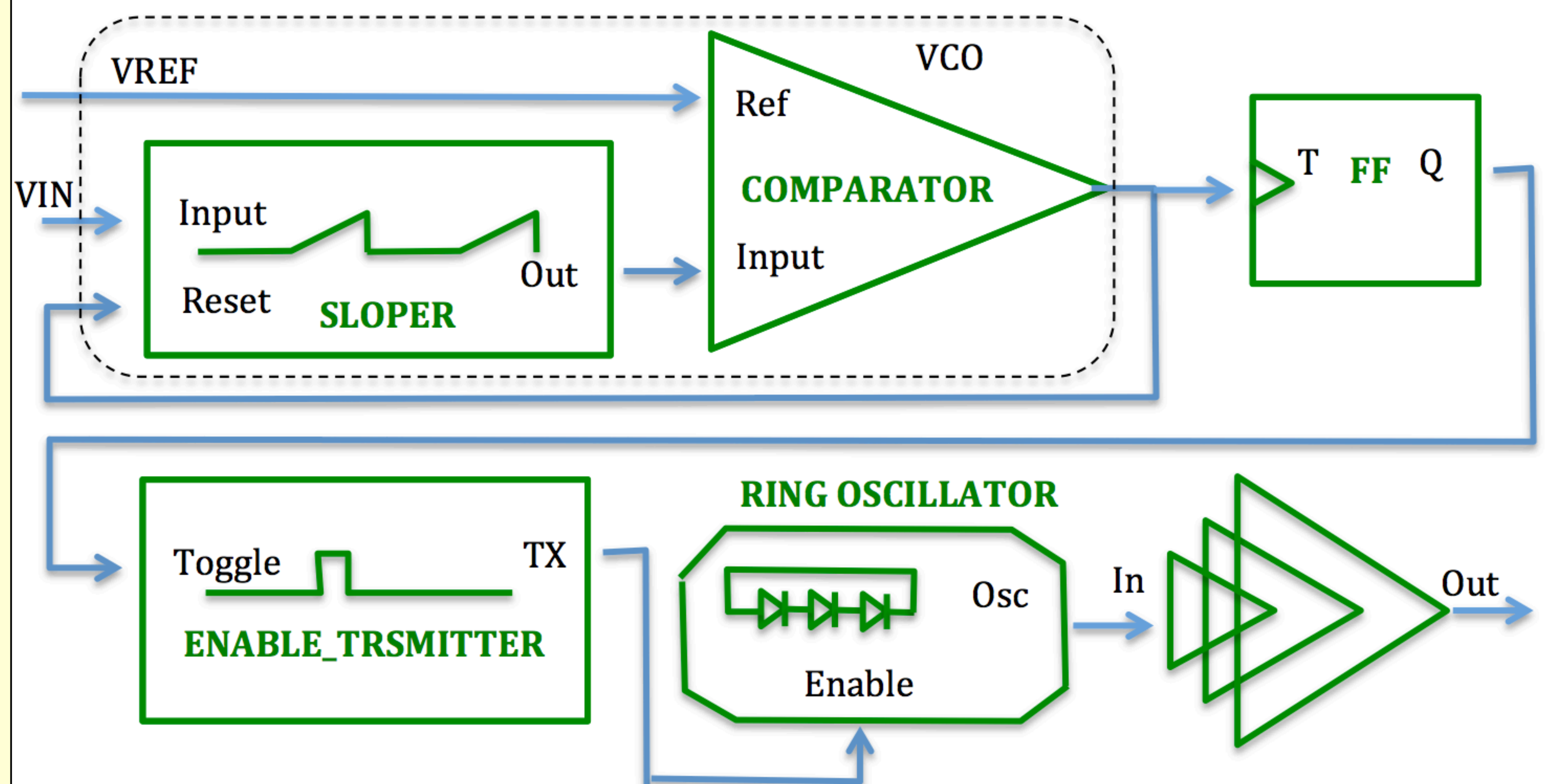

The expected sensitivity

The circuit refers to an input "VIN" voltage from the CFLASH cell whose range may vary from 0 to 3 volts. In addition, also the temperature might change in a real application, for example from 20 to 50 oC. Top left figure shows a simulation by varying the "vin" voltage as the CFLASH cell had measured an impinging radiation.

It is apparent in the Top-Left figure that as "VIN" varies 0 to 3V the Toggle circuit produces a square wave with almost decreasing frequency from about 85 to 50 kHz.

Top-Right figure shows the detected power vs distance. The two bottom figures show the UWB spectrum of the transmitted signal and the correspondent time plot of the received and amplified RF wave.

As possible estimation of the sensitivity of the device is apparent that 2 volts of input variation decrease the free running frequency of the Toggle circuit of about 10 kHz/V or 10 Hz/mV variation.

