



# SOLUTIONS

Machines et prestations par rayons X

## X-Ray non destructive testing (Digital Radioscopy and 3D CT Scan)



- Services :
  - Digital radiology
  - Computed Tomography Scan (CT-scan)

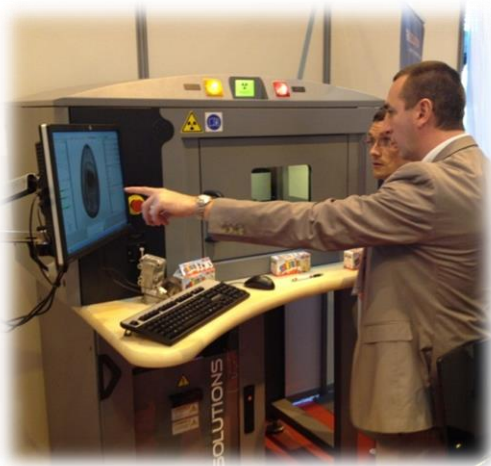

- X-Ray Equipment
- Software development



## I. X-Ray Equipments : from standard to customized

DeskTom	EasyTom 3	EasyTom 4
		
<p>Inside volume : 500x500x500            Max scanning zone : <math>\varnothing 200 \times 250</math> mm            Sample weight : &lt; 5kg</p>	<p>Inside volume : 700x450x550            Max scanning zone : <math>\varnothing 300 \times 500</math>            Sample weight : &gt; 20 kg</p>	<p>Depending on configuration</p>

## II. Digital radiography : principle

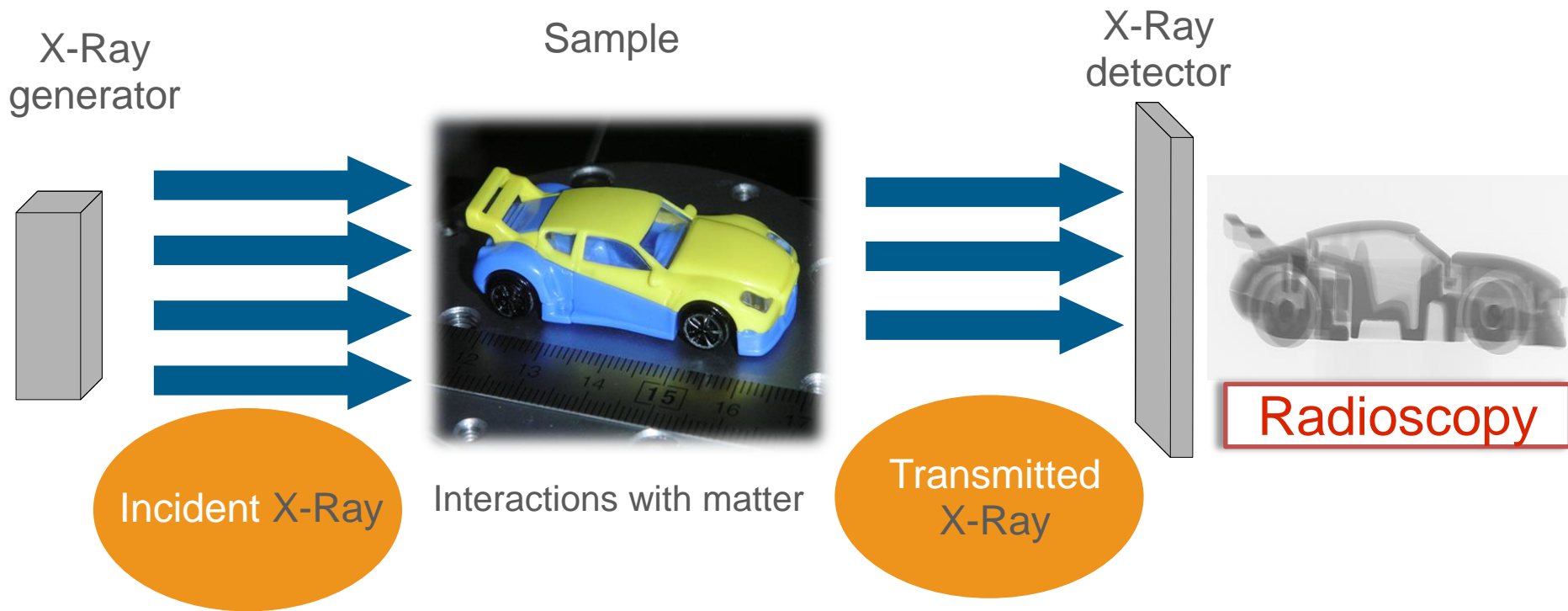

### Voids detection



### Real-time radioscopy

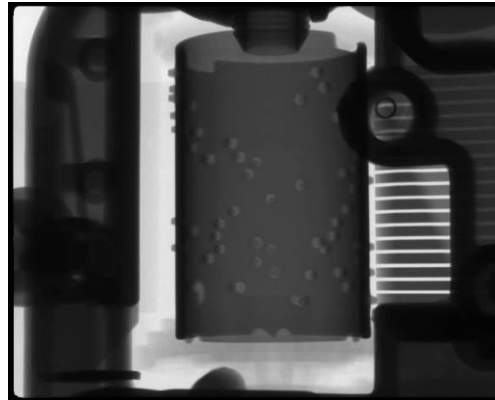

### Defects inside assemblies

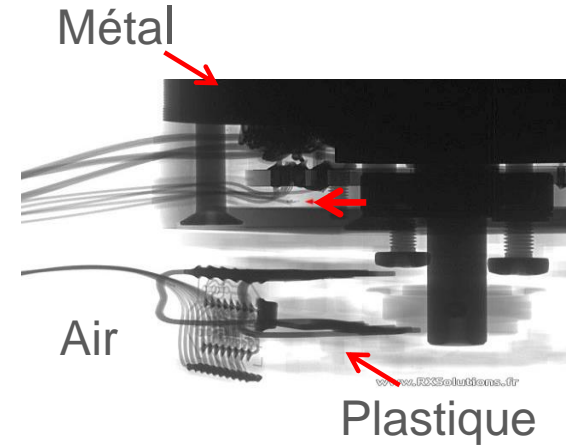

### Internal assembly

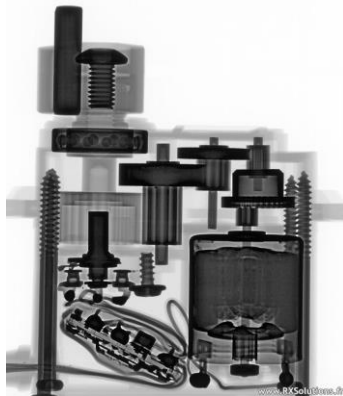

### Welding defects

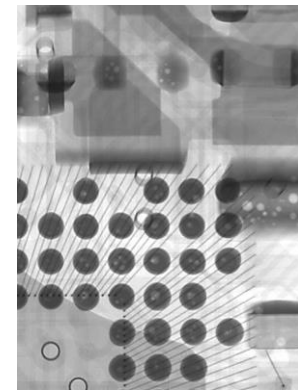

### III. 3D CT scan: first stage: **Radioscopic images acquisition**

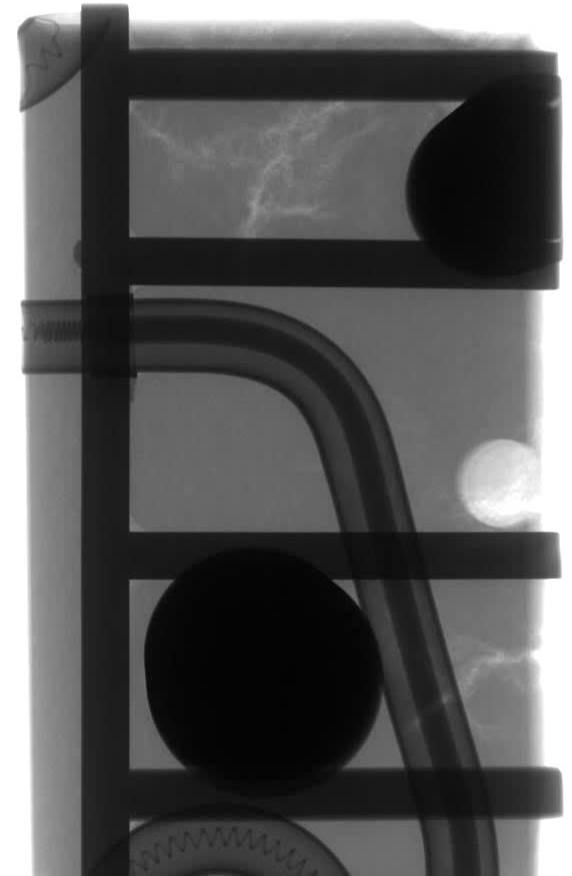
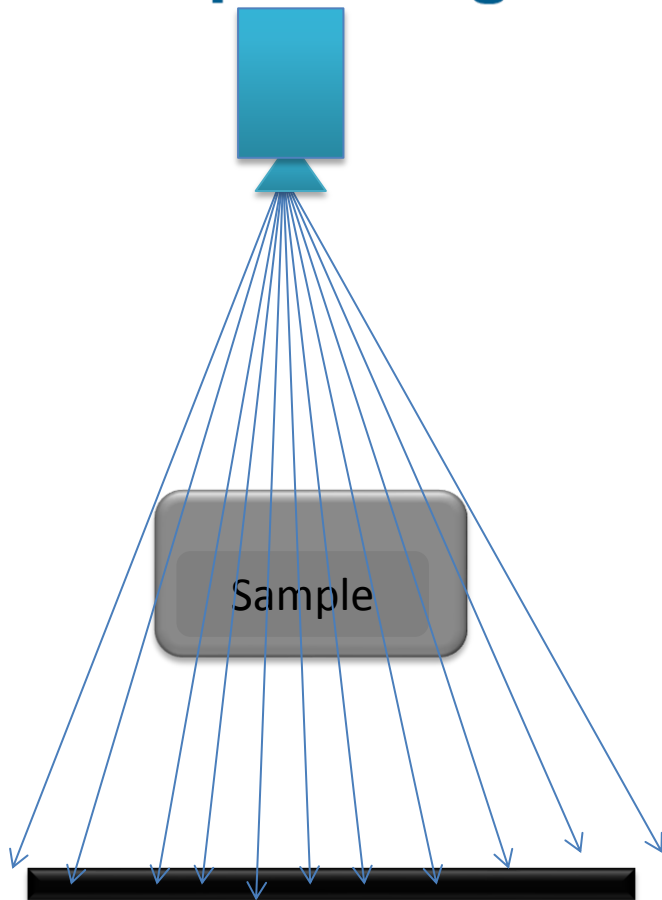

### III. 3D CT Scan second stage : **Reconstruction**

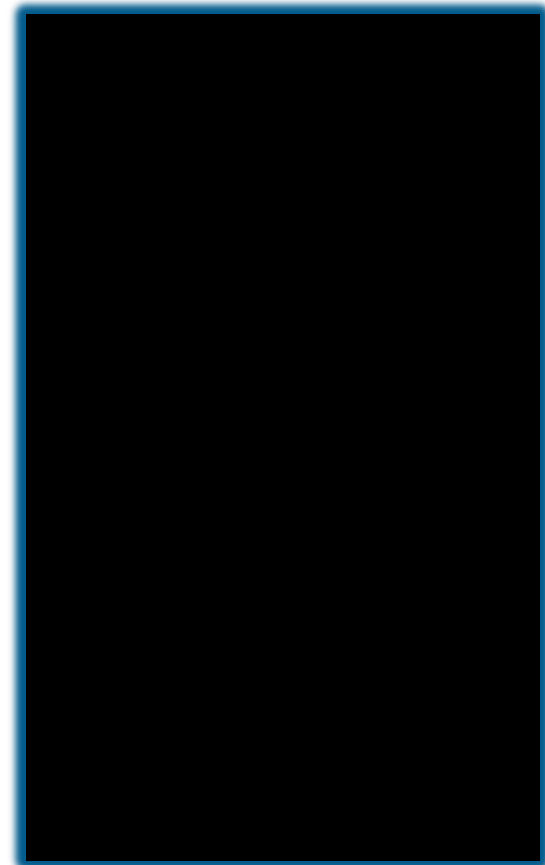

### III. 3D CT Scan: third stage: Post-processing

#### CAD Comparison

Comparison with the CAD file.

#### Stereolithography (STL) file extraction:

Scanning part and extraction of a set of points on the surface.

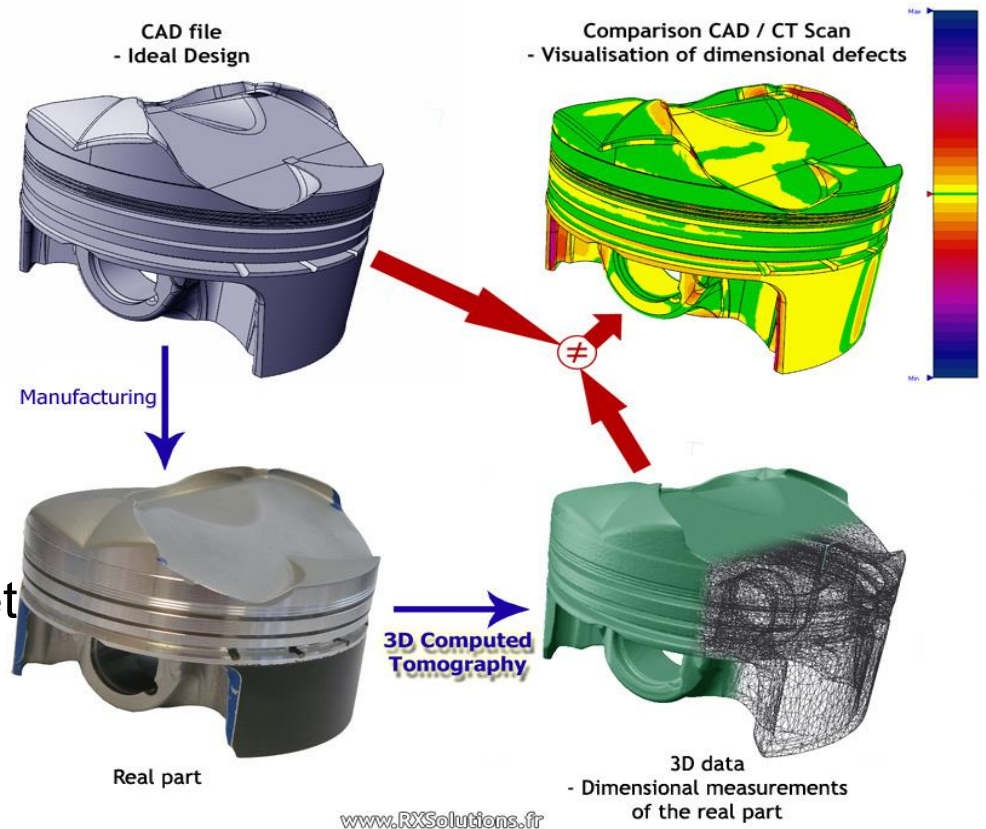



### III. 3D CT Scan: third stage: **Post-processing**

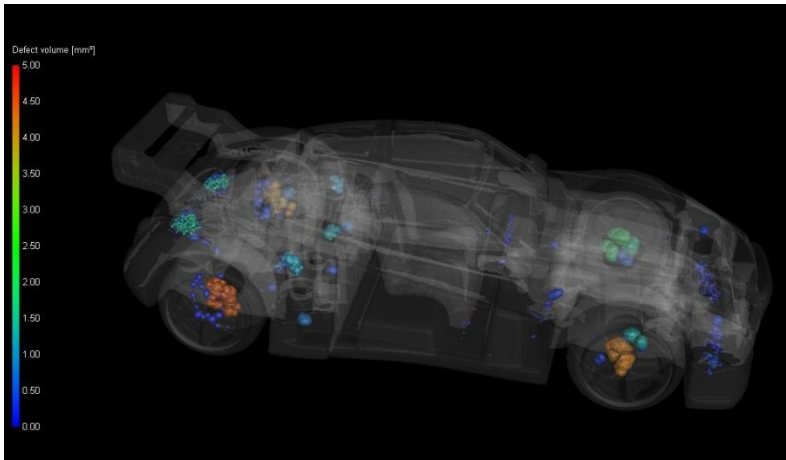

#### **Measurements**

Distance, diameter, angle,  
parallelism,...

#### **Voids analysis**

To determine the position  
and volume of voids  
and/or inclusions

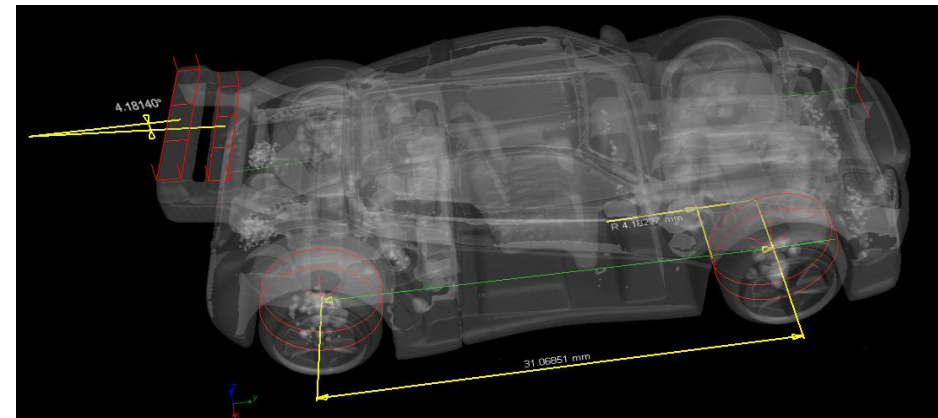

### III. 3D CT Scan: third stage: **Post-processing**

#### **Fiber orientation**

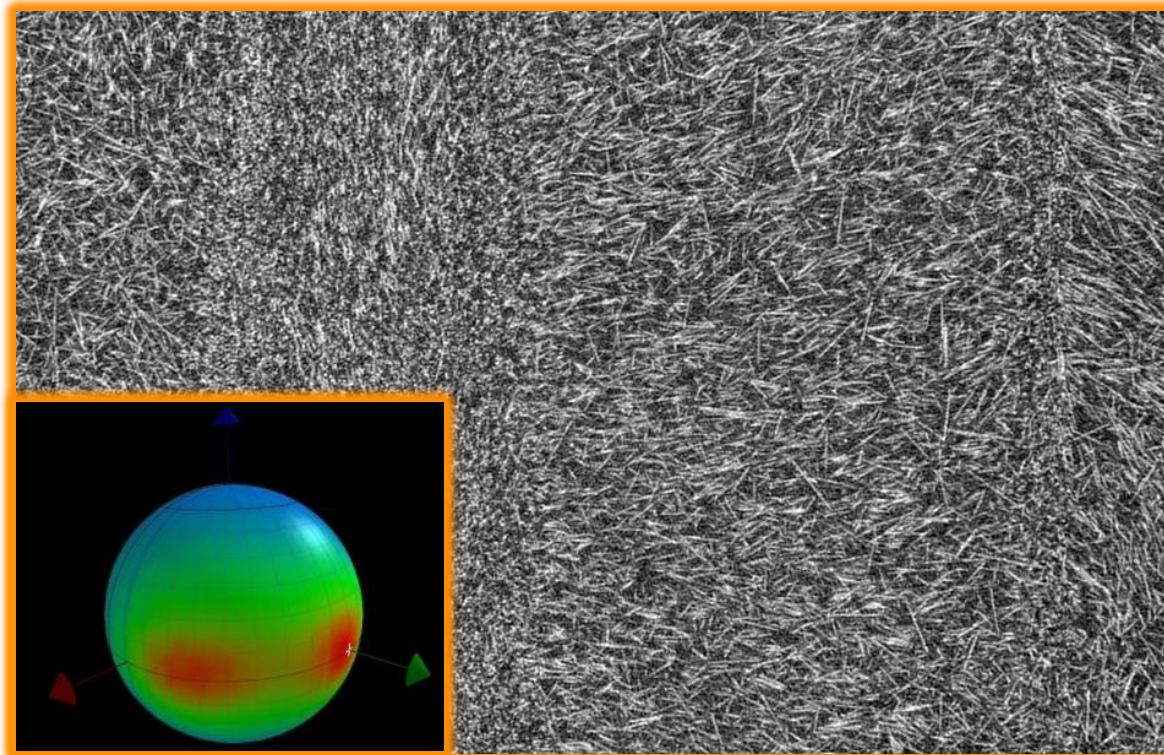

Resolution : 10 microns

### III. Unroll view

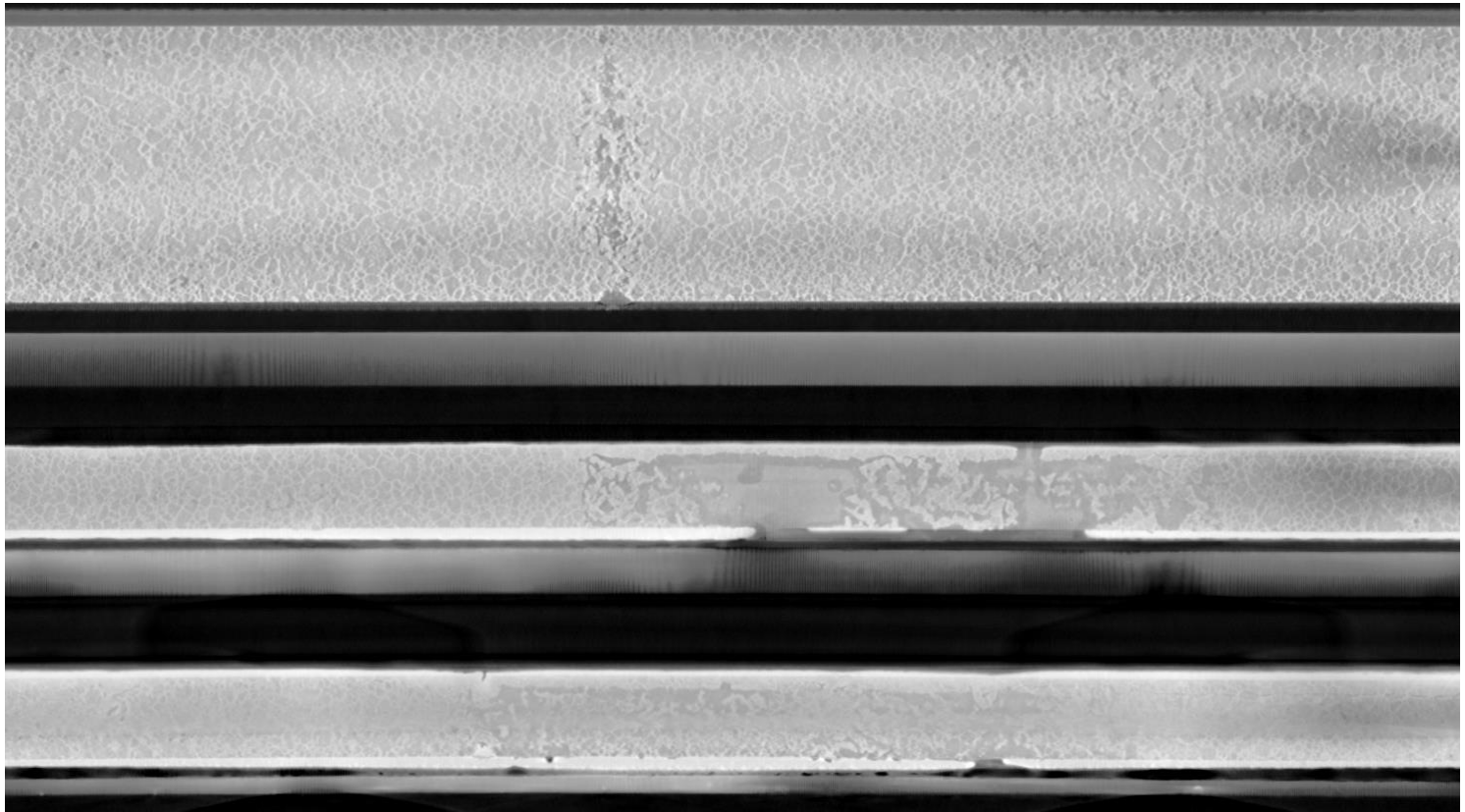

### III. Number of Projections effects

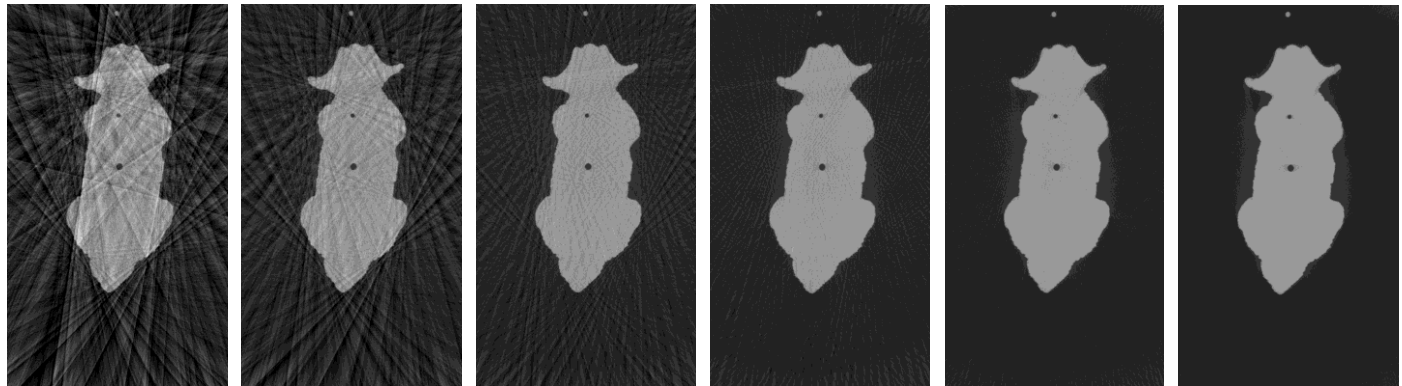

<b>Images</b>	<b>22</b>	<b>44</b>	<b>88</b>	<b>176</b>	<b>352</b>	<b>704</b>
Time	1 min	2 min	4 min	7 min	14 min	27 min



### III. Averaging effects

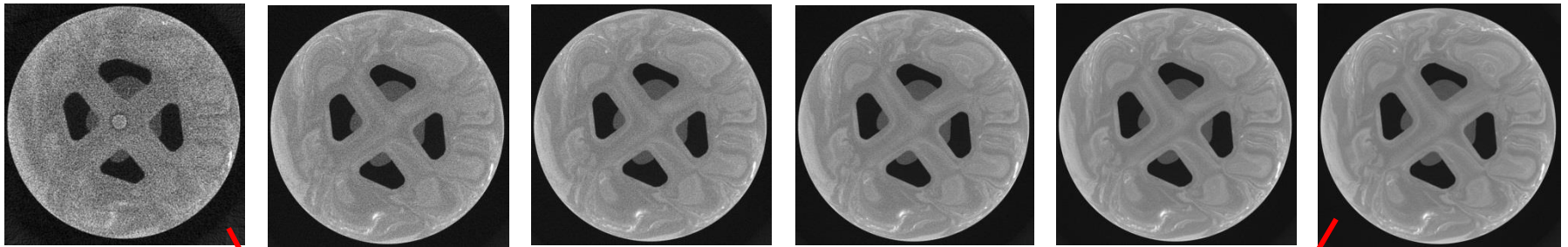

Few secondes

Few minutes

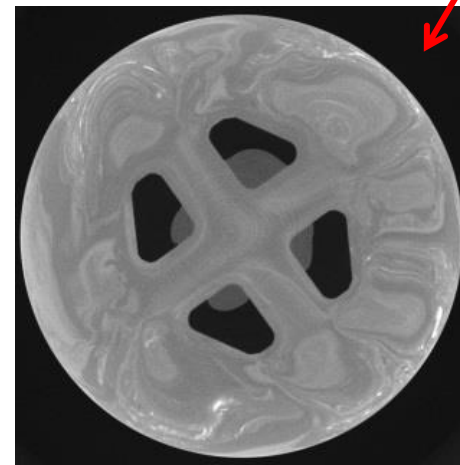
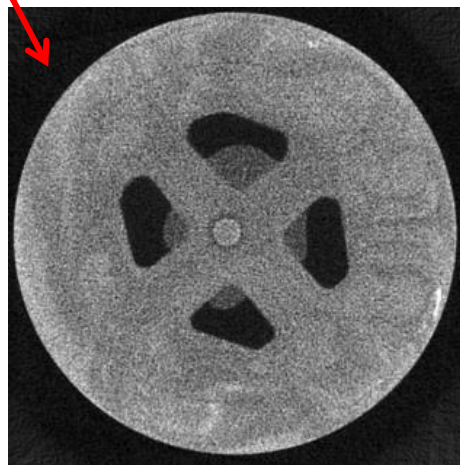

### III. 3D CT Scan: laminography

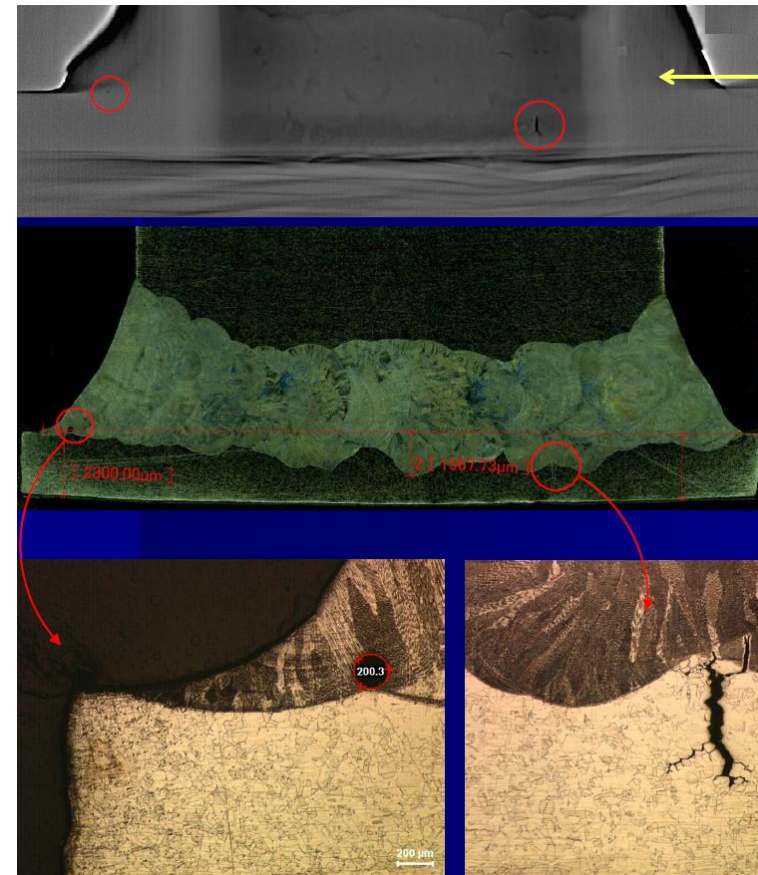
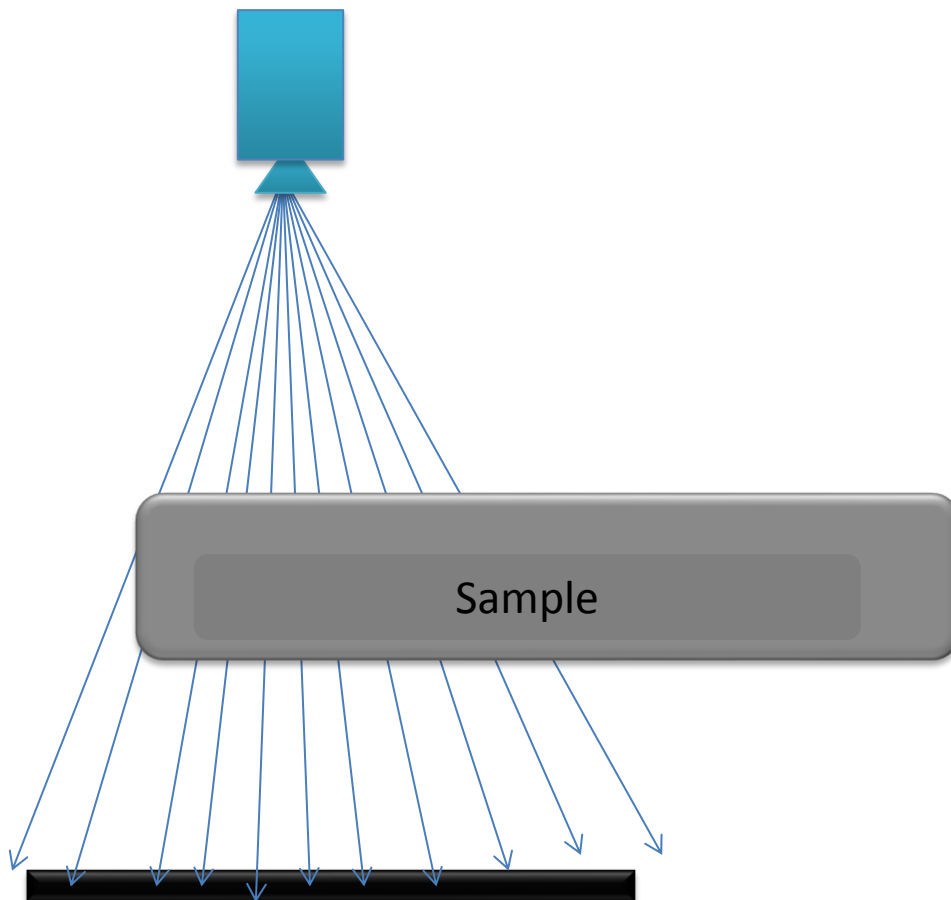

### III. 3D CT Scan: laminography

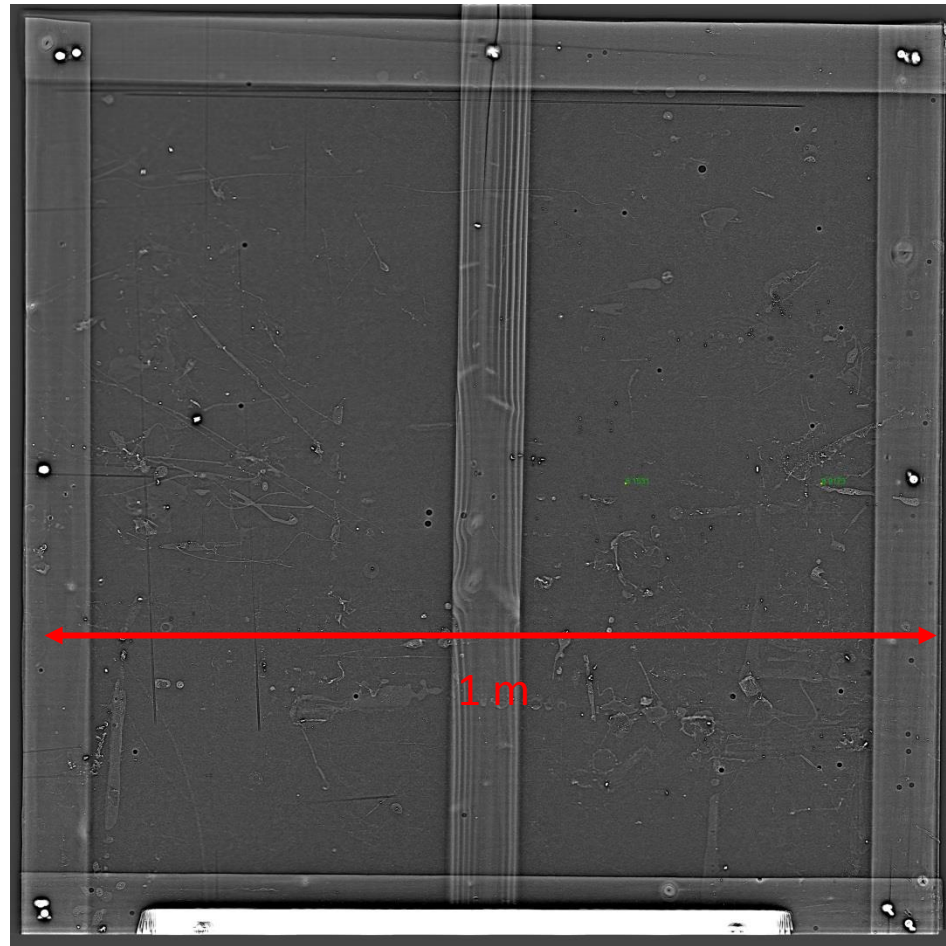

### III. Nanotomography

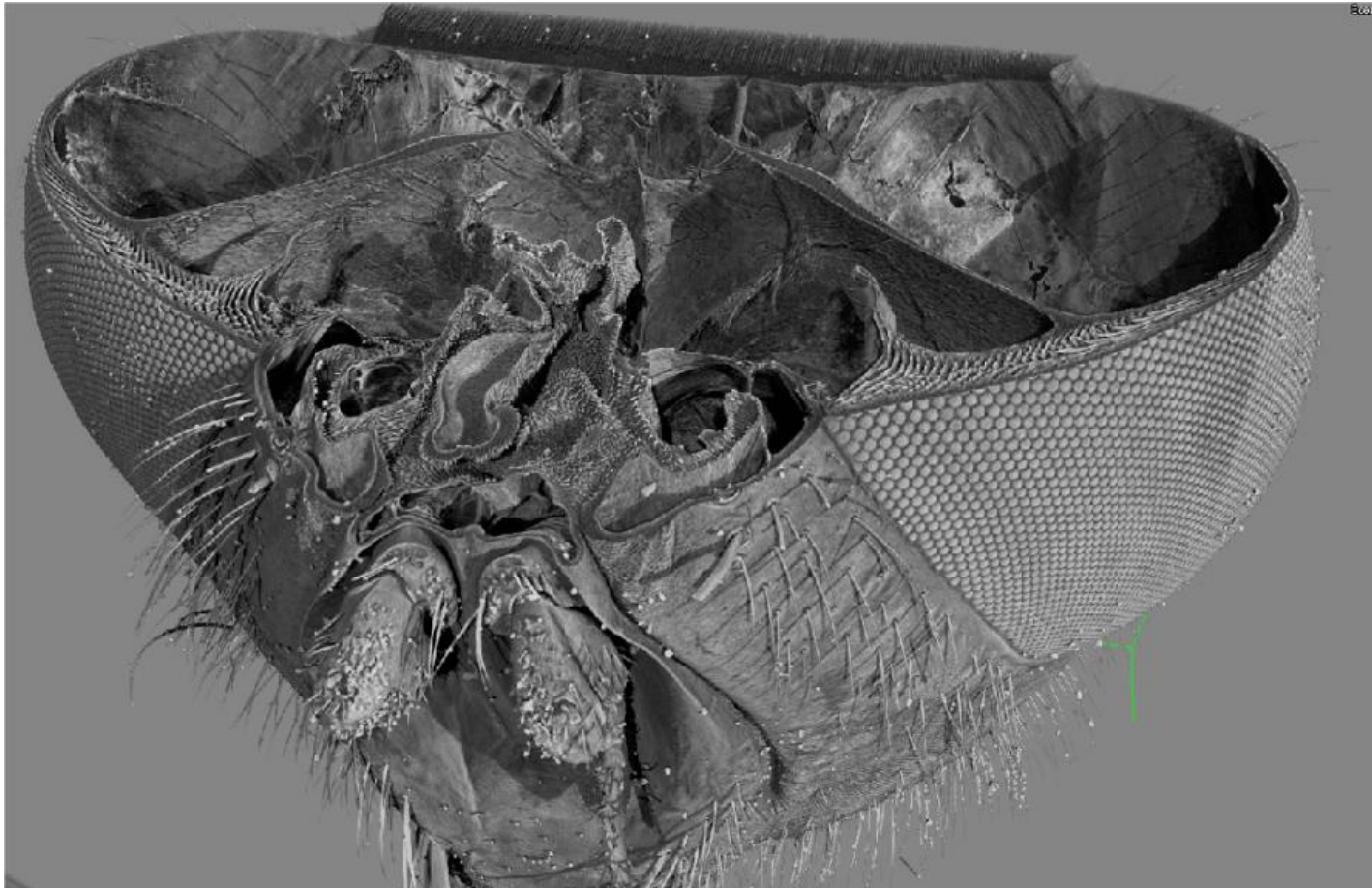



### III. Nanotomography

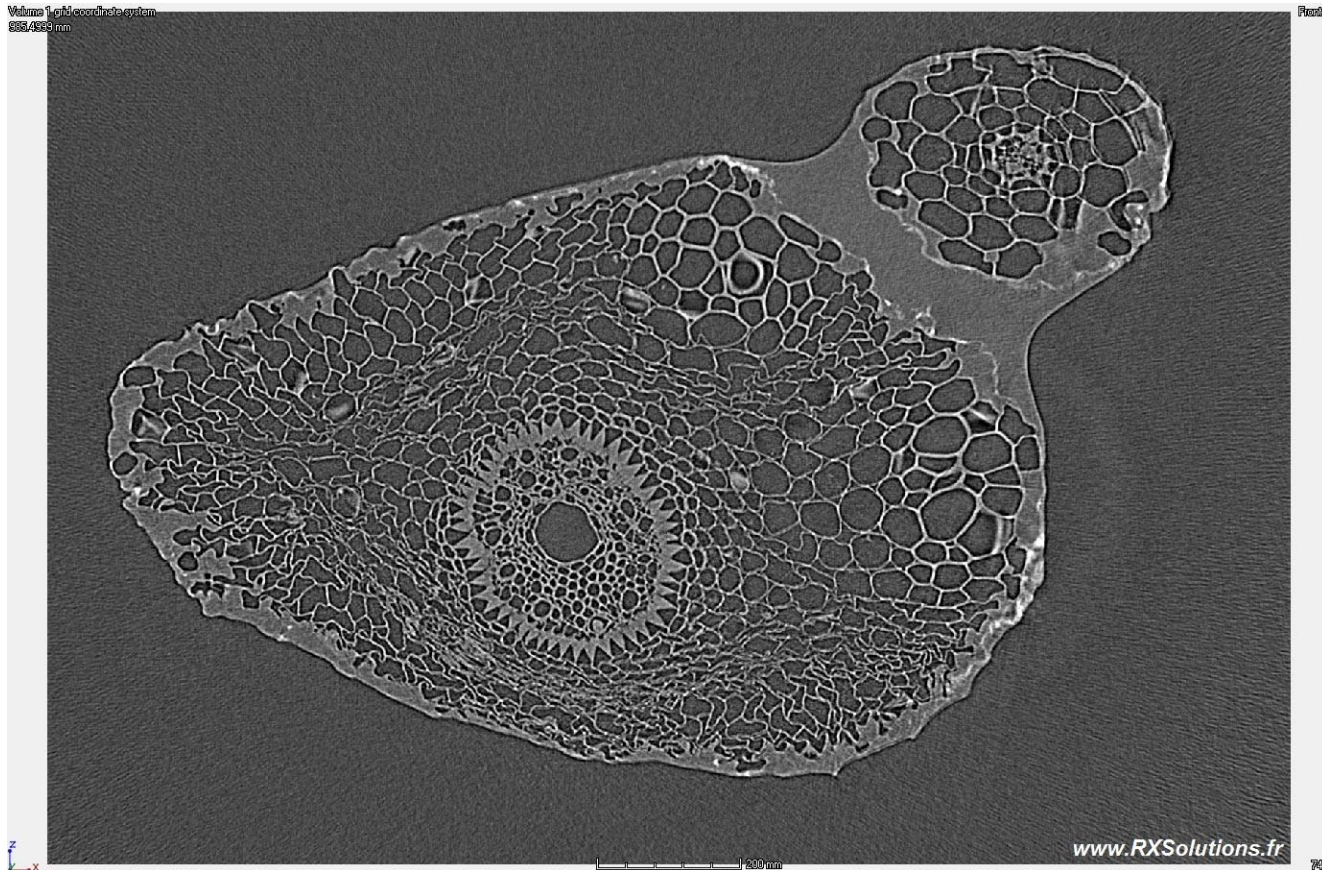

**Thanks for your attention**

**Others informations and movies on**  
**[www.rxsolutions.fr](http://www.rxsolutions.fr)**