

The Long-Baseline Neutrino
Experiment: Taking aim at the
neutrino mass hierarchy, CP violation
and South Dakota

Christopher Mauger

LANL

17 September 2013

Outline

- The Long-Baseline Neutrino Experiment (LBNE)
- Long-Baseline Neutrino Oscillation Physics
- The LBNE Detector Design
- More LBNE Physics
- Conclusions

The Long-Baseline Neutrino Experiment



- Intense neutrino beam at Fermilab
- Near detector systems at Fermilab
- 34 kt liquid argon time-projection chamber (TPC) at Sanford Laboratory at 4850 foot depth – 1300 km from Fermilab

Scientific Motivation

- Neutrino oscillations requires physics beyond the standard model
- Detailed studies of neutrino oscillations will allow us to answer important scientific questions:
 - What is the neutrino mass hierarchy?
 - Do neutrinos violate CP symmetry?
- High precision studies of neutrino oscillation phenomena allow us to test the three-flavor paradigm
 - Do sterile neutrinos exist?
 - Are there non-standard interactions (NSI)
- Building an experiment to address these issues with accelerator neutrinos enables much more science

Scientific Motivation II

- Physics enabled by intense neutrino source and high-precision near neutrino detector
 - Precision electroweak tests
 - Searches for high Δm^2 neutrino oscillation physics
 - Searches for “dark photons”
- Physics enabled by a large, underground far detector
 - Atmospheric neutrino studies
 - complementary oscillation physics studies
 - indirect WIMP searches
 - astrophysical neutrino searches
 - Burst supernova neutrino studies
 - complementary oscillation physics studies
 - supernova physics
 - Beyond the Standard Model nucleon decay studies
 - SUSY, Grand Unified Theories
- And many others, see arXiv:1307.7335 – LBNE whitepaper

The LBNE Collaboration



Alabama
Argonne
Boston
Brookhaven
Cambridge
Catania
Columbia
Chicago
Colorado
Colorado State
Columbia
Dakota State
Davis
Drexel
Duke
Duluth
Fermilab
Hawaii
Indian Group
Indiana
Iowa State
Irvine
Kansas State
Kavli/IPMU-Tokyo
Lawrence Berkeley NL
Livermore NL
London UCL
Los Alamos NL
Louisiana State
Maryland
Michigan State
Minnesota
MIT

NGA
New Mexico
Northwestern
Notre Dame
Oxford
Pennsylvania
Pittsburgh
Princeton
Rensselaer
Rochester
Sanford Lab
Sheffield
SLAC
South Carolina
South Dakota
South Dakota State
SDSMT
Southern Methodist
Sussex
Syracuse
Tennessee
Texas, Arlington
Texas, Austin
Tufts
UCLA
Virginia Tech
Washington
William and Mary
Wisconsin
Yale

- >400 members, 77 institutions, 6 countries
- Co-spokespersons Milind Diwan (BNL), Bob Wilson (CSU)

Fermilab, March 2013

Appearance Oscillograms (NH)

- Left plots: Neutrino oscillations vs energy and baseline for neutrinos (top) and antineutrinos (bottom) for $\delta_{CP} = 0$
- Right: Neutrino oscillations as a function of neutrino energy for different values of δ_{CP} for neutrinos (top) and antineutrinos (bottom) – solar term shown in yellow
- All plots assume Normal Hierarchy

$P(\nu_\mu \rightarrow \nu_e), \text{NH}, \delta_{CP} = 0$

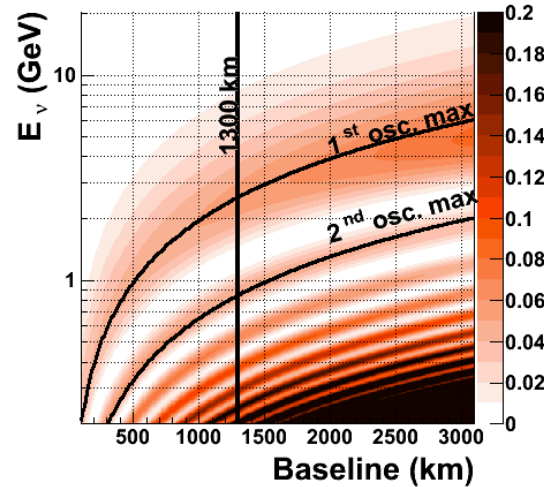

At 1300km

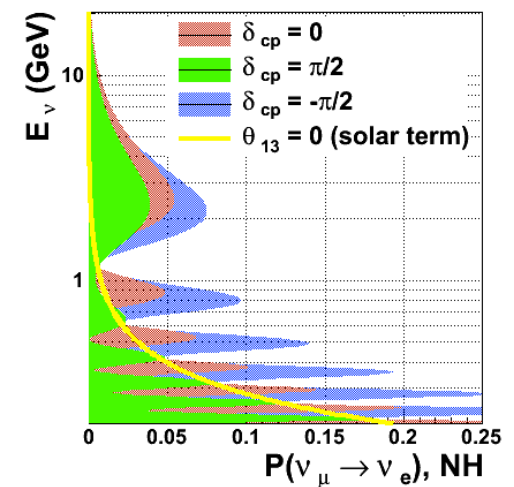

$P(\bar{\nu}_\mu \rightarrow \bar{\nu}_e), \text{NH}, \delta_{CP} = 0$

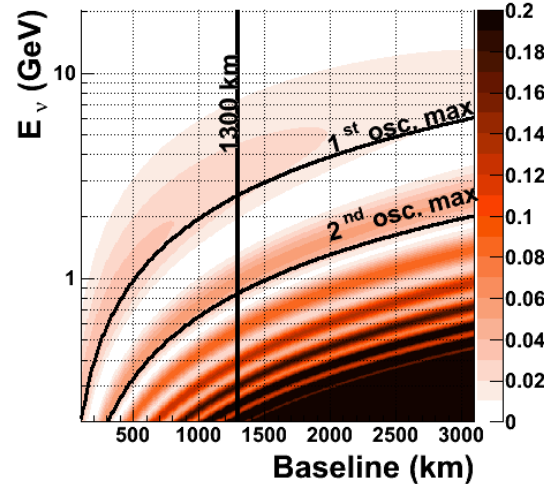

At 1300km

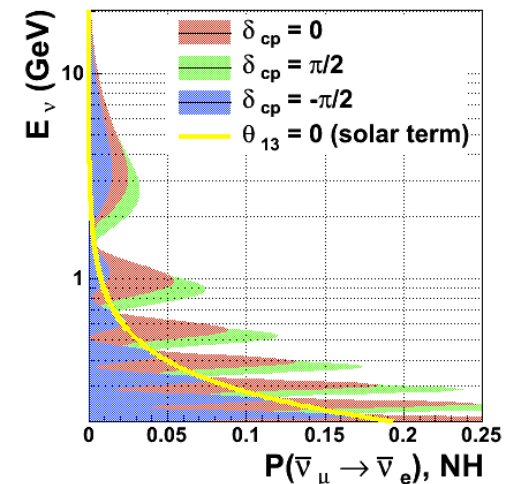

Appearance Oscillograms (IH)

- Left plots: Neutrino oscillations vs energy and baseline for neutrinos (top) and antineutrinos (bottom) for $\delta_{CP} = 0$
- Right: Neutrino oscillations as a function of neutrino energy for different values of δ_{CP} for neutrinos (top) and antineutrinos (bottom) – solar term shown in yellow
- All plots assume Inverse Hierarchy

$P(\nu_\mu \rightarrow \nu_e), IH, \delta_{cp} = 0$

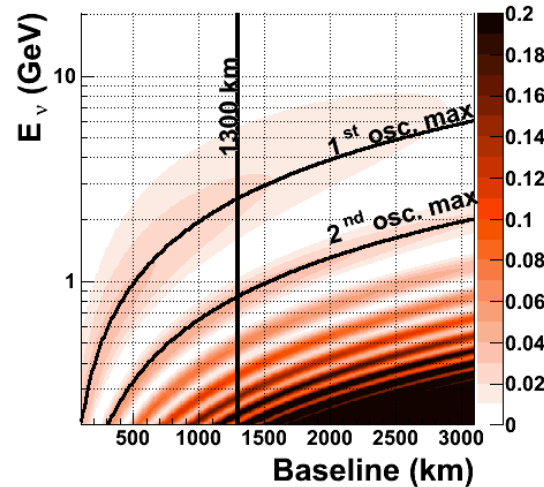

At 1300km

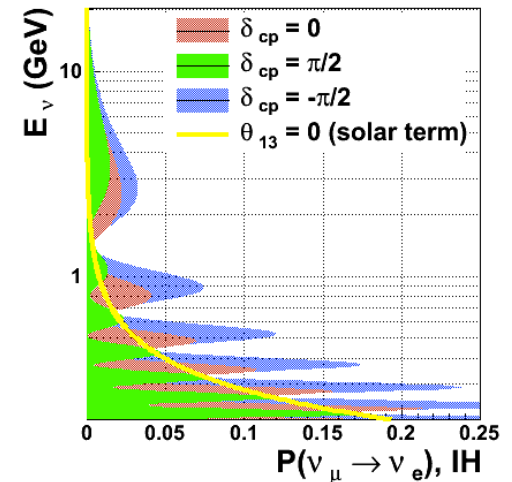

$P(\bar{\nu}_\mu \rightarrow \bar{\nu}_e), IH, \delta_{cp} = 0$

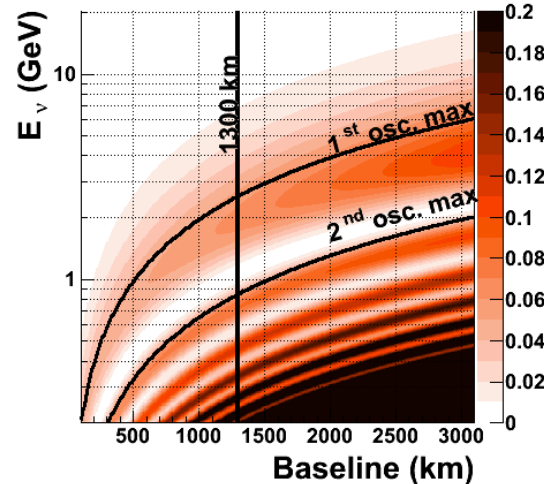

At 1300km

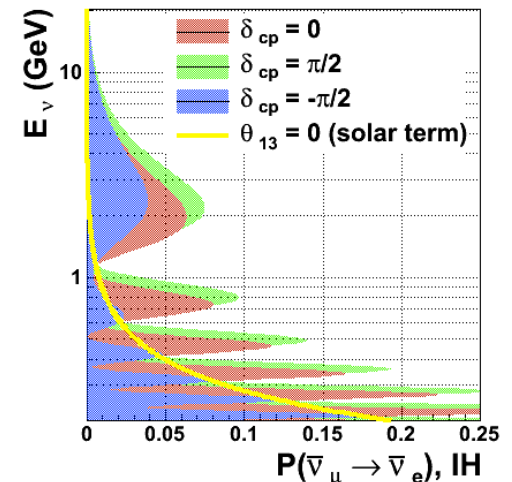

Liquid Argon Time-Projection Chambers (TPCs)

MIP $dE/dx = 2.2 \text{ MeV/cm}$
→ $\sim 1\text{fC/mm}$ @ 500 V/cm
→ $\sim 1 \text{ MeV/wire}$

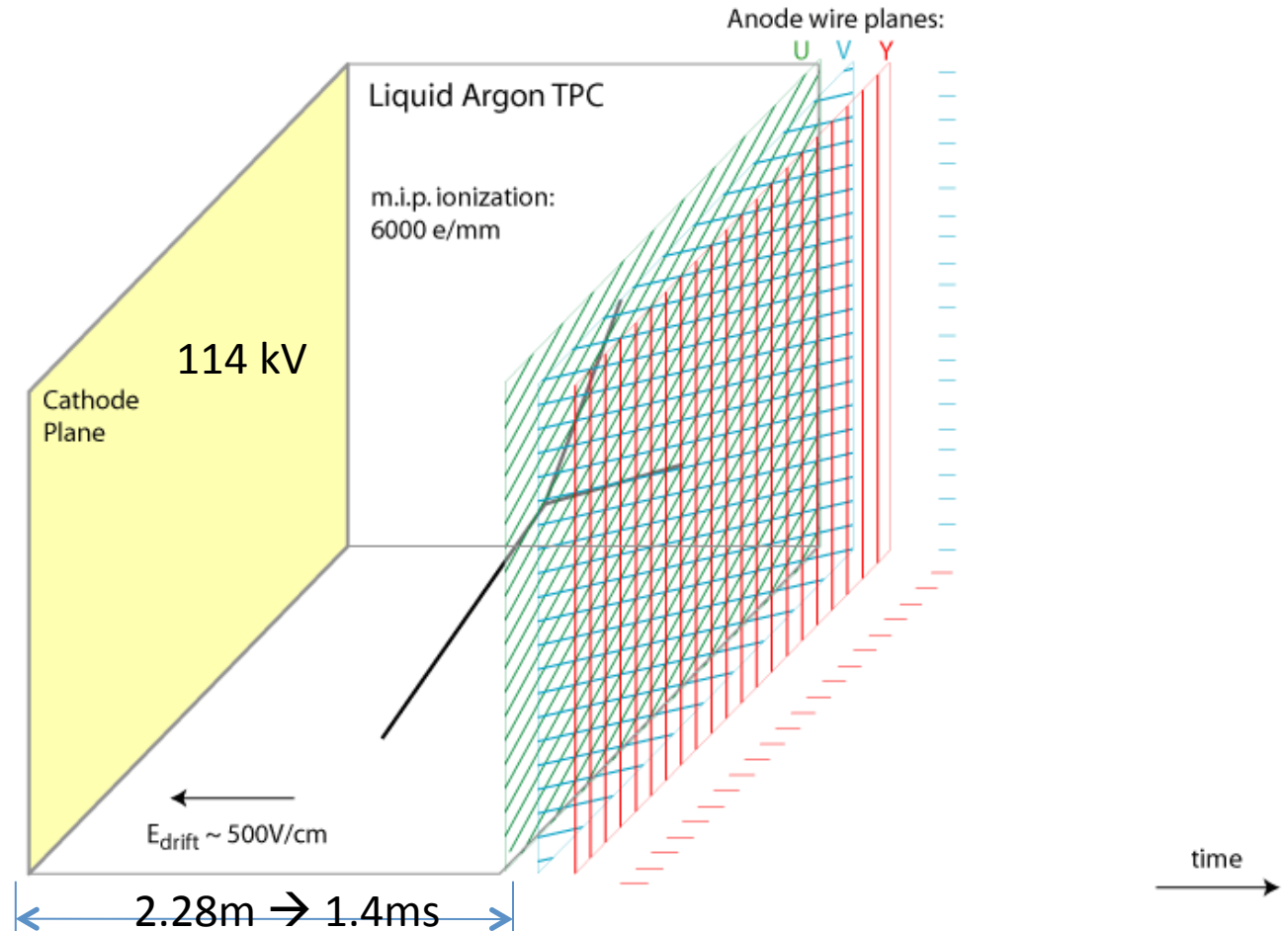

LAr TPC Performance

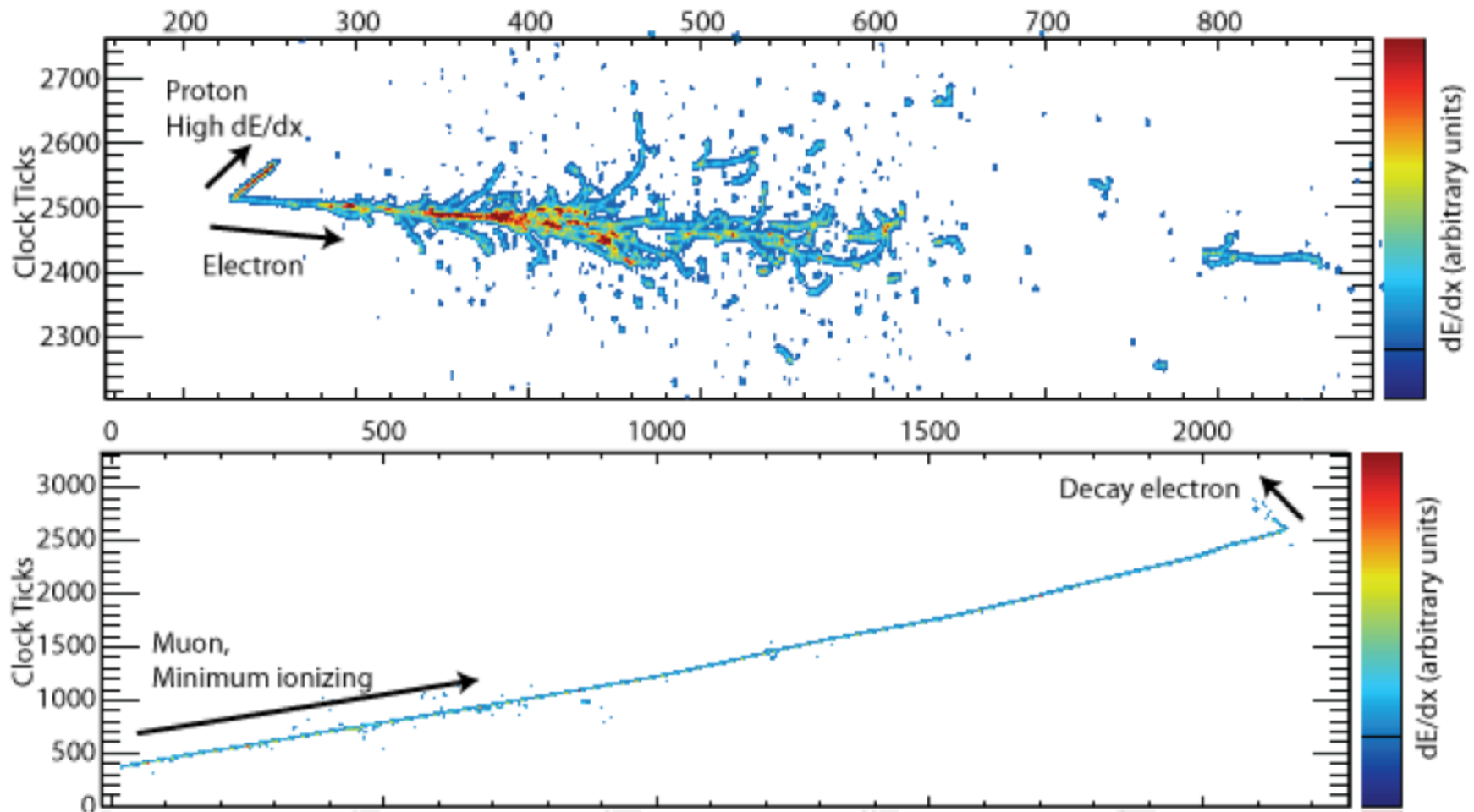

Electron Neutrino Appearance

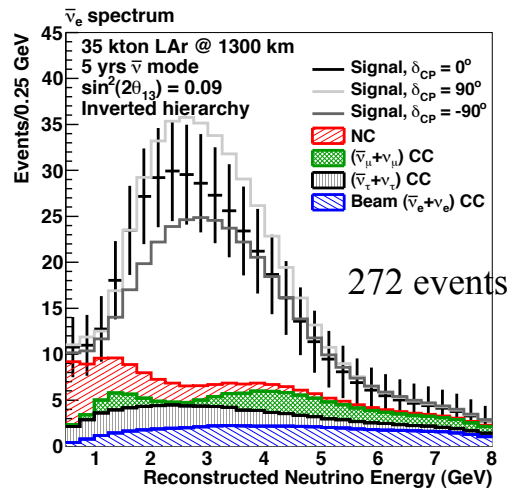
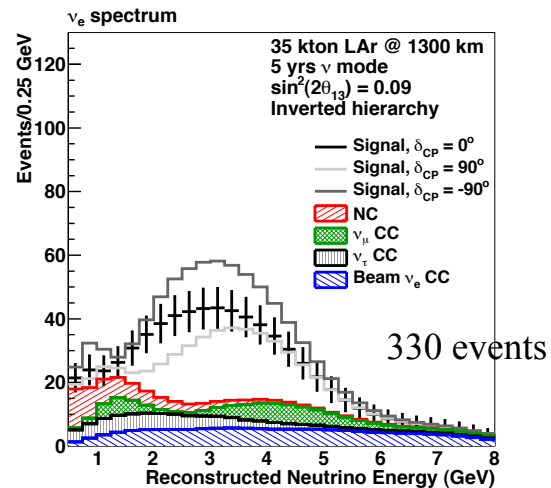
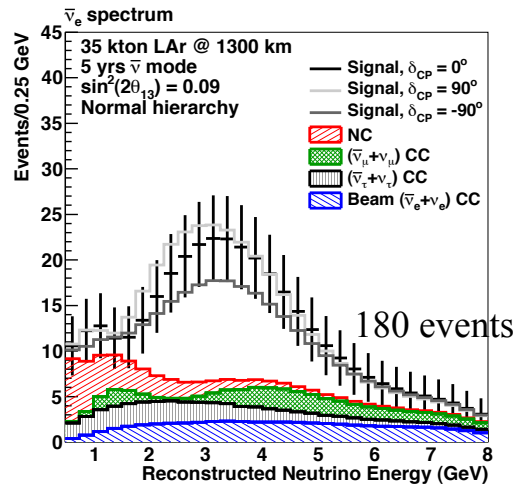
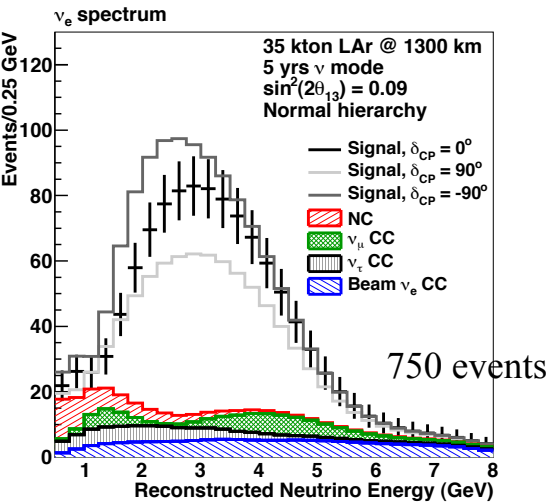

- Electron (anti)neutrino appearance spectra
- Tau neutrino background included
- Assume $\sin^2 2\theta_{13} = 0.09$, 80 GeV proton energy beam, 700 kW, 5 years running in each mode
- Left upper: neutrino, normal hierarchy
- Left lower: neutrino, inverted hierarchy
- Right upper: antineutrino, normal hierarchy
- Right lower: antineutrino, inverted hierarchy

10 kt of LAr is compelling

Mass Hierarchy Sensitivity

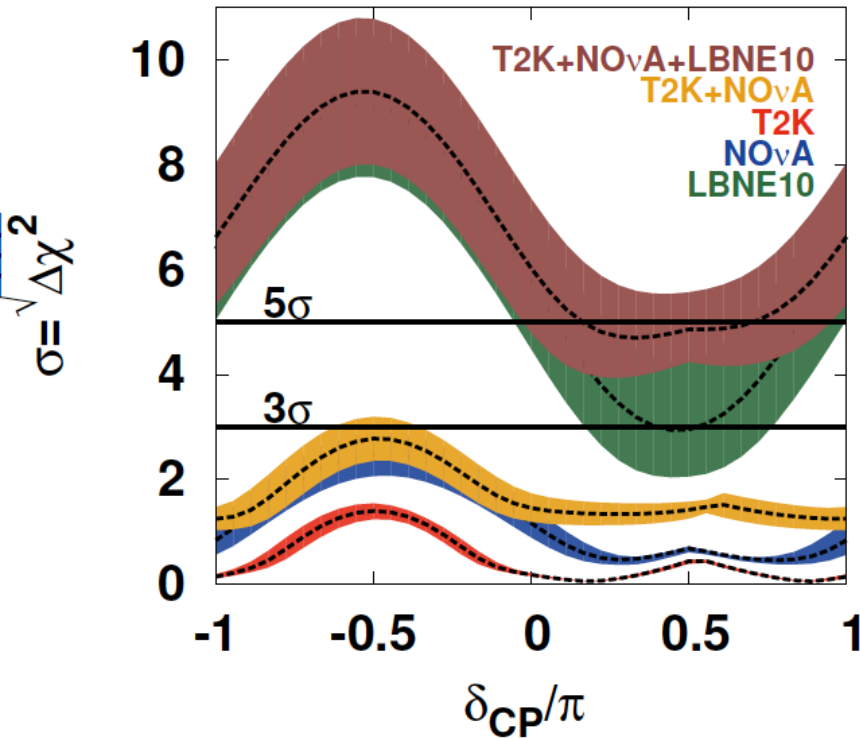

CP Violation Sensitivity

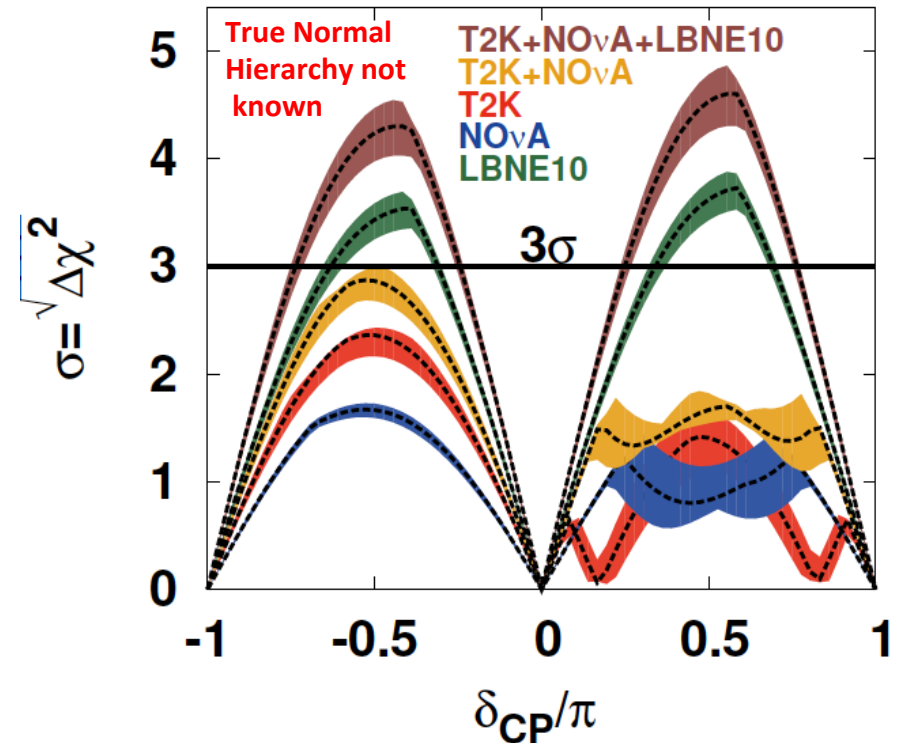

LBNE10 (80 GeV*) 700 kW x (5 yr ν + 5 yr $\bar{\nu}$)

T2K 750 kW x 5 yr (7.8×10^{21} pot) ν

NOvA 700 kW x (3 yr ν + 3 yr $\bar{\nu}$) (3.8×10^{21} pot)

Bands: 1σ variations of θ_{13} , θ_{23} , Δm_{31}^2 (Fogli et al. arXiv:1205.5254v3)

LBNE + Project X (1.1-2.3 MW)

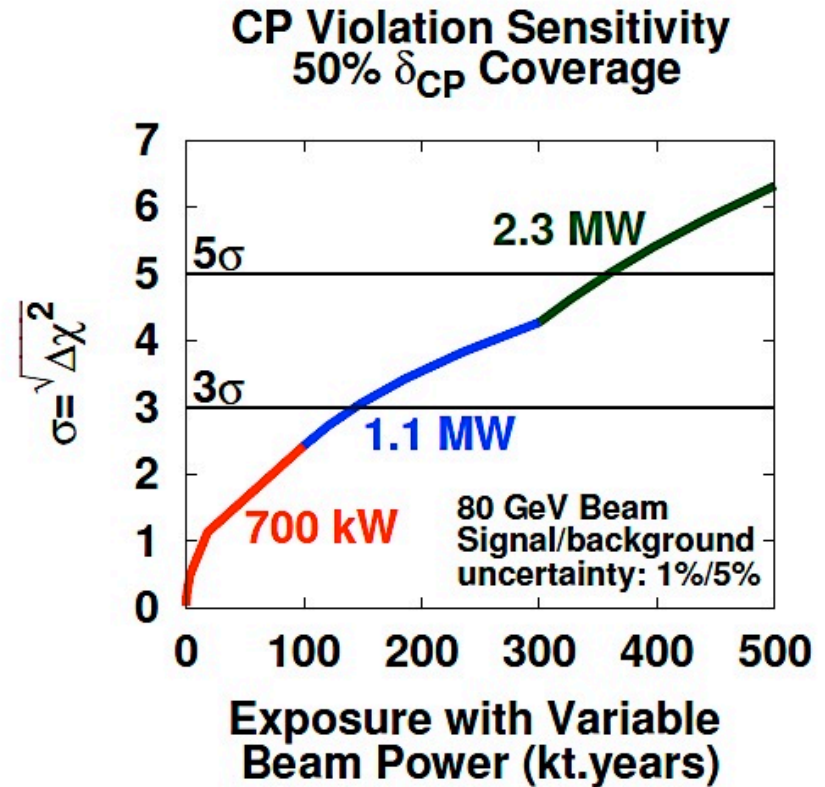
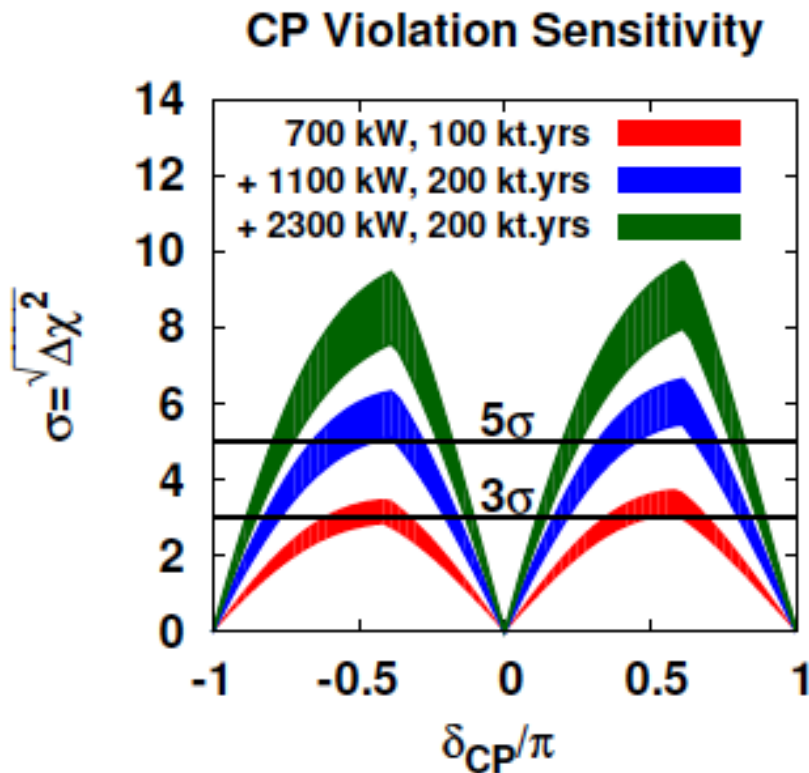

- Comprehensive Global Science Program

Global Context

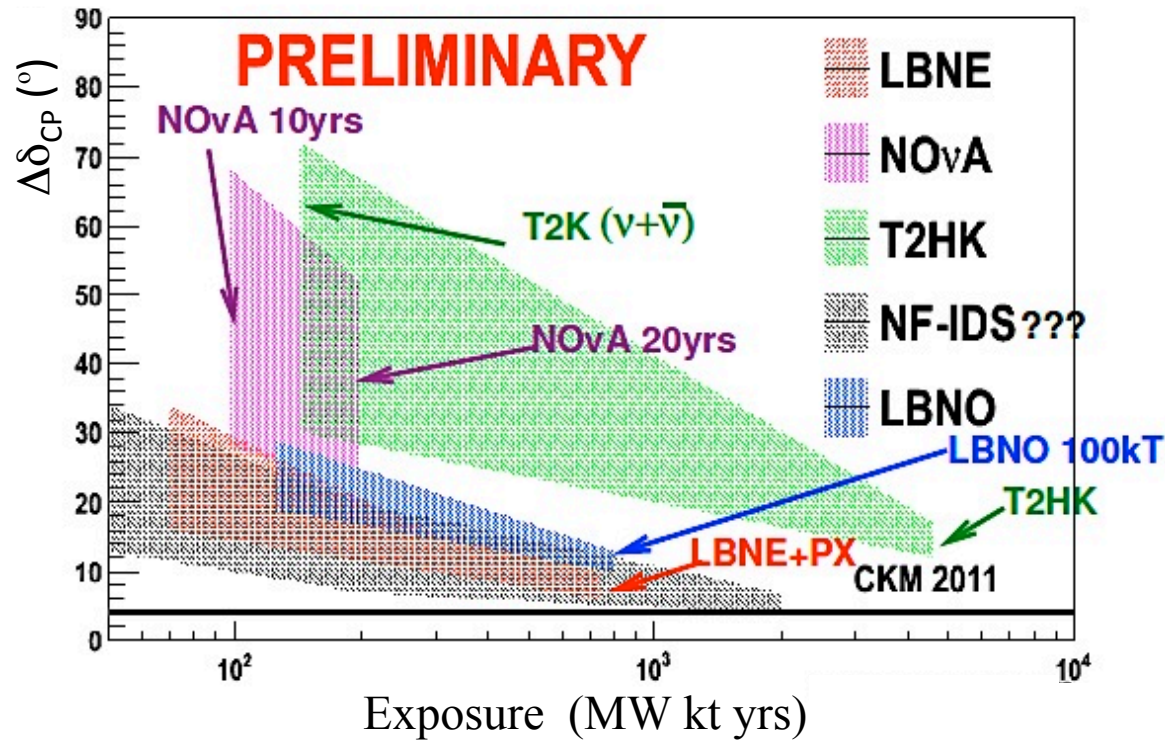

Bands: Range of δ_{CP} (best-worst case)

- LBNE + Project X approach level of precision of CKM matrix

Non-Standard Interactions (NSI)

- Simplifying framework:
- a single term: a flavor changing $qq \nu_\theta \nu_\tau$ interaction
- subdominant to the SM weak interactions

$$H_{mat}^{flav} = \sqrt{2}G_F n_e \begin{pmatrix} 1 & 0 & |\epsilon_{e\tau}| e^{-i\delta_\nu} \\ 0 & 0 & 0 \\ |\epsilon_{e\tau}| e^{i\delta_\nu} & 0 & 0 \end{pmatrix}$$

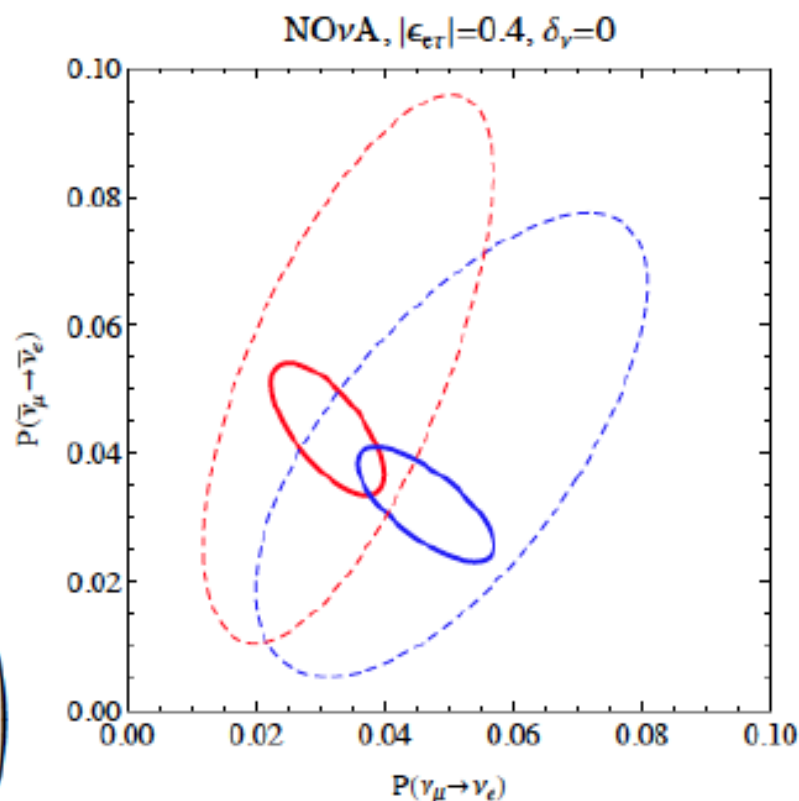

Alex Friedland

NSI: Breaking degeneracy

- LBNE spectral measurements can break the degeneracy

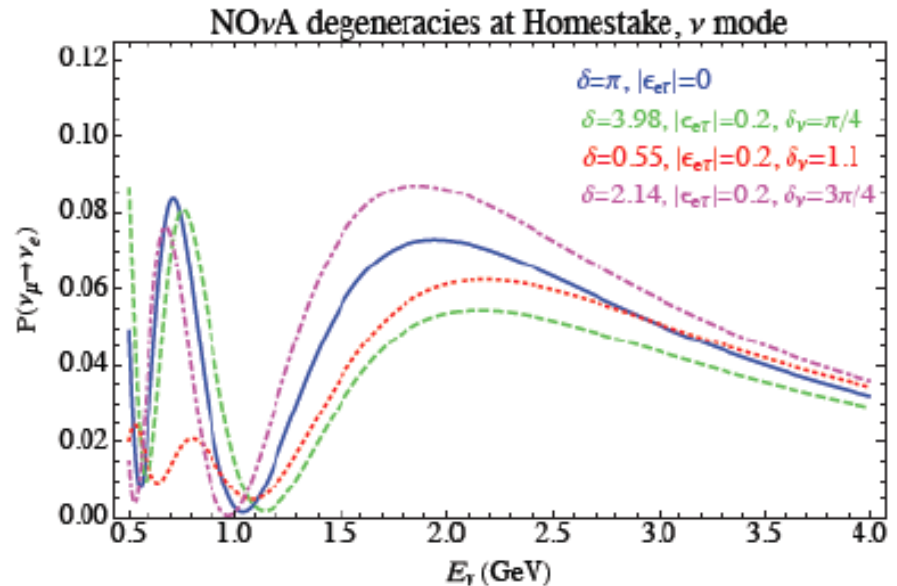
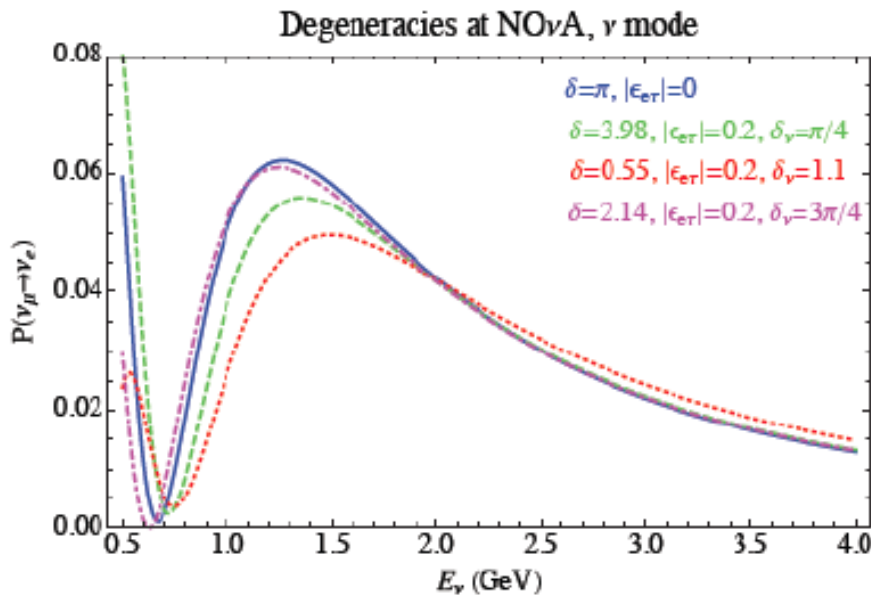

Requires a high precision near neutrino detector

From A. Friedland

Near Detector Systems (NDS)

Cross-section of NDS Layout

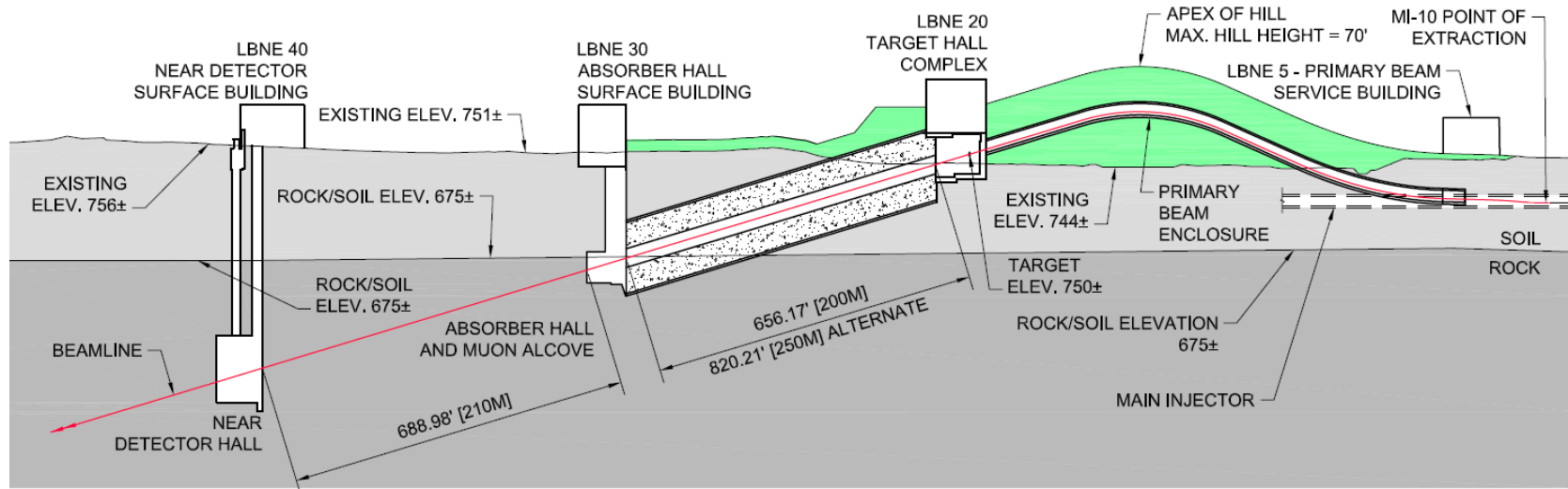

- Two sets of detector systems:
 - Measure muons after the absorber
 - Measure neutrinos

Plan View of NDS Layout

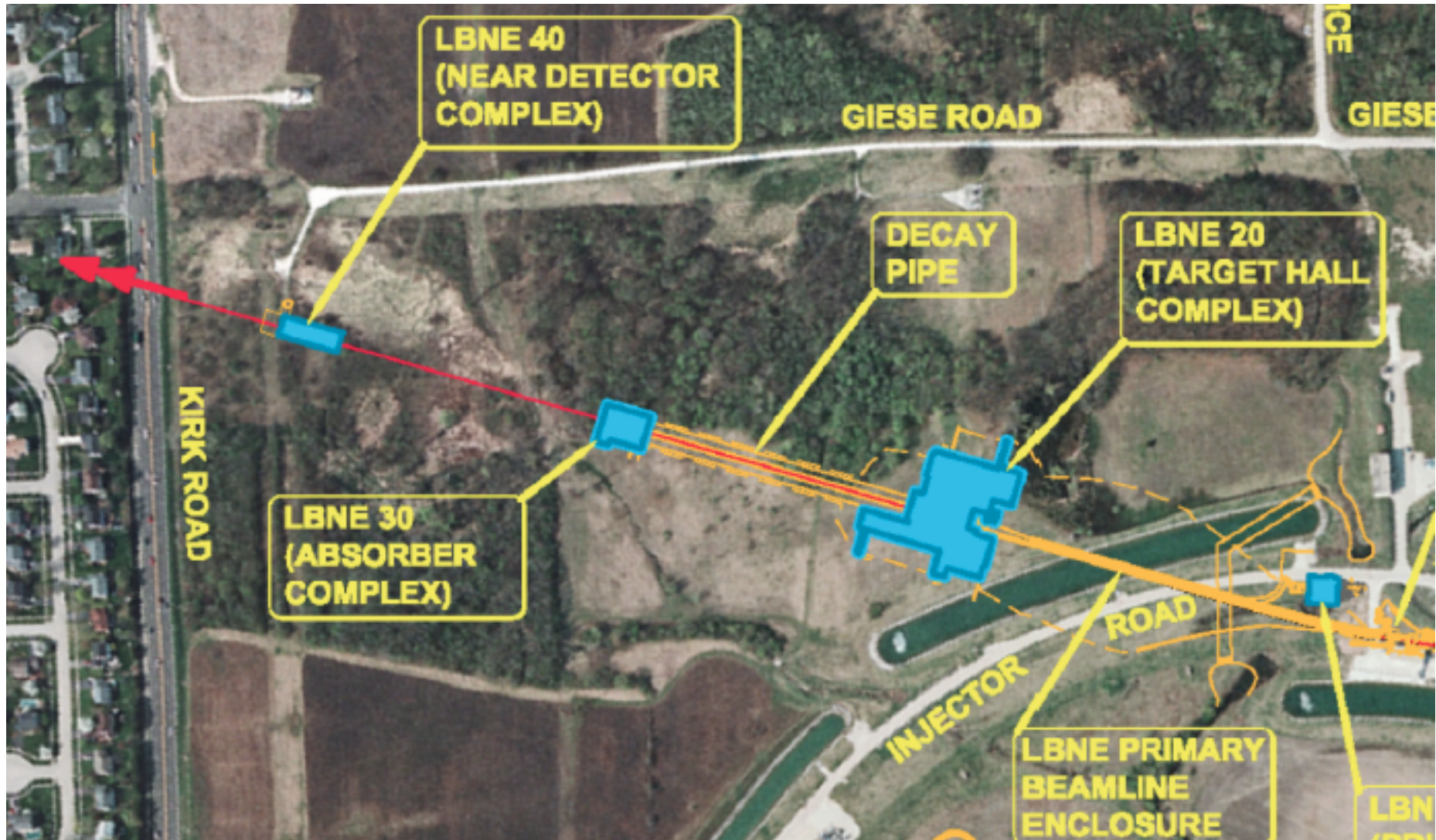

Measurements of muons post-absorber

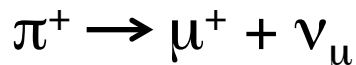

$$\circ E_\nu = (0-0.43)E_\pi$$

$$\circ E_\mu = E_\pi - E_\nu = (0.57-1.0)E_\pi$$

Cherenkov Detectors:

measure all muons above a variable threshold
constrains muon spectrum (correlated with E_ν)

Michel Decay Detectors:

measure muons that stop at a given depth in material
constrains muon spectrum

Ionization Chambers:

spill-by-spill beam profile

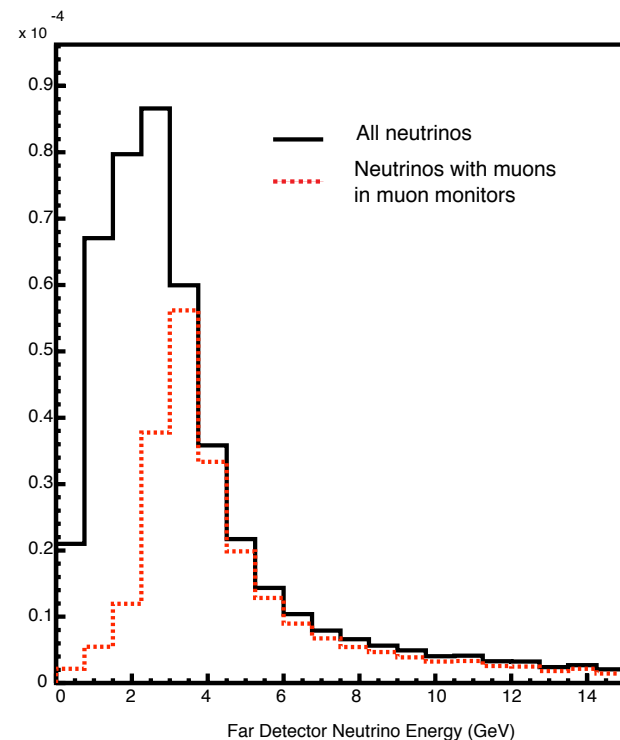
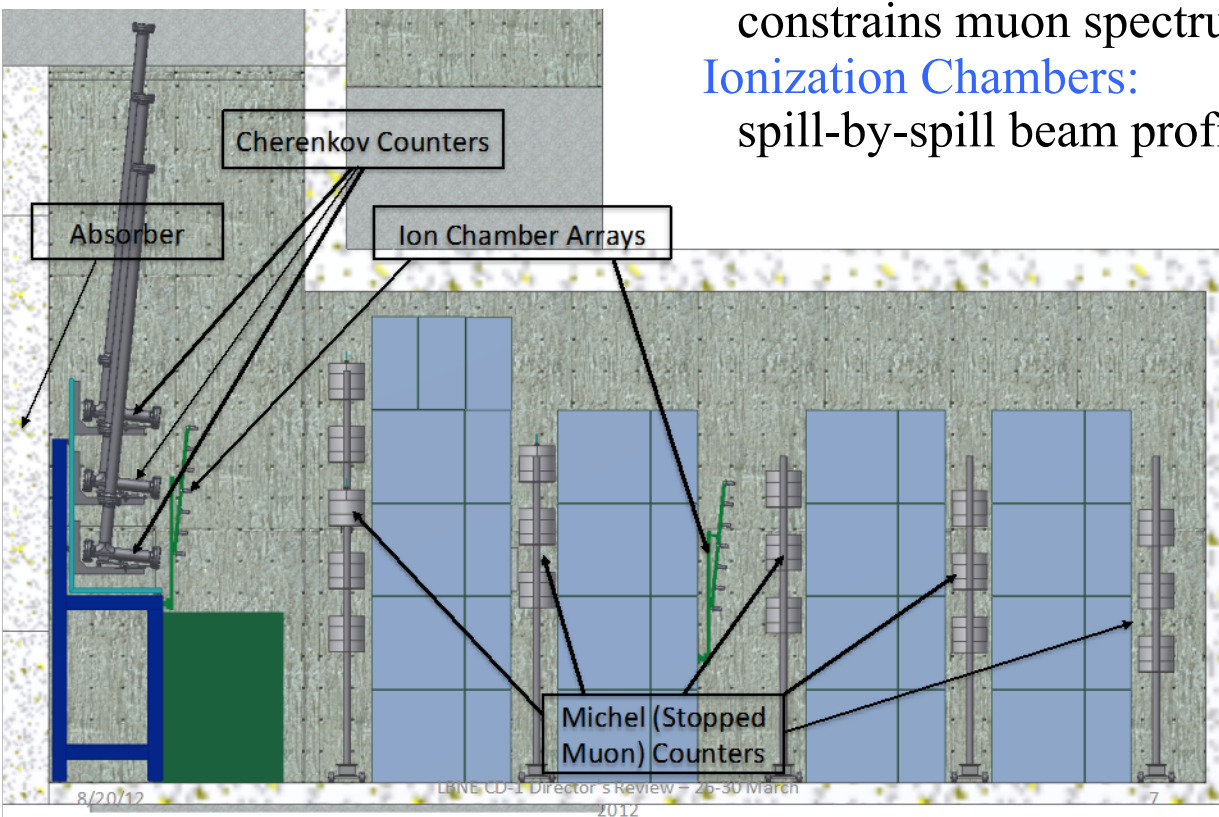

Near Neutrino Detector

- High precision straw-tube tracker with embedded high-pressure argon-gas targets
- Philosophy
 - make high-precision, high-statistics measurements of neutrino interactions with argon (far detector target nucleus)
 - measure inclusive and exclusive cross-sections to build and constrain models to predict the event signatures at the far site *and correlate them with true neutrino energy*
 - make detailed studies of electron (and muon) neutrino and anti-neutrinos separately

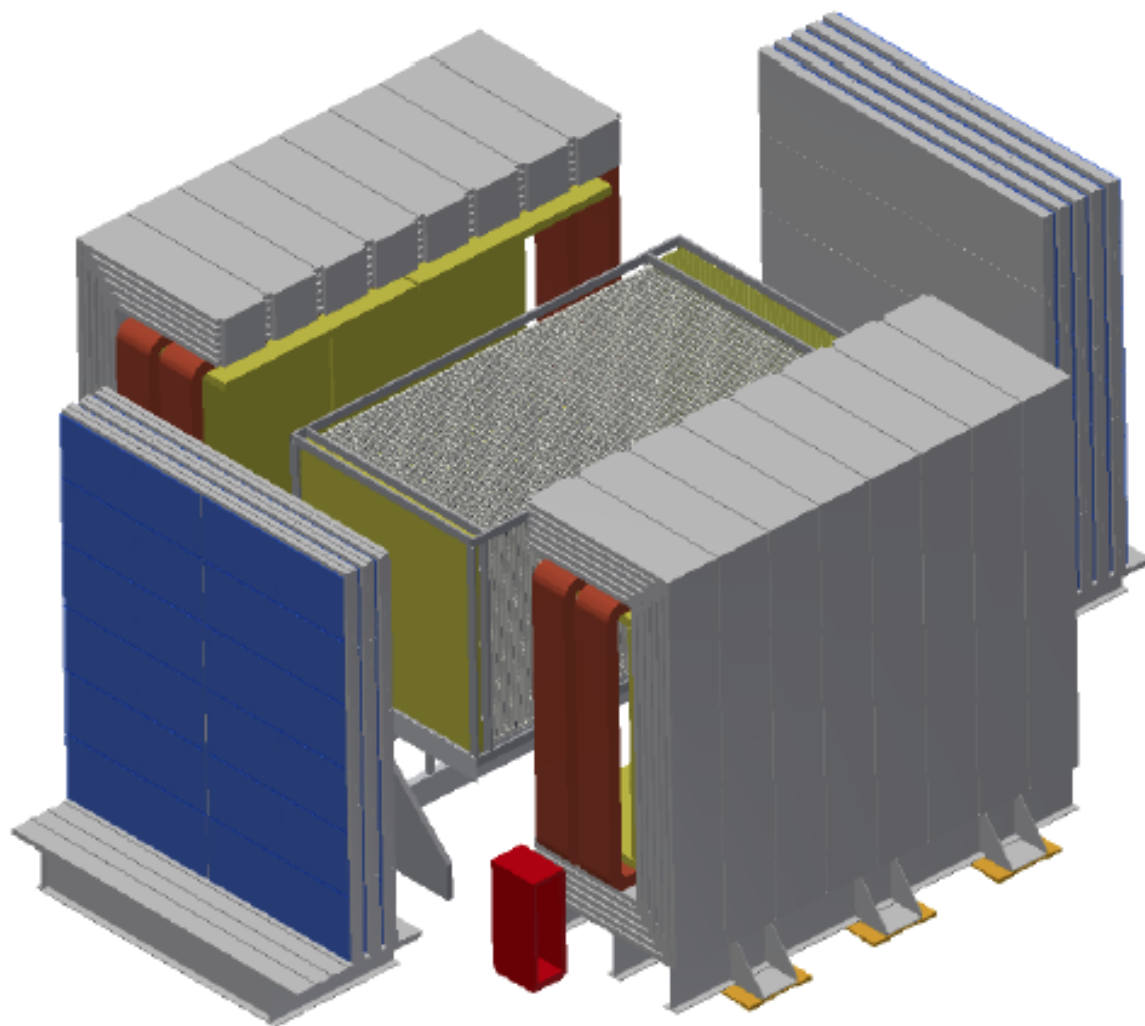

Alternate Design

- Smaller (than the far detector) liquid argon TPC
- Philosophy
 - make high statistics measurements of event signatures in the same technology of the far site
 - try to minimize detector/reconstruction-related systematic uncertainties by using the same technology as the far site
 - magnetization allows for charged muon separation for separate neutrino and antineutrino studies

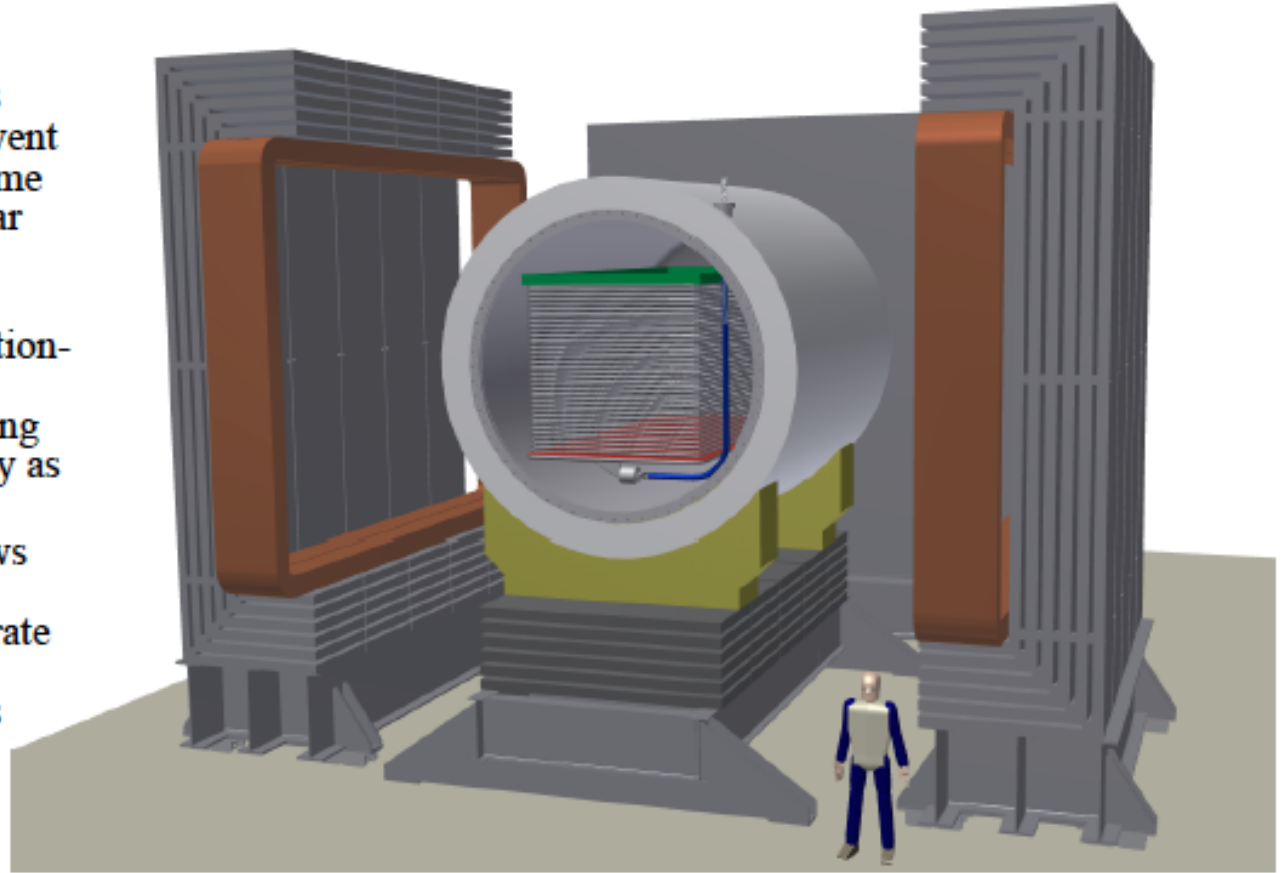

Light Dark Matter Search

- Motivated by non-observation of SUSY, non-observation of direct detection experiments
- Simplest model, U(1) gauge field mixes with SM U(1) gauge field (dark photon)
- Can be produced when protons strike the LBNE target and decay into light (mass) dark-sector particles

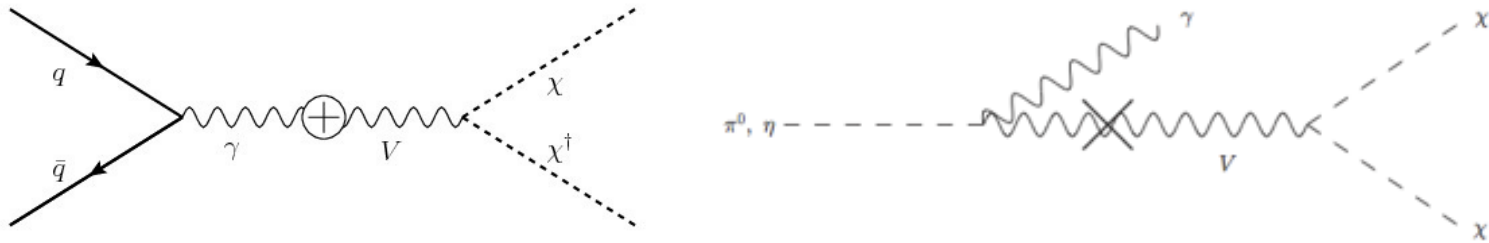

- Detectable in a neutrino detector – neutrino-like NC-like interactions
- Very forward electrons with late timing (mass much heavier than neutrinos)
- Special runs with no focussing would reduce the neutrino background

Far Detector

34kt fiducial mass LAr TPC
at 4850' L (1.5km)
50kt total Ar mass

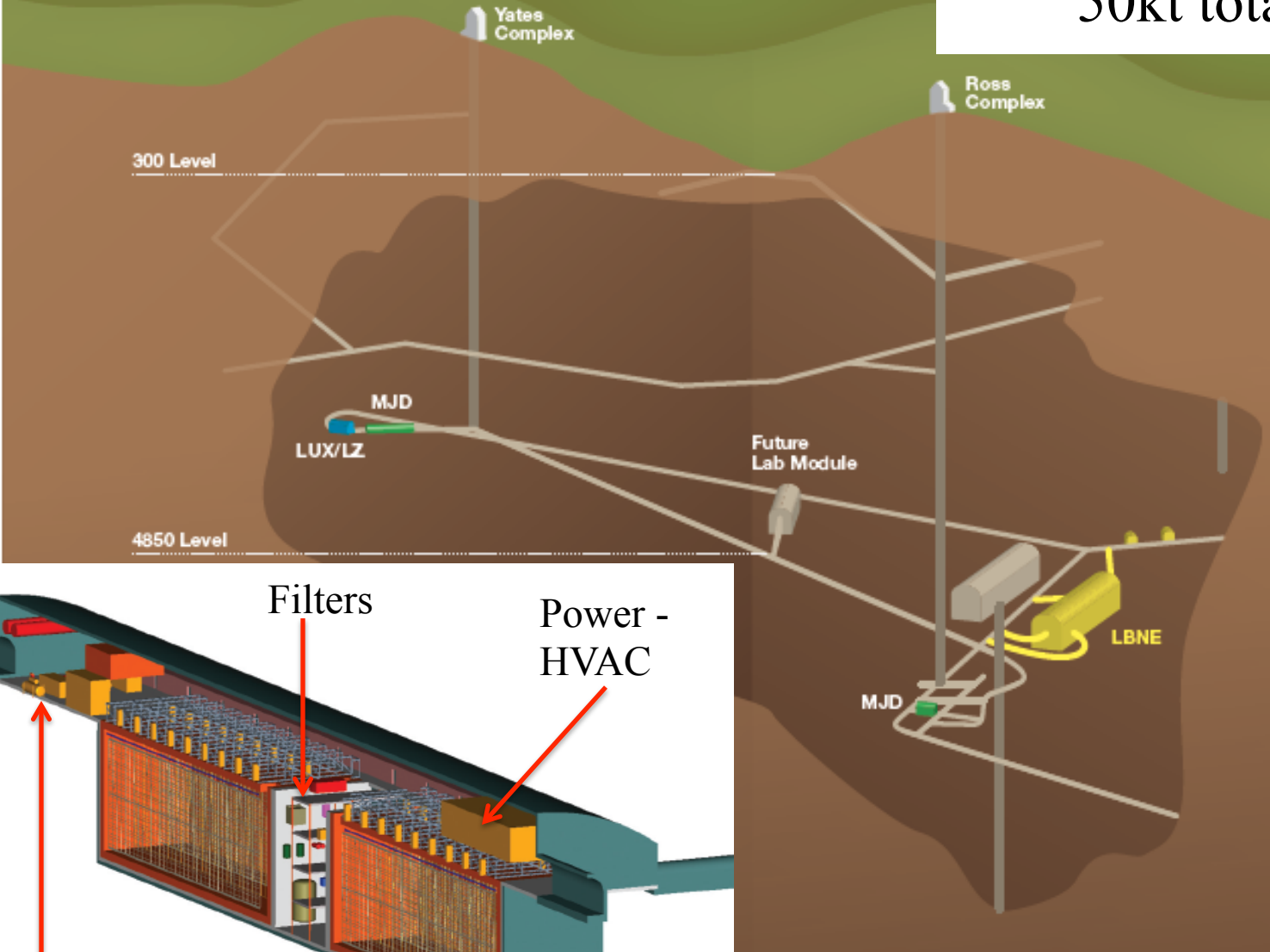

Location suitable for
10 to 100 kt of LAr

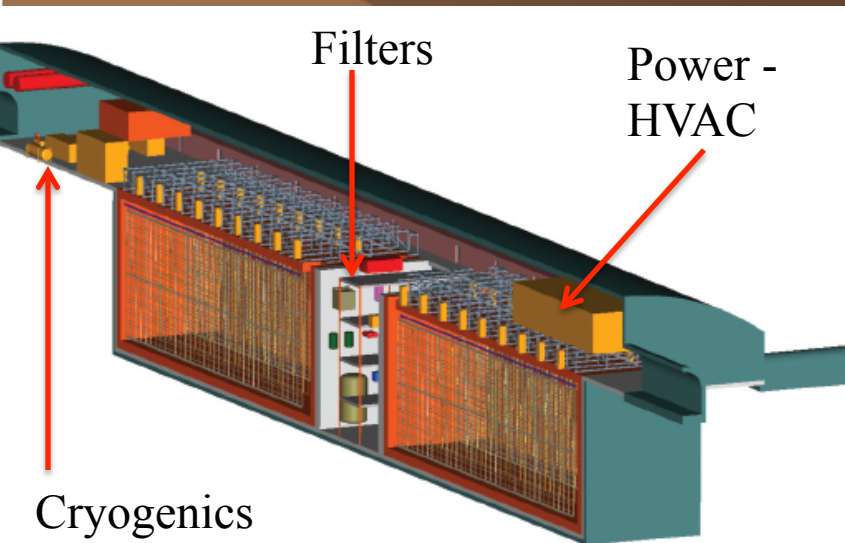

Cryostat Design



The LNGC "Tembek", one of the thirty-one 216,000 m³ LNG carriers ordered by Nakilat and delivered in 2008

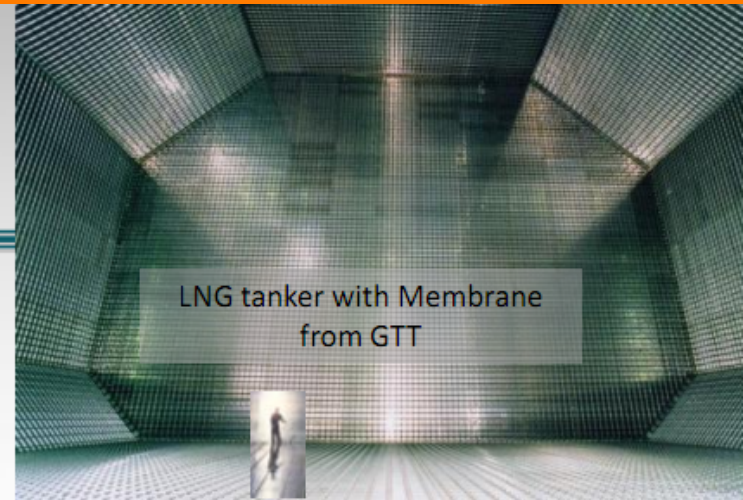

LNG tanker with Membrane from GTT

Vendors: Gaz Transport & Technigaz (GTT)
Ishikawajima-Harima Heavy Industries Co., Ltd. (IHI)

GTT Membrane Technology

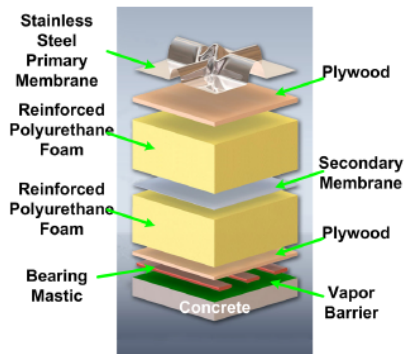

Nominal Panel Size
1m x 3m x 1.2 mm
thickness

IHI Membrane Technology

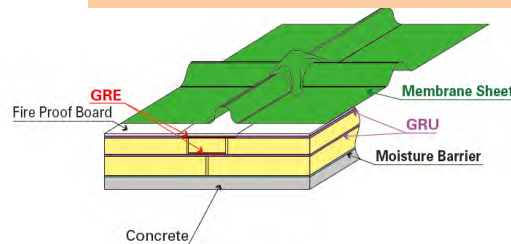

GRE: Glass Cloth Reinforced Epoxy
GRU: Glass Cloth Reinforced urethane

Nominal Panel Size
3m x 8m x 2 mm
thickness

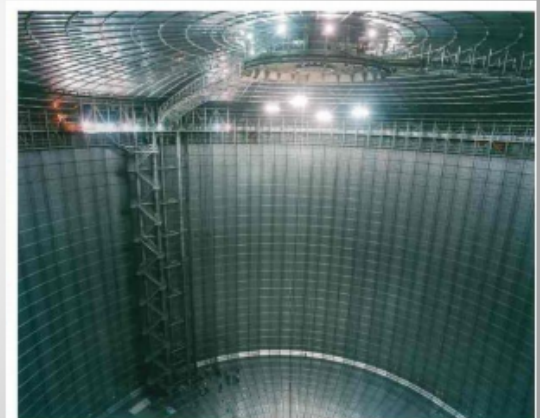

LNG Storage with Membrane from IHI

Photon Detection

- The 1.4 ms drift time of the electrons is very slow.
 - The beam spill is 10 μs long – gives t_0
 - For non-beam related physics the interaction time is unknown. **Use the light to determine the event time.**
- A lot of light, but complicated structure
 - Scintillation and Cherenkov radiation – 5 times more scintillation light
 - 23% of the scintillation light is prompt ($\sim 6\text{ns}$)
 - 77% of the light is late ($\sim 1.6 \mu\text{sec}$).
 - Prompt yield 33,000 128nm photons per MeV for a MIP
 - Scattering length is $\sim 95 \text{ cm}$
 - Present coverage is 0.4%

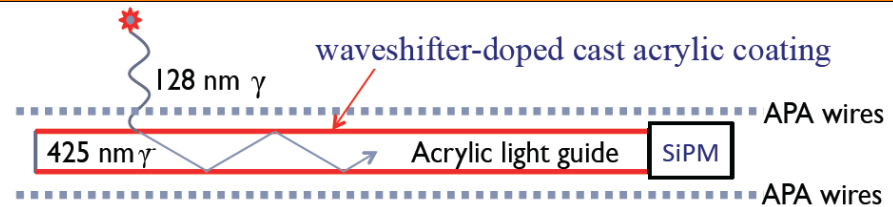

Reference Design – wave-length shifter on surface

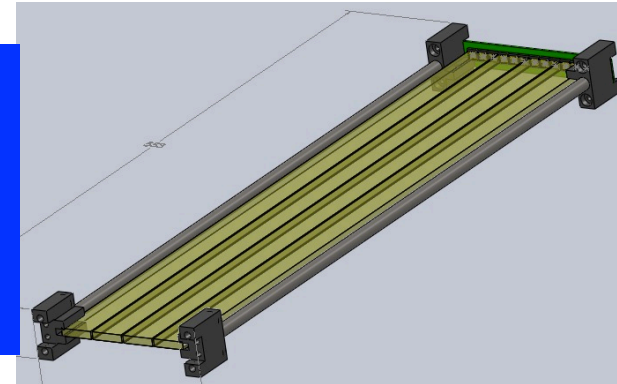

Alternate Design – doping of the bulk

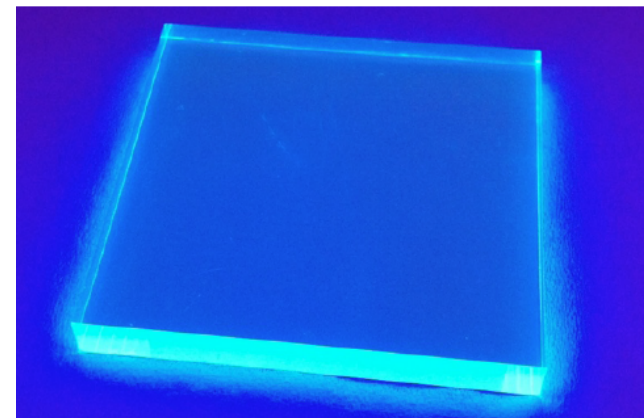

Photon Detection System is critical for low energy events

Atmospheric Neutrinos

- Largest L/E range of any neutrino source above muon production threshold
- Protons and low-energy charged pions are visible in liquid argon TPCs – better pointing resolution than water Cherenkov detectors at low-to-moderate neutrino energies
- Can separate muon neutrino and anti-neutrino events by searching for muon capture (75% probability for μ^-), final state proton vs. neutron for quasi-elastic neutrino interactions
- These features give the LBNE far detector sensitivity to the neutrino mass hierarchy

Atmospheric Neutrinos Neutrino Mass Hierarchy

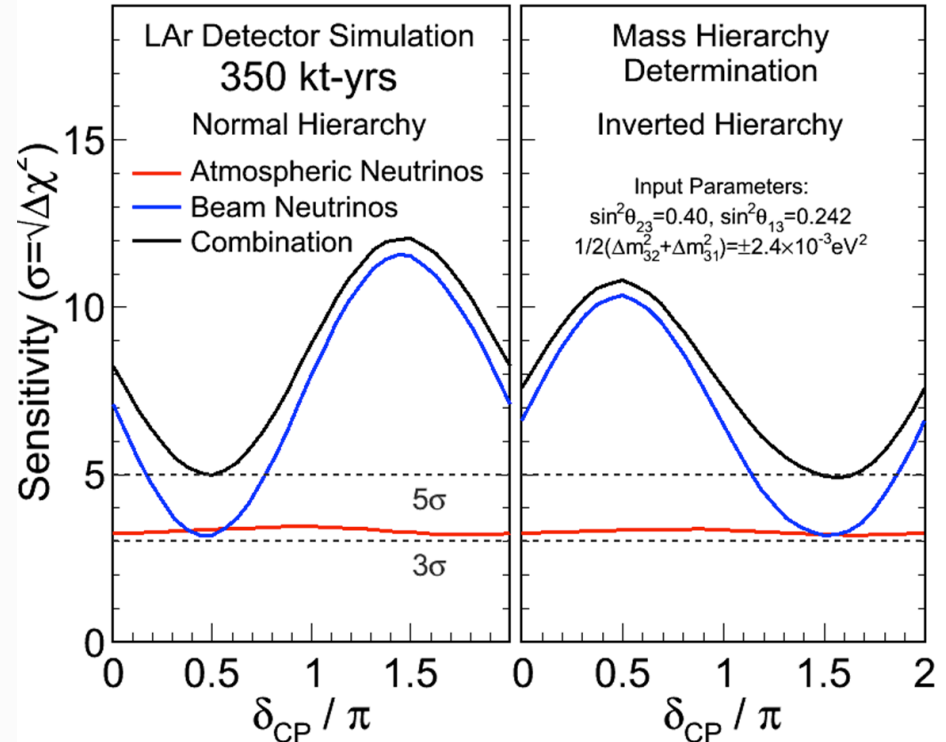
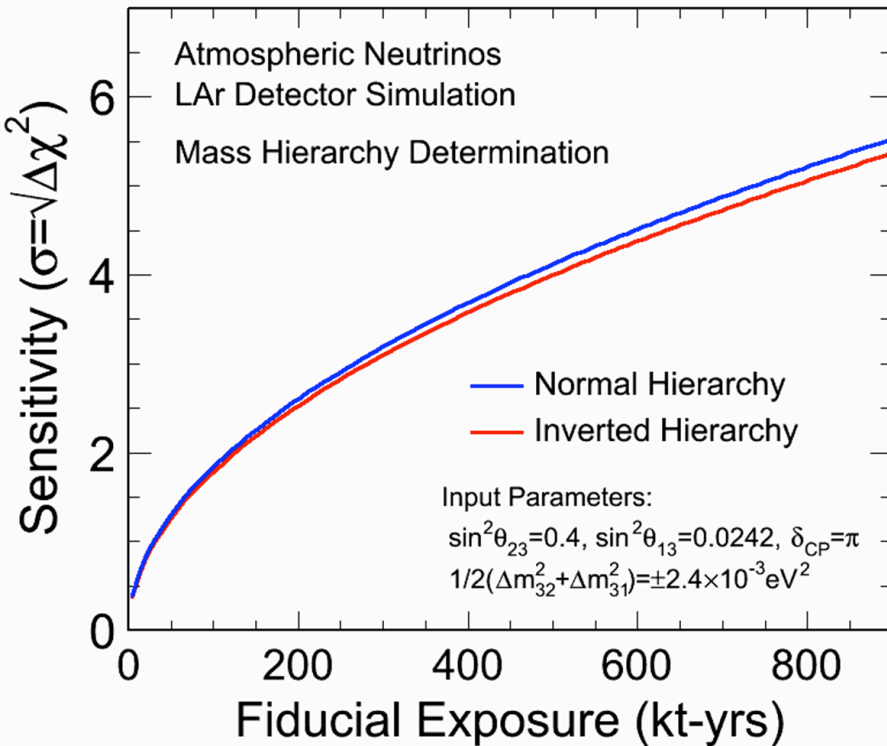

- Atmospheric neutrinos provide independent test in a different system with the same detector systematics
- Beam and atmospheric neutrinos combined give excellent sensitivity

Nucleon Decay

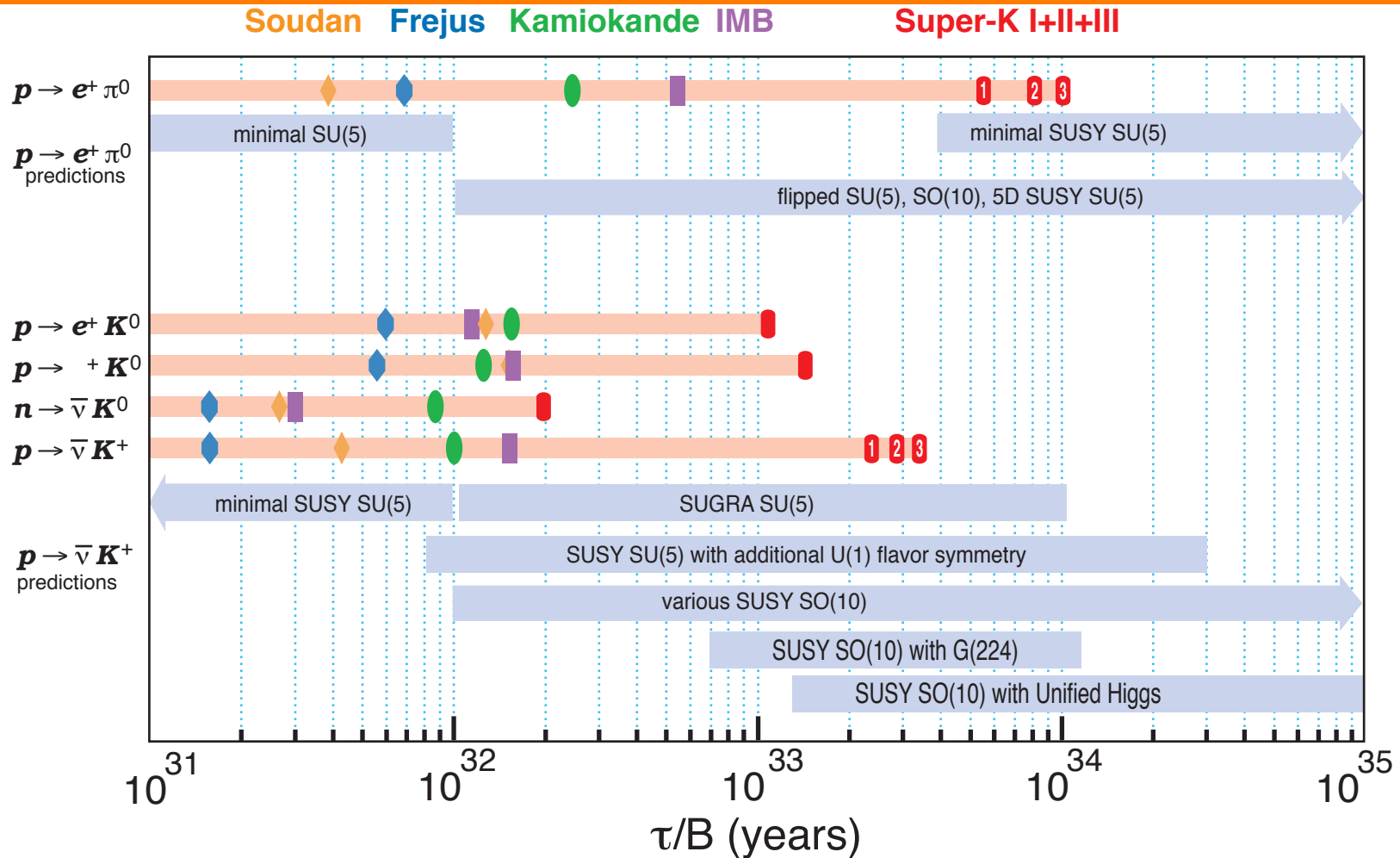
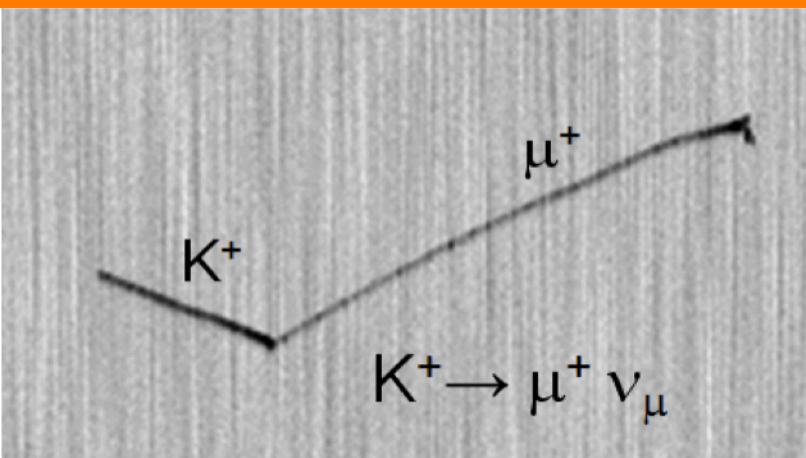

Figure from Kearns

Predicted by models beyond the Standard Model – Grand Unified Theories, Supersymmetry

Liquid Argon TPCs Complementary to Water Cherenkov Detectors



Icarus simulation

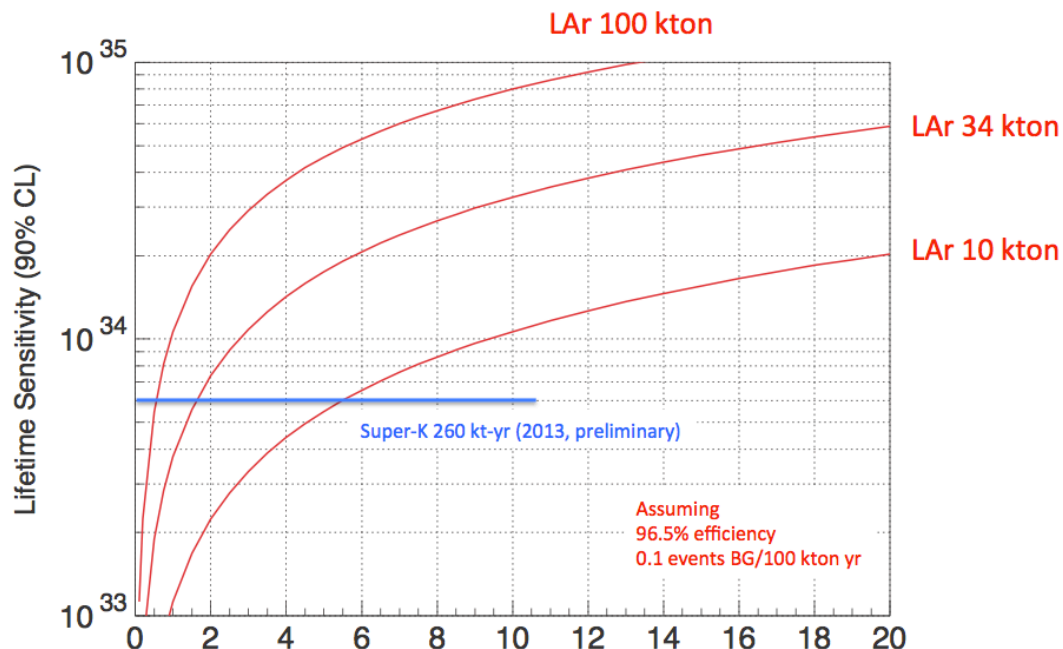

Decay Mode	Water Cherenkov		Liquid Argon TPC	
	Efficiency	Background	Efficiency	Background
$p \rightarrow \nu K^+$	19%	4	97%	1
$p \rightarrow \mu^+ K^0$	10%	8	47%	< 2
$p \rightarrow \mu^- \pi^+ K^+$			97%	1
$n \rightarrow e^- K^+$	10%	3	96%	< 2
$n \rightarrow e^+ \pi^-$	19%	2	44%	0.8

- Smaller exposure, so LAr shines with high efficiency modes

Supernova Neutrinos

- Supernova bursts in our galaxy are a fantastic source of neutrinos
- Significant fluxes in < 10 seconds
- Matter effects unachievable from other sources
- Argon uniquely sensitive to CC electron neutrino interactions – complementary to water Cherenkov detectors sensitive to CC electron anti-neutrino interactions

Reaction Type	Events / 10 kton	(at 10 kpc)
(CC) $\nu_e + {}^{40}\text{Ar} \rightarrow e^- + {}^{40}\text{K}^*$	~ 700 [1]	[1] K. Scholberg [2] A. Hayes
(CC) $\bar{\nu}_e + {}^{40}\text{Ar} \rightarrow e^+ + {}^{40}\text{Cl}^*$	~ 60 [1]	
(ES) $\nu_x + e^- \rightarrow \nu_x + e^-$	~ 85 [1]	
(NC) $\nu_x + {}^{40}\text{Ar} \rightarrow \nu_x + {}^{40}\text{Ar}^*$	~ 90 [2]	

Neutrino Mass Hierarchy Information

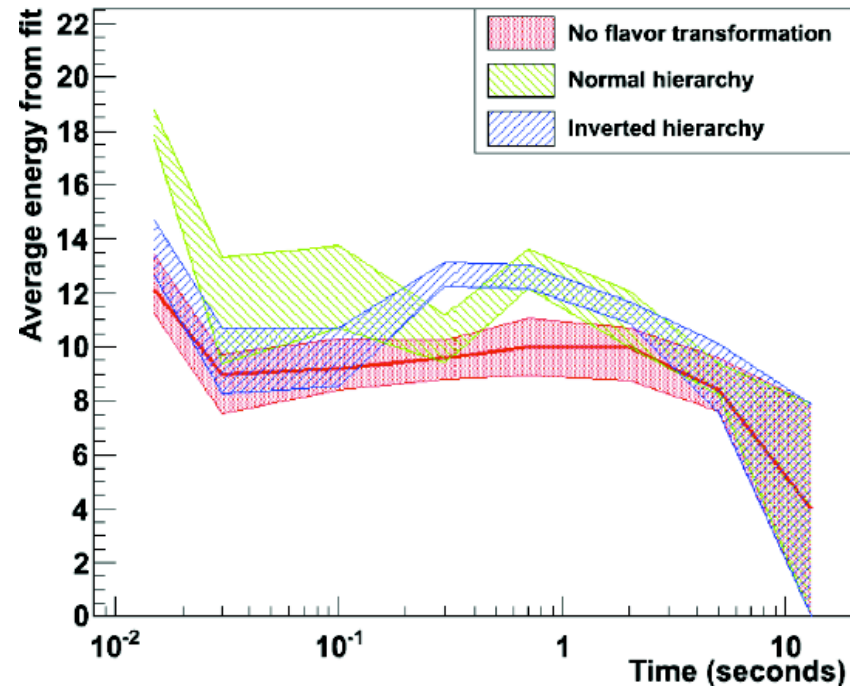
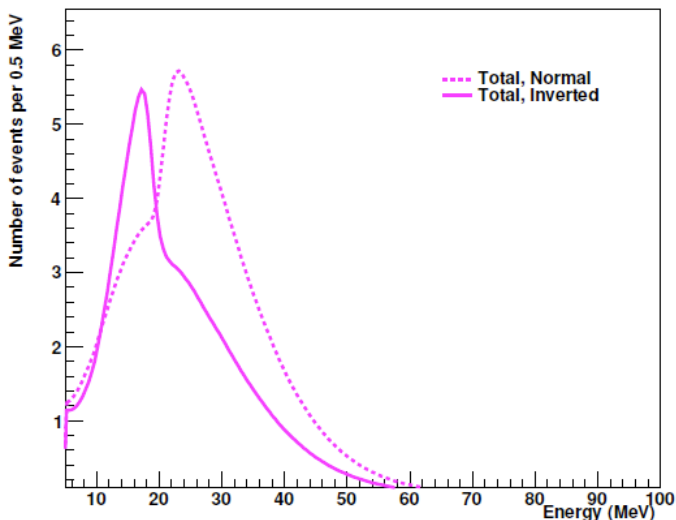
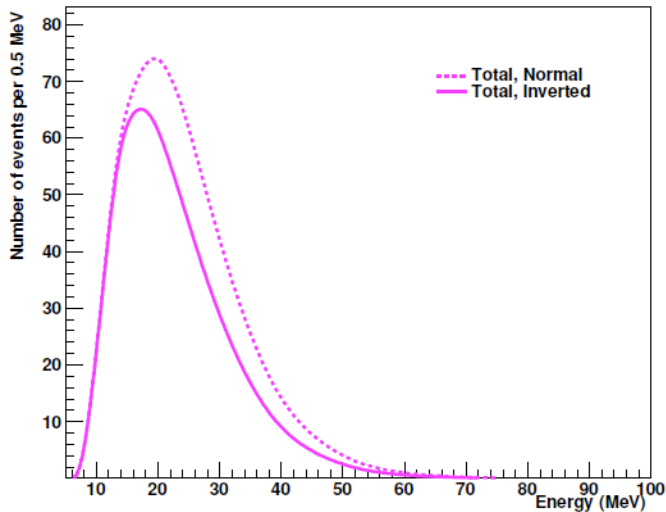

- Left: Event rates for a 100kt water Cherenkov detector (upper) and 17kt (sorry) liquid argon TPC (lower) (model from Duan and Friedland: Phys. Rev. Lett., 106:091101, 2011)
- Upper: Average electron neutrino energy as a function of time for different mass hierarchy assumptions with 34 kt (model from Keil, Raffelt, and Janka: Astrophys. J., 590:971-991, 2003)

Conclusions

- The Long-Baseline Neutrino Experiment consists of an exciting and diverse physics program enabled by a strong and developing international partnership
- The beam neutrino physics probes the neutrino mass hierarchy, leptonic CP violation, non-standard neutrino interactions among others
- The highly capable near neutrino detector enables the long-baseline neutrino oscillation program as well as a significant high precision neutrino interaction program
- The far detector – besides its duties as a far detector for the beam physics program – enables searches for baryon number violation, measurements of neutrinos from supernova bursts, and measurements of atmospheric neutrinos
- LBNE has received approval to begin this program

Backup

Baseline Optimization

Mass Hierarchy Determination

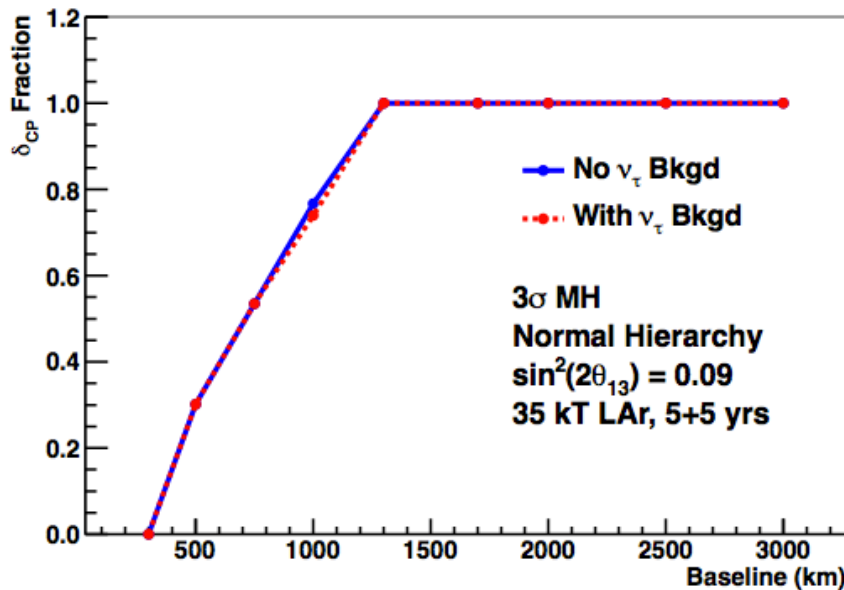

CP Phase Measurement

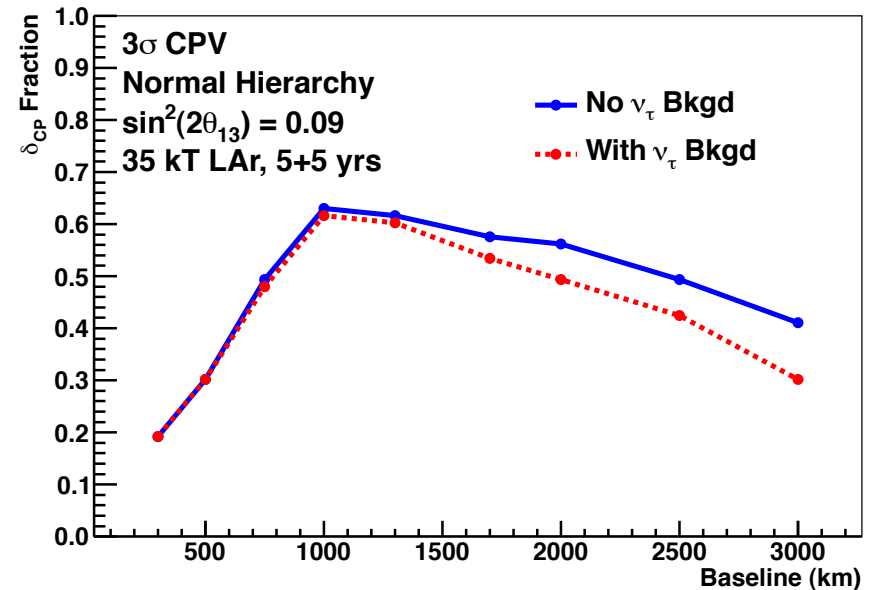

- Fraction of δ_{CP} values for a 3σ result
- Assumptions:
 - Normal hierarchy, $\sin^2 2\theta_{13} = 0.09$
 - 120 GeV, 700kW beam, 5+5 years of running (5 neutrino, 5 anti-neutrino), 35-kt LAr TPC
- 1300km baseline economical solution for a comprehensive neutrino oscillation program

Muon Neutrino Disappearance

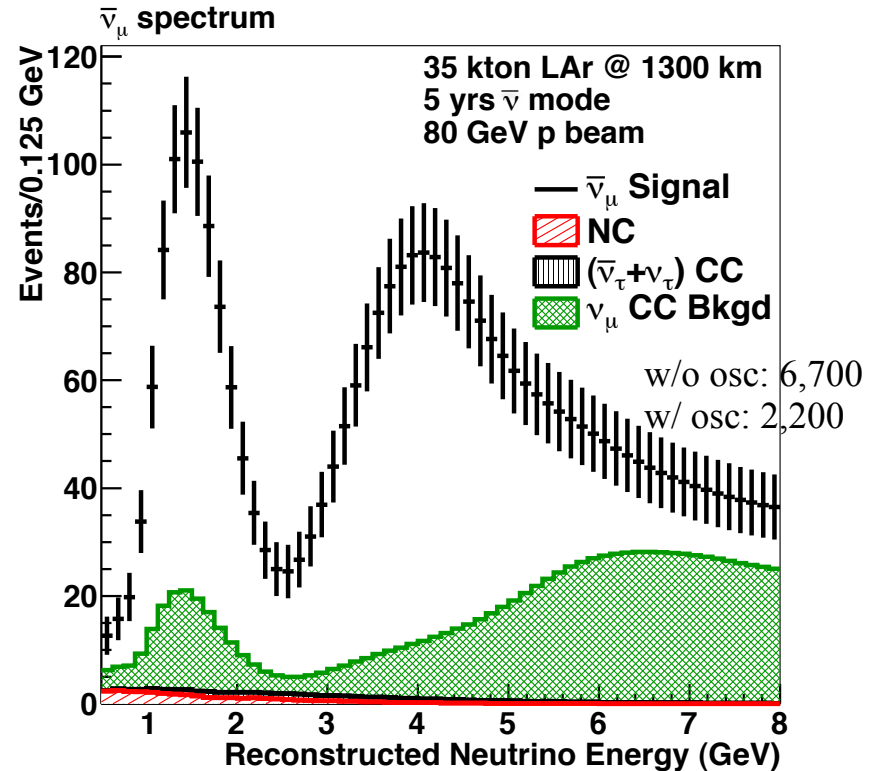
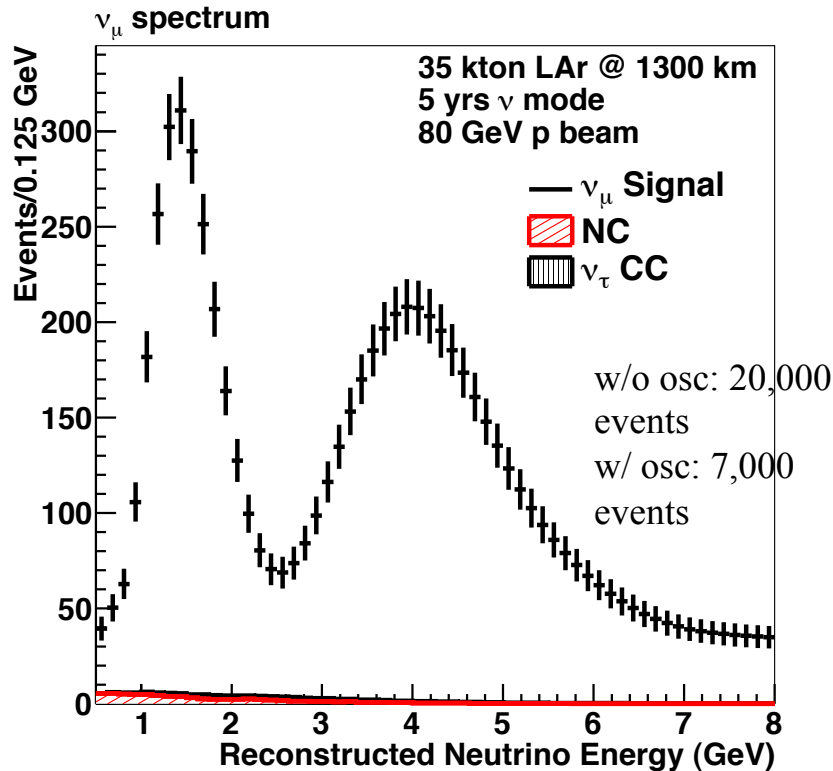

- 35-kt LAr TPC, 80 GeV, 700kW proton beam
- Tau neutrino background accounted for

Measurements of muons post-absorber

Ionization Chambers:

spill-by-spill beam profile

Cherenkov Detectors:

measure all muons above a
variable threshold

constrains muon spectrum
(correlated with E_ν)

Michel Decay Detectors:

measure muons that stop at
a given depth in material
constrains muon spectrum
may give absolute flux
constraint

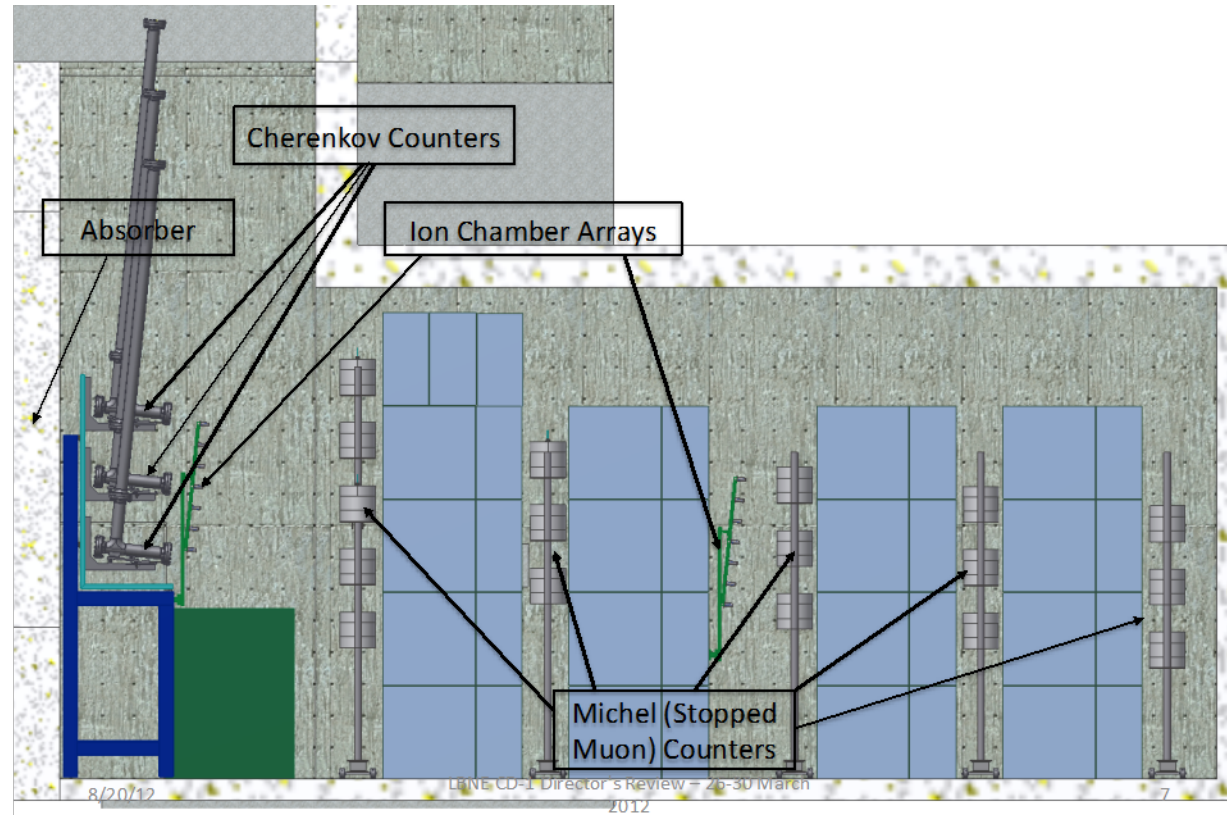

Includes planning measurements of hadron production
in external beamlines on materials from
which the target and horns are composed

Correlation between muon and neutrino energies

- Muons and neutrinos are anti-correlated in the two-body decays of pions and kaons
- Muons take most of the momentum in the decay
- For pions:
 - $E_\nu = (0-0.43)E_\pi$
 - $E_\mu = E_\pi - E_\nu = (0.57-1.0)E_\pi$

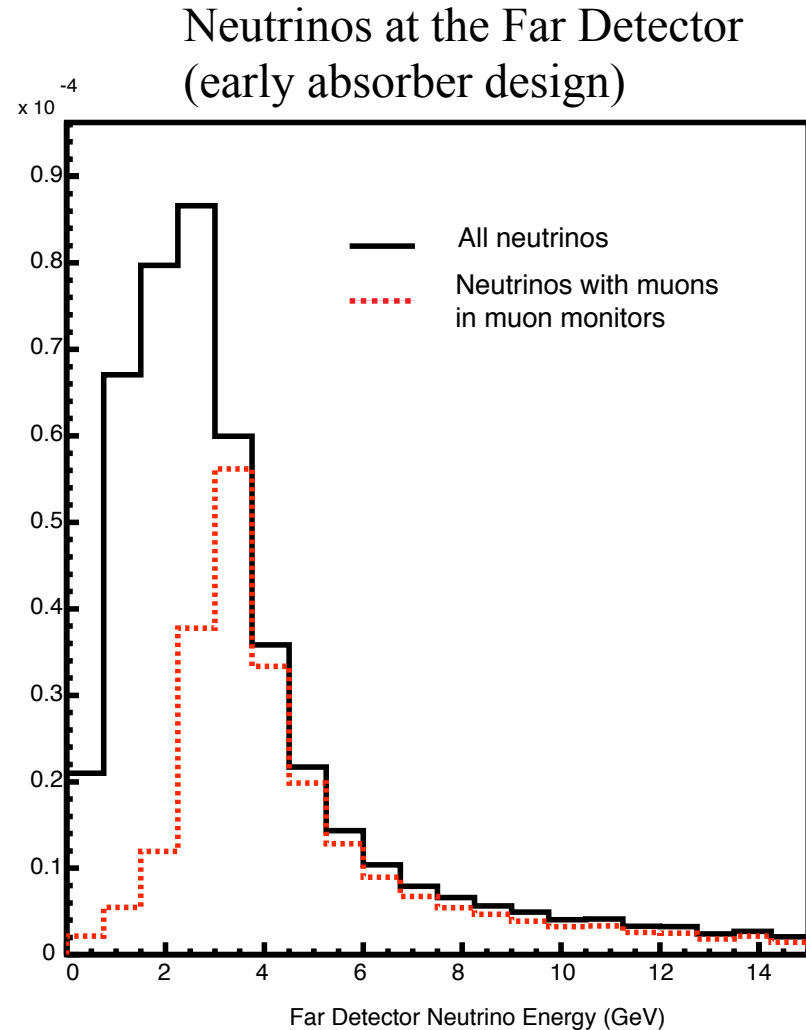

Absorber an Muon Alcove

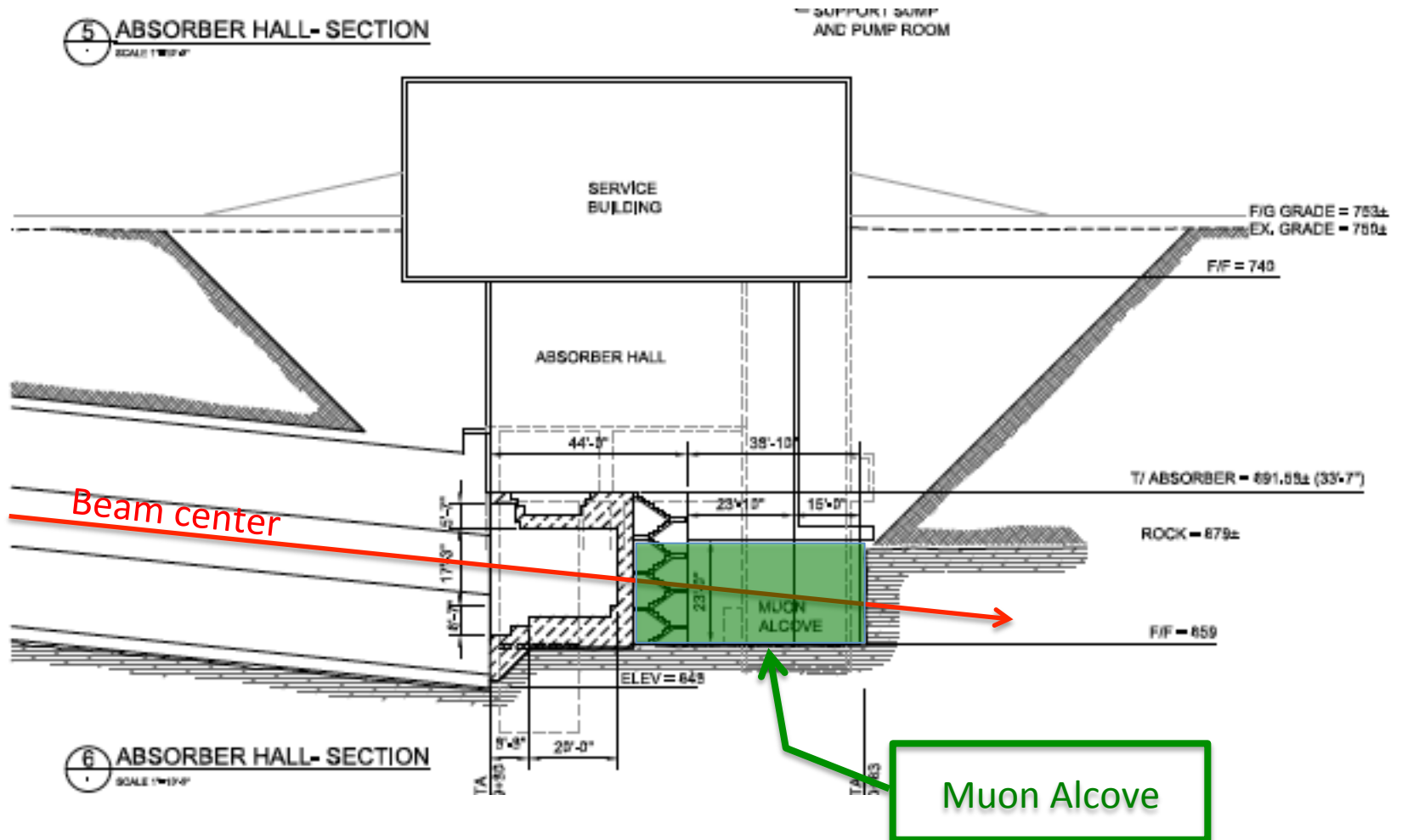

Absorber and Alcove Region

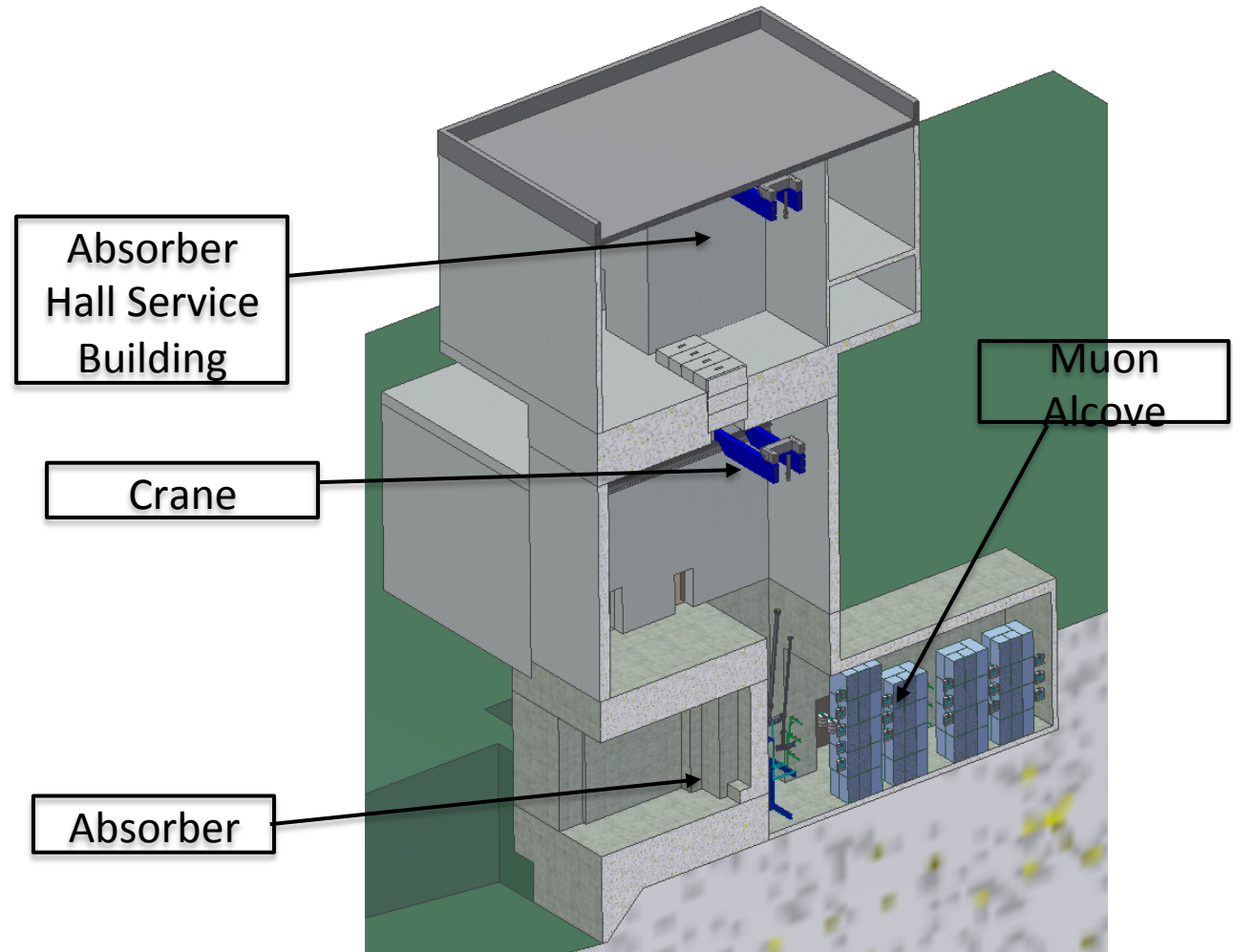

Threshold Cherenkov Detector

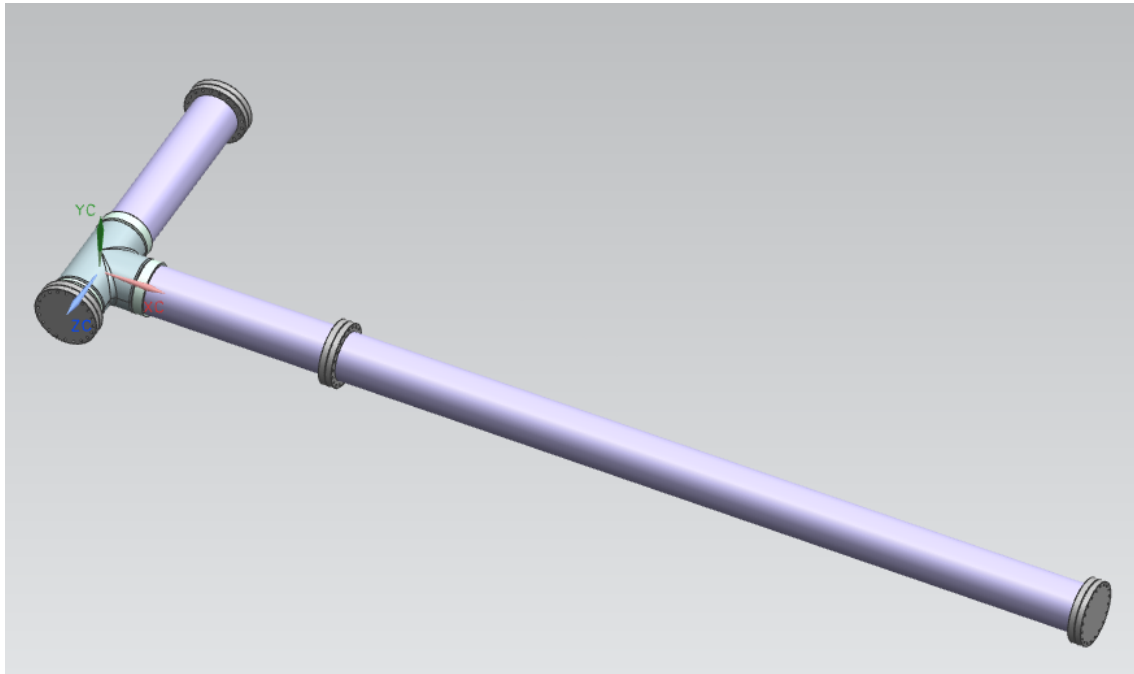

- Pressure varies from vacuum to ~ 20 atm
- Collect forward light from muons near Cherenkov threshold
- Flat mirror optics

Stopped muon detector

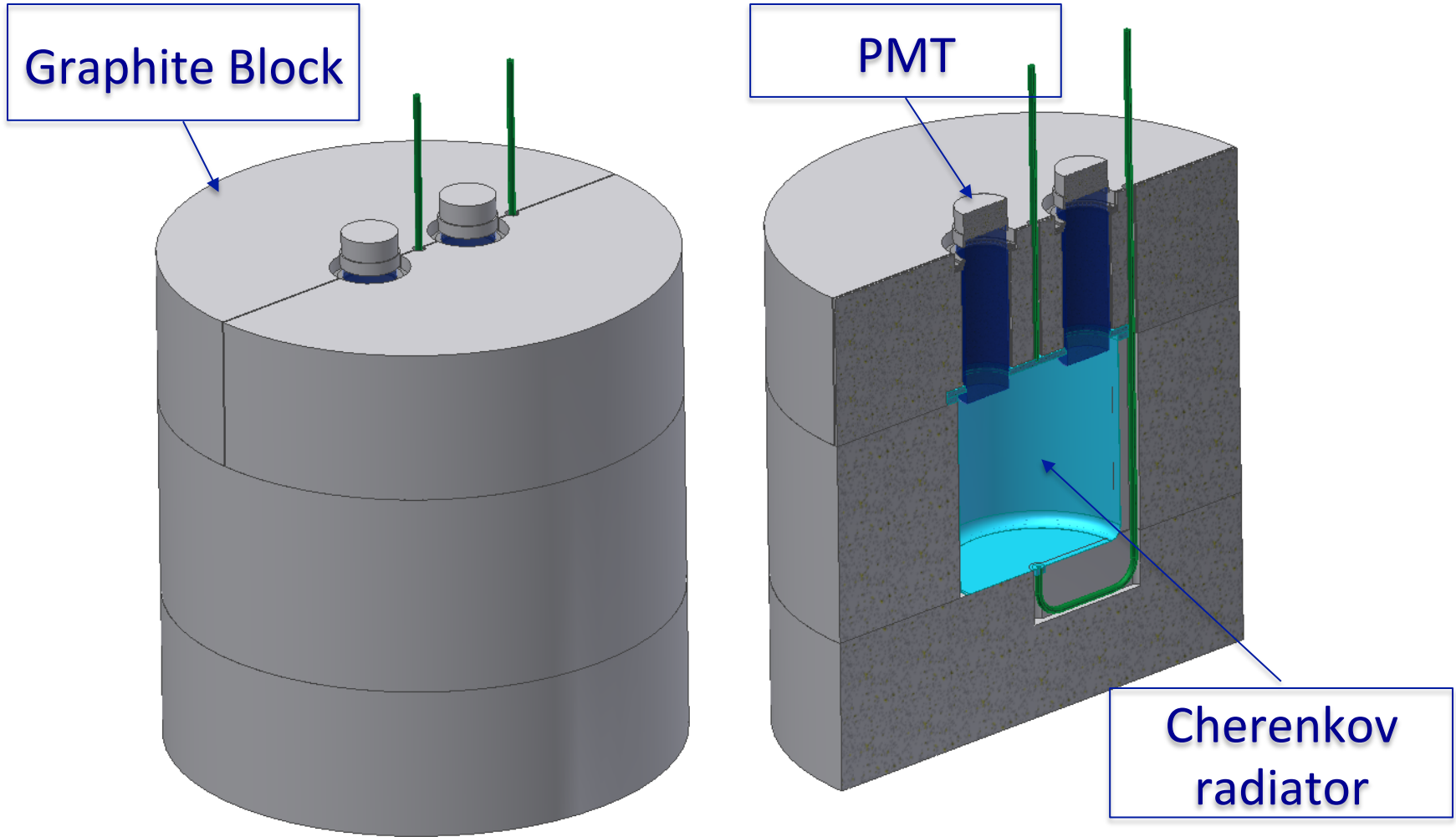

Measures decay of muons stopped in the radiator and decay of boron from muon capture

Prototyping Activities

Alcove 3

Deploy prototypes in the NuMI beamline

Alcove 2

Beam

DAQ Station

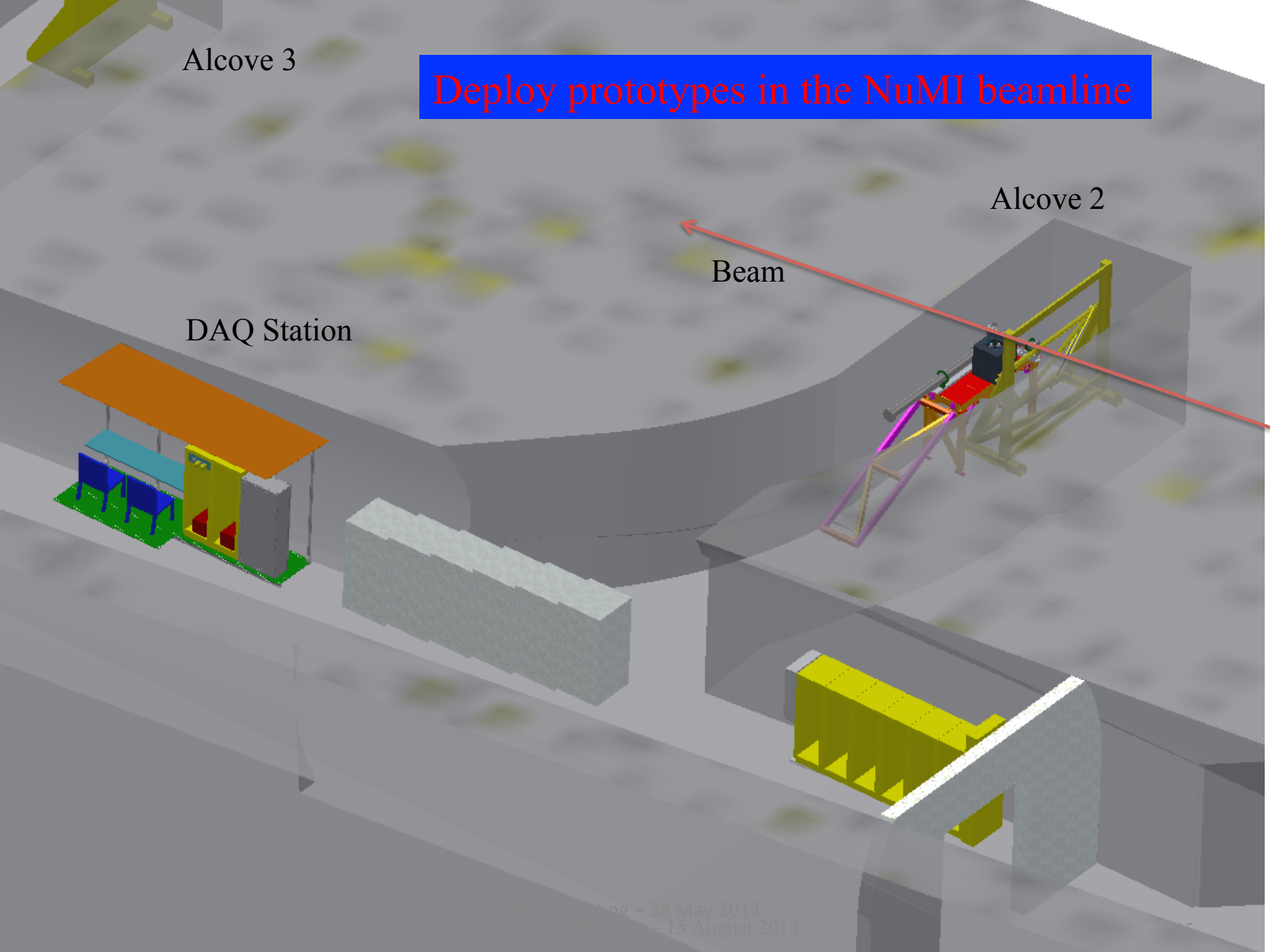
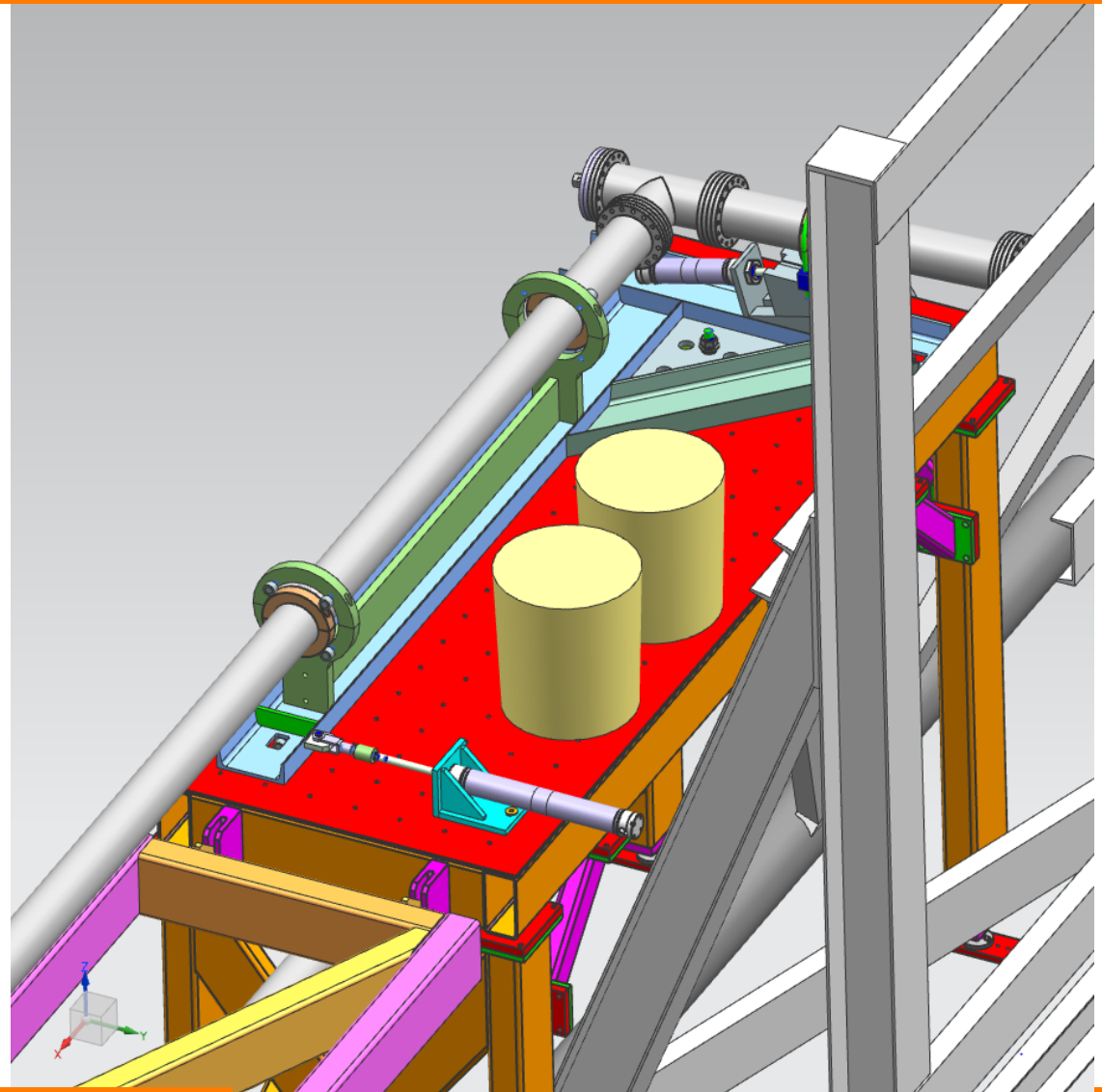

Table for All Prototypes

- During NuMI shutdown - install table for easy deployment of prototypes during brief subsequent shutdowns
- Install all required services
- NuMI beamline running imminent
- Some prototypes are ready for installation



Threshold Cherenkov Detector Prototype

Mirror Alignment in MI8

Laser

Laser alignment
lines

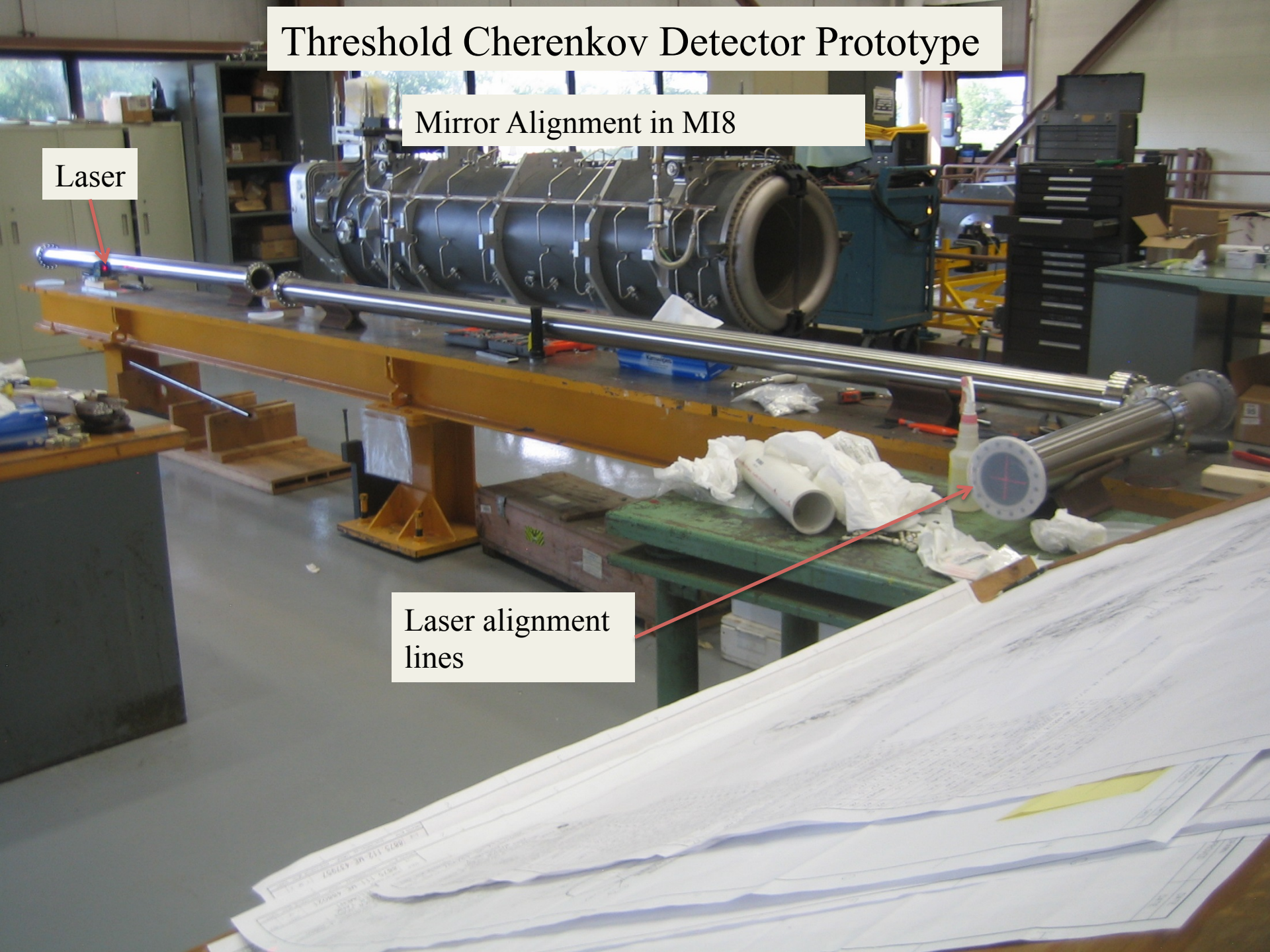

Mirror Installed in Tee

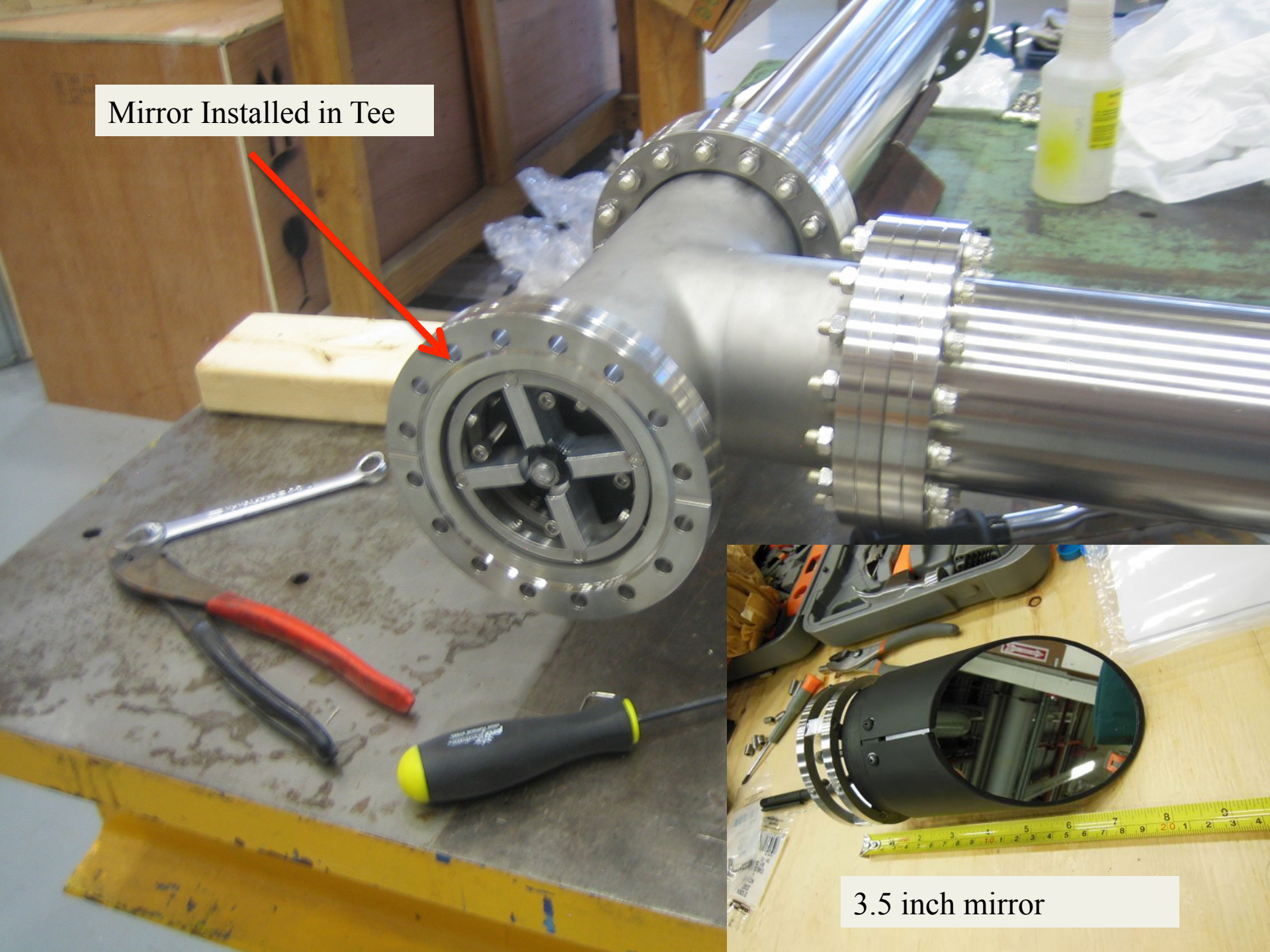

3.5 inch mirror

Sealed system being pumped down

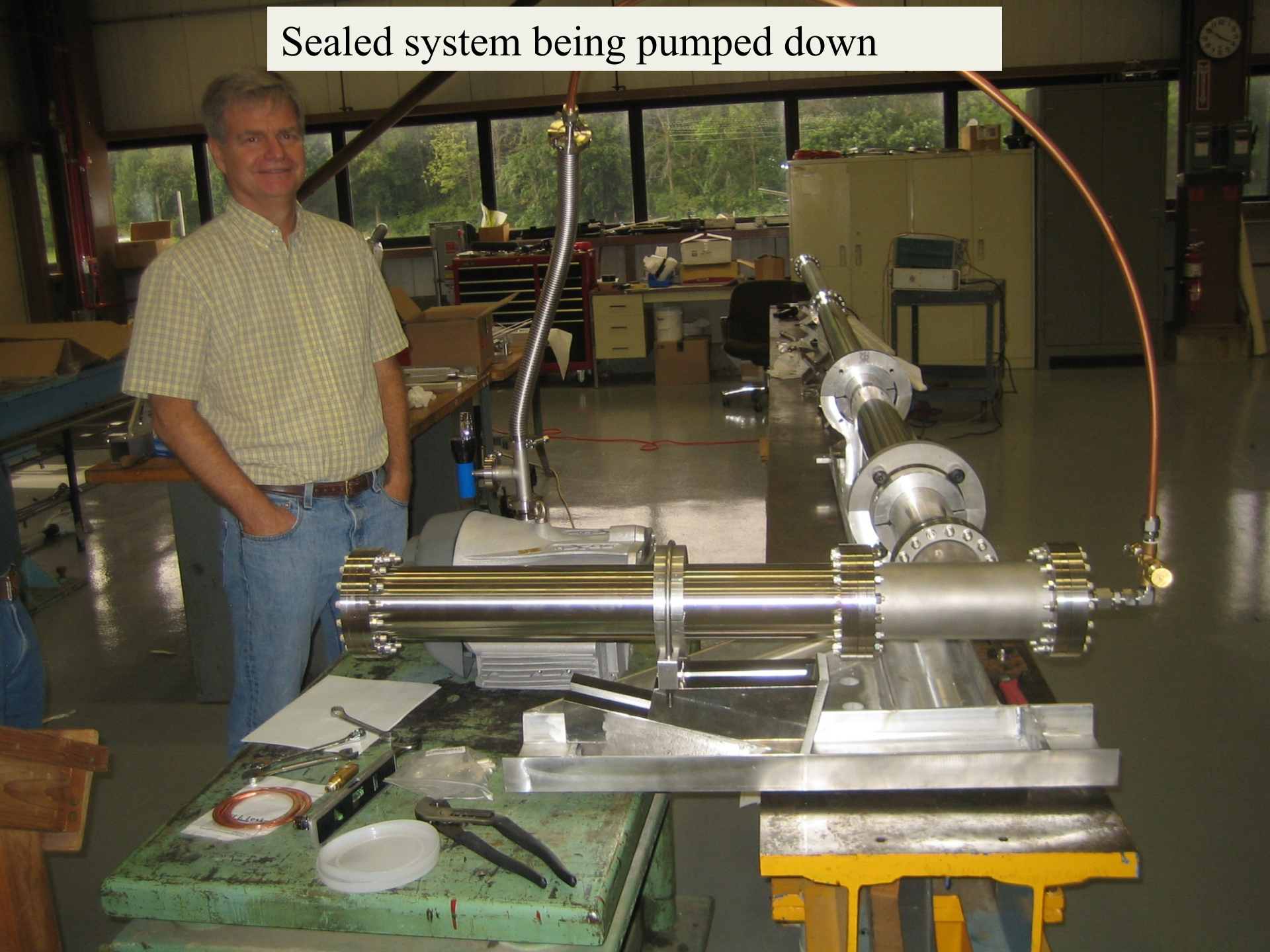



Strawtube Tracker

- Low density allows for electron sign discrimination
- Detailed absolute and relative flux measurements
 - low ν_0 method
 - neutrino-electron elastic scattering
 - inverse muon decay
 - low-momentum transfer quasi-elastic events on hydrogenic targets
- High-precision measurements of all important interaction modes for LBNE on argon
 - Quasi-elastic
 - Resonant production – including strange production
 - Deep Inelastic Scattering
- Detailed measurements of various nuclear effects – especially those that impact neutrino energy reconstruction in the far detector
- Enables high-precision prediction of events in the far site for any neutrino oscillation paradigm

Strawtube Tracker

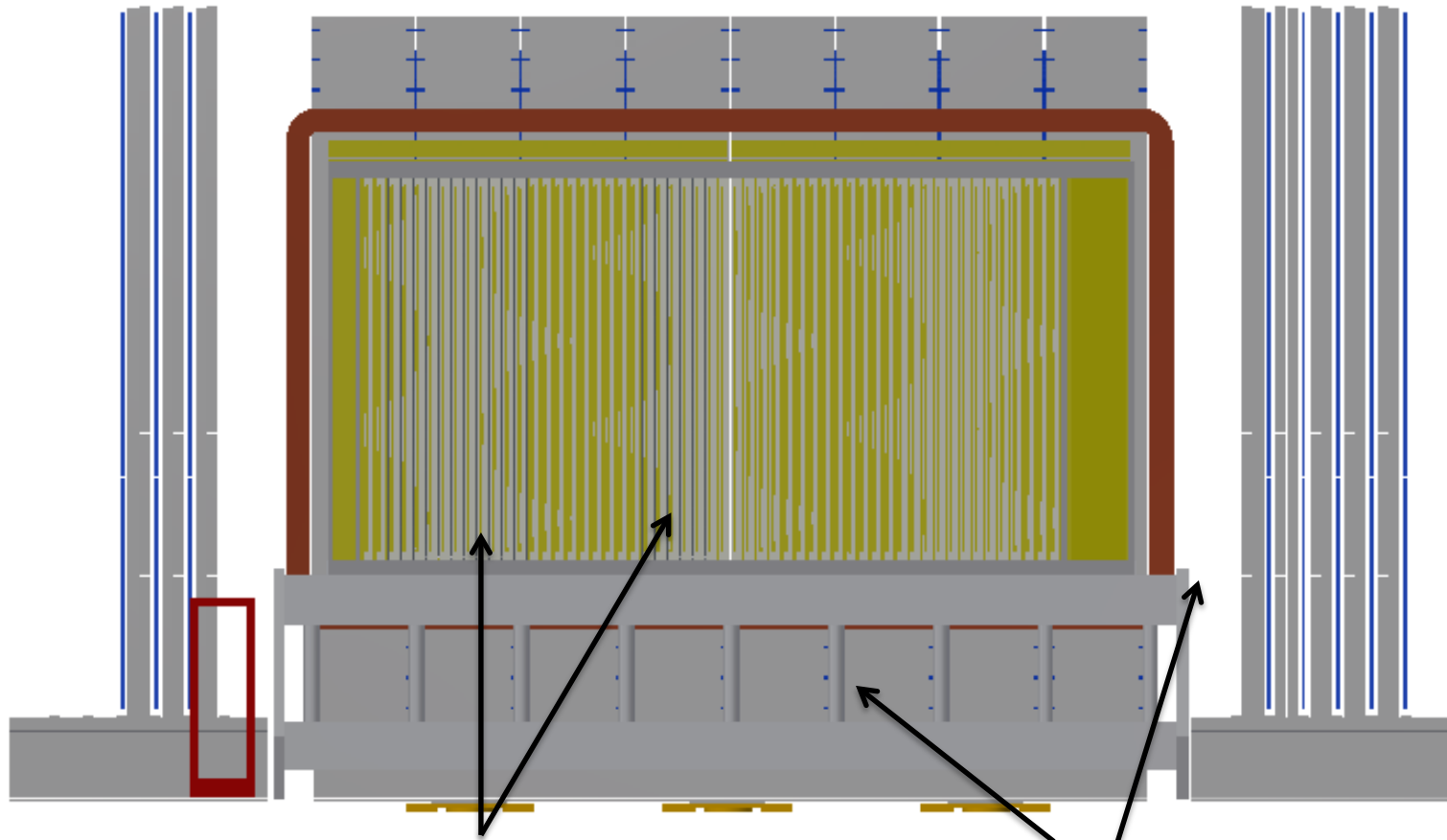

Argon gas and heavy/light water targets

Average density $\sim 0.1 \text{ g/cm}^3$

UA1-style dipole magnet – 0.4 T

Muon identifier – also interleaved in magnet

Barrel ECal Side Module

3.96m Y direction, 3.71m Z direction

8 layers of 7mm thick lead, 10mm thick scintillator (4 total modules)

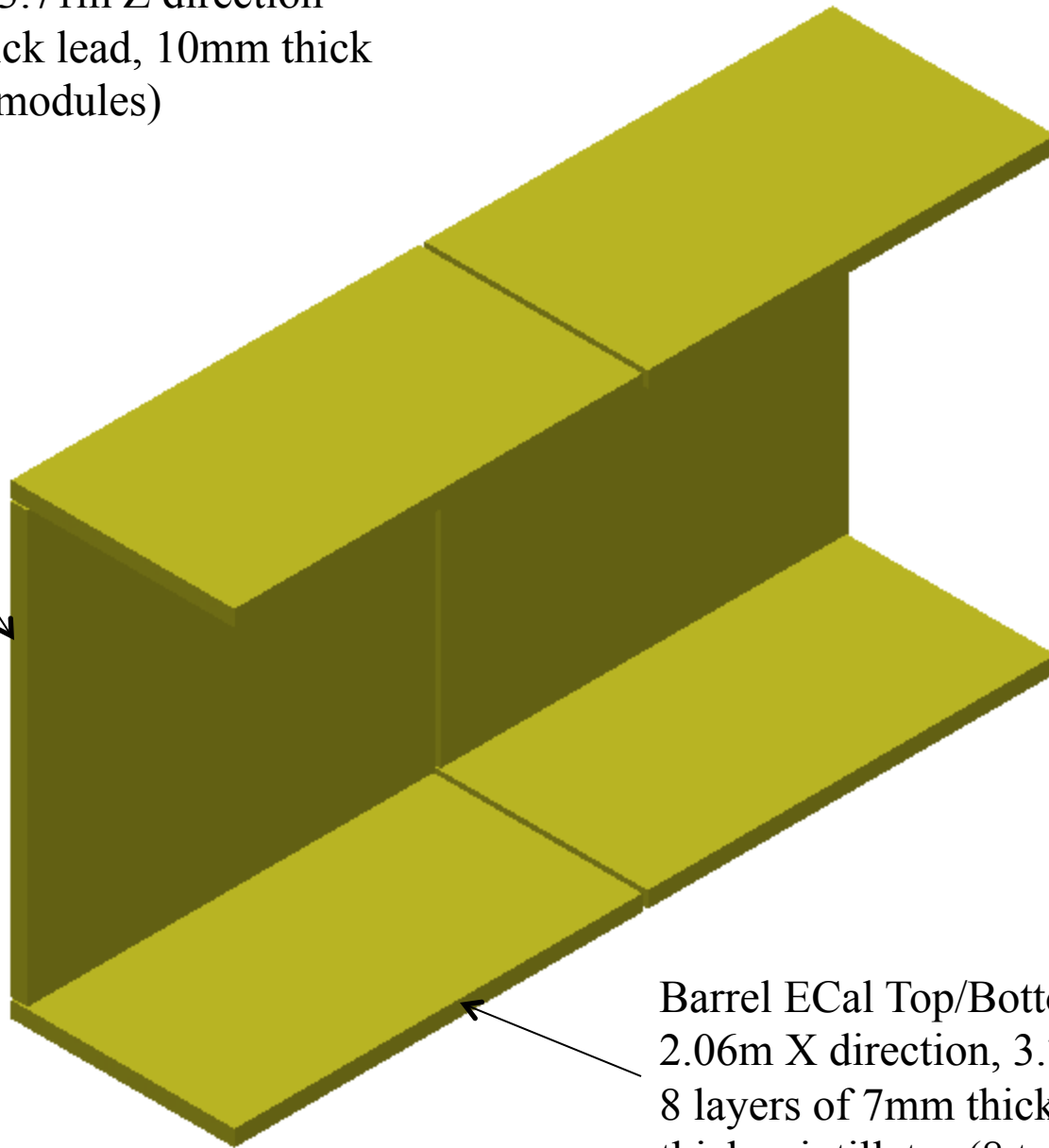

4π coverage gives excellent neutral pion identification and containment

Barrel ECal Top/Bottom Module
2.06m X direction, 3.71m Z direction
8 layers of 7mm thick lead, 10mm thick scintillator (8 total modules)

Near Detector Physics List

- Weak mixing angle
- Strangeness content of the nucleon
- Nucleon structure
- Search for heavy neutrinos
- Search for high Δm^2 neutrino oscillations
- Light dark matter searches
- Many others, see the whitepaper

Alternative Design – Liquid Argon TPC

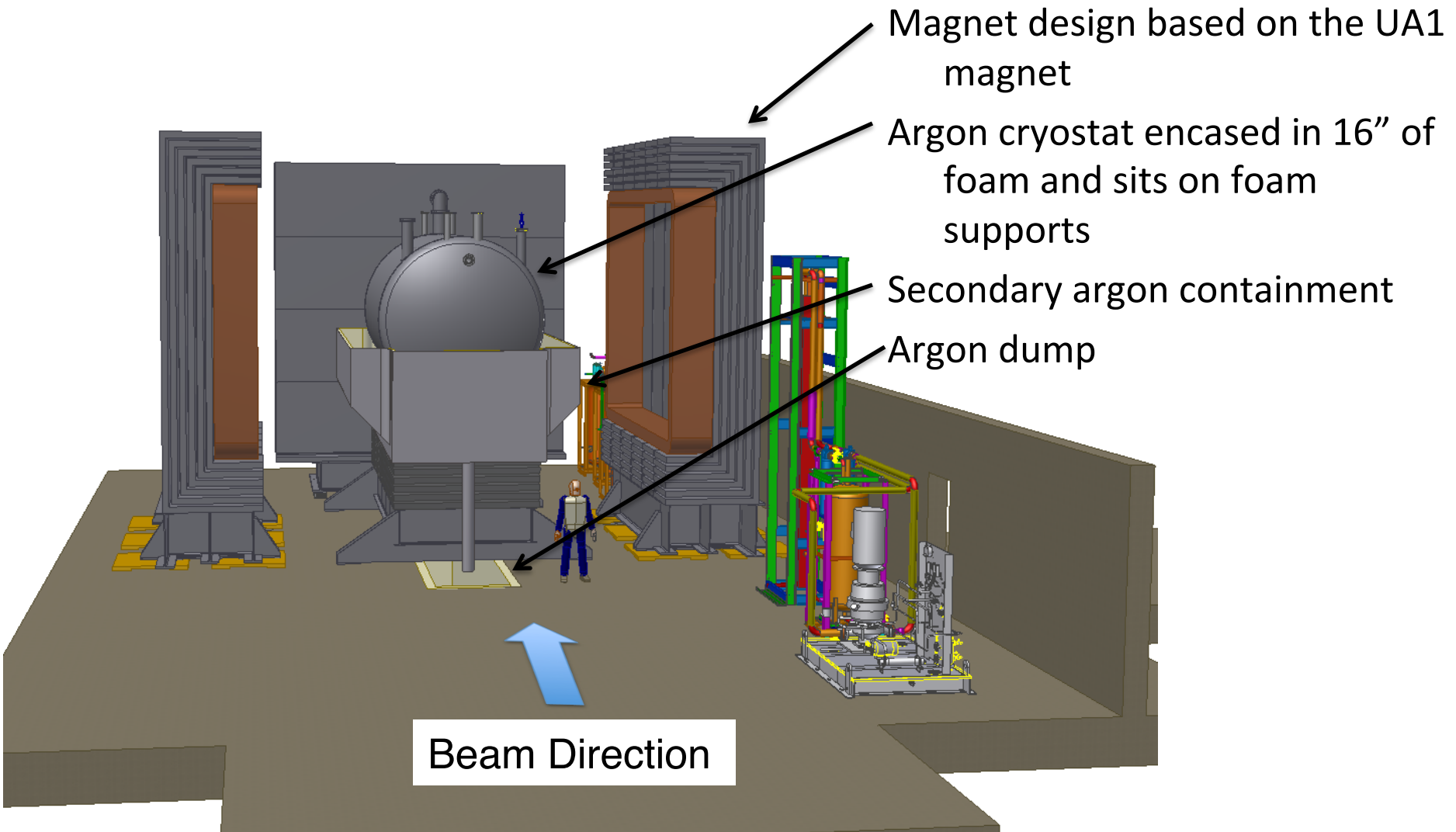

Near Liquid Argon TPC

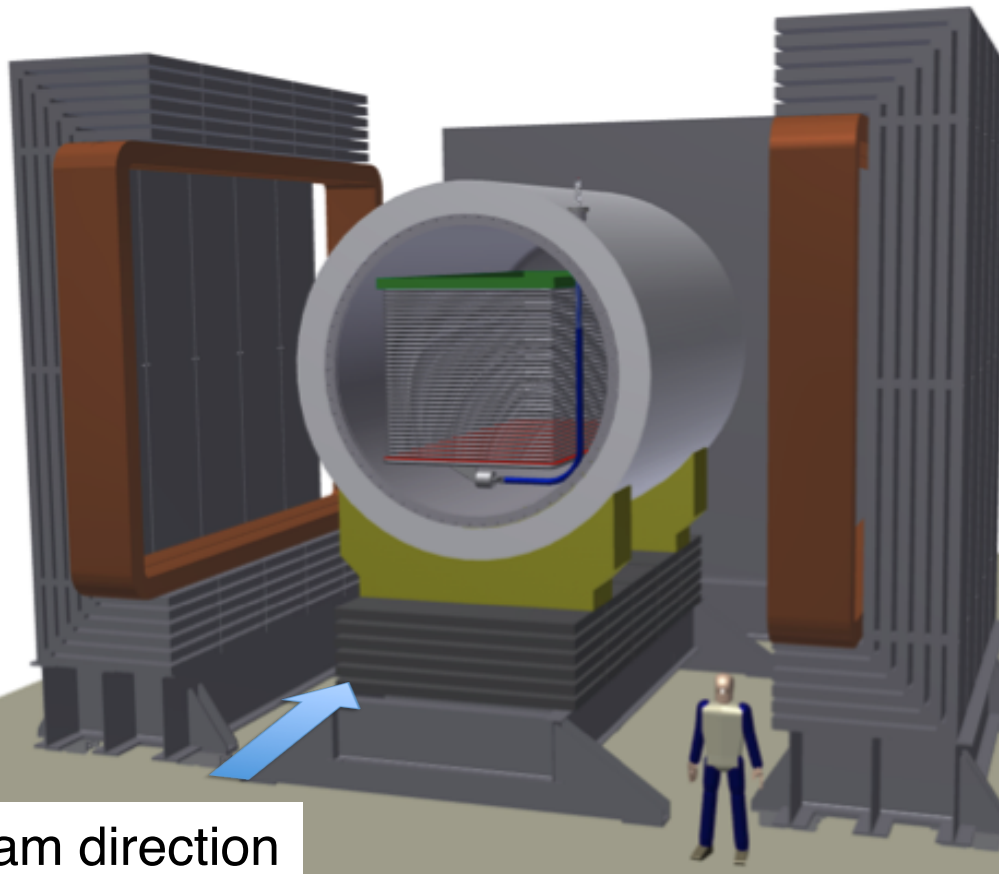

Beam direction

Based on MicroBooNE design
4.0m x 1.8m x 1.8m active
volume – 18 tons of liquid
argon

Tracks charged particles

Electromagnetic calorimetry

0.4 Tesla field

Sign of muons, momentum for
long tracks

Downstream/side detectors in
steel layers for muon/pion
separation

Far Detector Layout

- 10 kt fiducial mass Liquid Argon (LAr) detector located on the surface in Lead, SD (two 5 (9.4) kt Fiducial Mass (Total Mass) modules)
- Detector designed to detect accelerator neutrinos
- Anode and Cathode Plan Assemblies (APAs, CPAs)

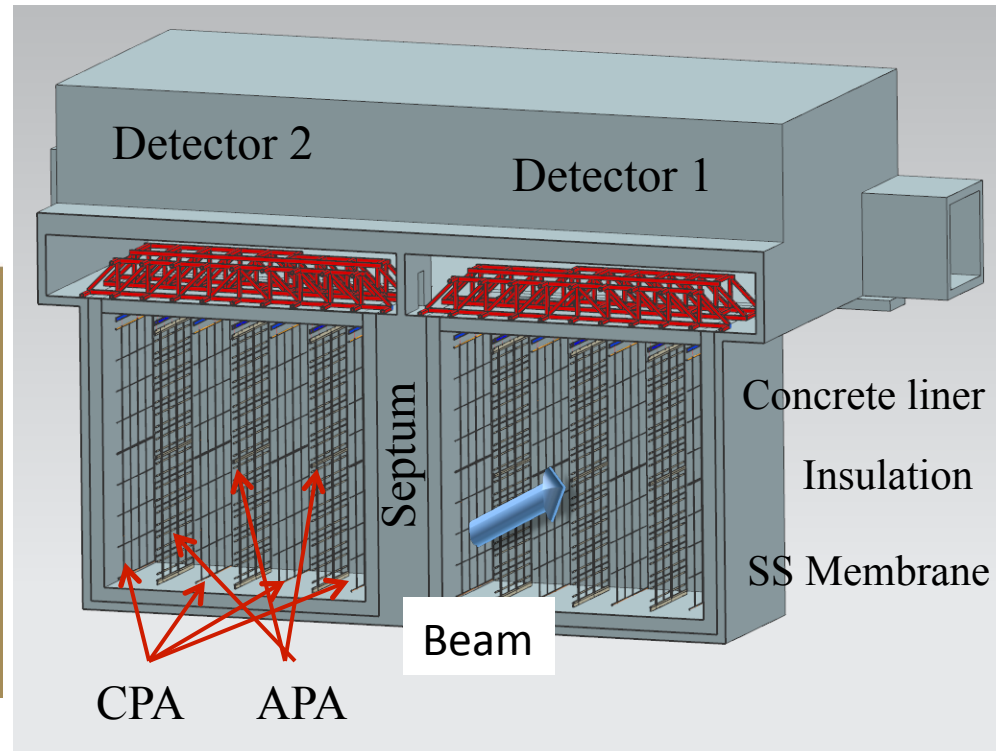
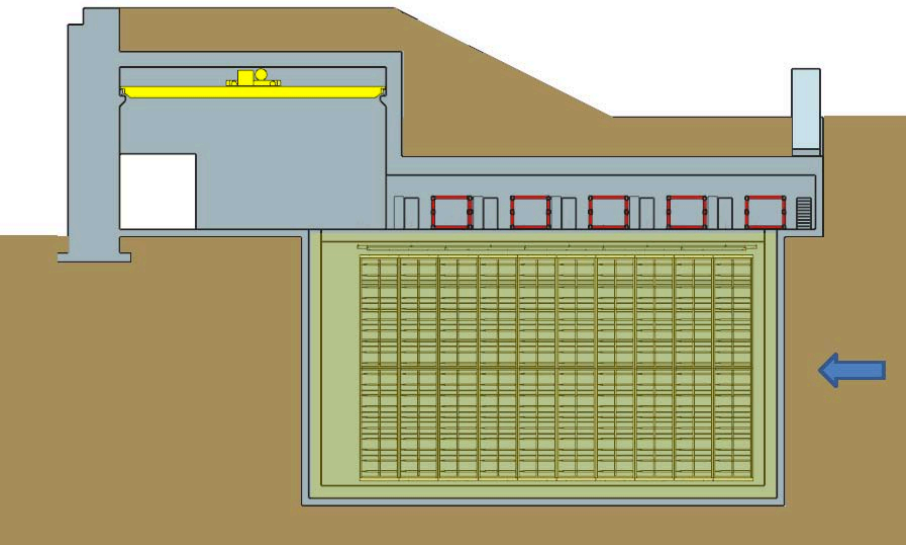

LBNE Reconfiguration

Complete Design Independently Reviewed and Found to be Sound

Issued April 23, 2012



Final Report

Director's Independent
Design and CD-1 Readiness Review
of the LBNE Project

March 26-30, 2012

Director's Independent Conceptual Design and CD-1 Readiness Review
March 26-30, 2012

Issued April 23, 2012

Executive Summary

This Director's review was designed to elicit the assembled committee's opinion on two primary questions. The first focus of the review was to perform an independent Conceptual Design review of the LBNE project to verify that the design is technically adequate, and should achieve the Project's scientific goals. The second focus was to perform a CD-1 Readiness review, with a focus on the project's cost, schedule, management, and ES&H.

The committee finds that the Conceptual Design for the LBNE project is sound, and should achieve the Project's scientific goals. Our determination is that the level of technical detail across the entire breadth of the LBNE project is sufficient to address the question of overall capability to achieve the scientific goals, as appropriate for this stage of the project. There are a number of components of the project that have advanced well beyond the conceptual stage.

The committee is confident that the LBNE project can be ready for a CD-1 review on the time scale given to the committee, the summer of 2012, if issues related to the funding profile and the resulting schedule are resolved. The management systems and documentation for the project are appropriate for a CD-1 review.

However ...

- Last year US funding agency (DOE) asked us to stage LBNE construction and gave us a budget of \$867M for the first phase
 - They also encouraged us to develop new partnerships to maximize the scope of the first stage.
- We chose to proceed with emphasis on the most important aspects of the experiment: 1300 km baseline and the full capability beam
 - With just the DOE budget, the far detector would be 10 kt LAr TPC at the surface and there would be no near neutrino measurements.
- An external review panel recommended this phase 1 configuration.
- DOE approved “CD-1” in December 2012 for this phase-1 scope.
- *Our plan continues to be to build the full scope originally planned, and are working with domestic and international partners to make the first phase as close as possible to the original goal.*

DOE CD-1 Approval Document

lbne-doc-6681

Critical Decision 1
Approve Alternative Selection and Cost Range
of the
Long Baseline Neutrino Experiment (LBNE) Project
(Line Item Project 11-SC-40)
at the
Fermi National Accelerator Laboratory and
Sanford Underground Research Facility
Office of High Energy Physics
Office of Science

Purpose

The purpose of this paper is to document the review and approval by the DOE Office of Science Energy Systems Acquisition Advisory Board-equivalent for Critical Decision 1 (CD-1) "Approve Alternative Selection and Cost Range" for the Long Baseline Neutrino Experiment (LBNE) Project at the Fermi National Accelerator Laboratory (Fermilab) and Homestake Mine

Critical Decision 1, Approve Alternative Selection and Cost Range
for the LBNE Project

Approval

Based on the information presented in this document and at the ESAAB review, I approve Critical Decision 1, Approve Alternative Selection and Cost Range for the Long Baseline Neutrino (LBNE) Project.

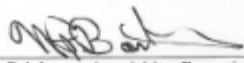
William Brinkman, Acquisition Executive
Director, Office of Science

12/10/12
Date

Tailoring of the scope definition prior to CD-2 to enhance scientific capabilities may also be considered. The physics opportunities offered by the beam from Fermilab and the long baseline may attract the support of other agencies both domestic and international. Contributions from such other agencies offer alternative funding scenarios that could enhance the science capabilities of the Project. If additional domestic or international funding commitments are secured sufficiently prior to CD-2, the DOE LBNE Project baseline scope could be refined before CD-2 to include scope opportunities such as a Near Neutrino Detector complex at Fermilab or an underground location at SURF for the far detector.

the neutrino mass states, would not be obtained, compromising the ability to understand the matter-antimatter asymmetry and resulting dominance of matter in the universe.

To meet the scientific and technical objectives for the LBNE experiment, the following draft key performance parameters have been developed.

<http://lbne2-docdb.fnal.gov/cgi-bin/RetrieveFile?docid=6681;filename=LBNE%20CD-1%20appr.pdf>

LBNE Phase I Goal

- Together with additional partners, build:
 - Neutrino beam for 700 kW, upgradeable to 2.3 MW
 - Highly-capable near neutrino detector
 - >10 kt fiducial mass LAr far detector at
 - A baseline of 1300 km
 - A depth of 4300 m.w.e.
- The world-wide community can build upon the substantial investment planned by the US to make LBNE a world facility for neutrino physics, astrophysics, and searches for non-conservation of baryon number.

Engaging International Partners

- We are in discussion with a number of potential non-US partners, both physics groups and funding agencies, in:
 - Brazil
 - India
 - Italy
 - UK
- LBNE and LAGUNA-LBNO have established a working group to explore joining forces
- Italian ICARUS groups joined LBNE
- Brazilian groups joined LBNE
- We have initiated preliminary discussions with:
 - CERN
 - Dubna
- Engaging others potential partners:
 - Japan
 - China
 - Additional countries in the Americas, Asia and Europe
- Also exploring how to engage domestic US funding agencies beyond the DOE

Near Neutrino Detector

- Indian Institutions have proposed to build a near neutrino detector based on a strawtube tracker
- Moving forward in the context of a broader Indian Institutions-Fermilab Collaboration
- Nascent prototyping effort at Panjab University and IIT-Guwahati
- Significant LBNE intellectual partner
- This is one example giving us hope for an exciting phase I physics program

LBNE and IIFC-nuP Working Meeting

6-7 June 2013

 Fermilab

by Fermi Research Alliance
For U.S. Department of Energy



Xinchun Tian, K Naga Depthi, Christopher Mauger, Bindu Bambah, Roberto Petti, Amandeep Singh, Bipul Bhuyan, Anjan Giri
Brian Mercurio, Kuldeep Kaur, Rukmani Mohanta, Ashok Kumar, Ramesh Babu T, Venktesh Singh, Milind Diwan, Raj Gandhi
Sanjib Mishra, Bob Wilson, Sonam Mahajan, Jim Strait, Shekhar Mishra, Brajesh Choudhary, Baba Potukuchi

Cryostat Design



The LNGC "Tembek", one of the thirty-one 216,000 m³ LNG carriers ordered by Nakilat and delivered in 2008

IHI Membrane Technology

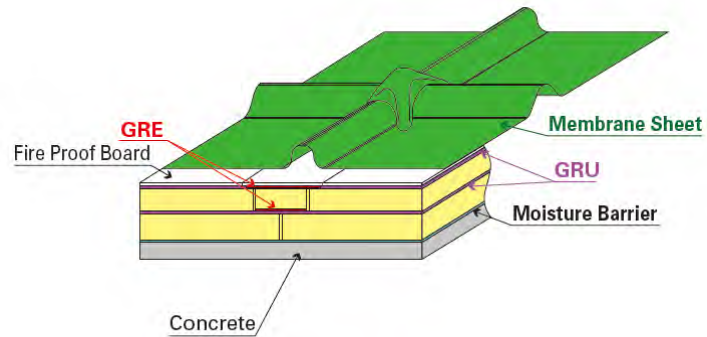

GRE: Glass Cloth Reinforced Epoxy
GRU: Glass Cloth Reinforced urethane

Vendors: Gaz Transport & Technigaz (GTT)
Ishikawajima-Harima Heavy Industries Co., Ltd. (IHI)

Nominal Panel Size
3m x 8m x 2 mm thickness

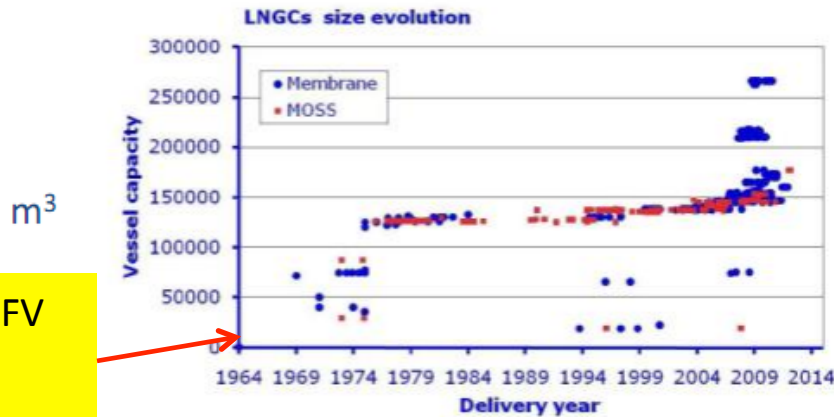

Each LBNE 5kt FV cryostat is 7,100 m³

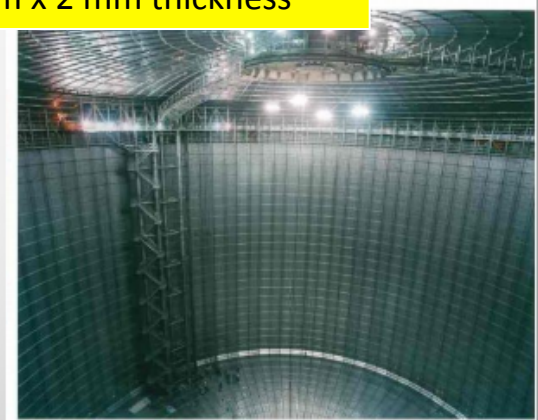

LNG Storage with Membrane from IHI

To date more than 200 vessels and 30 storage tanks are equipped with GTT licensed technology.

Membrane Cryostats

GTT Membrane Technology

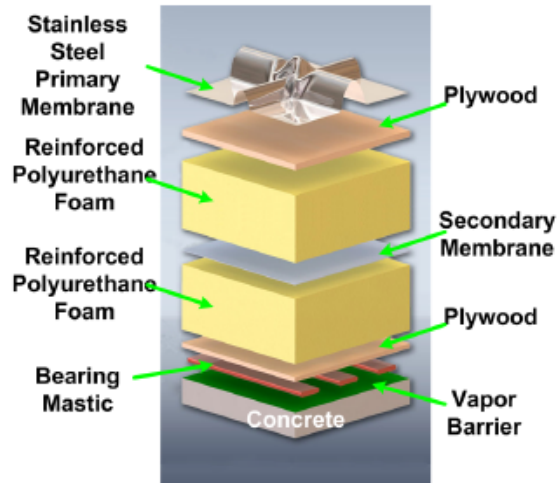

Nominal Panel Size
1m x 3m x 1.2 mm thickness

IHI Membrane Technology

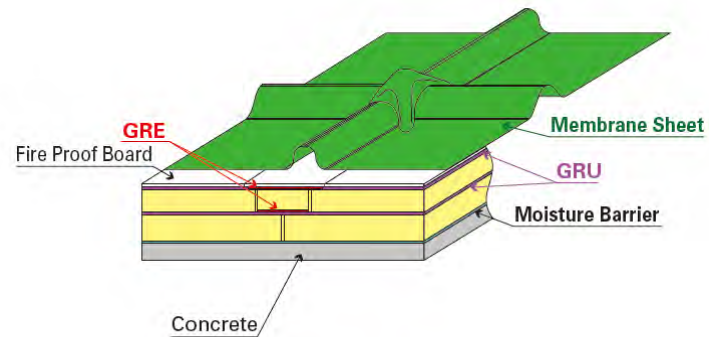

GRE: Glass Cloth Reinforced Epoxy
GRU: Glass Cloth Reinforced urethane

Nominal Panel Size
3m x 8m x 2 mm thickness

- Two 5-kton (fiducial mass) twin cryostats:
 - 18.8 kton total LAr mass
 - 13.5 kton total active mass
 - 10 kton total fiducial mass
- Estimated heat leak during steady state operations: 27.5 kW (per cryostat).
- No large vacuum hazard, no hazard from instantaneous heat leak change

Photon Detection

- The 1.4 ms drift time of the electrons is very slow.
 - The beam spill is 10 μs long – gives t_0
 - For non-beam related physics the interaction time is unknown. **Use the light to determine the event time.**
- A lot of light is produced by particles interacting in LAr
 - Both scintillation and Cherenkov radiation are generated but 5 times more scintillation light
 - 23% of the scintillation light is prompt ($\sim 6\text{ns}$)
 - 77% of the light is late ($\sim 1.6 \mu\text{sec}$).
 - Prompt yield 33,000 128nm photons per MeV for a MIP
- Detecting the light and extracting the maximum information is complicated.
 - Scattering length is $\sim 95 \text{ cm}$
 - Present coverage is 0.4%
- **Photon Detection System critical for low-energy events**

G.M. Seidel, R.E. Lanou, W. Yao,
Rayleigh scattering in rare-gas
liquids, NIM A489 (2002) 189.

Current Reference Design

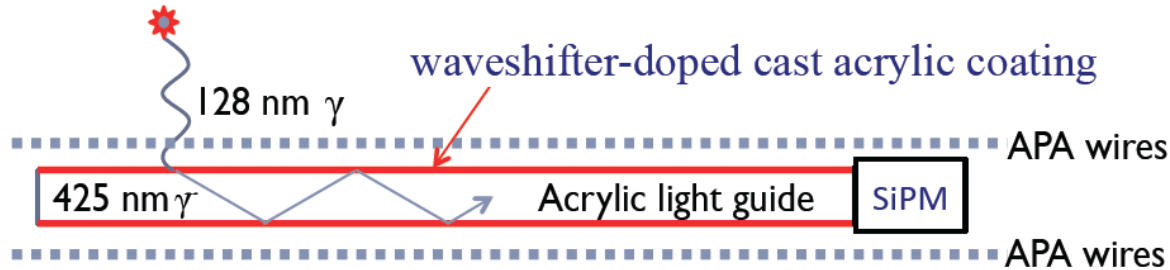

MIT inspired design

Bis-MSB coated cast acrylic
25 mm x 6 mm x 2.25 m bars
4 bars per paddle
SiPM readout

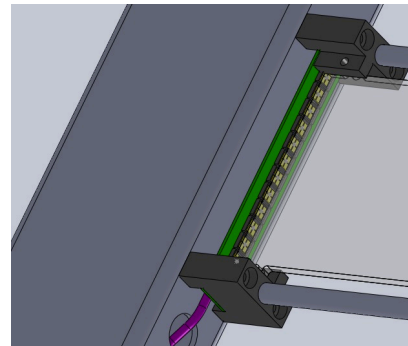
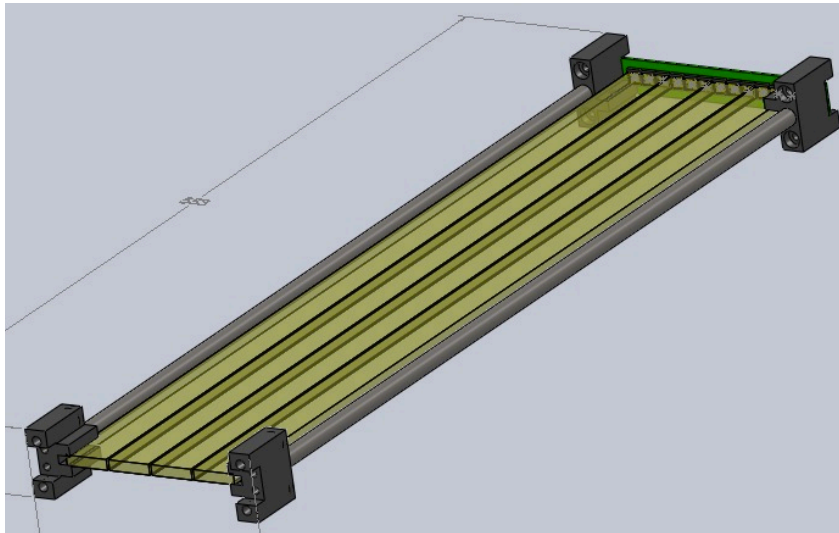

SensL MicroFB-60035-SMT
readout at LN2 temp

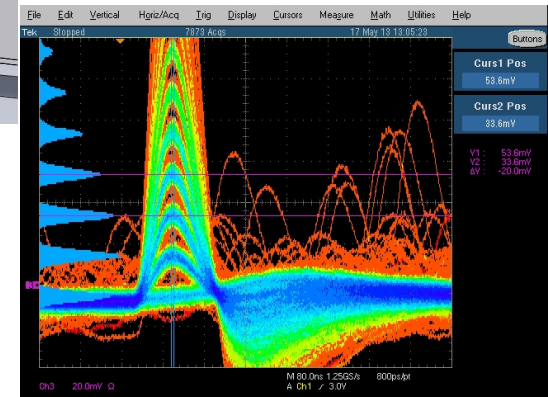

Assemblies tested in Fall

Outline

- Develop large area paddles with WLS doped in the bulk.
 - Only WLS near the surface interacts with 128 nm light
- Use bulk doped square fibers with small SiPM readout on each fiber.

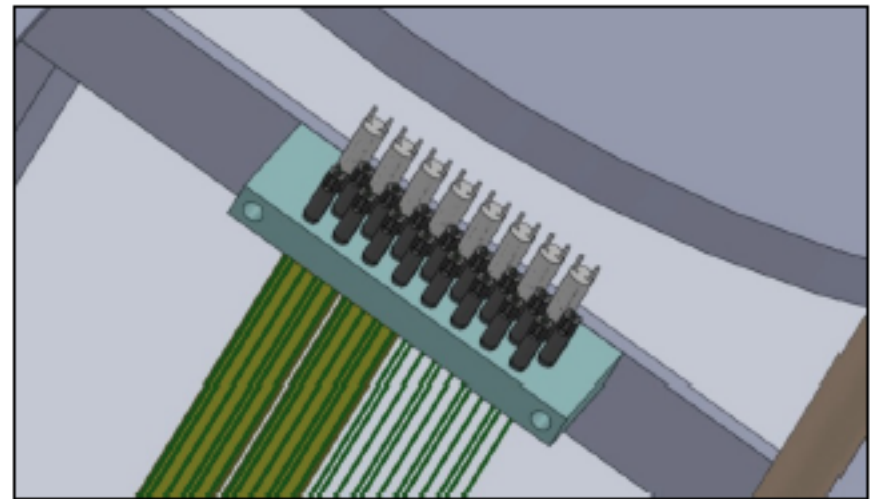
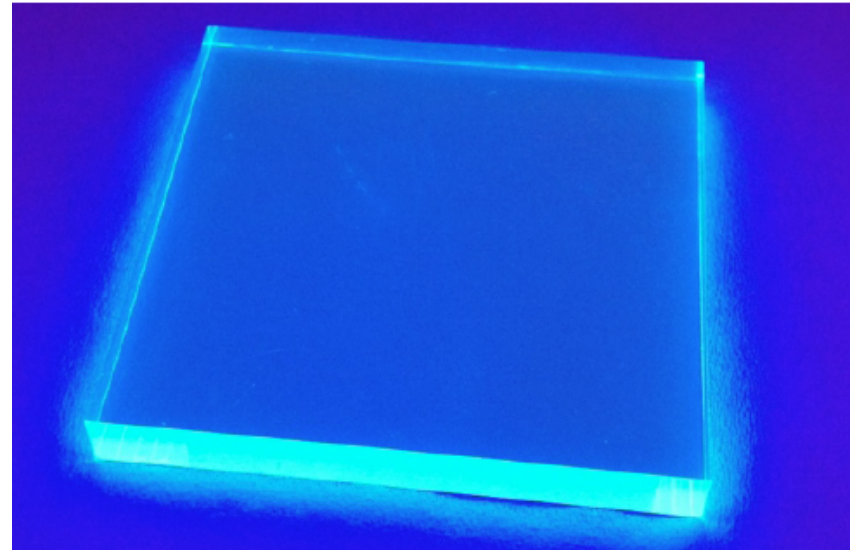

Anode Plane Assembly Close-up View

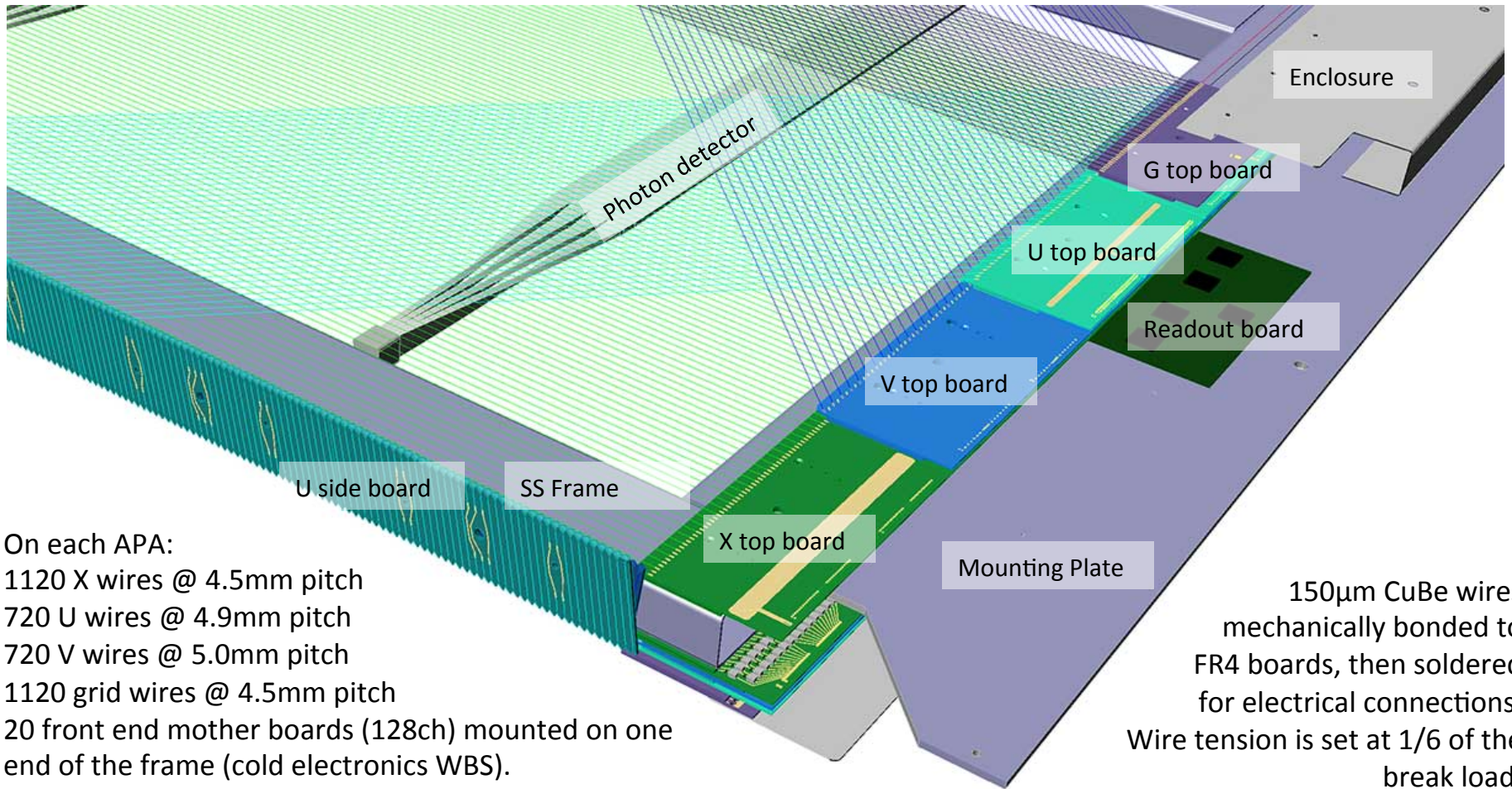

On each APA:
1120 X wires @ 4.5mm pitch
720 U wires @ 4.9mm pitch
720 V wires @ 5.0mm pitch
1120 grid wires @ 4.5mm pitch
20 front end mother boards (128ch) mounted on one end of the frame (cold electronics WBS).
10 photon detectors installed inside the APA frame (photon detectors WBS)

150 μ m CuBe wires mechanically bonded to FR4 boards, then soldered for electrical connections. Wire tension is set at 1/6 of the break load.
Dead space is 15mm along vertical APA joints and 27mm between horizontal joints.

35 t Prototype Cryostat and TPC

IHI construction

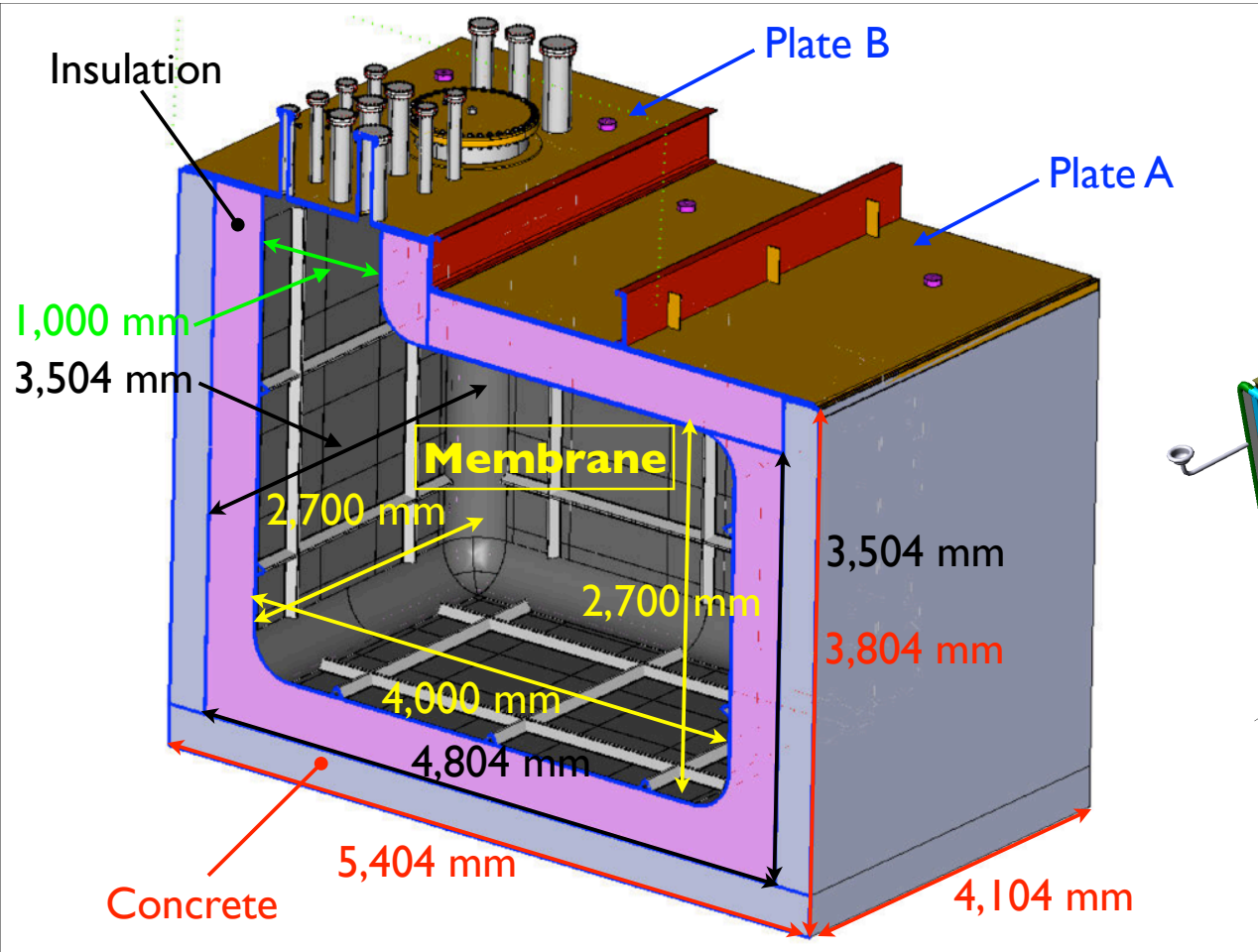

TPC

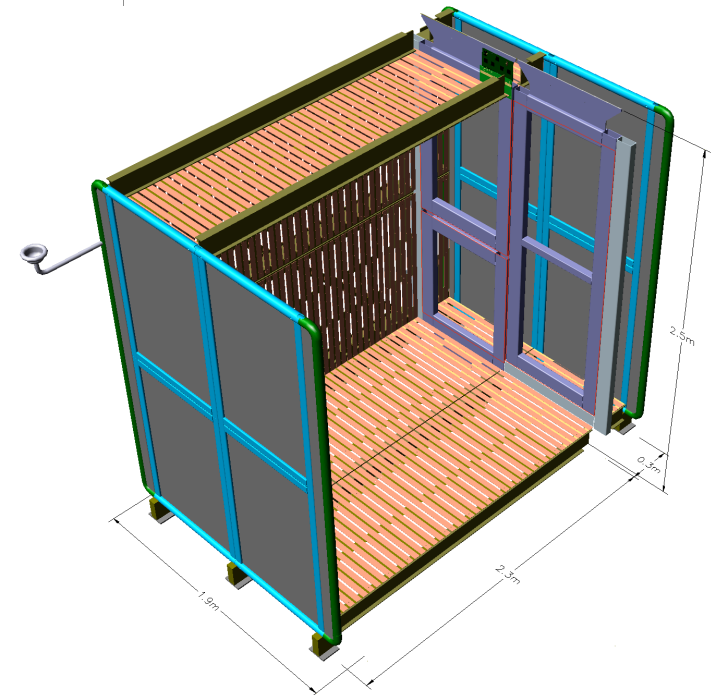

- Test the cryostat this fall and install a TPC next year

Prototype Construction

3 D Model of IHI Tank

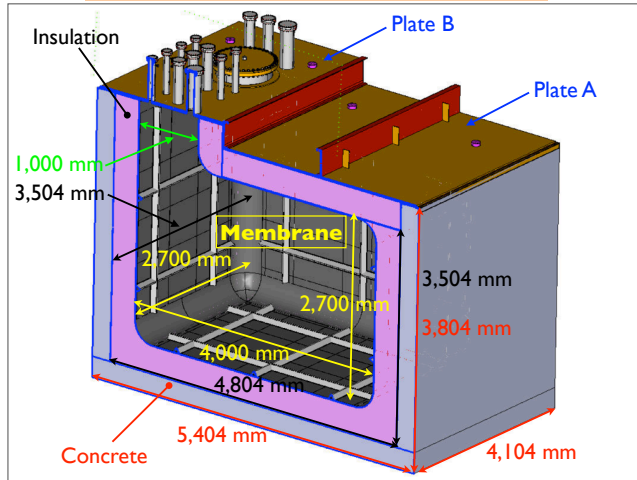

Concrete Structure @ PC4

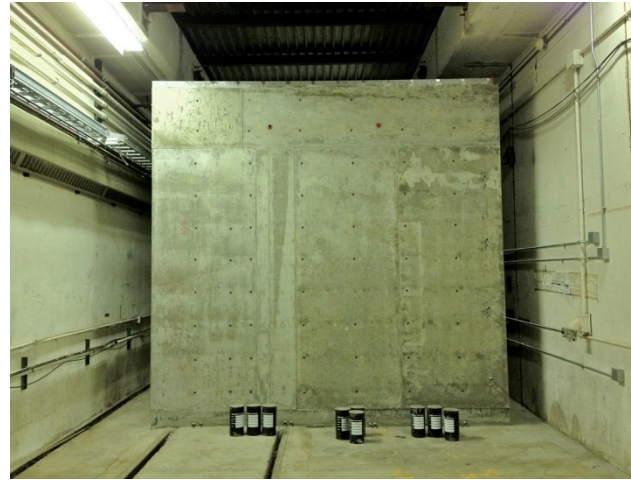

Carbon Steel Vapor Barrier

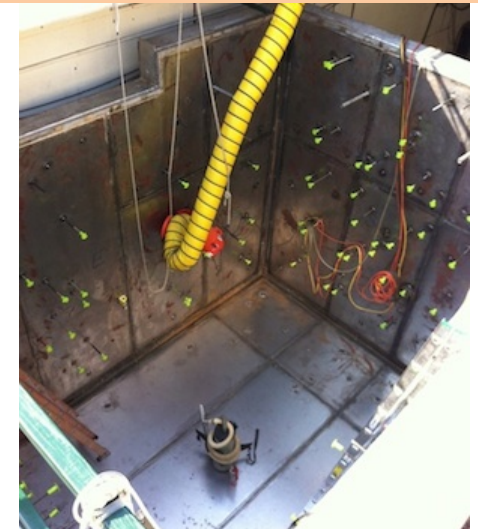

Two layers of foam (0.4 m)



Top View of Two Layers Foam



SS membrane Insert Begins