

# ORC process for reducing power consumption at the energy recovering electron cooler system for FAIR

Kurt Aulenbacher, Helmholtz-Institut Mainz (HIM)  
24. October 2013

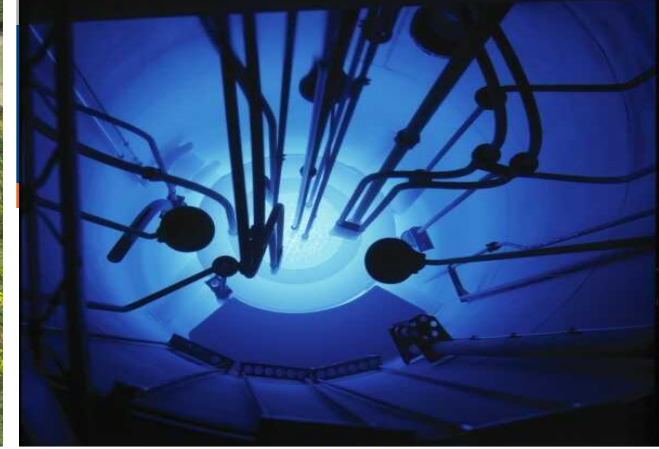
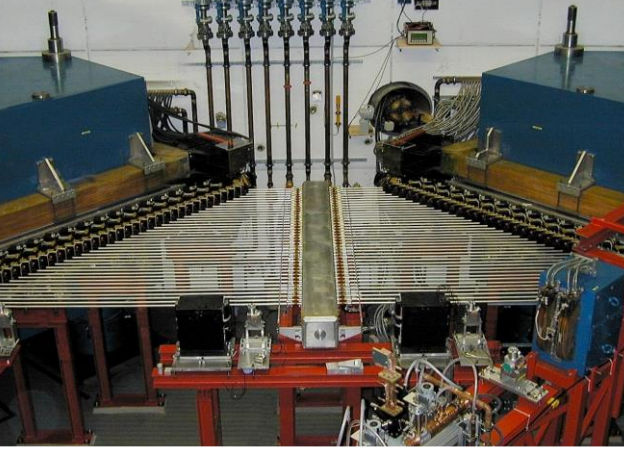

- HIM is a joint venture between GSI & University of Mainz
- HIM-section: Accelerators & Integrated Detectors (ACID)
- One project: FAIR/HESR related research (electron cooler) (HESR consortium - leading institute: Forschungszentrum Jülich)

Kurt Aulenbacher, Helmholtz-Institut Mainz (HIM) 24. October 2013

# Outline

- 1. Energy recovering accelerators**
- 2. Example: Electron coolers**
- 3. ORC as a (potential) solution for a special problem in electron cooling**

## Basic types of particle accelerators

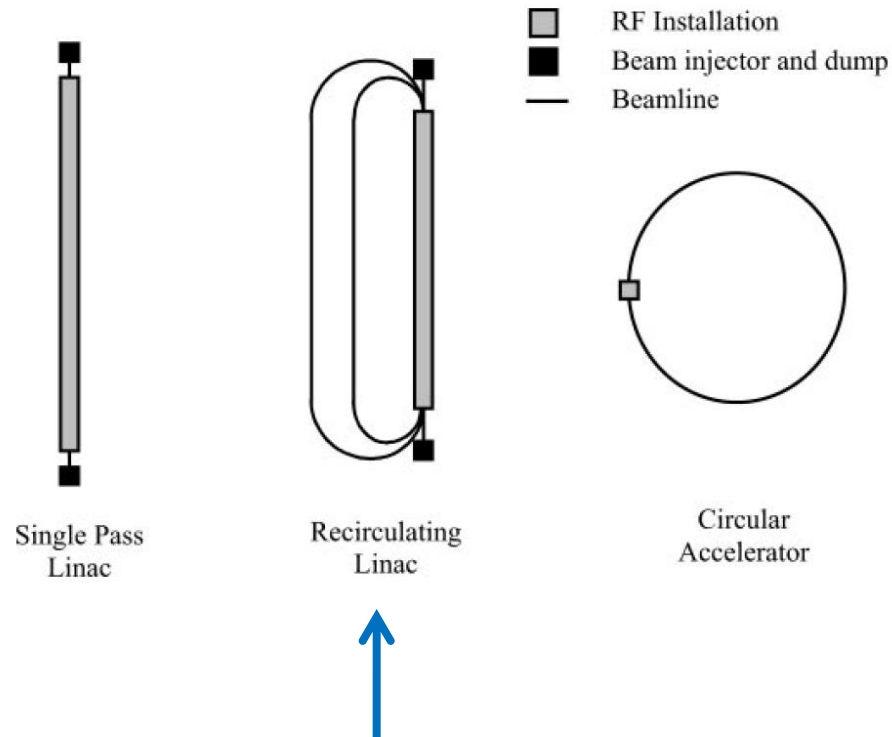

Recirculating Linacs:

~1980's: used for **cost/power** reduction  
in c.w. –machines (Mainz, JLAB)

>2000: New Principle: **Energy recovery Linac:**

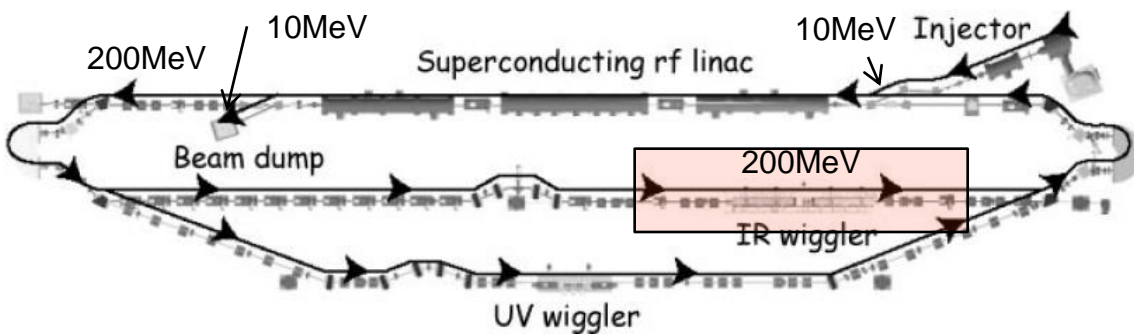
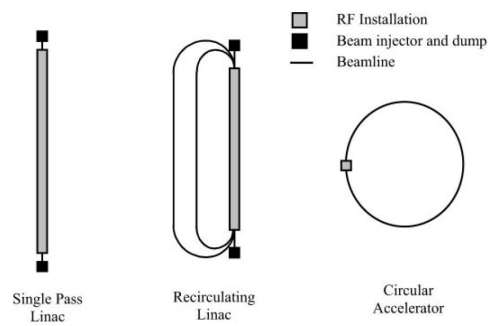

Figure 6 Schematic of JLab 10-kW IR/1-kW UV FEL upgrade configuration

TABLE 3 System parameters of the JLab IR and UV FEL upgrade

Parameter	IR FEL Upgrade	UV FEL
Beam energy at wiggler	80–210 MeV	200 MeV
Average beam current	10 mA	5 mA
Bunch charge	135 pC	135 pC
Bunch repetition rate	74.85 MHz	74.85 MHz
Normalized emittance (rms)	13 mm-mrad	5–10 mm-mrad
Bunch length at wiggler (rms)	200 fs	200 fs
Peak current	270 A	270 A
FEL extraction efficiency	1%	0.25%
$\delta p/p$ before wiggler (rms)	0.5%	0.125%
$\delta p/p$ after wiggler (full)	10%	5%
CW FEL power	>10 kW	>1 kW

L. Merminga et al.  
Annu Rev. Part. Sci. 53:387-429 (2003)



Note: beam power in Interaction region is 2MW  
But RF-power needed is only 100kW

Comparing Ring and ERL:

- The ring recirculates particles, the ERL recirculates also the energy
- In ERL, each particle passes the interaction region **only once**
- Much stronger interaction possible in ERL-mode!
- ERL emittance in stationary equilibrium much better

Potentail large scale Application:

eN-Colliders or advanced light sources with GW-beam powers

# MAMI & MESA at IKP-Mainz

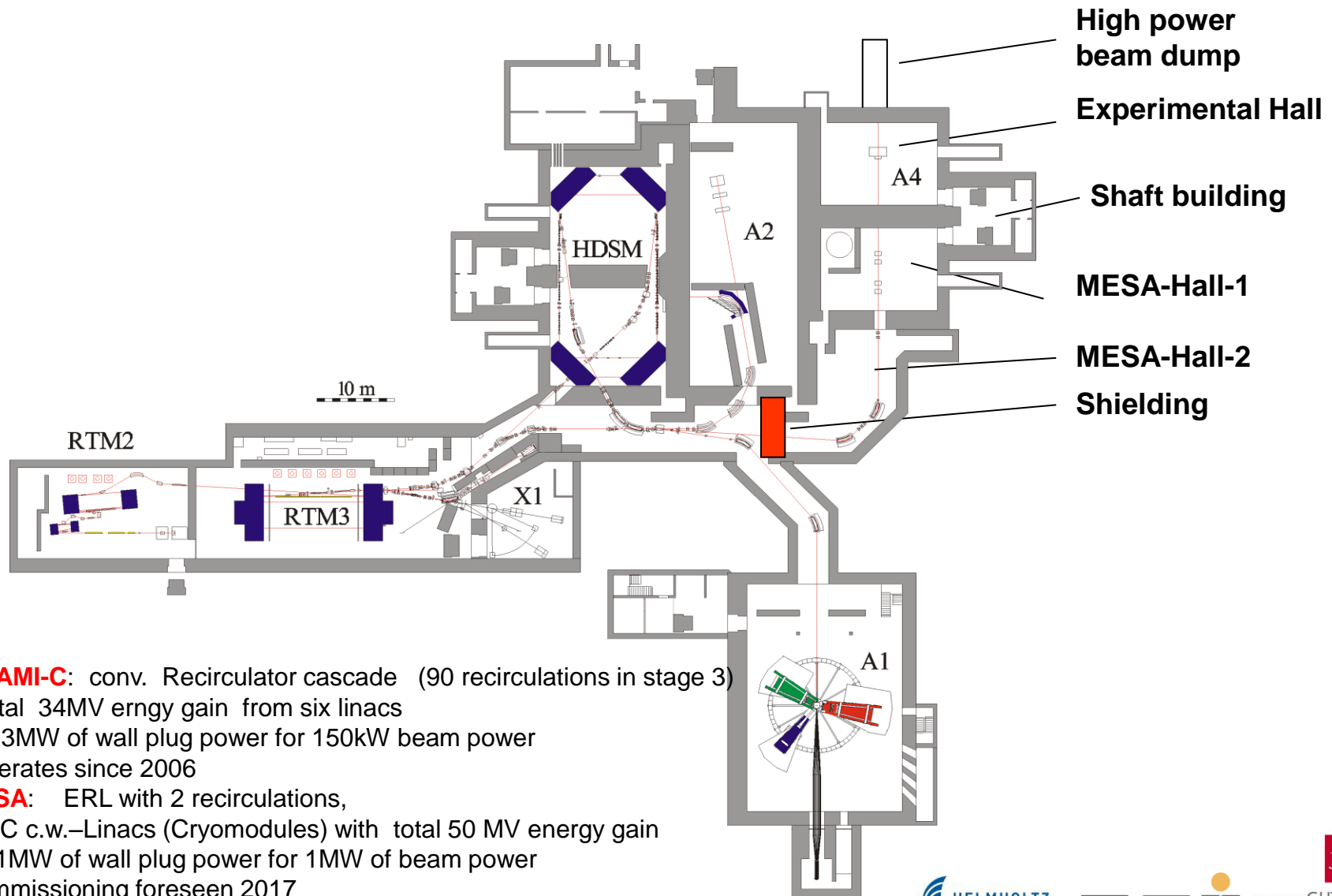

- **MAMI-C:** conv. Recirculator cascade (90 recirculations in stage 3)  
total 34MV energy gain from six linacs  
→ 3MW of wall plug power for 150kW beam power  
operates since 2006
- **MESA:** ERL with 2 recirculations,  
2 SC c.w.-Linacs (Cryomodules) with total 50 MV energy gain  
→ 1MW of wall plug power for 1MW of beam power  
commissioning foreseen 2017

# MESA-Layout

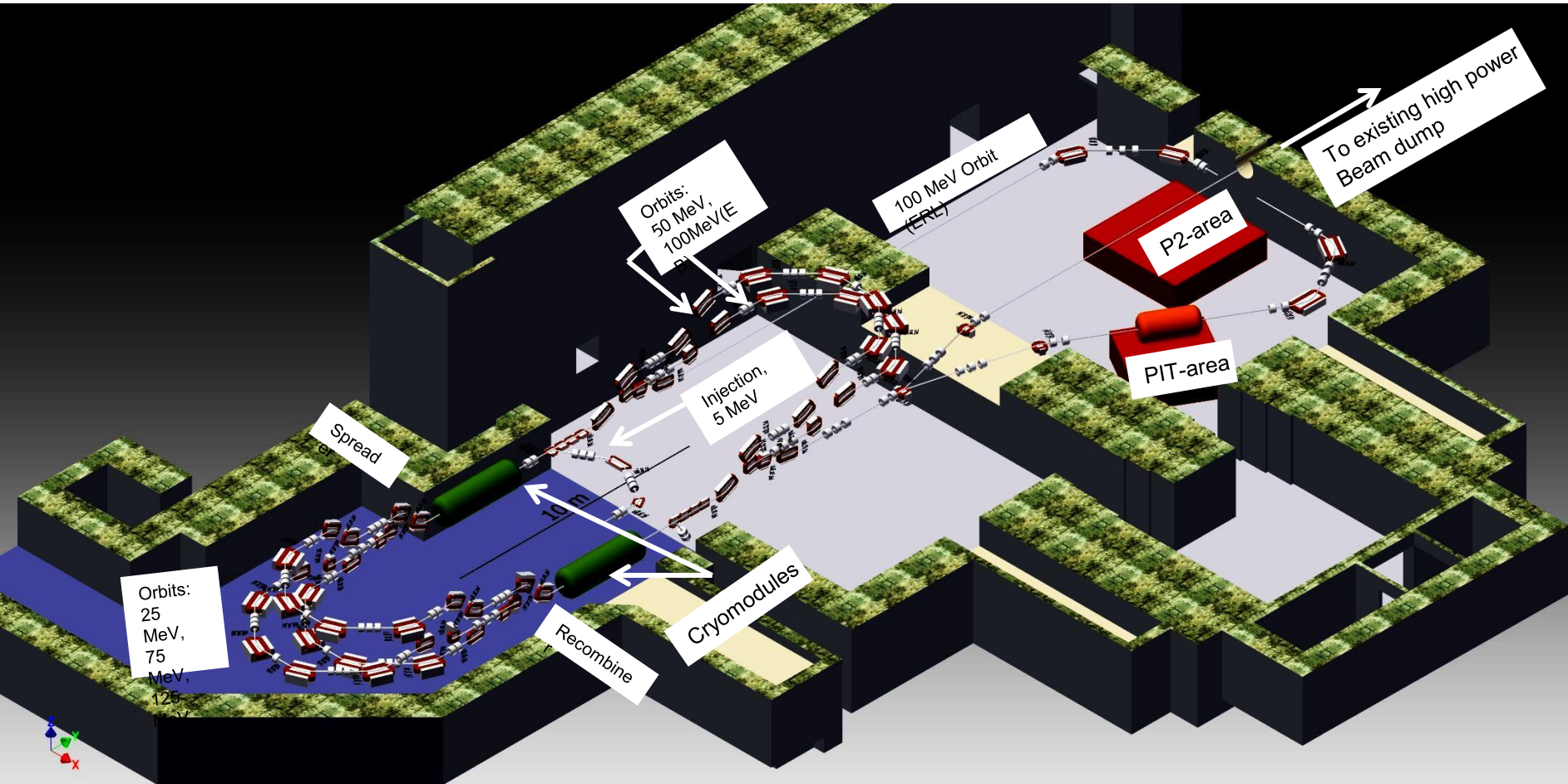

Lattice inspired by CERN-LHeC test facility approach

# Similar - but also different: Electron coolers

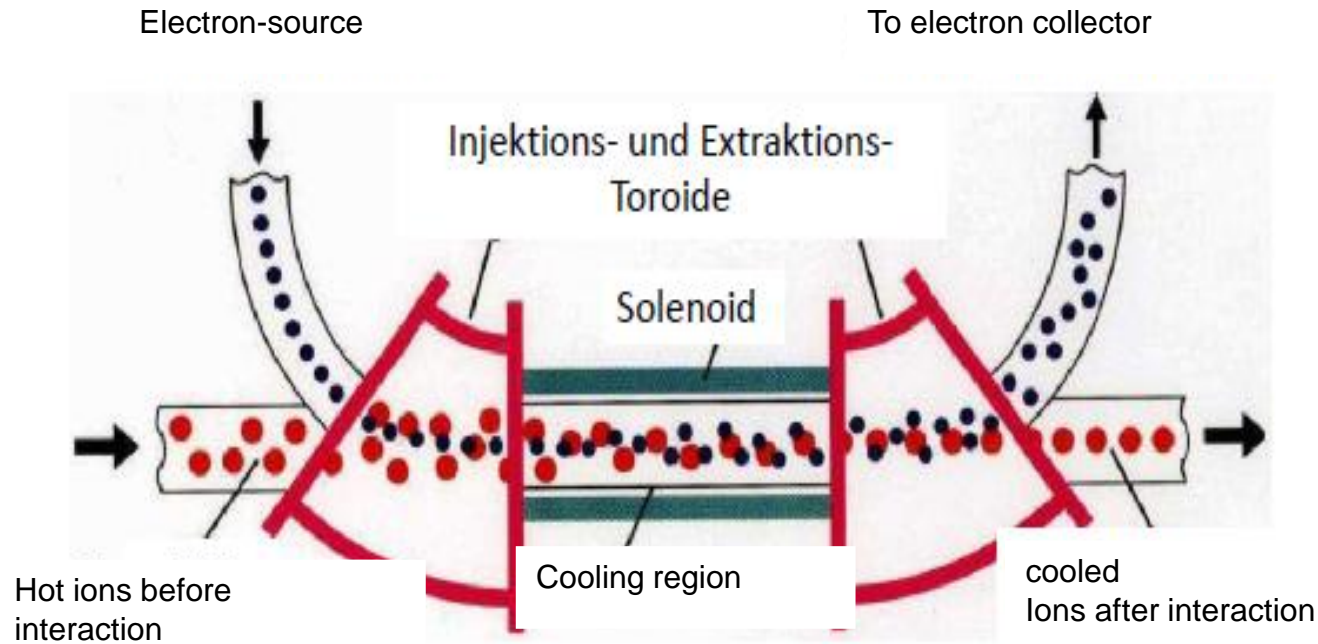

Condition:  $v_{\text{ion}} = v_{\text{elec}} \rightarrow$  relativistic-limit:  $E_{\text{ion}} = (m_{\text{ion}}/m_{\text{el}}) * E_{\text{el}}$



# 50Tm HESR-ring at FAIR



Full antiproton energy of HESR ~14GeV  
 → Electron beam energy max. 8MeV  
 Beam power for efficient cooling 4-24 MW

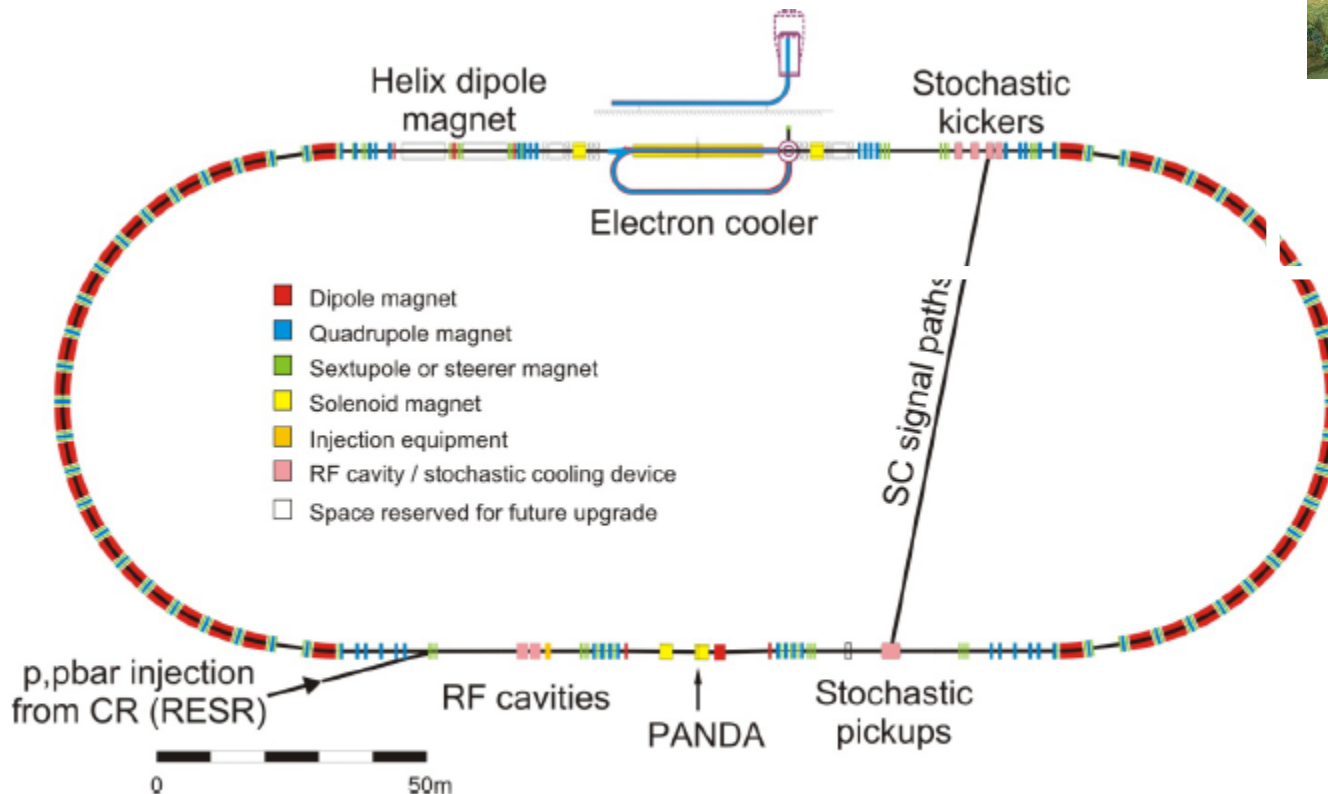
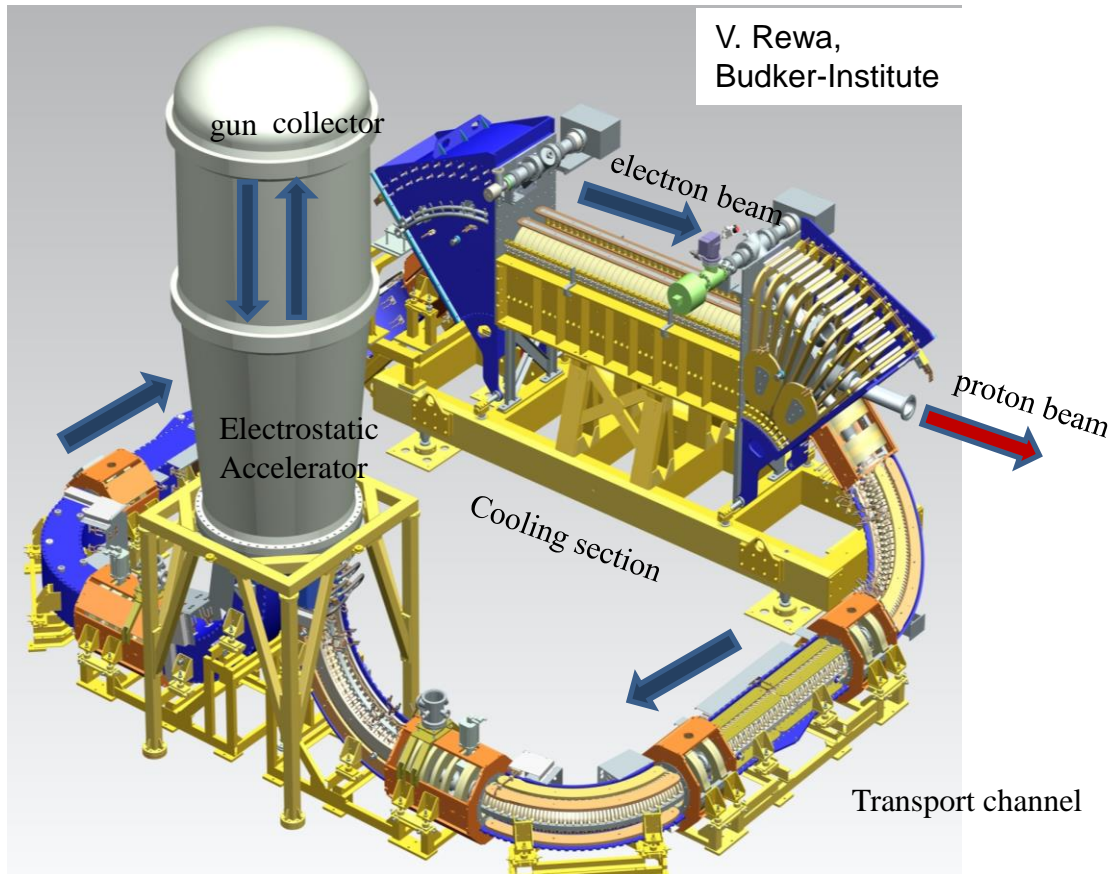

Figure 1: Schematic view of the HESR. Positions for injection, cooling devices and experimental installations are indicated. The upper straight is housing electron cooler, stochastic kickers, and space for a future upgrade. The lower arc section contains RF cavities, stochastic pickups, and the PANDA experimental installation.

# 3D design of COSY Cooler



## New cooler at COSY/Jülich

Designed by Budker  
Institut Novosibirsk  
for FZ Jülich.  
(in commissioning, first  
Cooling of 200MeV  
protons Sunday, 20.10.  
2013

-“magnetized beam“

-2MW of beam power

V. Rewa,  
Budker-Institute

## 2MV cascade transformer

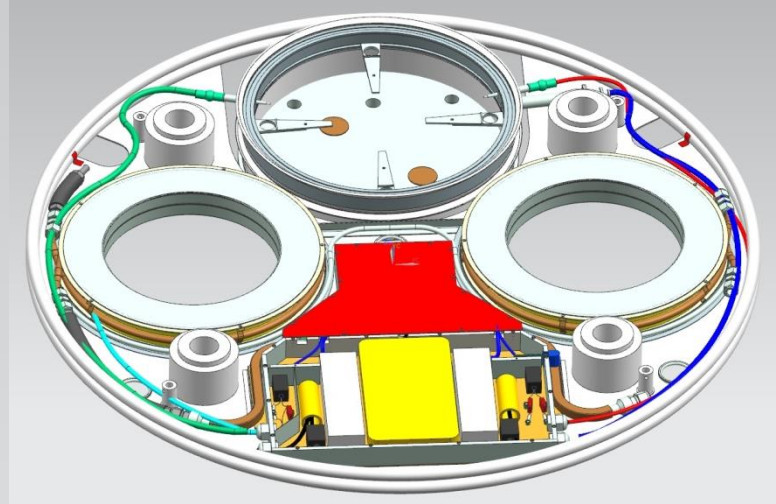
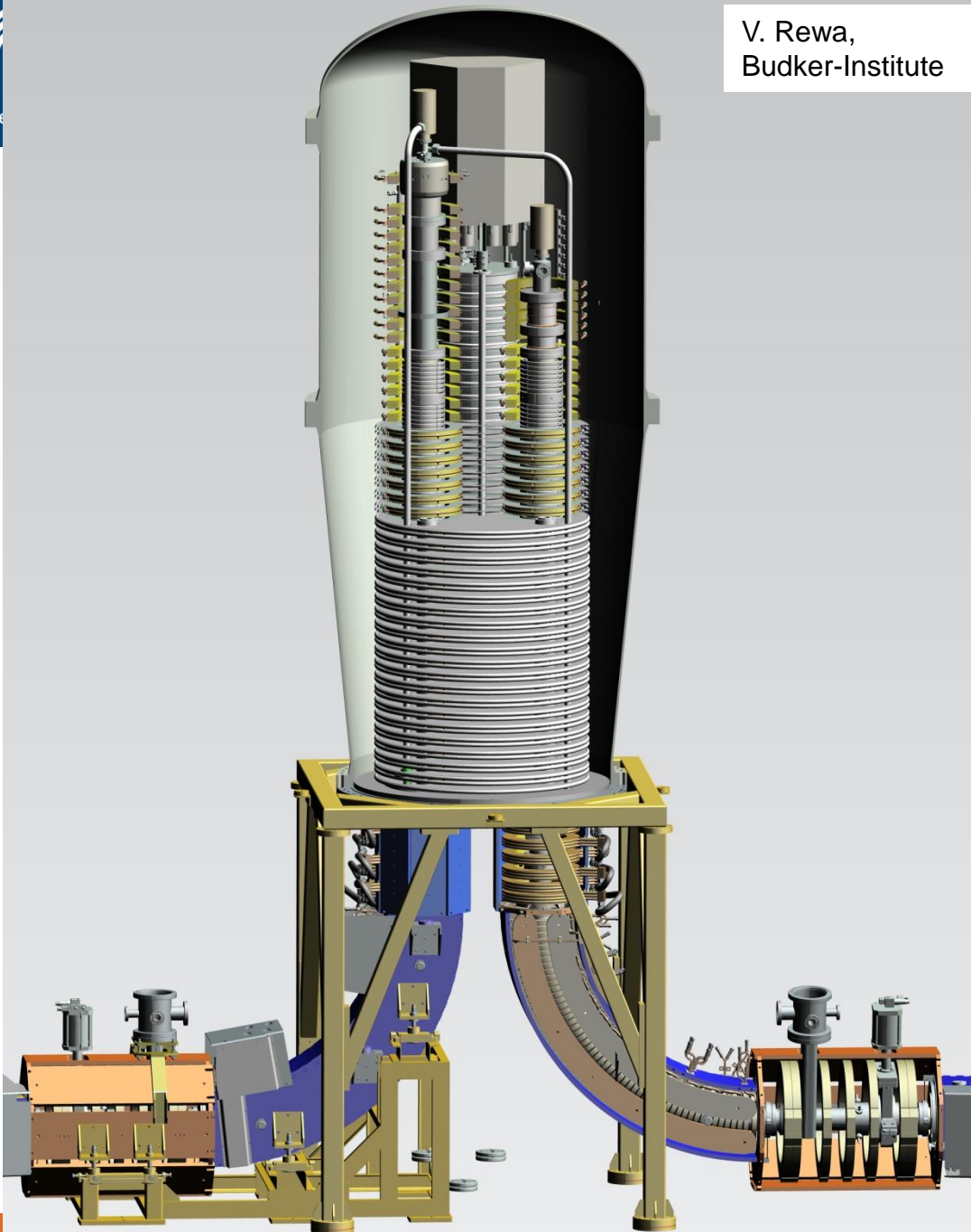

*Each section contains;*

- high-voltage power supply +/- 30 kV;*
- power supply of the coils of the magnetic field (2.5 A, 500 G);*
- section of the cascade transformer for powering of all electronic components;*

*33 high-voltage section*

## 8MV HESR cooler

### HESR cooler: solenoid channel problem & turbine concept

- Solenoids must be powered by floating power supply.
- Turbines for  $U > 2\text{MV}$  → Suggestion of BINP-Novosibirsk: 60kV/Turbogen (400Watt)
- **Not realized** for Jülich 2MV-cooler due to **unreliability** of Turbogen (status 2009)
- 2012: ACID contacts German company DEPRAG: Offer for 5kW Turbogens, high reliability  
(V. Parkomchuk: Each 5kW Turbogen may excite 500kV Cascade transformer)

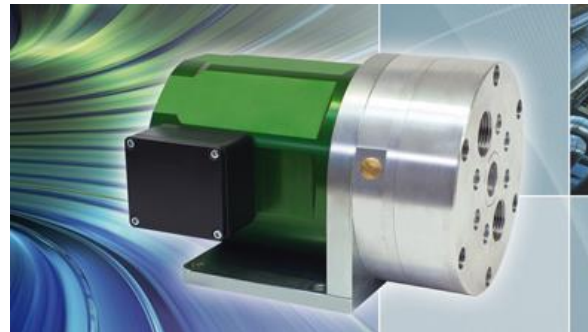

~40cm

Two 5kW Turbogenerators have been ordered, delivery 11/2013  
(Design differs from catalogue illustration , 8000 hour operation specified)

# Turbine powered floating power generator prototype

500kV cascade transformer

10\*50kV d.c-supplies

Converter

Turbine

SF6-pressurized vessel

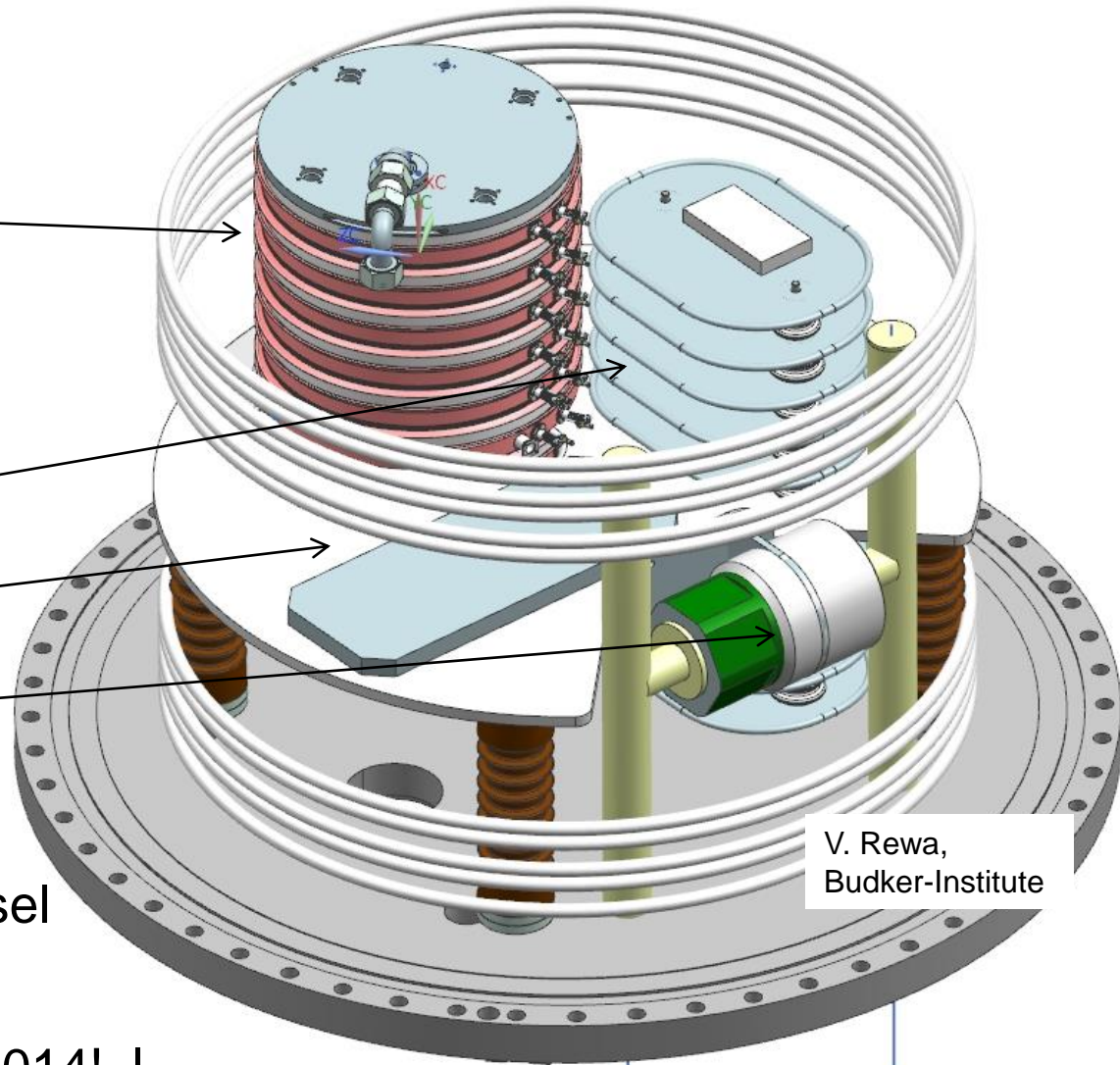

V. Rewa,  
Budker-Institute

Prototype testing at BINP in 2014! |

# Goal: Multi-MV stack

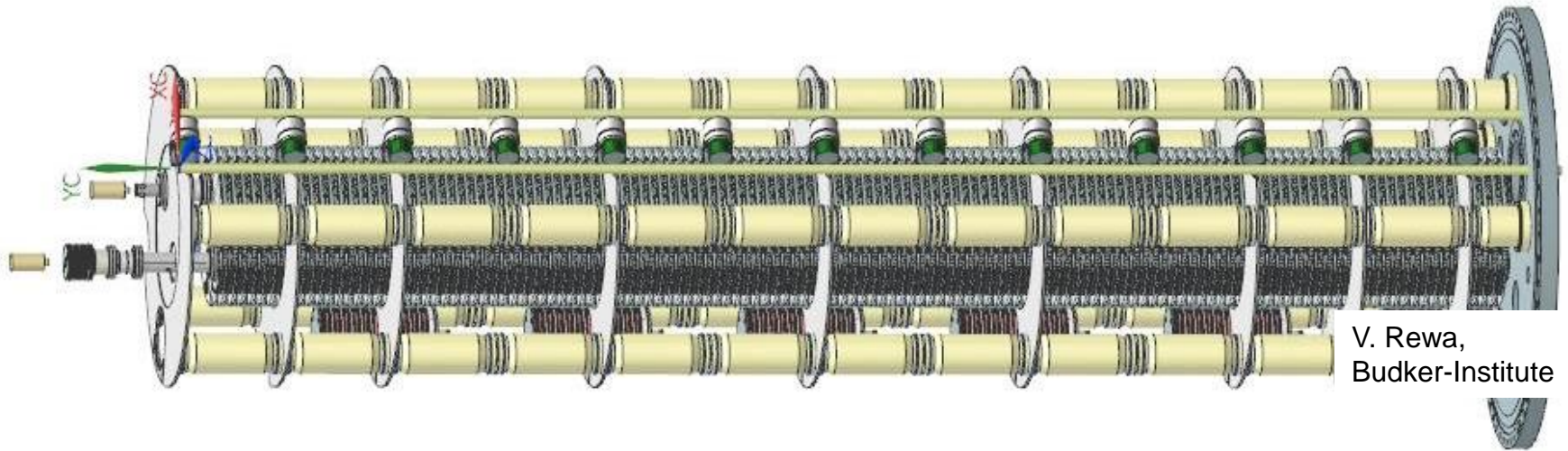

V. Rewa,  
Budker-Institute

## Technical challenges:

- Using SF6 as fluid is desirable (Turbines not optimized)
- Kompressor for expansion turbines is not energy efficient

**New idea: SF6 is gas with capabilities as ORC medium**

# Goal: Multi-MV stack

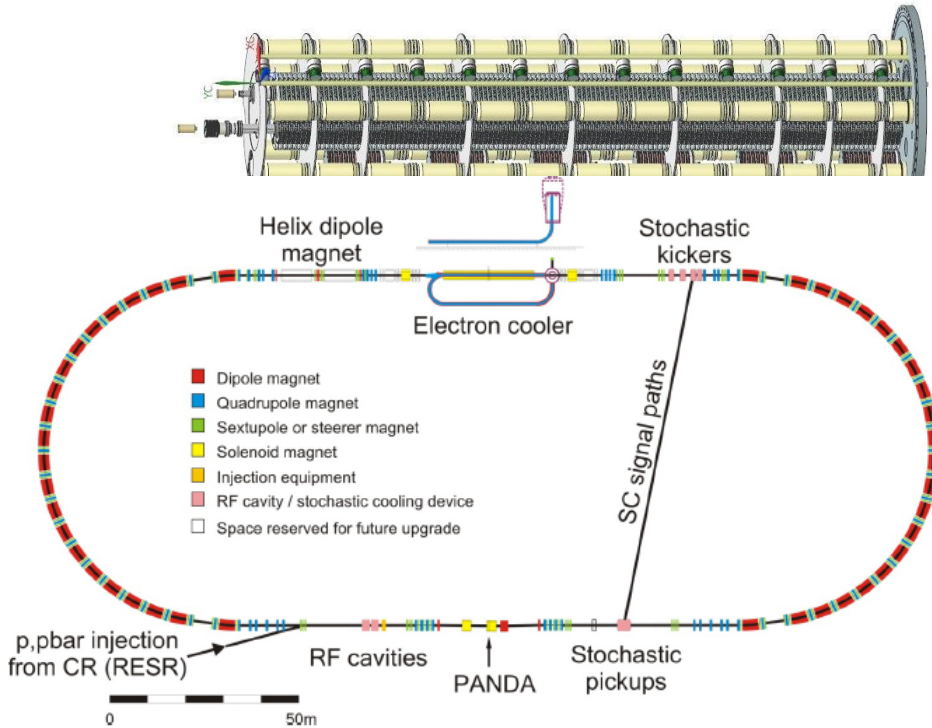
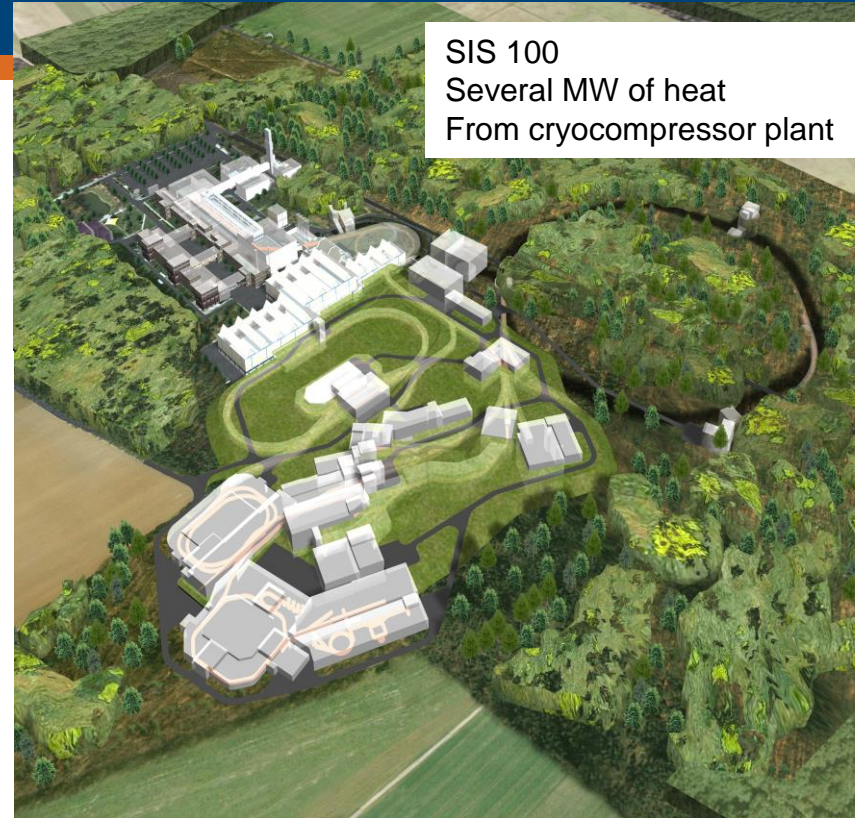

Figure 1: Schematic view of the HESR. Positions for injection, cooling devices and experimental installations are indicated. The upper straight is housing electron cooler, stochastic kickers, and space for a future upgrade. The lower

**New idea: SF6 is gas with capabilities as ORC medium:  
Research study for layout of plant in the near future!**

# HESR cooler: timeline 2013-18

- 2 Turbogenerators ordered, delivery to BINP end of 2013
- Challenge: Convert Turbogen to SF6 medium/energy efficiency: full scale device requires ~1.5MW of electrical power for compressor.
- Negotiations with Universities on facing these challenges



~40cm

## Main Projects/Milestones for the mid term future together with partners/collaborators:

- |  |             |
|--|-------------|
| 2014- Operation/Optimization of Turbogenerators using SF6  | (TU-collab) |
| 2016 explore using Organic Rankine Cycle (ORC) instead compressor<br>→ reduce el. energy consumption by order of magnitude | (TU-collab) |
| 2014: Demonstration of Turbo powered HV generator  | (BINP, FZJ) |
| 2016: Study/design of full scale SF6 gas handling system   | (Industry)  |
| 2016: Decision on feasibility of concept   | (BINP, FZJ) |
| 2017: Technical design report for full scale cooler  | (BINP, FZJ) |

Alternatives  
are being  
studied in  
paralle!





Thank you for your attention