



# LHCb latest results, an overview

Cristina Lazzeroni (Birmingham)  
on behalf of the LHCb collaboration



Triggering Discoveries in High Energy Physics  
University of Jammu, India - 9-14 September 2013

# Two ways to New Physics

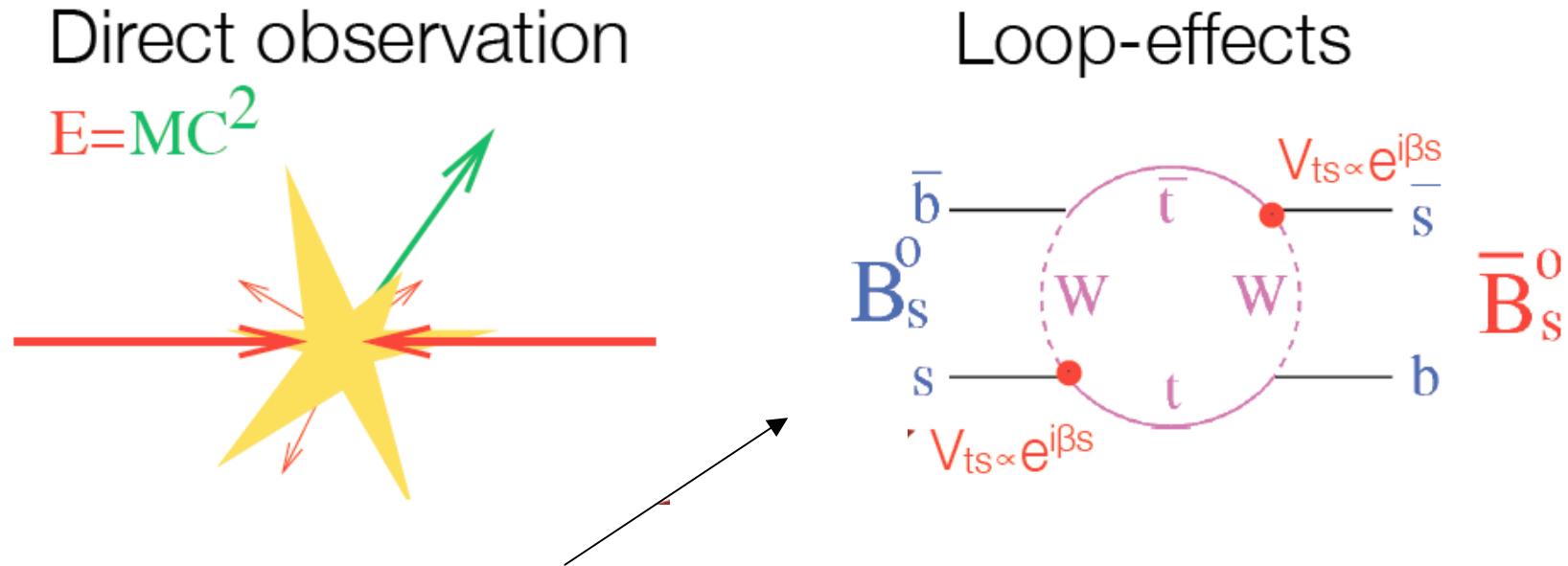

This approach is sensitive to particles far heavier than those produced directly at colliders.

This is what Flavour Physics is about: it lets us see beyond the Energy Frontier.

The key: precision

# Search for New Physics in Flavour Sector

Look for new physics in quantum loops as corrections to Standard Model processes:

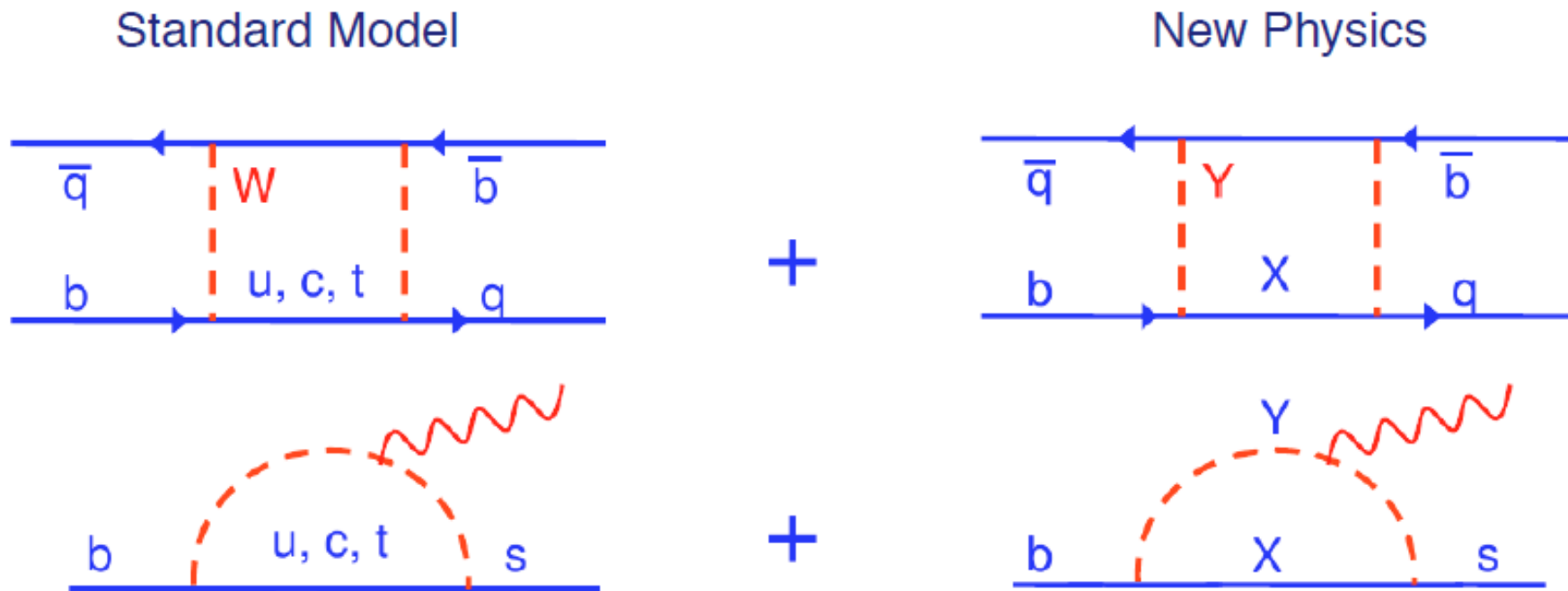

$$\mathcal{A}_{BSM} = \mathcal{A}_0 \left( \frac{C_{SM}}{m_W^2} + \frac{C_{NP}}{\lambda_{NP}^2} \right)$$

# Quark Flavour Physics: CP violation, rare processes

Quark Flavour Physics: precision study of quark transitions - the only known source of CP violation

- Test CKM mechanism and SM to ultimate precision
- Tool for searching for new physics in quantum processes

Beauty and Charm systems are excellent laboratories

A few prominent examples:

**CKM mechanism:** CP violation angle  $\gamma$  (with  $B \rightarrow Dh$ ),

CPV in  $B^0_s$  (with  $B^0 \rightarrow K^+ \pi^-$ ,  $B^0_s \rightarrow \pi^+ K^-$ )

**Processes very sensitive to quantum loops:**

Mixing frequency and phase of  $B^0_s$  oscillations

( $B^0_s \rightarrow D^-_s \pi^+$ ,  $B^0_s \rightarrow J/\psi K^+ K^-$ ,  $J/\psi \pi^+ \pi^-$ )

Flavour Changing Neutral Current processes

( $B^0_{(s)} \rightarrow \mu^+ \mu^-$ , Angular observables in  $B^0 \rightarrow K^{*0} \mu^+ \mu^-$ )

# The LHCb Detector

Forward detector ( $2 < \eta < 5$ ), b hadrons produced at low angle  
 Large bb cross section ( $\sim 250 \mu\text{b} - 500 \mu\text{b}$  @  $\sqrt{s} = 7 - 14 \text{ TeV}$ )  
 $> 70\%$   $K_s$  decay after the Vertex Locator (VELO)  
 Harsh hadronic environment :  
 (1/200 event contains a b quark, typical interesting BR  $< 10^{-3}$ )

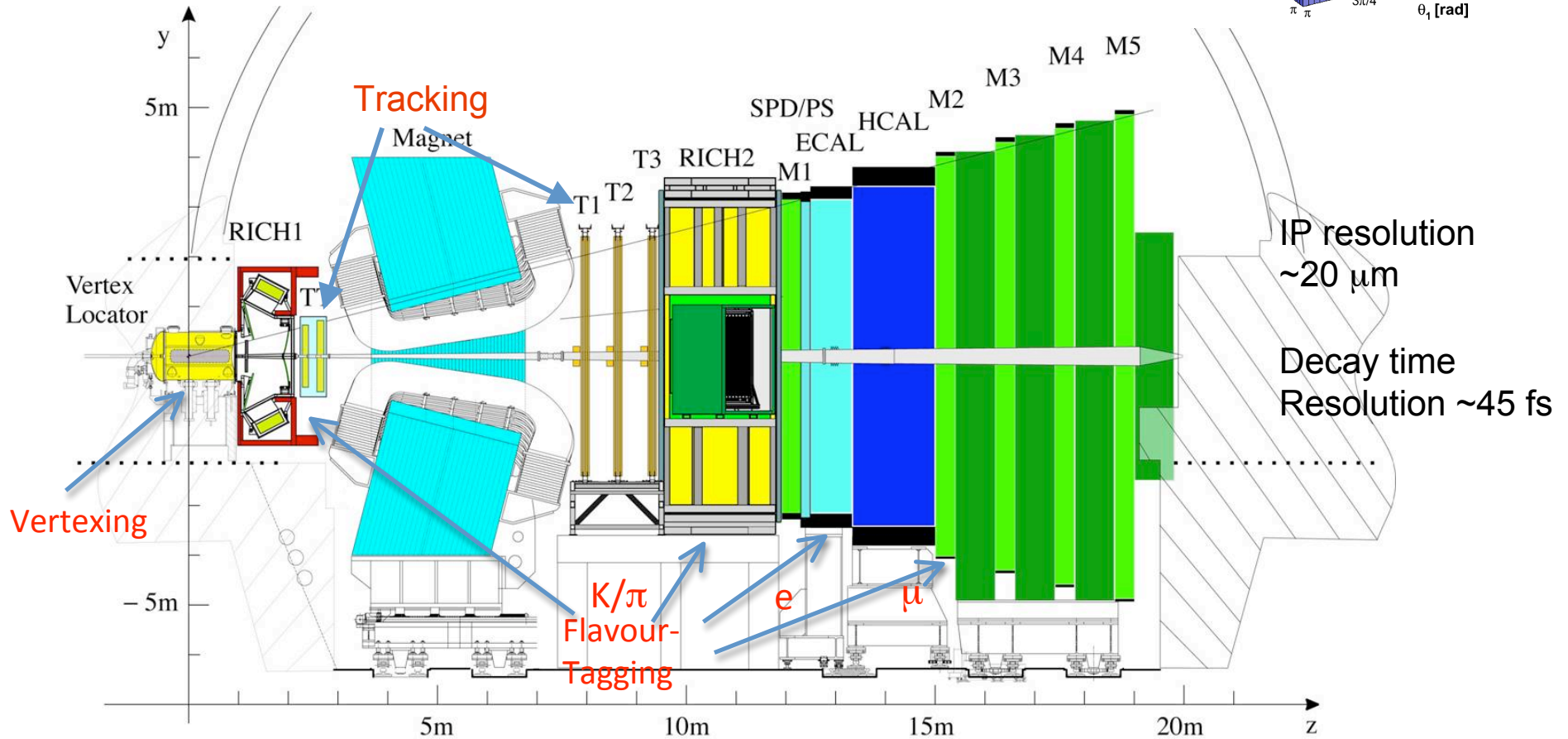
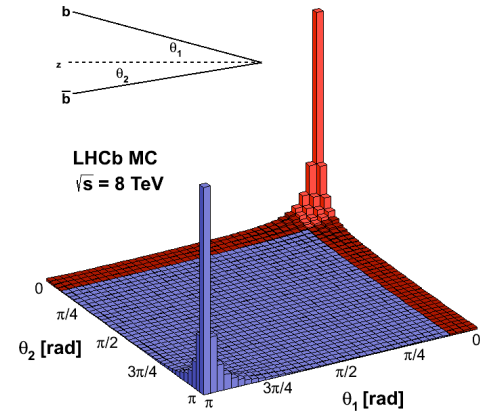

# B events at LHCb

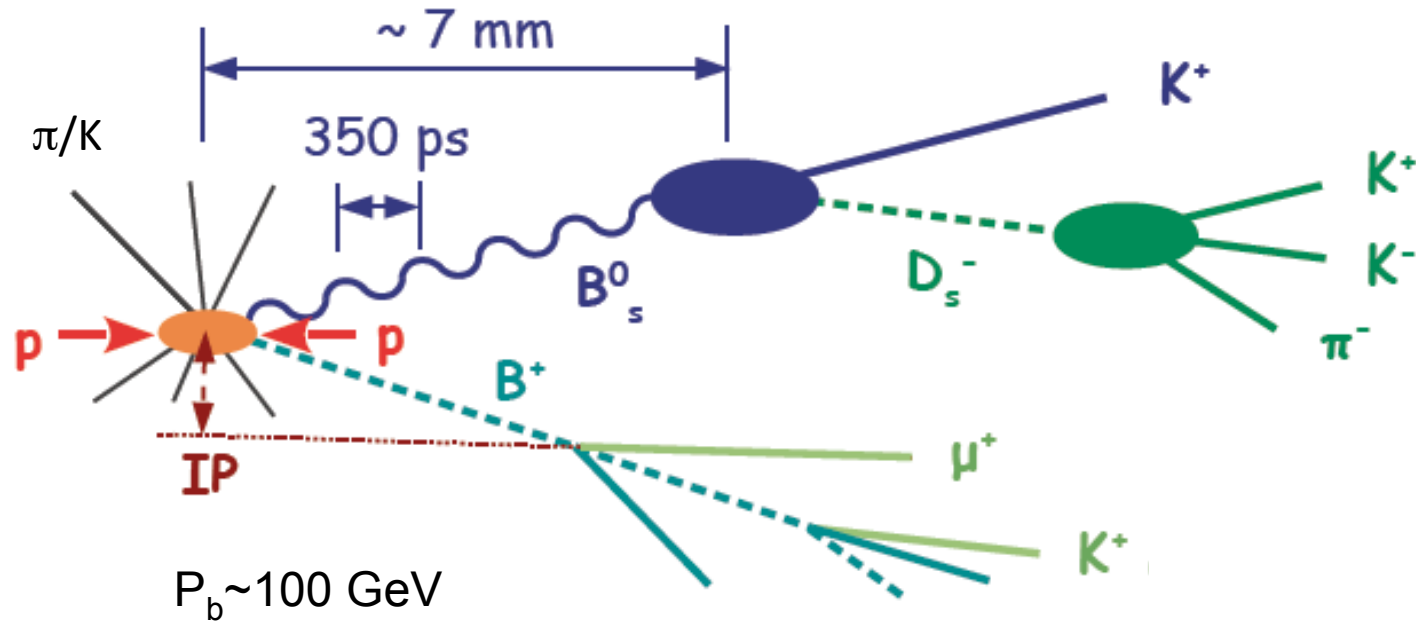

$K, \pi, \mu$  final states

# CP Violation

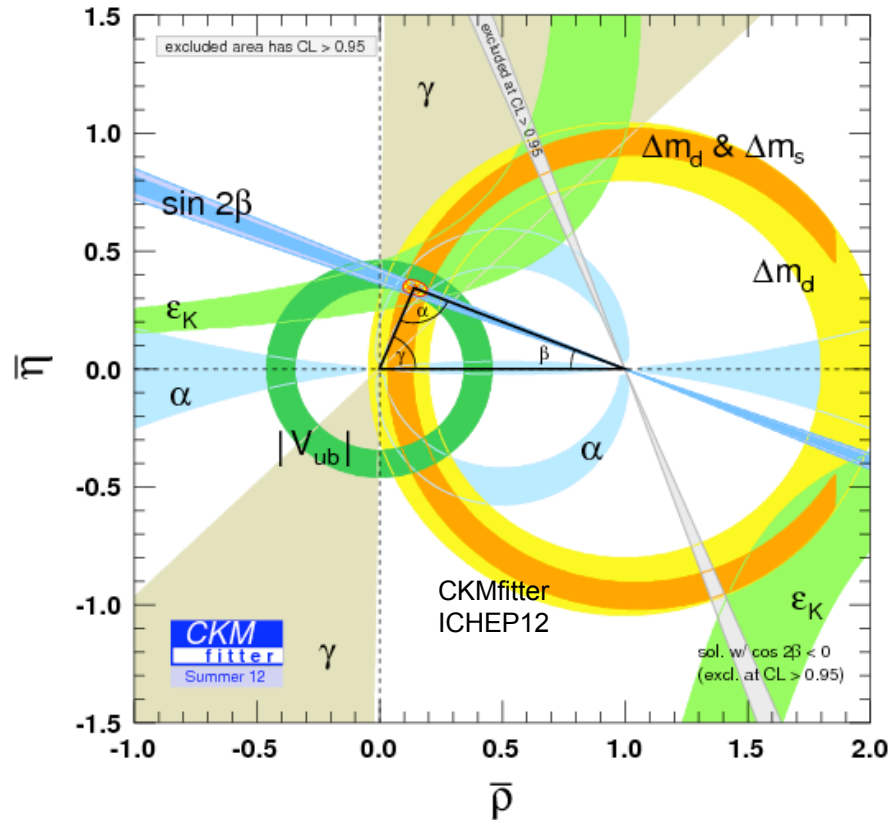

Current average  
from direct measurements:

$$\gamma = (69^{+17}_{-16})^\circ \text{ (Babar)}$$

[arXiv:1301.3283v1]

$$\gamma = (68^{+15}_{-14})^\circ \text{ (Belle)}$$

[CKM2012]

Triangle shown is b-d;  
LHCb is sensitive also  
to b-s triangle:

**Shown today  $\gamma$  (b-d triangle)  
and first observation  $> 5\sigma$  of  
CPV in  $B_s$  (b-s triangle)**

$\gamma$  is the only angle that can be measured entirely with tree decays.  
Tighter experimental constraints on  $\gamma$  come from loops, which  
are sensitive to new physics.

**$\gamma$  : test CKM to ultimate precision, and compare tree and loop  
processes**

# $\gamma$ Measurement with tree decays: $B \rightarrow Dh$

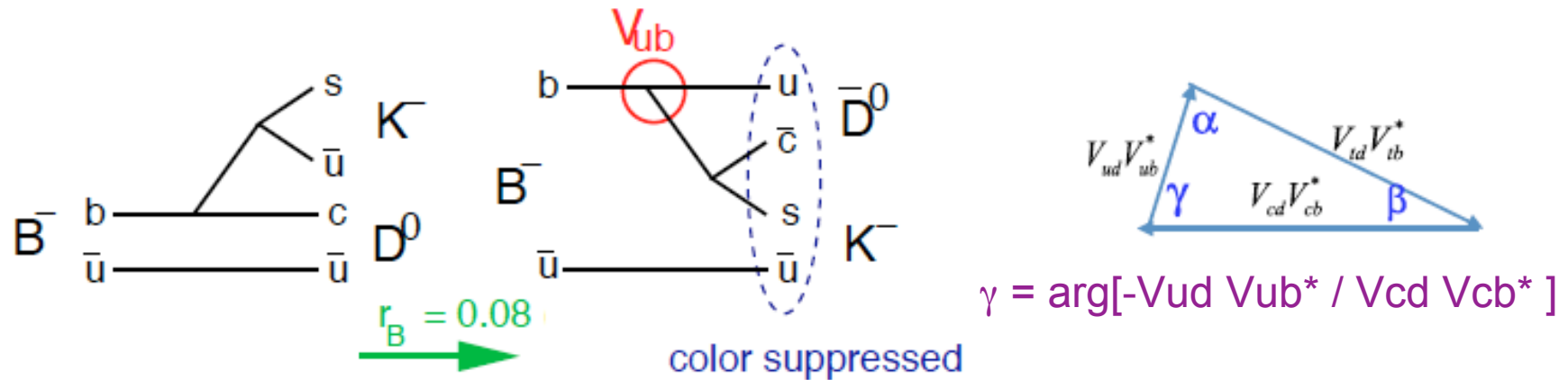

Unknowns:  $r_B$ ,  $\delta_B$ ,  $\gamma$ ,  $r_D$ ,  $\delta_D$  ( $r$  = ratio,  $\delta$  = strong phase)

$B \rightarrow DK$ : final state accessible to both  $D^0$  and  $\bar{D}^0$  mesons, exploiting interference of  $b \rightarrow u\bar{c}s$  and  $b \rightarrow c\bar{u}s$

amplitude ratio between Cabibbo-favoured and suppressed =  $r_B^K$

strong phase difference =  $\delta_B$

Uncertainty on  $\gamma$  scales as  $1/r_B^K$

$B \rightarrow D\pi$ : analogous framework but  $r_B^\pi$  expected to be 1 order of magnitude smaller



# $\gamma$ Measurement with tree decays: $B \rightarrow Dh$

Measurements are classified by their D final state:

- CP eigenstates (GLW) : e.g.  $D \rightarrow K^+ K^-$  ,  $D \rightarrow \pi^+ \pi^-$   
1/fb (2011)

[Phys Lett B 712 (2012) 203][arXiv:1203.3662]

- Flavour eigenstates (ADS) : e.g.  $D \rightarrow K^\pm \pi^\pm \pi^+ \pi^-$ ,  $D \rightarrow K^+ \pi^-$ , ...  
1/fb (2011)

[LHCb-Conf-2012-30]

- Self-conjugate three-body final states (GGSZ) : e.g.  $D \rightarrow K^0_S h^+ h^-$   
1/fb (2011) + 2/fb (2012)

[arXiv:1209.5869] [arXiv:0903.1681]

[LHCb-Conf-2013-06]

[Gronau & London, PLB 253 (1991) 483;  
Gronau & Wyler, PLB 265 (1991) 172;  
Atwood, Duniety & Soni, PRL 78 (1997) 3257;  
Atwood, Duniety & Soni, PRD 63 (2001) 036005]  
Giri, Grossman, Soffer & Zupan, PRD 68 (2003)  
054018;  
Bondar, Proceedings of BINP Special Analysis  
Meeting on Dalitz Analysis, 24-26 Sep. 2002,  
unpublished

# Results

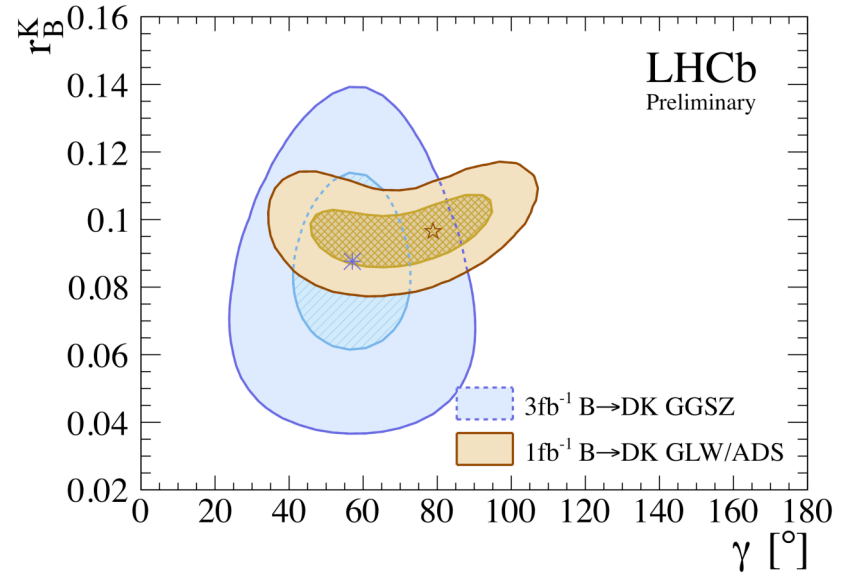
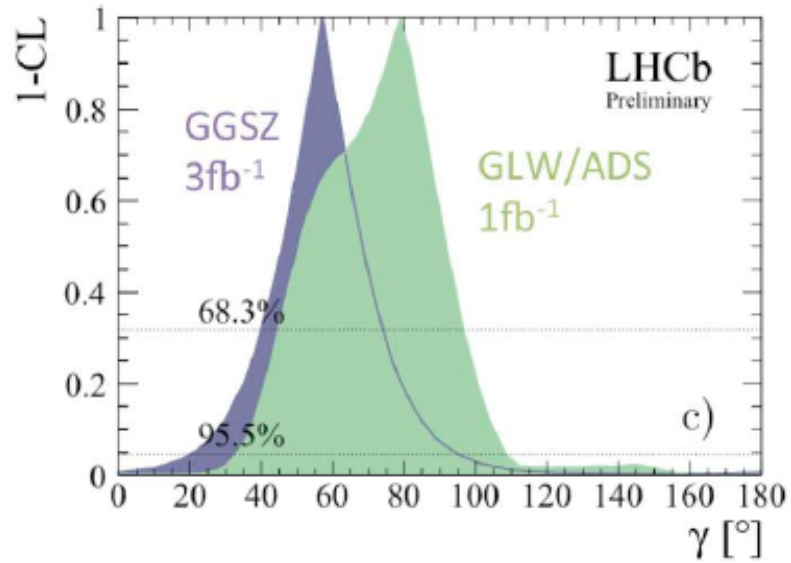

quantity	$DK^\pm$ combination
$\gamma$	$67.2^\circ$
68% CL	$[55.7, 79.6]^\circ$
95% CL	$[44.6, 90.0]^\circ$
$r_B$	0.0924
68% CL	$[0.0847, 0.1004]$
95% CL	$[0.0766, 0.1077]$
$\delta_B$	$114.3^\circ$
68% CL	$[101.7, 126.6]^\circ$
95% CL	$[89.1, 136.5]^\circ$

LHCb result (LHCb-CONF-2013-006)

$$\gamma = (67 \pm 12)^\circ$$

$$\text{Belle: } \gamma = (68_{-14}^{+15})^\circ \quad \text{BaBar: } \gamma = (69_{-16}^{+17})^\circ$$

# Direct CPV in $B^0 \rightarrow K^+ \pi^-$ and $B^0_s \rightarrow \pi^+ K^-$

1.0/fb used (2011 data)

Asymmetry:

$$A_{raw} = \frac{N_{\bar{f}} - N_f}{N_{\bar{f}} + N_f}$$

where  $f = K^+ \pi^- (B^0), \pi^+ K^- (B^0_s)$

**Different heights:  
CPV**

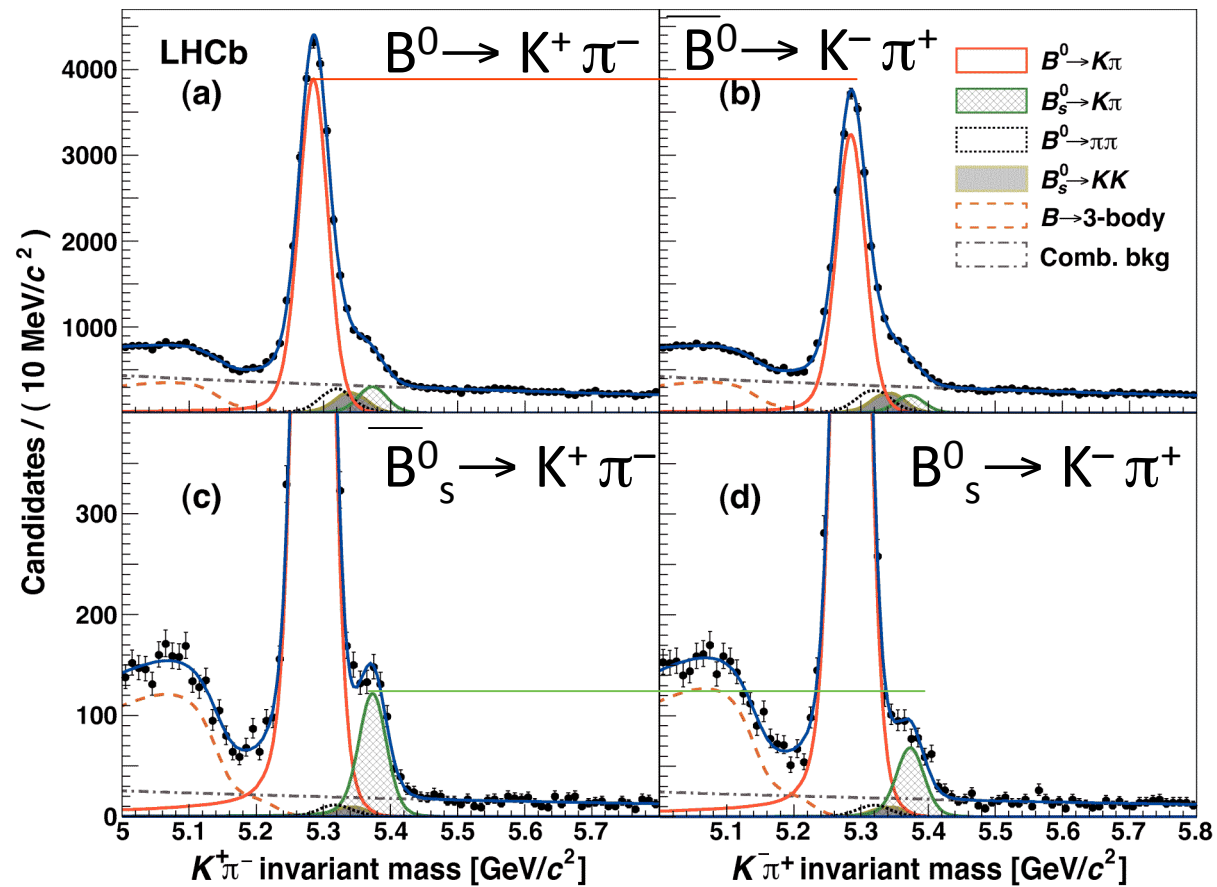

# Direct CPV in $B^0 \rightarrow K^+ \pi^-$ and $B_s^0 \rightarrow \pi^+ K^-$

$$A_{raw}(t) \sim A_{CP} + A_D + A_P \cos(\Delta t)$$

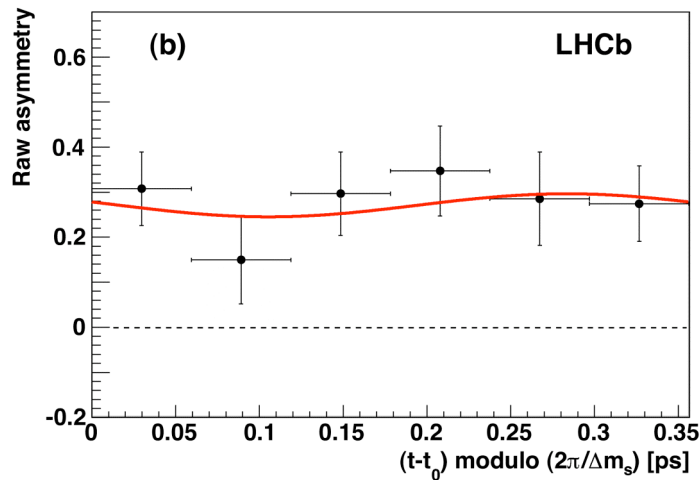

Detection asymmetry corrected using  $D^{*+}$   
 Production asymmetry corrected using time dependence

$$A_{CP}(B^0 \rightarrow K^+ \pi^-) = -0.080 \pm 0.007(stat) \pm 0.003(syst)$$

$$A_{CP}(B_s^0 \rightarrow K^- \pi^+) = 0.27 \pm 0.04(stat) \pm 0.01(syst)$$

PRL 110 (2013) 221601

First observation ( $6.5\sigma$ ) of CPV in  $B_s^0$  decays

Test SM prediction:

$$\Delta = \frac{A_{CP}(B^0 \rightarrow K^+ \pi^-)}{A_{CP}(B_s^0 \rightarrow K^- \pi^+)} + \frac{B(B_s^0 \rightarrow K^- \pi^+) \tau_d}{B(B^0 \rightarrow K^+ \pi^-) \tau_s} = 0$$

From measurements:

$$\Delta = -0.02 \pm 0.05 \pm 0.04$$

Cristina Lazzeroni

# $B_s$ events

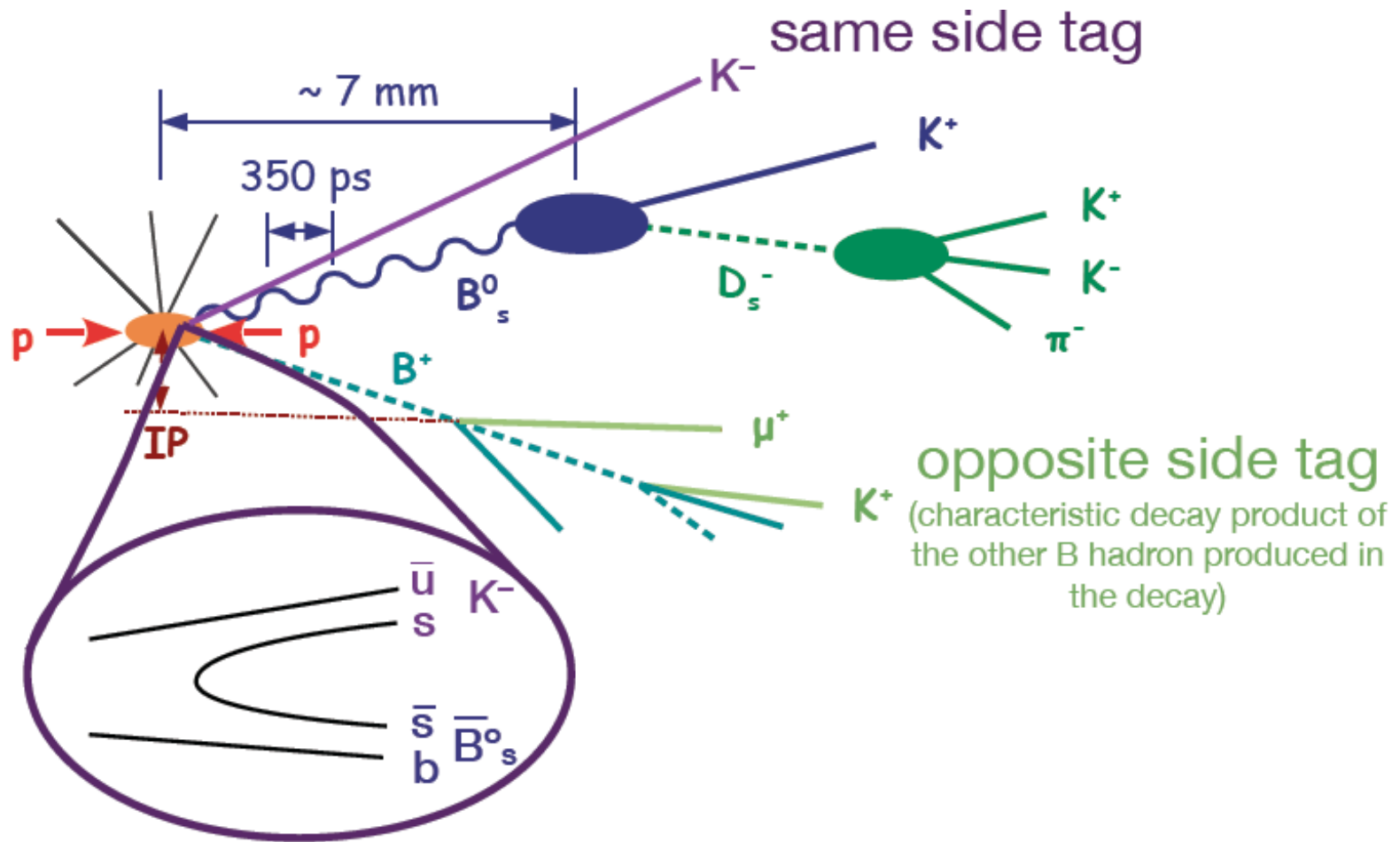

# $B_s - \bar{B}_s$ oscillations

Flavour eigenstate  $\neq$  mass eigenstate

Flavour eigenstates  $B_s, \bar{B}_s$

Two mass eigenstates with mass  $m_H$  and  $m_L$  and width  $\Gamma_H$  and  $\Gamma_L$

5 parameters:  $m, \Gamma, \Delta\Gamma, \Delta m_s, \phi_s$

Oscillation frequency  $\Delta m_s = m_H - m_L$

Phase  $\phi_s = \text{CP violating phase of the above diagram relative to decay diagram}$

Reconstructed  $\sim 34,000$  tagged

$B_s^0 \rightarrow D_s^- \pi^+$  candidates in 1.0/fb (2011 data)

$D_s^-$  reconstructed in 5 decay modes:  $D_s^- \rightarrow \phi \pi^-$ ,  
 $D_s^- \rightarrow K^{0*} K^-$ ,  $D_s^- \rightarrow K^+ K^- \pi^-$ ,  $D_s^- \rightarrow K^- \pi^+ \pi^-$ ,  
 $D_s^- \rightarrow \pi^+ \pi^- \pi^-$

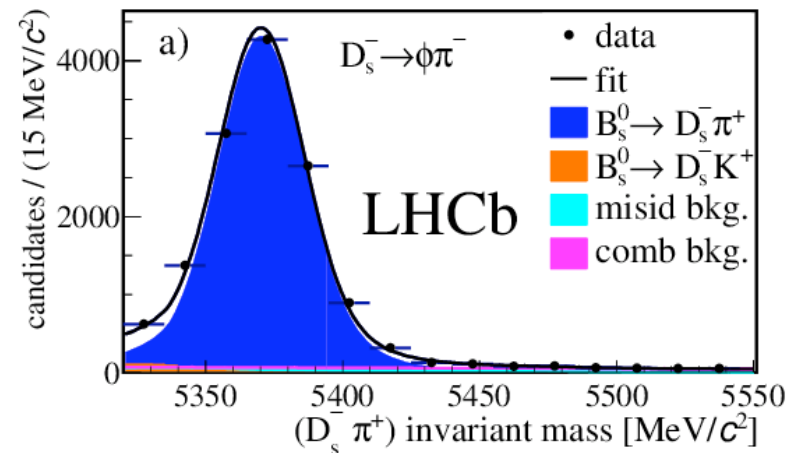
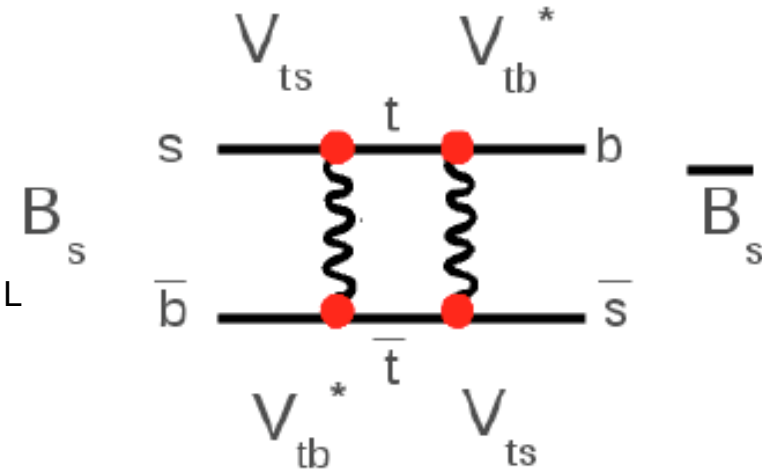

# Measurement of $\Delta m_s$

Measurement of modulation in decay time distribution for mixed and unmixed

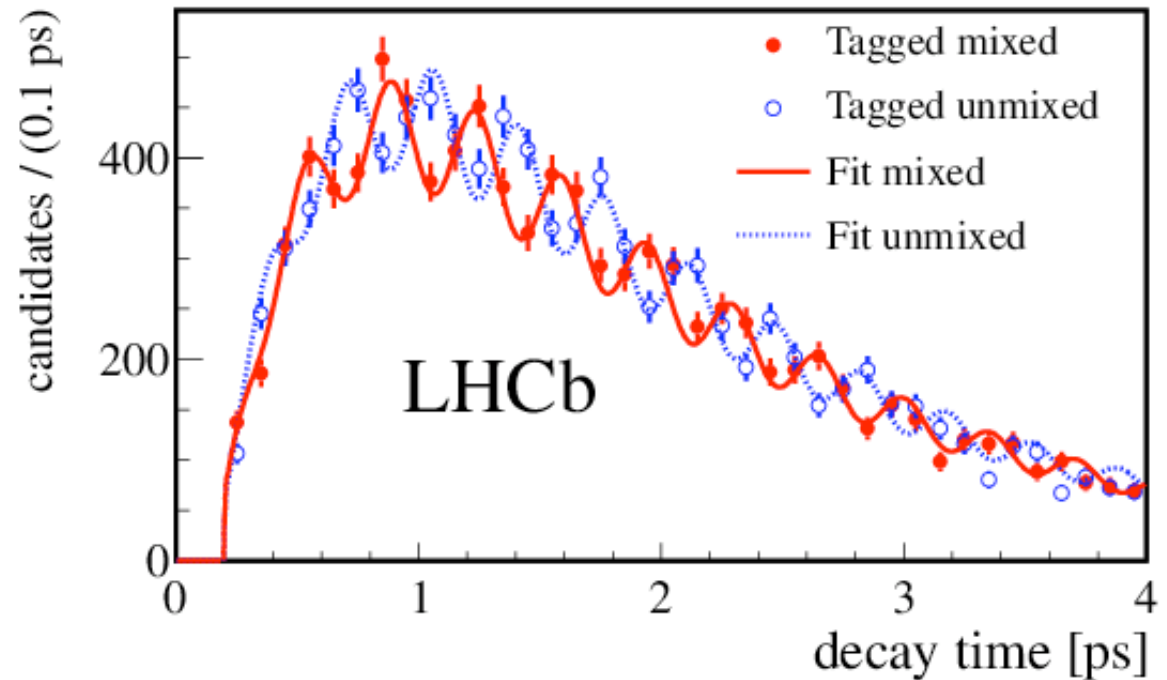

$\Delta m_s = 17.768 \pm 0.023(\text{stat.}) \pm 0.006(\text{syst.})/\text{ps}$  World's best measurement

New J. Phys. 15 (2013) 053021

Main syst. uncertainties from distance and momentum scale

# $\phi_s$ from $B_s^0 \rightarrow J/\psi h^+h^-$ decays ( $h=\pi,K$ )

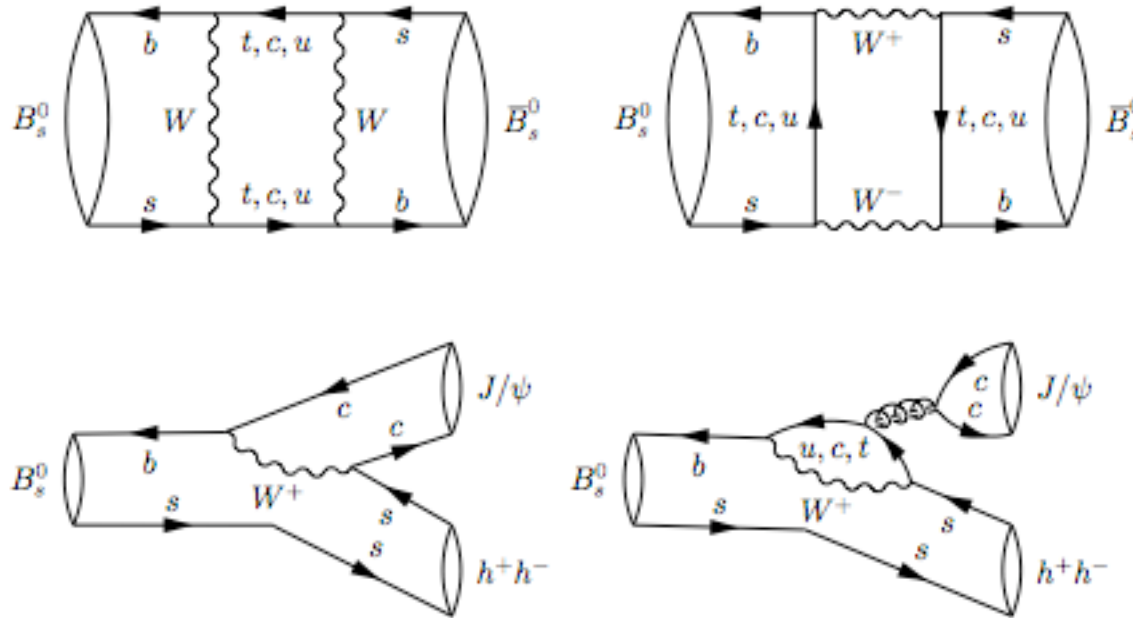

Access to phase  $\phi_s$  via interference between mixing+direct decay and direct decay into CP eigenstate

In SM  $\phi_s \approx -2\arg(-V_{ts}V_{tb}^* / V_{cs}V_{cb}^*) \sim$  phase of  $V_{ts}$   
 $\phi_s = -0.0364 \pm 0.0016$  rad

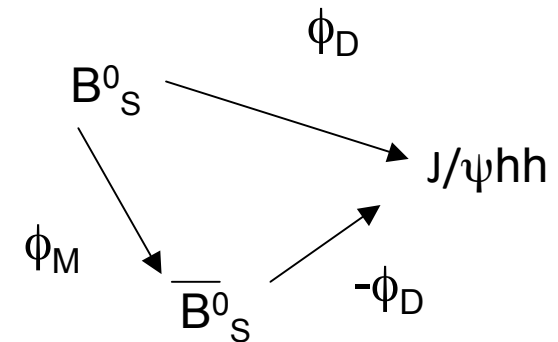

New physics in box and/or penguin diagrams



# CP states in $B_s^0 \rightarrow J/\psi h^+ h^-$

- $B_s^0 \rightarrow J/\psi \phi(1020) : P \rightarrow VV$ , CP admixture  
Angular analysis required with 3 amplitudes:  
 $A_0, A_{||}$  (CP-even),  $A_{\perp}$  (CP-odd)

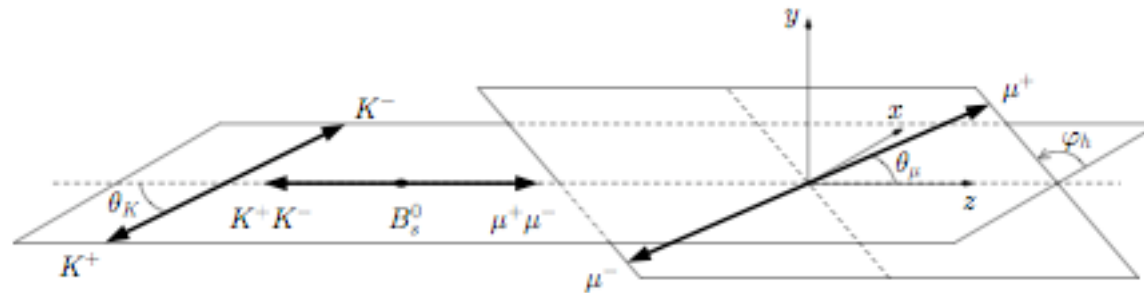

- $B_s^0 \rightarrow J/\psi K^+K^-$  non resonant: S-wave  $\rightarrow$  CP-odd  
One amplitude  $A_S$

$B_s^0 \rightarrow J/\psi \pi^+ \pi^-$  is pure CP-odd (>97.7% @ 95% CL )

No angular analysis needed [Phys.Rev D86 (2012) 052006]

# $B_s^0 \rightarrow J/\psi h^+ h^-$ signals

Phys.Rev.D87(2013)112010

27,600  $B_s^0 \rightarrow J/\psi K^+ K^-$  in 1.0/fb (2011 data)

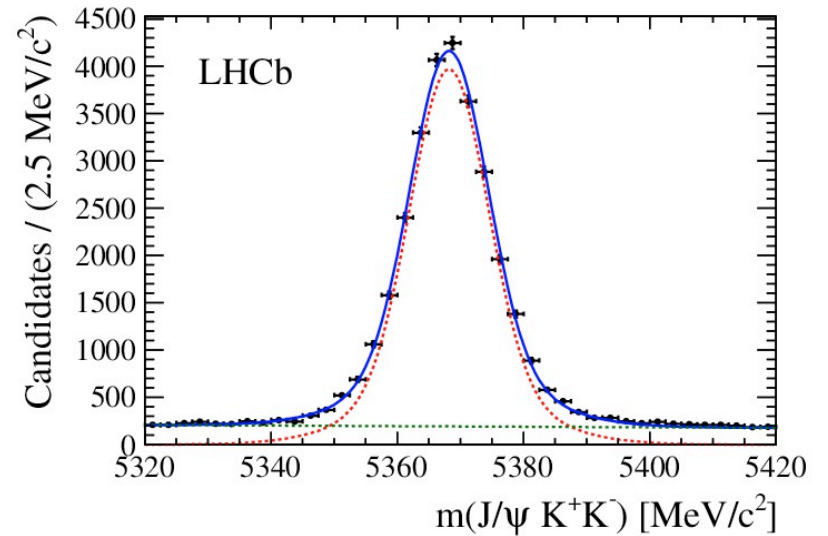

7,400  $B_s^0 \rightarrow J/\psi \pi^+ \pi^-$  in 1.0/fb (2011 data)

[Phys. Lett. B713 (2012) 378–386]

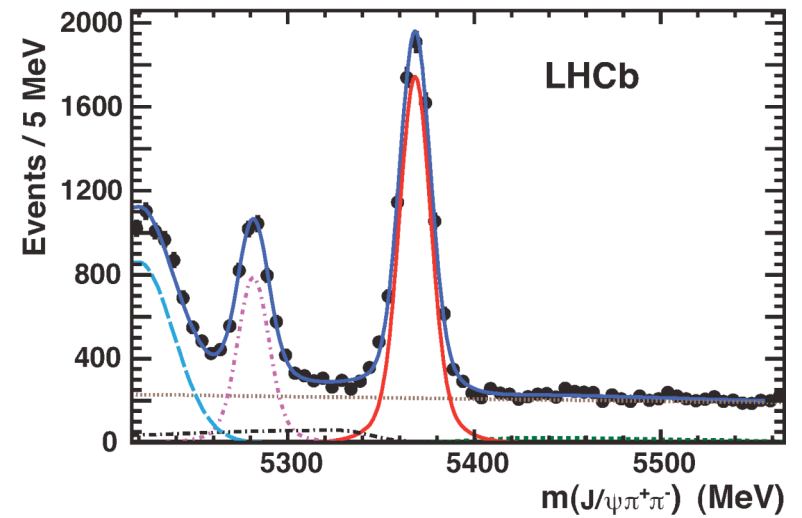

# $B_s^0 \rightarrow J/\psi h^+h^-$ results combined

Combined fit of  $B_s^0 \rightarrow J/\psi K^+K^-$  and  $B_s^0 \rightarrow J/\psi \pi^+\pi^-$

$$\phi_s = 0.01 \pm 0.07 \text{ (stat)} \pm 0.01 \text{ (syst)} \text{ rad}$$

$$\Gamma_s = 0.661 \pm 0.004 \text{ (stat)} \pm 0.006 \text{ (syst)} \text{ ps}^{-1}$$

$$\Delta\Gamma_s = 0.106 \pm 0.011 \text{ (stat)} \pm 0.007 \text{ (syst)} \text{ ps}^{-1}$$

**World's best measurement**

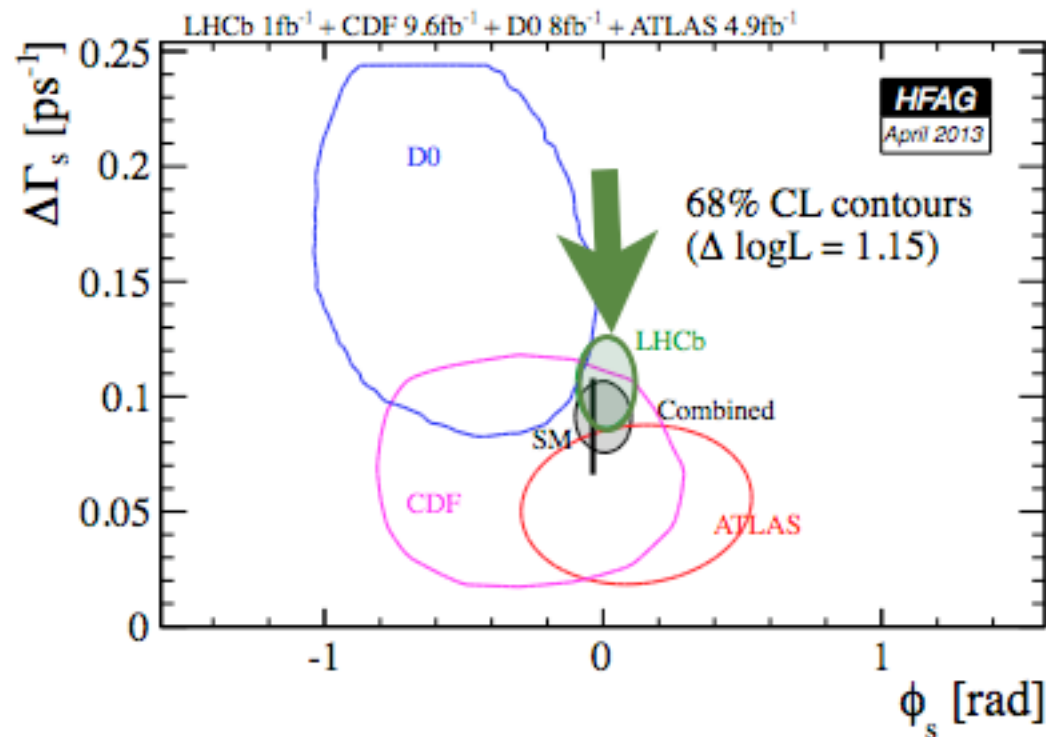

Phys.Rev.D87(2013)112010

Supersedes previous results:

Phys Rev Lett 108 (2012) 101803

Physics Letters B 713 (2012) 378

$$B_s^0 \rightarrow \mu^+ \mu^-$$

- Suppressed by FCNC and helicity
- **Precise SM branching fraction expectations** [arXiv:1208.0934] :

$$B(B_s^0 \rightarrow \mu^+ \mu^-) = (3.35 \pm 0.28) \times 10^{-9}$$

$$B(B^0 \rightarrow \mu^+ \mu^-) = (1.07 \pm 0.10) \times 10^{-10}$$

- **Calculable at 10% level**
- **Possible modified Branching ratio due to range of NP models:** extended Higgs models; new scalar, pseudoscalar and axial-vectors; SUSY

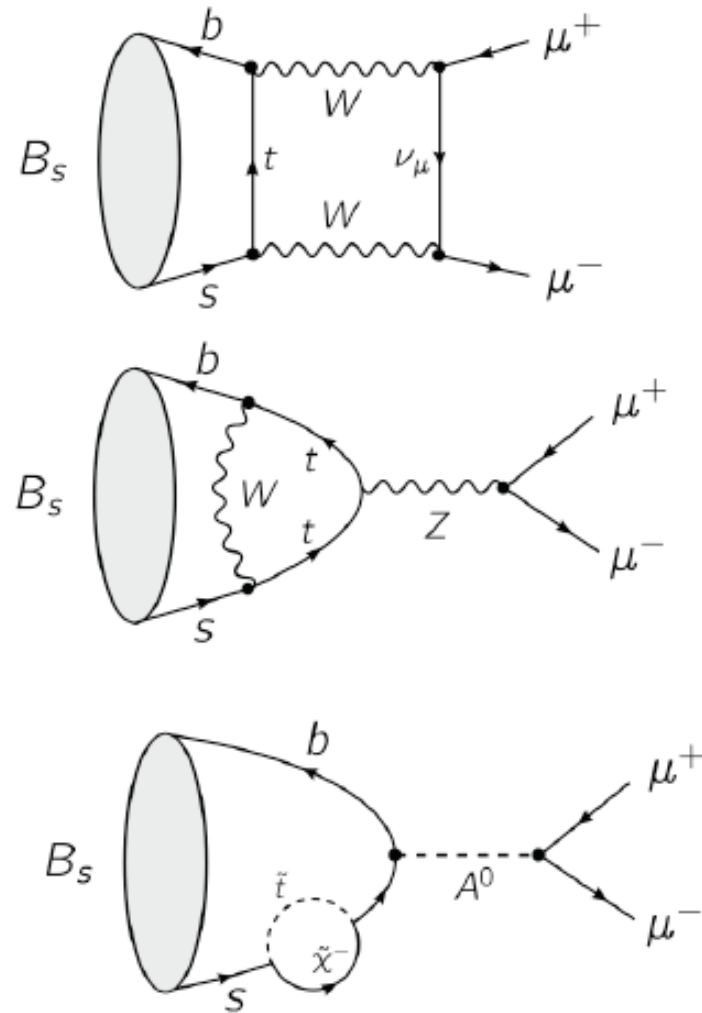

# $B^0_{(s)} \rightarrow \mu^+\mu^-$ results

- Blind analysis on 3/fb of data recorded in 2011 and 2012
- Large background: excellent PID
- Selection based on mass and Boosted Decision Tree (BDT)
- BDT: kinematic and geometrical variables, trained with MC calibrated on data

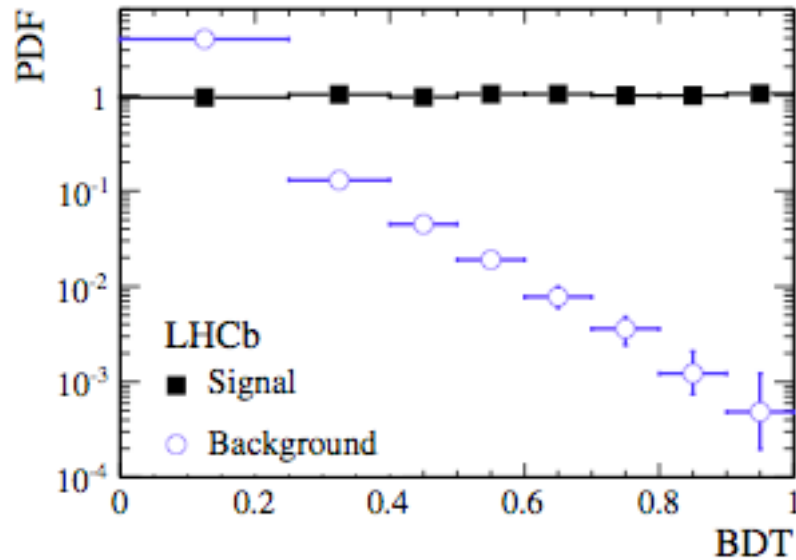

For BDT > 0.7

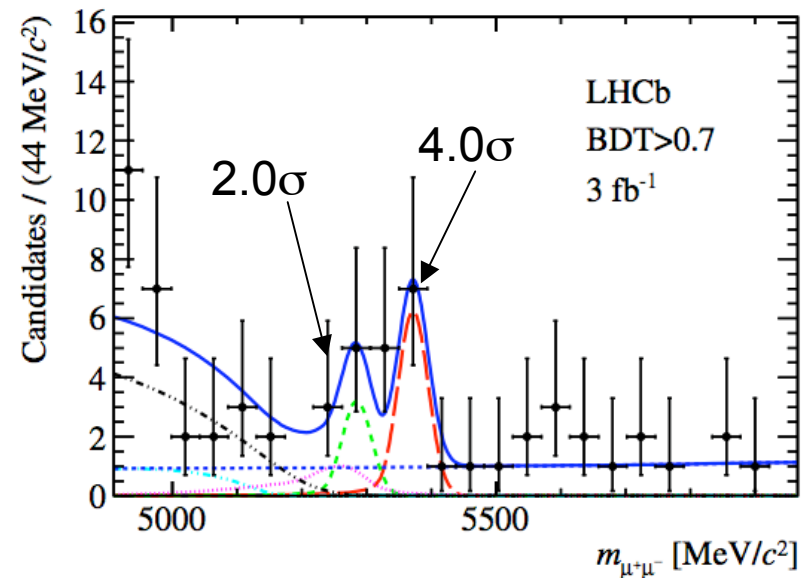

arXiv:1307.5024

# Implications of $B_{(s)}^0 \rightarrow \mu^+\mu^-$ results

**LHCb:**

$$B(B_s^0 \rightarrow \mu^+\mu^-) = (2.9_{-1.0}^{+1.1}(\text{stat})_{-0.1}^{+0.3}(\text{syst})) \times 10^{-9}$$

$$B(B^0 \rightarrow \mu^+\mu^-) = (3.7_{-2.1}^{+2.4}(\text{stat})_{-0.4}^{+0.6}(\text{syst})) \times 10^{-10}$$

SM:  $B(B_s^0 \rightarrow \mu^+\mu^-) = (3.35 \pm 0.28) \times 10^{-9}$

$B(B^0 \rightarrow \mu^+\mu^-) = (1.07 \pm 0.10) \times 10^{-10}$

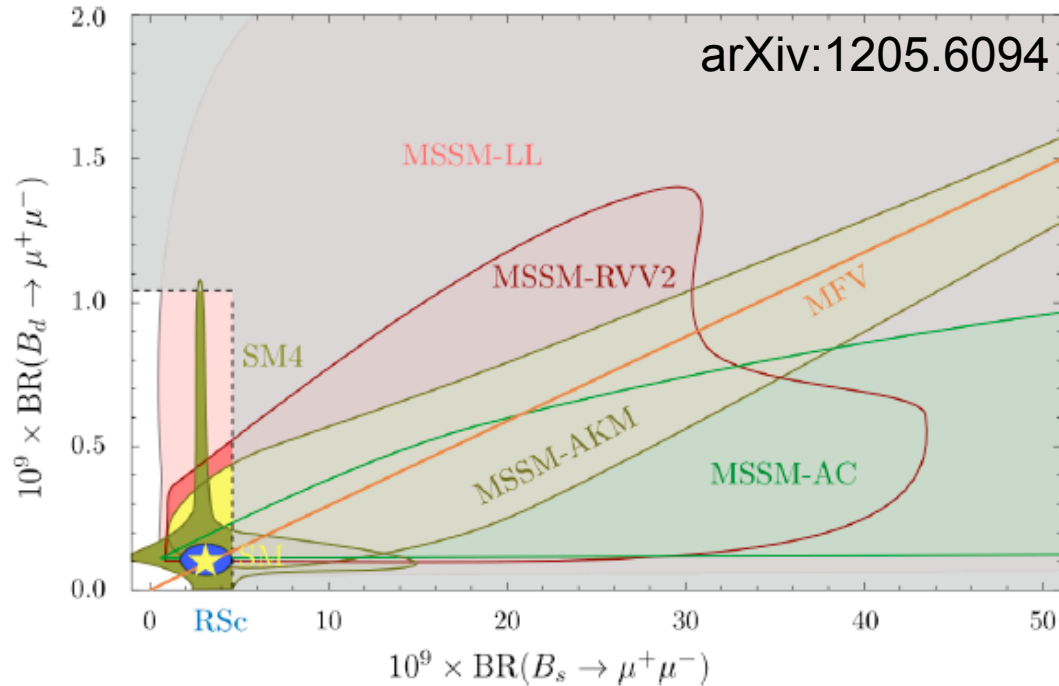

The grey area is ruled out experimentally

$$B^0 \rightarrow K^{*0}(K^+\pi^-)\mu^+\mu^-$$

Rare decay in SM ( $BR \sim 10^{-6}$ )

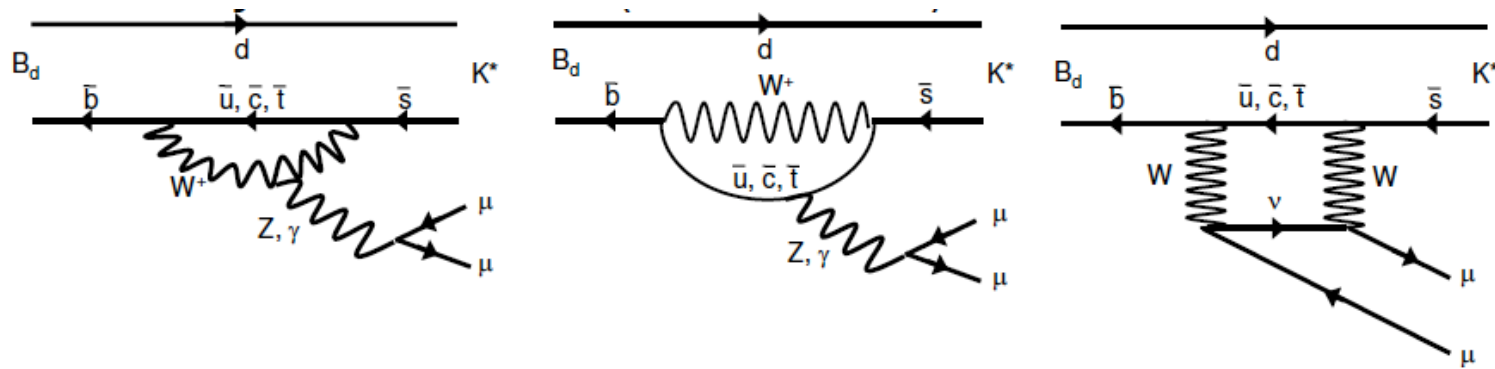

Sensitive to New Physics in loops, e.g.

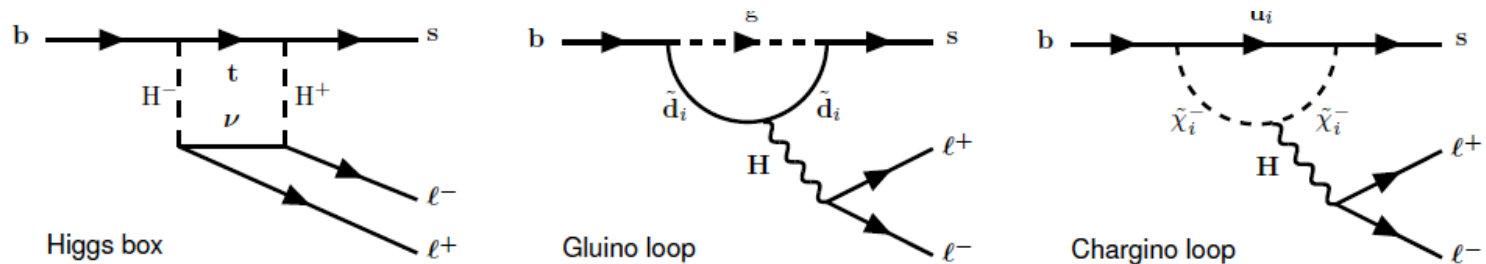

# Observables in $B^0 \rightarrow K^{*0}(K^+\pi^-)\mu^+\mu^-$

## Angular observables, rates and asymmetries

Decay rate described by equations below

Large number of NP-sensitive parameters,  
accessible through careful analysis of decay  
kinematics

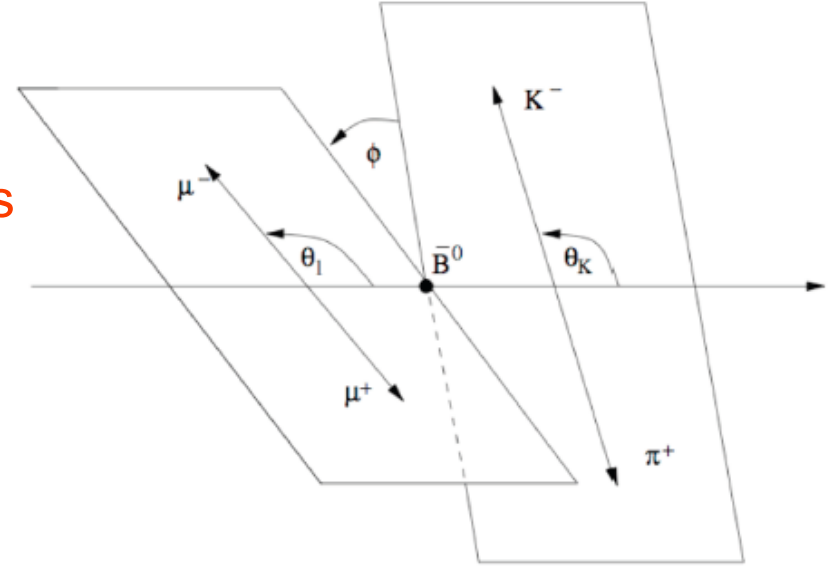

$$\frac{1}{\Gamma} \frac{d^3(\Gamma + \bar{\Gamma})}{d \cos \theta_\ell d \cos \theta_K d \phi} = \frac{9}{32\pi} \left[ \frac{3}{4}(1 - F_L) \sin^2 \theta_K + F_L \cos^2 \theta_K + \frac{1}{4}(1 - F_L) \sin^2 \theta_K \cos 2\theta_\ell \right. \\ \left. - F_L \cos^2 \theta_K \cos 2\theta_\ell + S_3 \sin^2 \theta_K \sin^2 \theta_\ell \cos 2\phi \right. \\ \left. + S_4 \sin 2\theta_K \sin 2\theta_\ell \cos \phi + S_5 \sin 2\theta_K \sin \theta_\ell \cos \phi \right. \\ \left. + S_6 \sin^2 \theta_K \cos \theta_\ell + S_7 \sin 2\theta_K \sin \theta_\ell \sin \phi \right. \\ \left. + S_8 \sin 2\theta_K \sin 2\theta_\ell \sin \phi + S_9 \sin^2 \theta_K \sin^2 \theta_\ell \sin 2\phi \right]$$



# Forward-backward asymmetry in $B^0 \rightarrow K^{*0}(K^+\pi^-)\mu^+\mu^-$

Forward:

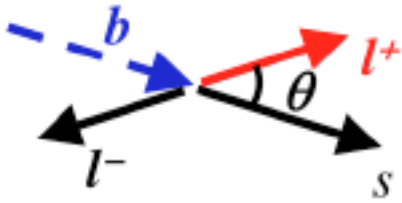

Backward:

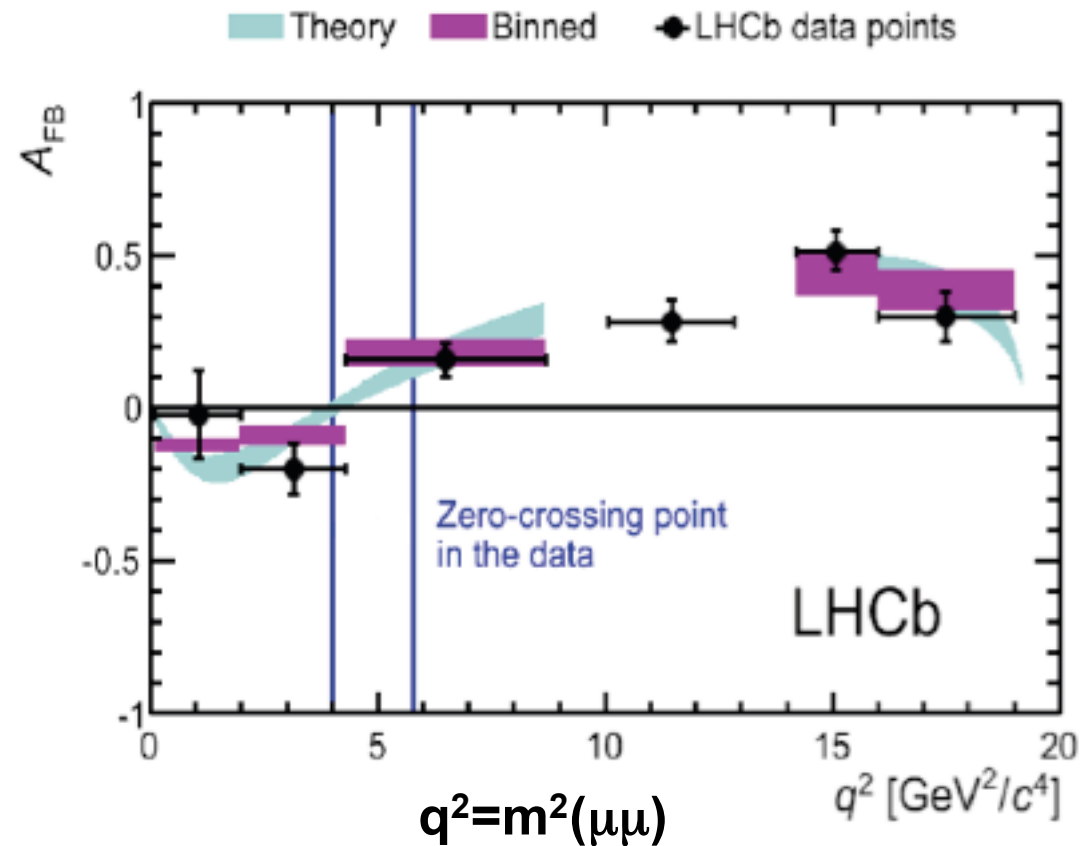
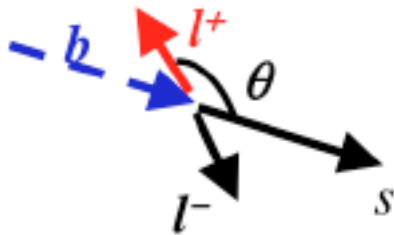

Good agreement with SM

First measurement of zero-crossing point:  $q_0^2 = 4.9 \pm 0.9 \text{ GeV}^2/c^4$

# New observables in $B^0 \rightarrow K^{*0}(K^+\pi^-)\mu^+\mu^-$

Observables with decreased dependence on form factor uncertainty:

arXiv:1106.3283, arXiv:1202.4266  
 arXiv:hep-ph/0502060, arXiv:0807.2589,  
 arXiv:1105.0376, arXiv:1303.5794

$$A_T^{(2)} = \frac{2S_3}{(1-F_L)} A_T^{Re} = \frac{S_6}{(1-F_L)}$$

$$P'_4 = \frac{S_4}{\sqrt{(1-F_L)F_L}} \quad P'_5 = \frac{S_5}{\sqrt{(1-F_L)F_L}}$$

$$P'_6 = \frac{S_7}{\sqrt{(1-F_L)F_L}} \quad P'_8 = \frac{S_8}{\sqrt{(1-F_L)F_L}}$$

Use following folding  $\phi \rightarrow -\phi$  (if  $\phi < 0$ ) and  $\theta_l \rightarrow \pi - \theta_l$  (if  $\theta_l < \pi/2$ ) to measure  $P'_5$ :

$$\frac{1}{\bar{\Gamma}} \frac{d^3(\Gamma + \bar{\Gamma})}{d \cos \theta_\ell d \cos \theta_K d \phi} = \frac{9}{8\pi} \left[ \frac{3}{4}(1-F_L) \sin^2 \theta_K + F_L \cos^2 \theta_K + \frac{1}{4}(1-F_L) \sin^2 \theta_K \cos 2\theta_\ell \right. \\
\left. - F_L \cos^2 \theta_K \cos 2\theta_\ell + \frac{1}{2}(1-F_L) A_T^{(2)} \sin^2 \theta_K \sin^2 \theta_\ell \cos 2\phi \right. \\
\left. + \sqrt{F_L(1-F_L)} P'_5 \sin 2\theta_K \sin \theta_\ell \cos \phi \right]$$

Transformations for  $P'_{4,6,8}$  are similar

# Results: $P'_4$ , $P'_6$ , $P'_8$

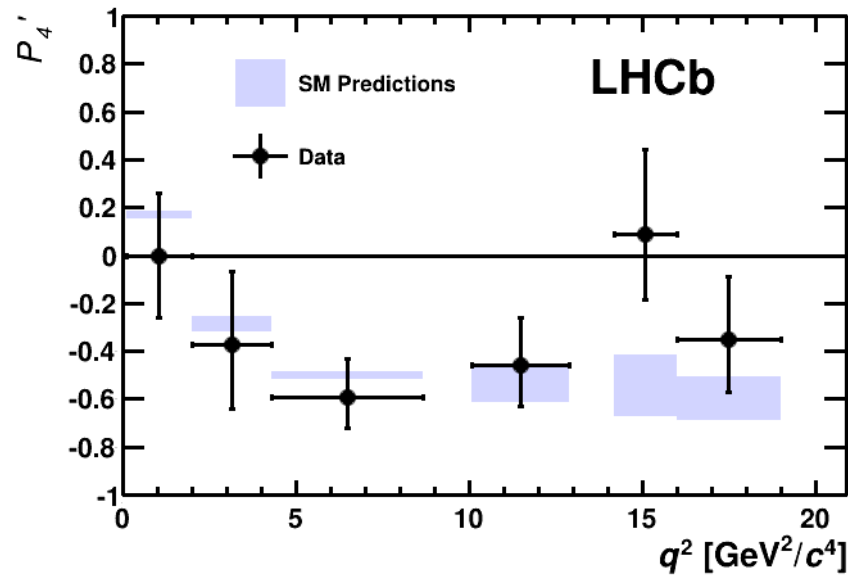

Analysis using 1/fb of data recorded in 2011

Results in good agreement with SM

LHCb-PAPER-2013-037, arXiv:1308.1707

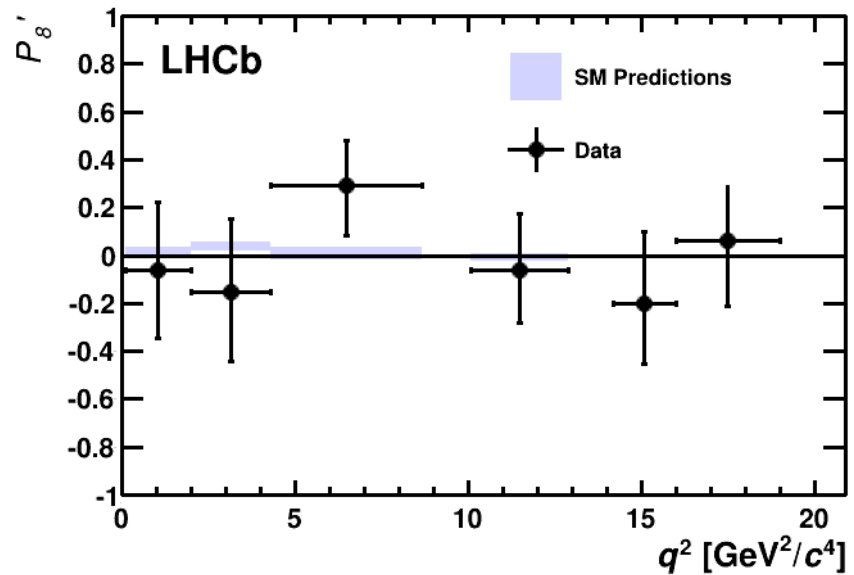
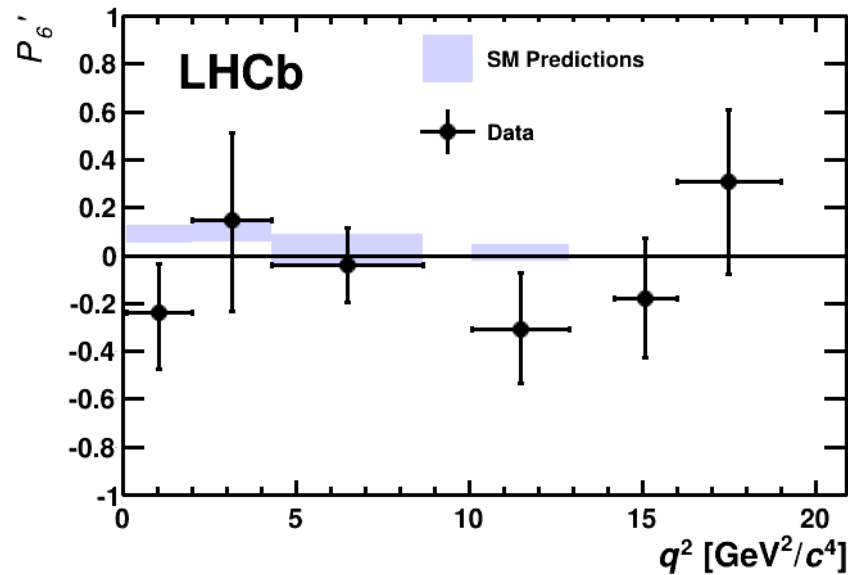

# Results: $P'_5$

3.7 $\sigma$  local discrepancy in the region  
 $4.3 < q^2 < 8.68 \text{ GeV}^2/c^4$

0.5% probability to observe such a deviation considering the 24 independent measurements (several other variables probed, each in several bins of  $q^2$ )

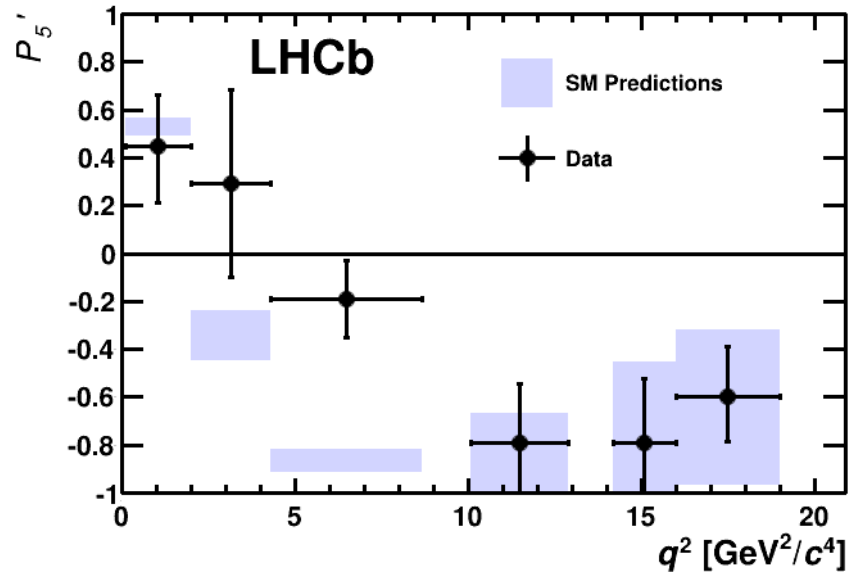

Recently S.Descotes-Genon, J.Matias, J.Virto suggested that combining this with other flavour observables, the observed discrepancy in  $P'_5$  could be caused by a smaller value of the Wilson coefficient  $C_9$  w.r.t SM [arXiv:1308.5683]

Other theorists suggest a flavour changing  $Z'$  gauge boson as a possible explanation

# Summary

Flavour physics is sensitive to new physics at very high mass scales, looking at quantum loops

LHCb is the most sensitive heavy flavour experiment  
So far, constraints on many NP models

Results confirm the SM....

Only discrepancy seen with  $P'_5$  in  $B^0 \rightarrow K^{*0} \mu^+ \mu^-$

This is just the beginning - most of data already taken have still to be analyzed, and most of data have yet to be taken, after LHC shutdown and in LHCb-upgrade

# Spares

# B events at LHCb

K,  $\pi$ ,  $\mu$  final states

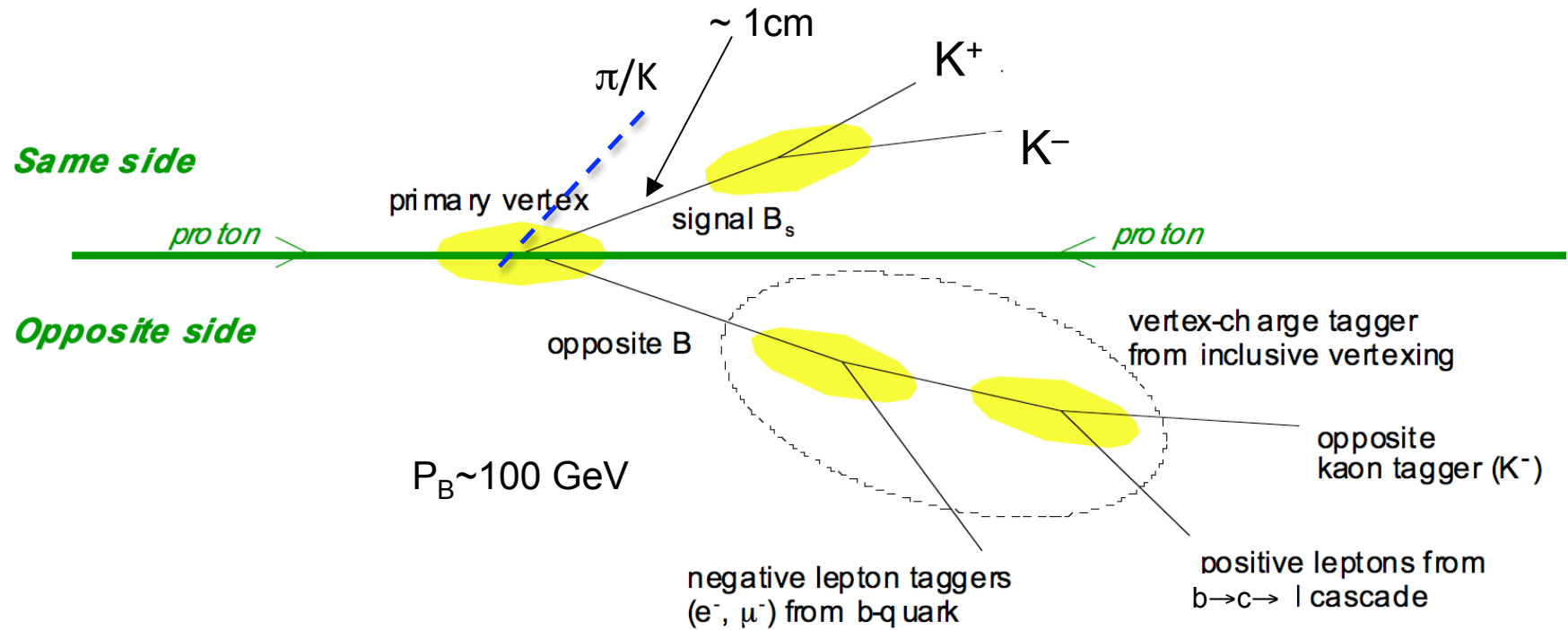

# $B^0_{(s)} \rightarrow \mu^+\mu^-$ results

- Blind analysis on 3/fb of data recorded in 2011 and 2012
- Large background: excellent PID
- Selection based on mass and Boosted Decision Tree (BDT)
- BDT: kinematic and geometrical variables, trained with MC calibrated on data

$$B(B_s^0 \rightarrow \mu^+\mu^-) = (2.9_{-1.0}^{+1.1}(\text{stat})_{-0.1}^{+0.3}(\text{syst})) \times 10^{-9}$$

Significance:  $4.0\sigma$

$$B(B^0 \rightarrow \mu^+\mu^-) = (3.7_{-2.1}^{+2.4}(\text{stat})_{-0.4}^{+0.6}(\text{syst})) \times 10^{-10}$$

Significance:  $2.0\sigma$

For BDT > 0.7

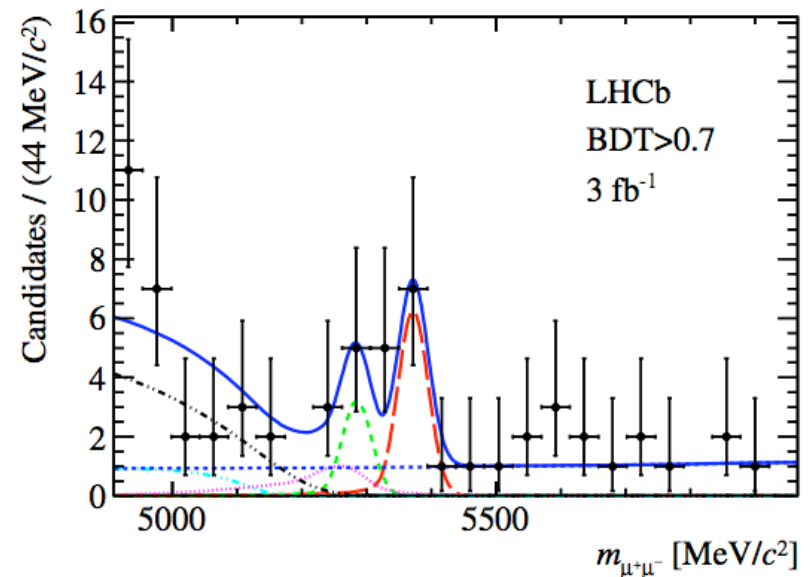

arXiv:1307.5024