

QCD Phenomenology at High Energy

Bryan Webber

CERN Academic Training Lectures 2008

Lecture 4: Jet Fragmentation and Hadron-Hadron Processes

- Jet Fragmentation
 - ❖ Fragmentation functions
 - ❖ Small- x fragmentation
 - ❖ Average multiplicity
- Hadronization Models
 - ❖ General ideas
 - ❖ Cluster model
 - ❖ String model
- Hadron-Hadron Processes
 - ❖ Parton-parton luminosities
 - ❖ Lepton pair, jet and heavy quark production
 - ❖ Higgs boson production
- Survey of NLO Calculations for LHC

Jet Fragmentation

- **Fragmentation functions** $F_i^h(x, t)$ gives distribution of momentum fraction x for hadrons of type h in a jet initiated by a parton of type i , produced in a hard process at scale t .
- Like parton distributions in a hadron, $D_i^h(x, t)$, these are **factorizable** quantities, in which infrared divergences of PT can be factorized out and replaced by experimentally measured factor that contains all long-distance effects.
- In e^+e^- annihilation, for example, the hard process is $e^+e^- \rightarrow q\bar{q}$ at scale equal to c.m. energy squared s ; distribution of $x = 2p_h/\sqrt{s}$ is (for $s \ll M_Z^2$)

$$\frac{d\sigma}{dx} = 3\sigma_0 \sum_q Q_q^2 \left\{ F_q^h(x, s) + F_{\bar{q}}^h(x, s) \right\}$$

where σ_0 is $e^+e^- \rightarrow \mu^+\mu^-$ cross section.

- Fragmentation functions satisfy DGLAP evolution equation

$$t \frac{\partial}{\partial t} F_i^h(x, t) = \sum_j \int_x^1 \frac{dz}{z} \frac{\alpha_S}{2\pi} P_{ji}(z, \alpha_S) F_j^h(x/z, t) .$$

Splitting functions P_{ji} have perturbative expansions of the form

$$P_{ji}(z, \alpha_S) = P_{ji}^{(0)}(z) + \frac{\alpha_S}{2\pi} P_{ji}^{(1)}(z) + \dots$$

Leading terms $P_{ji}^{(0)}(z)$ were given earlier. Notice that splitting function is P_{ji} rather than P_{ij} since F_j^h represents fragmentation of final parton j .

- Solve DGLAP equation by taking moments as explained for DIS. As in that case, **scaling violation** is clearly seen.

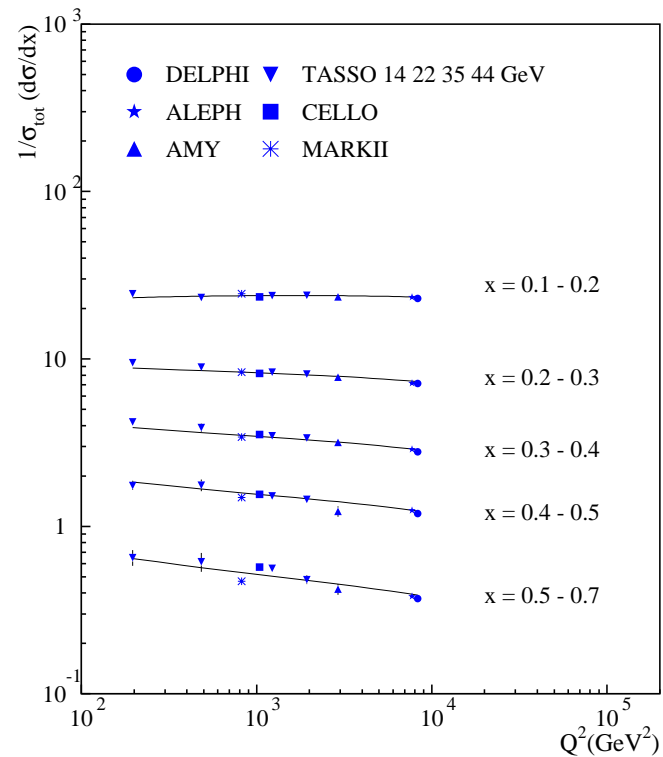
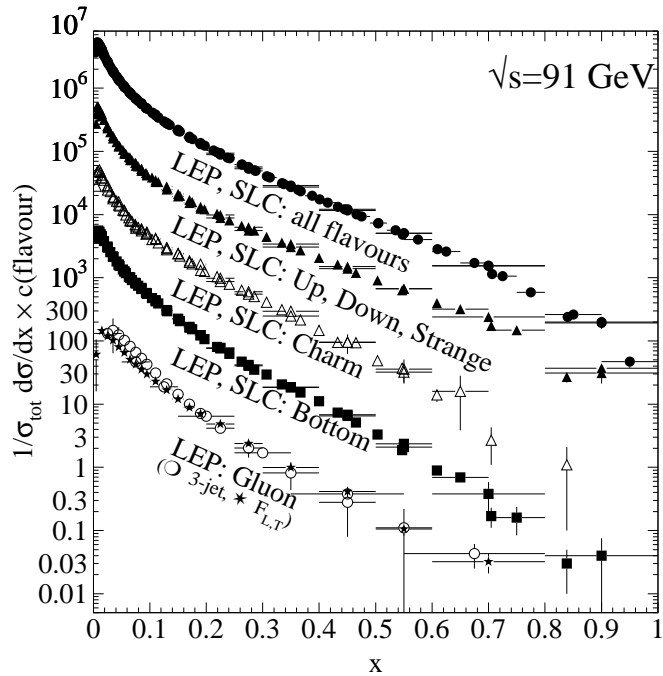

Small- x fragmentation

- Evolution of fragmentation functions at small x sensitive to moments near $N = 1$. However, anomalous dimensions $\gamma_{gq}^{(0)}$, $\gamma_{gg}^{(0)}$ are not defined at $N = 1$: moment integrals for $N \leq 1$ are dominated by small z , where $P_{gi}(z)$ diverges due to soft gluon emission.
- At small z must take into account **coherence effects**. Recall evolution variable becomes $\tilde{t} = E^2[1 - \cos \theta]$, with angular ordering condition $\tilde{t}' < z^2 \tilde{t}$. Thus, redefining t as \tilde{t} , evolution equation in integrated form is

$$F_i(x, t) = F_i(x, t_0) + \sum_j \int_x^1 \frac{dz}{z} \int_{t_0}^{z^2 t} \frac{dt'}{t'} \frac{\alpha_S}{2\pi} P_{ji}(z) F_j(x/z, t')$$

or in differential form

$$t \frac{\partial}{\partial t} F_i(x, t) = \sum_j \int_x^1 \frac{dz}{z} \frac{\alpha_S}{2\pi} P_{ji}(z) F_j(x/z, z^2 t) .$$

- Only difference from DGLAP equation is z -dependent scale on the right-hand side — not important for most values of x but crucial at small x .
- For simplicity, consider first α_S fixed and neglect sum over j . Taking moments as usual,

$$t \frac{\partial}{\partial t} \tilde{F}(N, t) = \frac{\alpha_S}{2\pi} \int_x^1 dz z^{N-1} P(z) \tilde{F}(N, z^2 t) .$$

- ❖ Try solution of form $F(N, t) \propto t^{\gamma(N, \alpha_S)}$. Then anomalous dimension $\gamma(N, \alpha_S)$ must satisfy

$$\gamma(N, \alpha_S) = \frac{\alpha_S}{2\pi} \int_0^1 z^{N-1+2\gamma(N, \alpha_S)} P(z) .$$

- ❖ For $N - 1$ not small, we can neglect $2\gamma(N, \alpha_S)$ in exponent and obtain usual formula for anomalous dimension. For $N \simeq 1$, $z \rightarrow 0$ region dominates, where $P_{gg}(z) \simeq 2C_A/z$. Hence

$$\begin{aligned} \gamma_{gg}(N, \alpha_S) &= \frac{C_A \alpha_S}{\pi} \frac{1}{N - 1 + 2\gamma_{gg}(N, \alpha_S)} \\ &= \frac{1}{4} \left[\sqrt{(N - 1)^2 + \frac{8C_A \alpha_S}{\pi}} - (N - 1) \right] \\ &= \sqrt{\frac{C_A \alpha_S}{2\pi}} - \frac{1}{4}(N - 1) + \frac{1}{32} \sqrt{\frac{2\pi}{C_A \alpha_S}} (N - 1)^2 + \dots \end{aligned}$$

- To take account of running α_S , write

$$\tilde{F}(N, t) \sim \exp \left[\int^t \gamma_{gg}(N, \alpha_S) \frac{dt'}{t'} \right] ,$$

and note that $\gamma_{gg}(N, \alpha_S)$ should be $\gamma_{gg}(N, \alpha_S(t'))$. Use

$$\int^t \gamma_{gg}(N, \alpha_S(t')) \frac{dt'}{t'} = \int^{\alpha_S(t)} \frac{\gamma_{gg}(N, \alpha_S)}{\beta(\alpha_S)} d\alpha_S ,$$

where $\beta(\alpha_S) = -b\alpha_S^2 + \dots$, to find

$$\begin{aligned} \tilde{F}(N, t) \sim & \exp \left[\frac{1}{b} \sqrt{\frac{2C_A}{\pi\alpha_S}} - \frac{1}{4b\alpha_S} (N-1) \right. \\ & \left. + \frac{1}{48b} \sqrt{\frac{2\pi}{C_A\alpha_S^3}} (N-1)^2 + \dots \right]_{\alpha_S=\alpha_S(t)} . \end{aligned}$$

- In e^+e^- annihilation, scale $t \sim s$ and behaviour of $\tilde{F}(N, s)$ near $N = 1$ determines form of small- x fragmentation functions. Keeping terms up to $(N-1)^2$ in exponent gives Gaussian function of N which transforms into Gaussian function of $\xi \equiv \ln(1/x)$:

$$xF(x, s) \propto \exp \left[-\frac{1}{2\sigma^2} (\xi - \xi_p)^2 \right] ,$$

● Width of distribution

$$\sigma = \left(\frac{1}{24b} \sqrt{\frac{2\pi}{C_A \alpha_S^3(s)}} \right)^{\frac{1}{2}} \propto (\ln s)^{\frac{3}{4}} .$$

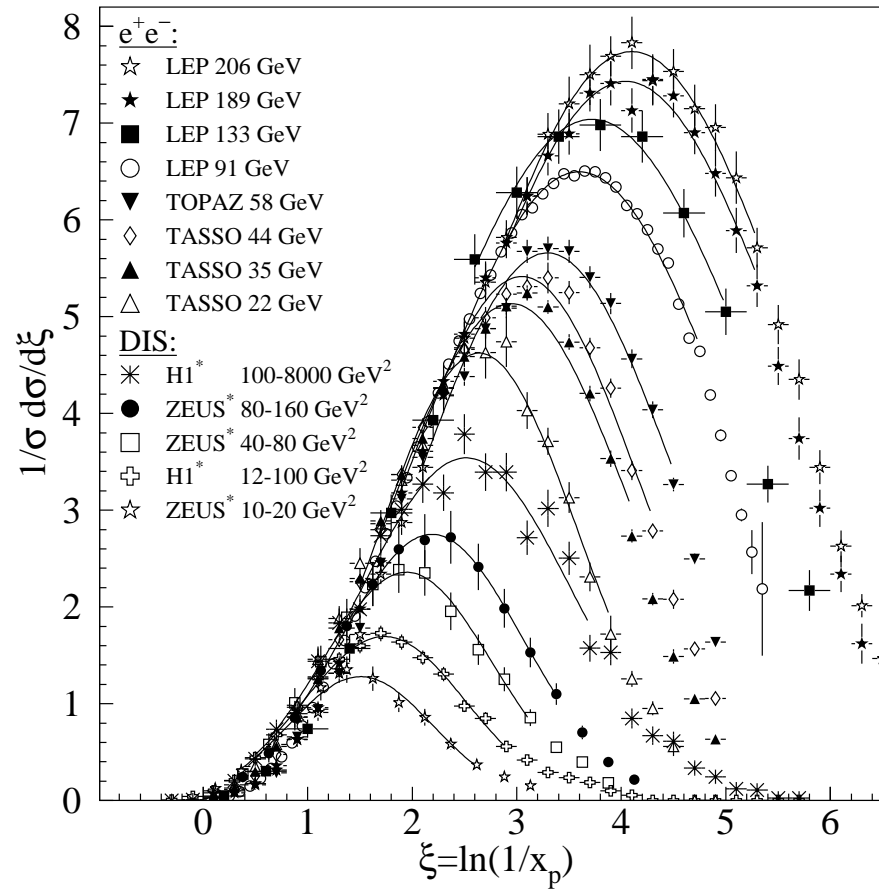

- Peak position

$$\xi_p = \frac{1}{4b\alpha_s(s)} \sim \frac{1}{4} \ln s$$

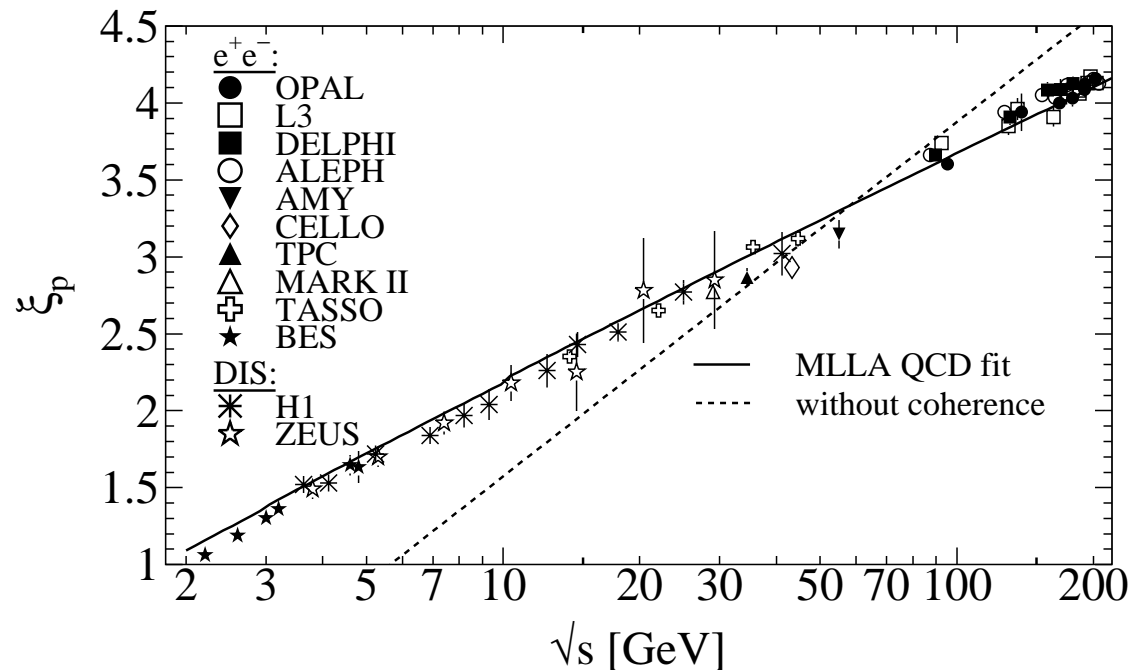

- Energy-dependence of the peak position ξ_p tests suppression of hadron production at small x due to soft gluon coherence. Decrease at very small x is expected on kinematical grounds, but this would occur at particle energies proportional to their masses, i.e. at $x \propto m/\sqrt{s}$, giving $\xi_p \sim \frac{1}{2} \ln s$. Thus purely kinematic suppression would give ξ_p increasing **twice as fast**.
- In $p\bar{p} \rightarrow$ dijets, \sqrt{s} is replaced by $M_{JJ} \sin \theta$ where M_{JJ} is dijet mass and θ is jet cone angle.

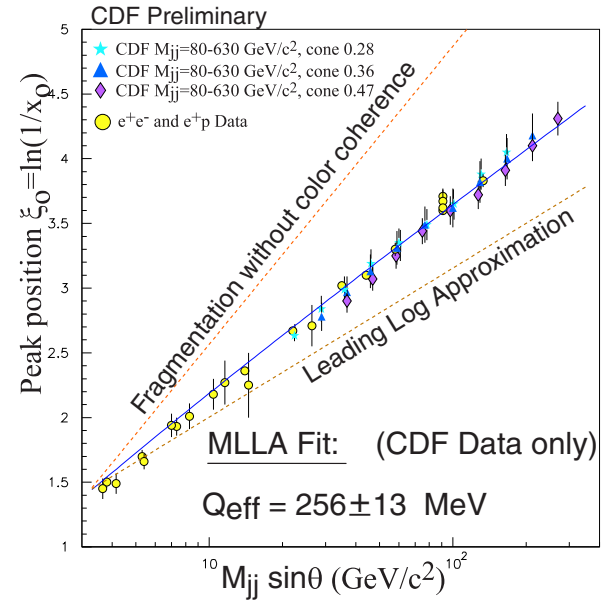
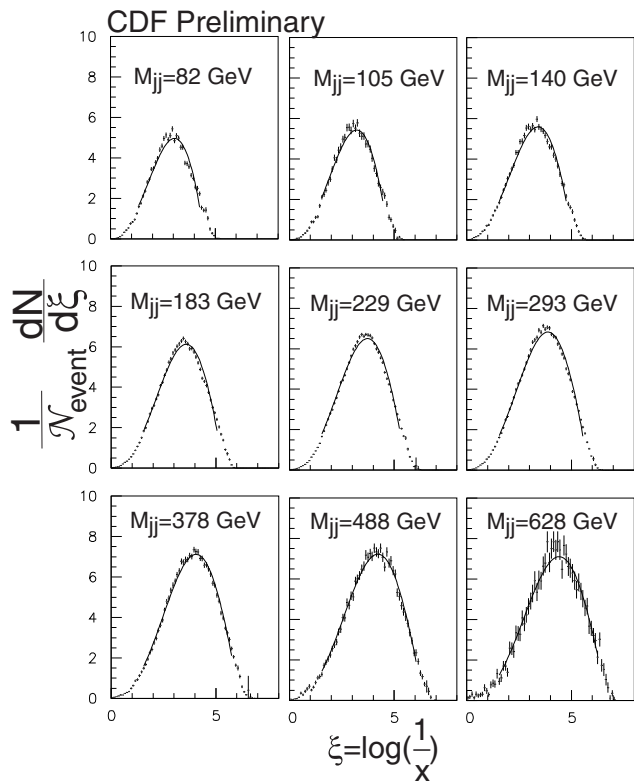
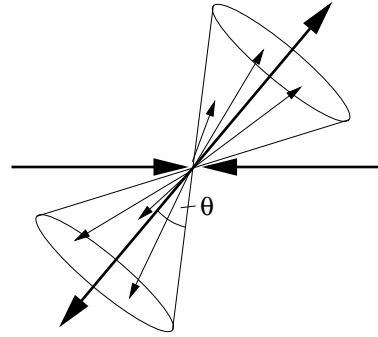

Average Multiplicity

- Mean number of hadrons is $N = 1$ moment of fragmentation function:

$$\langle n(s) \rangle = \int_0^1 dx F(x, s) = \tilde{F}(1, s)$$
$$\sim \exp \frac{1}{b} \sqrt{\frac{2C_A}{\pi\alpha_S(s)}} \sim \exp \sqrt{\frac{2C_A}{\pi b} \ln \left(\frac{s}{\Lambda^2} \right)}$$

(plus NLL corrections) in good agreement with data.

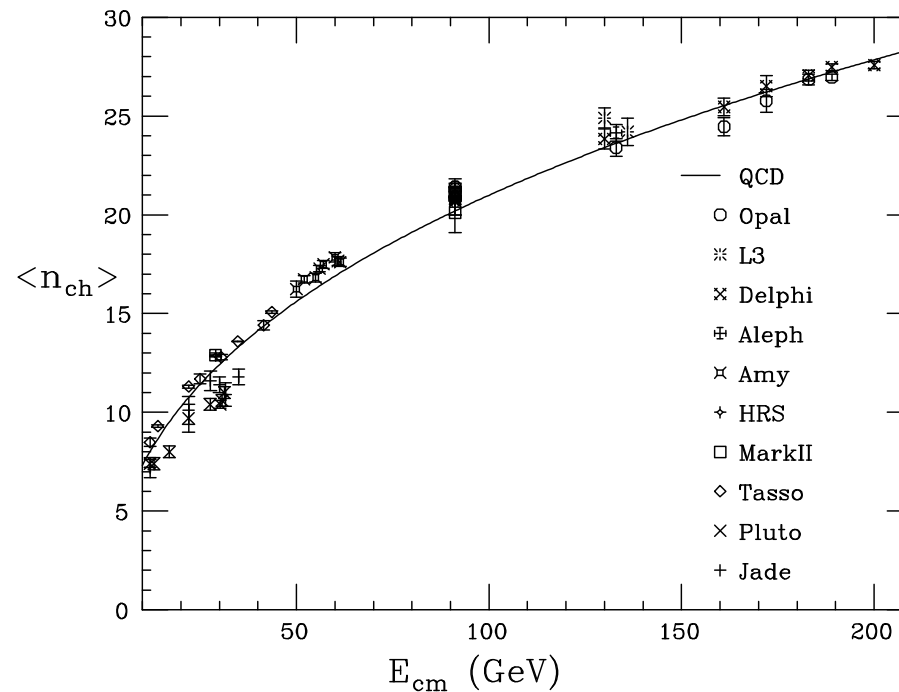

Hadronization Models

General ideas

- Local parton-hadron duality
 - ❖ Hadronization is long-distance process, involving small momentum transfers.
Hence hadron-level flow of energy-momentum, flavour should follow parton level.
 - ❖ Results on spectra and multiplicities support this.
- Universal low-scale α_S
 - ❖ PT works well down to very low scales, $Q \sim 1$ GeV.
 - ❖ Assume $\alpha_S(Q)$ defined (non-perturbatively) for all Q .
 - ❖ Good description of heavy quark spectra, event shapes.

Specific models

- General ideas do not describe hadron formation. Main current models are **cluster** and **string**.

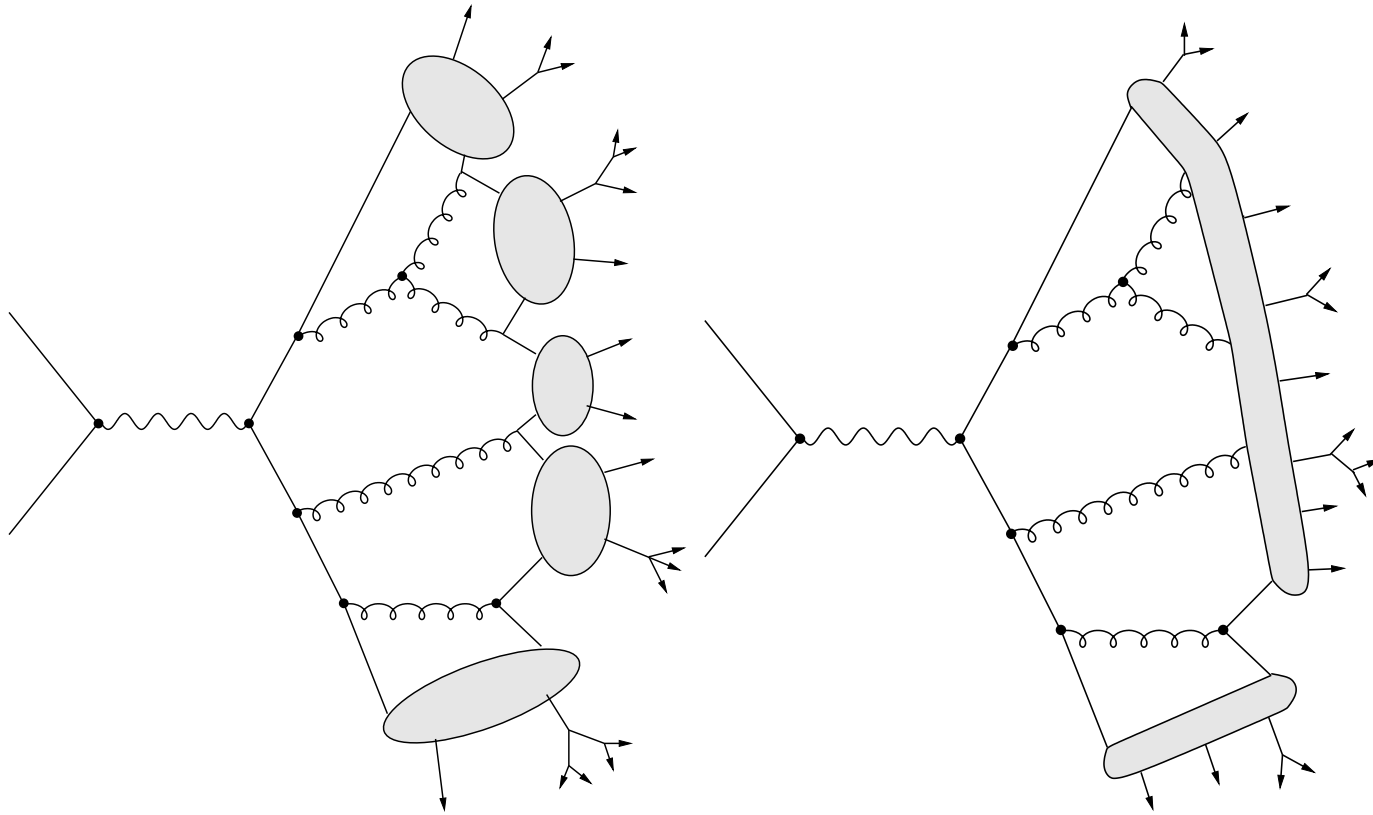

- Cluster (HERWIG)

- ❖ Non-perturbative $g \rightarrow q\bar{q}$ splitting after parton shower.
- ❖ Colour singlet $q\bar{q}$ clusters have lower mass due to **preconfinement** property of parton shower.

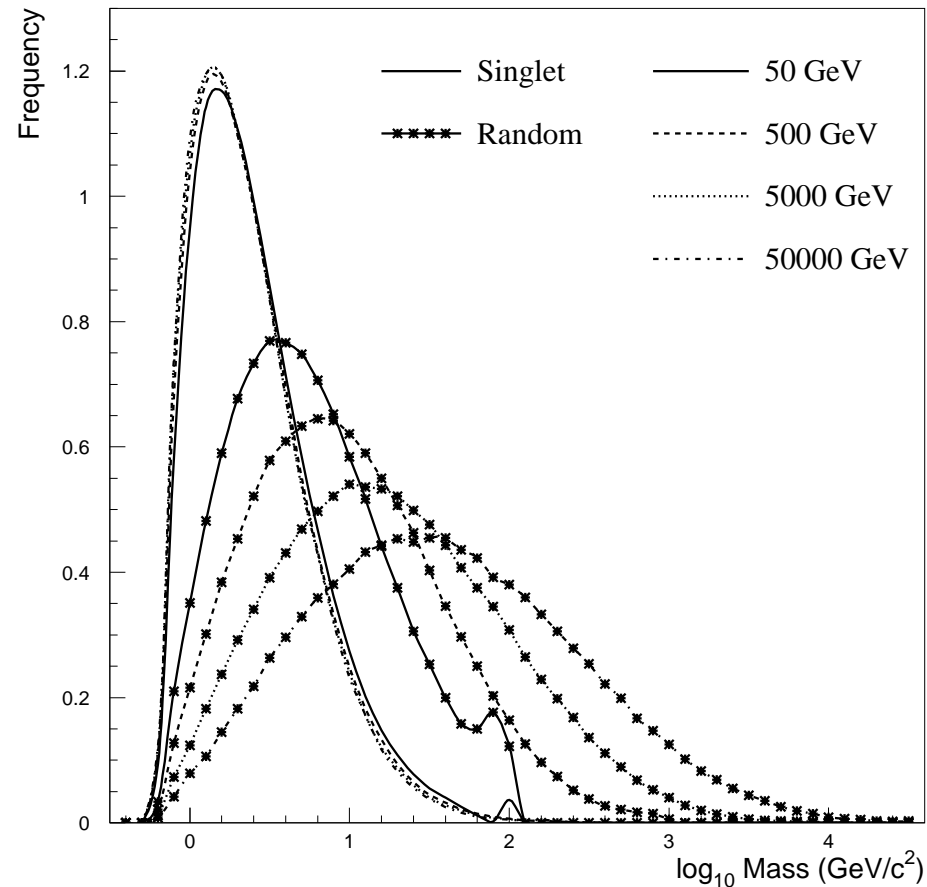

- ❖ Clusters decay according to 2-hadron density of states.
- ❖ Few parameters: natural p_T and heavy particle suppression
- ❖ Problems with massive clusters, baryons, heavy quarks

- String (PYTHIA)

- ❖ Uses **string dynamics**: colour string stretched between initial $q\bar{q}$ breaks up into hadrons via $q\bar{q}$ pair production.
- ❖ String gives linear confinement potential, area law for matrix elements.
- ❖ Gluons produced in shower give 'kinks' on string.

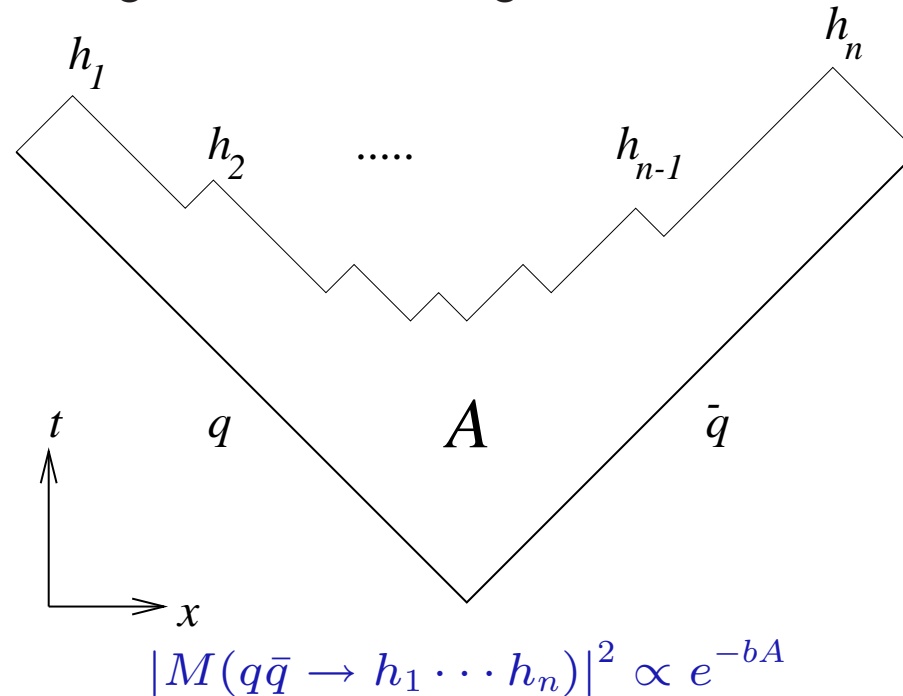

- ❖ Extra parameters for p_T and heavy particle suppression.
 - ❖ Some problems with baryons.
- Both models describe e^+e^- data well . . .

● Jet rates and mean number of jets

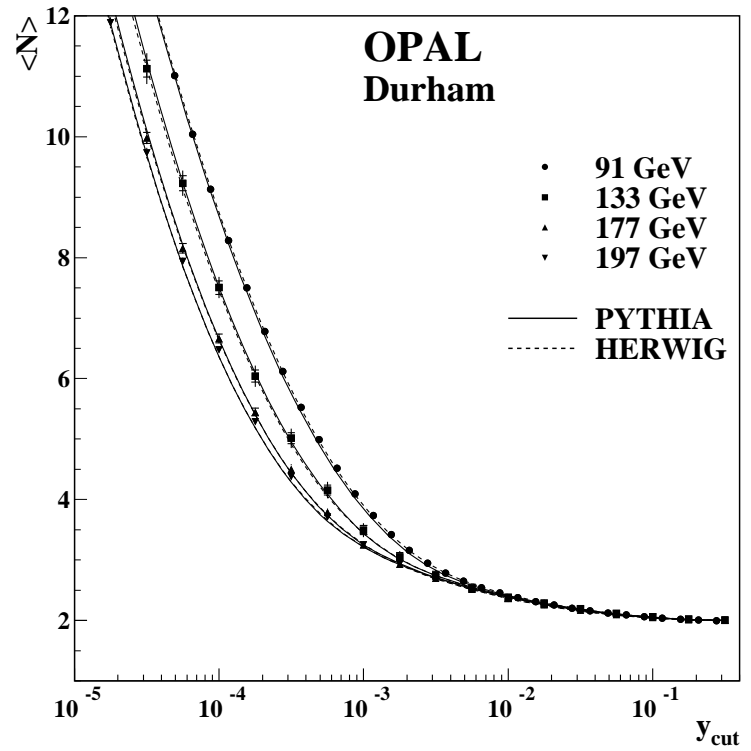
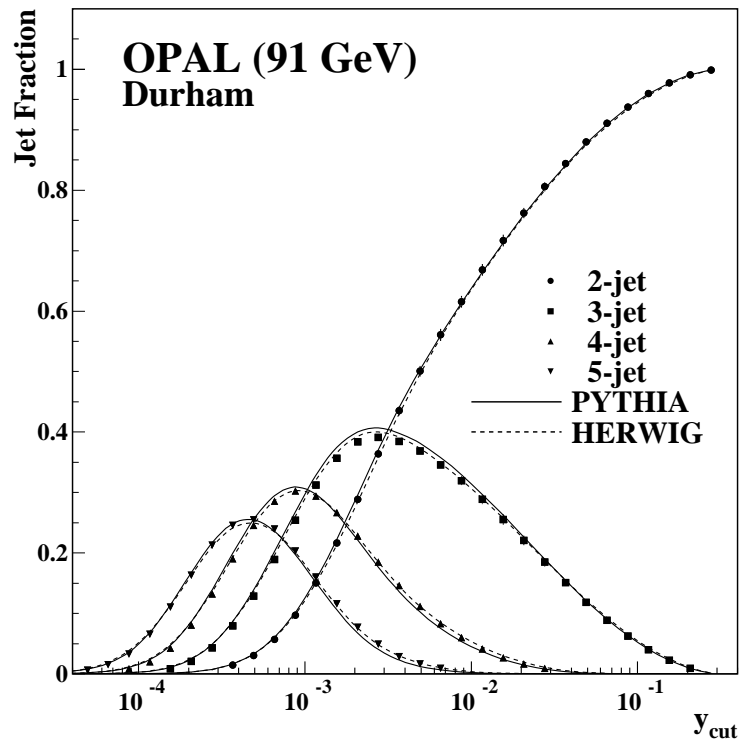

● Light quark and gluon fragmentation functions

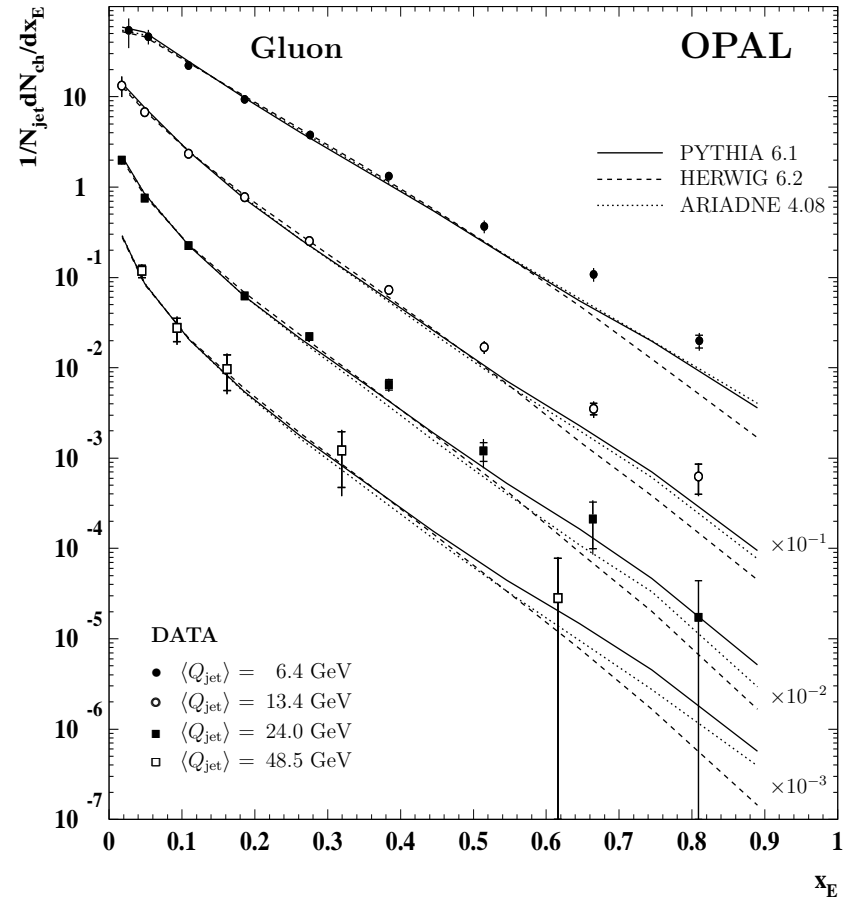
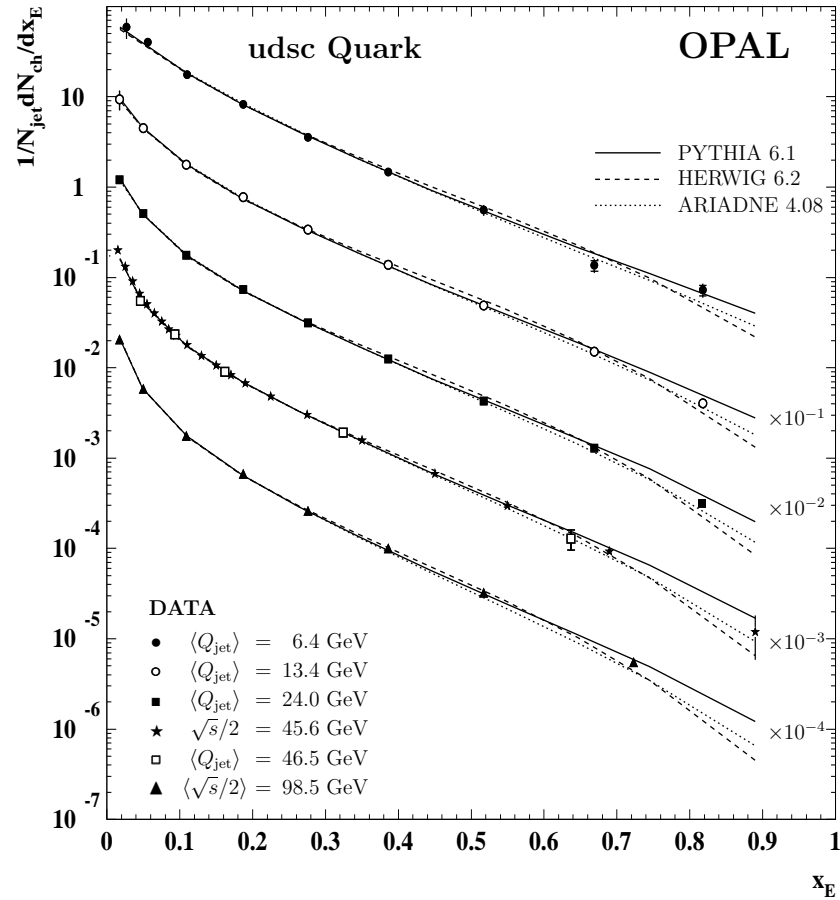

Hadron-Hadron Processes

- In hard hadron-hadron scattering, constituent partons from each incoming hadron interact at short distance (large momentum transfer Q^2).

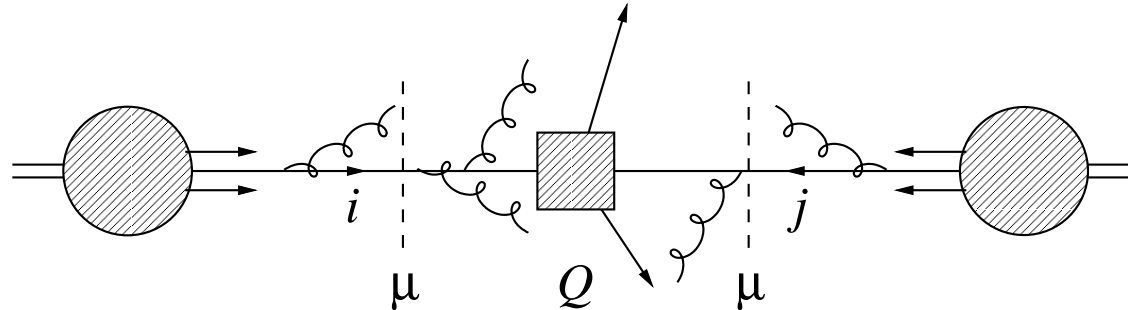

- For hadron momenta P_1, P_2 ($S = 2P_1 \cdot P_2$), form of cross section is

$$\sigma(S) = \sum_{i,j} \int dx_1 dx_2 D_i(x_1, \mu) D_j(x_2, \mu) \hat{\sigma}_{ij}(\hat{s} = x_1 x_2 S, \alpha_S(\mu), Q/\mu)$$

where μ is **factorization scale** and $\hat{\sigma}_{ij}$ is **subprocess** cross section for parton types i, j .

- ❖ Factorization scale is in principle arbitrary: it affects only what we call part of subprocess or part of initial-state evolution (parton shower).
- ❖ Rapidity of subprocess c.m. frame $p^\mu = p_1^\mu + p_2^\mu$:

$$y \equiv \frac{1}{2} \ln \left[\frac{(p^0 + p_3)}{(p^0 - p_3)} \right] = \frac{1}{2} \ln (x_1/x_2)$$

- ❖ Unlike e^+e^- or ep , we may have interaction between **spectator** partons, leading to *soft underlying event* and/or *multiple hard scattering*.

Parton-Parton Luminosities

- Useful to define the differential parton-parton luminosity $dL_{ij}/d\hat{s} dy$ and its integral $dL_{ij}/d\hat{s}$:

$$\frac{dL_{ij}}{d\hat{s} dy} = \frac{1}{S} \frac{1}{1 + \delta_{ij}} [D_i(x_1, \mu) D_j(x_2, \mu) + (1 \leftrightarrow 2)] .$$

Factor with Kronecker delta avoids double-counting when partons are identical.

- We have $d\hat{s} dy = S dx_1 dx_2$ and hence

$$\begin{aligned} \sigma &= \sum_{i,j} \int d\hat{s} dy \left(\frac{dL_{ij}}{d\hat{s} dy} \right) \hat{\sigma}_{ij}(\hat{s}) \\ &= \sum_{i,j} \int d\hat{s} \left(\frac{dL_{ij}}{d\hat{s}} \right) \hat{\sigma}_{ij}(\hat{s}) \end{aligned}$$

- This can be used to estimate the production rate for subprocesses at LHC.

- Figure shows parton-parton luminosities at $\sqrt{s} = 14$ TeV for various parton combinations, calculated using the CTEQ6.1 parton distribution functions and scale $\mu = \sqrt{\hat{s}}$. Widths of curves estimate PDF uncertainties.

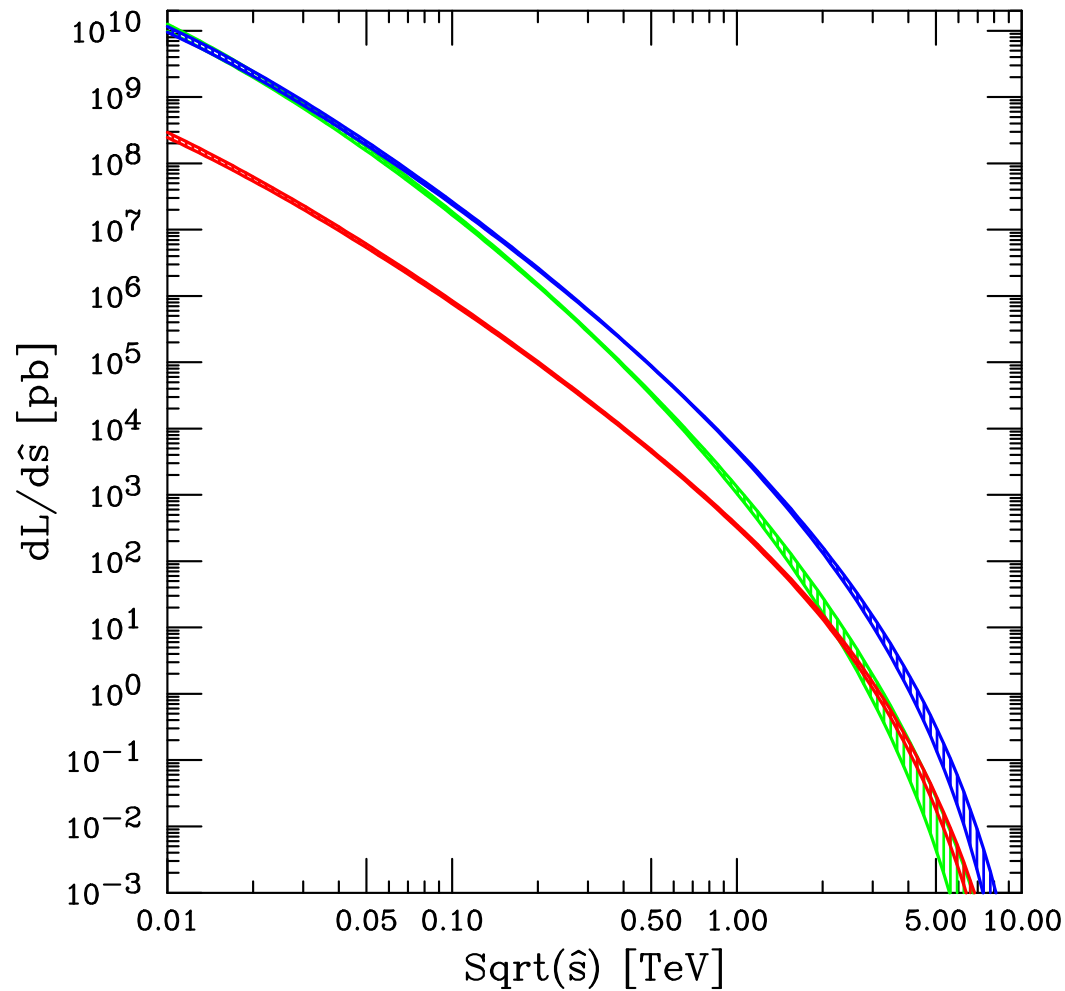

Green = gg , Blue = $gq + g\bar{q} + qq + \bar{q}g$, Red = $q\bar{q} + \bar{q}q$ ($q = d + u + s + c + b$).

Lepton Pair Production

- Inverse of $e^+e^- \rightarrow q\bar{q}$ is **Drell-Yan** process. At $\mathcal{O}(\alpha_S^0)$, mass distribution of lepton pair is given by

$$\frac{d\hat{\sigma}}{dM^2}(q\bar{q} \rightarrow \gamma^* \rightarrow l^+l^-) = \frac{4\pi\alpha^2}{\hat{s}} \frac{1}{3} Q_q^2 \delta(M^2 - \hat{s})$$

- ❖ Factor of $1/3 = 1/N$ instead of $3 = N$ because of *average* over colours of incoming q .

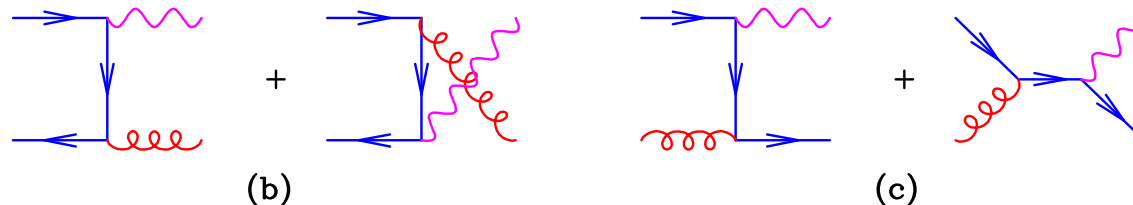
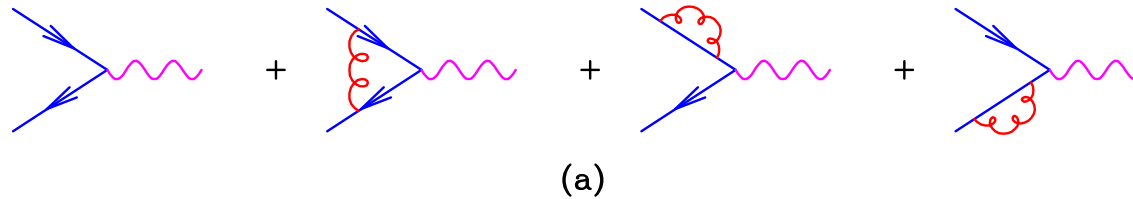

(c)

- ❖ In higher orders *vertex corrections* (a) have $M^2 = \hat{s}$,
gluon emission (b) and *QCD Compton* (c) diagrams give $M^2 < \hat{s}$.

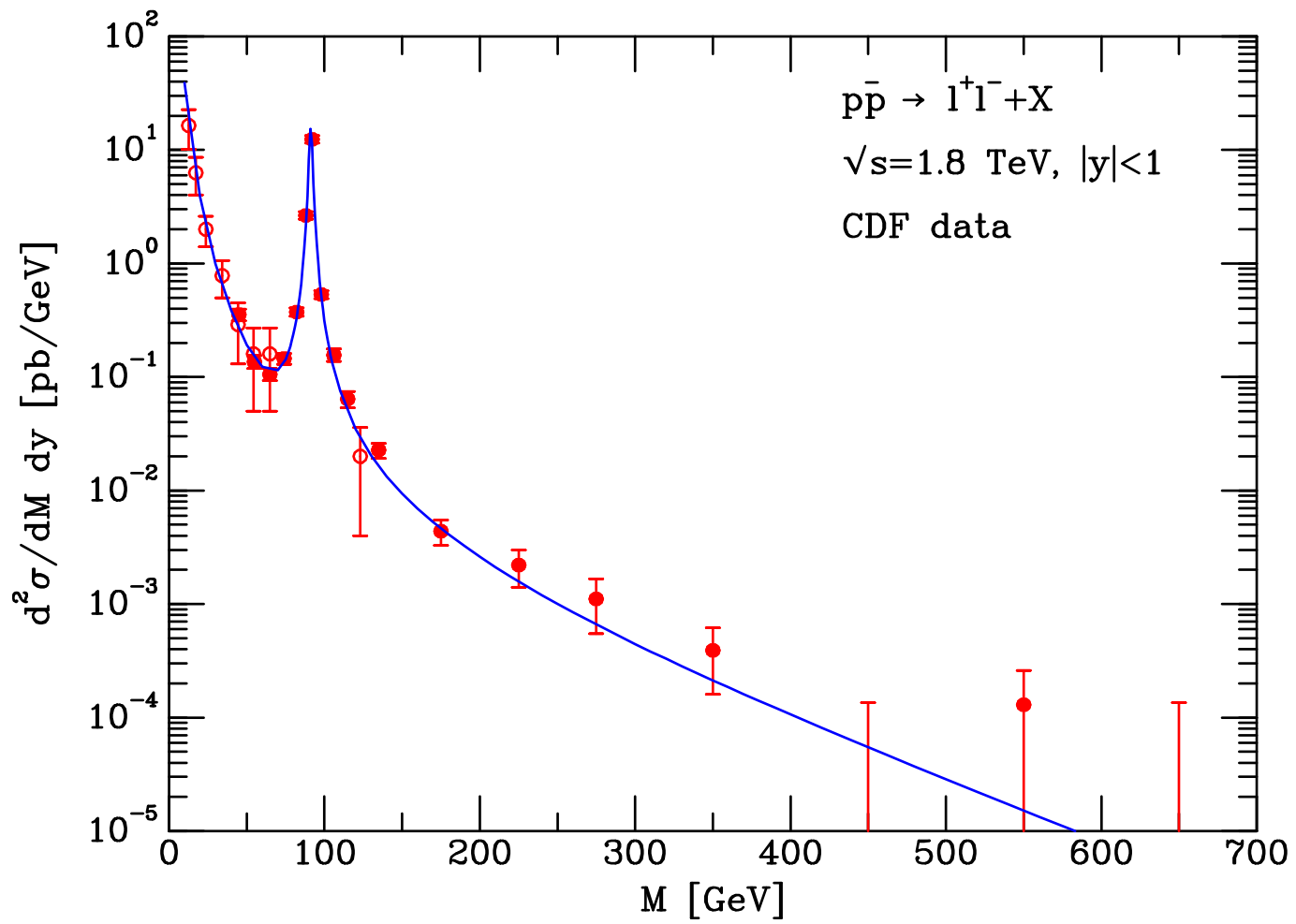

- W^\pm boson production is similar, except sensitive to different parton distributions, e.g.

$$u\bar{d} \rightarrow W^+ \rightarrow l^+\nu_l$$

- Transverse momentum of lepton pair, p_T measures net transverse momentum of colliding partons plus any *intrinsic* p_T :

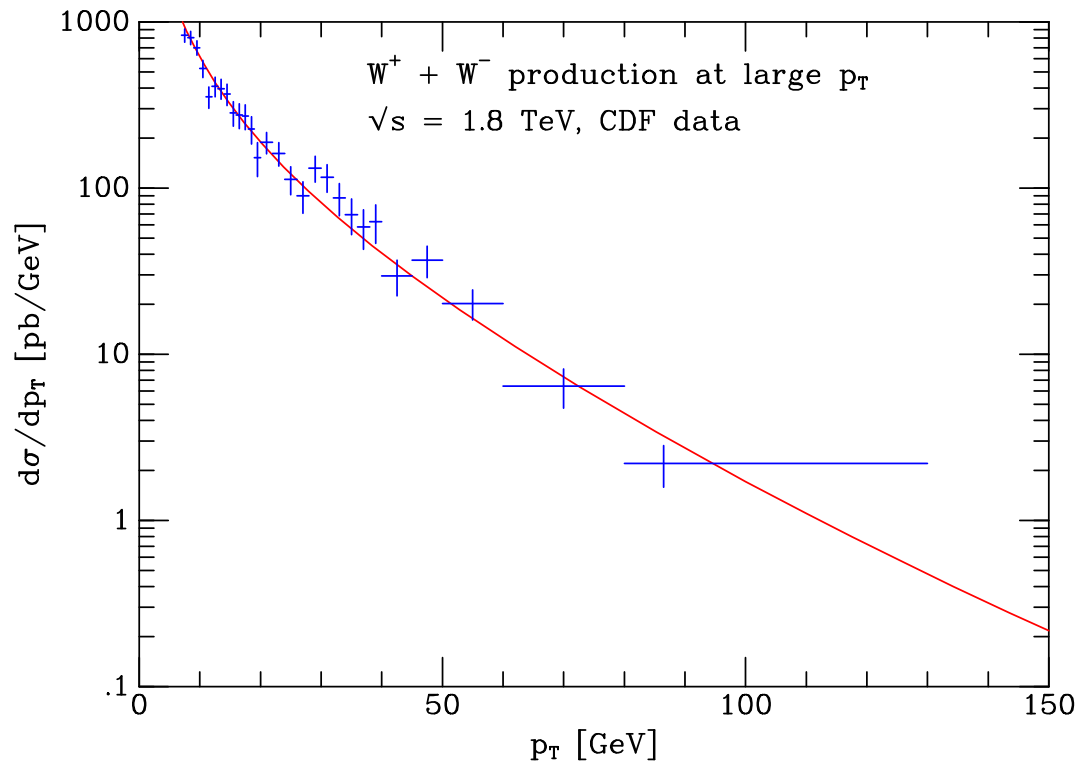

Jet Production

- Lowest-order subprocess for purely hadronic jet production is $2 \rightarrow 2$ scattering $p_1 + p_2 \rightarrow p_3 + p_4$

$$\begin{aligned} \frac{d\hat{\sigma}}{d\Phi_{34}} &\equiv \frac{E_3 E_4 d^6\hat{\sigma}}{d^3\mathbf{p}_3 d^3\mathbf{p}_4} \\ &= \frac{1}{32\pi^2 \hat{s}} \sum |\mathcal{M}|^2 \delta^4(p_1 + p_2 - p_3 - p_4) . \end{aligned}$$

- Many processes even at $\mathcal{O}(\alpha_S^2)$:

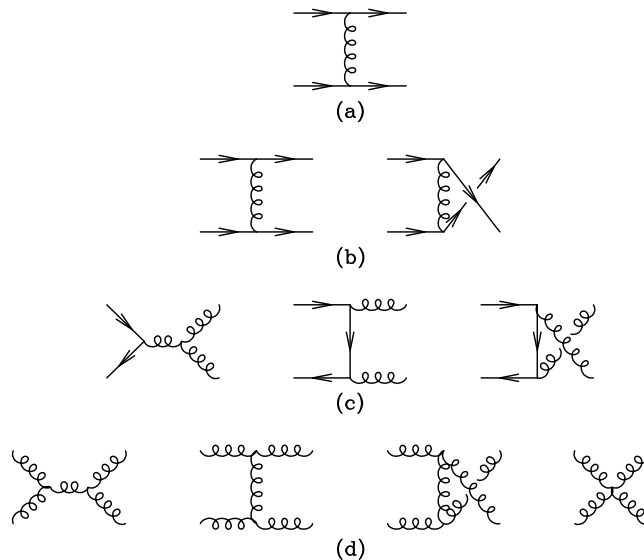

- **Single-jet inclusive** cross section obtained by integrating over one outgoing momentum:

$$\begin{aligned} \frac{E d^3 \hat{\sigma}}{d^3 \mathbf{p}} &= \frac{d^3 \hat{\sigma}}{d^2 \mathbf{p}_T dy} \longrightarrow \frac{1}{2\pi E_T} \frac{d^3 \hat{\sigma}}{dE_T d\eta} \\ &= \frac{1}{16\pi^2 \hat{s}} \overline{\sum} |\mathcal{M}|^2 \delta(\hat{s} + \hat{t} + \hat{u}) \end{aligned}$$

where (neglecting jet mass)

$$E_T \equiv E \sin \theta = |\mathbf{p}_T|, \quad \eta \equiv -\ln \tan(\theta/2) = y.$$

- Jets can be defined by a modified version of **k_T algorithm** discussed for e^+e^- in Lecture 2:
 - ❖ For each final-state momentum p_i and each pair of final-state momenta p_i, p_j , define

$$k_{Ti} = E_{Ti}, \quad k_{Tij} = \min\{E_{Ti}, E_{Tj}\} \Delta R_{ij} / D$$

where $\Delta R_{ij} = \sqrt{(\eta_i - \eta_j)^2 + (\phi_i - \phi_j)^2}$ and $D =$ dimensionless parameter for angular size of jets ($D = 0.5 - 1.0$)

- ❖ If k_{TI} is the smallest in the list of $\{k_{Ti}, k_{Tij}\}$, define I as a jet and remove from list.
 - ❖ If k_{TIJ} is the smallest, combine I, J into one object K with $p_K = p_I + p_J$.
 - ❖ Repeat until list is empty.
- Use η rather than θ for invariance under longitudinal boosts: $x_1 \rightarrow ax_1, x_2 \rightarrow x_2/a$ gives $\eta_i \rightarrow \eta_i + \ln a$, so $\eta_i - \eta_j$ is invariant.

- NLO predictions and data agree very well:

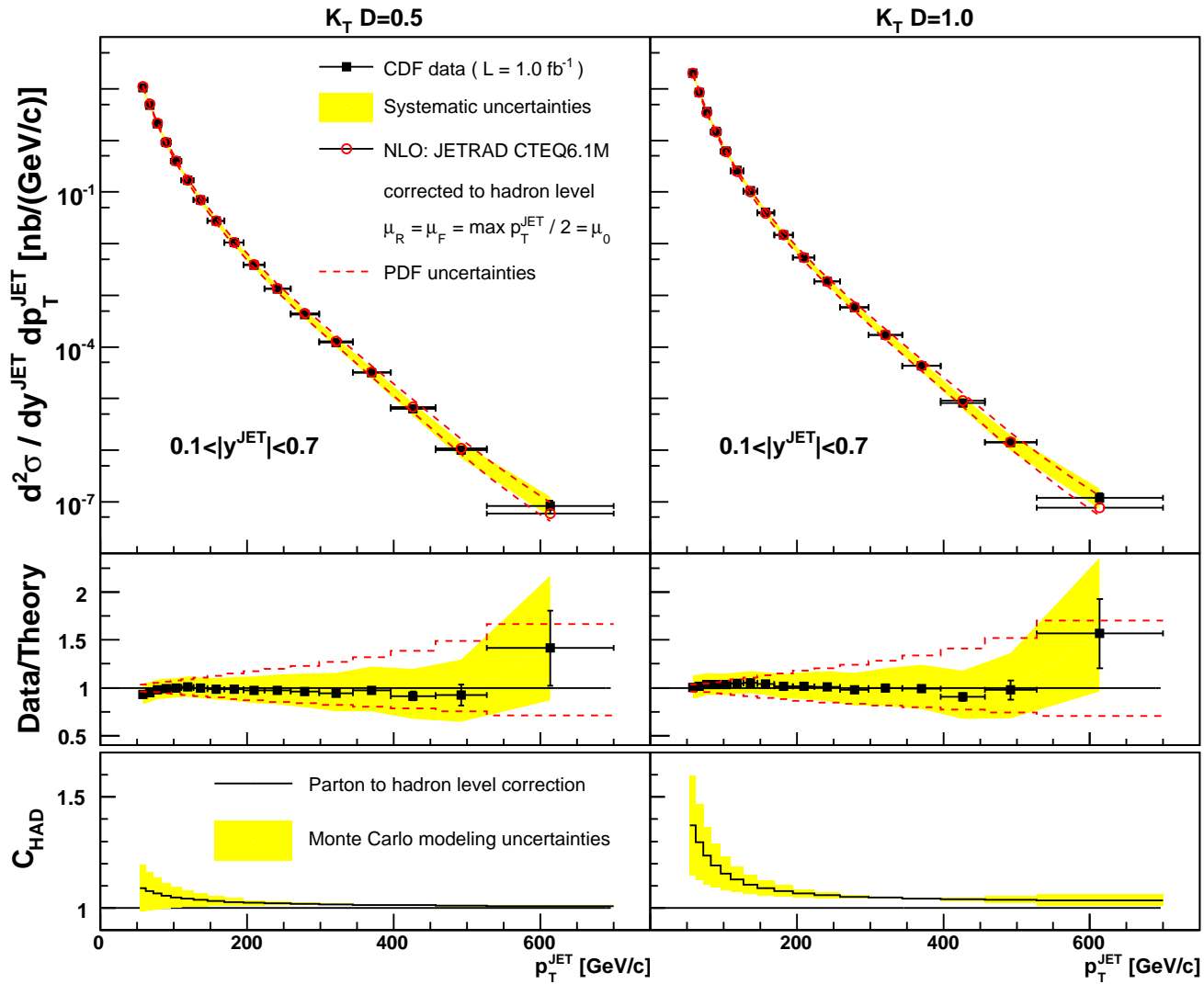

● Rapidity dependence:

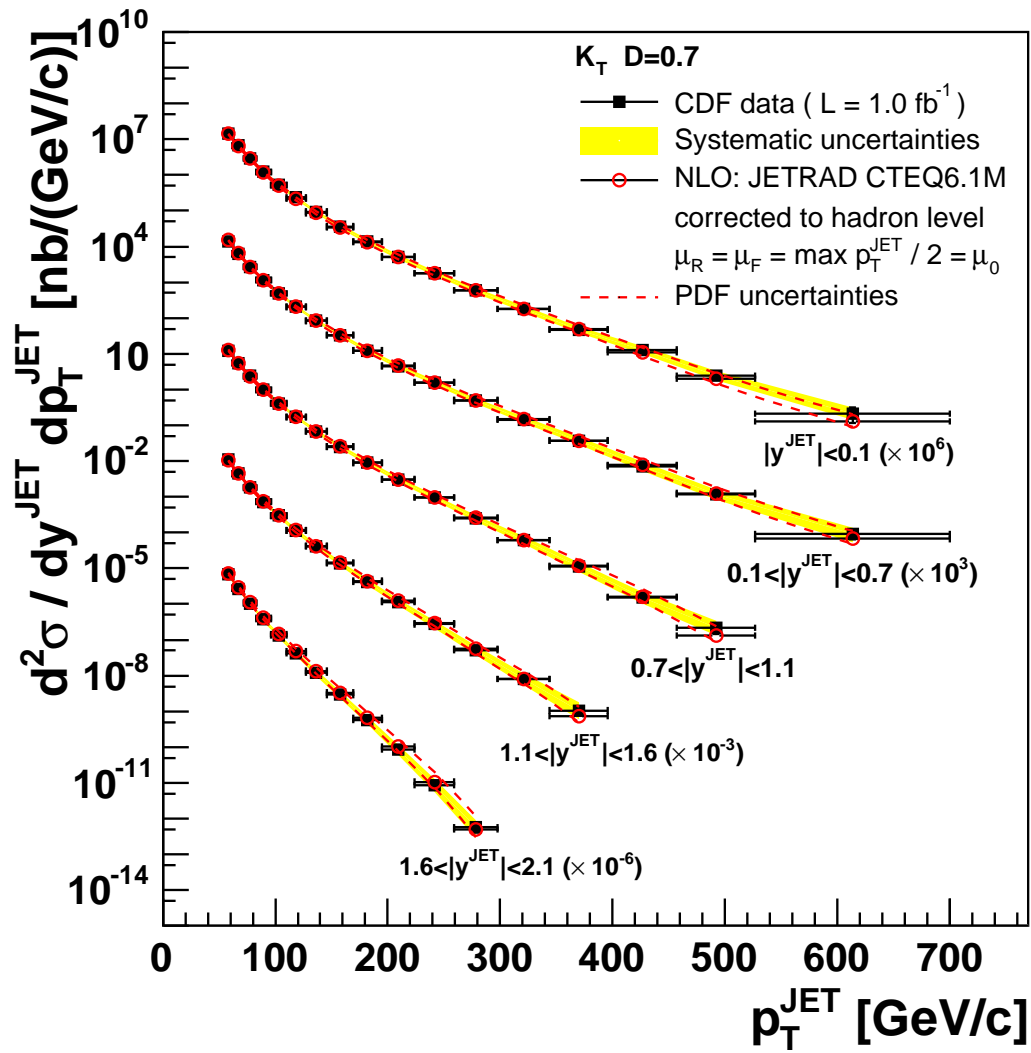

- Contribution of different parton combinations determined by subprocess cross sections and parton distributions.

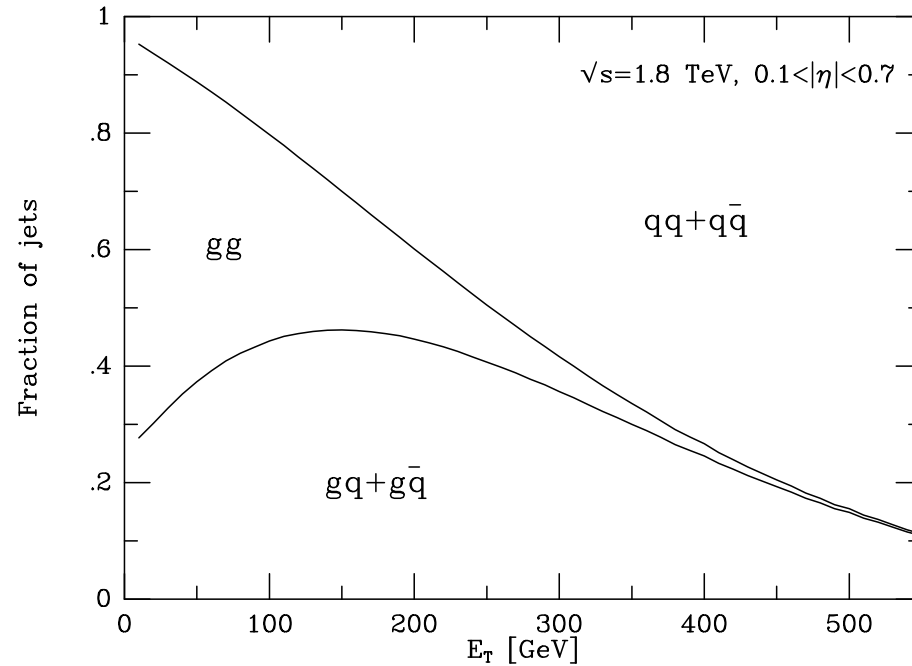

- Quarks dominate at large E_T since this selects large $x_{1,2}$:

$$\hat{s} = x_1 x_2 S > 4E_T^2$$

Heavy Quark Production

- Lowest-order subprocesses for heavy quark production are (a) light quark-antiquark annihilation (10% at LHC) and (b) gluon-gluon fusion (90% at LHC)

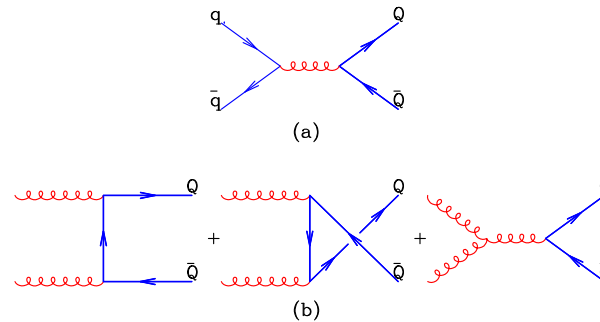

- NLO top quark cross section = $840 \pm 30(\text{scale}) \pm 20(\text{pdf})$ pb at LHC

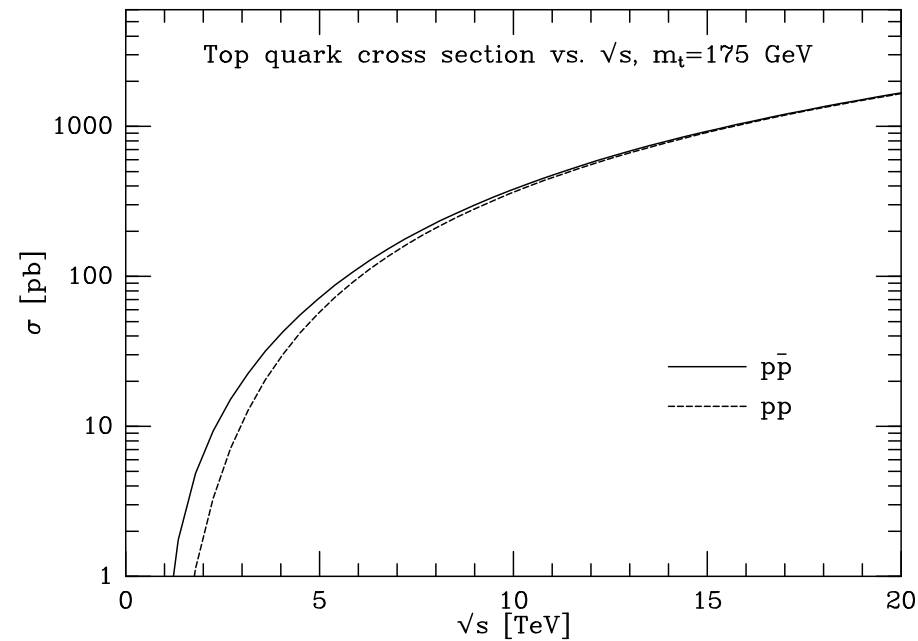

Standard Model Higgs Boson Production

- Lowest-order subprocesses for Higgs boson production at hadron colliders:
 - (a) Gluon-gluon fusion (via top loop)
 - (b) Vector boson fusion
 - (c) Associated production with W, Z boson
 - (d) Associated production with $t\bar{t}$.

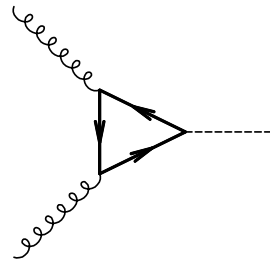

(a)

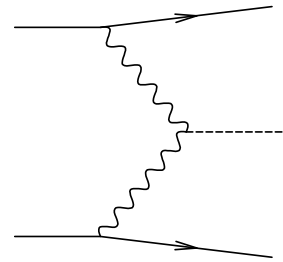

(b)

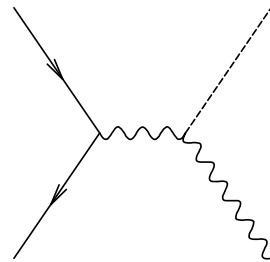

(c)

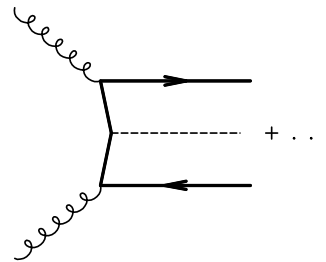

(d)

● NLO Higgs cross sections

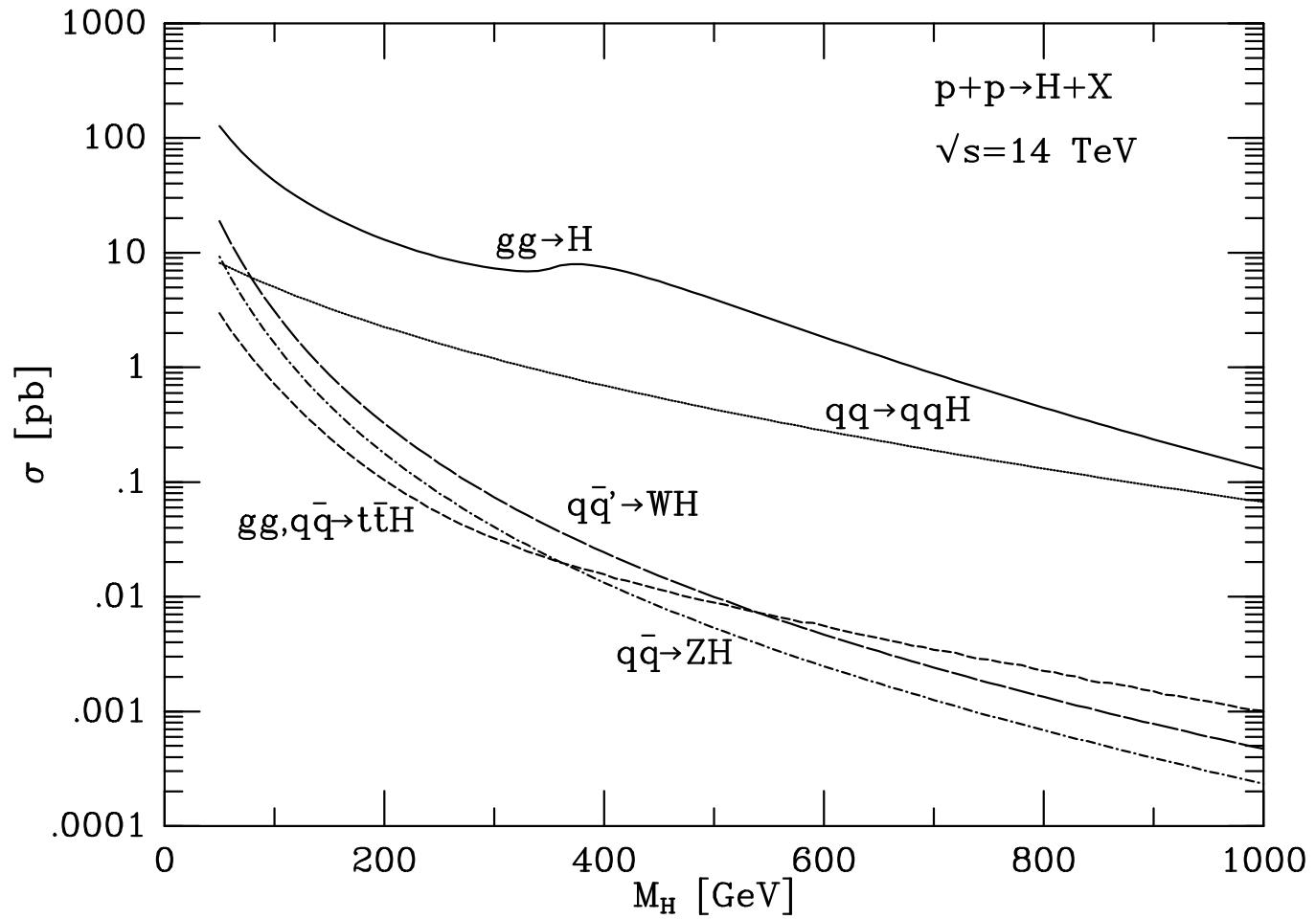

- Discovery decay channels depend on Higgs mass

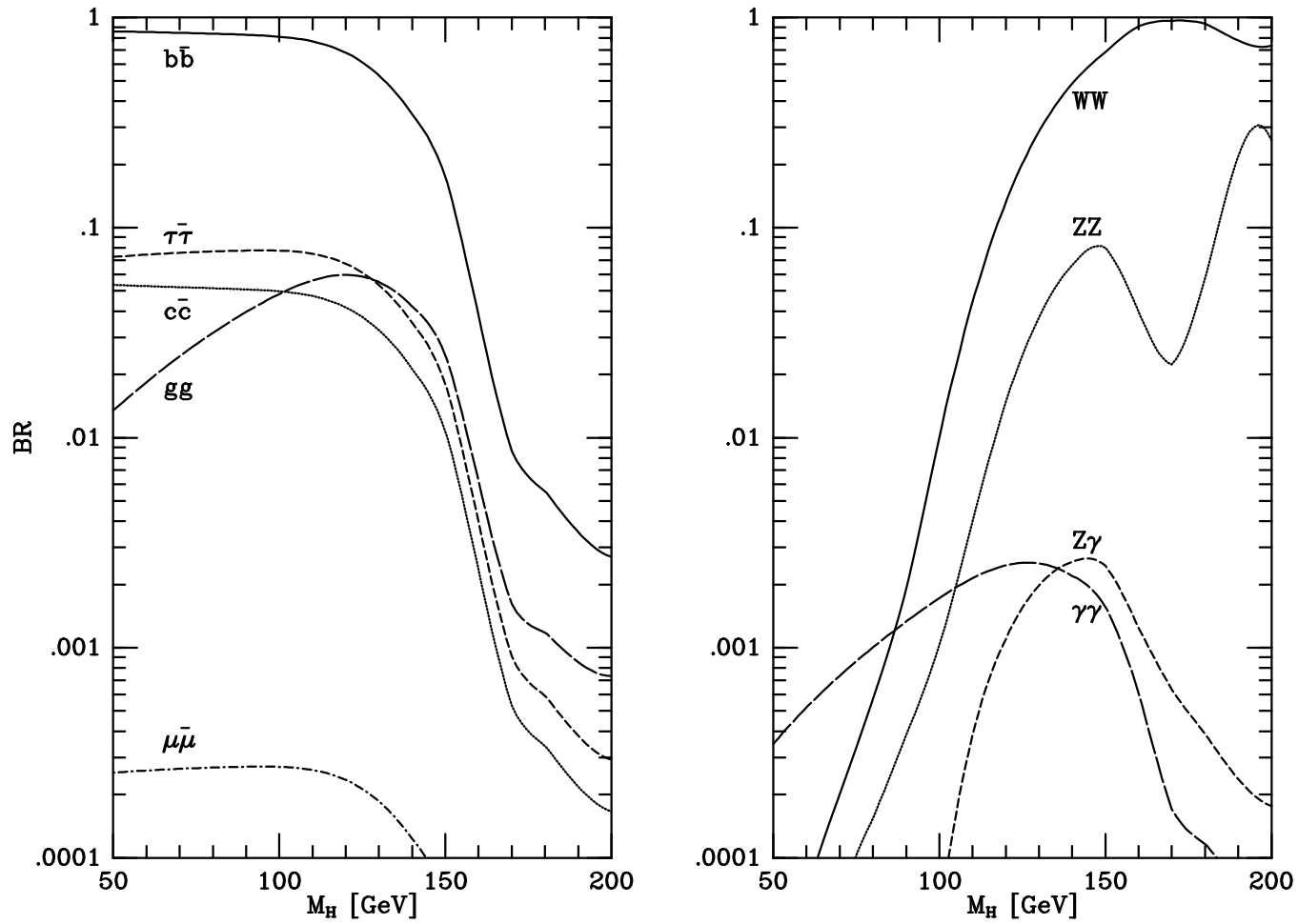

Status of NLO Calculations for LHC

- $2 \rightarrow 2$ parton processes — all available, e.g. in MCFM (CaEi*)
- $2 \rightarrow 3$ parton processes

Final State	Authors*	Comments
3 jets	KuSiTr,BerDixKo,GiKi,Na	Public code available
$V + 2$ jets	EiCa,CaGIMi	Public code available
$V b \bar{b}$	EiCa	Massless b quarks
$V b \bar{b}$	ReFeWa	Massive b quarks
$H + 2$ jets	FiOlZep	Vector boson fusion
$H + 2$ jets	CaEiZa	Gluon fusion
$VV + 2$ jets	JaOlZep	Vector boson fusion
$\gamma\gamma$ jet	deFKu,DelMalNaTr,BiGuMah	
$t\bar{t}H, b\bar{b}H$	ReDaWaOr,BeeDitKrPISpZer	
$t\bar{t}$ jet	DitUwWe	
HHH	PIRa,BiKarKauRu	
WW jet	DiKalUw	
ZZZ	LaMePe	

*Beenakker,Bern,Binoth,Campbell,Dawson,deFlorian,DelDuca,Dittmaier,Dixon,Ellis,FebresCordero,Figy,Giele,Glover,Guillet,Jager,Kallweit,Karg,Kauer,Kilgore,Kramer,Kosower,Kunszt,Lazopoulos,Mahmoudi,Maltoni,Melnikov,Miller,Nagy,Oleari,Orr,Petriello,Plehn,Plumper,Rauch,Reina,Ruckl,Signer,Spira,Troscsanyi,Uwer,Wackerroth,Weinzierl,Zanderighi,Zeppenfeld,Zerwas

- Les Houches 2005 wish list of “feasible” NLO calculations

Final State	Relevance	Progress?
$V V \text{ jet}$	$t\bar{t}H$, new physics	$VV = \gamma\gamma, WW$
$V V V$	SUSY trilepton	ZZZ
$V V b\bar{b}$	$VBF \rightarrow H \rightarrow VV, t\bar{t}H$, new physics	
$V V + 2 \text{ jets}$	$VBF \rightarrow H \rightarrow VV$	
$V + 3 \text{ jets}$	various new physics signatures	
$t\bar{t} + 2 \text{ jets}$	$t\bar{t}H$	
$t\bar{t} b\bar{b}$	$t\bar{t}H$	

- Les Houches 2007: $WWW, b\bar{b}b\bar{b}$, 4 jets added.

Summary of Lecture 4

- Jet fragmentation functions also obey DGLAP evolution equations.
 - ❖ Scaling violation seen in e^+e^- .
 - ❖ Small- x fragmentation sensitive to coherence effects.
 - ❖ Gaussian peak in $\ln(1/x)$, peak position shows coherence.
 - ❖ Average hadron multiplicity predicted.
- Hadronization models needed for simulation of full final states.
 - ❖ General ideas describe spectra and event shapes.
 - Local parton-hadron duality.
 - Universal low-scale α_S .
 - ❖ Specific models needed for hadron distributions.
 - String model (PYTHIA).
 - Cluster model (HERWIG).
- In hadron-hadron processes, factorization permits cross section calculations.
 - ❖ Parton-parton luminosities important: uncertainties $\sim 10 - 20\%$.
 - ❖ Lepton-pair, jet, top and Higgs production reliably predicted (NLO or NNLO).
 - ❖ All $2 \rightarrow 2$ and many $2 \rightarrow 3$ subprocesses predicted to NLO.