



Search for Heavy Neutral Leptons at SPS

on behalf of

W. Bonivento^{1,2}, A. Boyarsky³, H. Dijkstra², U. Egede⁴, M. Ferro-Luzzi², B. Goddard²,
A. Golutvin⁴, D. Gorbunov⁵, R. Jacobsson², J. Panman², M. Patel⁴, O. Ruchayskiy⁶,
T. Ruf², N. Serra⁷, M. Shaposhnikov⁶, D. Treille² (‡)

¹Sezione INFN di Cagliari, Cagliari, Italy

²European Organization for Nuclear Research (CERN), Geneva, Switzerland

³Instituut-Lorentz for Theoretical Physics, Universiteit Leiden, Niels Bohrweg 2, Leiden, The Netherlands

⁴Imperial College London, London, United Kingdom

⁵Institute for Nuclear Research of the Russian Academy of Sciences (INR RAN), Moscow, Russia

⁶Ecole Polytechnique Fédérale de Lausanne (EPFL), Lausanne, Switzerland

⁷Physik-Institut, Universität Zürich, Zürich, Switzerland

(‡)retired

Expression of Interest presented at 111th Meeting of SPSC, October 22, 2013 :

CERN-SPSC-2013-024 / SPSC-EOI-010 / arXiv:1310.1762v1 [hep-ex] 7 Oct 2013



Physics Situation after LHC Run 1

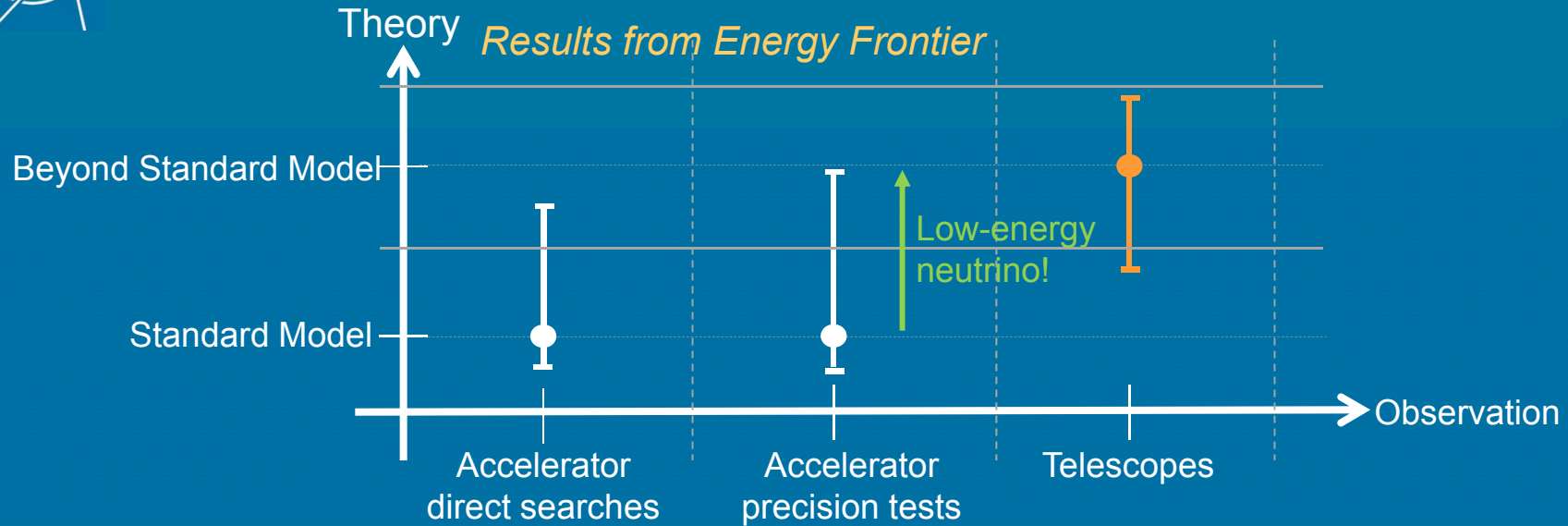

Standard Model success: Higgs!

- $m_H < 175 \text{ GeV}$: Landau pole in the self-interaction is above the quantum gravity scale $M_{\text{Pl}} \sim 10^{19} \text{ GeV}$
- $m_H > 111 \text{ GeV}$: Electroweak vacuum is sufficiently stable with a lifetime $\gg t_U$

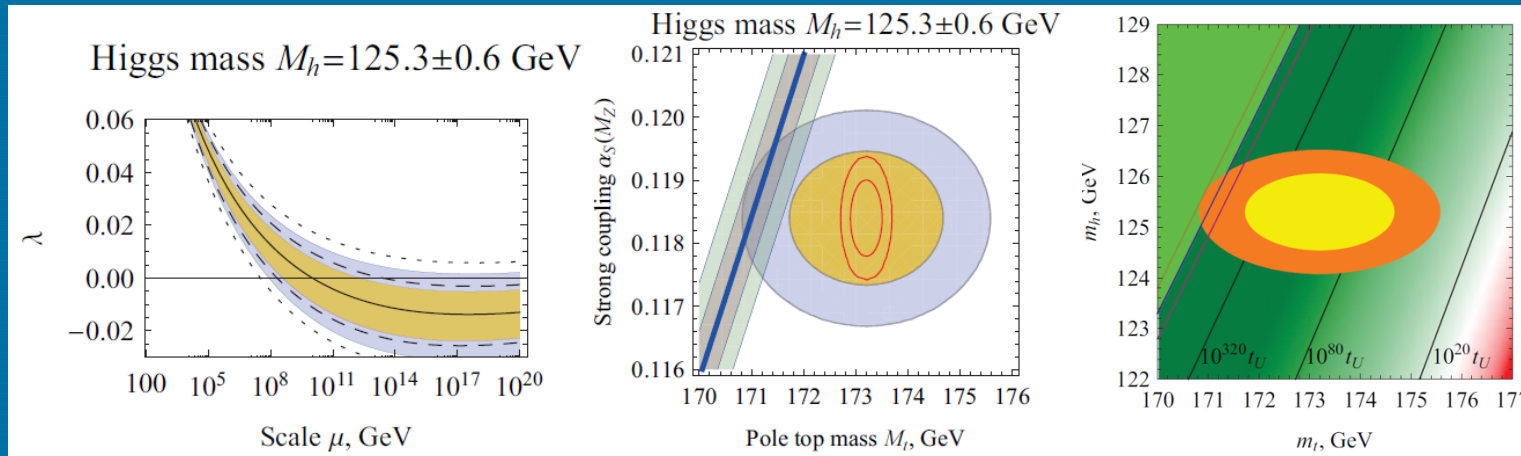

arXiv:0906.0954



Physics Situation after LHC Run 1

- With a mass of the Higgs boson of 125 – 126 GeV the Standard Model is a self-consistent weakly coupled effective field theory up to very high scales (probably up to the Planck scale) without adding new particles

→ No need for new particles up to Planck scale!?

Outstanding questions

1. **Neutrino oscillations**: tiny masses and flavour mixing

→ Requires new degrees of freedom in comparison to SM

2. **Baryon asymmetry of the Universe**

→ Measurements from BBN and CMB $\eta = \left\langle \frac{n_B}{n_\gamma} \right\rangle_{T=3K} \sim \left\langle \frac{n_B - n_{\bar{B}}}{n_B + n_{\bar{B}}} \right\rangle_{T \gtrsim 1 \text{ GeV}} \sim 6 \times 10^{-10}$

→ Current measured CP violation in quark sector → $\eta \sim 10^{-20}$!!

3. **Dark Matter** from indirect gravitational observations

→ Non-baryonic, neutral and stable or long-lived

4. **Dark Energy**

5. **Gauge hierarchy** and stability of Higgs mass

6. **SM flavour structure**

→ While we had unitarity bounds for the Higgs, no such indication on the next scale....

- Search for beyond Standard Model physics at the **Energy Frontier**:

- Higgs and top (EW) precision physics
- Flavour precision physics
- Continued direct searches for new particles

Alternative Path

- What about new particles *below* Fermi scale and weak couplings?



A Natural Standard Model Extension !



Ockham's Razor

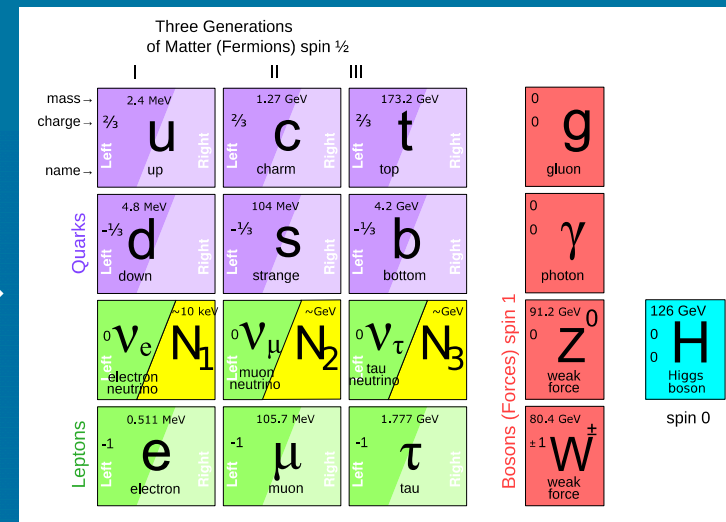
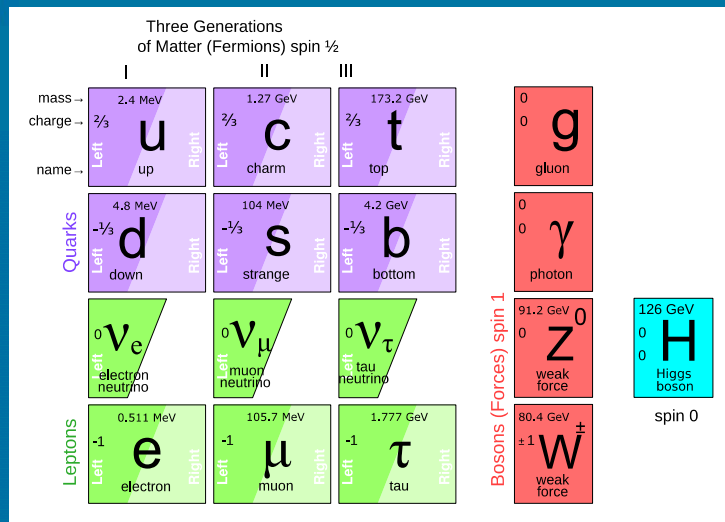

- Introduce three neutral fermion singlets – right-handed Majorana leptons N_I with Majorana mass $m_I^R \equiv$ "Heavy Neutral Leptons (HNL)"
 - Make the leptonic sector similar to the quark sector
 - No electric, strong or weak charges → sterile

Minkowski 1977
 Yanagida 1979
 Gell-Mann, Ramond, Slansky 1979
 Glashow 1979

$$\mathcal{L} = \mathcal{L}_{SM} + \sum_{I=1,2,3} \sum_{\ell=1,2,3(e,\mu,\tau)} i\bar{N}_I \partial_\mu \gamma^\mu N_I - Y_{I\ell} \bar{N}_I \Phi^\dagger L_\ell - m_I^R \bar{N}_I^c N_I + h.c$$

where L_ℓ are the lepton doublets, Φ is the Higgs doublet, and $Y_{I\ell}$ are the corresponding new Yukawa couplings

- Discovery of Higgs vital for the see-saw model! → Responsible for the Yukawa couplings!



Type I See-saw

- $Y_{I\ell} \bar{N}_I \Phi^\dagger L_\ell$ lepton flavour violating term results in mixing between N_I and SM active neutrinos when the Higgs SSB develops the $\langle VEV \rangle = v \sim 246 \text{ GeV}$
 - Oscillations in the mass-basis and matter-anti-matter asymmetry

- Mixing between N_I and active neutrino $U_{I\ell} = \frac{Y_{I\ell} v}{m_I^R} \sim \frac{m_D}{m^R}$
 - Total strength of coupling $U^2 = \sum_{\ell=1,2,3(e,\mu,\tau)} \sum_{I=1,2,3} \frac{v^2 |Y_{\ell I}|^2}{m_I^{R^2}}$

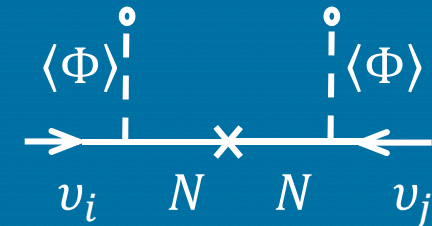

- Type I See-saw with $m^R \gg m_D (= Y_{I\ell} v)$ → superposition of chiral states give
 - Active neutrino mass in mass basis $\tilde{m}_1 \sim \frac{m_D^2}{m^R} \sim m_\nu$
 - Heavy singlet fermion mass in mass basis $\tilde{m}_2 \sim m^R \left(1 + \frac{m_D^2}{m^{R^2}}\right) \sim m^R \sim M_N$

arXiv:1204.5379

- Assumption that N_I are $\mathcal{O}(m_q/m_{l^\pm})$ (νMSM)
 - Yukawa couplings are very small
 - $Y_{I\ell} = \mathcal{O}\left(\frac{\sqrt{m_{atm} m_I^R}}{v}\right) \sim 10^{-8}$ ($m^R = 1 \text{ GeV}, m_\nu = 0.05 \text{ eV}$)
 - $U^2 \sim 10^{-11}$

→ Experimental challenge → Intensity Frontier

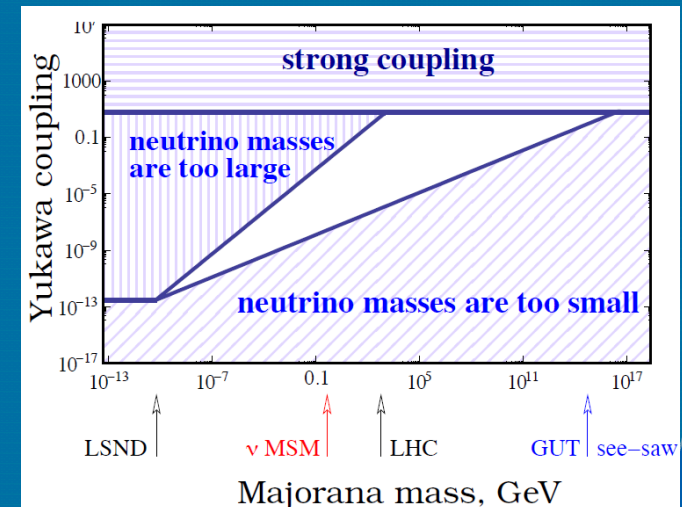

Role of N_1 with a mass of $\mathcal{O}(\text{keV})$
 → Dark Matter

Role of N_2 and N_3 with a mass of $\mathcal{O}(m_q/m_{l^\pm})$ (100 MeV – GeV):
 → Neutrino oscillations and mass, and BAU

- Assume lightest singlet fermion N_1 has a very weak mixing with the other leptons
 - Mass $M_1 \sim \mathcal{O}(10)\text{keV}$ and very small coupling
 - Sufficiently stable to act as Dark Matter candidate
 - Give the right abundance
 - Decouples from the primordial plasma very early
 - Decaying Dark Matter

Production from $\nu \leftrightarrow N$ oscillations

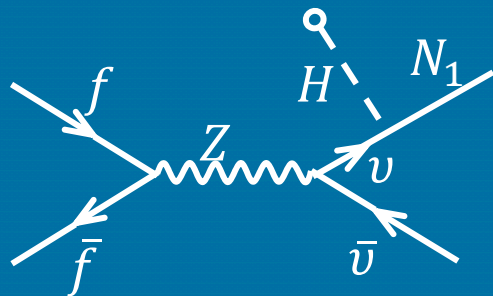

Dominant decay

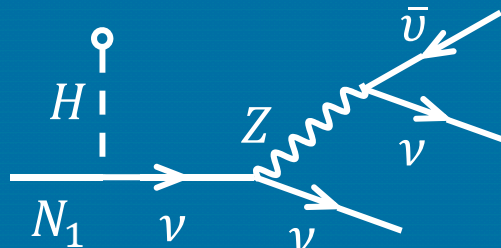

Subdominant radiative decay

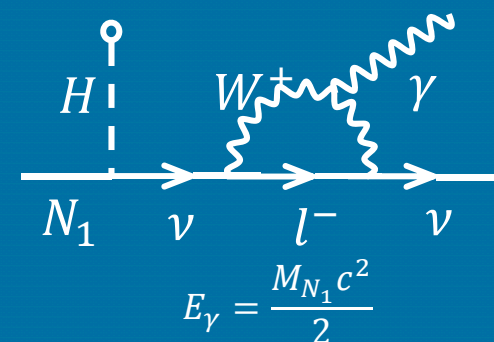



N_2 and N_3

○ N_1 as DM ($M_{N_1} \ll M_{N_2} \approx M_{N_3}$) gives no contribution to active neutrino masses

→ Neglect for the rest

→ Reduces number of effective parameters for Lagrangian with $N_{2,3}$

• 18 parameters → 11 new parameters:

- 2 Majorana masses
- 2 diagonal Yukawa couplings as Dirac masses
- 4 mixing angles
- 3 CP violating phases (only one in SM in quark sector)

→ Two mixing angles related to active neutrinos and mass difference measured in low-energy neutrino experiment

○ **Generation of BAU with N_2 and N_3** (Akhmedov, Rubakov, Smirnov; Asaka, Shaposhnikov)

1. **Leptogenesis from coherent resonant oscillations with interference between CP violating amplitudes**

→ Two fermion singlets should be quasi-degenerate

2. **Sterile neutrinos out of equilibrium ($\Gamma_{N_{2,3}} <$ Hubble rate of expansion) at the E.W. scale above the sphaleron freeze-out**

3. **Lepton number of active left-handed neutrinos transferred to baryon number by sphaleron processes**

• $\mathbb{L}_\ell - \frac{\mathbb{B}}{3}$ remain conserved while \mathbb{L}_ℓ and \mathbb{B} are violated individually

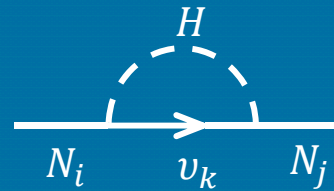
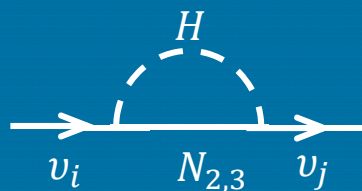
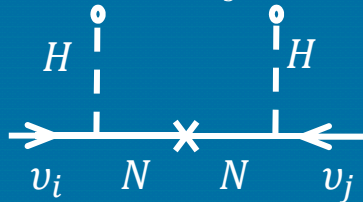

N_2 and N_3 Constraints

1. **See-saw**: Lower limit on mixing angle with active neutrinos to produce oscillations and masses
2. **BAU**: Upper limit on mixing angle to guarantee out-of-equilibrium oscillations ($\Gamma_{N_{2,3}} < H$)
3. **BBN**: Decays of N_2 and N_3 must respect current abundances of light nuclei
 → Limit on lifetime $\tau_{N_{2,3}} < 0.1s$ ($T > 3 MeV$)
4. **Experimental: No observation so far**
 → Constraints 1-3 now indicate that previous searches were largely outside interesting parameter space
 - PS191, BEBC, CHARM, CCFR, NuTeV

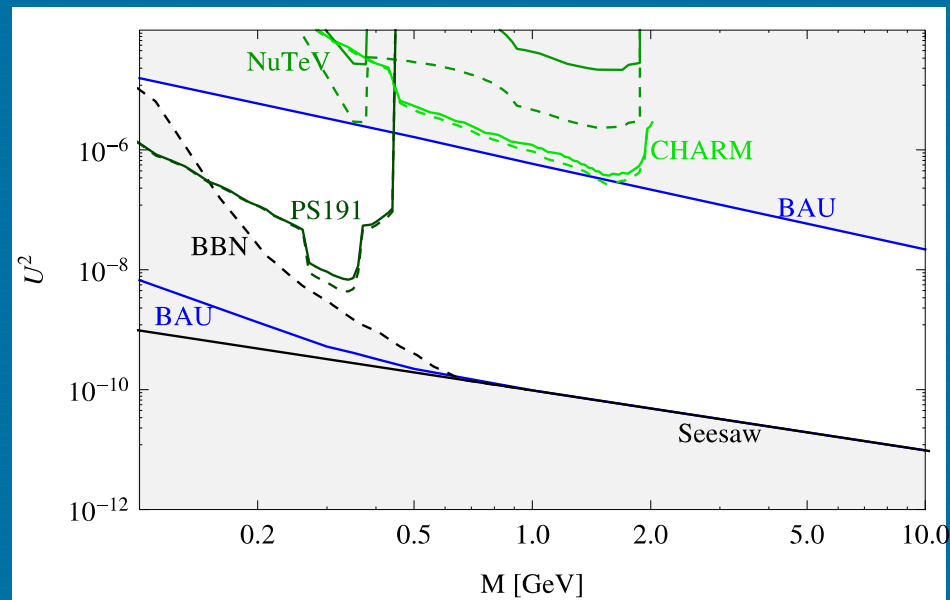

- Large fraction of interesting parameter space can be explored in accelerator based search
 - $m_\pi < M_N < 2 GeV$
 - $M_N > 2 GeV$ is not reachable at any operating facility

$N_{2,3}$ Production

Production in mixing with active neutrino from leptonic/semi-leptonic weak decays of charm mesons

- Total production depend on $\mathcal{U}^2 = \sum_{\ell=e,\mu,\tau} \sum_{I=1,2} |\mathcal{U}_{\ell I}|^2$
- Relation between $\mathcal{U}_e^2, \mathcal{U}_\mu^2$ and \mathcal{U}_τ^2 depends on exact flavour mixing
- Ratio of Yukawa couplings can be expressed through the elements of the active neutrino mixing matrix (arXiv:0605047)

Benchmark model II: muon flavour dominance

→ For the sake of determining a search strategy, assume scenario with a predominant coupling to the muon flavour

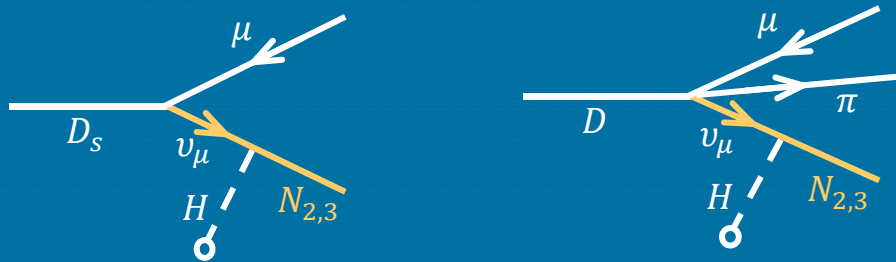

Production mechanism probes $\mathcal{U}_\mu^2 = \sum_{I=2,3} \frac{v^2 |Y_{\mu I}|^2}{m_I^2}$

→ $\text{Br}(D \rightarrow NX) \sim 10^{-8} - 10^{-12}$

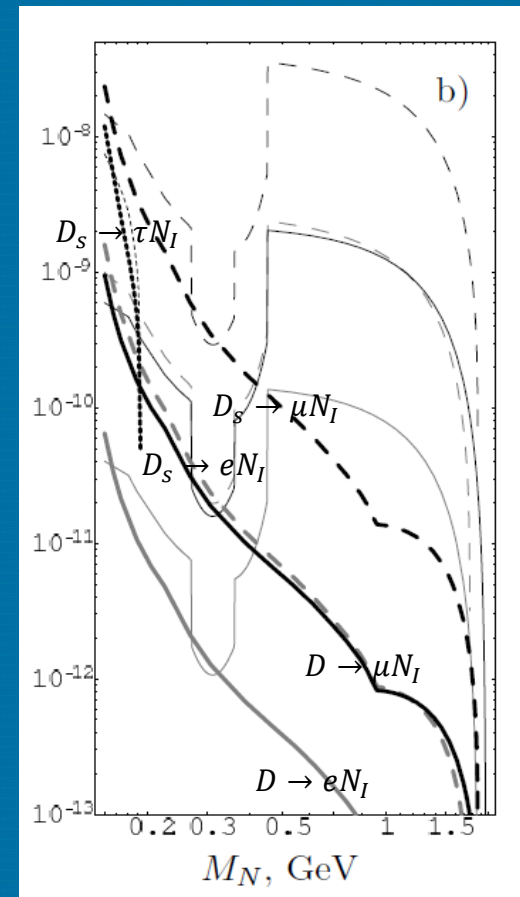

arXiv:0705.1729

$N_{2,3}$ Decay

- Very weak sterile-active neutrino mixing $\rightarrow N_{2,3}$ much longer lived than SM particles
 \rightarrow Typical lifetimes > 10 ms for $M_{N_{2,3}} \sim 1$ GeV \rightarrow Decay distance $\mathcal{O}(km)$
- Decay modes:
 - $N \rightarrow \mu e \nu, \pi^0 \nu, \pi e, \mu \mu \nu, \pi \mu, K e, K \mu, \eta \nu, \eta' \nu, \rho \nu, \rho e, \rho \mu, \dots$
 - Branching ratios depend on flavour mixing (again)
 - Typical:

| Decay mode | Branching ratio |
|--|-----------------|
| $N_{2,3} \rightarrow \mu/e + \pi$ | 0.1 - 50 % |
| $N_{2,3} \rightarrow \mu^-/e^- + \rho^+$ | 0.5 - 20 % |
| $N_{2,3} \rightarrow \nu + \mu + e$ | 1 - 10 % |

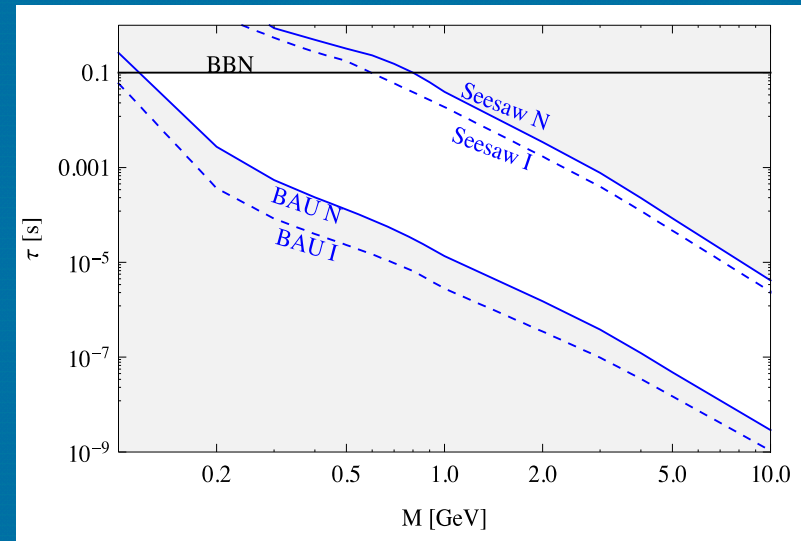

E.g.

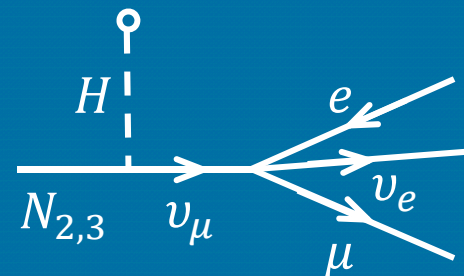
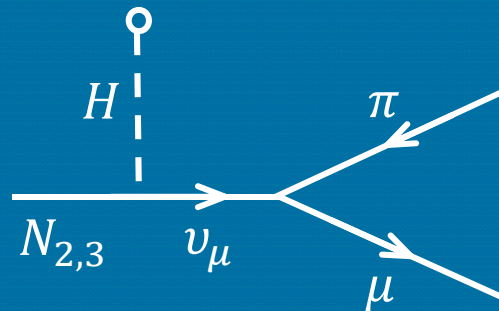

Experimental Requirements

Proposal: beam dump experiment at the SPS

1. Sensitivity $\propto \mathcal{U}^4 \rightarrow$ **Number of protons on target (p.o.t.)**
 - \rightarrow SPS: $4\text{-}5 \times 10^{13} / 6\text{-}7\text{s} = 500 \text{ kW} \rightarrow 2 \times 10^{20}$ in 4-5 years (similar to CNGS)
 - \rightarrow 400 GeV beam energy ($\sqrt{s} = 27.5 \text{ GeV}$) compromise between σ_{charm} and background conditions
2. Preference for relatively **slow beam extraction** $\mathcal{O}(ms - 1s)$ to reduce detector occupancy
3. **Heavy material target** to stop π, K before decay to reduce flux of active neutrinos
 - \rightarrow Blow up beam to dilute beam energy on target
4. Long **muon shield** to reduce flux of muons
5. Away from tunnel walls to reduce neutrino interactions in proximity of detector
6. **Vacuum in detector volume** to reduce neutrino interactions in detector
7. **Detector acceptance compromise between lifetime and $N_{2,3}$ production angle**
 - ...and length of shield to filter out muon flux

\rightarrow Incompatible with conventional neutrino facility

Gorbunov, Shaposhnikov

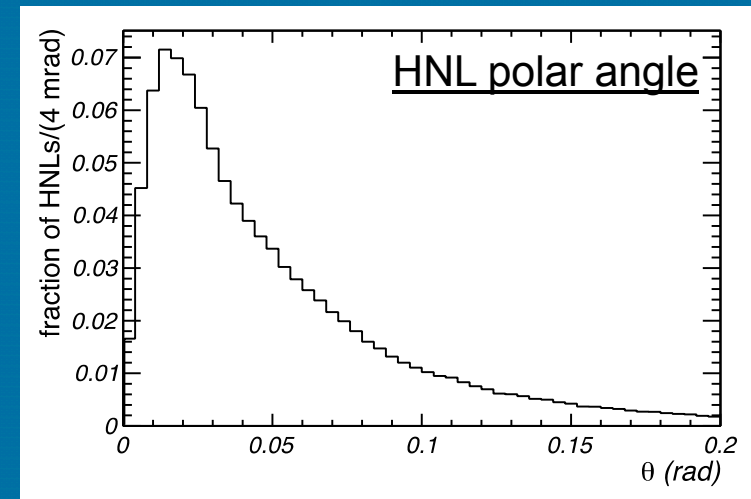
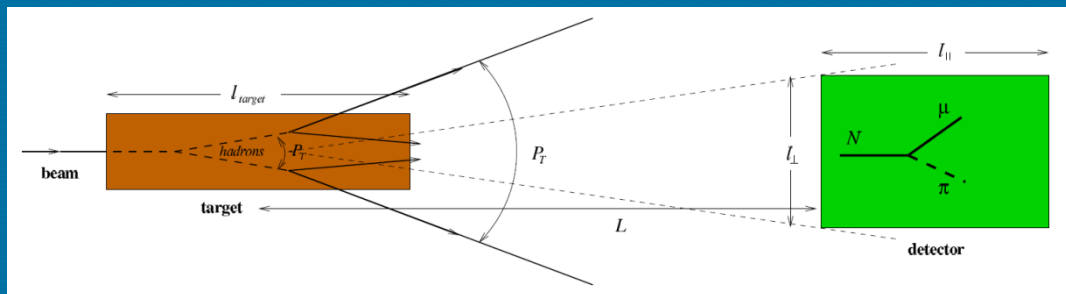



Schematic Principle of Experimental Setup

Initial reduction of beam induced background:

- Heavy target
- Hadron absorber
- Muon deflection / shield

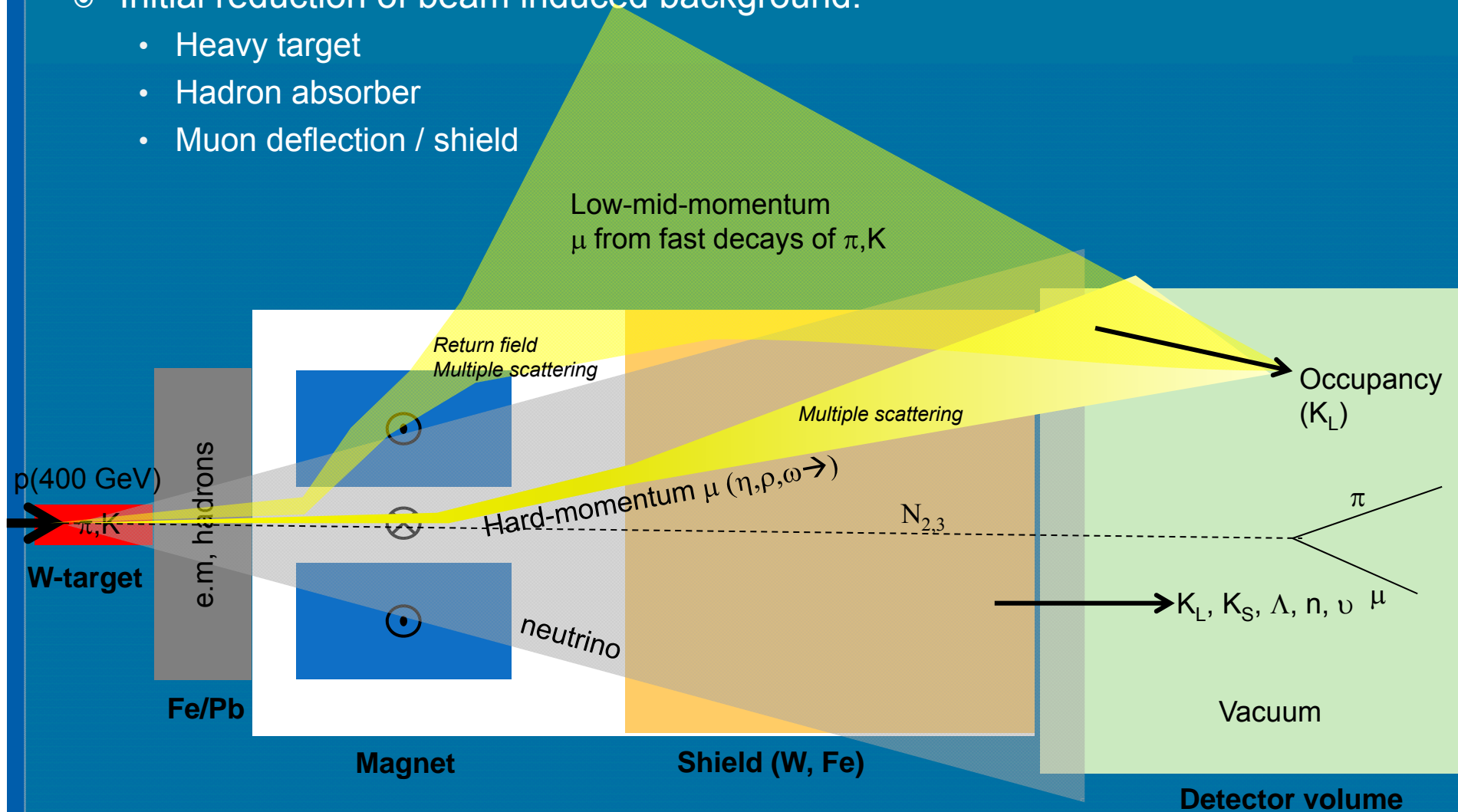

Generic setup, not to scale!

Muon Shield Optimization

- No shield: Rate at detector 5×10^9 muons / 5×10^{13} p.o.t.
 - Acceptable occupancy (<1%) per spill of 5×10^{13} p.o.t
 - Spill duration ~1s: $< 50 \times 10^6$ muons
 - Spill duration ~1ms: $< 50 \times 10^3$ muons
 - Spill duration ~10 μ s : < 500 muons
- Simulations with passive and active/passive shield
 - Stopping power of tungsten: 54m @ $E_\mu = 400$ GeV

Main sources of the muon flux (Pythia)

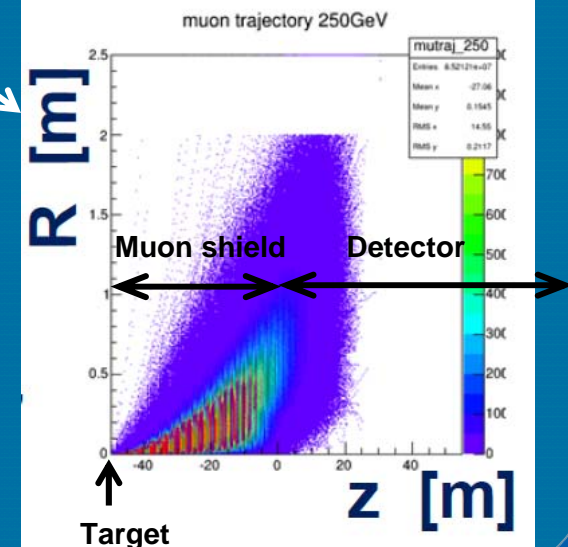
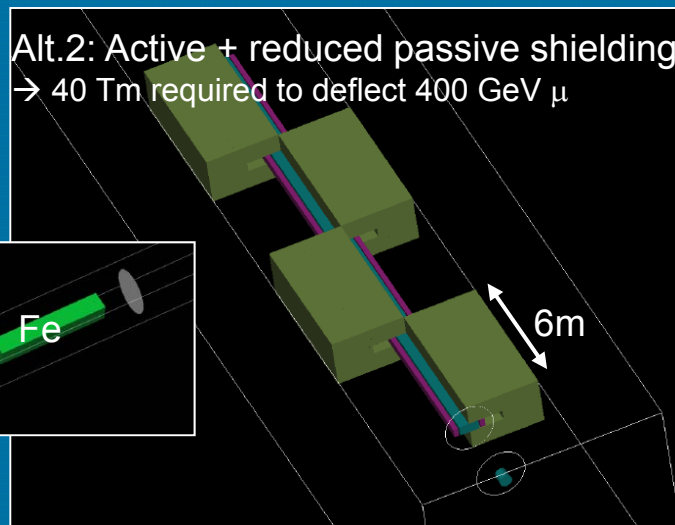
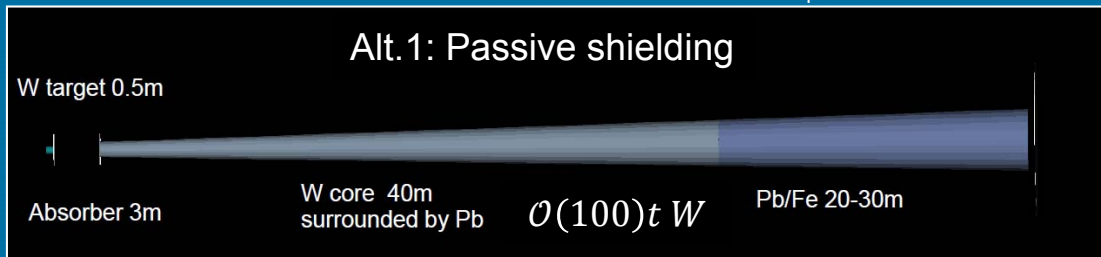
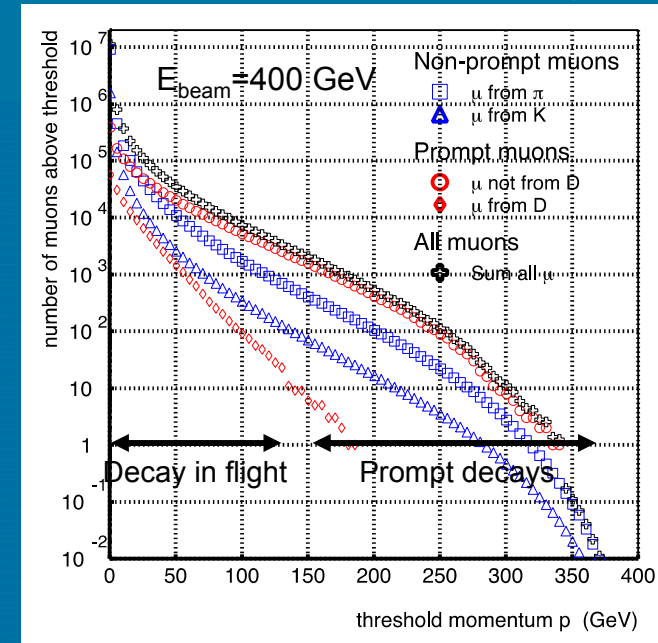

Detector Concept

Reconstruction of the HNL decays in the final states: $\mu\pi, \mu\rho, e\rho$

→ Requires long decay volume, magnetic spectrometer, muon detector and electromagnetic calorimeter, preferably in surface building

- Long vacuum vessel, 5 m diameter, 50 m length
- 10 m long magnetic spectrometer with 0.5 Tm dipole magnet and 4 low material tracking chambers

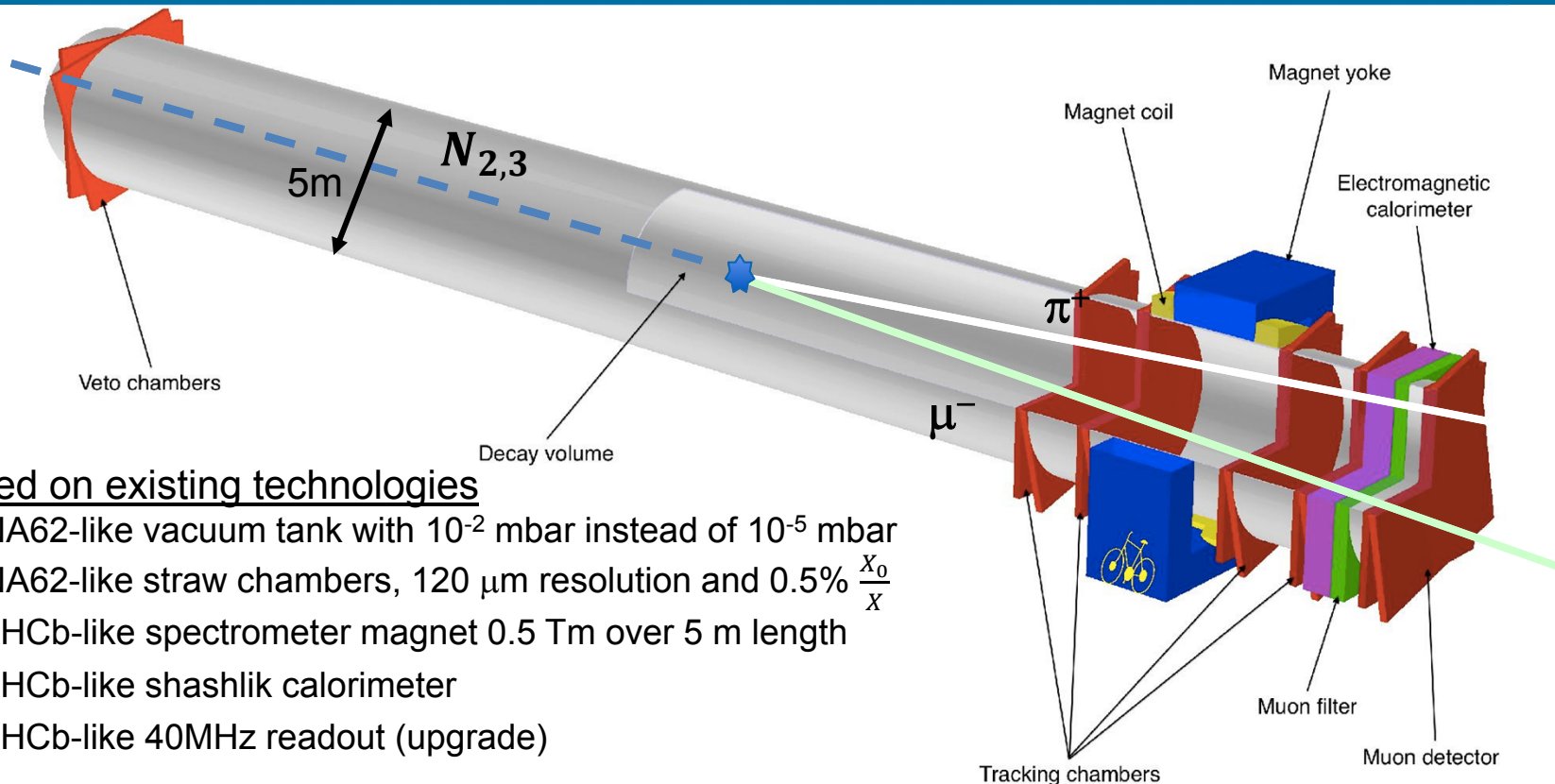

Based on existing technologies

- NA62-like vacuum tank with 10^{-2} mbar instead of 10^{-5} mbar
- NA62-like straw chambers, 120 μm resolution and $0.5\% \frac{X_0}{X}$
- LHCb-like spectrometer magnet 0.5 Tm over 5 m length
- LHCb-like shashlik calorimeter
- LHCb-like 40MHz readout (upgrade)

Detector Concept

- Geometric acceptance

- Saturates for a given $N_{2,3}$ lifetime as a function of the detector length
- The use of two magnetic spectrometers increases the acceptance by 70%
- Detector has two almost identical elements

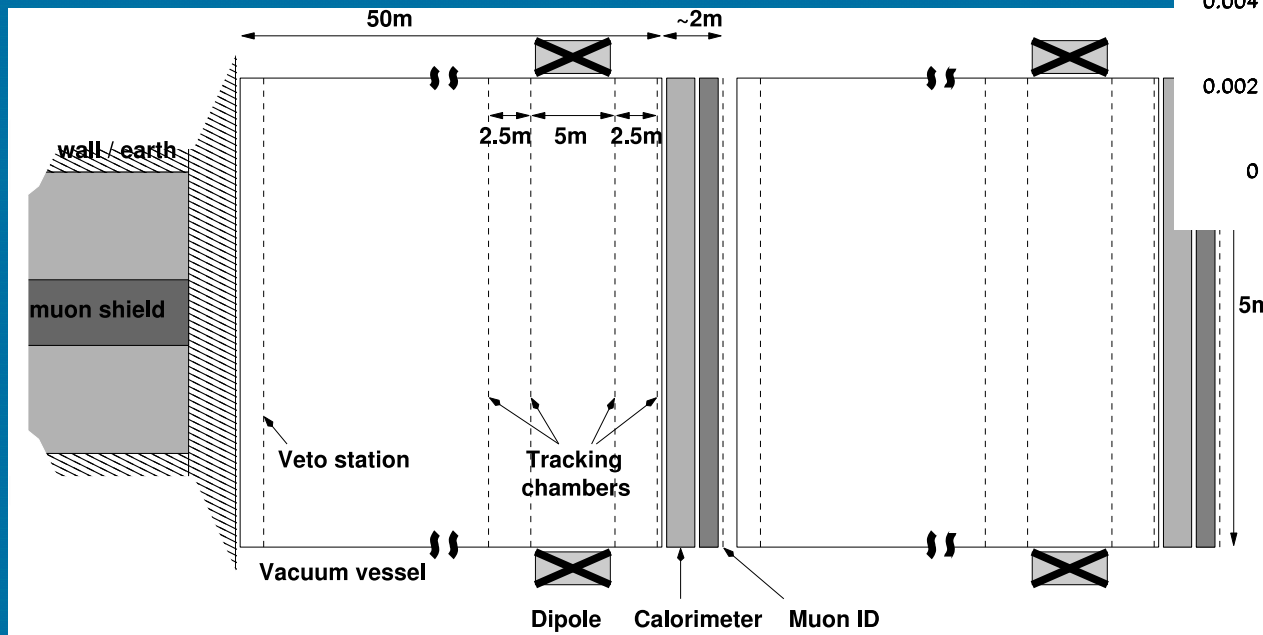
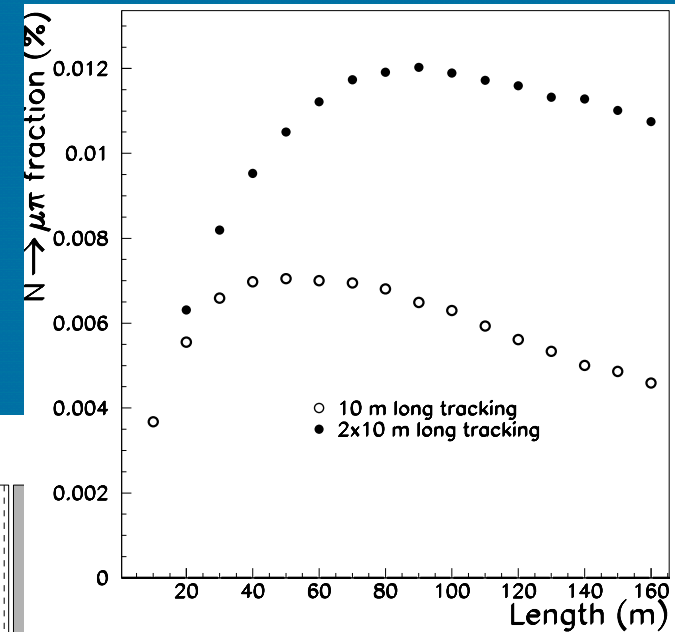



Residual Backgrounds

- Momentum spectrum of the neutrino flux after the muon shield

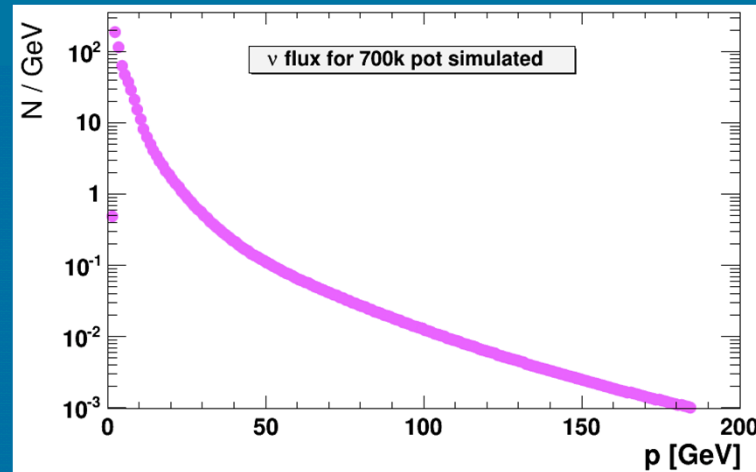

- 2×10^4 neutrino interactions per 2×10^{20} protons on target in the decay volume at atmospheric pressure
- Becomes negligible at 0.01 mbar

- Charged Current and Neutral Current neutrino interaction in the final part of the muon shield

- Simulated with GEANT and GENIE, and cross-checked with CHARM measurement
- Yields CC(NC) rate of $\sim 6(2) \times 10^5 / \lambda_{\text{inter}} / 2 \times 10^{20}$ p.o.t.
- $\sim 10\%$ of neutrino interactions produce Λ or K^0 in acceptance
- Majority of decays occur in the first 5 m of the decay volume
- Requiring μ -identification for one of the two decay products: 150 two-prong vertices in 2×10^{20} p.o.t.
- Instrumentation of the end-part of the muon shield allows the rate of CC + NC to be measured and neutrino interactions to be tagged

Residual Background

Background reduction by mass

- For 0.5 Tm field integral $\sigma_{\text{mass}} \sim 40$ MeV for $p < 20$ GeV
- 75% of $\mu\pi$ decay products have both tracks with $p < 20$ GeV

Reconstruction of $N_{2,3}$
with mass of 1 GeV

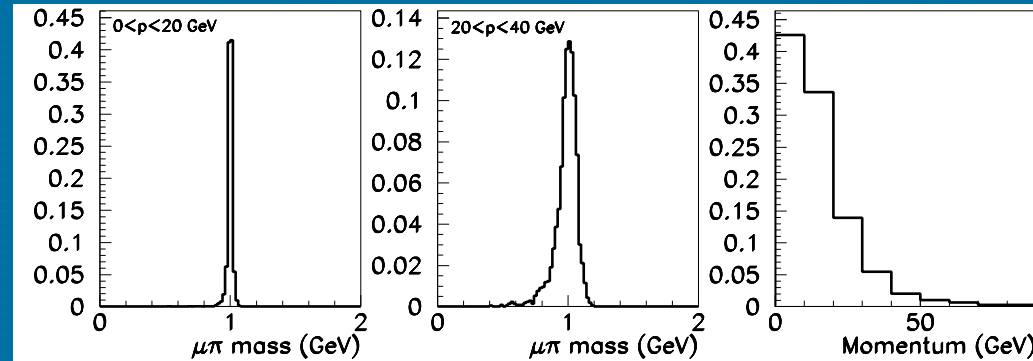

→ Ample discrimination between high mass tail from small number of residual $K_L \rightarrow \pi\mu\nu$ and $N_{2,3}$ @ 1 GeV

Background reduction by impact parameter

- K_L produced in the final part of the muon shield have significant impact parameter

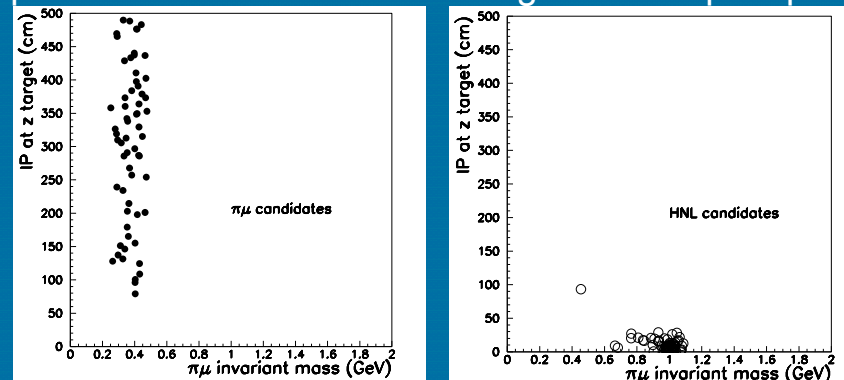

- $IP < 1$ m is 100% eff. for signal and leaves only a handful of background events (no mass cut)
- The IP cut will also be used to reject backgrounds induced in neutrino interactions in the material surrounding the detector, cosmics etc



Expected Event Yield $N_{2,3} \rightarrow \mu\pi$

- ◉ Integral mixing angle $\mathcal{U}^2 = \mathcal{U}_e^2 + \mathcal{U}_\mu^2 + \mathcal{U}_\tau^2$
- ◉ A conservative estimate of the sensitivity is obtained by considering only the decay $N_{2,3} \rightarrow \mu\pi$ with production mechanism $D \rightarrow \mu N_{2,3} X$, which probes \mathcal{U}_μ^4
- ◉ Expected number of signal events

$$N_{signal} = n_{pot} \times 2\chi_{cc} \times Br(\mathcal{U}_\mu^2) \times \varepsilon_{det}(\mathcal{U}_\mu^2)$$

$$n_{pot} = 2 \times 10^{20}$$

$$\chi_{cc} = 0.45 \times 10^{-3}$$

- $Br(\mathcal{U}_\mu^2) = Br(D \rightarrow \mu N_{2,3} X) \times Br(N_{2,3} \rightarrow \mu\pi)$ is assumed to be 20%
- $\varepsilon_{det}(\mathcal{U}_\mu^2)$ is the probability that $N_{2,3}$ decays in the fiducial volume, and μ and π are reconstructed
→ Detection efficiency entirely dominated by the geometrical acceptance

Expected Event Yield $N_{2,3} \rightarrow \mu\pi$

- For comparison, assume
 - $U_\mu^2 = 10^{-7}$ (corresponding to the strongest current experimental limit for $M_{N_{2,3}} = 1 \text{ GeV}$)
 - $\tau_N = 1.8 \times 10^{-5} \text{ s}$
- $\rightarrow \sim 12\text{k}$ fully reconstructed $N_{2,3} \rightarrow \mu\pi$ events are expected for $M_{N_{2,3}} = 1 \text{ GeV}$

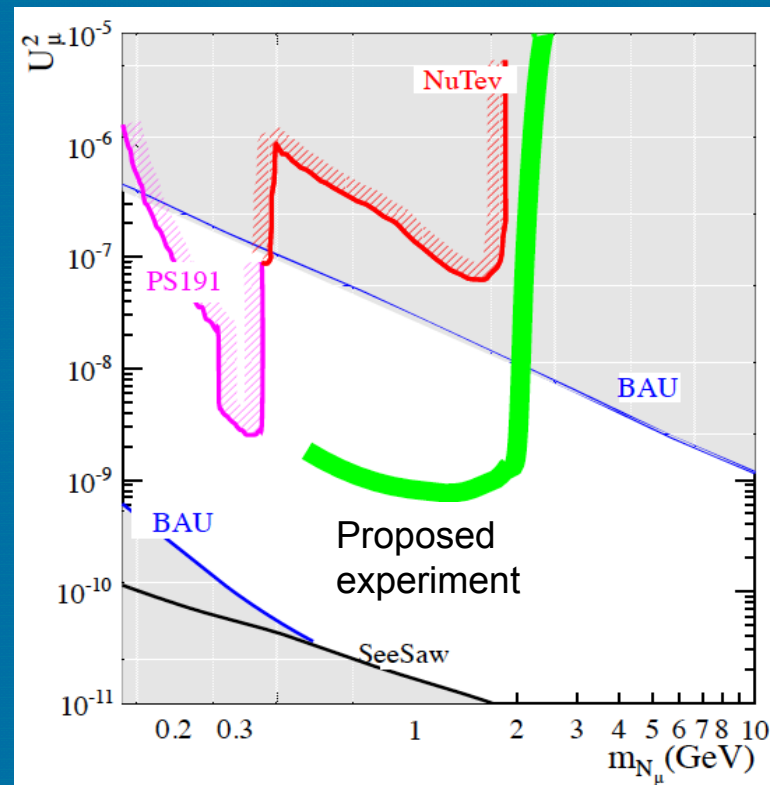

- 120 events for cosmologically favoured region: $U_\mu^2 = 10^{-8}$ and $\tau_N = 1.8 \times 10^{-4} \text{ s}$

Efficiency for $N_{2,3} \rightarrow e\pi, \mu\rho$

- Calorimeter will allow reconstruction of additional decay modes
 - $N_{2,3} \rightarrow \mu^\mp \rho^\pm, \rho^\pm \rightarrow \pi^\pm \pi^0$
 - $N_{2,3} \rightarrow e\pi$ allow probing \mathcal{U}_e^2
- Assume $\mathcal{U}_\mu^2 = 10^{-7}$ and $\tau_N = 1.8 \times 10^{-5} s$ for mass $M_{N_{2,3}} = 1 GeV$

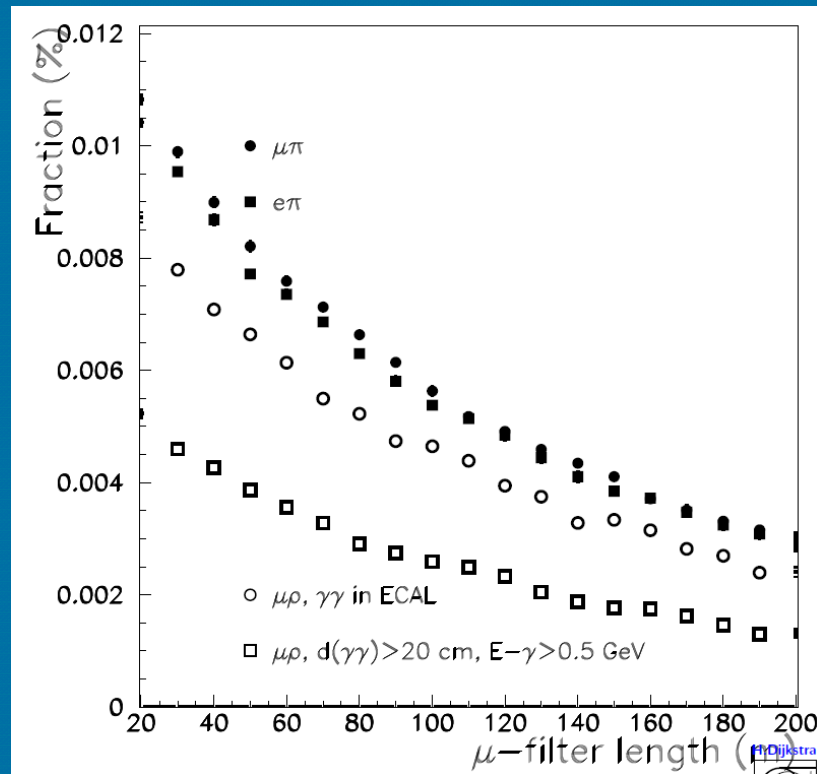

- Reconstruction efficiency for $N_{2,3} \rightarrow \mu\rho$ is 45% of efficiency for $N_{2,3} \rightarrow \mu\pi$

Conclusions

- Power of ν MSM “framework”
 - Minimal SM extension with solutions to the main BSM questions with *least prejudice*
 - Origin of the baryon asymmetry of the Universe
 - Origin of neutrino oscillations and mass
 - Shed light on the nature of Dark Matter
 - Many observable predictions in both accelerator based experiments and cosmological observations
 - A well constrained parameter space!

- For $M_N < 2 \text{ GeV}$ and 2×10^{20} p.o.t. the proposed experiment has discovery potential for the cosmologically favoured region with $10^{-7} < \mathcal{U}_\mu^2 < a \text{ few} \times 10^{-9}$ for the decay $N_{2,3} \rightarrow \mu\pi$
 - May be improved with additional decay modes
 - $N_{2,3} \rightarrow e\pi$ allow probing \mathcal{U}_e^2

- The impact of a discovery of the HNLs on particle physics is difficult to overestimate !

- *Experiment also sensitive to other predictions of new, very weakly interacting and long-lived particles with masses below the Fermi scale*

- The proposed experiment perfectly complements the searches for NP at the LHC



Conclusions

- Proposal presented to the CERN SPS Committee on October 22, 2013

- Very well received
- Follow-up questions being discussed with referees
- Evaluation in progress

- Proposal being discussed with:

European Organization for Nuclear Research (CERN)

France: CEA Saclay, APC/LPNHE Universite Paris-Diderot

Italy: Istituto Nazionale di Fisica Nucleare (INFN)

Netherlands: National Institute for Subatomic Physics (NIKHEF, Amsterdam)

Poland: Henryk Niewodniczanski Institute of Nuclear Physics Polish Academy of Sciences (Kracow)

Russia: Institute for Nuclear Research of Russian Academy of Science (INR, Moscow),
Institute for Theoretical and Experimental Physics ((ITEP, Moscow),
Joint Institute for Nuclear Research (JINR, Dubna)

Sweden: Stockholm University,
Uppsala University

Switzerland: Ecole Polytechnique Federale de Lausanne (EPFL),
University of Zurich,
University of Geneva

UK: University of Oxford,
University of Liverpool,
Imperial College London,
University of Warwick

➔ Open to further interest from new groups



High Energy Physics in the LHC Era

Search for Heavy Neutral Leptons

Abstract:

A minimal extension of the Standard Model with three right-handed singlet Majorana leptons with masses below the Fermi scale (ν MSSM) allows incorporating a mechanism to generate the baryon asymmetry of the Universe, account for the pattern of small neutrino masses and oscillations, and potentially provide a Dark Matter candidate. This avoids introducing new energy scales between the Fermi scale and the Planck scale, the lack of which has also been shown to be compatible with the mass of the recently discovered Higgs boson. Considerations based on cosmological constraints and based on the data on neutrino oscillations favour a range of masses and couplings for these new heavy neutral leptons (HNL) which is largely accessible to experimental verification or falsification.

This paper outlines a proposal for a new fixed-target experiment at the CERN SPS to search for the HNLs, together with an introduction to the theoretical motivation, a description of the experimental setup with the associated beam line and detector, and a discussion of the background sources and the expected sensitivity. With an integrated total of 2×10^{20} protons on target at 400 GeV, the experiment is able to achieve a sensitivity which is four orders of magnitude better than previous searches. In addition to HNLs, the experiment will be sensitive to many other types of physics models that predict weakly interacting long-lived exotic particles.



Reserve slides



CERN Accelerator Complex

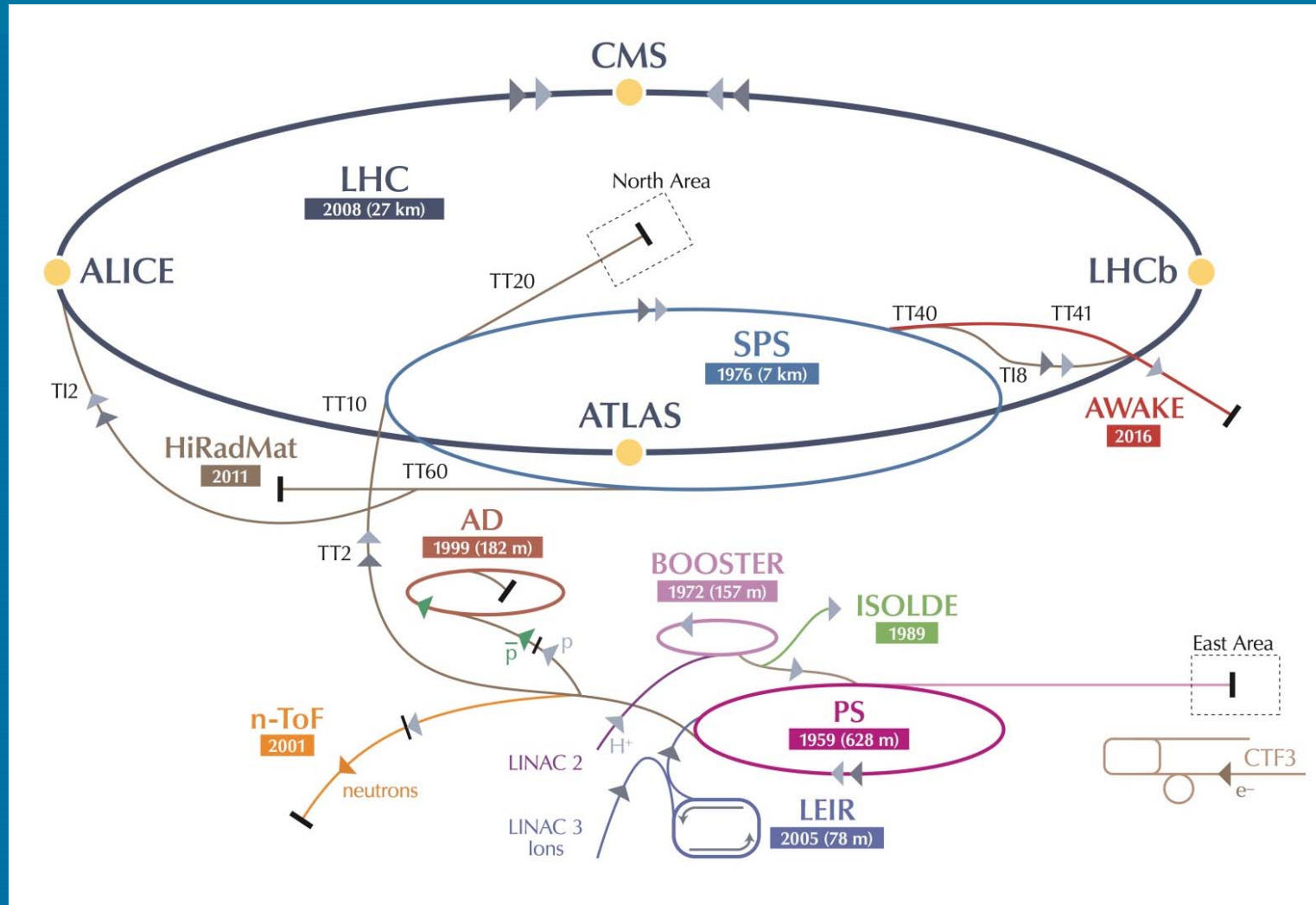

Detector Technologies

- Experiment requires a dipole magnet similar to LHCb design, but with $\sim 40\%$ less iron and three times less dissipated power
- Free aperture of $\sim 16 \text{ m}^2$ and field integral of $\sim 0.5 \text{ Tm}$
 - Yoke outer dimension: $8.0 \times 7.5 \times 2.5 \text{ m}^3$
 - Two Al-99.7 coils
 - Peak field $\sim 0.2 \text{ T}$
 - Field integral $\sim 0.5 \text{ Tm}$ over 5 m length

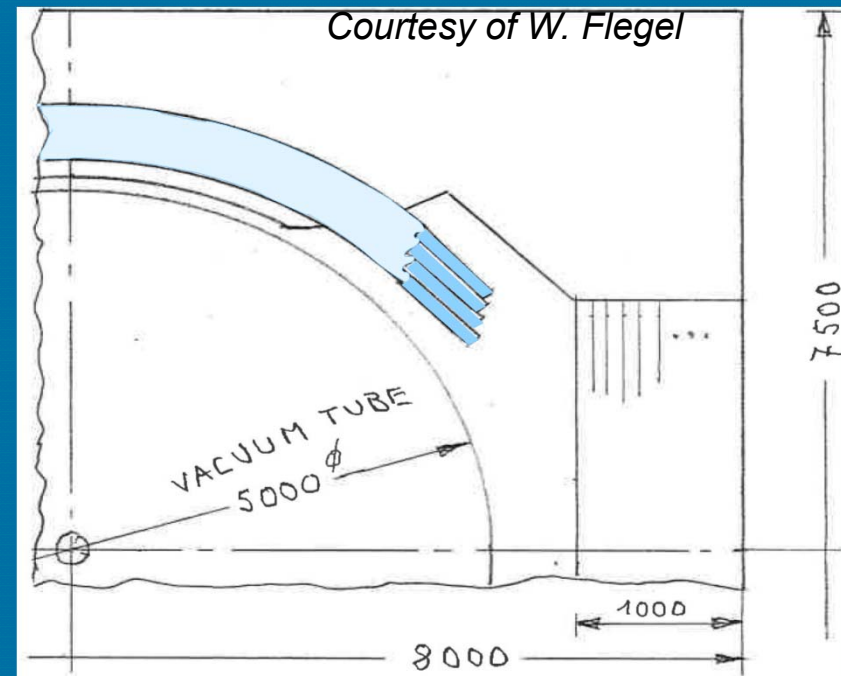



Detector Technologies

- NA62 vacuum tank and straw tracker
 - $< 10^{-5}$ mbar pressure in NA62 tank (cmp. 10^{-2} mbar)
 - Straw tubes with $120 \mu\text{m}$ resolution and $0.5\% \frac{X_0}{X}$ of material budget
 - Gas tightness of straw tubes demonstrated in long term tests
- Multiple scattering and spatial resolution of straw tubes give similar contribution to the overall $\frac{dP}{P}$

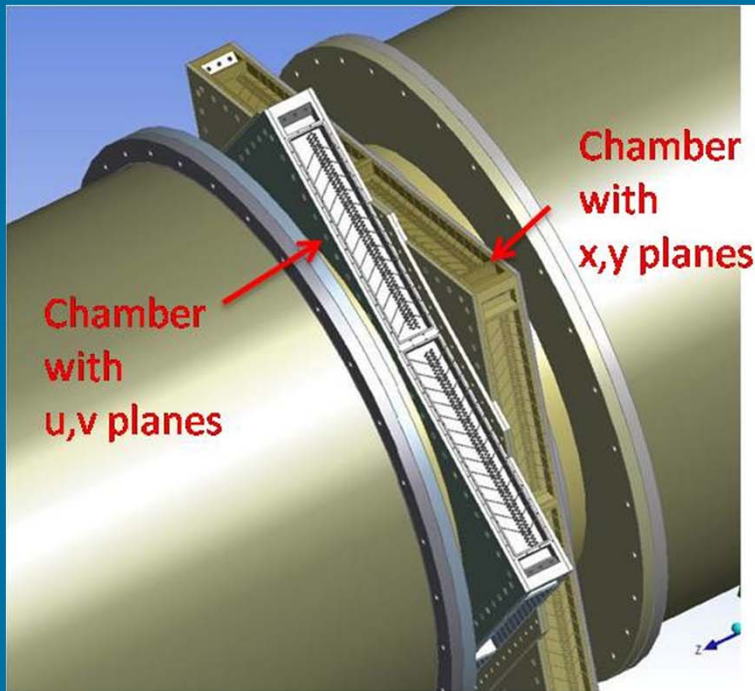
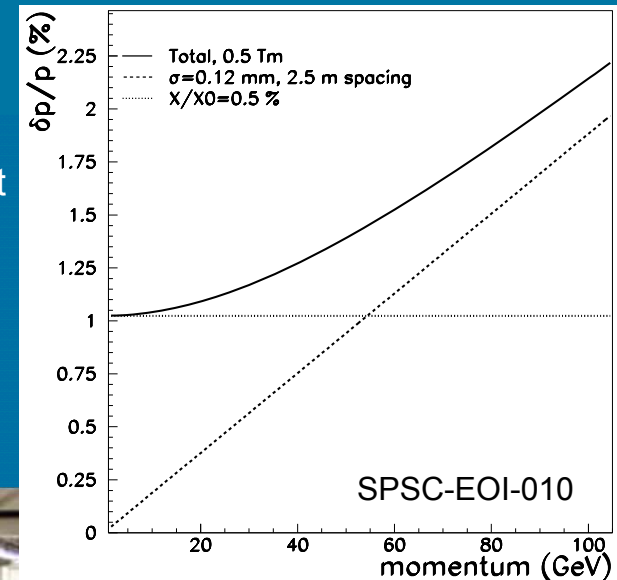



Detector Technologies

- LHCb electromagnetic calorimeter
- Shashlik technology provides economical solution with good energy and time resolution

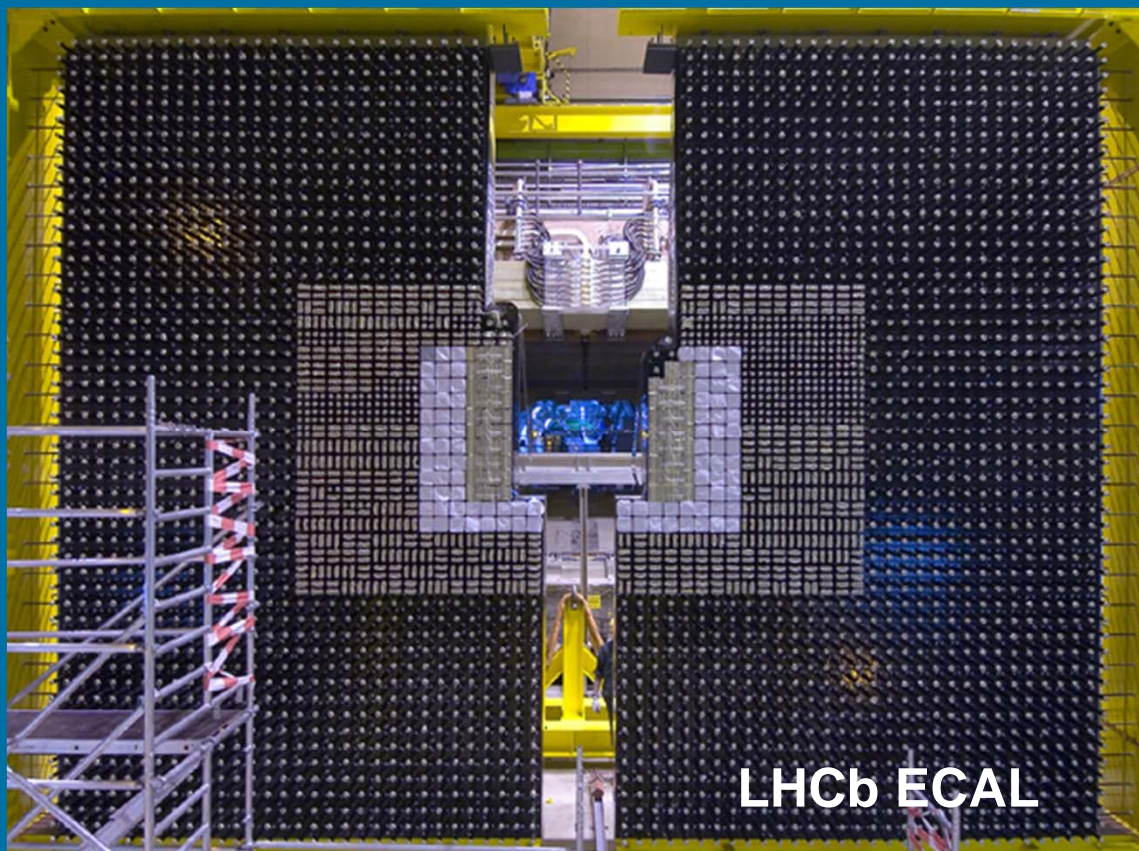

Constraints in Variants of ν MSM

1. ν MSM: HNLs are required to explain neutrino masses, BAU, and DM
 - \mathcal{U}^2 is the most constrained
2. HNLs are required to explain neutrino masses and BAU
 - N_1 , N_2 and N_3 are available to produce neutrino oscillations/masses and BAU
3. HNLs are required to explain neutrino masses
 - Only experimental constraints remain
4. HNLs are required to explain Dark Matter
5. HNLs are helpful in cosmology and astrophysics
 - E.g. HNL may influence primordial abundance of light elements
 - E.g. HNL with masses below 250 MeV can facilitate the explosions of the supernovae
- ◉ HNLs are not required to explain anything - just so
 - Contributions of the HNL to the rare lepton number violating processes $\mu \rightarrow e$, $\mu \rightarrow eee$

