



Present baseline of HL-LHC integration

C. Adorisio, R. Bruce, M. Brugger, R. Calaga, O. Capatina, F. Cerutti,
S. Chemly, C. Collazos Gonzales, J.P. Corso, R. De Maria, D. Duarte
Ramos, L. S. Esposito, P. Fessia, H. Mainaud Durand, Y. Muttoni,
H. Prin, S. Redaelli T. Renaglia, E. Todesco
S. Roesler, S. Weisz

Presented by

P. Fessia

Outline:

- Magnet system, LHC vs. HL-LHC
- Crab cavity
- Alignment
- SC links
- Collimation
- Conclusions and next steps

Remark:

the integration effort has just started and it is putting in evidence challenges.

Due to time and rapid evolution of reference baseline we do not have yet solutions for all of them

IP1 and IP5

INTERACTION REGION MAGNET SYSTEM

IR where ?

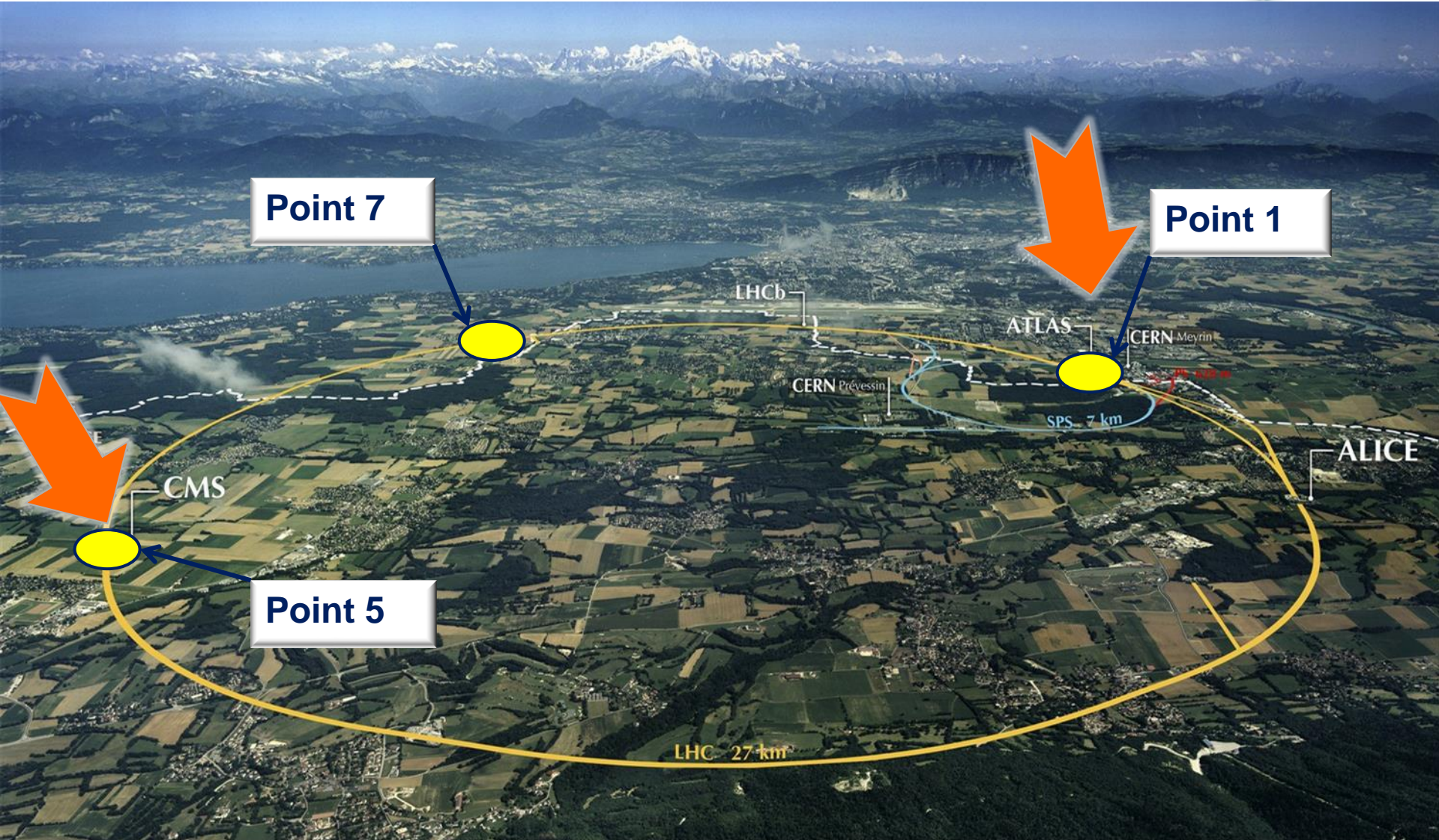

From concept to *virtual reality*

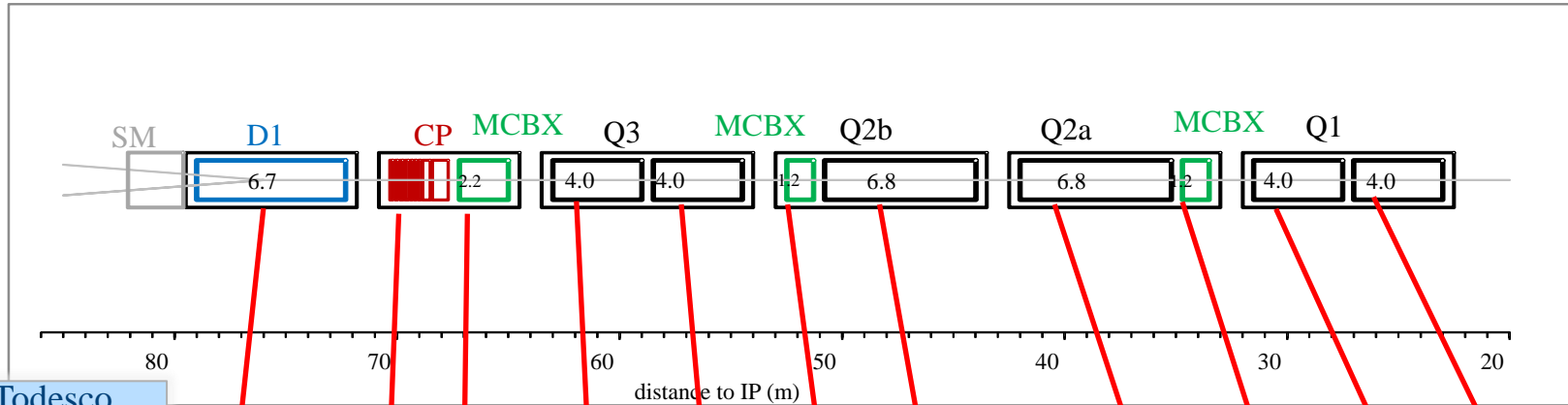

E. Todesco

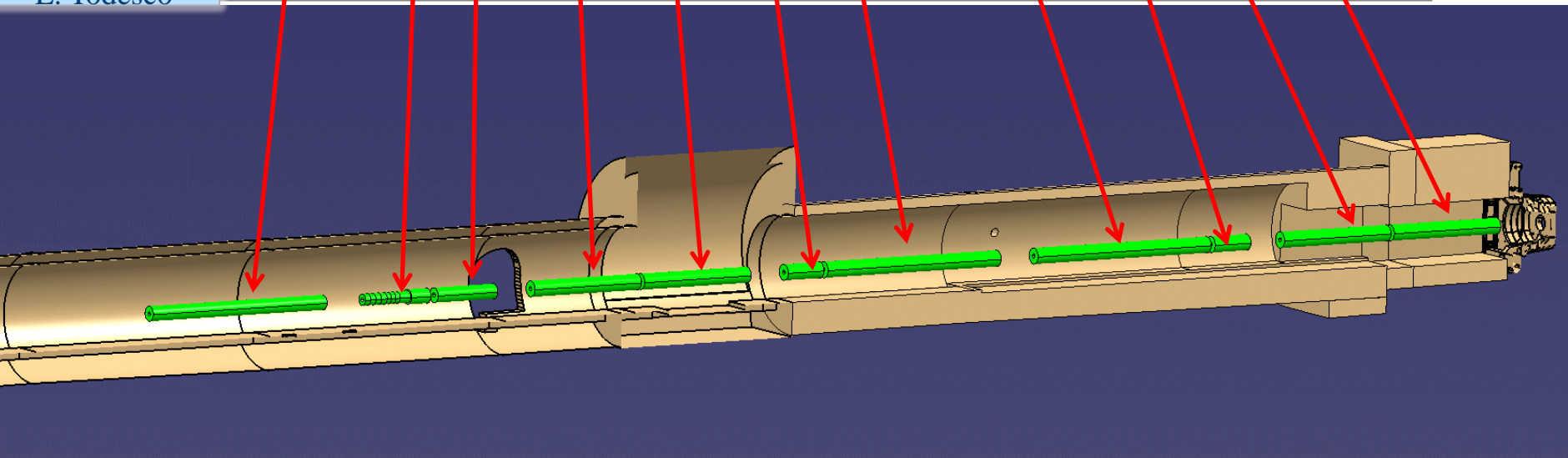

The LHC vs. HL-LHC

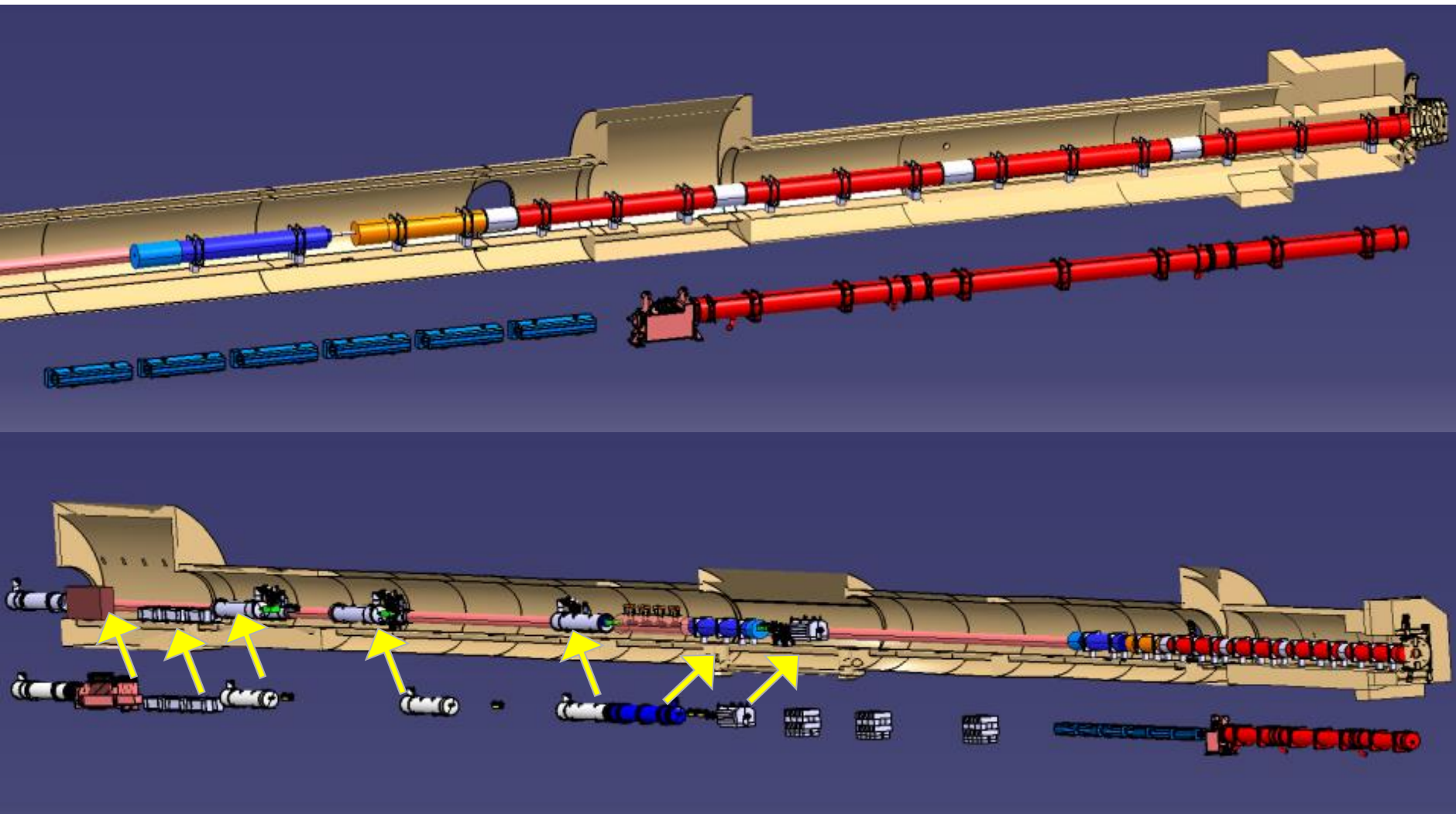

3D models are, at this stage, a simplification of reality...

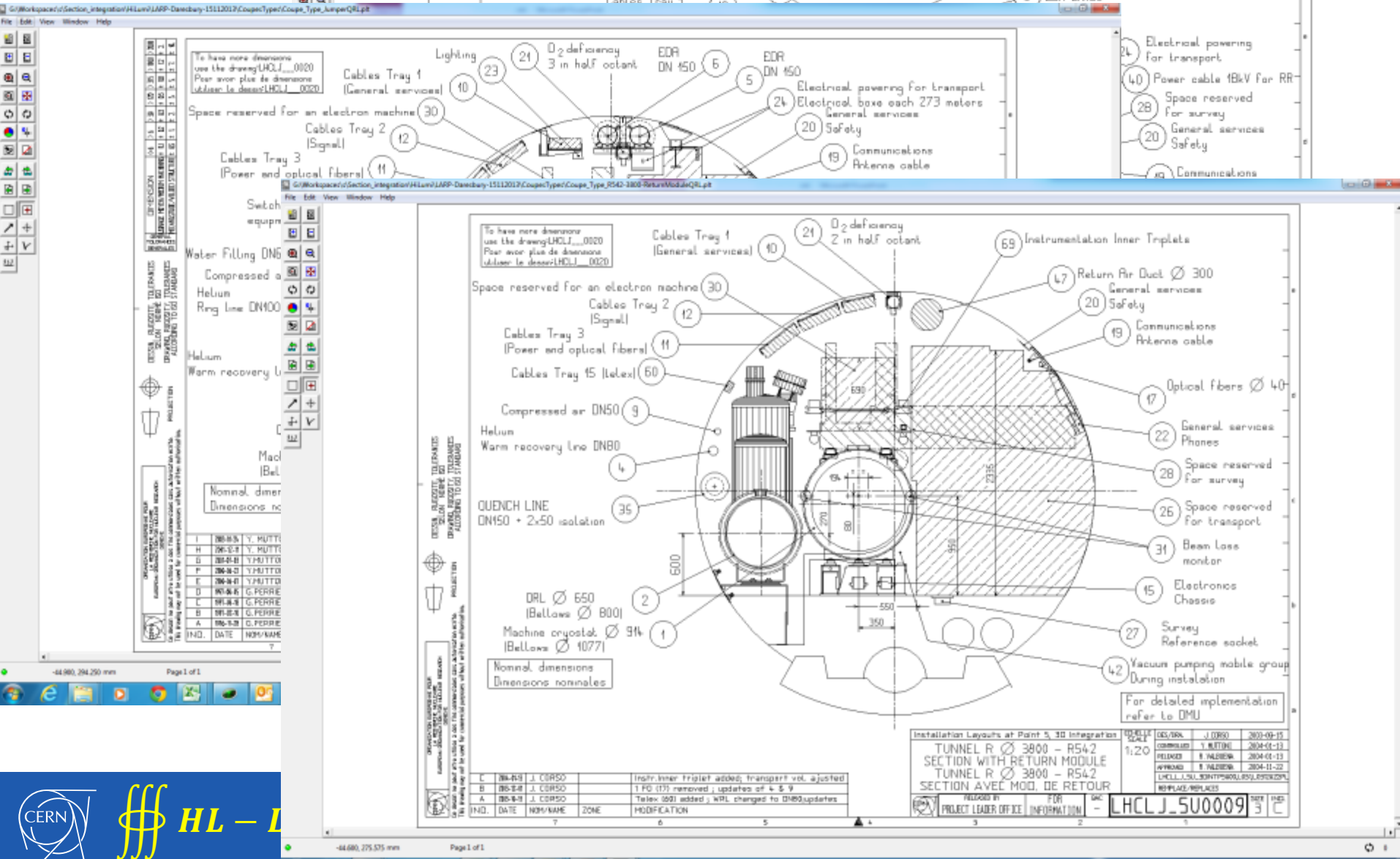

The image displays a CAD software interface showing two technical drawings of a tunnel section. The drawings include various components like cable trays, quench lines, and instrumentation, with callouts and dimensions. A legend and revision table are also visible.

Top Drawing: Shows a cross-section of a tunnel with components labeled: Cables Tray 1 (General services), Cables Tray 2 (Signal), Cables Tray 3 (Power and optical fibers), Lighting, O₂ deficiency 3 in half octant, EDR DN 150, EDR DN 150, Electrical powering for transport, Electrical boxes each 273 meters, General services, Safety, Communications, Antenna cable, Space reserved for an electron machine, and EDR DN 150.

Bottom Drawing: Shows a more detailed cross-section of a tunnel with components labeled: Cables Tray 1 (General services), Cables Tray 2 (Signal), Cables Tray 3 (Power and optical fibers), Cables Tray 15 (Telcel), Compressed air DN 50, Helium Warm recovery line DN 80, QUENCH LINE DN 150 + 2x50 isolation, DRL Ø 650 (Bellows Ø 800), Machine cryostat Ø 914 (Bellows Ø 1077), Instrumentation Inner Triplets, Return Air Duct Ø 300, Safety, Communications Antenna cable, Optical fibers Ø 40, General services, Phones, Space reserved for survey, Space reserved for transport, Beam Loss monitor, Electronics Chassis, Survey Reference socket, Vacuum pumping mobile group During installation, and For detailed implementation refer to DMU.

Legend:

- Water Filling DN6
- Compressed air
- Helium Ring Line DN 100
- Helium Warm recovery line
- MacI
- IBel
- Nominal dimensions

Revision Table:

IND.	DATE	NOM/NAME	MODIFICATION
C	2004-04-13	J. CORSO	Ingr Inner triplet added; transport vol. adjusted
B	2004-04-13	J. CORSO	1 FD (17) removed; updates of 4 & 9
A	2004-04-13	J. CORSO	Telcel 691 added; WRL changed to DM9 updates

Project Information:

Installation Layouts at Point 5, 3D Integration
TUNNEL R Ø 3800 - R542
SECTION WITH RETURN MODULE
TUNNEL R Ø 3800 - R542
SECTION AVEC MOD. DE RETOUR

SCALE: 1:20
PROJECT LEADER OFFICE INFORMATION: LHCLJ_SU0009

The contractual document

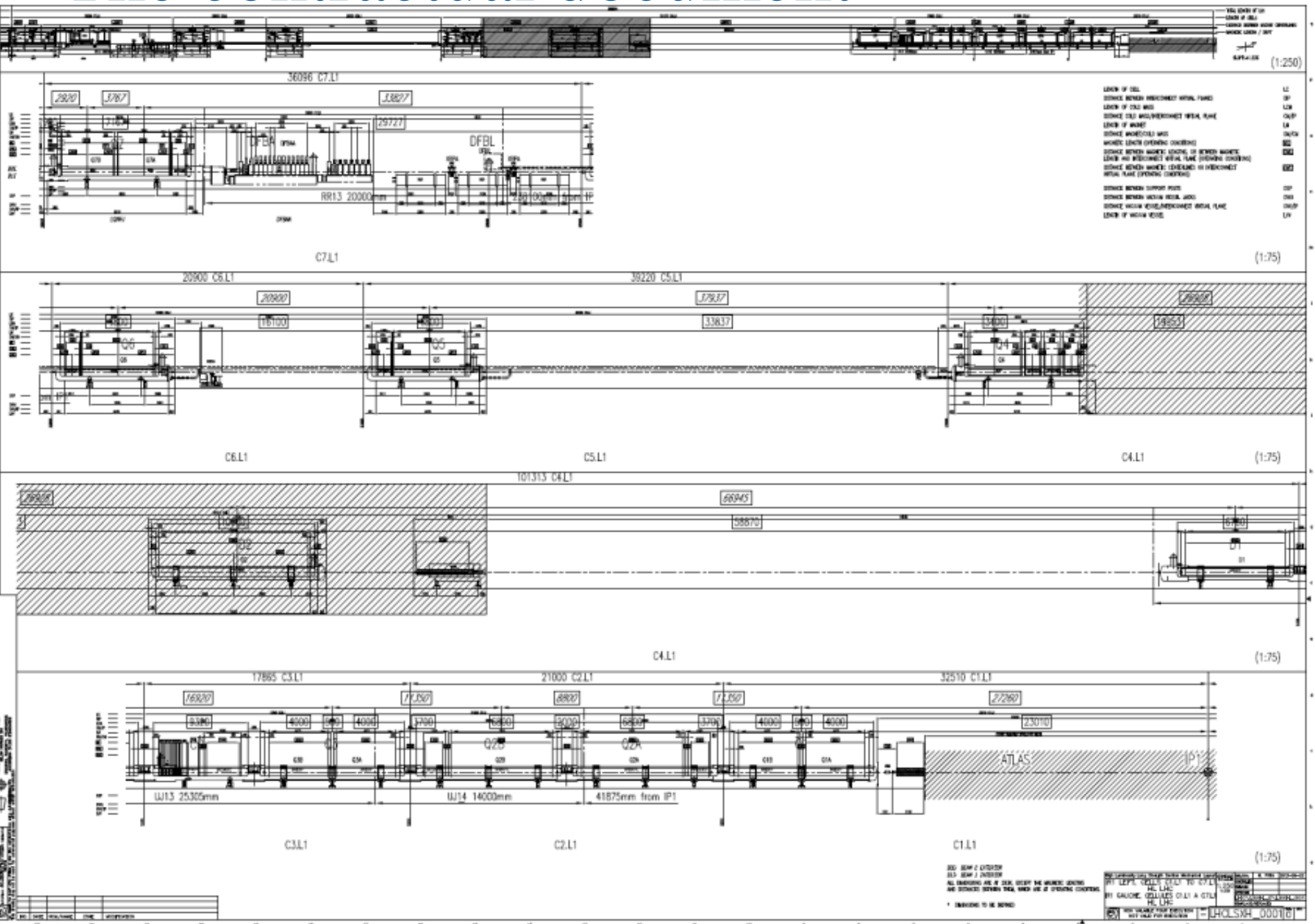

Cryostat system

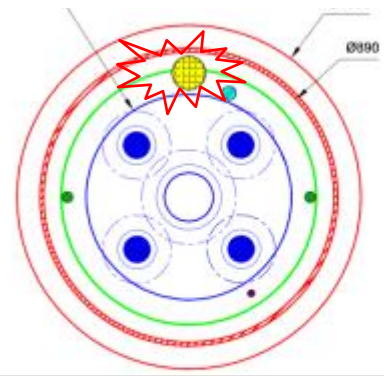
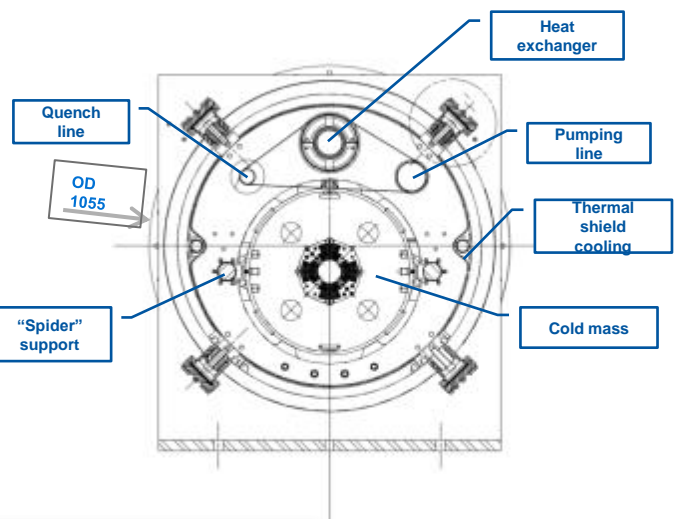

Standard cryostat diameter no solution to accommodate all manifolds

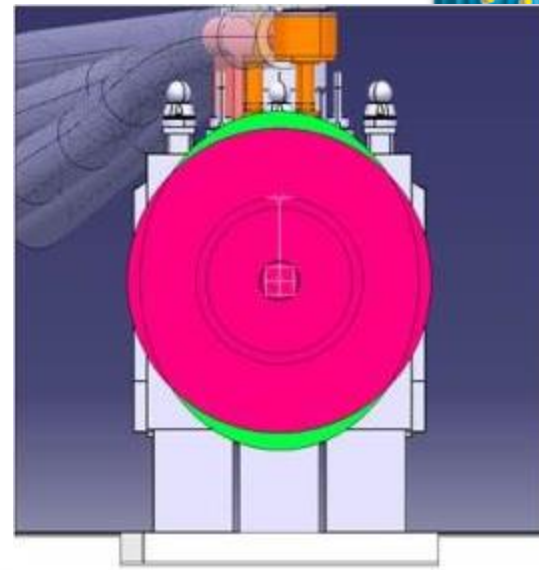

D. Duarte Ramos

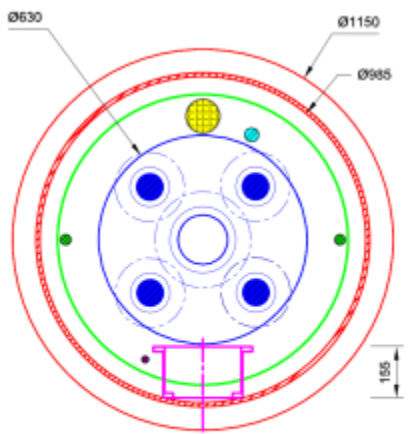

Larger diameter cryostat, but compatible with transport space, feasible but issues (heat loads)

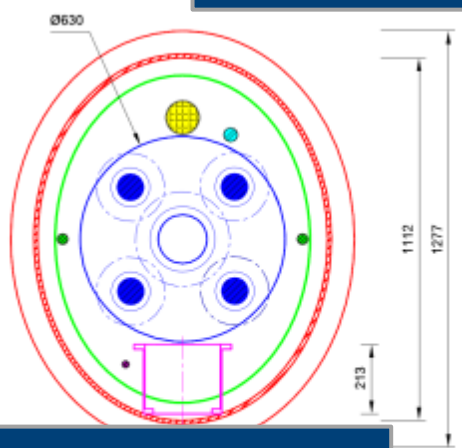

Elliptical cryostat. Very good accommodation but technological challenges



C

Residual radiation dose

FLUKA calculations for LS1 (1 week cooling)

Courtesy: C.Urscheler et al.

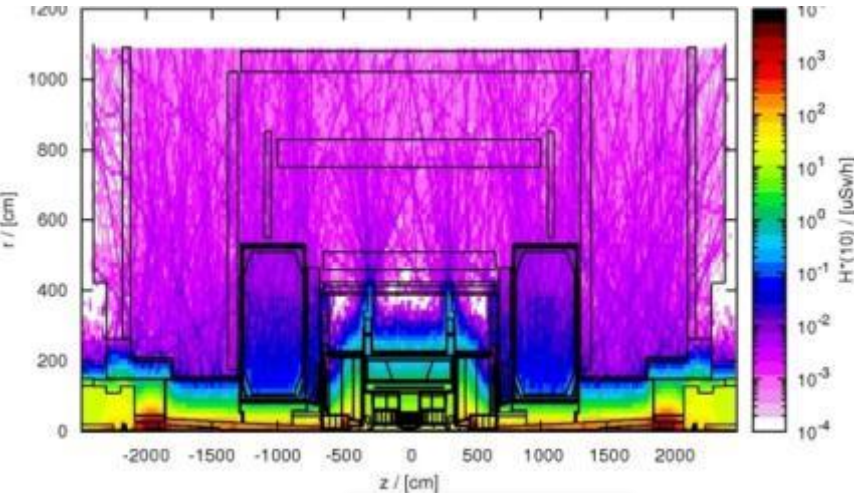

S. Roesler

Ambient dose equivalent rates in $\mu\text{Sv/h}$ at 40cm measured on Dec 17, 2012 (last “good” fill on Dec 5, i.e. cooling time >1 week)

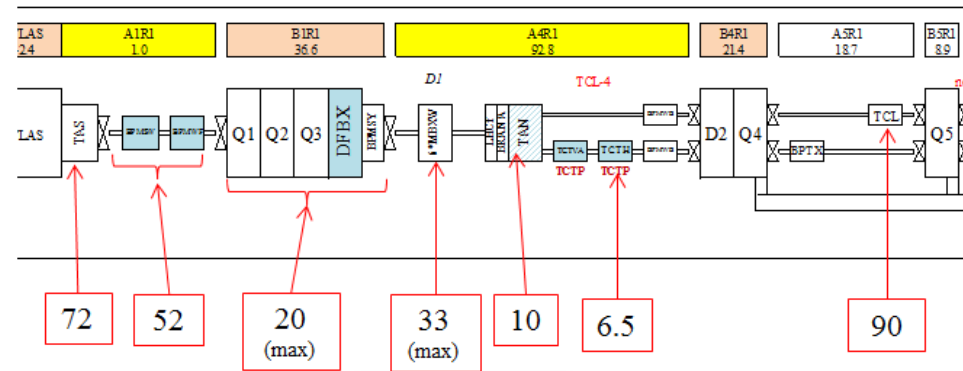

LS3



LS4

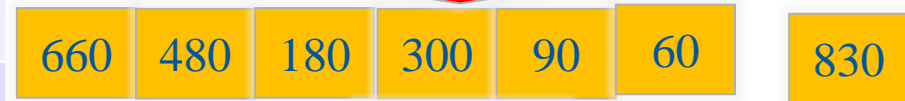

2035

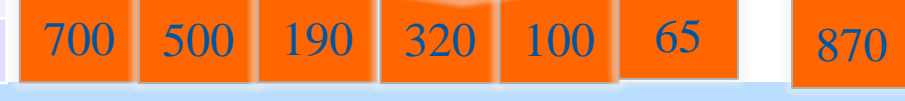

4 months cooling

	x/LS1	t_{cool}	Scaling factor
LS2	4.1	1 week	1.6
LS3	8.5	1 month	1.0
LS4	27.4	4 months	0.47
LS5	28.4	6 months	0.35
2035	28.8	1 year	0.2

“LSS1 and LSS5 will become Limited Stay Areas until LS3 with residual dose rates (few months cooling) in the aisle of about 100 $\mu\text{Sv/h}$, reaching several mSv/h close to most radioactive objects.” S. Roesler remote handling workshop

IP1 and IP5

CRAB CAVITY

4+4 BASELINE

SERVICE SPACE REQUIREMENT UNDER REVISION

BY CRAB CAVITY TEAM

Ancillary equipment needs

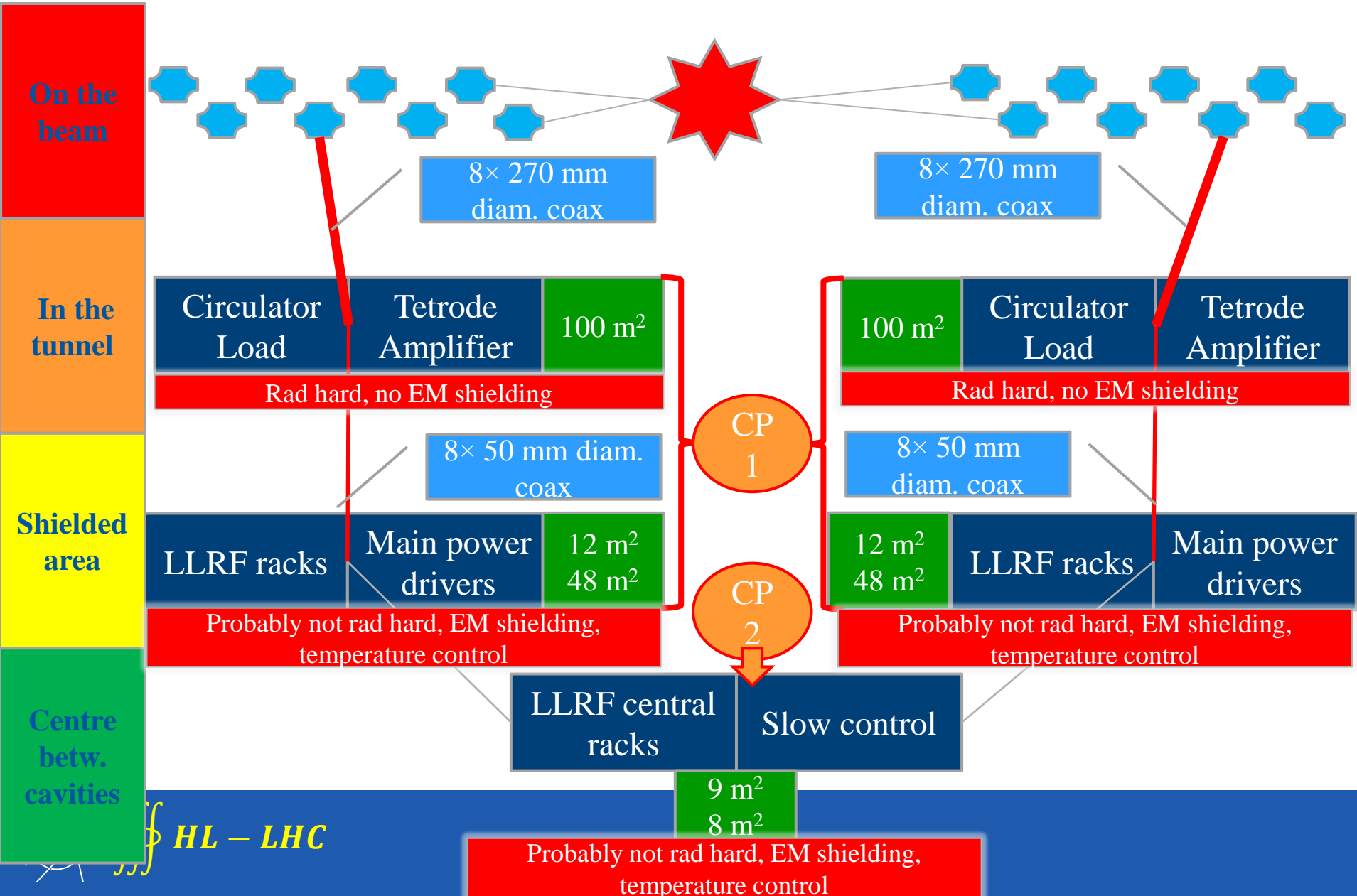

The 1st obvious option for CP1: RR

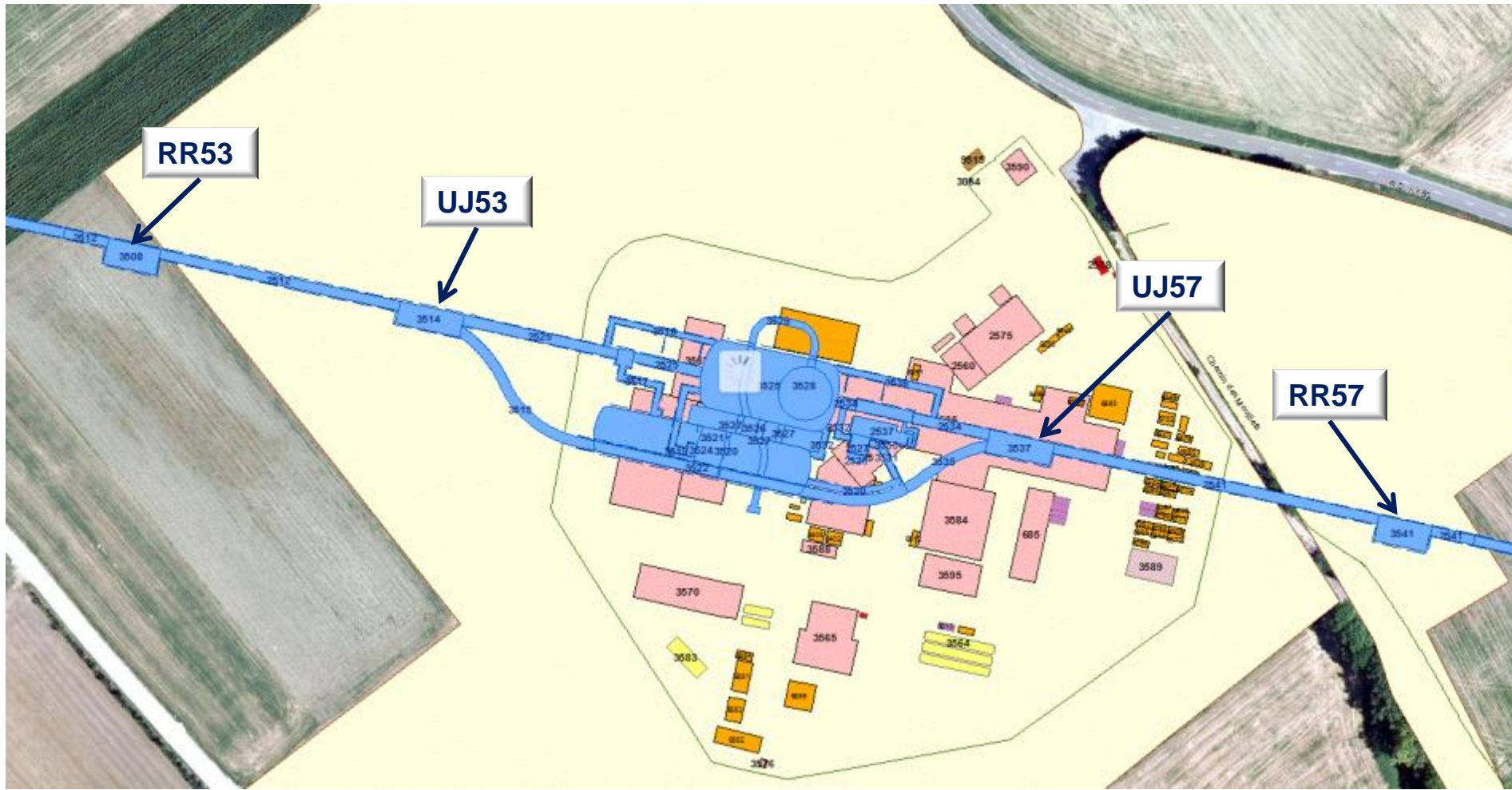

From crab to RR

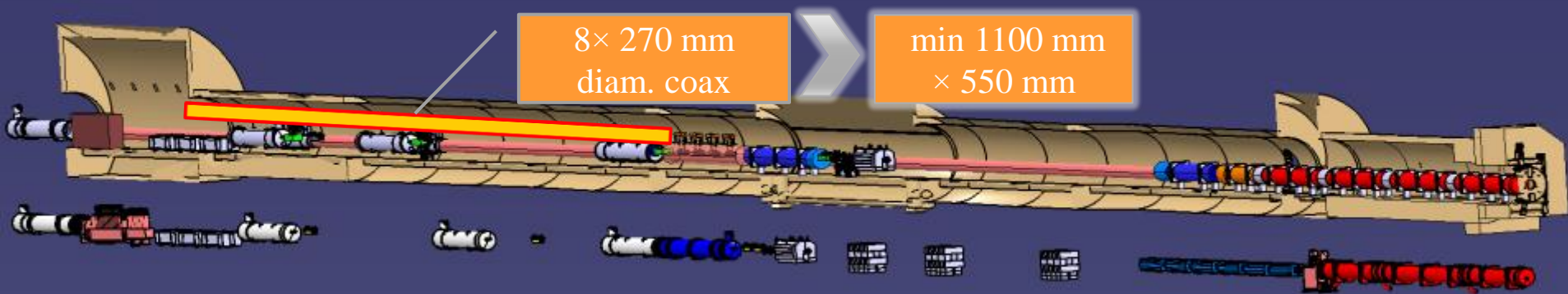
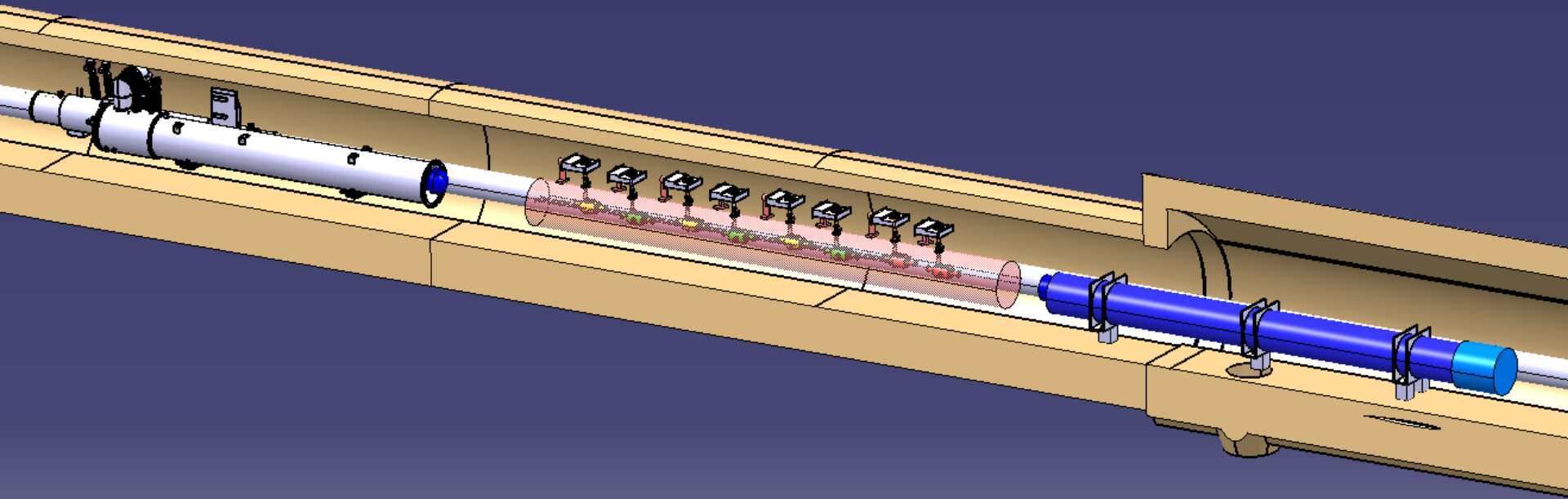

RR present occupancy



← RR ground floor

RR upper floor
↓

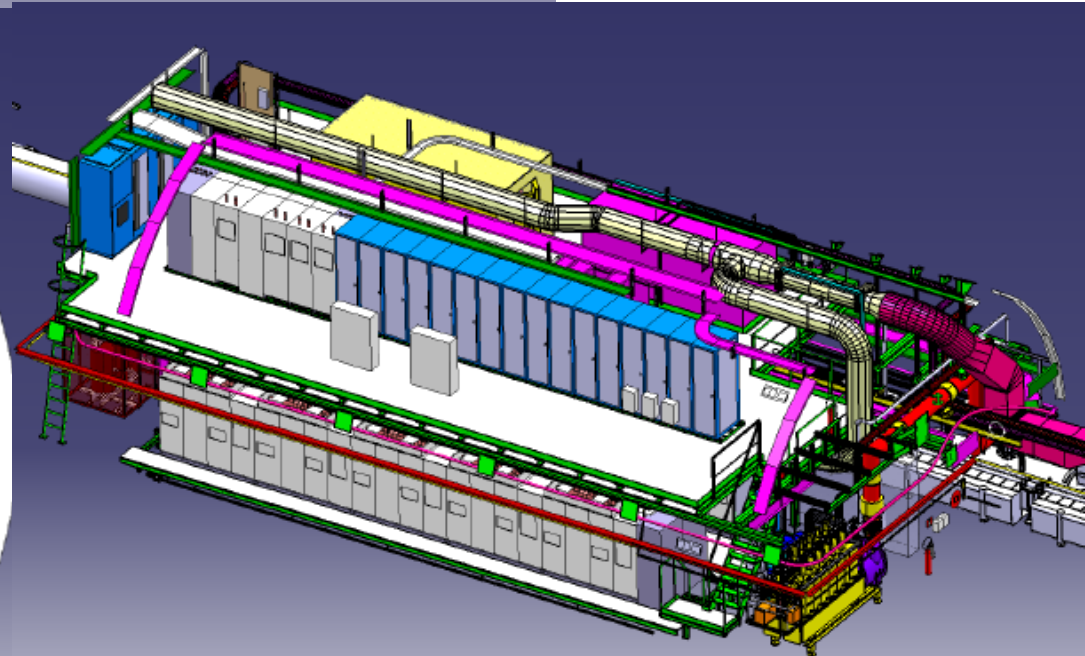
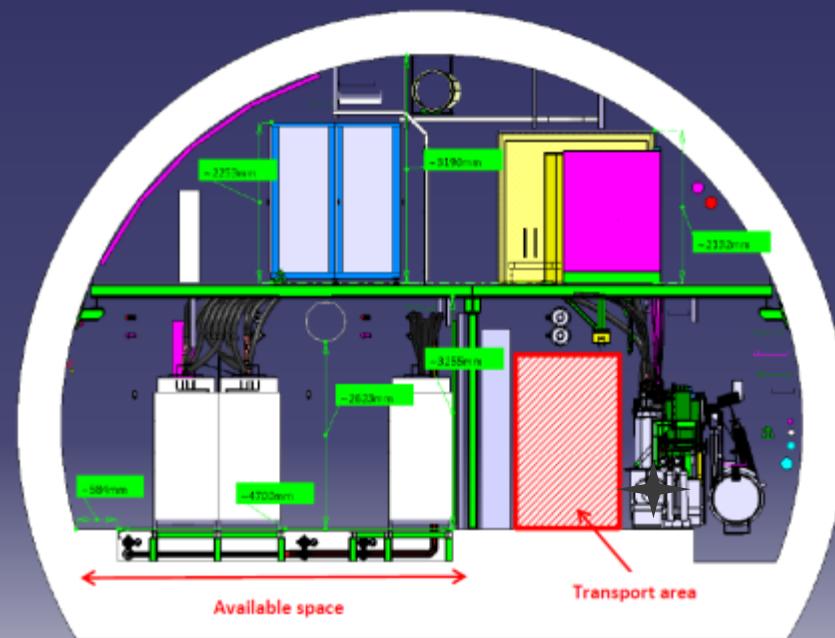

RR future occupancy with full SC link option

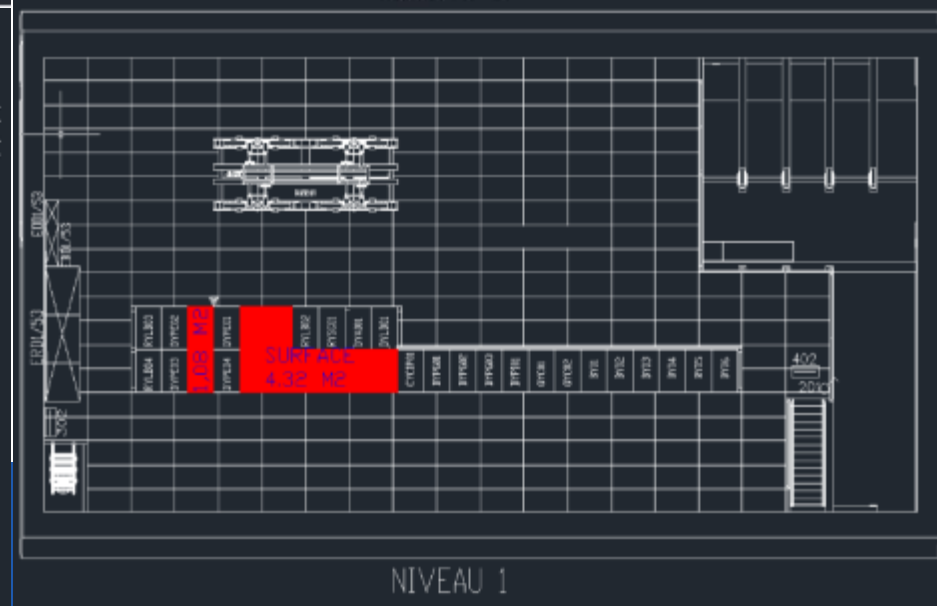
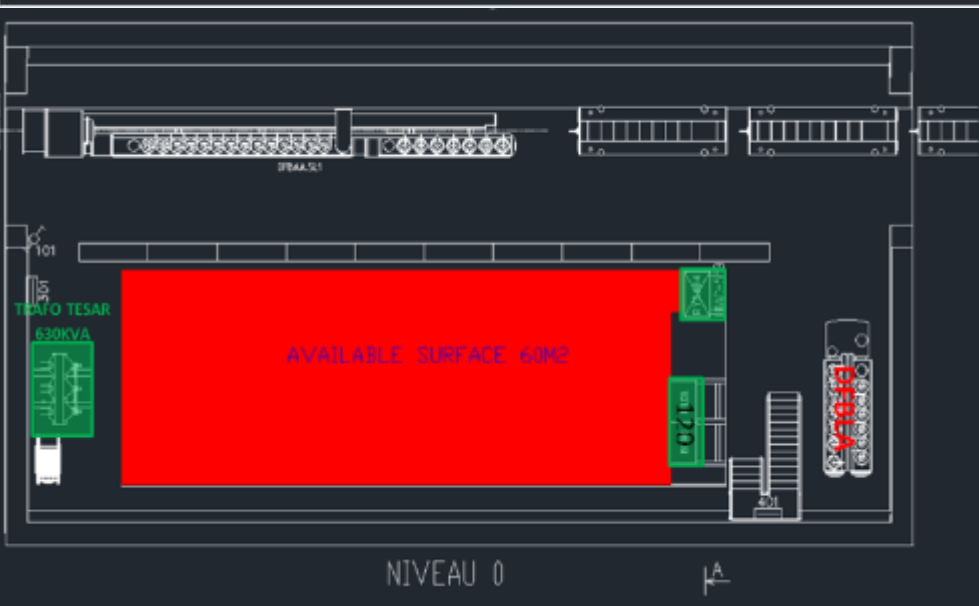
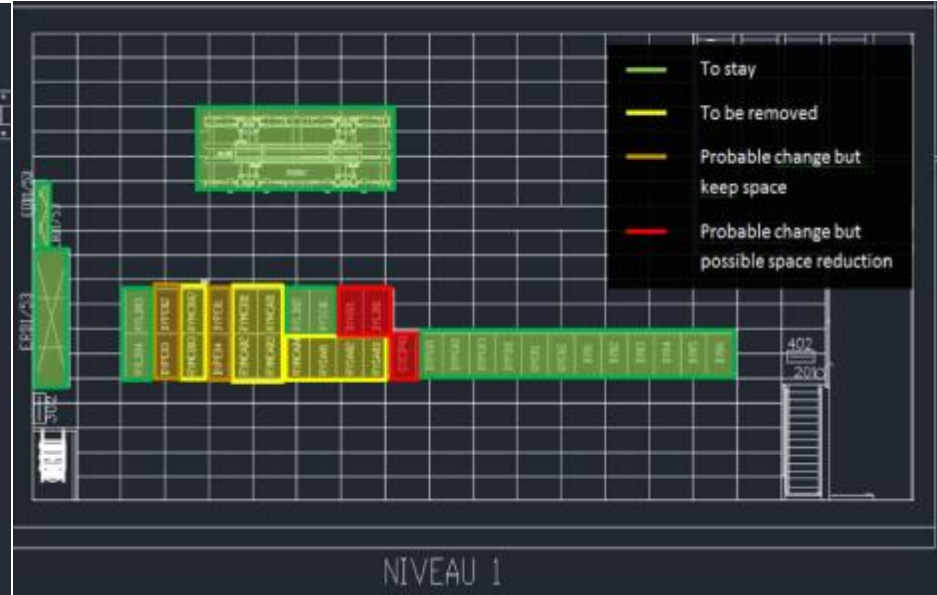
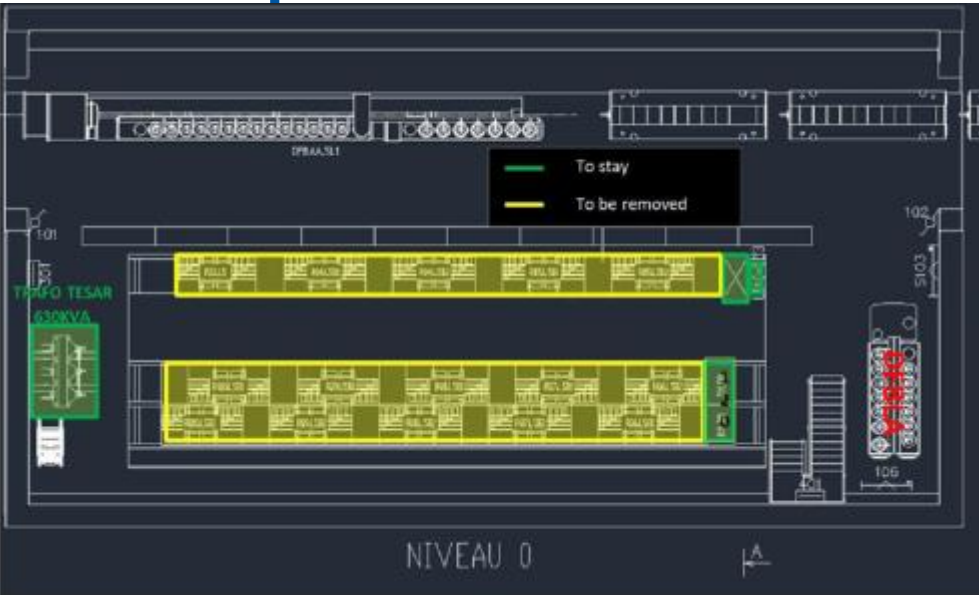

RR radiation wise in HL-LHC



perspective

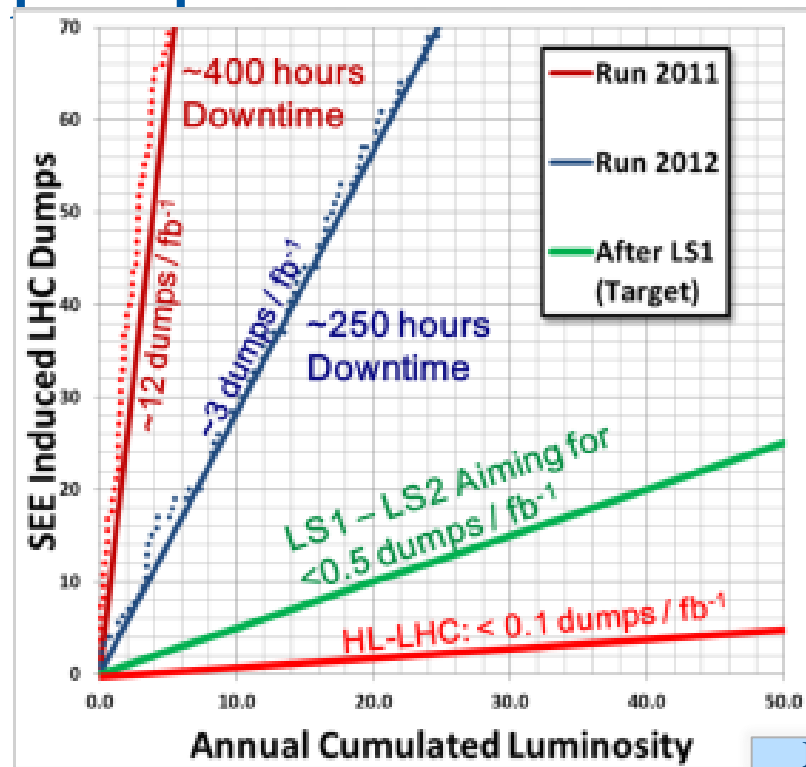

	$N_{b \text{ coll}}$ [10^{11}]	L_{peak} [10^{34} $\text{cm}^{-2}\text{s}^{-1}$]	L_{lev} [10^{34} $\text{cm}^{-2}\text{s}^{-1}$]	Lev. time [h]	Opt. Fill length [h]	η_{6h} [%]	η_{opt} [%]
HL-Flat	2.2	18.6	5.06	7.0	8.4	57.8	53.5
HL-Round	2.2	20.1	5.06	7.3	8.6	57.8	53.1

Figure of merit (performance efficiency η): fraction of physics time to reach goal with a sequence of successful fills with 3h turnaround time using both optimal fill length and 6h fill length (2012 run would figures with 53.5%).

M. Brugger

LHC Area	Prediction (HEH/cm ²)	Measured (HEH/cm ²)	Nominal (HEH/cm ²)	HL-LHC (HEH/cm ²)	HL-LHC (Dose/Gy)
UJ14/16	1.4E+08	1.6E+08	5E+08	3E+09	6
RR13/17	2.0E+08	2.5E+08	8E+08	5E+09	10
UJ56	1.6E+08	1.5E+08	5E+08	3E+09	6
RR53/57	2.0E+08	2.5E+08	8E+08	5E+09	10
UJ76	2.1E+07	6.0E+07	2E+08	1E+09	2
RR73/77	2.9E+07	5.0E+07	2E+08	1E+09	2
UX85B	4.3E+08	3.5E+08	4E+08	2E+09	4
US85	1.3E+08	8.8E+07	9E+07	4E+08	1

During last year of operation we had a number of radiation induced failures at $10^8 - 10^9 \text{ cm}^{-2} \text{ y}^{-1}$. According to R2E experience and analysis $10^7 \text{ cm}^{-2} \text{ y}^{-1}$ acceptable.

CP2 IP 1

UL14

US15

UL16

Available place LS3

Available place LS3

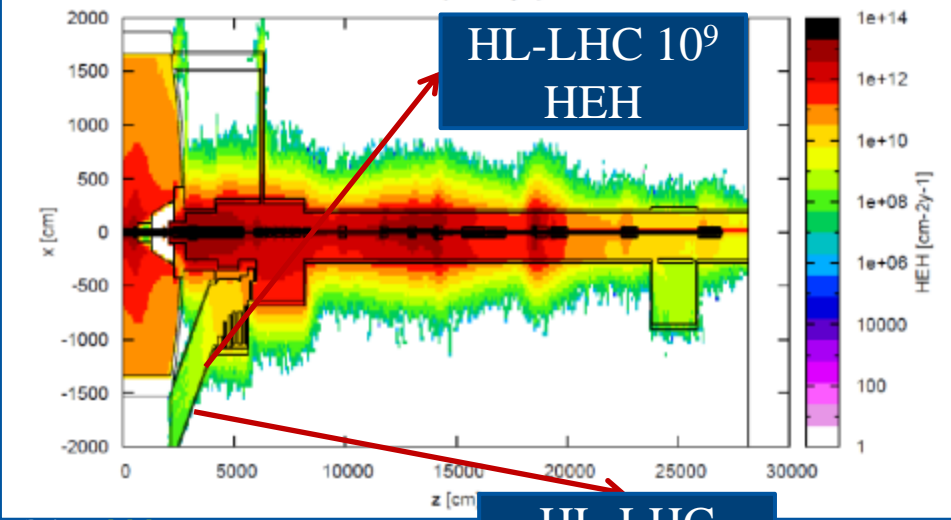

Equipment requires faraday cage and +/- 1° C control.
Necessary to find very compact solution.
Challenging but to be studied

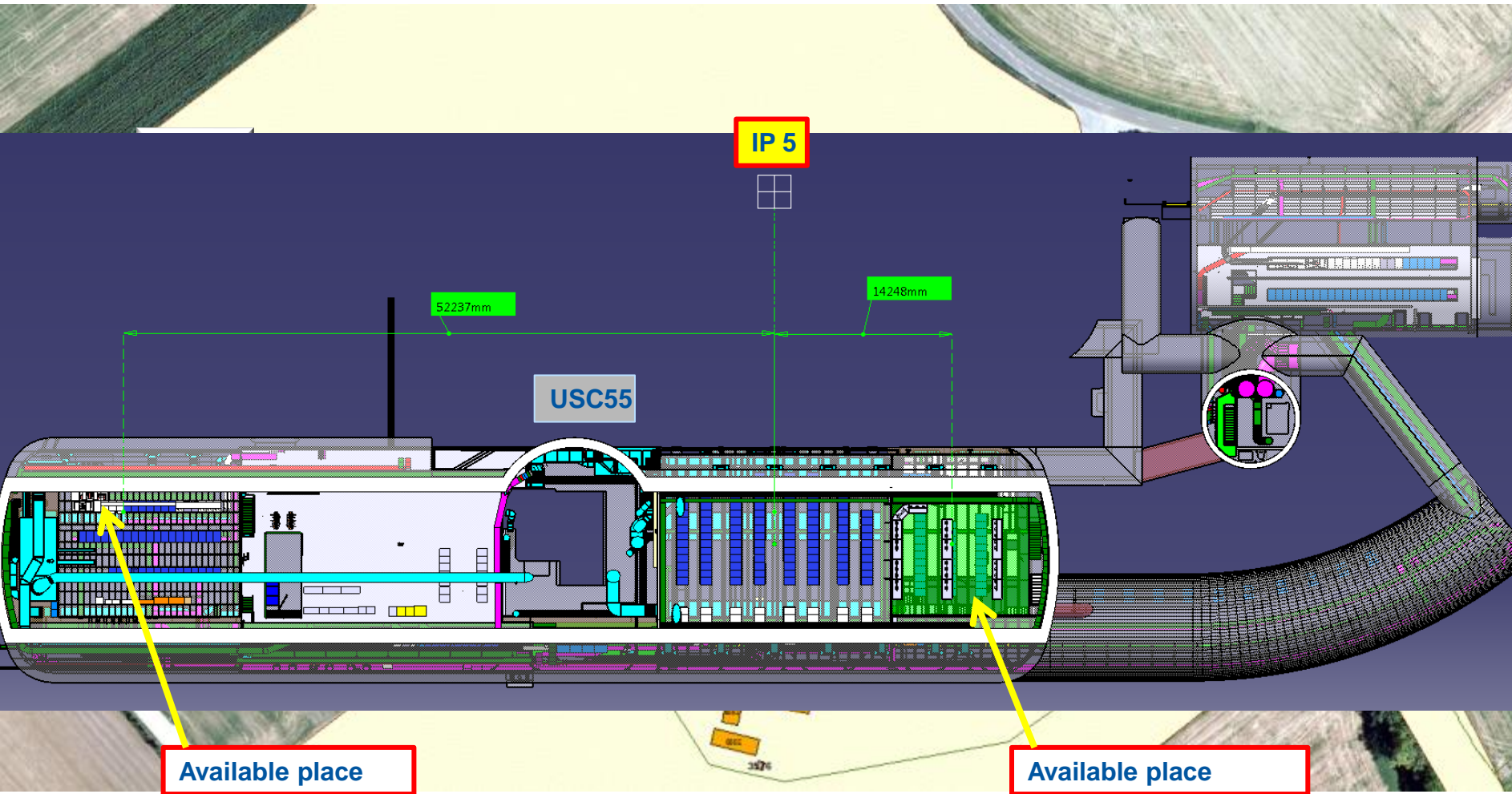

PC2 IP 5

Control Room (68m²)

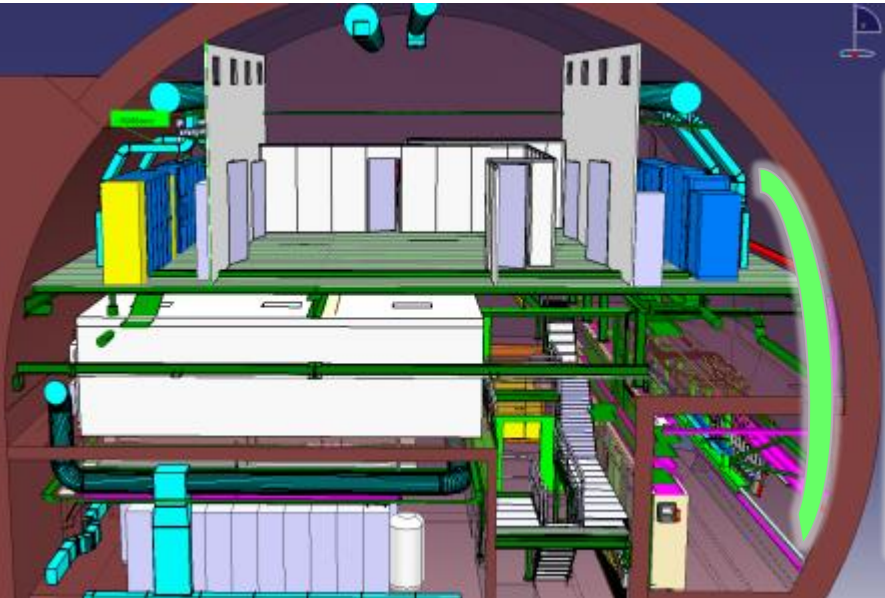
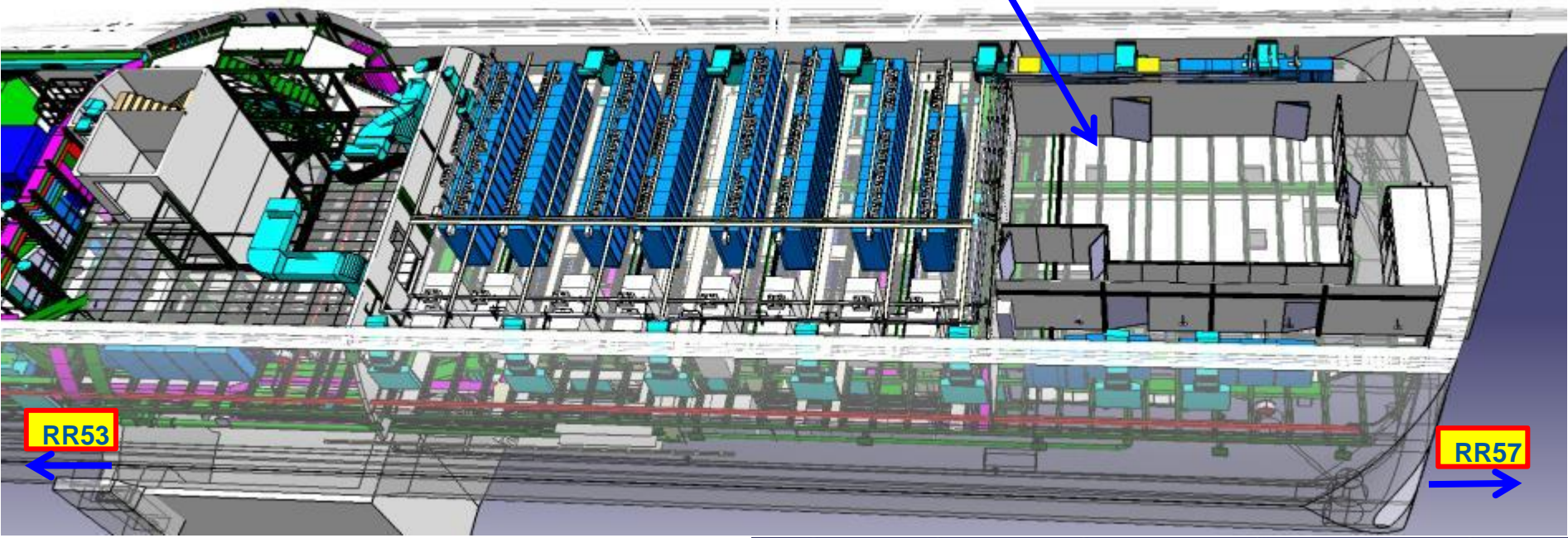

False floor option



Option to be discussed with CMS if ,after more in-depth,analysis, it would still be interesting

US15 – 3 reserve racks on 3rd level...by now

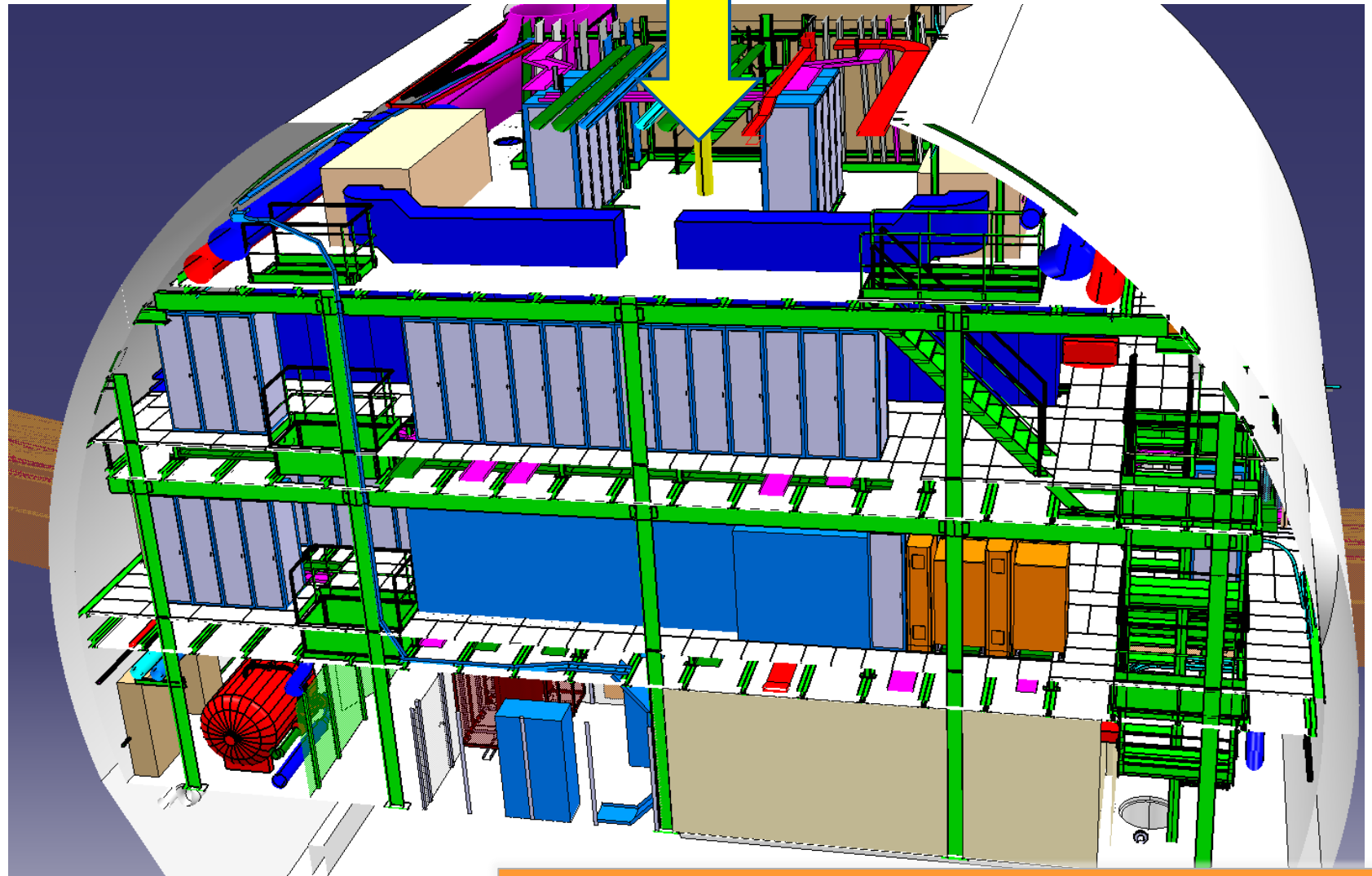

Option to be discussed with CMS if ,after more in-
depth,analysis, it would still be interesting



HL – LHC

IP1 and IP5

ALIGNMENT

*1ST APPROACH TO IDENTIFY MAJOR PROBLEMS,
REQUIRING RESTUDY TAKING INTO ACCOUNT
ACCESSIBILITY*

Horizontal alignment

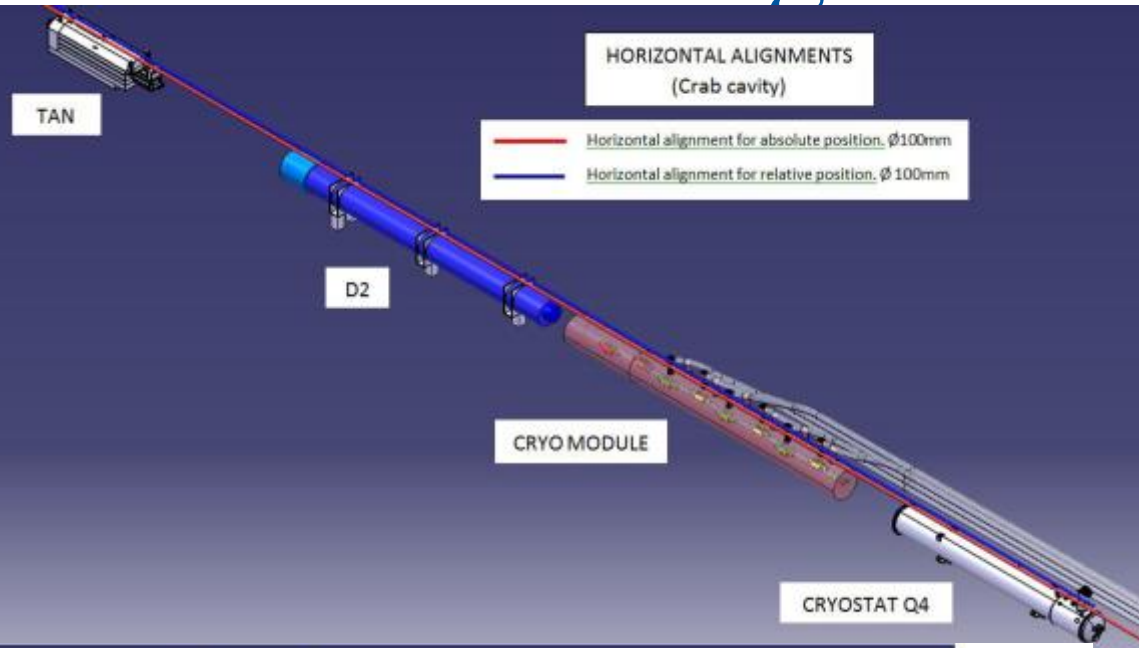

Horizontal alignment

Two systems

- 1) Reference for absolute position from Q1 till Q5
- 2) Reference for relative position from Q1 till Q4

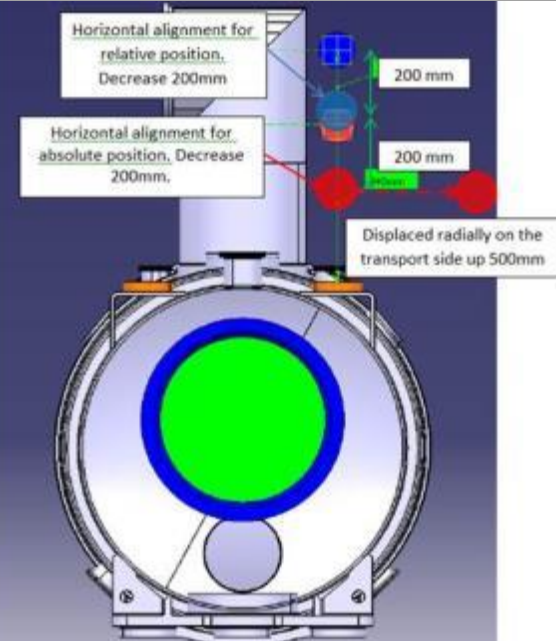
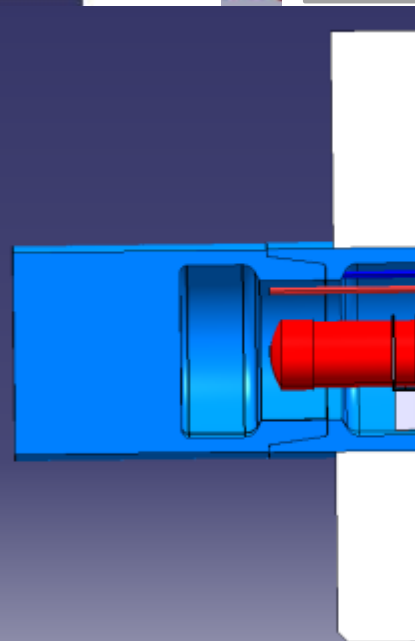
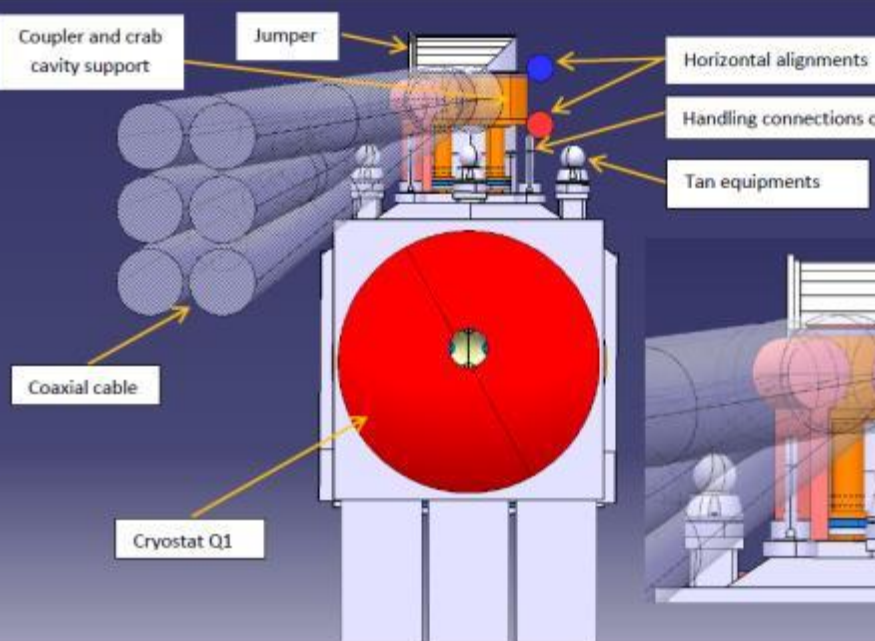

Vertical alignment *from Q1 to Q5*

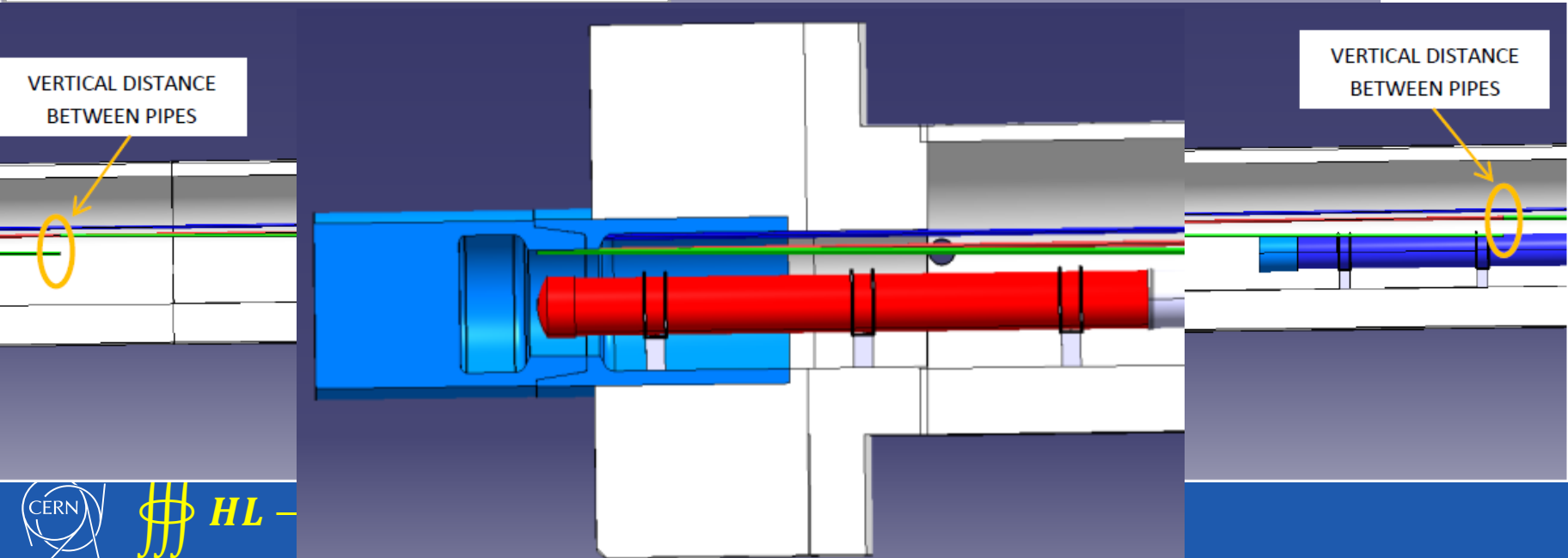
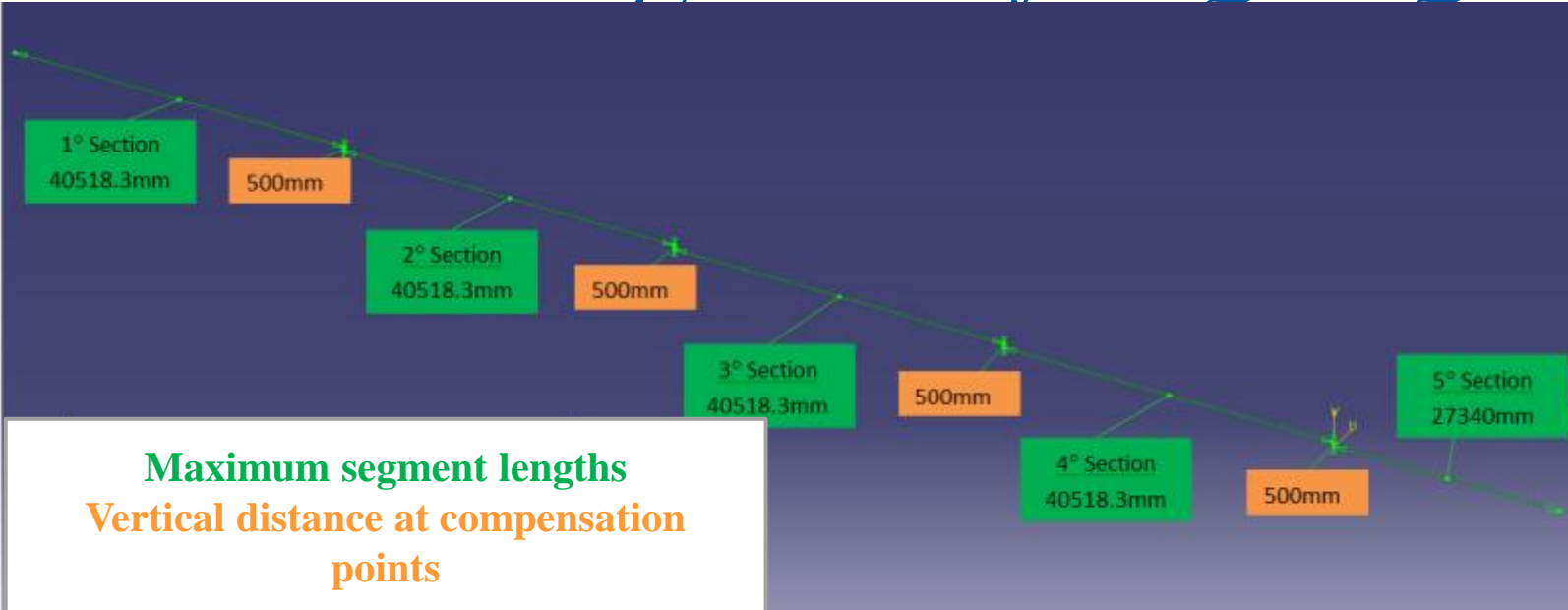

Alignment Service Cavern UPS

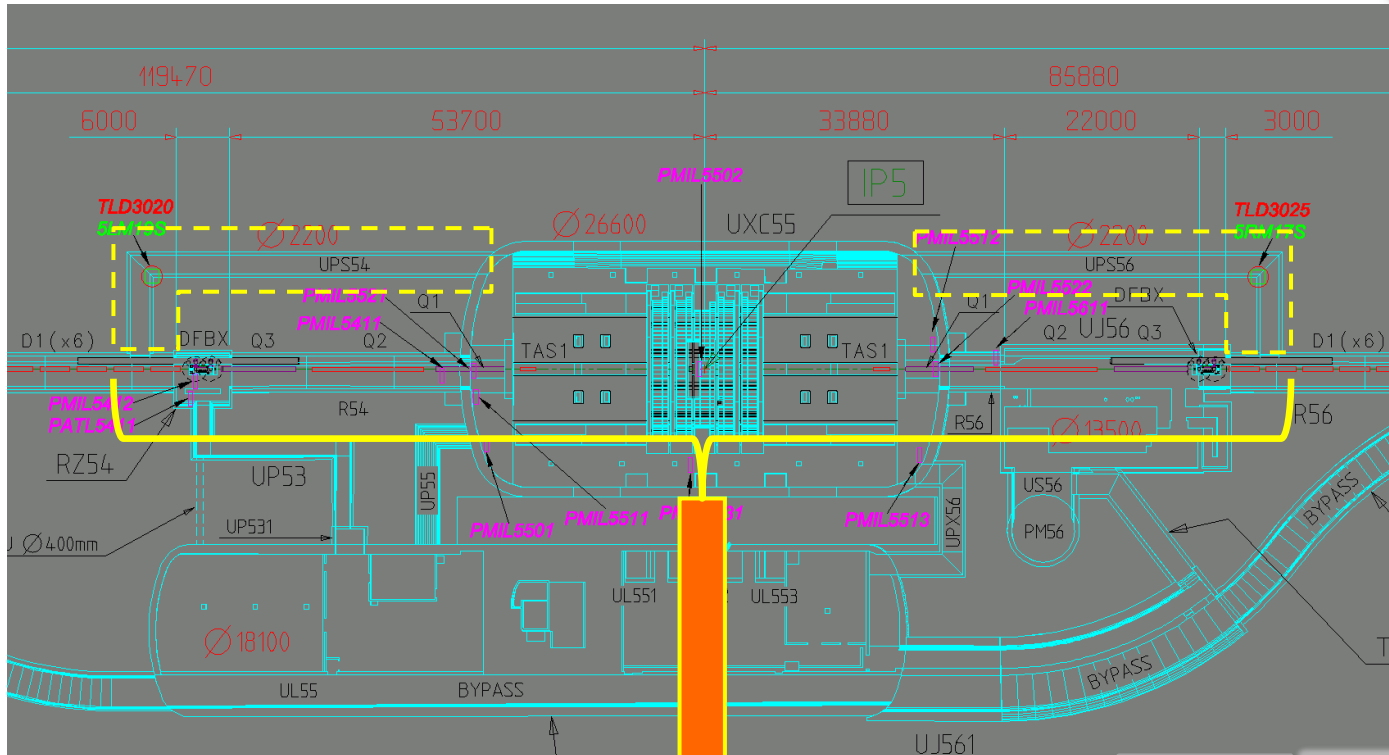

Measured value in 2102 run

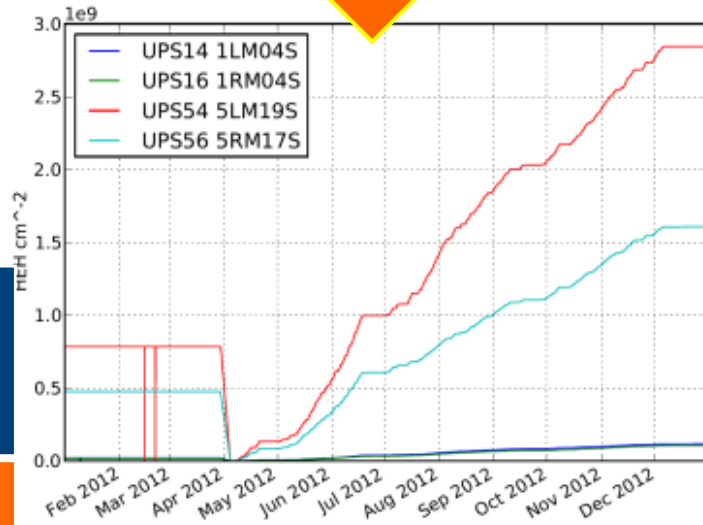

3 10¹⁰ HEH

1.8 10¹⁰ HEH

1 10⁹ HEH

Electronics tested life duration 500 Gy. Very probable issue with TID, better location in UPS to be identified

Scaling factor approx. with luminosity

12

HL-LHC

IP 7

HORIZONTAL SC LINKS

*SEE PRESENTATION J. P. CORSO-S. WEISZ WP 6
WEDNESDAY AFTERNOON*

IR where

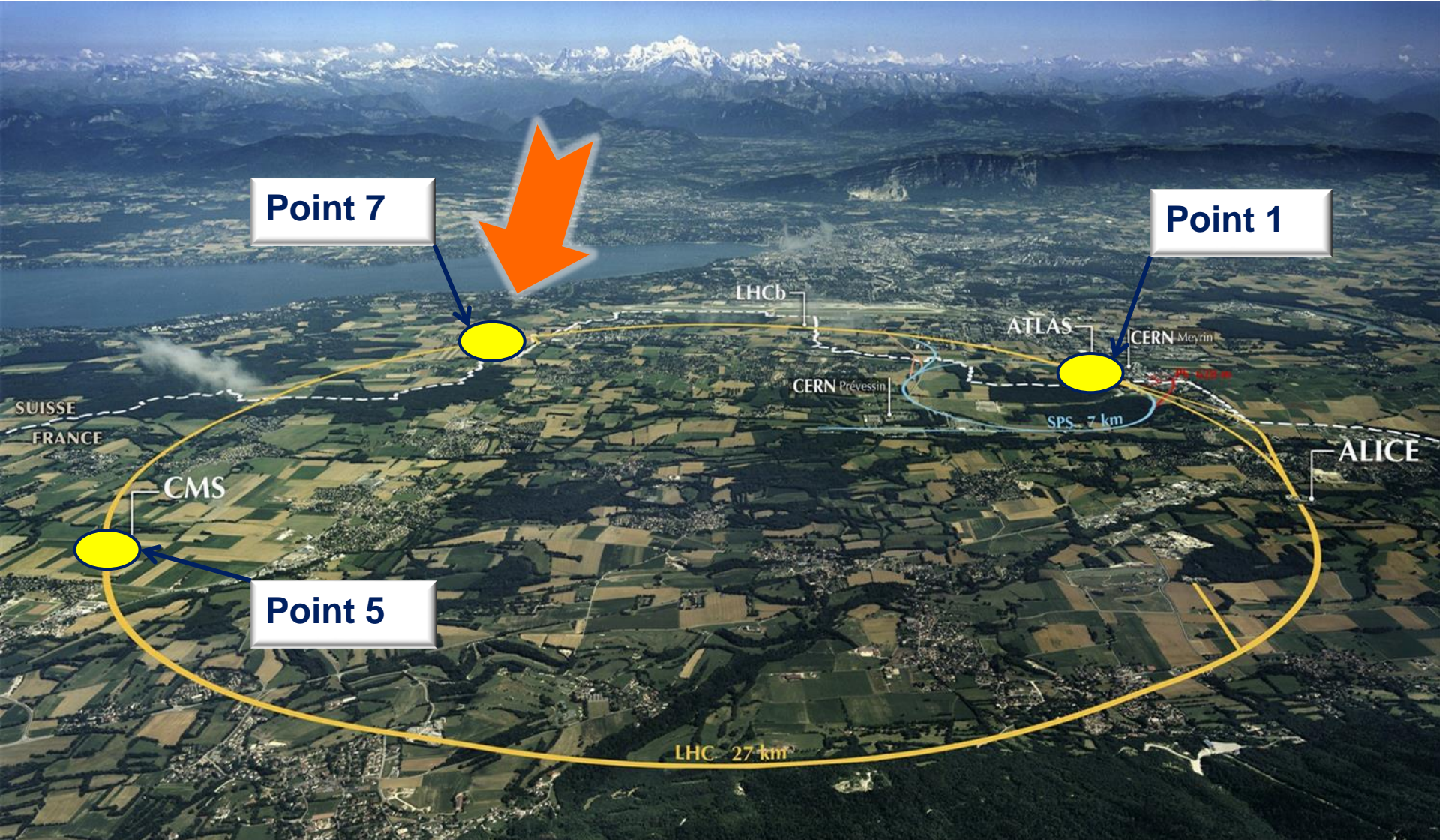

Overview of the Point 7

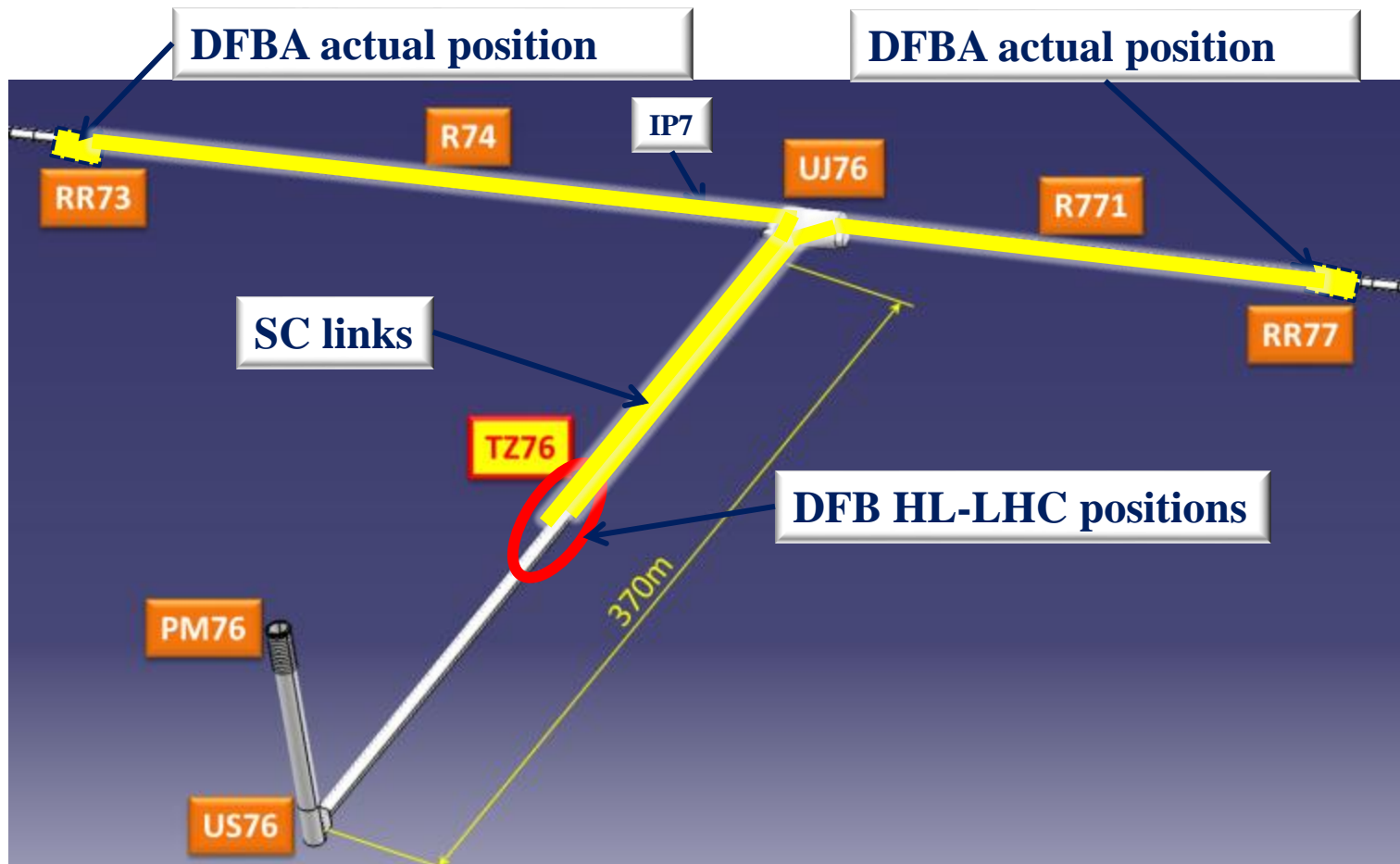

Overview of the Point 7

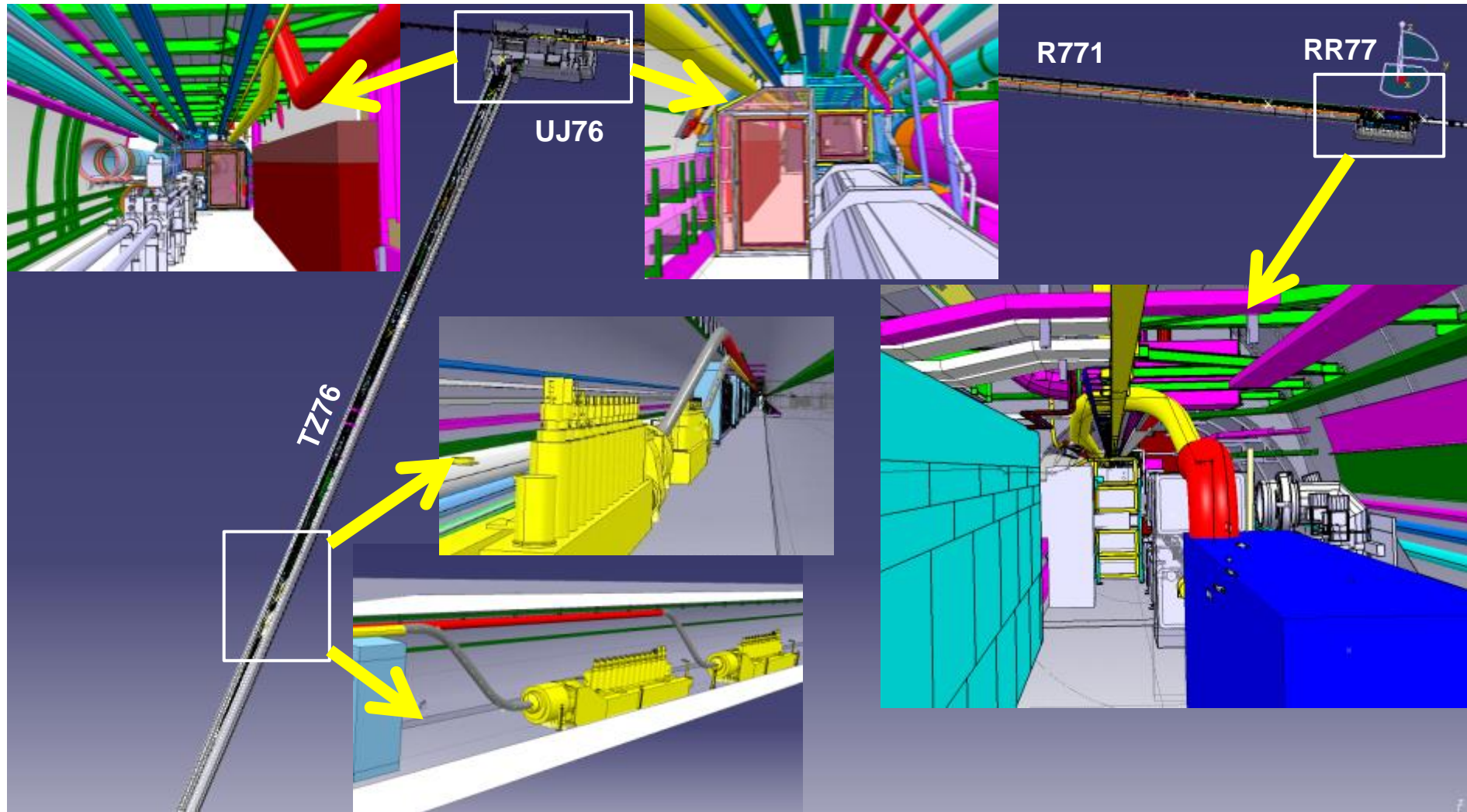

Routing Options – UJ76

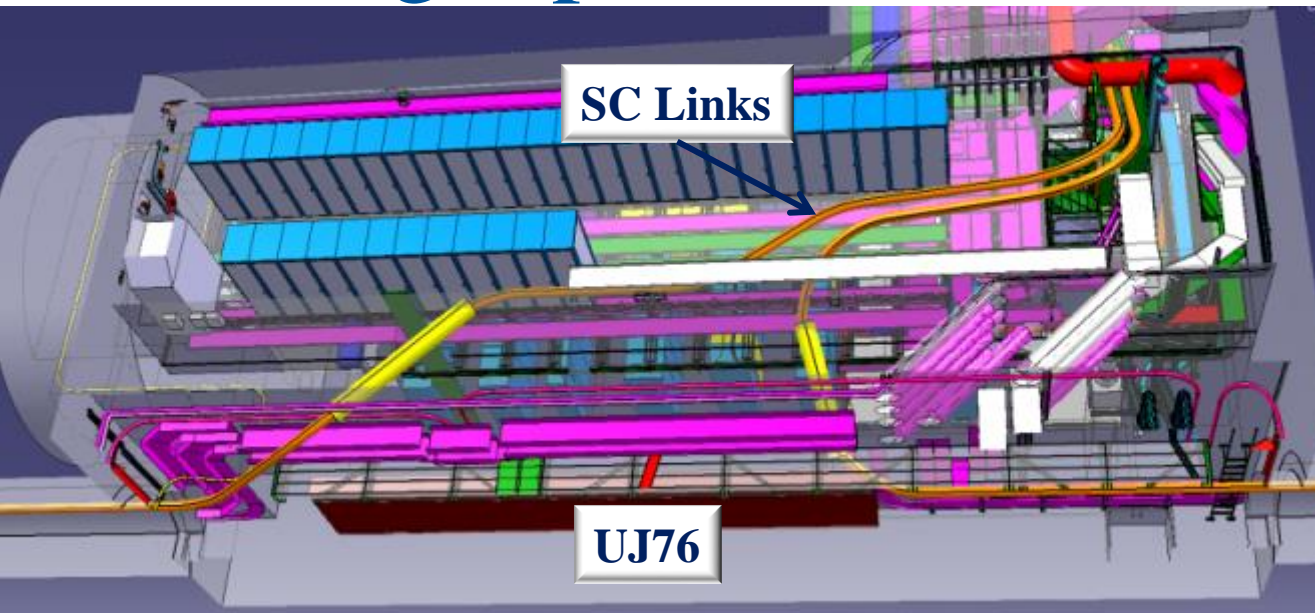

Option 1
2 ducts 3m
Quite complex
path

Option 2
2 ducts 20m;
2 ducts 3m,
less bends in the
cryostat

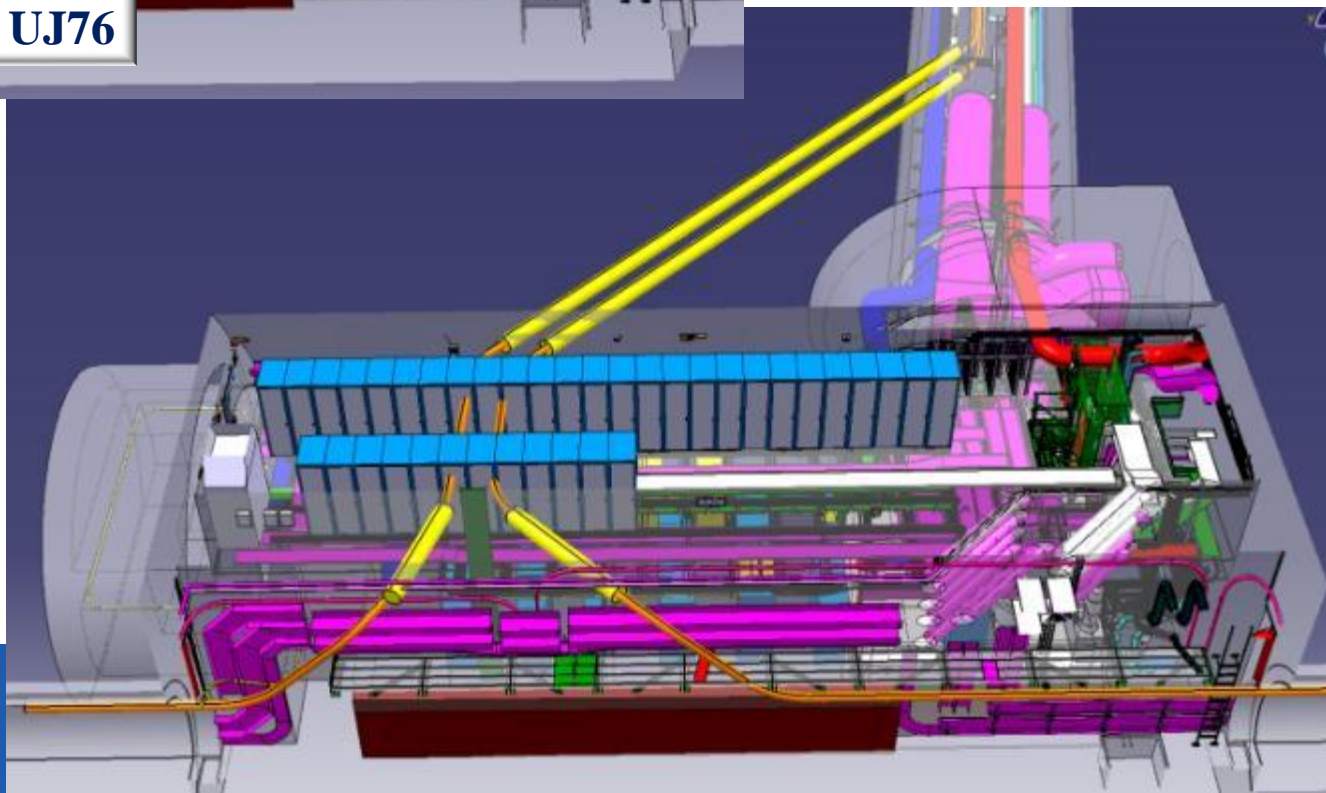

COLLIMATION

*1ST VIEW OF THE COLLIMATION SYSTEM
REINFORCED BY THE NEW MASKS, NO
OPTIMIZATION PERFORMED YET*

1st view of the collimation system reinforced with masks (under analysis)

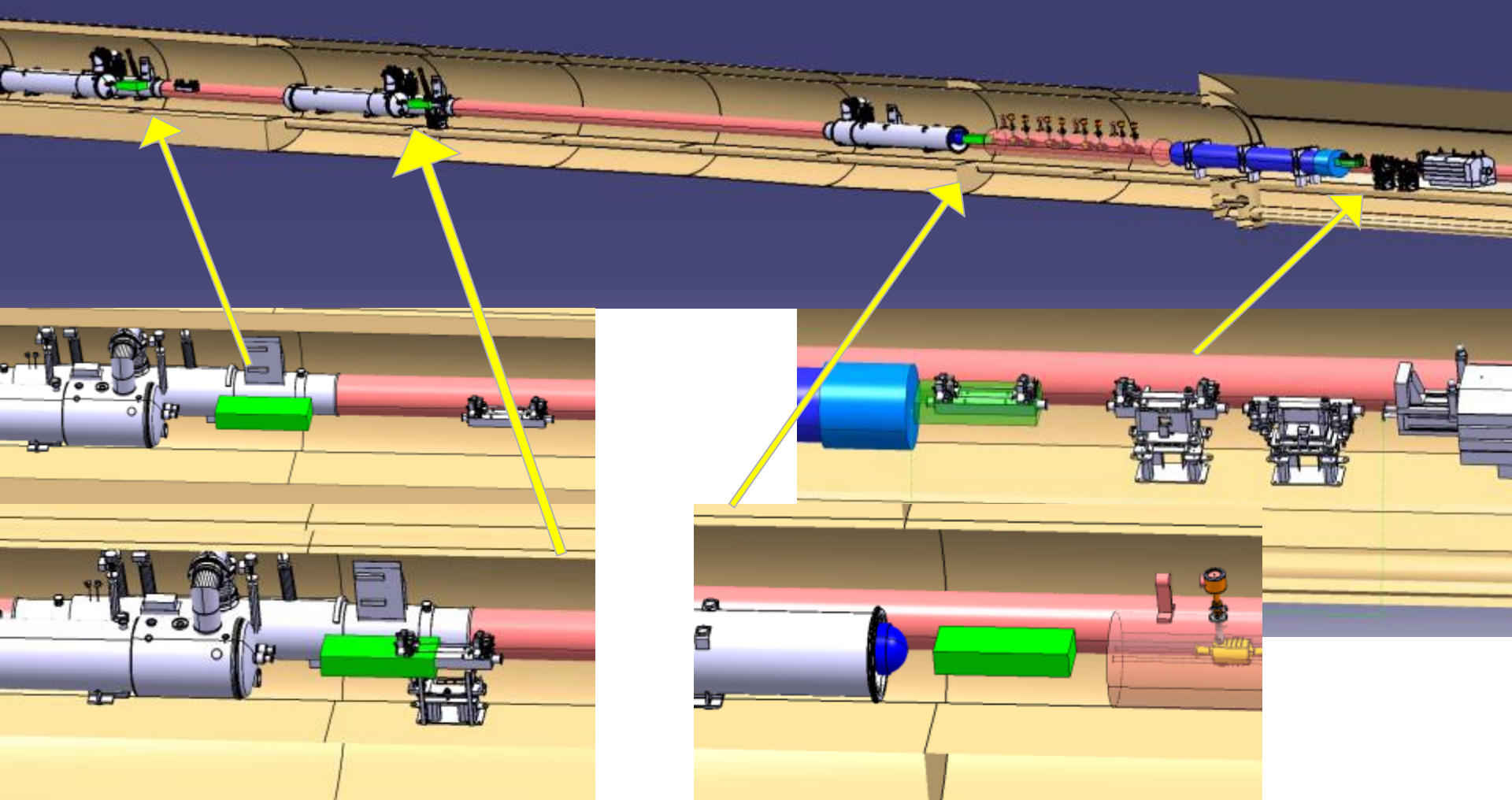

NEXT STEPS AND CONCLUSIONS

HL-LHC Layout and integration I



- An HL-LHC dedicated integration team is taking shape and available resources will increase from March 2014
- 1st integration studies have been carried out for the magnet system, crab cavities, alignment and SC link
- Next steps I
 - Magnet system
 - Upgrade the 3D model to the baseline cryostat diameter / shape
 - Following steps depends on the cryogenic routing, bus bar routing
 - We need to have 1st estimation of the cryogenic underground installation
 - Crab cavity:
 - Complete with the crab cavity team the revision of the space requirements, presently due the space constraints, and the R2E issue the installation of the RR electronics in the RR look to be challenge
 - Alignment
 - Needs identified, but problems in term of access. Need to look at options in order to improve accessibility-maintenability and limit radiation dose to personnel

HL-LHC Layout and integration II

Next Steps II

- SC link:
 - Progress with the detail design in correlation with the cryostat installation procedures
- Collimation
 - Analyse in details requirement vs. practical feasibility and space available taking into account space for insulation vacuum and beam vacuum sectorization
- Point 4: complete the revision of the available space for e-lenses, 800 MHz, 200 MHz, ...
- Mandatory to start working with approved system/equipment functional specification
- Release 1st series of 2D lay out drawings to have a reference baseline setting up all the requirement links with the database
- We need to start working extremely urgently on the cryogenics system at point 1,4 and 5 that could have major impact on the underground space
- “Given the importance of radiation levels in several locations, a follow-up during 2015/2016 operation should be envisaged for the radiation monitoring (putting more monitors in critical areas, performing a respective analysis, scaling evaluation, etc.)”
(M. Brugger)

BACK UP SLIDES

D2 to Q4. Point 5L

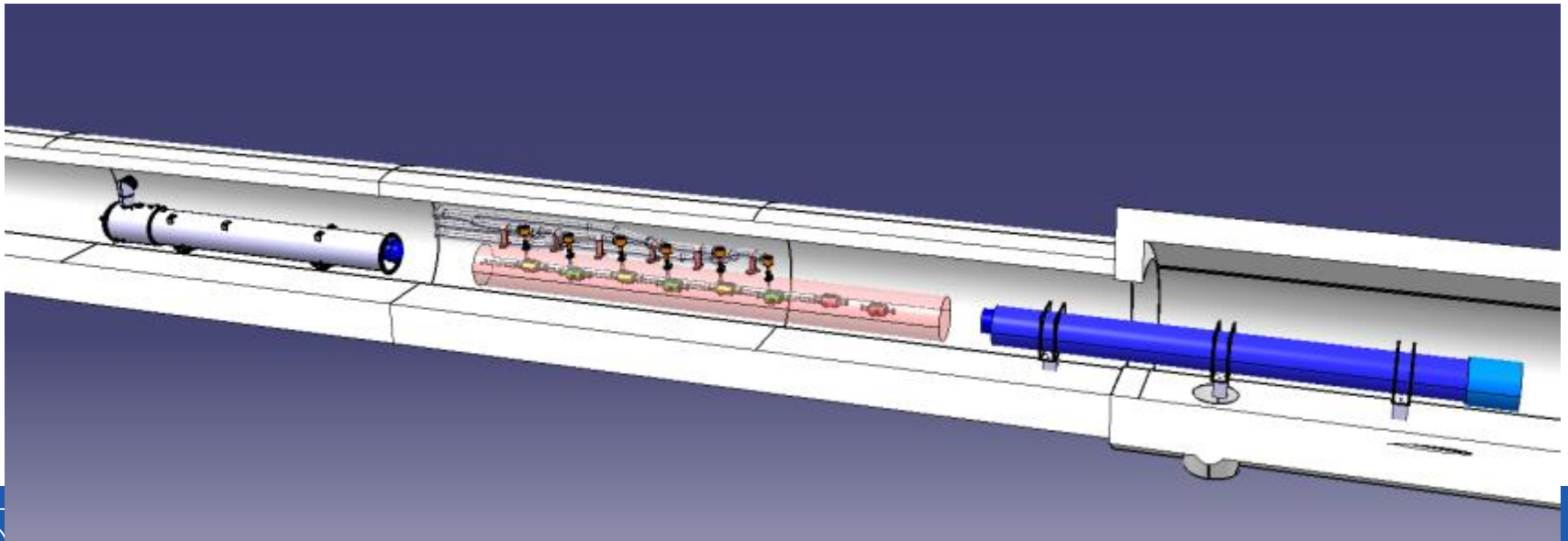
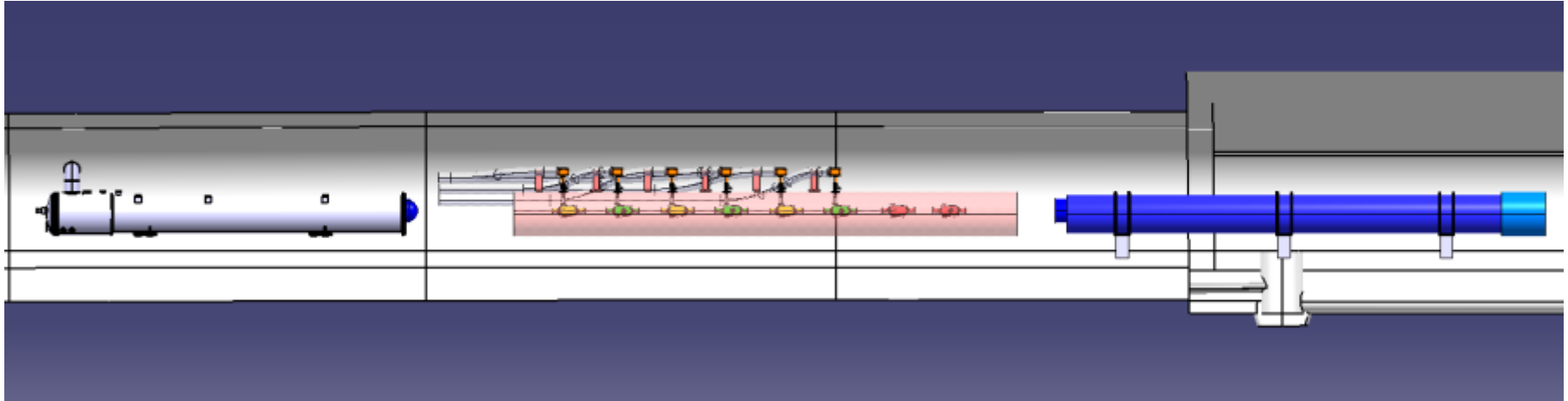

Q1 to Q4 (General view). Point5L

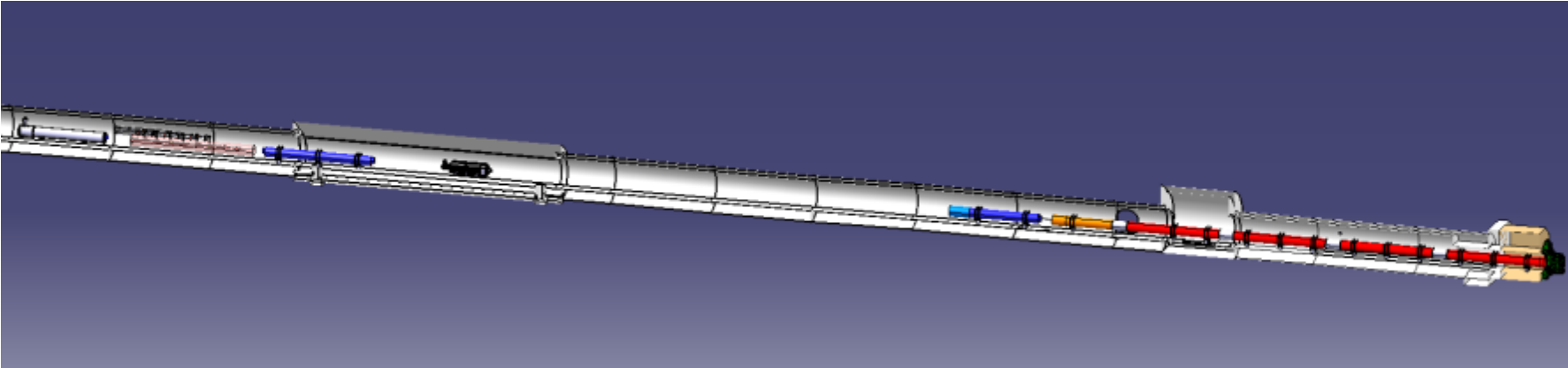
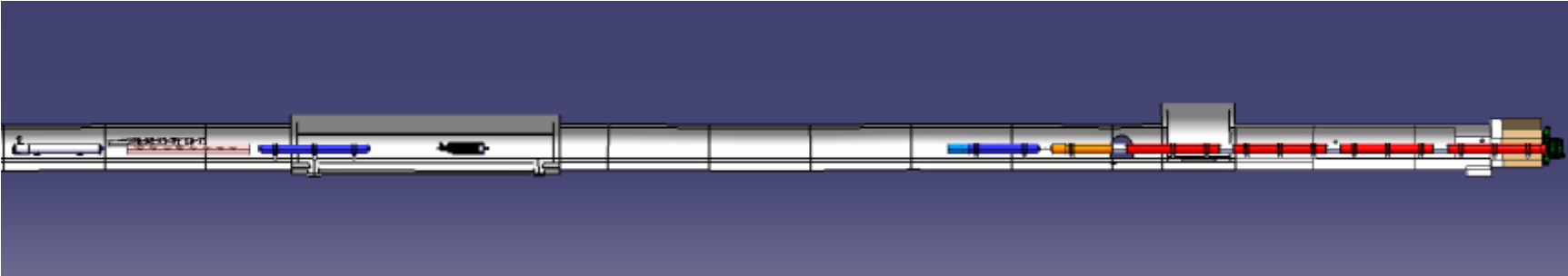

Q1 to Q4 (Magnetics Length). Point 5L

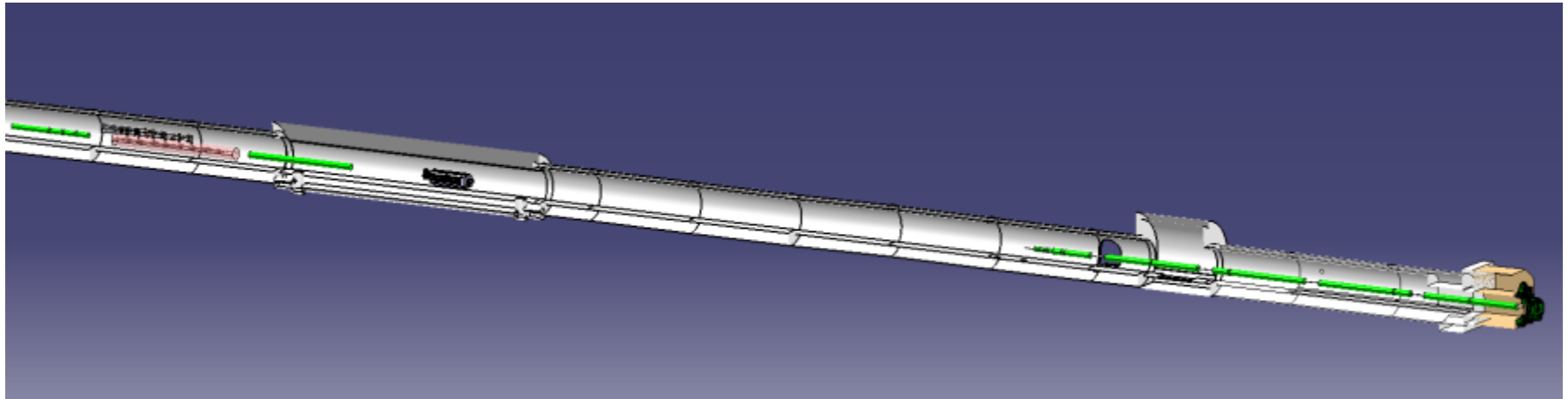
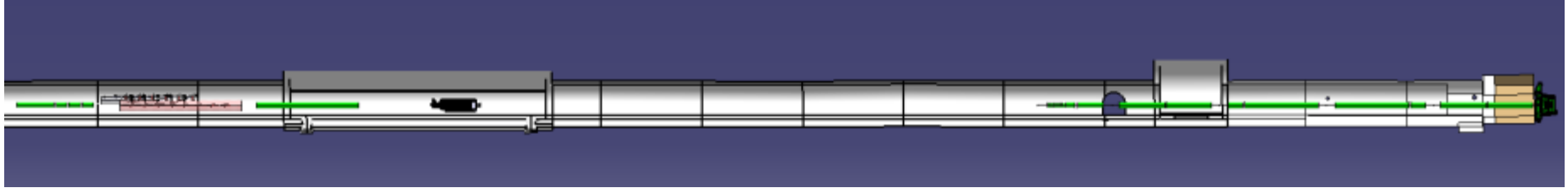

Q1 to D1 (Magnetics Length) Point5L

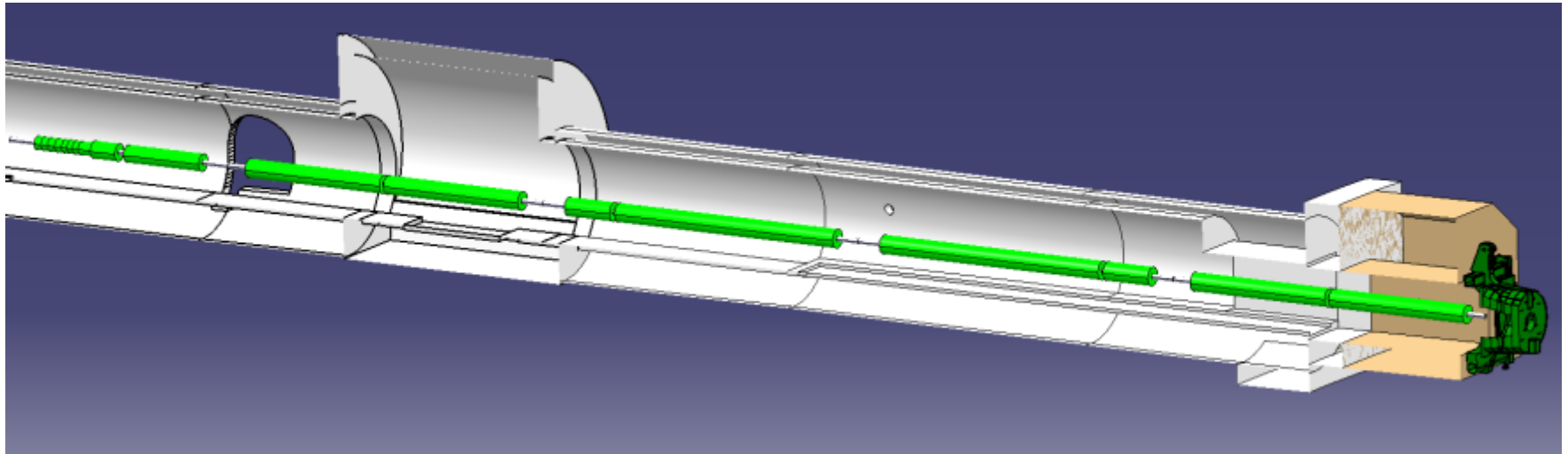
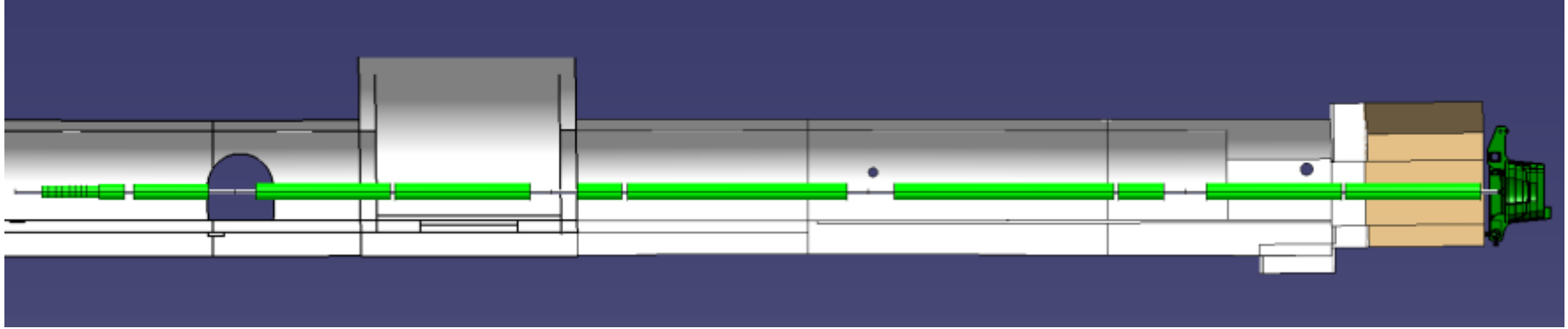

Q1 to D1 (Cold Mass. Point5L)

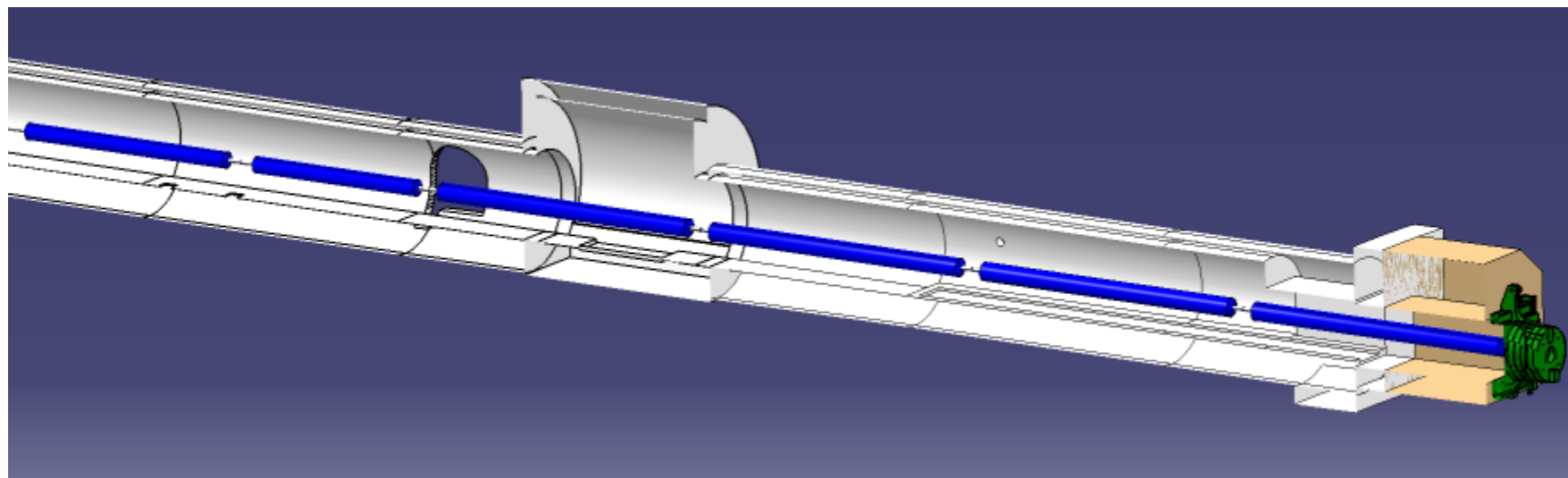
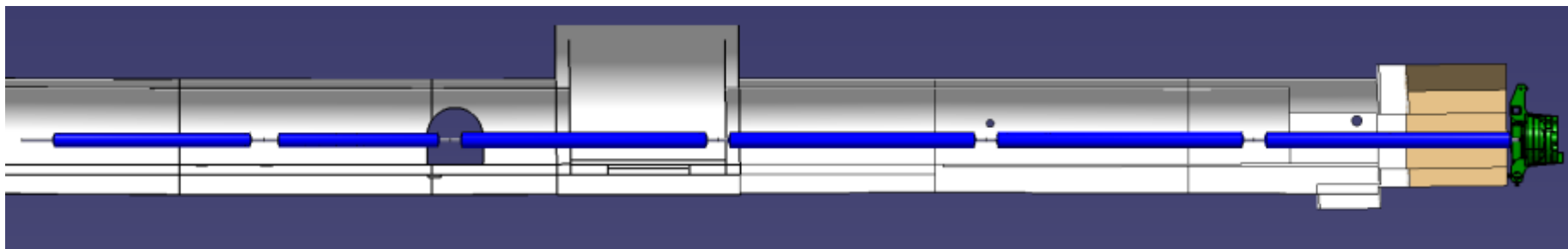

Q1 to D1 (General View). Point5L

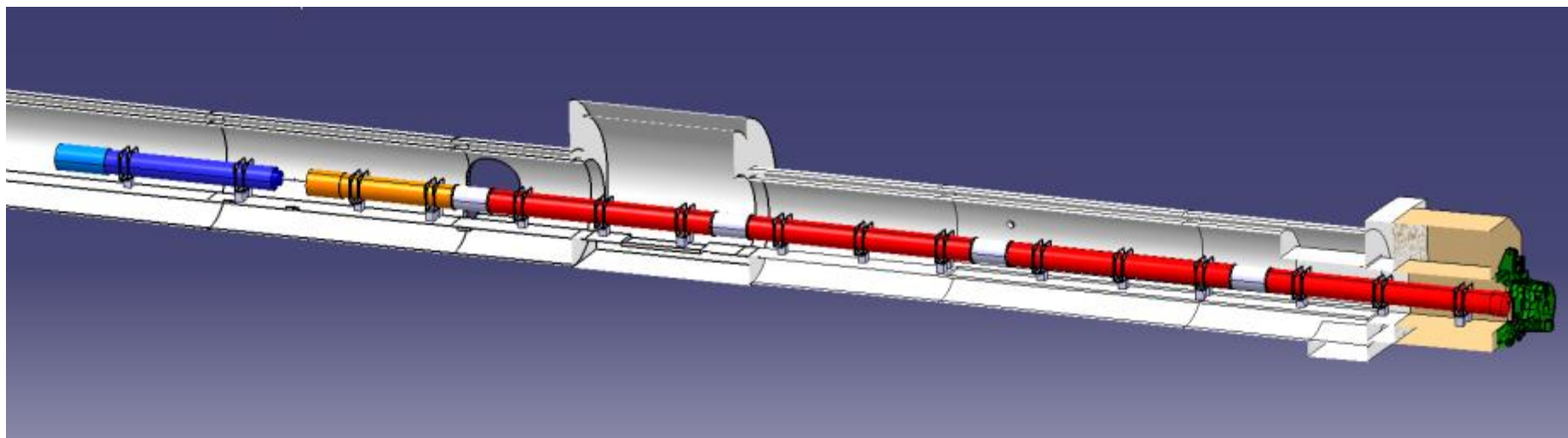
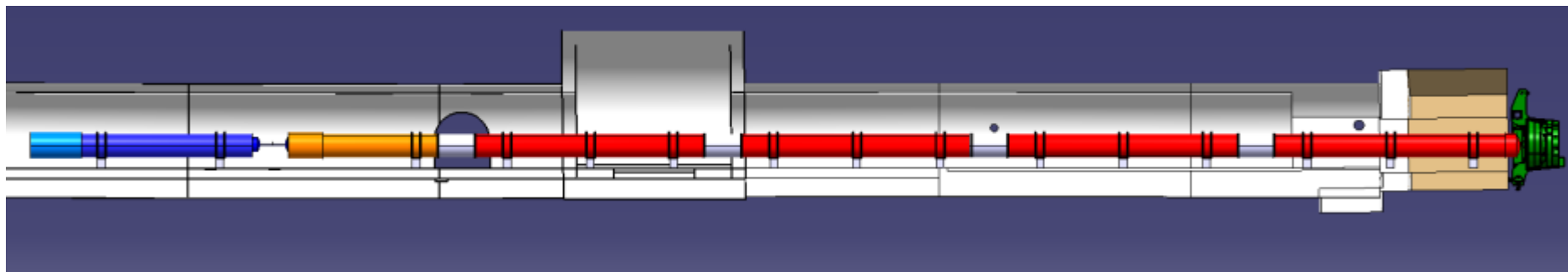

Q1 to Q2 (General view). Point 5L

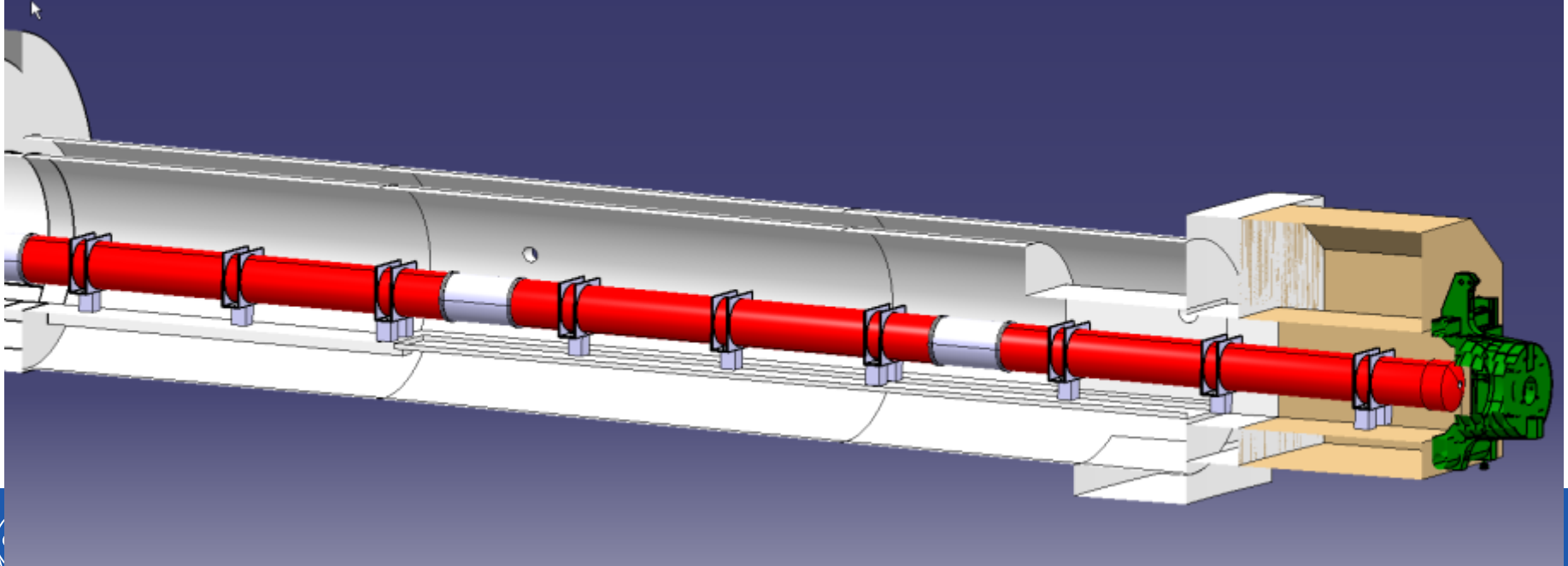
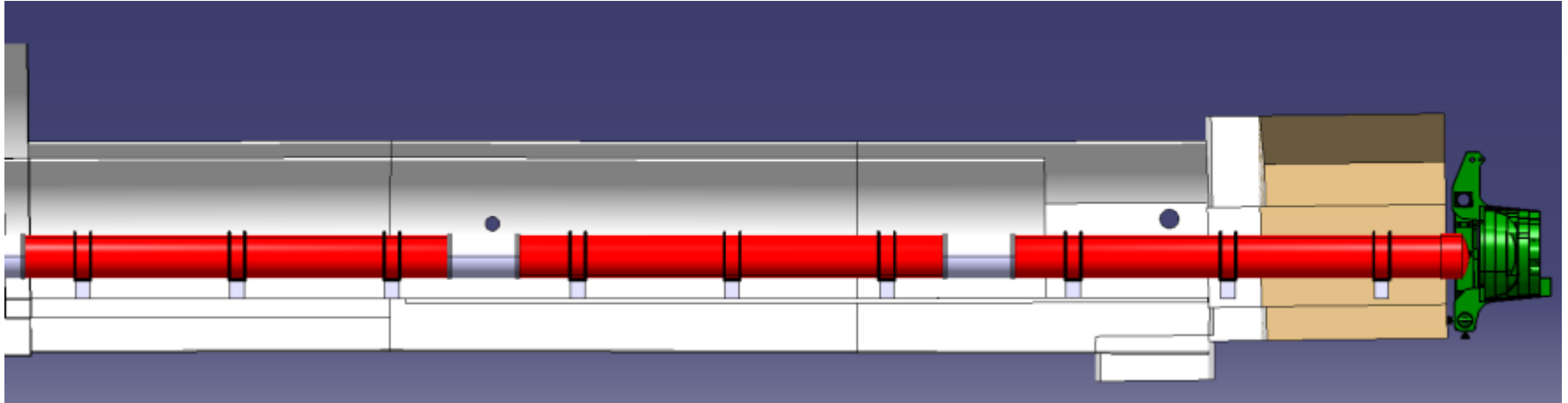

Q1 to Q2 (General view). Point 1L

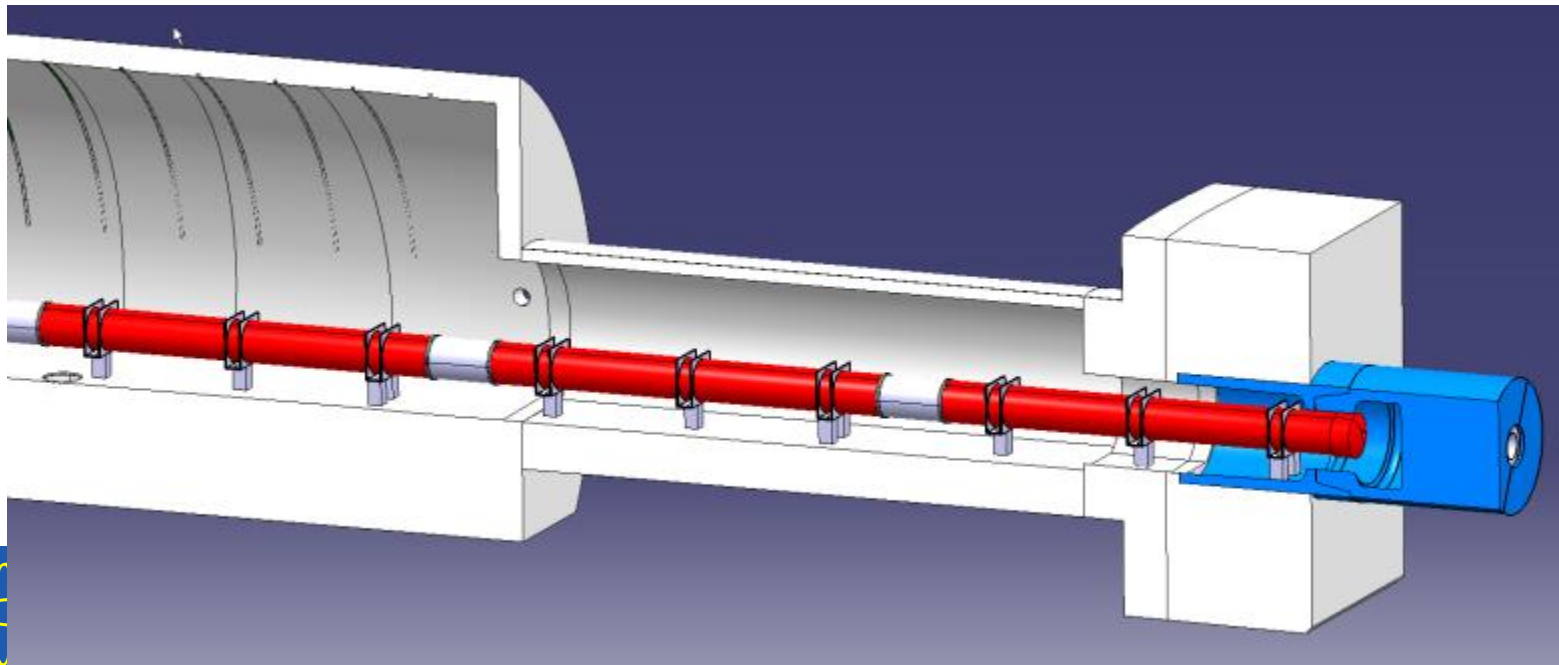
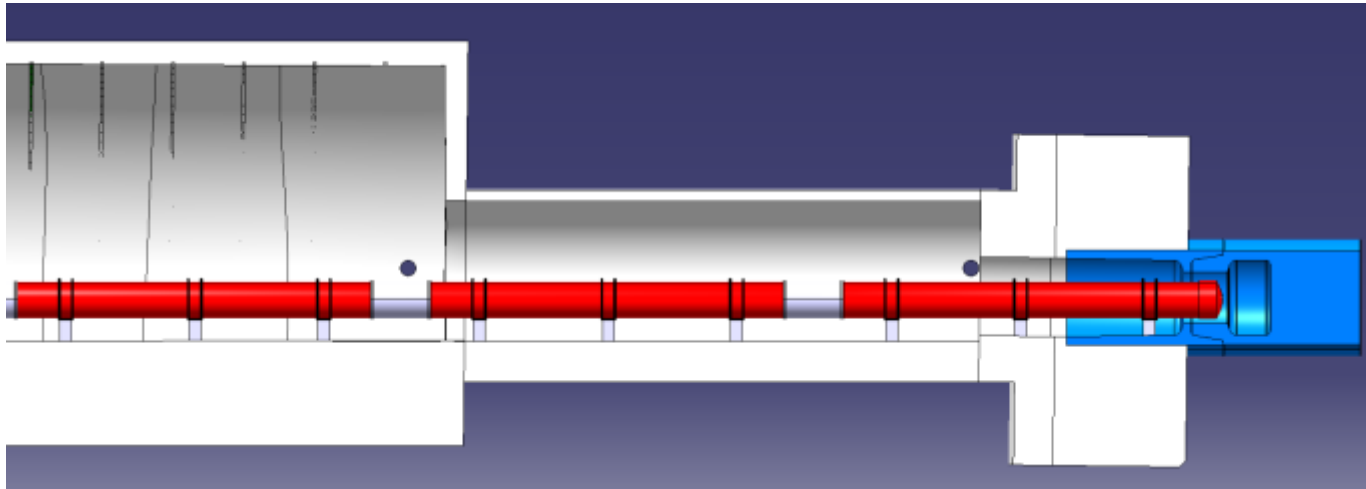

Crab Cavities Integration Point 1 & 5 – LS3

- ✓ UL14-US15-UL16
- ✓ USC55

Global View Point 1

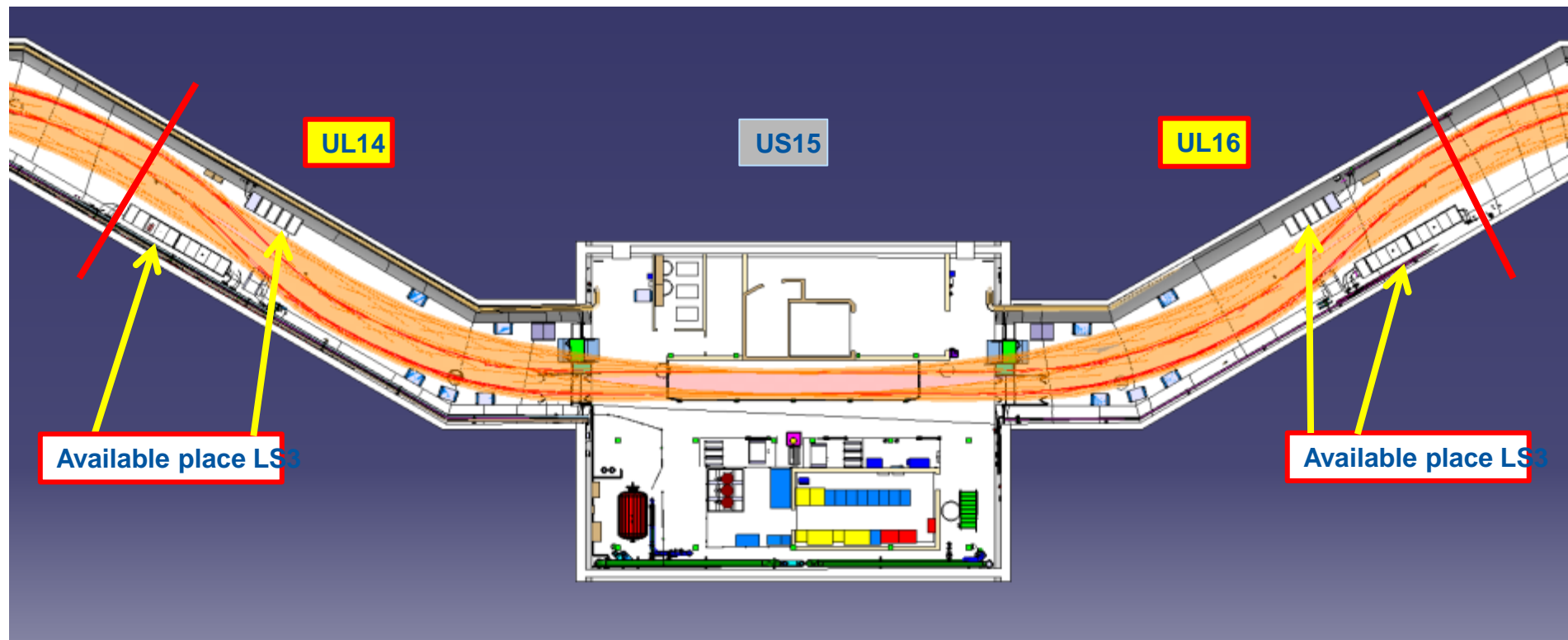

Zoom on UL16

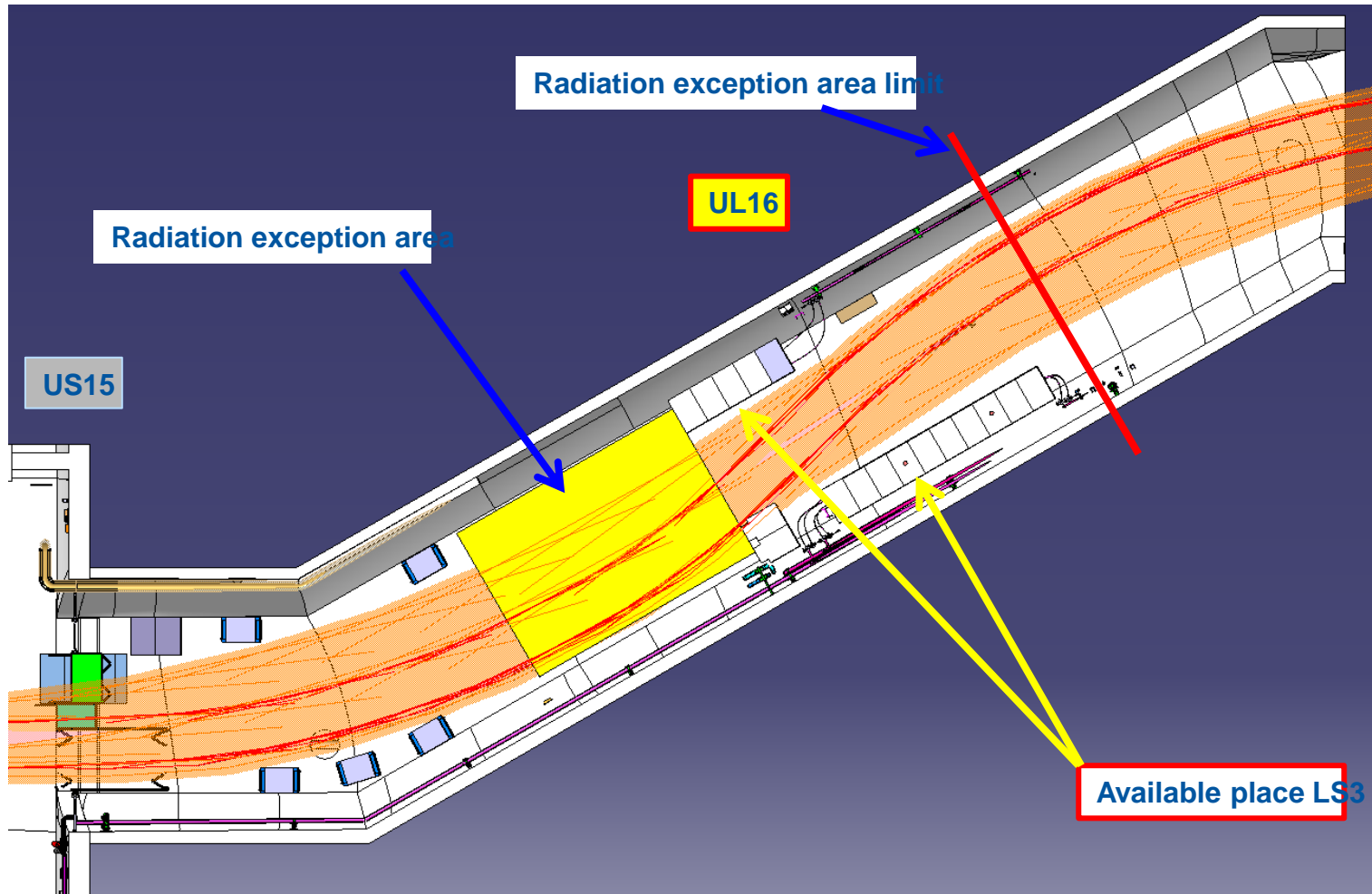

Asymmetry Issue

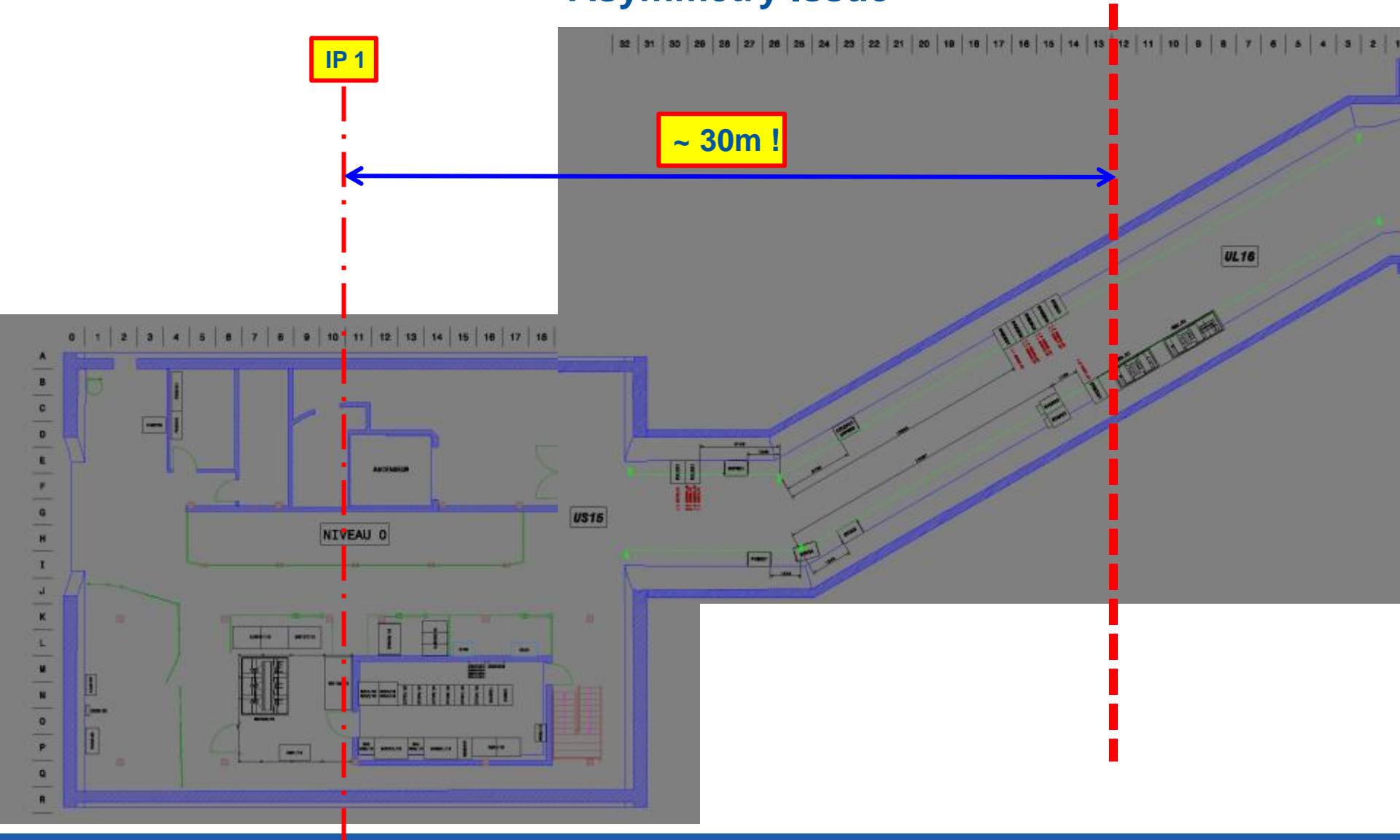

US15 – 3 reserve racks on 3rd level...by now

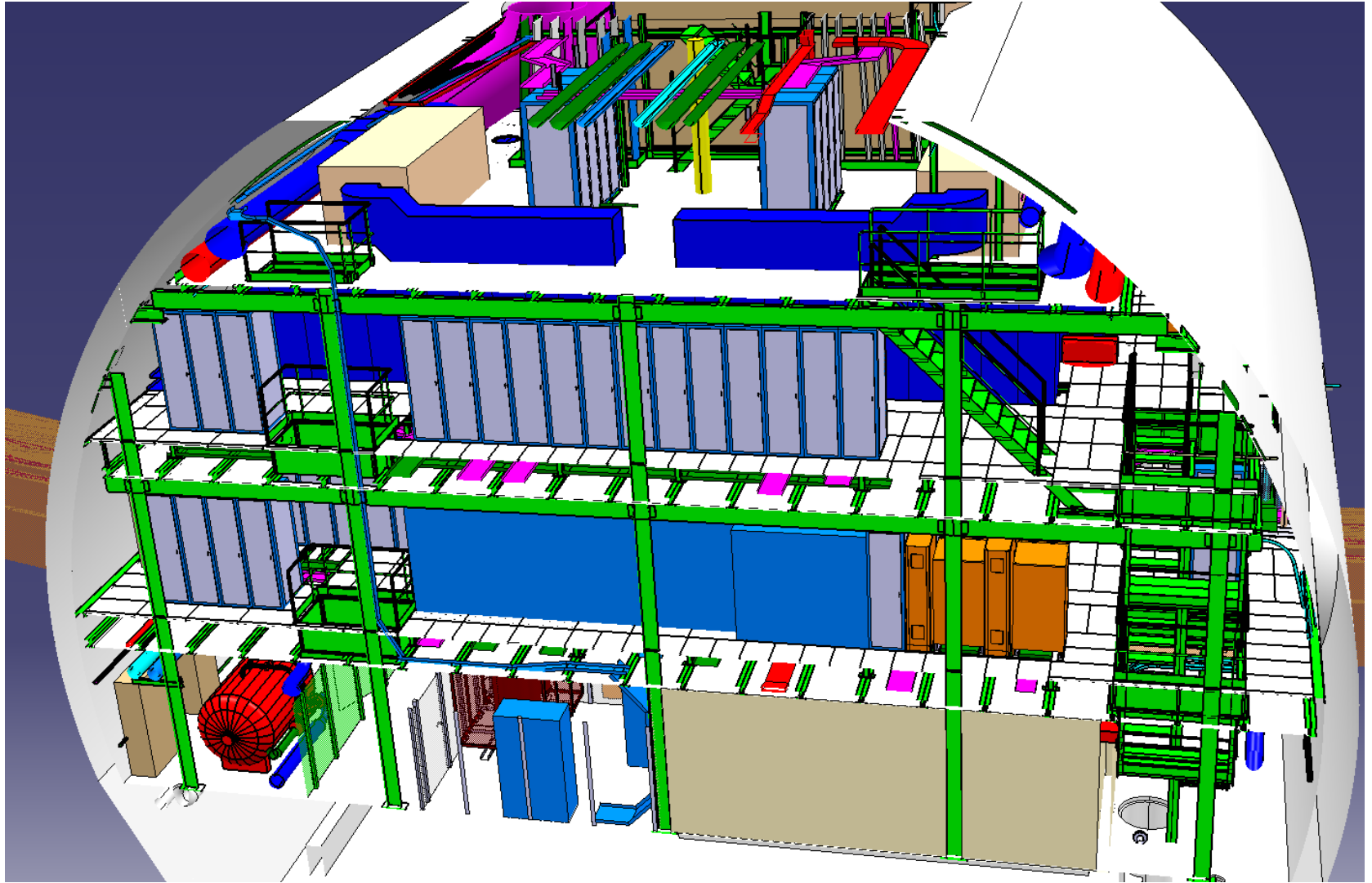

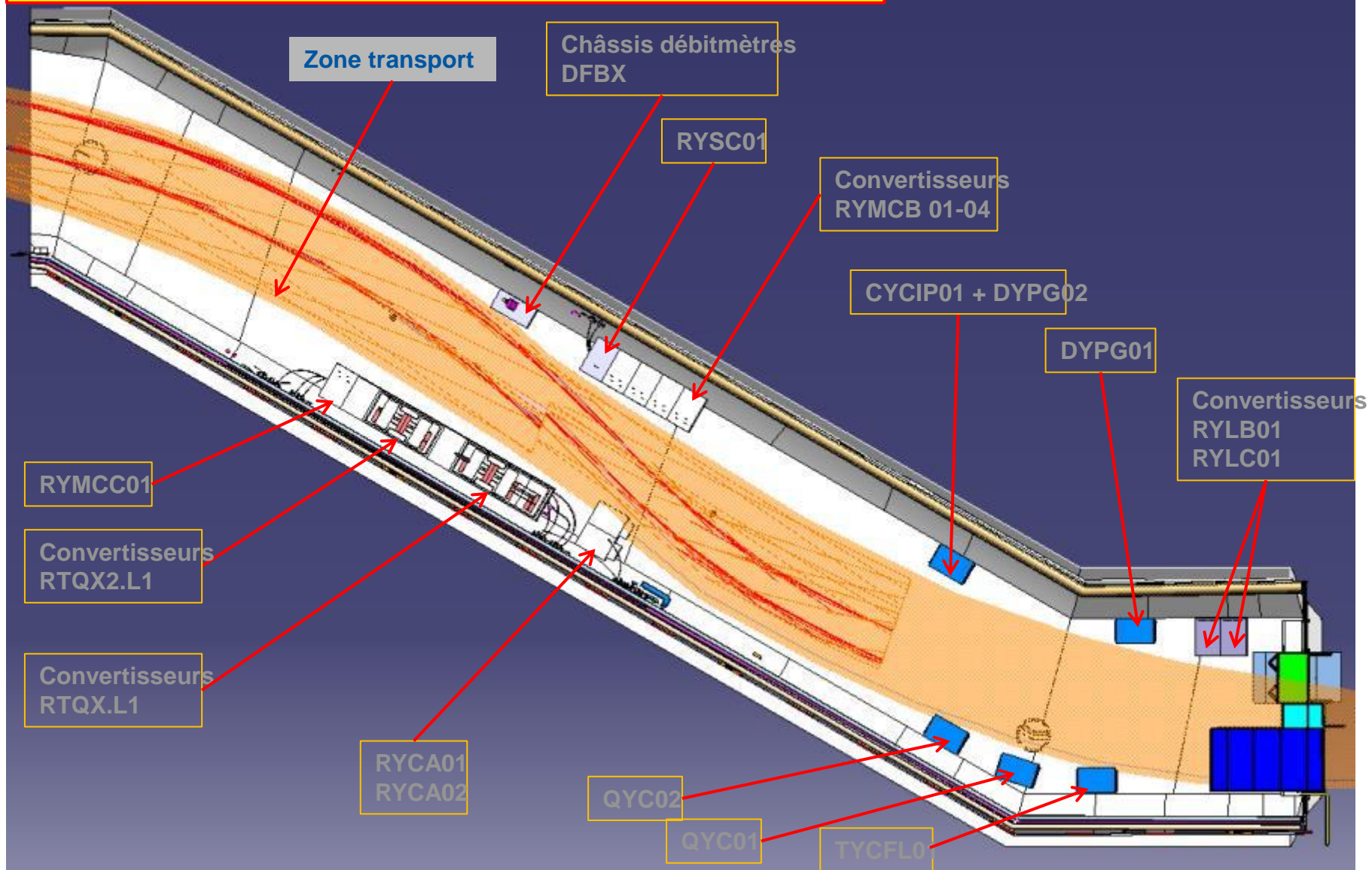

UL16 – 2014/03 – Relocalisation Racks & Convertisseurs

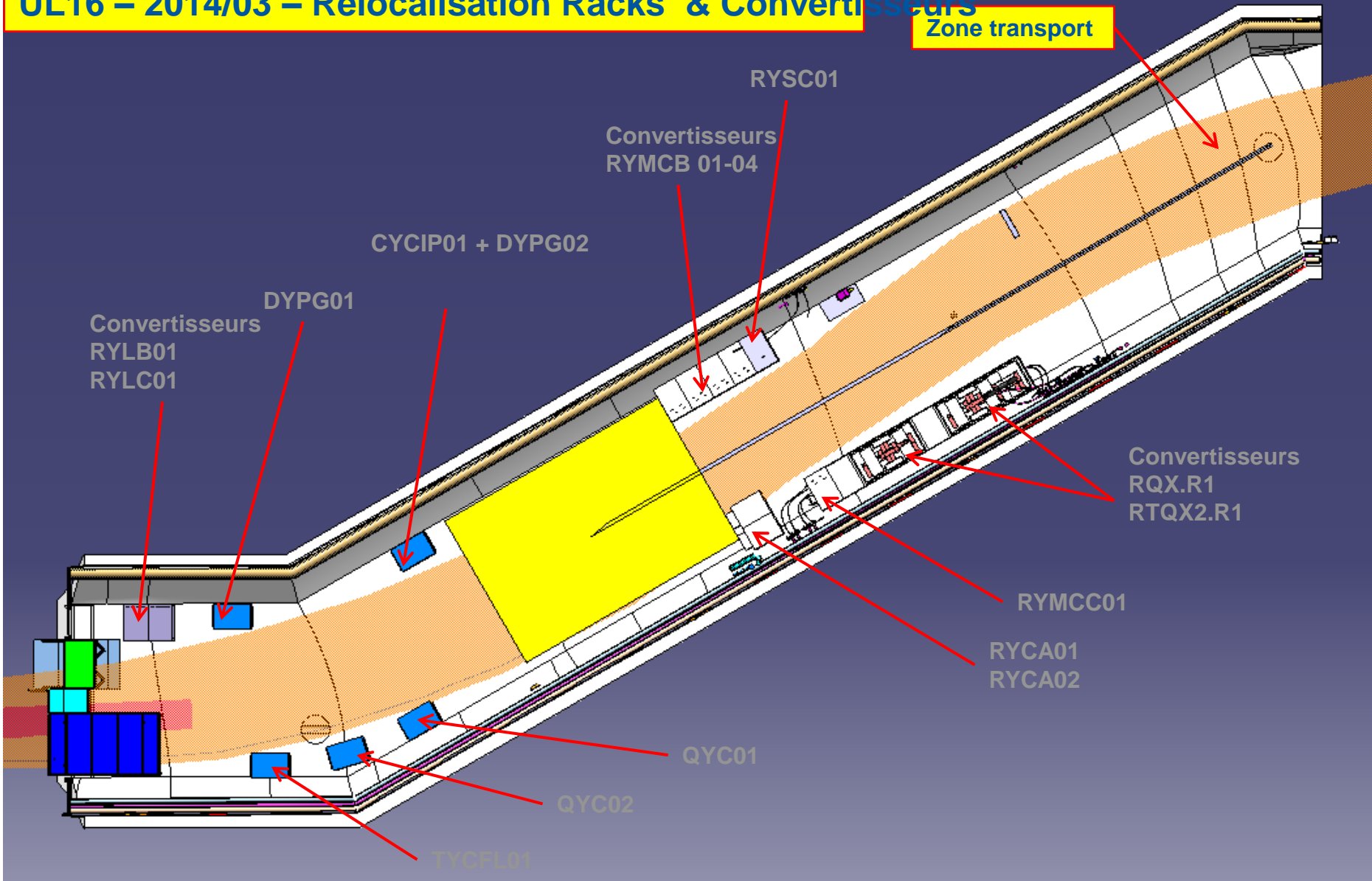

Global View Point 5 around IP

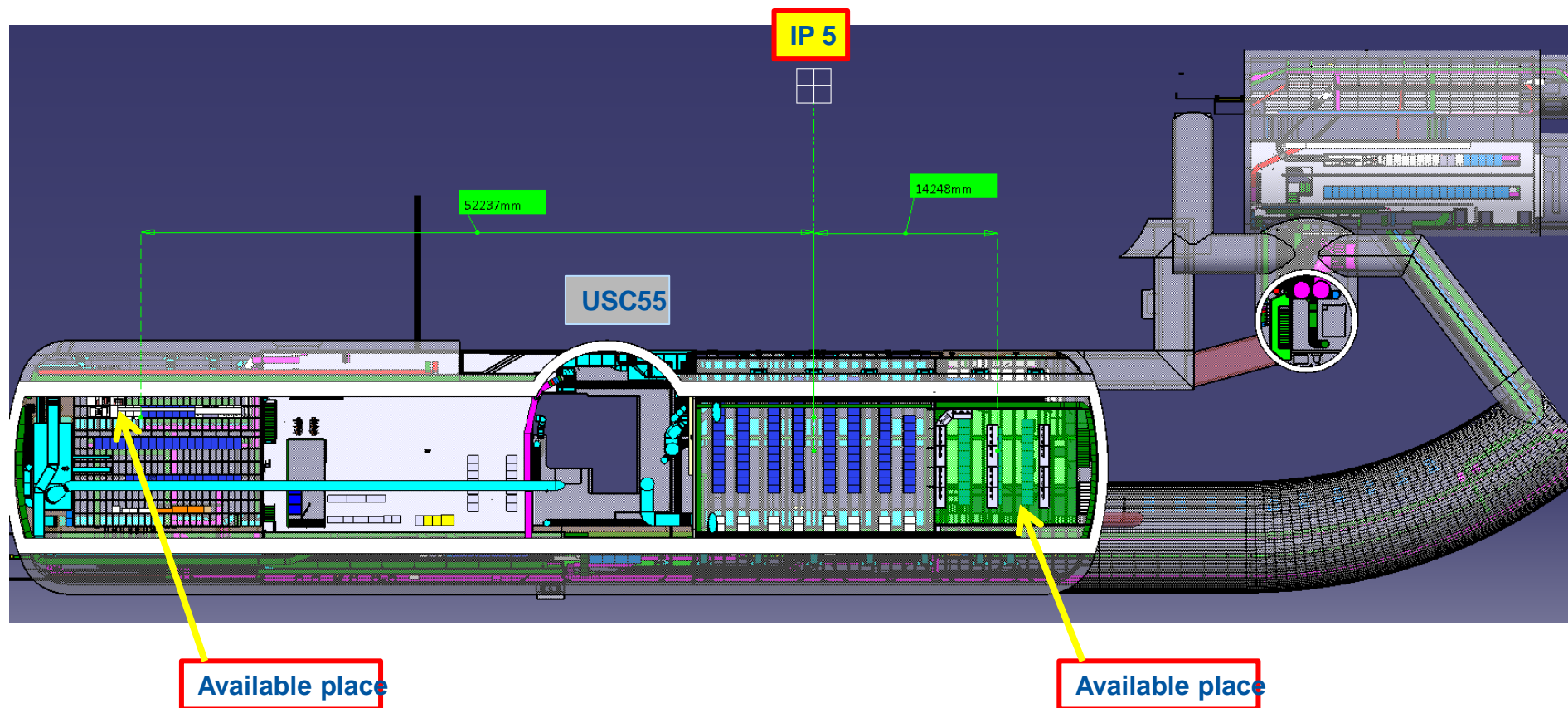

USC55 – 3524-U2-001 - control room

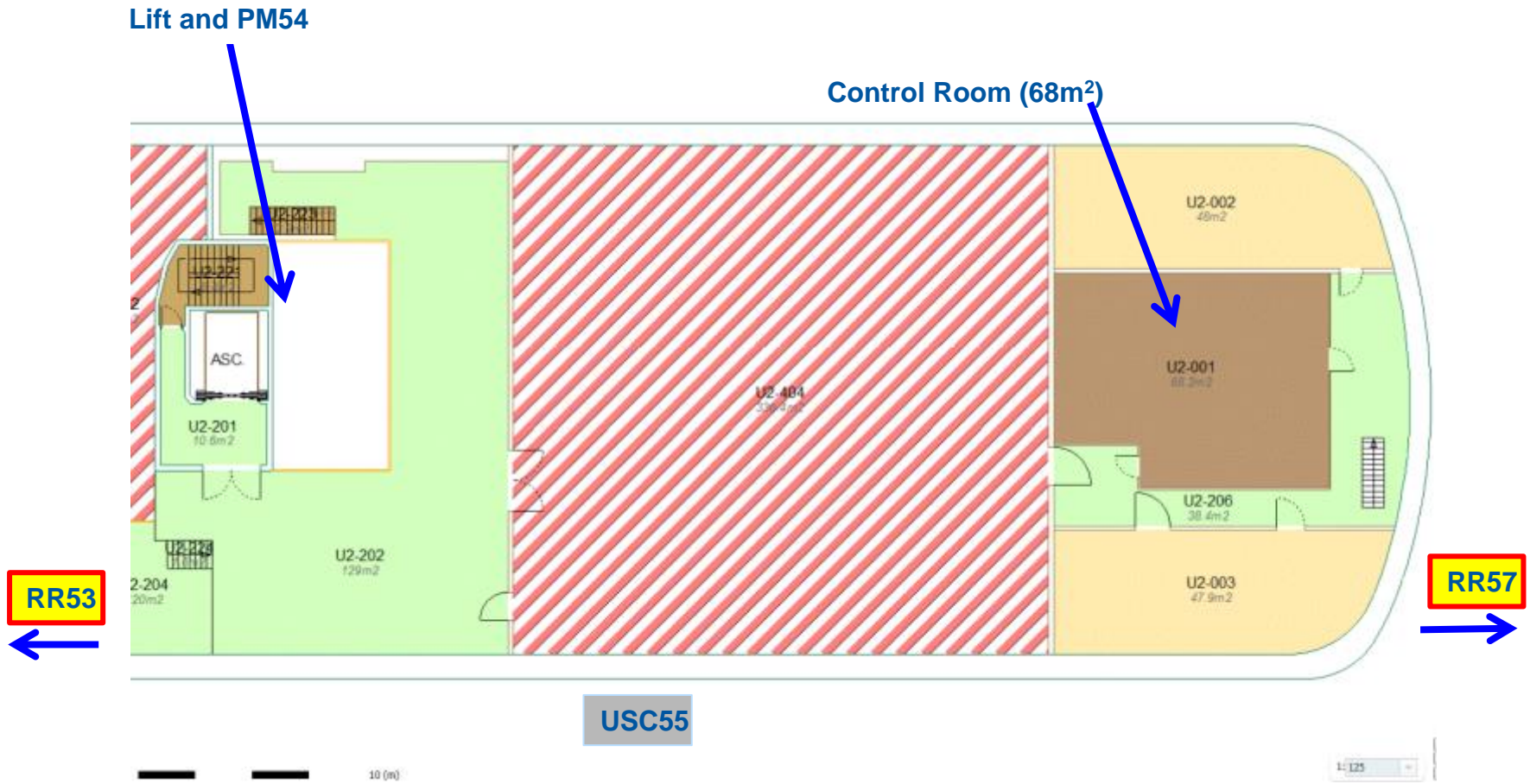

USC55 – 3524-U2-001 - control room

Lift and PM54

Control Room (68m²)

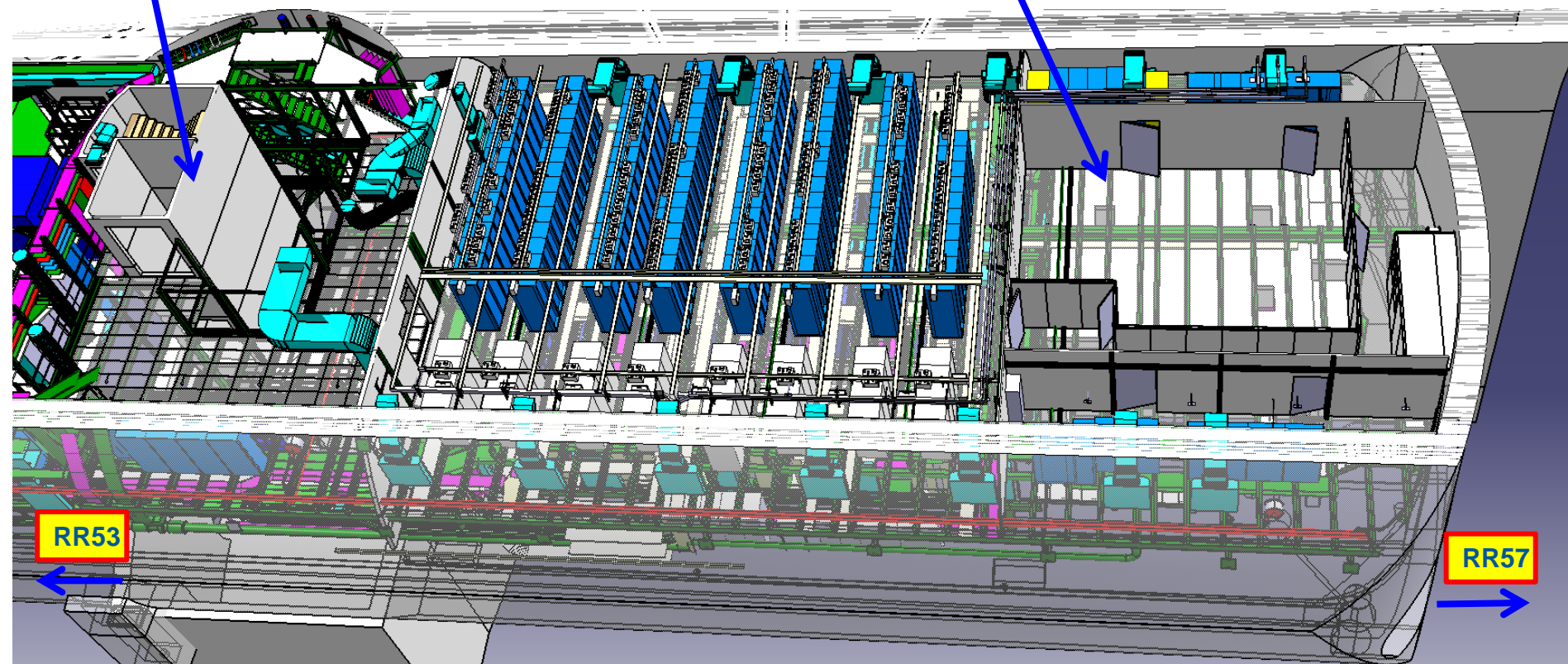

USC55 – 3524-U2-001 - control room

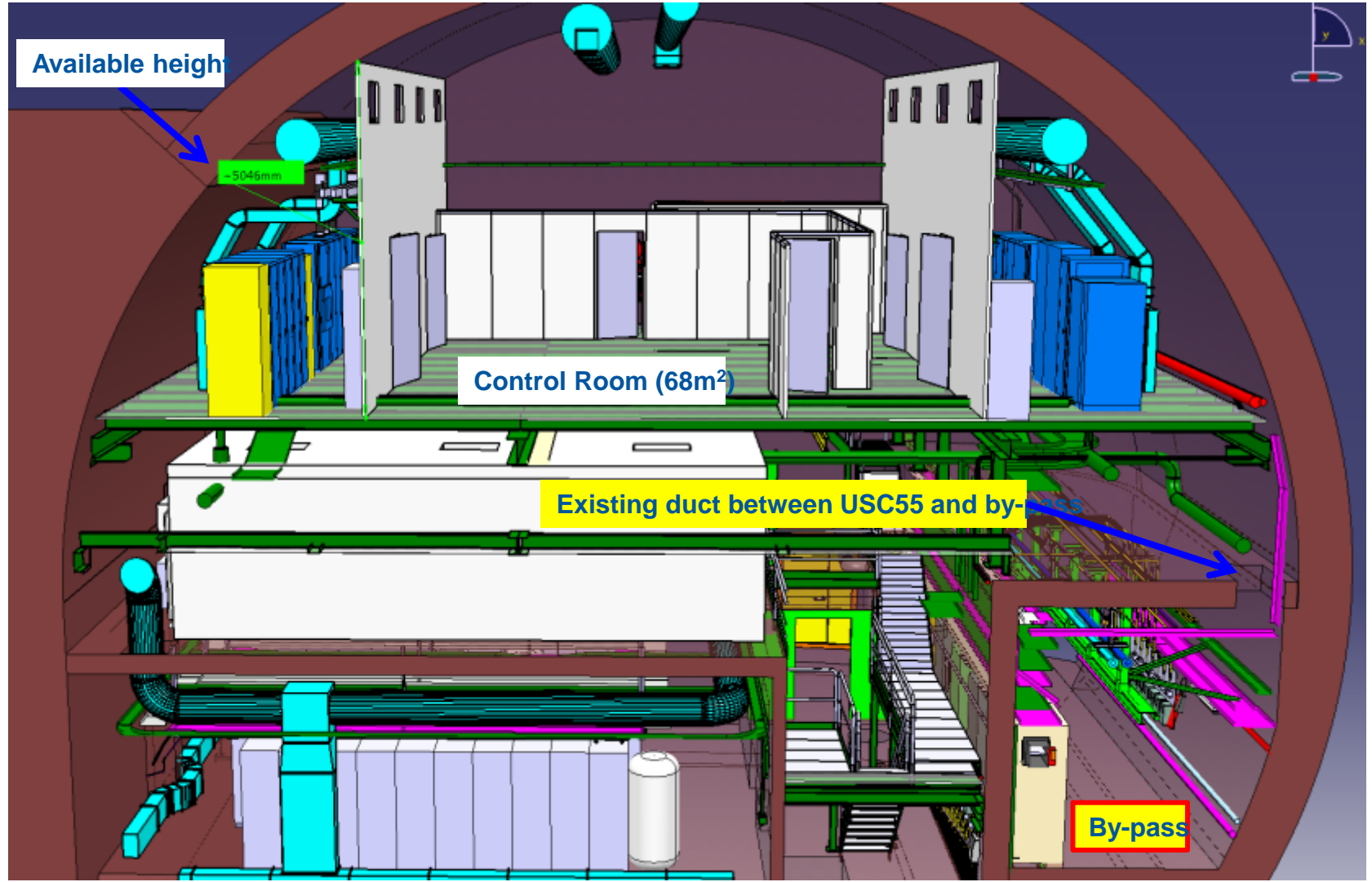

Very last option – “mezzanine”

